

PED Editor User Guide

PED Editor created by Eric Boesch

User Guide by William Laws

User feedback/support → phase2@nist.gov



(L to R): Eric Boesch, Chris Dominguez, William Laws)

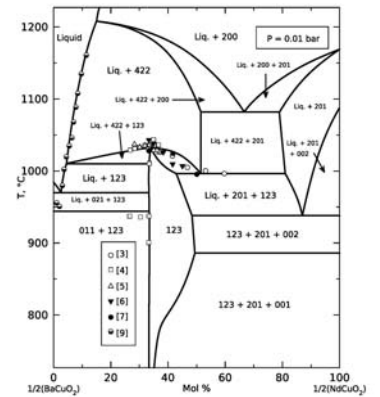
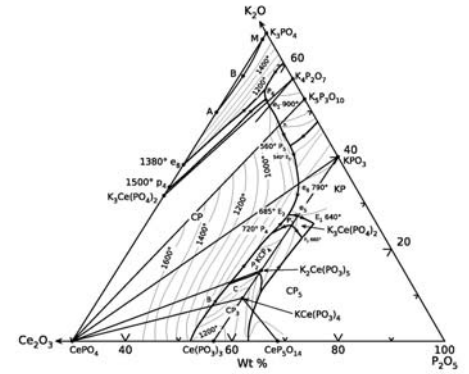

[Quick-Guide: Shortcuts](#) **2**

[Getting Started](#) **4**

Diagram: Scale Setup

- [Binary or Cartesian](#) **6**
- [Ternary](#) **8**
- [Partial Ternary](#) **10**
- [Partial Ternary – Trapezoid](#) **12**
- [Freeform](#) **15**

Digitization

- [Digitizing Basics](#) **17**
- [Line Width and Style](#) **17**
- [Frequent Commands](#) **17**
- [Curve Smoothing](#) **18**
- [Right-Click Popup Menu](#) **18**
- [Fill Region](#) **18**
- [Margins](#) **19**
- [Chemistry Components](#) **19**
- [Drawing Common Shapes](#) **19**
- [Fan Lines](#) **20**

[Labels](#) **24**

[Rulers](#) **24**

[Appendix – NIST Data Center](#) **28**

Quick-Guide: Shortcuts

Guide Context

Bold face type – Reference to shortcut commands

“Courier New” font – Reference to the PED Editor Menu

“MB” – Mouse **B**utton

Definition of “Key point” – Any decoration anchors, curve vertexes, curve and/or line intersections, corners of diagrams, and segment midpoints

Definition of “Selection” – A user’s selection is indicated by the **green** highlight color. Predicted action is indicated by the **red** highlight color

Navigation

q	Moves mouse cursor to nearest key point
w	Moves mouse cursor to nearest curve and/or line segment
Shift + Q	Cursor Selects the nearest key point or label <ul style="list-style-type: none">○ Hold “Shift” and press “Q” – Selects and cycles nearby key points and labels
Shift + W	Cursor selects the nearest line segment or ruler
Escape	Deselects the current selection
Enter	Moves cursor position to coordinates
Ctrl + H	Hides scanned image underlay
Ctrl + B	Image maximizes to PED Editor window
Ctrl + +	Zoom-in at mouse cursor
Ctrl + -	Zoom-out at mouse cursor
Up, down, left, right	Moves the mouse in small increments

Post-Selection

x , or Left MB	Creates new vertex point
Right MB	Opens the <u>Popup Menu</u>
Delete	Removes any selected object
Shift + V	Moves <u>only</u> the <u>selected</u> line or label
v	Moves <u>all</u> lines and labels at that key point
[Moves selection of a vertex to the <u>left</u>
]	Moves selection of a vertex to the <u>right</u>

- o** Toggles closure of a curve
- e** Opens the Editing Menu for the selected label, axis ruler, or tie lines
- s** Toggles curve smoothing
- ,** Toggles point smoothing
- c** Creates new copy of the selection
- d** Duplicates the currently selected line or label properties to the previously selected line or label properties
- >** Adds Right arrowhead
- <** Adds Left arrowhead
- r** Opens the Color Menu
- t** Creates new label at mouse cursor.
Label editing: HTML formatting wraps text changes inside brackets, i.e.
<i><u>Sample Label</i></u> reveals: **Sample Label**

Help File Available on the main application window

PED Editor User Guide

The PED (*Phase Equilibria Diagram*) Editor is a Java© program useful for digitizing images of existing or new phase diagrams, or other two-dimensional drawings. Digitization is straightforward: left-click with the mouse to complete a trace of the diagram's lines and curves. Digitized diagrams are saved under a “.PED” file format.

The PED Editor was originally created for use at NIST to prepare the graphics files for Standard Reference Database 31, *Phase Equilibria Diagrams* (<http://www.nist.gov/srd/nist31.cfm>). Researchers who use this software to draw and publish figures should include proper attribution for the software tool (contact phase2@nist.gov). In the event that published diagrams are chosen for inclusion in SRD 31, provision of the .ped file(s) will expedite the process. Conventions used by the SRD 31 Data Center are included in the Appendix.

Users are encouraged to access the Help file available on the main application window.

Getting Started

1. In order to digitize diagrams from a hard copy, a scanner or equivalent image capture hardware is required.
2. Scan the diagram and save the image file in an easy to find location
 - Supported image formats: JPEG, GIF, and PNG
3. Initializing the program prompts three choices:

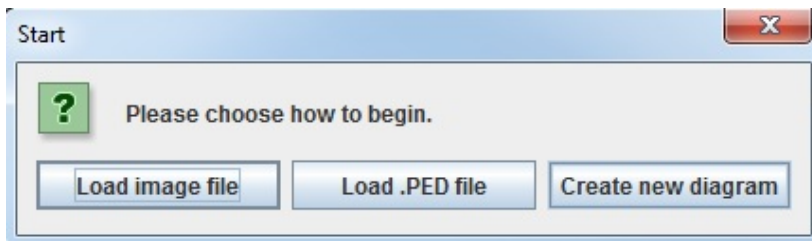

4. Select “Load image file,” navigate to your previously saved image file, and select Open

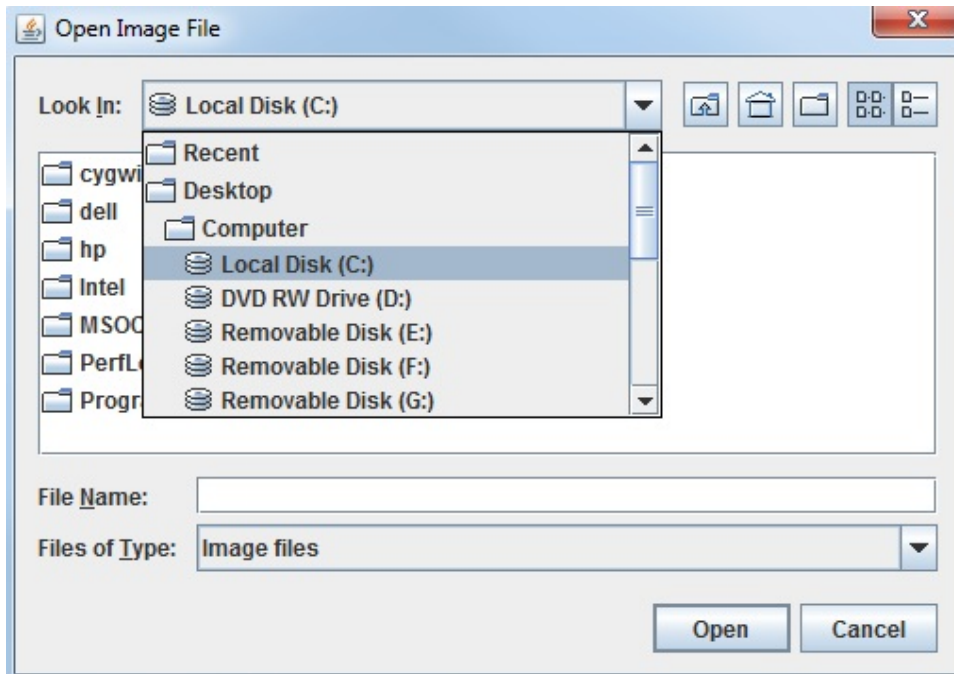

5. Opening your image file prompts selection of the diagram's format. The choice of format will determine how the PED editor begins the digitization.

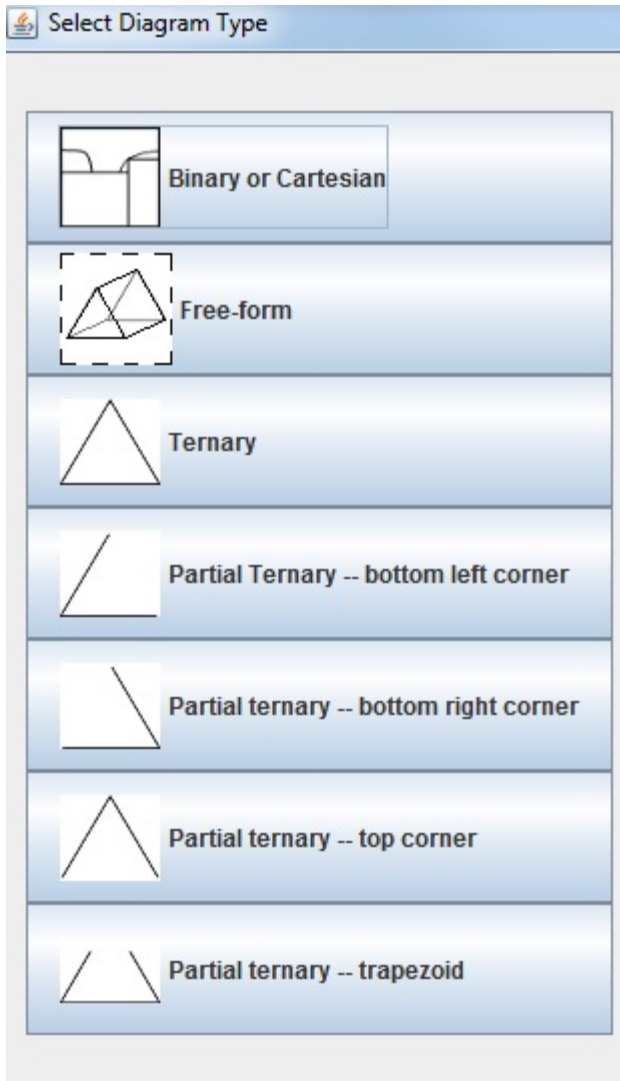

6. How-to-Scale Instructions

- [Pg. 6 – Binary or Cartesian Diagrams](#)
- [Pg. 8 – Ternary Diagrams](#)
- [Pg. 10 – Partial Ternary Diagrams \(bottom left, bottom right, & top\)](#)
- [Pg. 12 – Partial Ternary Diagrams \(trapezoid\)](#)
- [Pg. 15 – Free-form Diagrams](#)

7. [Digitization Reference: Pg. 17](#)

Binary Diagram

1. Select “Binary or Cartesian” for the example diagram below:

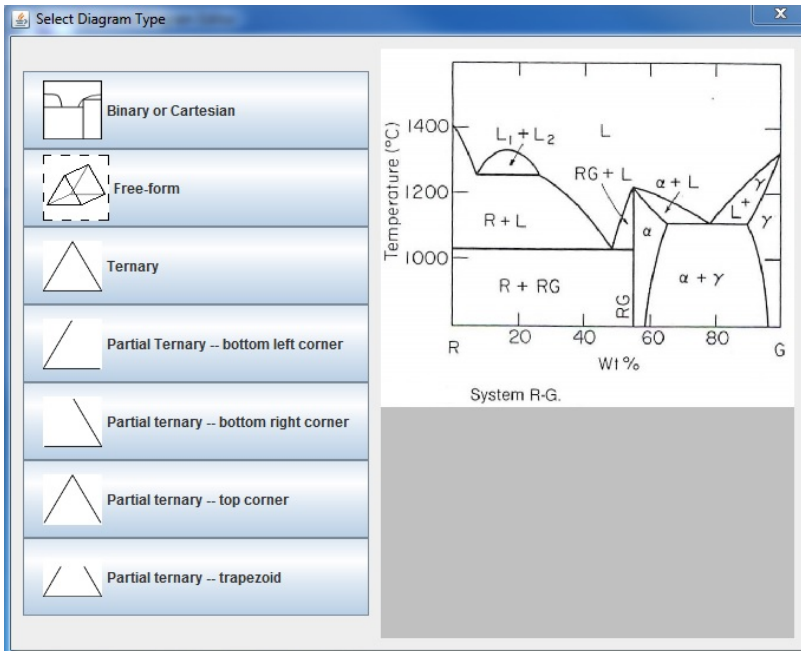

2. The program opens in a new window containing the scanned image:

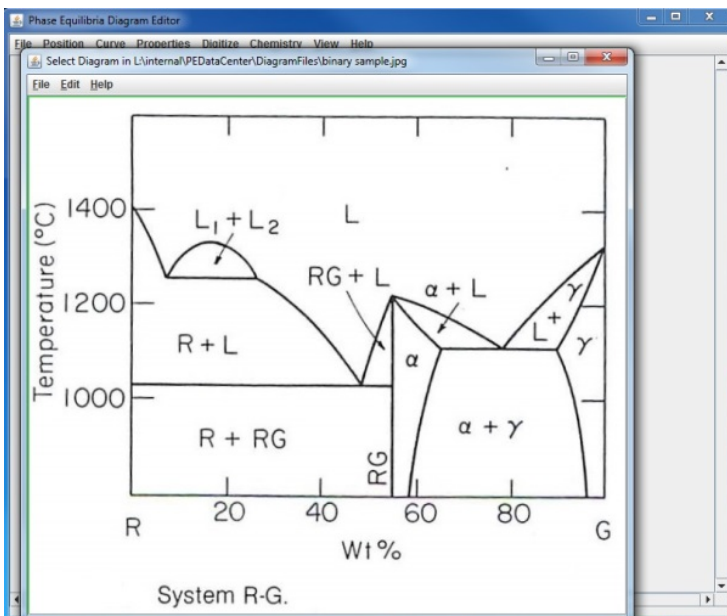

3. Within the scanned image, **left-click** with the mouse two (diagonally opposed), three, or four corners formed by the X and Y axes (Ex. **A** → **B** → **C**). The **red**-outline will follow your cursor as a preview while the **green**-outline is the actual selections made.

- Press **Delete** to delete corners. Use the arrow keys to adjust the most recently added corner. Press **Enter** on the keyboard when finished.

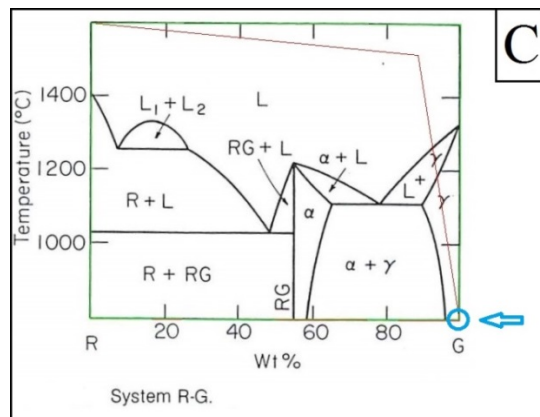
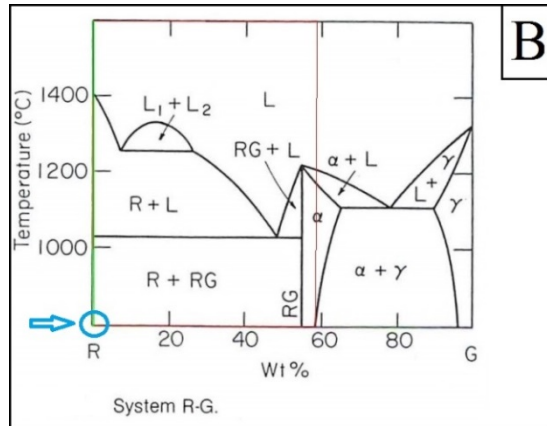
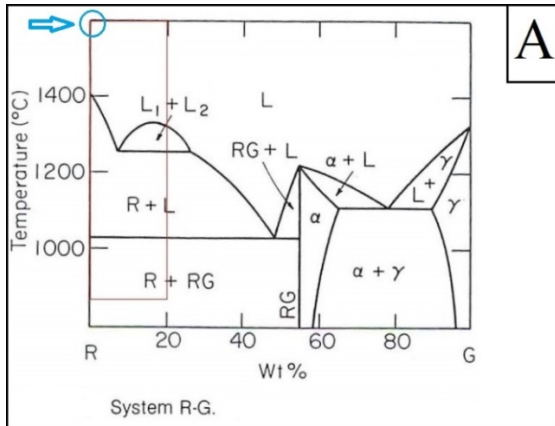

4. After pressing **Enter**, the scaling box is displayed for adjusting the graph's domains. By default, scale values run 0 to 1. Adjust these values now, or later under the "Properties/Scale" Menu within the PED editor

Figure 4: Screenshot of the "Edit values" dialog box. The text inside reads: "Enter the graph domain. Fractions are allowed. If you enter percentages, you must include the percent sign. For logarithmic axes, enter the range of logarithms (e.g. -2 to 2 for 10^{-2} to 10^2). You can also set the domain later, using the Properties/Scale menu." The input fields are: Left X value: 0, Right X value: 1, Bottom Y value: 0, Top Y value: 1. An arrow points from this dialog to the next one.

Figure 5: Screenshot of the "Edit values" dialog box after adjustments. The text inside reads: "Enter the graph domain. Fractions are allowed. If you enter percentages, you must include the percent sign. For logarithmic axes, enter the range of logarithms (e.g. -2 to 2 for 10^{-2} to 10^2). You can also set the domain later, using the Properties/Scale menu." The input fields are: Left X value: 0, Right X value: 100, Bottom Y value: 800, Top Y value: 1600.

5. The binary example diagram after scale adjustments:

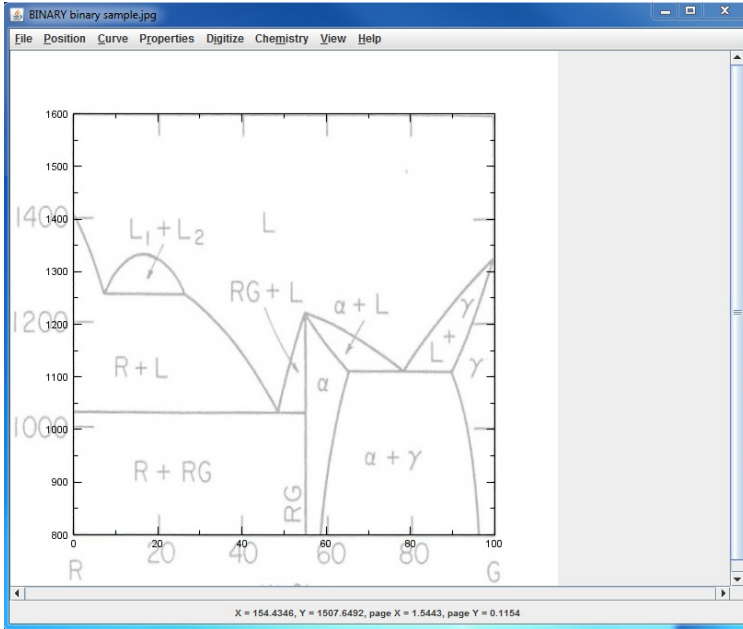

6. [Digitization Reference: Pg.17](#)

Ternary Diagram

1. Select "Ternary" for the example diagram below:

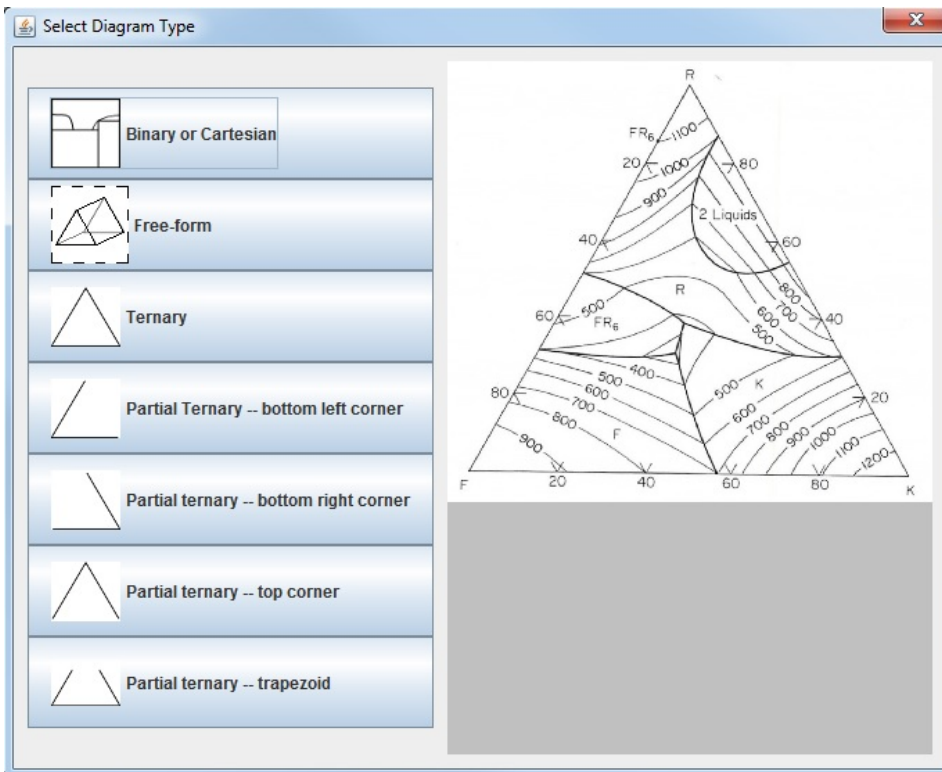

2. Within the scanned image, **left-click** three corners of the triangle (Ex. **A** → **B** → **C**). The **red**-outline follows your cursor as a preview while the **green**-outline is the selections made.

- Press **Delete** to delete corners. Press **Enter** when finished

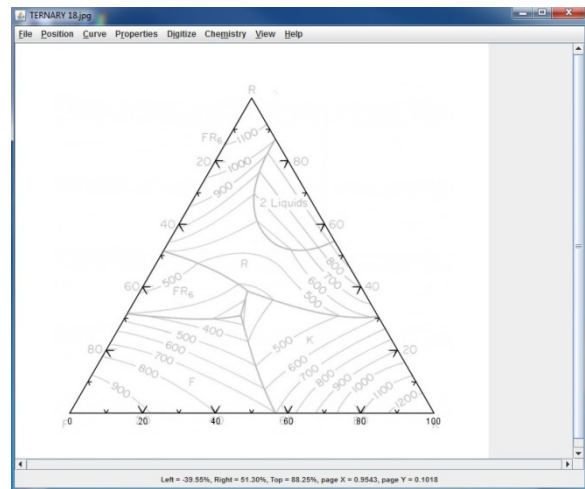
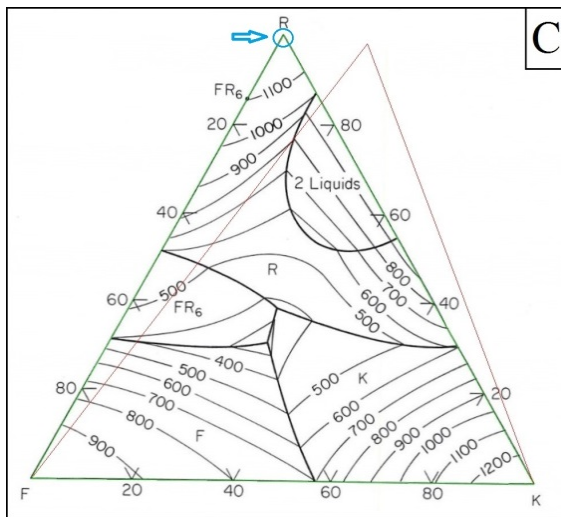
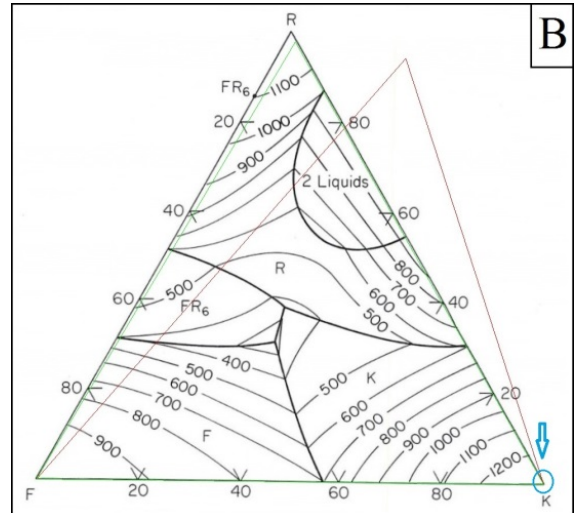
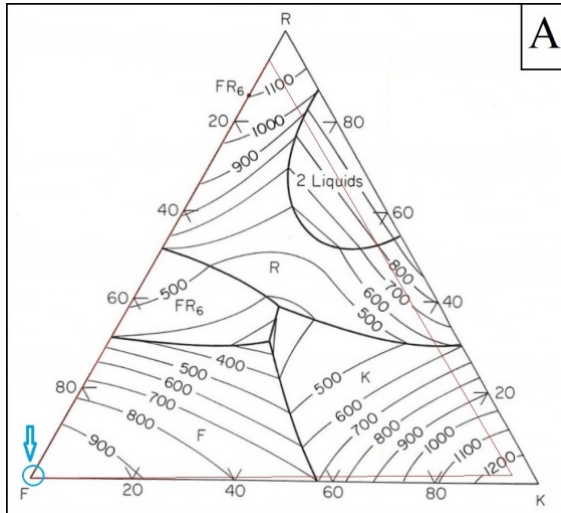

3. After pressing **Enter**, the default scale is percentage values 0 to 100. Adjust these numbers from the “Properties/Scale” Menu (See also [Rulers on pg. 24](#))

4. [Digitization Reference: Pg.17](#)

Partial Ternary Diagram

1. Select “Partial ternary – bottom left corner” for the example diagram below:

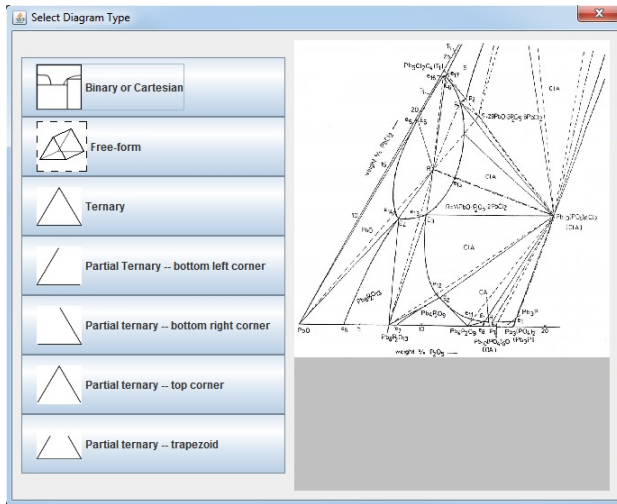

2. Depending on the partial ternary format, the decision where to select the three corners of a diagram's domain will vary (Ex. $A \rightarrow B \rightarrow C$). This diagram's first scale point is 100:0 PbO:P₂O₅ (panel A), 80:20 PbO:P₂O₅ (panel B) and 75:25 PbO:PbCl₂ (panel C)

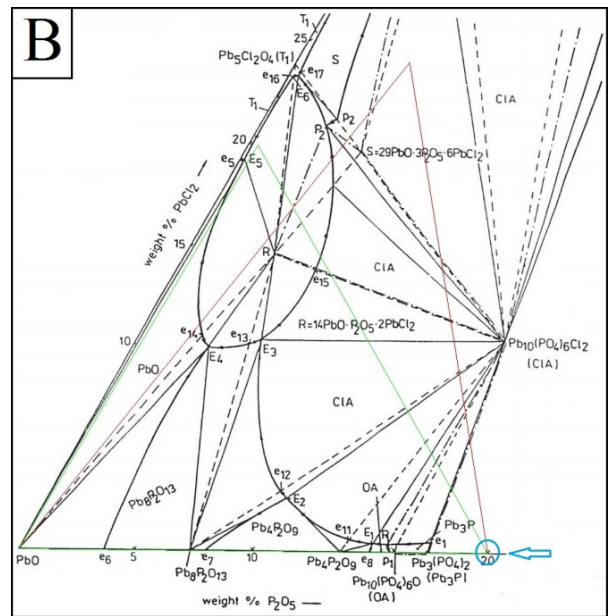
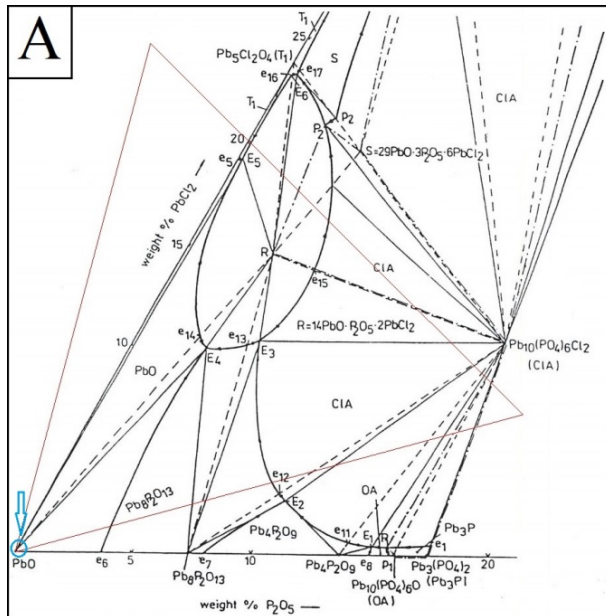

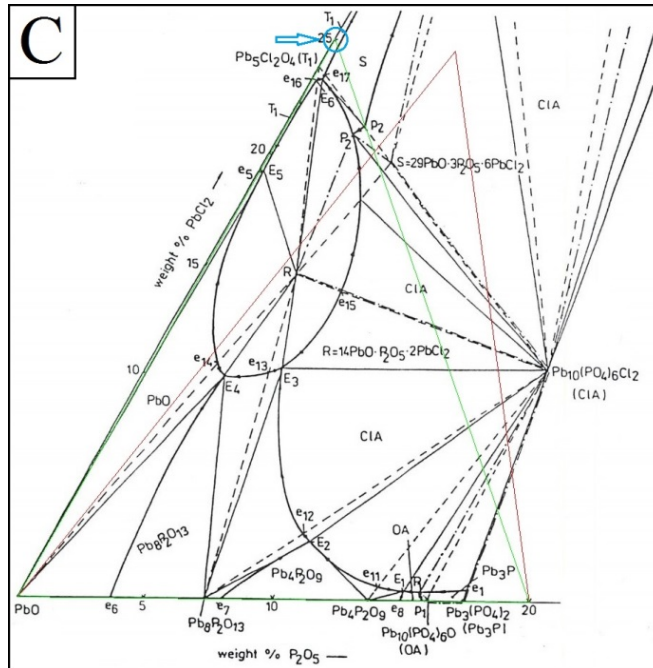

3. Press **Enter** after completing scale selections. A new dialog box is presented with two fields for editing, “Bottom” and “Left.” These terms refer to the outer edges of the partial ternary diagram. The percentage value is based on a fraction of the total ternary scale.

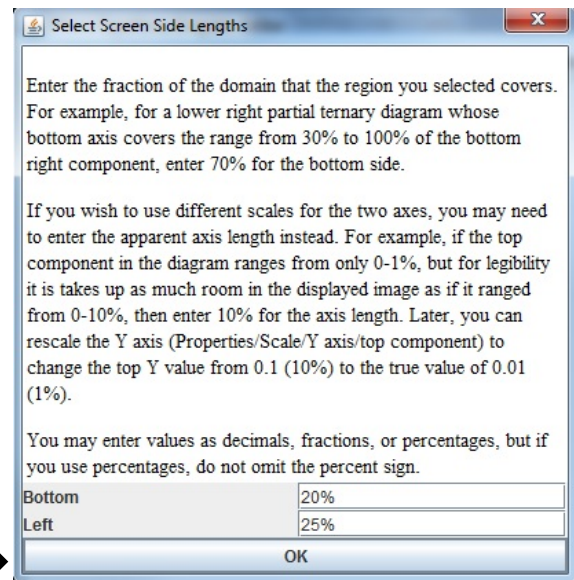
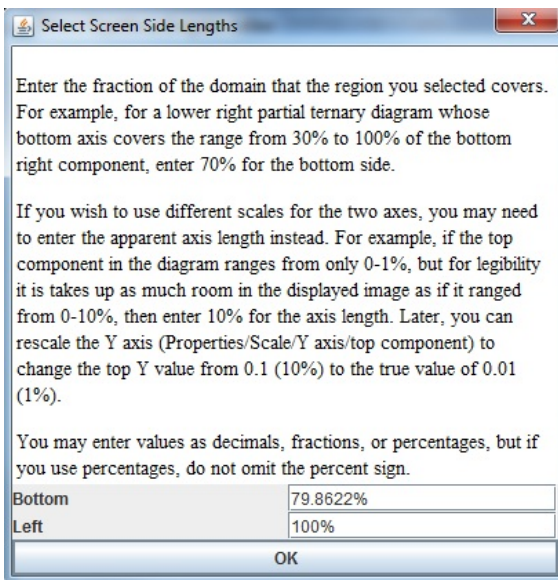

4. The example partial ternary diagram for “20% bottom” and “25% left:”

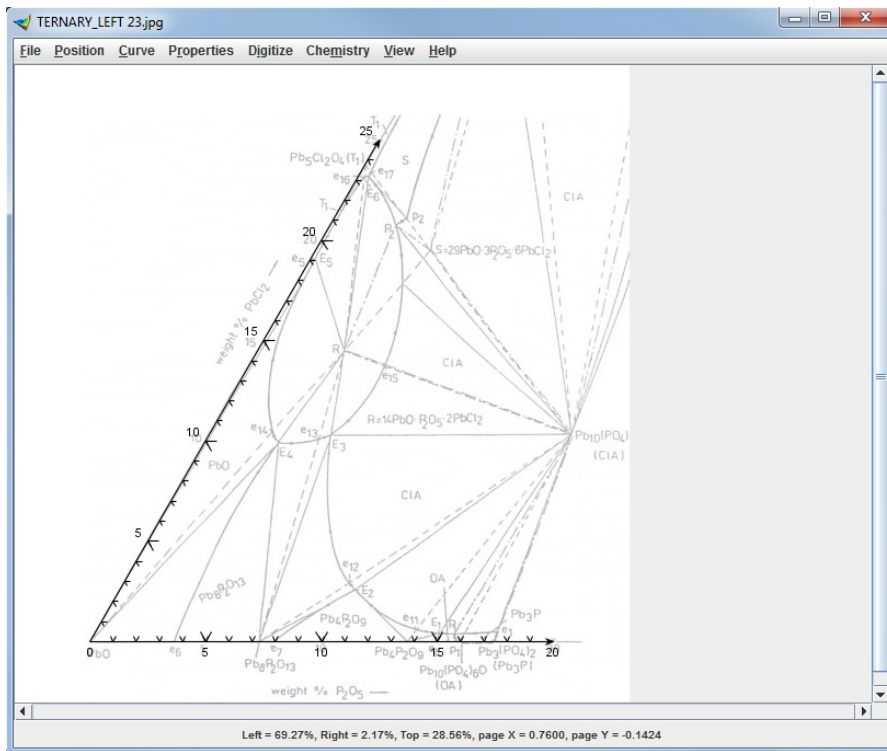

5. [Digitization Reference: Pg.17](#)

Partial Ternary Diagram – Trapezoid

1. Select “Partial ternary – trapezoid” for the example diagram below:

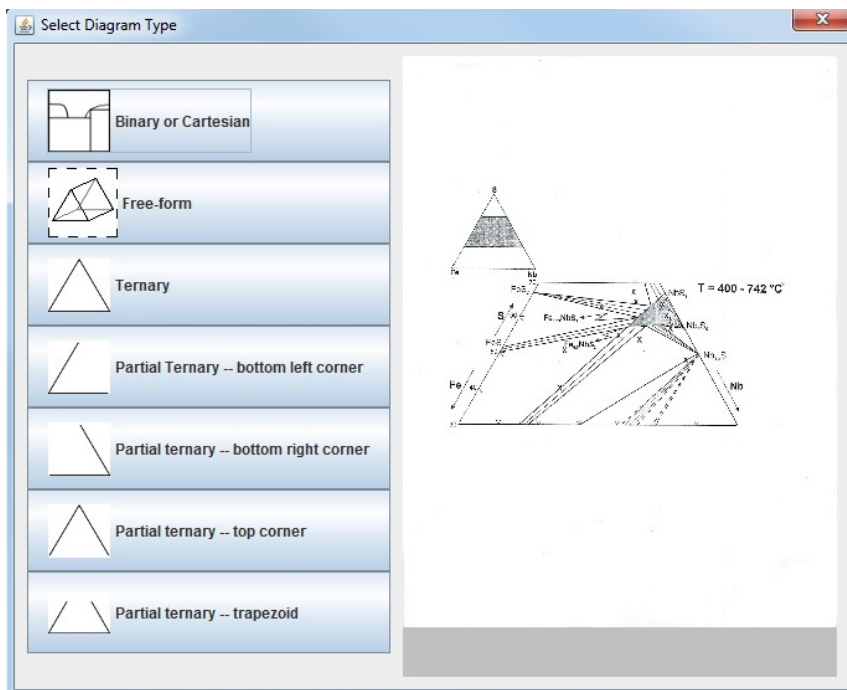

2. Trapezoidal ternary diagram formats require additional bounding parameters (A → B → C → D)

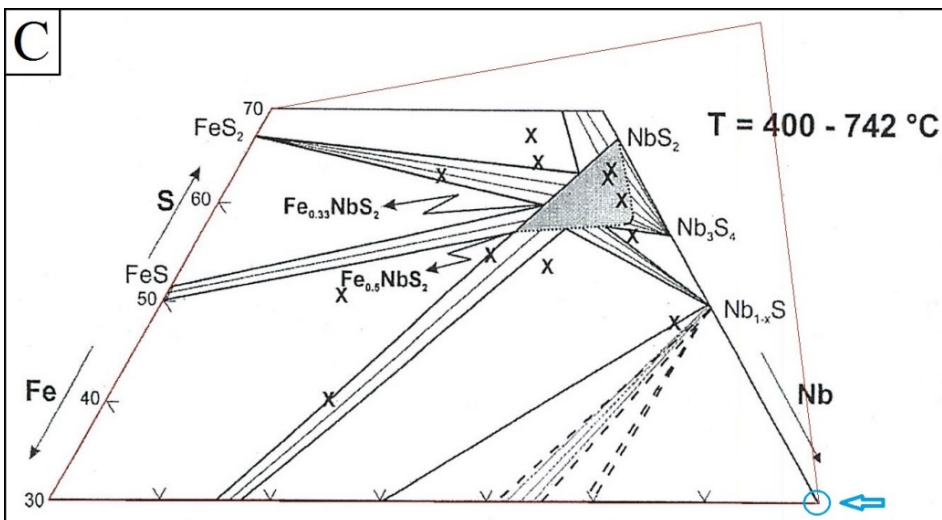
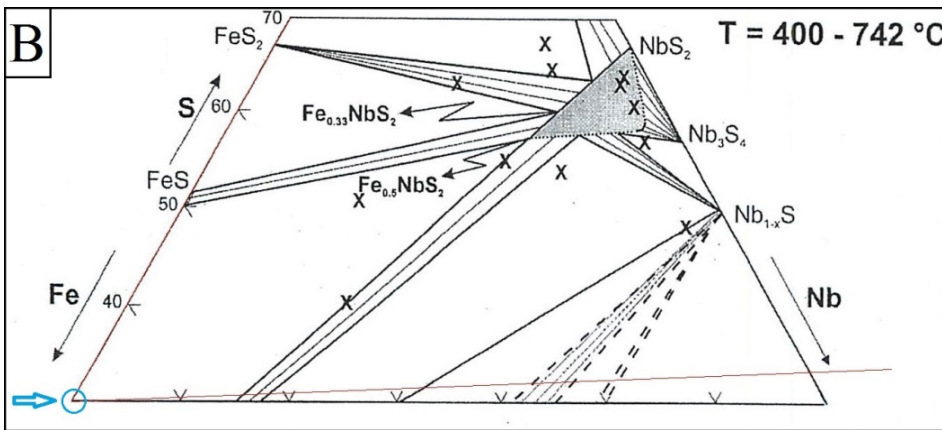
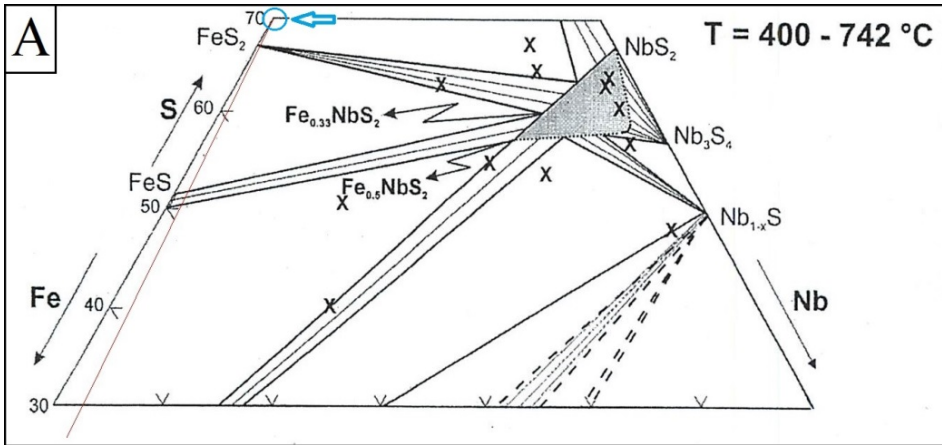

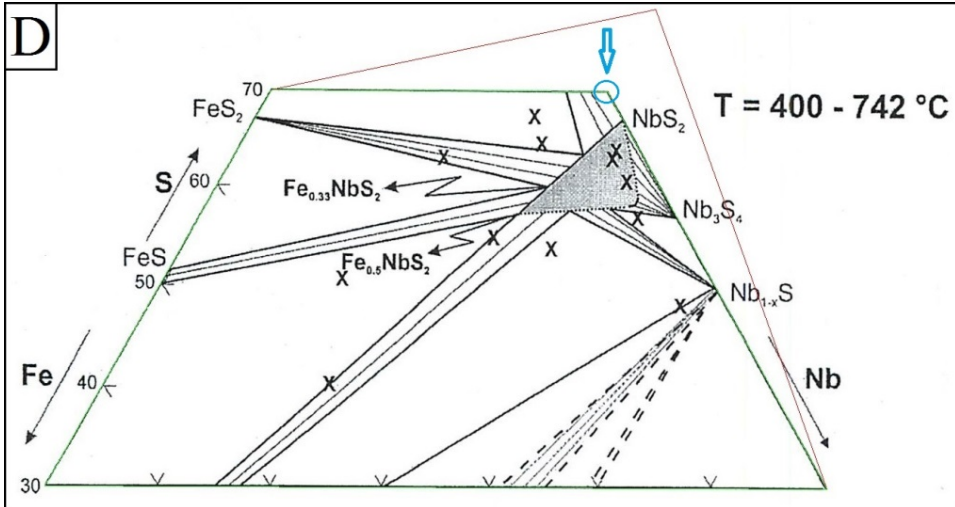

3. Press **Enter** after completing selection. A new box prompts four fields for editing diagram boundaries based on percentages of the whole:

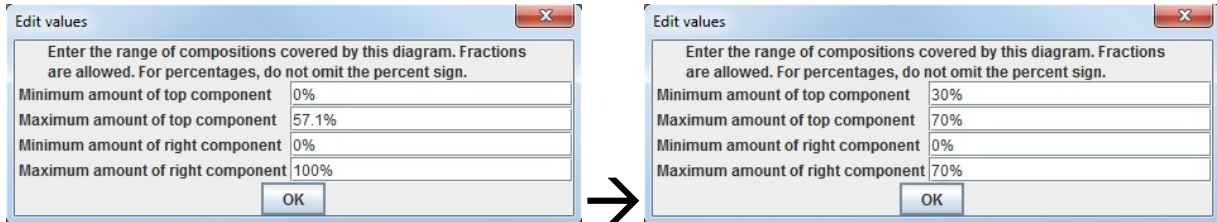

4. The example partial ternary diagram with the corrected scale values:

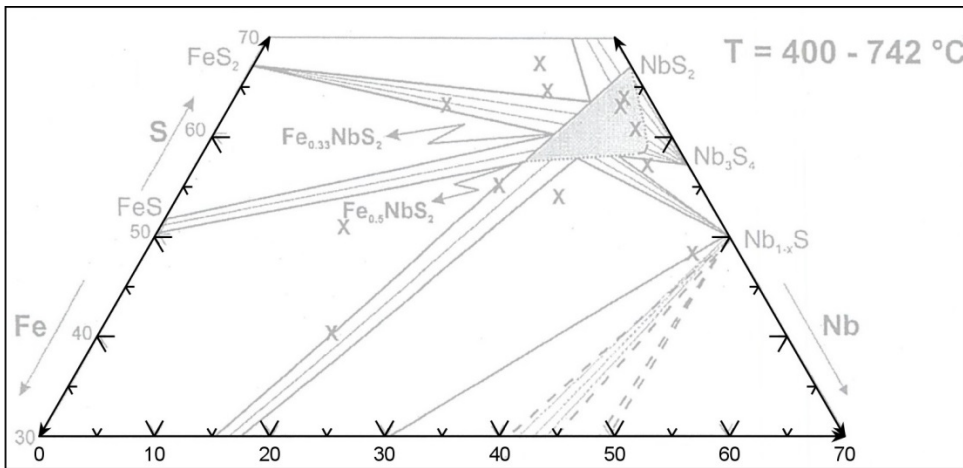

5. [Digitization reference: pg.17](#)

Free-form Diagrams

1. Free-form diagrams do not fit the available diagram type such as this schematic diagram:

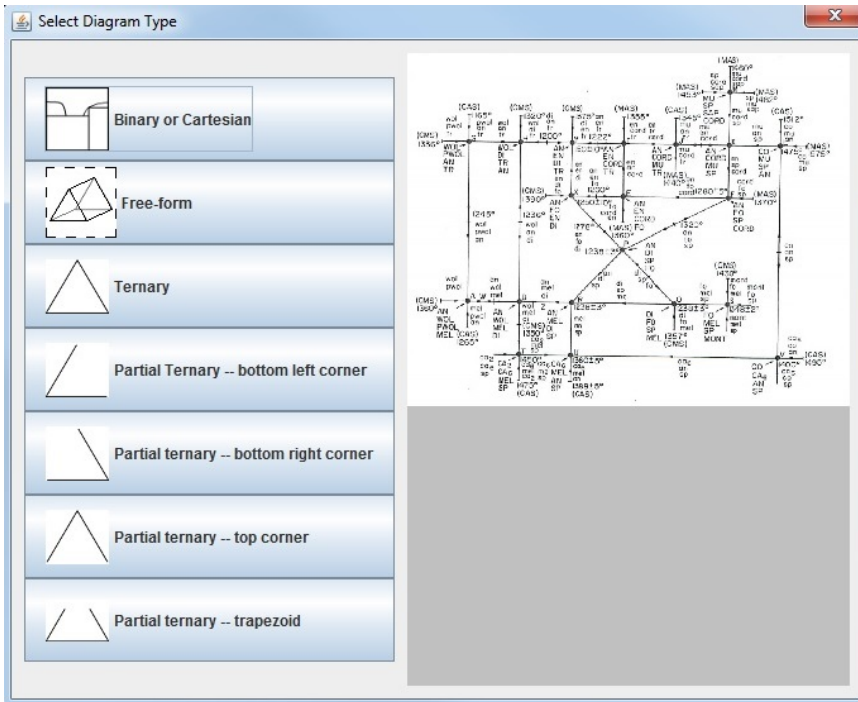

2. By default, the entirety of the scanned image indicated by the green-outline is included as the digitizing region:

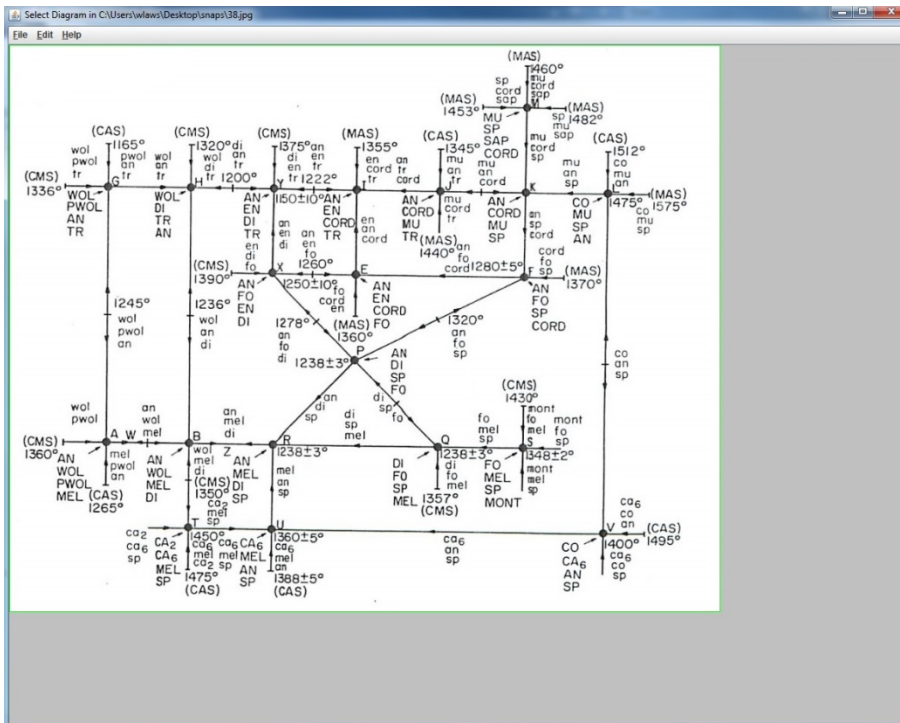

3. Below, a slightly smaller bounded region was selected, indicated by the red-outline.

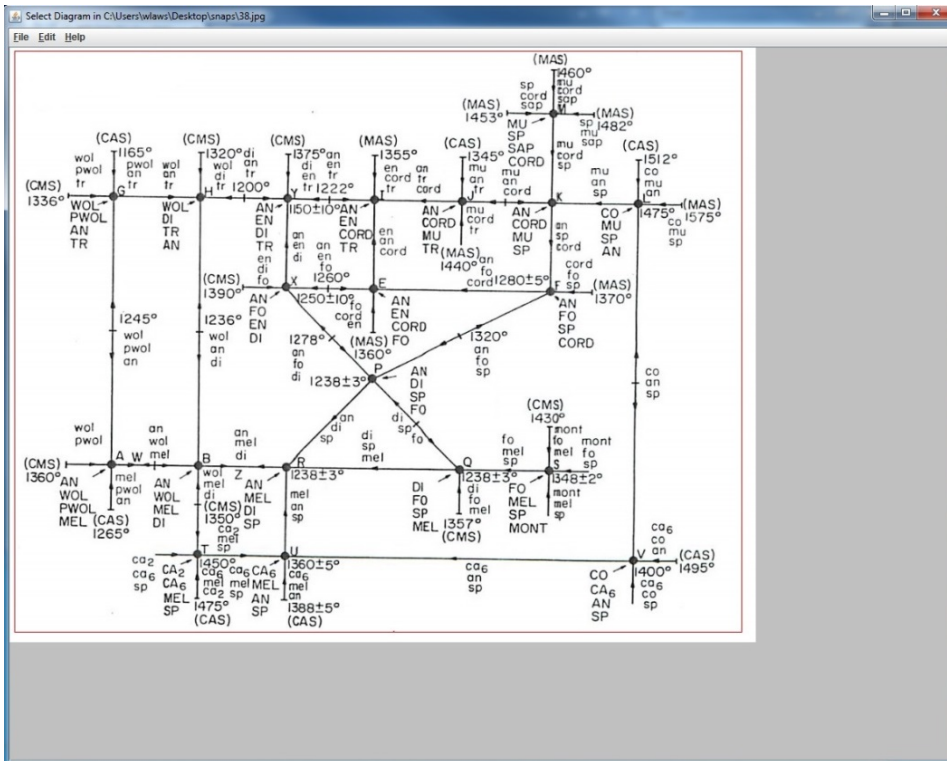

4. After editing the diagram's bounds, press **Enter** to launch the PED Editor:

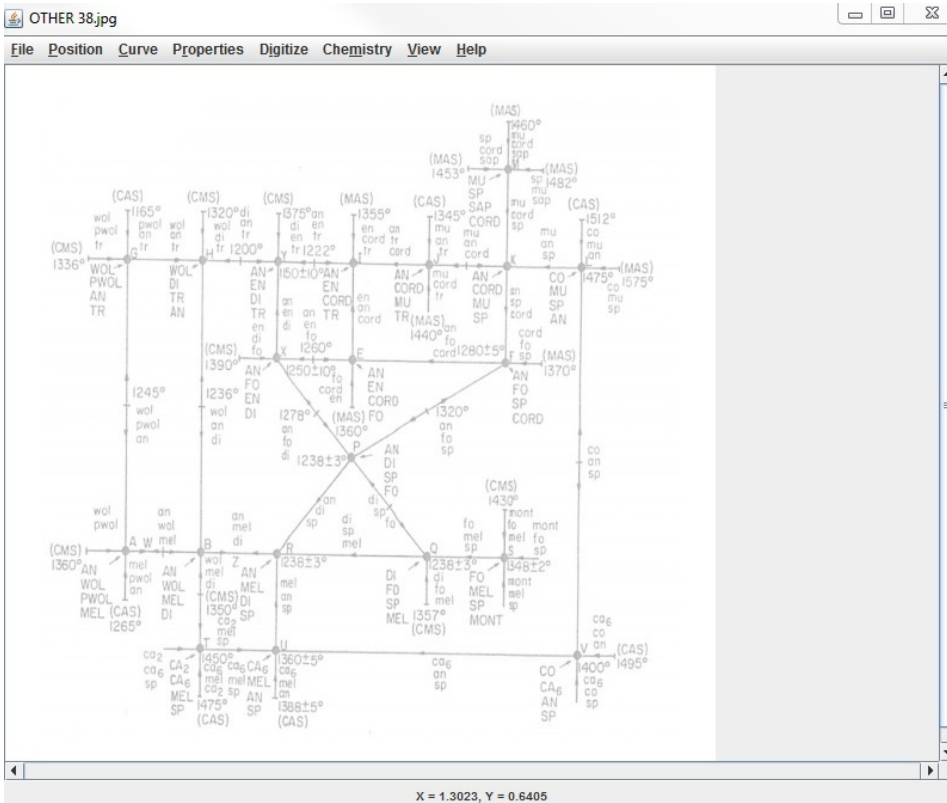

Digitization

1. **Left-Click** with the mouse to create new line and/or curve segments with the image scan as a trace reference. Deselect with either the **Esc** button or **Right-click** → Deselect
 - Horizontal and vertical lines: Create a new vertex and hold down “**Shift**”. Move the mouse to the desired location as the editor will auto-adjust to the vertical or horizontal plane indicated by **dark-orange** line indicator.
2. The PED editor menu under the “Curve” tab can alter a line’s width or style:

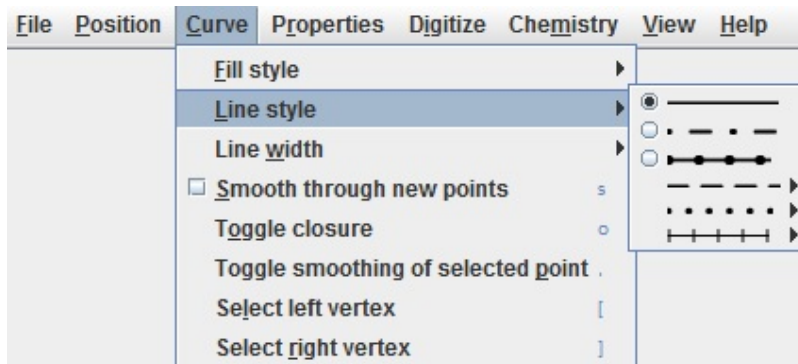
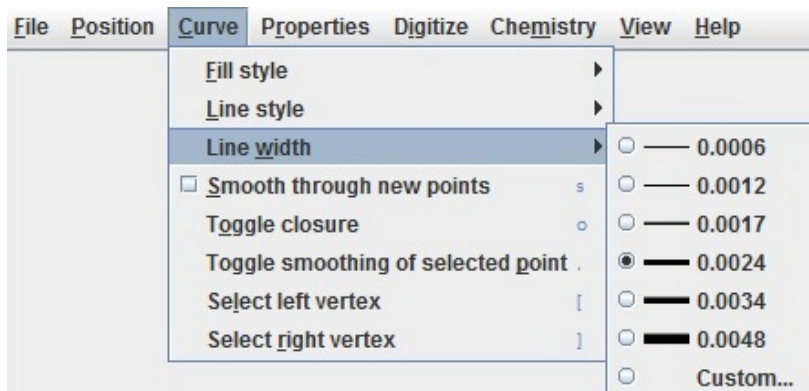

3. From the [Quick-Guide, pg.2](#): **w**, **Shift+W**, **q** and **Shift+Q** are the primary keystrokes for label and curve management
 - “**w**”: Moves the cursor to only lines or axis scales
 - “**q**”: Moves the cursor to closest any key point, vertex, or label
 - Hold “Shift,” and press “**w**” or “**q**”: Selects the nearest key point and/or line
 - Hold “Shift,” and press “**q**”: Continues to select nearby key points from cursor
 - Arrowheads (shortcut “<” or “>”): Move cursor to the desired location, then press the relevant arrowhead on the keyboard

4. Curve Smoothing: Under the PED Menu “Curve/Smooth through new points ,” toggle this option to create curved lines between three or more vertexes

- Toggle Point Smoothing: The **comma** button will only smooth a selected vertex. In the example below, vertexes are explicitly displayed which contain both the smooth and segmented vertexes on a single curve.

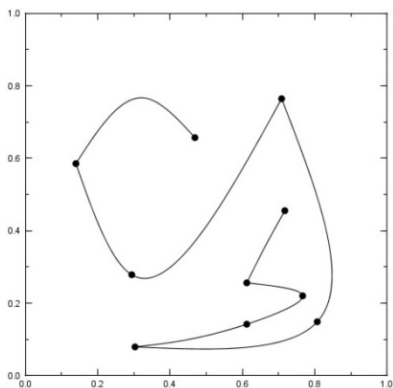

5. Right-Click Popup Menu

- Magnification is accomplished by two methods: Hold the **left mouse** button then drag the **red** box around the investigated region. The second is navigating to the Popup Menu and selecting Zoom in (**Ctrl+ +**), or Zoom out (**Ctrl + -**).

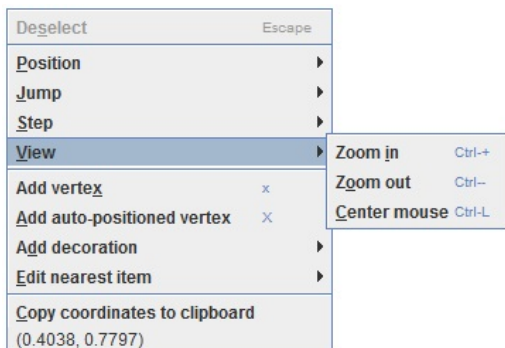

6. “Curve/Fill style” under the PED menu will add a fill pattern for closed curves.

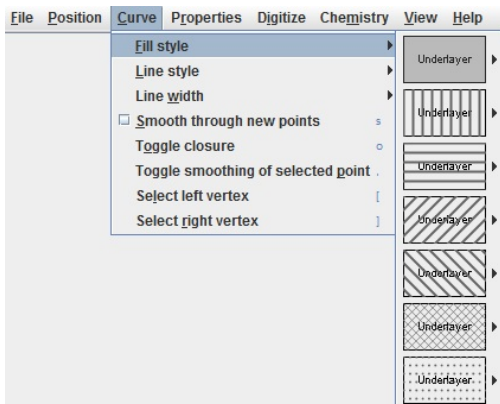

- Filling a region involves first closing the boundaries. The vertexes for a curve are displayed below:

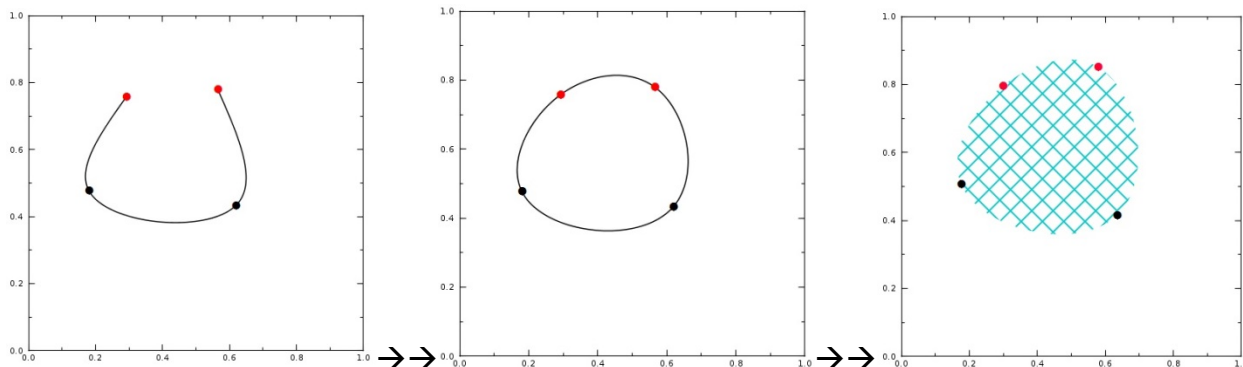

- First, highlight to select the curve (**Shift+W**) and press “o” to close the curve. Then, select a fill style from the PED menu

7. *Margins*: Under the **Properties** menu, the size of a margin is based as a fraction of the core diagrams height and length visibly displayed as white space surrounded by the gray, unworked region.

8. *Chemistry Components*

- This feature under **Chemistry/Components** in the PED editor identifies the binary or ternary diagram chemical components
- Chemical formula syntax: Type simple chemical formulas where numbers may be entered as integers, fractions, fixed-point decimals, or percentages ie. for a binary diagram containing the chemistry of $\text{In}_2\text{O}_3 : \text{MoO}_3$ is entered as “In2O3” for the “left” component and “MoO3” as the “right” component
- To locate a chemical coordinate: Press **Enter** on the keyboard to set the coordinate which will move the mouse cursor’s position to the concentration percentages

9. *Drawing common shapes*

- **Rectangle**: Create a new vertex point, hold “**Shift**” and draw the first linear side. Continue holding “**Shift**” and draw the first 90° degree corner. Press “o” to toggle closure, hold “**Shift**”, and align the preview lines to form a rectangle
- **Circle**: Perfect circles are not supported, however, a close approximation is obtained using the same procedure to draw a rectangle. Toggle “Smooth through new points” and draw a square with the same process as for rectangles.

10. Fan Lines, or Tie Lines,

- **Right-click** the mouse to access the Popup Menu and navigate to “Add decoration” → “Tie lines,” then follow the on-screen instructions as duplicated below for three-point and four-point tie lines:

Three-point Tie Lines: The outside boundary is defined by two vertexes from one curve or line

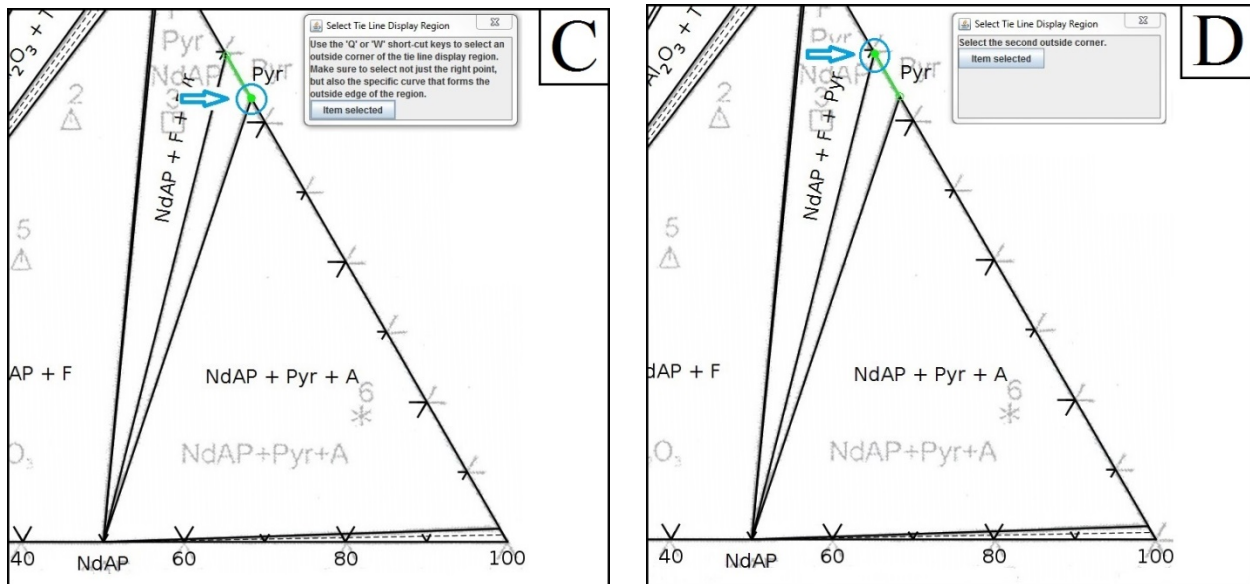
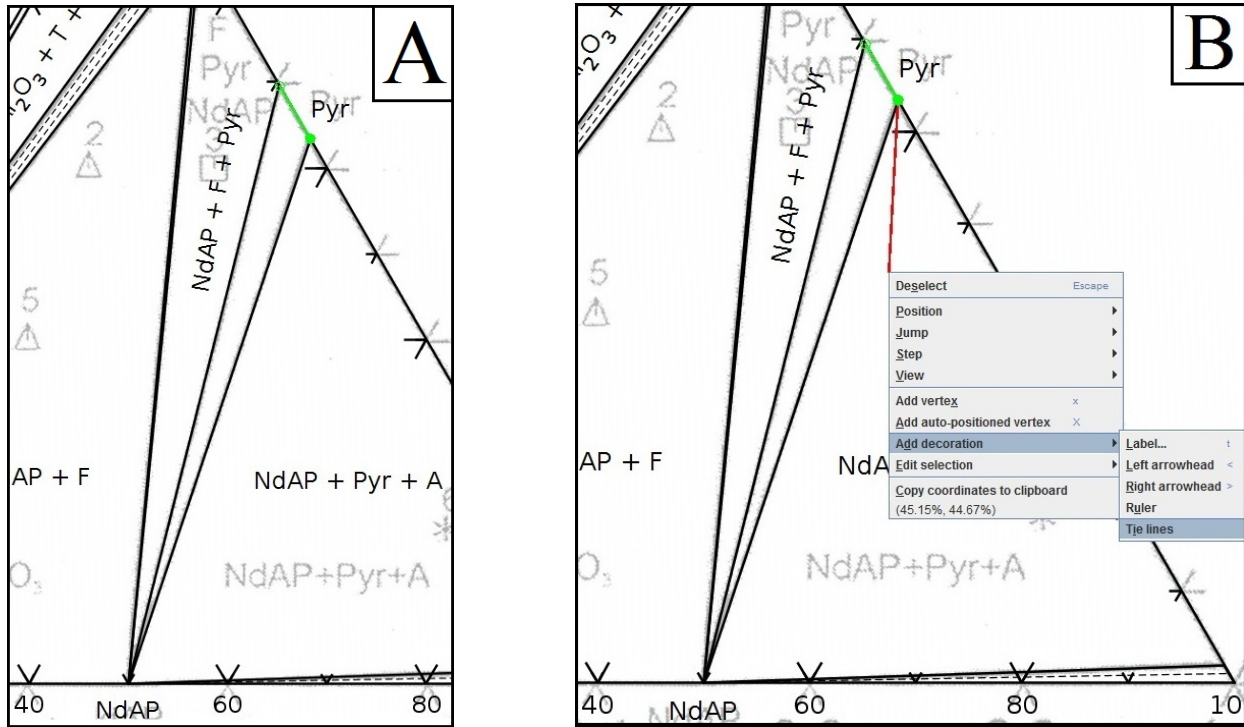

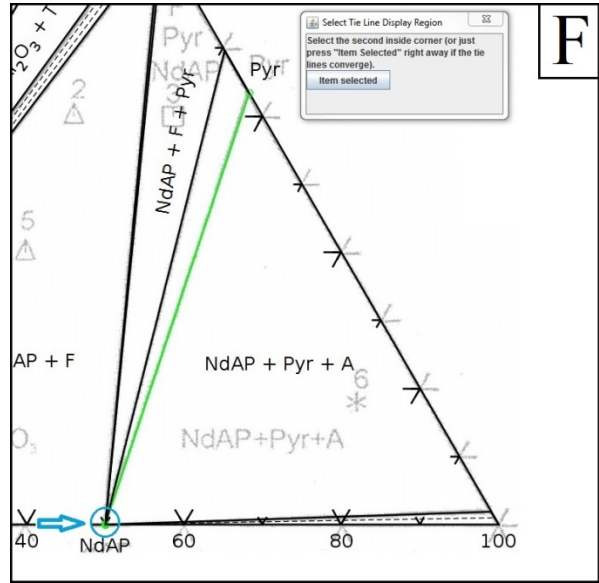
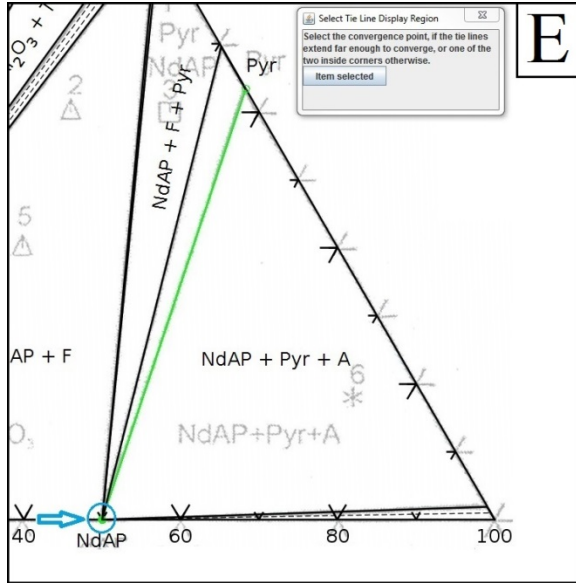

- Final tie-line result: indicate the number of tie lines to display and press **Enter**

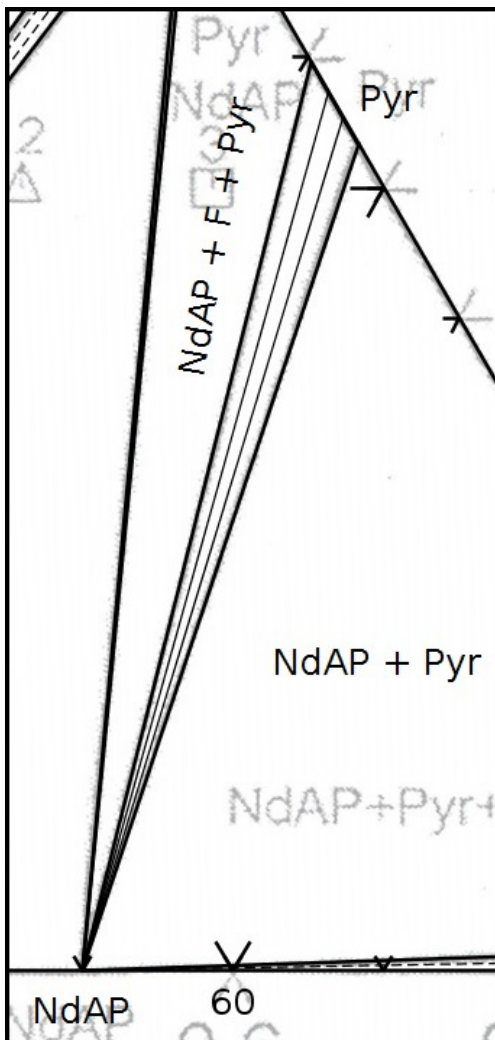

Four-point Tie Lines

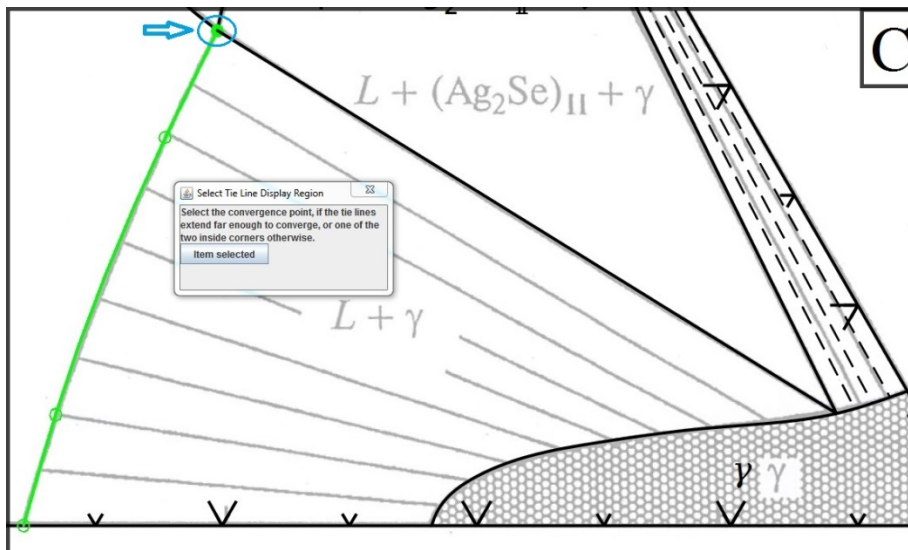
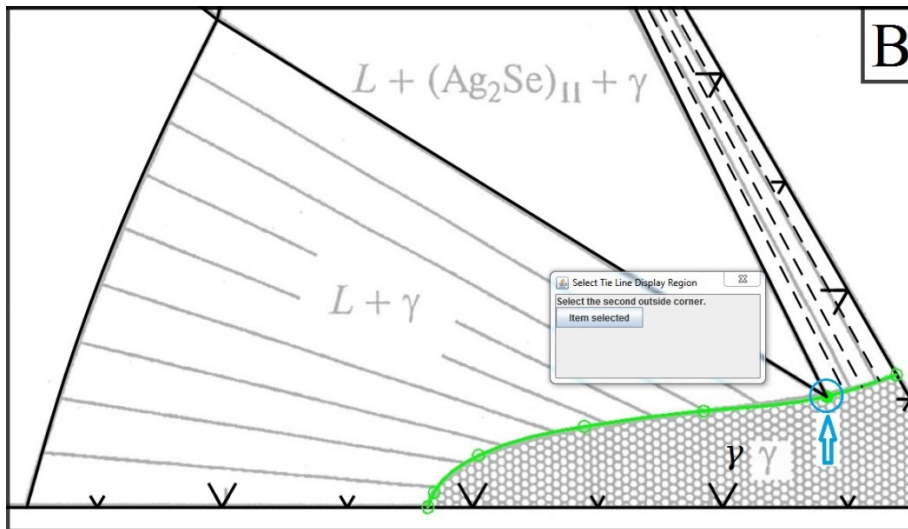
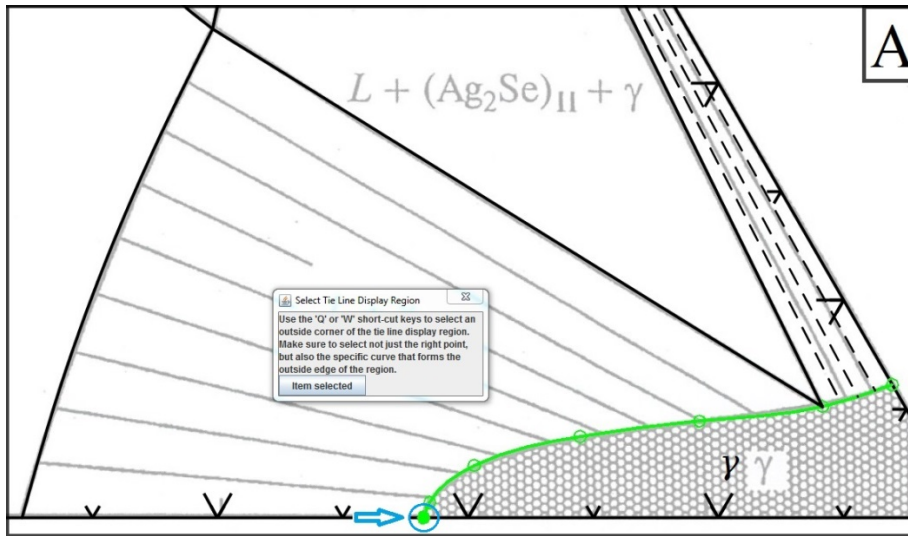

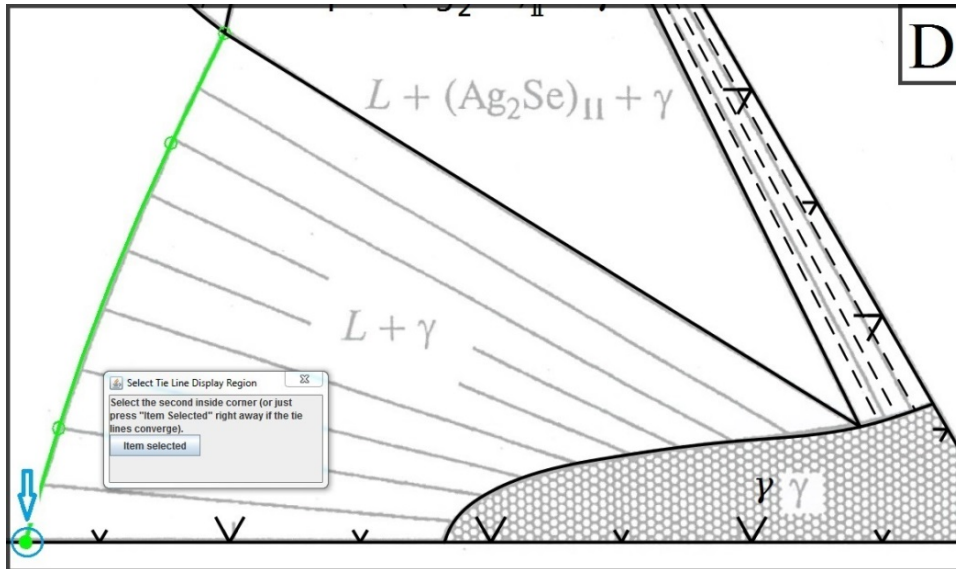

- Final tie-line result: indicate number of tie lines to display and press **Enter**

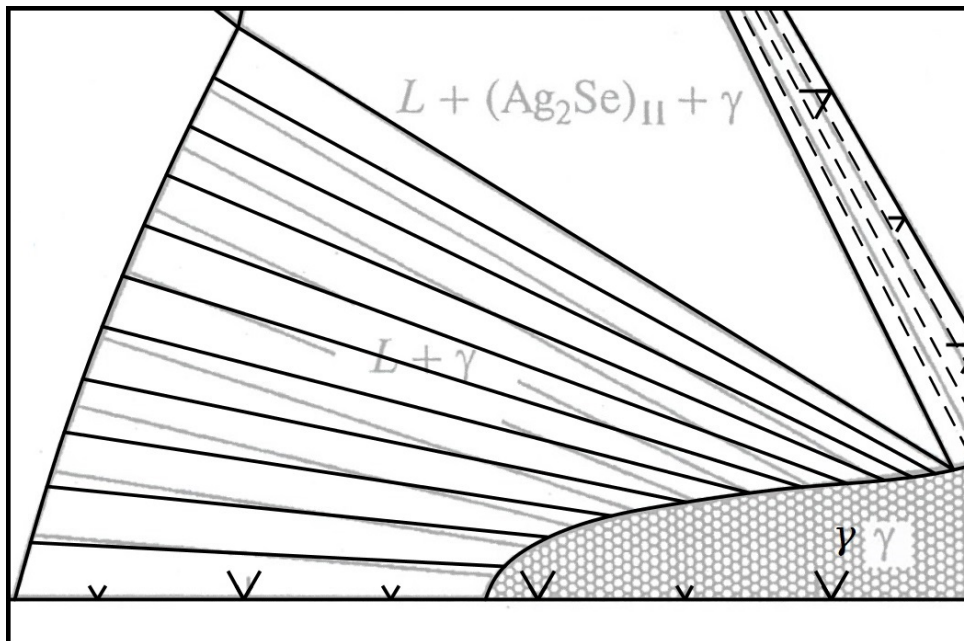

Labels

Labels (shortcut “t”) have three main features: size, format, and position anchor.

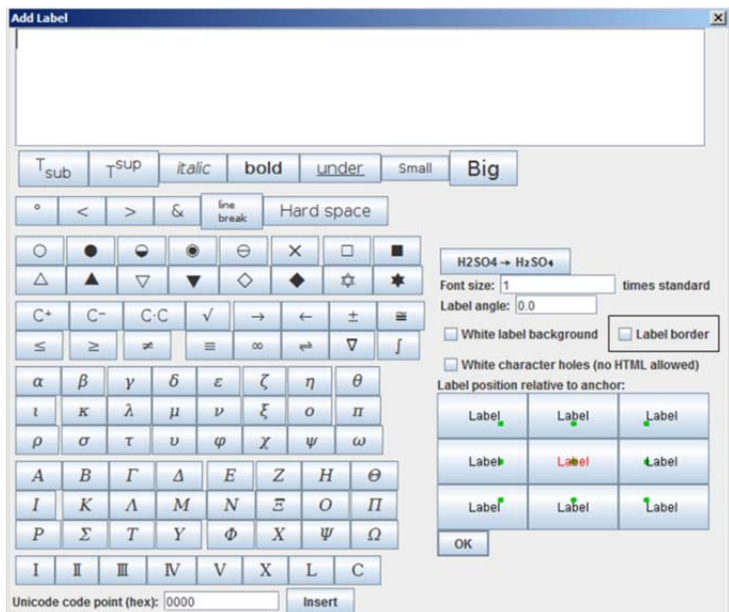

- Font size is handled relative to the scale of the drawing.
- Formatting is handled with HTML. Text changes occur inside brackets, i.e. `<i><u>Sample Label</u></i>` reveals: **Sample Label**
- Position anchors for the label are set in the center by default

Rulers

- The ruler menu contains two primary parts (Additional information for ruler’s is found under the PED Editor 2 menu “Help” file under “Rulers”)

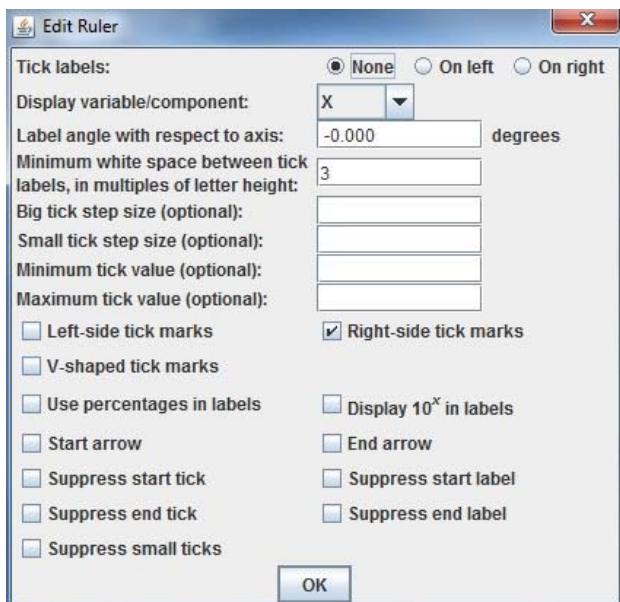

- Under the “Chemistry/Components” PED Editor Menu, a variable/component is defined as a diagram’s chemical system. The variable/component in terms of ruler function is what defines the ruler’s scale.
- The Minimum white space between tick labels, in multiples of letter height, defines the density of tick marks between their labels along the axis rulers. The most common input values in order of decreasing tick-mark density are 0, 1, and 5

Add New Rulers

- To add a different ruler, define a new variable then apply your variable to the ruler line: first, create a three-vertex curve in which two of the vertexes are on the same line while the third vertex does not, i.e. located perpendicular to the second vertex:

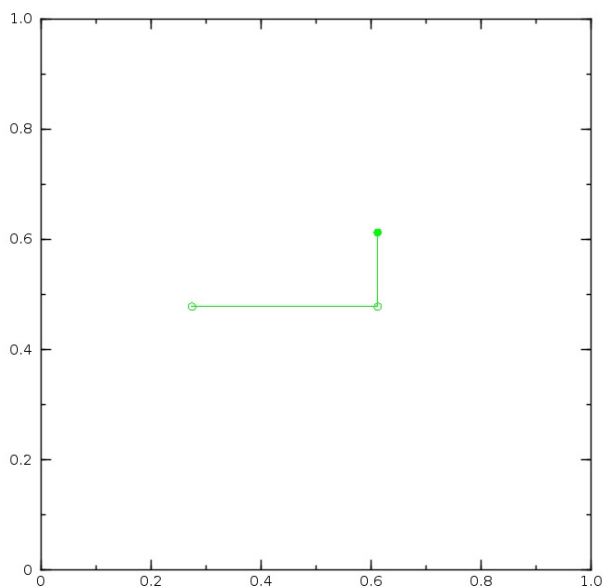

- Select the three-vertex curve and access the PED Editor Menu to add a new variable under “Properties/Variables/Add”

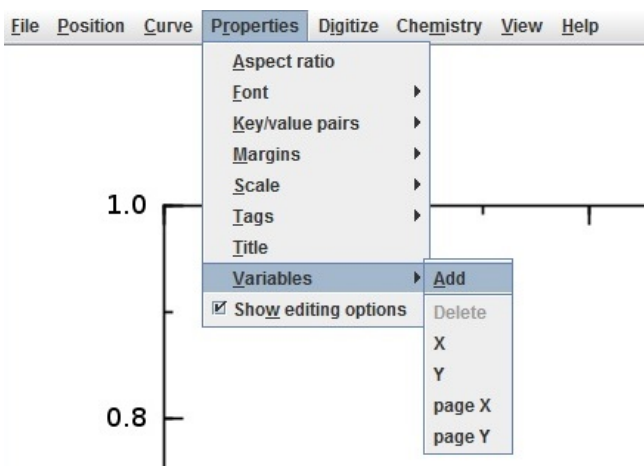

- Create a variable name for your new ruler, and then enter the values for each of the three vertexes beginning with the first vertex that was created. These values are the bounds for the custom scale and must be entered as a fraction or percentage, i.e. 0.2 or 20%.

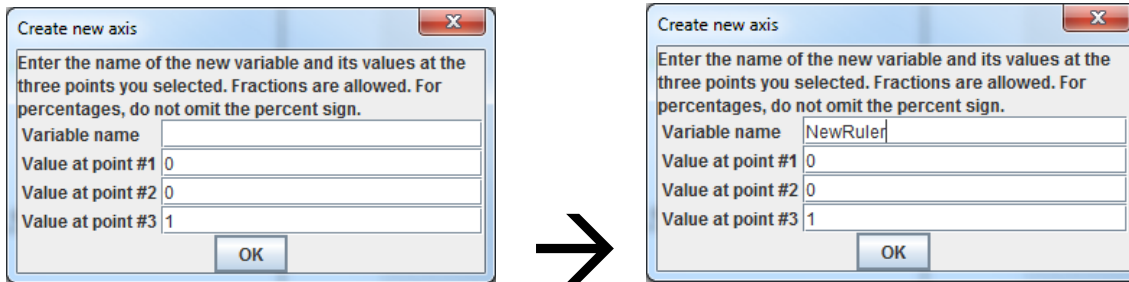

- The prompt for “display variable as a percentage” is displayed. This option only affects the status bar at the bottom of the PED Editor, not the ruler itself
- At this stage, a new variable has been created that is scaled based on the previously defined vertexes and their bounds. The next step is to create the line on which this variable will be applied
- Create a two vertex line. Alternatively, delete the third vertex from the previously created curve and use this line to display the new ruler if its position was already correct

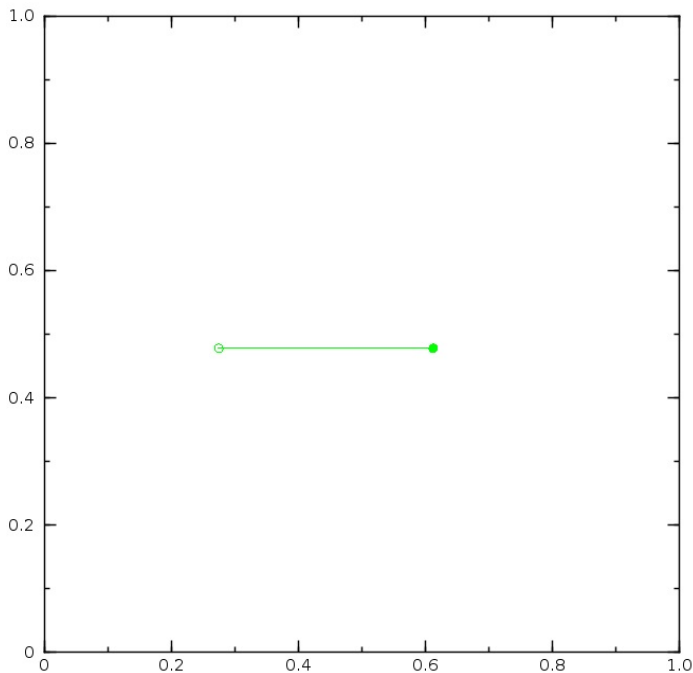

- Select your line and **right-click** to access the Popup Menu. Scroll to “Add Decoration” and choose “Ruler”

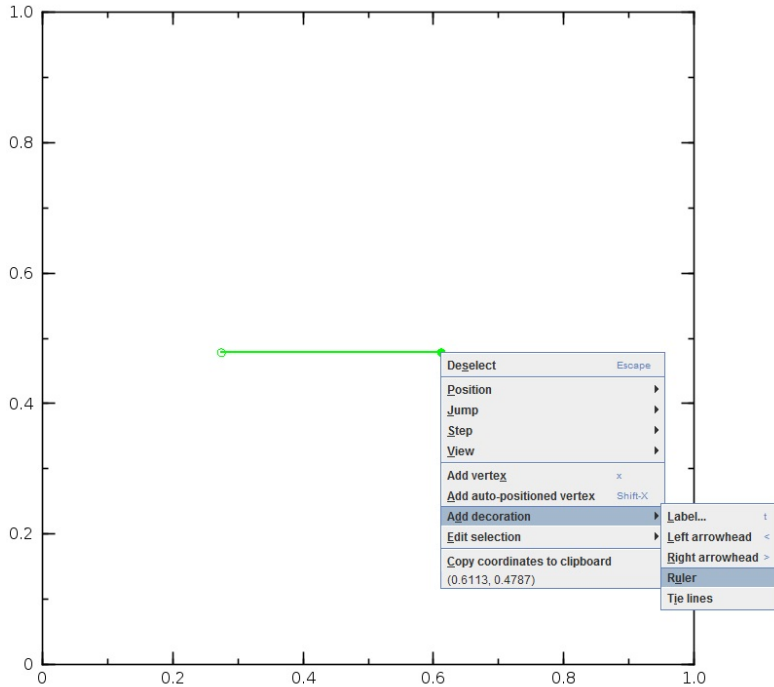

- The edit ruler menu is now opened. To customize this ruler, go to “Display variable/component” and access the drop-down menu which contains all of the applied variables for this diagram file. Choose your custom variable, edit any display options for the new ruler, and press OK.

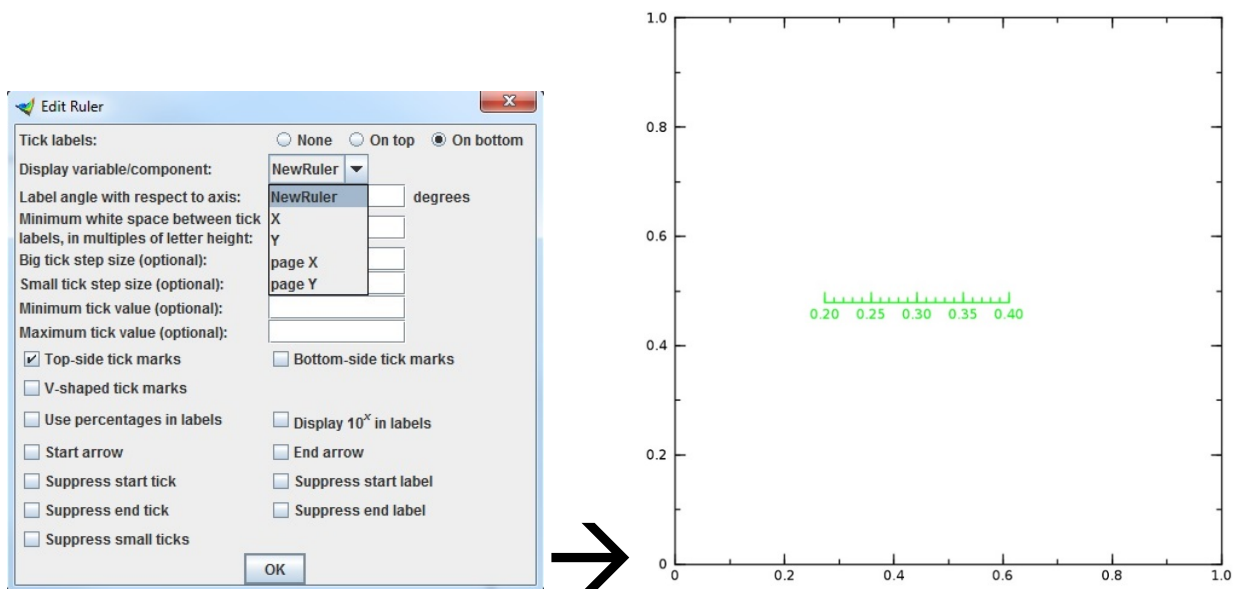

Appendix

NIST Data Center Digitizing Guidelines – SRD 31 (Phase Equilibria Diagrams)

Note: When special scaling considerations arise for label and line sizing, use your best judgment

- Match the .PED file name with the diagram's title (The diagram's title is located under Properties/Title in the PED editor while the .PED file name will contain the .PED file extension)
- Abbreviation for "**Liquid**" label = "**L**" or "**Liq.**"
- All temperature scales in **degrees Celsius**. Format: T °C (centered on axis, 1.4 font, aligned with the axis plane i.e. 90° from horizontal on T-x diagrams).
 - Exception: Temperature scales containing negative degree labels should not fill more than 1/4 of the total label count; otherwise, convert all to Kelvin scale
- All composition scales in **Mole Percentage**. Format: Mol % (centered on axis, 1.4 font, aligned with the axis plane)
 - Exception: Weight percent scales. Format: Wt % (centered, 1.4 font, aligned with axis plane)
- Label Size = **0.8** font, or **1.0** font
 - Axis Labels = **1.4** font
 - Composition Labels = **1.4** font (a single line break, centered over the scale's endpoints)
- Line Size = **0.0024** width
 - Solid lines = Experimental data (data points are not included in the database, however, your actual digitization vertexes should follow the experimental points)
 - Dashed lines = Calculated data
 - Dotted lines = Unsure/hypothetical border regions
- Dash/Dot Line Styles = Preference is for *most densely* packed dash/dot style
- Two-phase field Line Style = Tie (Fan) Lines
 - Fan Line = **0.0012** width
 - Fan Line Style = Solid
- Single-phase field Line Style = Railroad tracks
 - Railroad tracks = **0.0012** width
 - Railroad Line Style = The most dense, or the second most dense tracking (NOTE: The First and Last "track" on the railroad line should almost always bisect the points or lines at the railroad line's endpoints)
- "Dot" sizes = **0.8** font
- Tick-mark gap spacing: One small tick-mark between every labeled tick-mark
- Boxed temperature labels format: T = xxx°C (upper right corner, box is solid lines of 0.0024 width)