



(19) **United States**

(12) **Patent Application Publication**
Moffitt et al.

(10) **Pub. No.: US 2012/0203316 A1**

(43) **Pub. Date: Aug. 9, 2012**

(54) **LEADS WITH SEGMENTED ELECTRODES FOR ELECTRICAL STIMULATION OF PLANAR REGIONS AND METHODS OF MAKING AND USING**

Publication Classification

(51) **Int. Cl.**
A61N 1/05 (2006.01)
A61N 1/04 (2006.01)
(52) **U.S. Cl.** **607/116; 607/148**

(75) **Inventors:** **Michael Adam Moffitt**, Valencia, CA (US); **Anne Margaret Pianca**, Santa Monica, CA (US)

(57) **ABSTRACT**

(73) **Assignee:** **Boston Scientific Neuromodulation Corporation**, Valencia, CA (US)

One embodiment is a stimulation lead that includes a lead body having a longitudinal surface, a distal end, and a proximal end; and multiple electrodes disposed along the longitudinal surface of the lead body near the distal end of the lead body. The electrodes include multiple groups of segmented electrodes with each group of segmented electrodes having multiple segmented electrodes disposed at a same longitudinal position along the lead. For at least one first group of segmented electrodes, a first pair of the segmented electrodes in the first group are disposed on opposite sides of the lead body and are electrically ganged together by a conductor therebetween.

(21) **Appl. No.:** **13/368,733**

(22) **Filed:** **Feb. 8, 2012**

Related U.S. Application Data

(60) Provisional application No. 61/440,546, filed on Feb. 8, 2011.

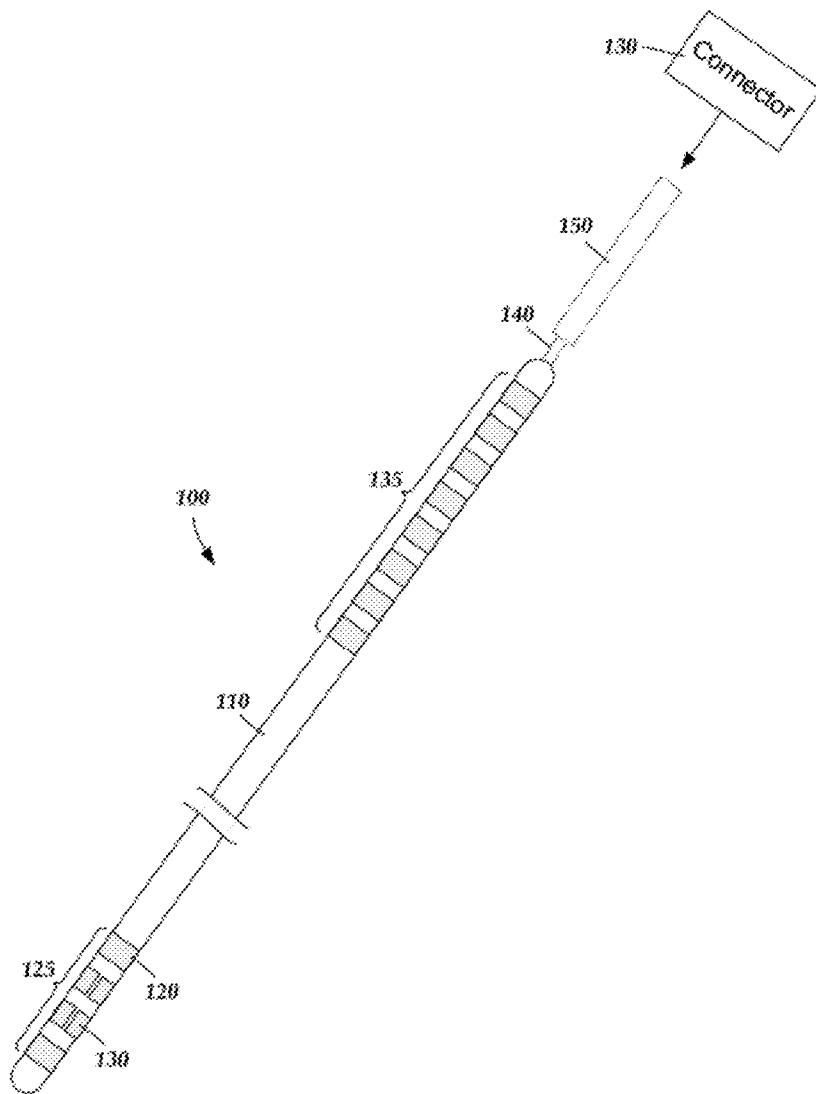

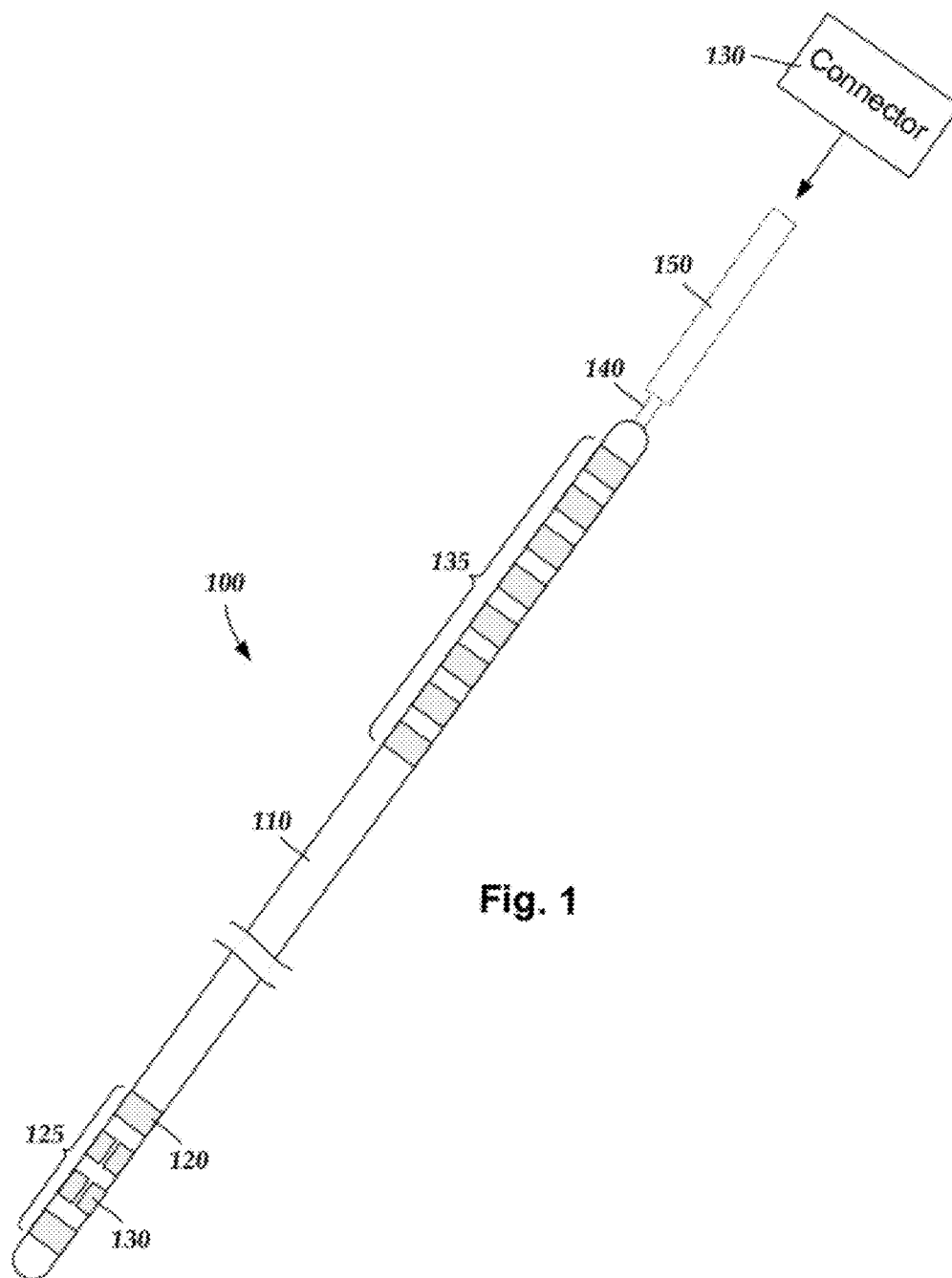

Fig. 1

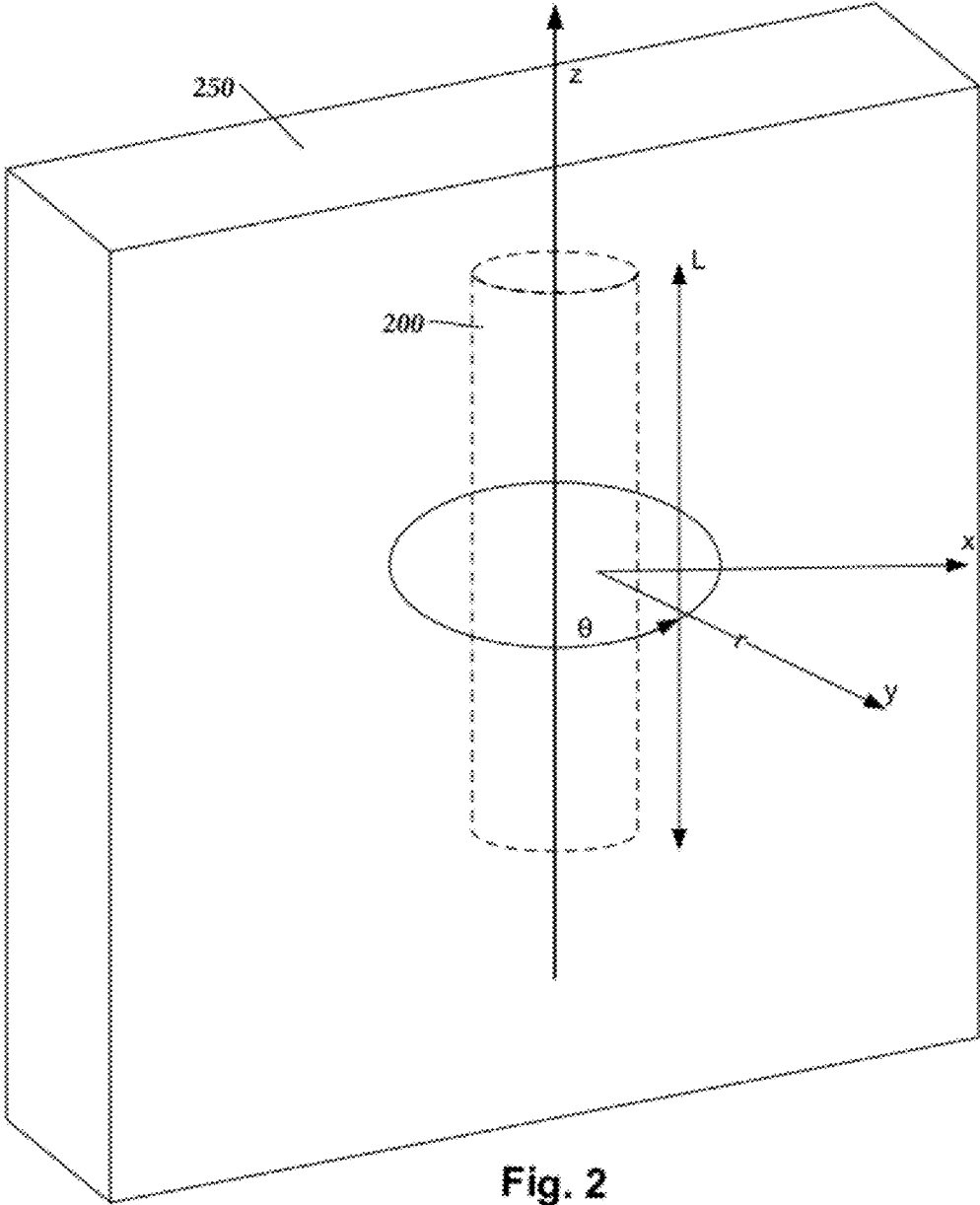
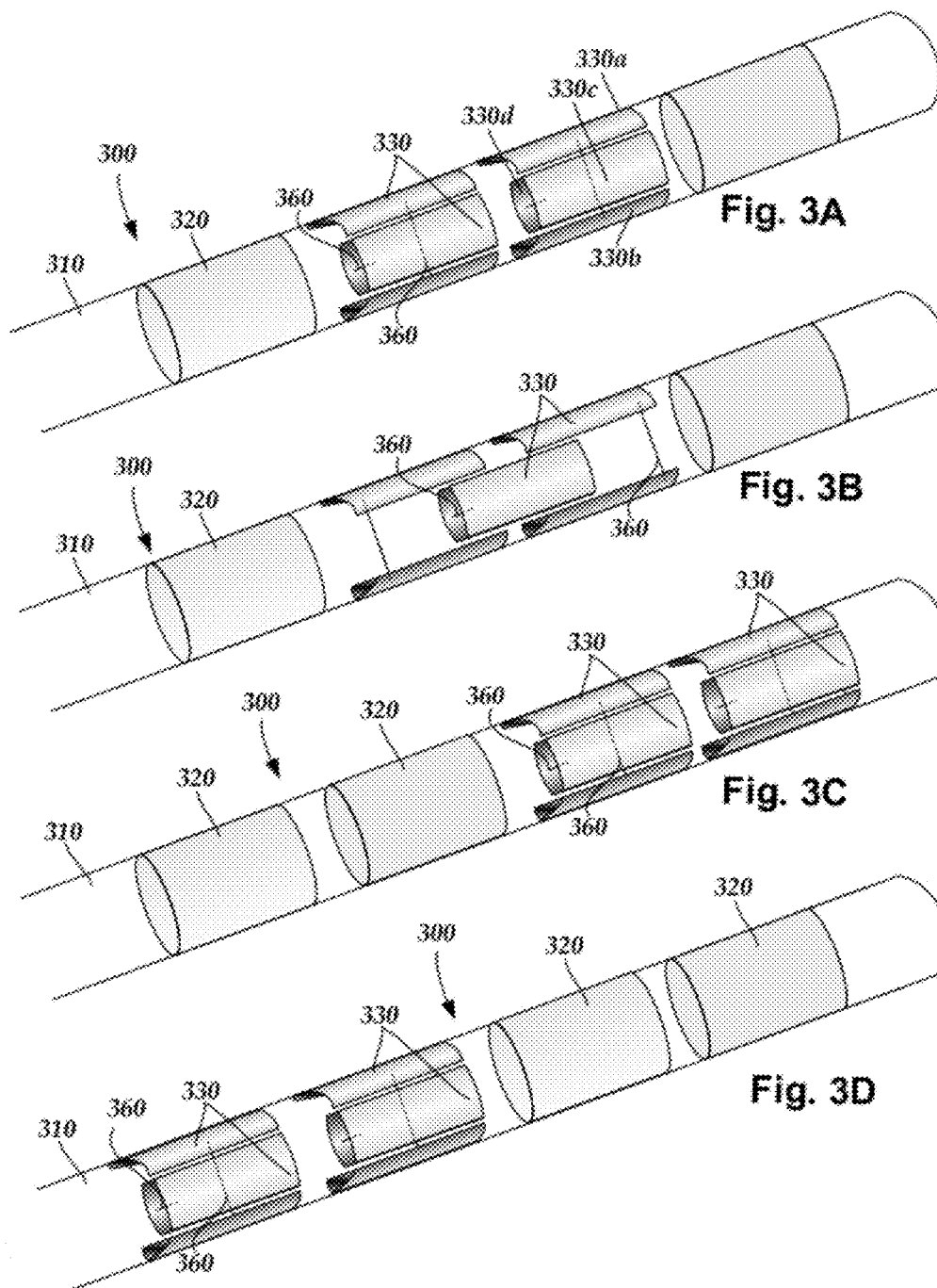

Fig. 2



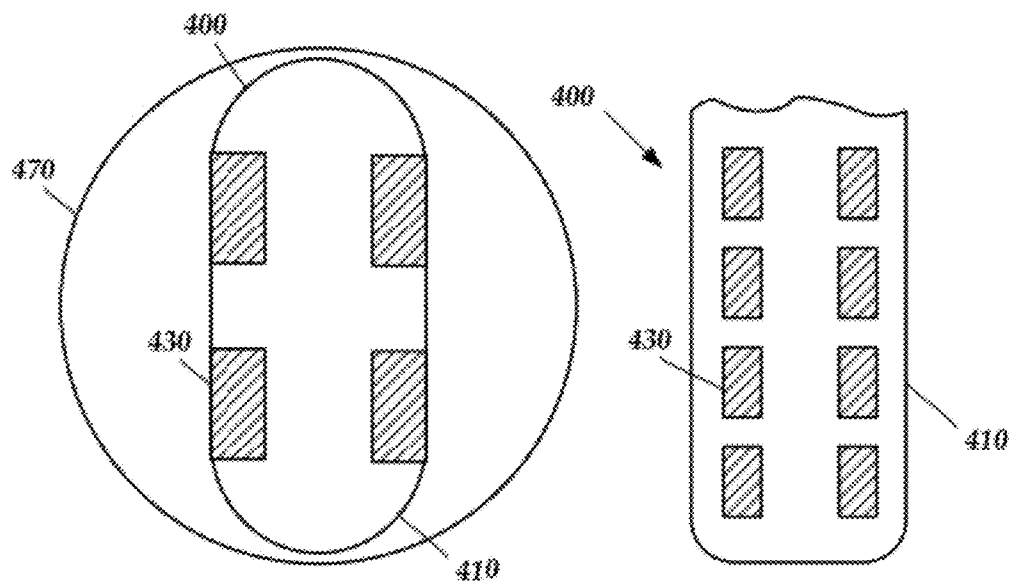

Fig. 4A

Fig. 4B

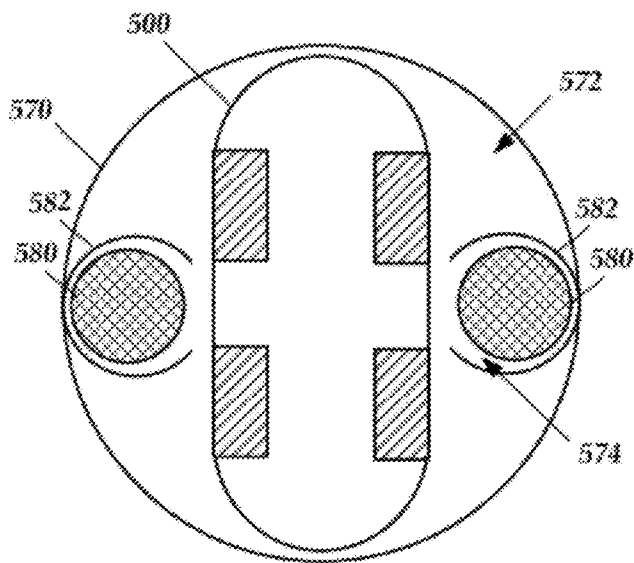

Fig. 5

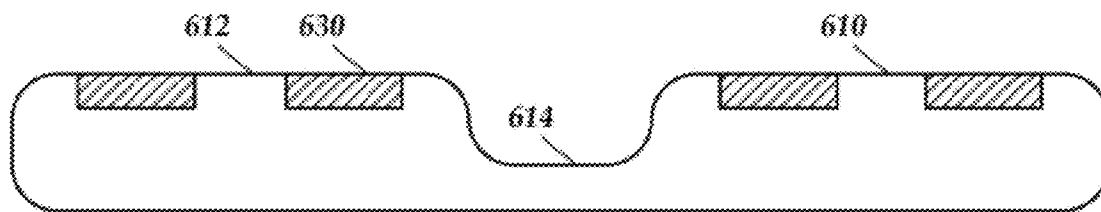

Fig. 6A

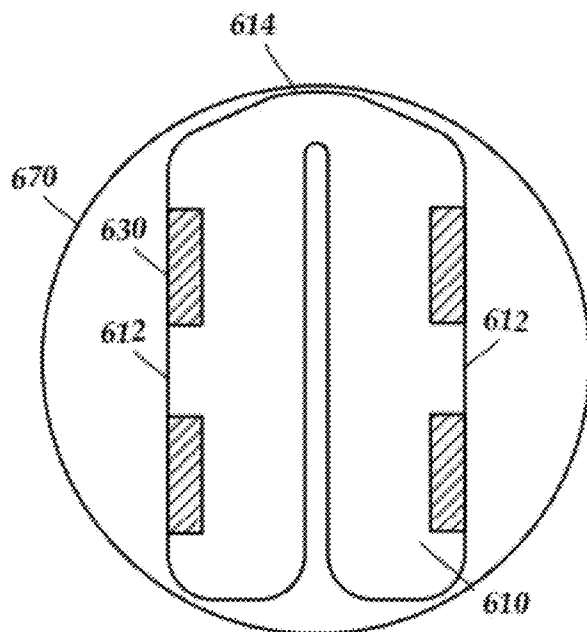

Fig. 6B

LEADS WITH SEGMENTED ELECTRODES FOR ELECTRICAL STIMULATION OF PLANAR REGIONS AND METHODS OF MAKING AND USING

CROSS-REFERENCE TO RELATED APPLICATIONS

[0001] This application claims the benefit under 35 U.S.C. §119(e) of U.S. Provisional Patent Application Ser. No. 61/440,546 filed on Feb. 8, 2011, which is incorporated herein by reference.

FIELD

[0002] The invention is directed to the area of electrical stimulation systems and methods of making and using the systems. The present invention is also directed to electrical stimulation leads with segmented electrodes that can be used for electrical stimulation of planar regions, as well as methods of making and using the segmented electrodes, leads, and electrical stimulation systems.

BACKGROUND

[0003] Electrical stimulation can be useful for treating a variety of conditions. Deep brain stimulation can be useful for treating, for example, Parkinson’s disease, dystonia, essential tremor, chronic pain, Huntington’s Disease, levodopa-induced dyskinesias and rigidity, bradykinesia, epilepsy and seizures, eating disorders, and mood disorders. Typically, a lead with a stimulating electrode at or near a tip of the lead provides the stimulation to target neurons in the brain. Magnetic resonance imaging (“MRI”) or computerized tomography (“CT”) scans can provide a starting point for determining where the stimulating electrode should be positioned to provide the desired stimulus to the target neurons.

[0004] After the lead is implanted into a patient’s brain, electrical stimulus current can be delivered through selected electrodes on the lead to stimulate target neurons in the brain. Typically, the electrodes are formed into rings disposed on a distal portion of the lead. The stimulus current projects from the ring electrodes equally in every direction. Because of the ring shape of these electrodes, the stimulus current cannot be directed to one or more specific positions around the ring electrode (e.g., on one or more sides, or points, around the lead). Consequently, undirected stimulation may result in unwanted stimulation of neighboring neural tissue, potentially resulting in undesired side effects.

BRIEF SUMMARY

[0005] One embodiment is a stimulation lead that includes a lead body having a longitudinal surface, a distal end, and a proximal end; and multiple electrodes disposed along the longitudinal surface of the lead body near the distal end of the lead body. The electrodes include multiple groups of segmented electrodes with each group of segmented electrodes having multiple segmented electrodes disposed at a same longitudinal position along the lead. For at least one first group of segmented electrodes, a first pair of the segmented electrodes in the first group are disposed on opposite sides of the lead body and are electrically ganged together by a conductor therebetween.

[0006] Another embodiment is a kit for implanting a stimulation lead into a patient. The kit includes a stimulation lead having a longitudinal surface, a distal end, and at least one

electrode disposed along the longitudinal surface of the stimulation lead near the distal end of the stimulation lead. A portion of the stimulation lead upon which the electrode(s) are disposed has a non-circular cross-sectional shape. The kit also includes at least one microelectrode lead having a distal end and at least one microelectrode disposed at the distal end of the microelectrode lead. The kit further includes an introducer defining a lumen configured and arranged to receive the stimulation lead. The introducer has at least one interior wall extending into the lumen and defining at least one microelectrode lumen that is configured and arranged to receive, and hold within the microelectrode lumen, one of the at least one microelectrode leads.

[0007] A further embodiment is a method for stimulating tissue that includes implanting a lead comprising a longitudinal surface, a distal end, a proximal end, two main portions disposed at the distal end of the lead, a bendable portion disposed between the two main portions, multiple electrodes disposed on surfaces of the two main portions of the lead, and multiple terminals disposed along the proximal end of the lead and electrically coupled to the electrodes. The bendable portion is bent so that the two main portions are disposed opposite each other and each electrode has an exposed surface through which electrical energy can be supplied to stimulate adjacent tissue when the stimulation lead is implanted. The method further includes retaining the lead in the patient with the bendable portion bent; and stimulating adjacent tissue using at least one of the electrodes.

BRIEF DESCRIPTION OF THE DRAWINGS

[0008] Non-limiting and non-exhaustive embodiments of the present invention are described with reference to the following drawings. In the drawings, like reference numerals refer to like parts throughout the various figures unless otherwise specified.

[0009] For a better understanding of the present invention, reference will be made to the following Detailed Description, which is to be read in association with the accompanying drawings, wherein:

[0010] FIG. 1 is a schematic side view of one embodiment of a device for brain stimulation, according to the invention;

[0011] FIG. 2 is a schematic diagram of radial current steering along various electrode levels along the length of a lead, according to the invention;

[0012] FIG. 3A is a perspective view of an embodiment of a portion of a lead having a plurality of segmented electrodes with selected electrodes electrically ganged, according to the invention;

[0013] FIG. 3B is a perspective view of a second embodiment of a portion of a lead having a plurality of segmented electrodes with selected electrodes electrically ganged, according to the invention;

[0014] FIG. 3C is a perspective view of a third embodiment of a portion of a lead having a plurality of segmented electrodes with selected electrodes electrically ganged, according to the invention;

[0015] FIG. 3D is a perspective view of a fourth embodiment of a portion of a lead having a plurality of segmented electrodes with selected electrodes electrically ganged, according to the invention;

[0016] FIG. 4A is a schematic cross-sectional view of one embodiment of a lead with a non-circular cross-sectional shape that can be implanted using a percutaneous introducer, according to the invention;

[0017] FIG. 4B is a schematic top plan view of a portion of one embodiment of the lead of FIG. 4A with an example of an electrode arrangement, according to the invention;

[0018] FIG. 5 is a schematic cross-sectional view of one embodiment of a lead disposed in an introducer that also contains microelectrode lumens for receiving microelectrode leads, according to the invention;

[0019] FIG. 6A is a schematic cross-sectional view of one embodiment of a lead having two main portions, each containing electrodes, separated by a bendable portion, according to the invention; and

[0020] FIG. 6B is a schematic cross-sectional view of one embodiment of the lead of FIG. 6A with the bendable portion bent and the lead disposed in a percutaneous introducer, according to the invention.

DETAILED DESCRIPTION

[0021] The invention is directed to the area of electrical stimulation systems and methods of making and using the systems. The present invention is also directed to electrical stimulation leads with segmented electrodes that can be used for electrical stimulation of planar regions, as well as methods of making and using the segmented electrodes, leads, and electrical stimulation systems.

[0022] A lead for deep brain stimulation may include stimulation electrodes, recording electrodes, or a combination of both. At least some of the stimulation electrodes, recording electrodes, or both are provided in the form of segmented electrodes that extend only partially around the circumference of the lead. These segmented electrodes can be provided in sets of electrodes, with each set having electrodes radially distributed about the lead at a particular longitudinal position.

[0023] A practitioner may determine the position of the target neurons using the recording electrode(s) and then position the stimulation electrode(s) accordingly without removal of a recording lead and insertion of a stimulation lead. In some embodiments, the same electrodes can be used for both recording and stimulation. In some embodiments, separate leads can be used; one with recording electrodes which identify target neurons, and a second lead with stimulation electrodes that replaces the first after target neuron identification. A lead may include recording electrodes spaced around the circumference of the lead to more precisely determine the position of the target neurons. In at least some embodiments, the lead is rotatable so that the stimulation electrodes can be aligned with the target neurons after the neurons have been located using the recording electrodes. For illustrative purposes, the leads are described herein relative to use for deep brain stimulation, but it will be understood that any of the leads can be used for applications other than deep brain stimulation, including spinal cord stimulation and stimulation of other nerves and tissues.

[0024] Deep brain stimulation devices and leads are described in, for example, U.S. Pat. No. 7,809,446 (“Devices and Methods For Brain Stimulation”), U.S. Patent Application Publication No. 2010/0076535 A1 (“Leads With Non-Circular-Shaped Distal Ends For Brain Stimulation Systems and Methods of Making and Using”), U.S. Patent Application Publication 2007/0150036 A1 (“Stimulator Leads and Methods For Lead Fabrication”), U.S. patent application Ser. No. 12/177,823 (“Lead With Transition and Methods of Manufacture and Use”), U.S. Patent Application Publication No. 2009/0276021 A1 (“Electrodes For Stimulation Leads and

Methods of Manufacture and Use”), U.S. Patent Application Ser. No. 61/170,037 (“Deep Brain Stimulation Current Steering with Split Electrodes”), U.S. Patent Application Ser. No. 61/022,953, U.S. Patent Application Ser. No. 61/316,759, U.S. Patent Application Publication No. 2009/0187222 A1, and U.S. Patent Application Ser. No. 61/426,784. Each of these references is incorporated herein by reference.

[0025] FIG. 1 illustrates one embodiment of a device 100 for brain stimulation. The device includes a lead 110, a plurality of electrodes 125 disposed at least partially about a circumference of the lead 110, a plurality of terminals 135, a connector 130 for connection of the electrodes to a control unit, and a stylet 140 for assisting in insertion and positioning of the lead in the patient’s brain. The stylet 140 can be made of a rigid material. Examples of suitable materials for the stylet include, but are not limited to, tungsten, stainless steel, and plastic. The stylet 140 may have a handle 150 to assist insertion into the lead 110, as well as rotation of the stylet 140 and lead 110. The connector 130 fits over a proximal end of the lead 110, preferably after removal of the stylet 140.

[0026] The control unit (not shown) is typically an implantable pulse generator that can be implanted into a patient’s body, for example, below the patient’s clavicle area. The pulse generator can have eight stimulation channels which may be independently programmable to control the magnitude of the current stimulus from each channel. In some cases the pulse generator may have more or fewer than eight stimulation channels (e.g., 4-, 6-, 16-, 32-, or more stimulation channels). The control unit may have one, two, three, four, or more connector ports, for receiving the plurality of terminals 135 at the proximal end of the lead 110.

[0027] In one example of operation, access to the desired position in the brain can be accomplished by drilling a hole in the patient’s skull or cranium with a cranial drill (commonly referred to as a burr), and coagulating and incising the dura mater, or brain covering. The lead 110 can be inserted into the cranium and brain tissue with the assistance of the stylet 140. The lead 110 can be guided to the target location within the brain using, for example, a stereotactic frame and a microdrive motor system. In some embodiments, the microdrive motor system can be fully or partially automatic. The microdrive motor system may be configured to perform one or more of the following actions (alone or in combination): insert the lead 110, retract the lead 110, or rotate the lead 110.

[0028] In some embodiments, measurement devices coupled to the muscles or other tissues stimulated by the target neurons, or a unit responsive to the patient or clinician, can be coupled to the control unit or microdrive motor system. The measurement device, user, or clinician can indicate a response by the target muscles or other tissues to the stimulation or recording electrode(s) to further identify the target neurons and facilitate positioning of the stimulation electrode(s). For example, if the target neurons are directed to a muscle experiencing tremors, a measurement device can be used to observe the muscle and indicate changes in tremor frequency or amplitude in response to stimulation of neurons. Alternatively, the patient or clinician may observe the muscle and provide feedback.

[0029] The lead 110 for deep brain stimulation can include stimulation electrodes, recording electrodes, or both. In at least some embodiments, the lead 110 is rotatable so that the stimulation electrodes can be aligned with the target neurons after the neurons have been located using the recording electrodes.

[0030] Stimulation electrodes may be disposed on the circumference of the lead **110** to stimulate the target neurons. Stimulation electrodes may be ring-shaped so that current projects from each electrode equally in every direction from the position of the electrode along a length of the lead **110**. Ring electrodes, however, typically do not enable stimulus current to be directed to only one side of the lead. Segmented electrodes, however, can be used to direct stimulus current to one side, or even a portion of one side, of the lead. When segmented electrodes are used in conjunction with an implantable pulse generator that delivers constant current stimulus, current steering can be achieved to more precisely deliver the stimulus to a position around an axis of the lead (i.e., radial positioning around the axis of the lead).

[0031] To achieve current steering, segmented electrodes can be utilized in addition to, or as an alternative to, ring electrodes. Though the following description discusses stimulation electrodes, it will be understood that all configurations of the stimulation electrodes discussed may be utilized in arranging recording electrodes as well.

[0032] The lead **100** includes a lead body **110**, one or more optional ring electrodes **120**, and a plurality of sets of segmented electrodes **130**. The lead body **110** can be formed of a biocompatible, non-conducting material such as, for example, a polymeric material. Suitable polymeric materials include, but are not limited to, silicone, polyurethane, polyurea, polyurethane-urea, polyethylene, or the like. Once implanted in the body, the lead **100** may be in contact with body tissue for extended periods of time. In at least some embodiments, the lead **100** has a cross-sectional diameter of no more than 1.5 mm and may be in the range of 1 to 1.5 mm. In at least some embodiments, the lead **100** has a length of at least 10 cm and the length of the lead **100** may be in the range of 25 to 70 cm.

[0033] The electrodes may be made using a metal, alloy, conductive oxide, or any other suitable conductive biocompatible material. Examples of suitable materials include, but are not limited to, platinum, platinum iridium alloy, iridium, titanium, tungsten, palladium, palladium rhodium, or the like. Preferably, the electrodes are made of a material that is biocompatible and does not substantially corrode under expected operating conditions in the operating environment for the expected duration of use.

[0034] Each of the electrodes can either be used or unused (OFF). When the electrode is used, the electrode can be used as an anode or cathode and carry anodic or cathodic current. In some instances, an electrode might be an anode for a period of time and a cathode for a period of time.

[0035] Stimulation electrodes in the form of ring electrodes **120** may be disposed on any part of the lead body **110**, usually near a distal end of the lead **100**. In FIG. 1, the lead **100** includes two ring electrodes **120**. Any number of ring electrodes **120** may be disposed along the length of the lead body **110** including, for example, one, two three, four, five, six, seven, eight, nine, ten, eleven, twelve, thirteen, fourteen, fifteen, sixteen or more ring electrodes **120**. It will be understood that any number of ring electrodes may be disposed along the length of the lead body **110**. In some embodiments, the ring electrodes **120** are substantially cylindrical and wrap around the entire circumference of the lead body **110**. In some embodiments, the outer diameters of the ring electrodes **120** are substantially equal to the outer diameter of the lead body **110**. The length of the ring electrodes **120** may vary according to the desired treatment and the location of the target neurons.

In some embodiments the length of the ring electrodes **120** are less than or equal to the diameters of the ring electrodes **120**. In other embodiments, the lengths of the ring electrodes **120** are greater than the diameters of the ring electrodes **120**.

[0036] Deep brain stimulation leads may include one or more sets of segmented electrodes. Segmented electrodes may provide for superior current steering than ring electrodes because target structures in deep brain stimulation are not typically symmetric about the axis of the distal electrode array. Instead, a target may be located on one side of a plane running through the axis of the lead. Through the use of a radially segmented electrode array ("RSEA"), current steering can be performed not only along a length of the lead but also around a circumference of the lead. This provides precise three-dimensional targeting and delivery of the current stimulus to neural target tissue, while potentially avoiding stimulation of other tissue.

[0037] In FIG. 1, the lead **100** is shown having a plurality of segmented electrodes **130**. Any number of segmented electrodes **130** may be disposed on the lead body **110** including, for example, one, two three, four, five, six, seven, eight, nine, ten, eleven, twelve, thirteen, fourteen, fifteen, sixteen or more segmented electrodes **130**. It will be understood that any number of segmented electrodes **130** may be disposed along the length of the lead body **110**.

[0038] The segmented electrodes **130** may be grouped into sets of segmented electrodes, where each set is disposed around a circumference of the lead **100** at a particular longitudinal portion of the lead **100**. The lead **100** may have any number segmented electrodes **130** in a given set of segmented electrodes. The lead **100** may have one, two, three, four, five, six, seven, eight, or more segmented electrodes **130** in a given set. In at least some embodiments, each set of segmented electrodes **130** of the lead **100** contains the same number of segmented electrodes **130**. The segmented electrodes **130** disposed on the lead **100** may include a different number of electrodes than at least one other set of segmented electrodes **130** disposed on the lead **100**.

[0039] The segmented electrodes **130** may vary in size and shape. In some embodiments, the segmented electrodes **130** are all of the same size, shape, diameter, width or area or any combination thereof. In some embodiments, the segmented electrodes **130** of each circumferential set (or even all segmented electrodes disposed on the lead **100**) may be identical in size and shape.

[0040] Each set of segmented electrodes **130** may be disposed around the circumference of the lead body **110** to form a substantially cylindrical shape around the lead body **110**. The spacing between individual electrodes of a given set of the segmented electrodes may be the same, or different from, the spacing between individual electrodes of another set of segmented electrodes on the lead **100**. In at least some embodiments, equal spaces, gaps or cutouts are disposed between each segmented electrode **130** around the circumference of the lead body **110**. In other embodiments, the spaces, gaps or cutouts between the segmented electrodes **130** may differ in size or shape. In other embodiments, the spaces, gaps, or cutouts between segmented electrodes **130** may be uniform for a particular set of the segmented electrodes **130**, or for all sets of the segmented electrodes **130**. The sets of segmented electrodes **130** may be positioned in irregular or regular intervals along a length the lead body **110**.

[0041] Conductor wires that attach to the ring electrodes **120** or segmented electrodes **130** extend along the lead body

110. These conductor wires may extend through the material of the lead **100** or along one or more lumens defined by the lead **100**, or both. The conductor wires are presented at a connector (via terminals) for coupling of the electrodes **120**, **130** to a control unit (not shown).

[0042] When the lead **100** includes both ring electrodes **120** and segmented electrodes **130**, the ring electrodes **120** and the segmented electrodes **130** may be arranged in any suitable configuration. For example, when the lead **100** includes two sets of ring electrodes **120** and two sets of segmented electrodes **130**, the ring electrodes **120** can flank the two sets of segmented electrodes **130** (see e.g., FIG. 1). Alternately, the two sets of ring electrodes **120** can be disposed proximal to the two sets of segmented electrodes **130** (see e.g., FIG. 3C), or the two sets of ring electrodes **120** can be disposed distal to the two sets of segmented electrodes **130** (see e.g., FIG. 3D). It will be understood that other configurations are possible as well (e.g., alternating ring and segmented electrodes, or the like).

[0043] By varying the location of the segmented electrodes **130**, different coverage of the target neurons may be selected. For example, the electrode arrangement of FIG. 3C may be useful if the physician anticipates that the neural target will be closer to a distal tip of the lead body **110**, while the electrode arrangement of FIG. 3D may be useful if the physician anticipates that the neural target will be closer to a proximal end of the lead body **110**.

[0044] Any combination of ring electrodes **120** and segmented electrodes **130** may be disposed on the lead **100**. For example, the lead may include a first ring electrode **120**, two sets of segmented electrodes; each set formed of four segmented electrodes **130**, and a final ring electrode **120** at the end of the lead. This configuration may simply be referred to as a 1-4-4-1 configuration. It may be useful to refer to the electrodes with this shorthand notation. Thus, the embodiment of FIG. 3C may be referred to as a 1-1-4-4 configuration, while the embodiment of FIG. 3D may be referred to as a 4-4-1-1 configuration. Other electrode configurations include, for example, a 2-2-2-2 configuration, where four sets of segmented electrodes are disposed on the lead, and a 4-4 configuration, where two sets of segmented electrodes, each having four segmented electrodes **130** are disposed on the lead. In some embodiments, the lead includes 16 electrodes. Possible configurations for a 16-electrode lead include, but are not limited to 4-4-4-4; 8-8; 3-3-3-3-1 (and all rearrangements of this configuration); and 2-2-2-2-2-2-2-2.

[0045] FIG. 2 is a schematic diagram to illustrate radial current steering along various electrode levels along the length of the lead **200**. While conventional lead configurations with ring electrodes are only able to steer current along the length of the lead (the z-axis), the segmented electrode configuration is capable of steering current in the x-axis, y-axis as well as the z-axis. Thus, the centroid of stimulation may be steered in any direction in the three-dimensional space surrounding the lead **200**. In some embodiments, the radial distance, r , and the angle θ around the circumference of the lead **200** may be dictated by the percentage of anodic current (recognizing that stimulation predominantly occurs near the cathode, although strong anodes may cause stimulation as well) introduced to each electrode. In at least some embodiments, the configuration of anodes and cathodes along the segmented electrodes allows the centroid of stimulation to be shifted to a variety of different locations along the lead **200**.

[0046] As can be appreciated from FIG. 2, the centroid of stimulation can be shifted at each level along the length of the lead **200**. The use of multiple sets of segmented electrodes at different levels along the length of the lead allows for three-dimensional current steering. In some embodiments, the sets of segmented electrodes are shifted collectively (i.e., the centroid of stimulation is similar at each level along the length of the lead). In at least some other embodiments, each set of segmented electrodes is controlled independently. Each set of segmented electrodes may contain two, three, four, five, six, seven, eight or more segmented electrodes. It will be understood that different stimulation profiles may be produced by varying the number of segmented electrodes at each level. For example, when each set of segmented electrodes includes only two segmented electrodes, uniformly distributed gaps (inability to stimulate selectively) may be formed in the stimulation profile. In some embodiments, at least three segmented electrodes **230** in a set are utilized to allow for true 360° selectivity.

[0047] As previously indicated, the foregoing configurations may also be used while utilizing recording electrodes. In some embodiments, measurement devices coupled to the muscles or other tissues stimulated by the target neurons or a unit responsive to the patient or clinician can be coupled to the control unit or microdrive motor system. The measurement device, user, or clinician can indicate a response by the target muscles or other tissues to the stimulation or recording electrodes to further identify the target neurons and facilitate positioning of the stimulation electrodes. For example, if the target neurons are directed to a muscle experiencing tremors, a measurement device can be used to observe the muscle and indicate changes in tremor frequency or amplitude in response to stimulation of neurons. Alternatively, the patient or clinician may observe the muscle and provide feedback.

[0048] The reliability and durability of the lead will depend heavily on the design and method of manufacture. Fabrication techniques discussed below provide methods that can produce manufacturable and reliable leads.

[0049] Returning to FIG. 1, when the lead **100** includes a plurality of sets of segmented electrodes **130**, it may be desirable to form the lead **100** such that corresponding electrodes of different sets of segmented electrodes **130** are radially aligned with one another along the length of the lead **100** (see e.g., the segmented electrodes **130** shown in FIG. 1). Radial alignment between corresponding electrodes of different sets of segmented electrodes **130** along the length of the lead **100** may reduce uncertainty as to the location or orientation between corresponding segmented electrodes of different sets of segmented electrodes. Accordingly, it may be beneficial to form electrode arrays such that corresponding electrodes of different sets of segmented electrodes along the length of the lead **100** are radially aligned with one another and do not radially shift in relation to one another during manufacturing of the lead **100**.

[0050] In other embodiments, individual electrodes in the two sets of segmented electrodes **130** are staggered relative to one another along the length of the lead body **110**. In some cases, the staggered positioning of corresponding electrodes of different sets of segmented electrodes along the length of the lead **100** may be designed for a specific application.

[0051] Segmented electrodes can be used to tailor the stimulation region so that, instead of stimulating tissue around the circumference of the lead as would be achieved using a ring electrode, the stimulation region can be direc-

tionally targeted. In some instances, it is desirable to target a parallelepiped (or slab) region **250** that contains the electrodes of the lead **200**, as illustrated in FIG. 2. One arrangement for directing a stimulation field into a parallelepiped region uses segmented electrodes disposed on opposite sides of a lead.

[0052] FIGS. 3A-3D illustrate leads **300** with segmented electrodes **330**, optional ring electrodes **320**, and a lead body **310**. The groups of segmented electrodes **330** include either two (FIG. 3B) or four (FIGS. 3A, 3C, and 3D) segmented electrodes. It will be recognized that other groups of segmented electrodes with an even number of electrodes in the group can also be used. In these embodiments, segmented electrodes on opposite sides of the lead are ganged (i.e., electrically coupled) together, as illustrated schematically by the lines **360**.

[0053] One arrangement for ganging two segmented electrodes together which includes coupling the two electrodes (for example, electrodes **330a** and **330b**) using a conductor (represented by line **360**) that passes through the lead body. This conductor (represented by line **360**) can be coupled to another conductor (not shown) that passes through the lead body to the proximal end of the lead to provide for connection to a terminal or contact at the proximal end of the lead. Alternatively, one electrode (for example, electrode **330a**) is electrically coupled to a conductor (not shown) that passes through the lead body to the proximal end of the lead to provide for connection to a terminal or contact at the proximal end of the lead and the other electrode (for example, electrode **330b**) is coupled to the first electrode by the conductor represented by line **360**. This conductor might be a wire or may be a thin, flat conductor.

[0054] In operation, stimulation current is applied through the ganged segmented electrodes (for example, electrodes **330a** and **330b**). For example, the ganged segmented electrodes can operate as cathodes. In some embodiments, other ganged electrodes (for example, electrodes **330c** and **330d**) may be assigned the opposite polarity (for example, as anodes) which may further direct the stimulation field into the desired parallelepiped region.

[0055] As illustrated in FIGS. 3A, 3C, and 3D, multiple pairs of ganged segmented electrodes **330** can be provided in each group of segmented electrodes. The pairs of ganged segmented electrodes **330** are radially offset from each other. For example, two pairs may be radially offset by an angle in the range of 75 to 115 degrees or by an angle in the range of 80 to 110 degrees or be an angle of 90 degrees.

[0056] As illustrated in FIG. 3B, the pairs of ganged segmented electrodes can be longitudinally staggered with respect to each other. As illustrated in FIG. 3B, the staggered pairs of ganged segmented electrodes may include electrode portions that are at a same longitudinal position (i.e., the two pairs overlap longitudinally—but not radially). In other embodiments, the electrodes of the staggered pairs do not overlap longitudinally (i.e., no portions of the electrodes of the two pairs have the same longitudinal position on the lead).

[0057] Any other suitable arrangements of segmented electrodes (and pairs of ganged segmented electrodes) can be used. As an example, arrangements in which pairs of segmented electrodes are arranged helically with respect to each other. One embodiment includes a double helix with the electrodes at each longitudinal position along the two helices ganged together.

[0058] As an alternative to ganging segmented electrodes together using conductors, the segmented electrodes (or a subset of segmented electrodes) can be coupled to a multiplexer (which is preferably disposed in the lead near the electrodes) or to controllable switches (which are preferably disposed in the lead near the electrodes). The multiplexer or controllable switches can be used to electrically gang segmented electrodes together, but can also be used to change which electrodes are ganged together, if desired.

[0059] Other lead configurations can also be used. For example, FIGS. 4A and 4B illustrate portions of a lead **400** with a lead body **410** having a non-circular cross-section and including two elongated surfaces upon which electrodes **430** are disposed. This lead **400** is sized so that it can be implanted percutaneously using an introducer **470** such as a percutaneous needle or cannula.

[0060] The lead body **410** can have any suitable non-circular cross-sectional shape including, but not limited to, oval, rectangular, square, or rectangular/square with rounded corners (as illustrated in FIG. 4), or the like. In some embodiments, the non-circular cross-sectional shape of the lead extends the entire length of the lead. In other embodiments, the non-circular cross-sectional shape of the lead only extends a portion (for example, a portion including the region near the distal end upon which the electrodes are disposed) of the length of the lead with the remainder of the lead having a circular cross-sectional shape (for example, a portion including the proximal end of the lead).

[0061] The lead body **410** has two opposing surfaces upon which electrodes **430** can be disposed. These surfaces may be flat or curved. The electrodes are coupled to terminals (not shown) on the proximal end of the lead by conductors (not shown) that extend along the length of the lead.

[0062] The electrodes can be formed using any biocompatible conductive material. Examples of suitable materials include metals, alloys, conductive polymers, conductive carbon, and the like, as well as combinations thereof. In at least some embodiments, one or more of the electrodes are formed from one or more of: platinum, platinum iridium, palladium, titanium nitride, or rhenium.

[0063] The electrodes **430** can be disposed in an array on each of the surfaces of the lead, as illustrated in FIG. 4B. The number of electrodes **430** in the array of electrodes on a particular surface of the lead may vary. For example, there can be two, three, four, five, six, seven, eight, nine, ten, eleven, twelve, thirteen, fourteen, fifteen, sixteen, or more electrodes. As will be recognized, other numbers of electrodes may also be used. The electrodes **140** can be formed in any suitable shape including, for example, round, oval, triangular, rectangular, pentagonal, hexagonal, heptagonal, octagonal, or the like. The electrodes **430** of an array can be arranged in any arrangement including arrangements with in one or more columns, one or more rows, or both rows and columns (as illustrated in FIG. 4B). The electrodes **430** in a row or column may be aligned with an adjacent row or column or may be staggered with respect to an adjacent row or column. There may be an array of electrodes **430** on two opposing sides of lead **400**, as illustrated in FIG. 4A. The arrays on the two opposing sides can be the same or different.

[0064] The electrodes **430** are typically disposed in, or separated by, a non-conductive, biocompatible material of the lead body **410** including, for example, silicone, polyurethane, and the like or combinations thereof. The lead body **410** may be formed in the desired shape by any process including, for

example, molding (including injection molding), casting, and the like. Electrodes and connecting wires can be disposed onto or within the lead body either prior to or subsequent to a molding or casting process.

[0065] In some embodiments, electrodes **430** on opposite sides (and, preferably, directly opposite each other) of the lead body **410** can be ganged together in a manner similar to that illustrated for the embodiments of FIGS. 3A-3D. In some embodiments, electrodes **430** on the same side of the lead body **410** (for example, electrodes in a row or column) can be ganged together.

[0066] A lead with a lead body having a non-circular cross-sectional shape and electrodes disposed thereon can be formed using a suitable technique including forming a lead body around electrodes disposed in two sides of a mold. In at least some instances, it may be easier or more economical to form electrodes on one side of a lead body. FIGS. 6A and 6B illustrate one method for forming a lead body **610** having a non-circular cross-sectional shape and electrodes **630** disposed on opposing sides of the lead body. As illustrated in FIG. 6A, a lead body **610** with electrodes **630** disposed on one side of the lead body is formed. For example, the electrodes **630** can be attached to conductors (not shown) which can extend along the lead to terminals or contact on a distal end of the lead. These electrodes **630** can be placed in a mold and then the lead body **610** molded around the electrodes **630** leaving a surface of each electrode exposed.

[0067] In these embodiments, the lead body **610** includes two main portions **612** divided by a bendable portion **614**. The electrodes are disposed on the two main portions **612**. In at least some embodiments, the bendable portion **614** has a thickness that is substantially less than a thickness of the two main portions. In some embodiments, the bendable portion **612** may include one or more hinges, one or more holes, one or more reduced-thickness portion, or any other suitable structure that facilitates bending or folding of the bendable portion.

[0068] In forming the lead with electrodes on opposing sides, the bendable portion **614** is bent so that the two main portions **612** are disposed opposite each other, as illustrated in FIG. 6B. This lead body **610** can be inserted into an introducer **670**. In some embodiments, the bendable portion **614** contains material that retains the bend once bent. In other embodiments, the bendable portion **614** is resilient and may spring back to its original shape or some intermediate position. Optionally, one or more fasteners (e.g., straps, hooks, and the like), sutures disposed around the lead body, or adhesive may be provided to retain the lead body **610** in the bent shape. In other embodiments, the lead body **610** retains the bent shape once implanted due to the presence of adjacent tissue.

[0069] When implanting a lead, particularly in the brain, it can be useful to provide a recording electrode that can be used to identify the tissue that is to be stimulated. In many conventional procedures, a recording electrode lead is inserted into an introducer and the introducer is inserted into the patient. The introducer is then moved through the tissue using the recording electrode to identify which tissue is to be stimulated. Once the desired tissue is identified, the recording electrode lead is removed from the introducer and a stimulating electrode lead is inserted. This conventional procedure can take additional time for removal and insertion of multiple leads. Moreover, the introducer may inadvertently move during removal of the recording electrode lead and the insertion

of the stimulating electrode lead which may result in the stimulating electrode lead being no longer aligned with the desired tissue.

[0070] A system can be provided that addresses this issue by providing an introducer and lead that can be used simultaneously with a microelectrode lead. FIG. 5 illustrates one embodiment of such a system with an introducer **570** (e.g., a cannula or a needle) defining an introducer lumen **572** into which a stimulation lead **500** (which can correspond to the lead **400** of FIGS. 4A and 4B) can be inserted. Within the introducer lumen **572**, one or more microelectrode lumens **574** are formed using one or more walls **582**. FIG. 5 illustrates two microelectrode lumens, but in other embodiments only one microelectrode lumen is provided. A microelectrode lead **580** can be inserted with each microelectrode lumen **574** formed within the introducer **570**. The microelectrode lead **580** includes a microelectrode at a tip of the microelectrode lead **580** which can be used as a recording electrode to identify tissue to be stimulated. The microelectrode lead **580** may be, for example, a guidewire or other suitable lead structure.

[0071] The walls **582** which form the microelectrode lumens **574** can be cylindrical or any other suitable shape. The walls **582** surround the entire lumen (e.g., have a circular cross-section) or may include openings (for example, have a C-shape in cross-section, as illustrated in FIG. 5). In some instances, a portion of the wall of the introducer may form part of the wall **582** of the microelectrode lumens **574**. The walls **582** may extend the entire length of the introducer **570** or may only extend partway along the introducer, for example, partway from the distal end or the proximal end or a combination thereof.

[0072] The arrangement illustrated in FIG. 5 allows for the introducer **570** to contain both the microelectrode lead(s) **580** and the stimulation lead **500** simultaneously. In some embodiments, both the microelectrode lead(s) **580** and stimulation lead are inserted into the introducer prior to insertion of the introducer into the patient. In other embodiments, the microelectrode lead(s) may be inserted into the introducer prior to, or after, insertion of the introducer into the patient and then the microelectrode lead(s) are used to identify the tissue to be stimulated. Later, the stimulation lead may be inserted into the introducer with the microelectrode lead(s) remaining in the introducer. The microelectrode lead(s) can be used to verify that the stimulation lead is properly positioned after it insertion into the introducer in the patient.

[0073] The above specification, examples, and data provide a description of the manufacture and use of the composition of the invention. Since many embodiments of the invention can be made without departing from the spirit and scope of the invention, the invention also resides in the claims hereinafter appended.

What is claimed as new and desired to be protected by Letters Patent of the United States is:

1. A stimulation lead, comprising:
 - a lead body comprising a longitudinal surface, a distal end, and a proximal end; and
 - a plurality of electrodes disposed along the longitudinal surface of the lead body near the distal end of the lead body, the plurality of electrodes comprising a plurality of groups of segmented electrodes, each group of segmented electrodes comprising a plurality of segmented electrodes disposed at a same longitudinal position along the lead, wherein, for at least one first group of the plurality of groups of segmented electrodes, a first pair

of the segmented electrodes in the first group are disposed on opposite sides of the lead body and are electrically ganged together by a conductor therebetween.

2. The stimulation lead of claim 1, wherein the first group consists of the first pair of segmented electrodes.

3. The stimulation lead of claim 1, wherein the first group comprises at least one additional segmented electrode in addition to the first pair of segmented electrodes, wherein the at least one additional segmented electrode is not electrically ganged to the first pair of segmented electrodes.

4. The stimulation lead of claim 3, wherein the at least one additional segmented electrode comprises a second pair of the segmented electrodes that are disposed on opposite sides of the lead body and are electrically ganged together by a conductor therebetween.

5. The stimulation lead of claim 4, wherein the first pair and the second pair are radially offset by an angle in a range of 75 to 115 degrees with respect to each other.

6. The stimulation lead of claim 1, wherein the plurality of groups of segmented electrodes comprises a second group disposed at a different longitudinal position than the first group, the second group comprising a second pair of the segmented electrodes which are disposed on opposite sides of the lead body and are electrically ganged together by a conductor therebetween.

7. The stimulation lead of claim 6, wherein the first pair and the second pair are radially offset by an angle in a range of 75 to 115 degrees with respect to each other.

8. The stimulation lead of claim 7, wherein the first pair longitudinally overlaps with the second pair.

9. The stimulation lead of claim 6, wherein the first and second pairs of the segmented electrodes are radially aligned with each other.

10. The stimulation lead of claim 9, wherein the first group comprises a third pair of the segmented electrodes which are disposed on opposite sides of the lead body and are electrically ganged together by a conductor therebetween and the second group comprises a fourth pair of the segmented electrodes which are disposed on opposite sides of the lead body and are electrically ganged together by a conductor therebetween.

11. The stimulation lead of claim 10, wherein the third and fourth pairs of the segmented electrodes are radially aligned with each other.

12. The stimulation lead of claim 1, wherein the plurality of electrodes further comprises at least one ring electrode.

13. The stimulation lead of claim 1, further comprising a plurality of terminals disposed along the longitudinal surface of the lead body near the proximal end of the lead body and electrically coupled to the plurality of electrodes.

14. A kit for implanting a stimulation lead into a patient, the kit comprising:

- a stimulation lead comprising a longitudinal surface, a distal end, and at least one electrode disposed along the longitudinal surface of the stimulation lead near the distal end of the stimulation lead, wherein a portion of the stimulation lead upon which the electrodes are disposed has a non-circular cross-sectional shape;

at least one microelectrode lead comprising a distal end and at least one microelectrode disposed at the distal end of the microelectrode lead; and

an introducer defining a lumen configured and arranged to receive the stimulation lead, the introducer further comprising at least one interior wall extending into the lumen and defining at least one microelectrode lumen that is configured and arranged to receive, and hold within the microelectrode lumen, a one of the at least one microelectrode leads.

15. The kit of claim 14, wherein the introducer comprises at least two interior walls defining at least two microelectrode lumens.

16. The kit of claim 14, wherein the stimulation lead further comprises a proximal end, two main portions disposed at the distal end of the lead, a bendable portion disposed between the two main portions, and a plurality of terminals disposed along the proximal end of the lead and electrically coupled to the plurality of electrodes, wherein the bendable portion is bent so that the two main portions are disposed opposite each other and the plurality of electrodes are disposed on surfaces of the two main portions of the lead, wherein each electrode has an exposed surface through which electrical energy can be supplied to stimulate adjacent tissue when the stimulation lead is implanted.

17. A method for stimulating tissue, the method comprising:

- implanting a lead comprising a longitudinal surface, a distal end, a proximal end, two main portions disposed at the distal end of the lead, a bendable portion disposed between the two main portions, a plurality of electrodes disposed on surfaces of the two main portions of the lead, and a plurality of terminals disposed along the proximal end of the lead and electrically coupled to the plurality of electrodes, wherein the bendable portion is bent so that the two main portions are disposed opposite each other and wherein each electrode has an exposed surface through which electrical energy can be supplied to stimulate adjacent tissue when the stimulation lead is implanted;
- retaining the lead in the patient with the bendable portion bent; and
- stimulating adjacent tissue using at least one of the electrodes.

18. The method of claim 17, wherein implanting a lead comprising inserting at least the distal end of the lead into an introducer defining a lumen configured and arranged to receive the lead, the introducer further comprising at least one interior wall extending into the lumen and defining at least one microelectrode lumen that is configured and arranged to receive a microelectrode lead.

19. The method of claim 17, wherein implanting a lead further comprises inserting a microelectrode lead into the microelectrode lumen of the lead body.

20. The method of claim 17, wherein implanting a lead further comprises using the microelectrode lead to identify tissue for stimulation.

* * * * *