

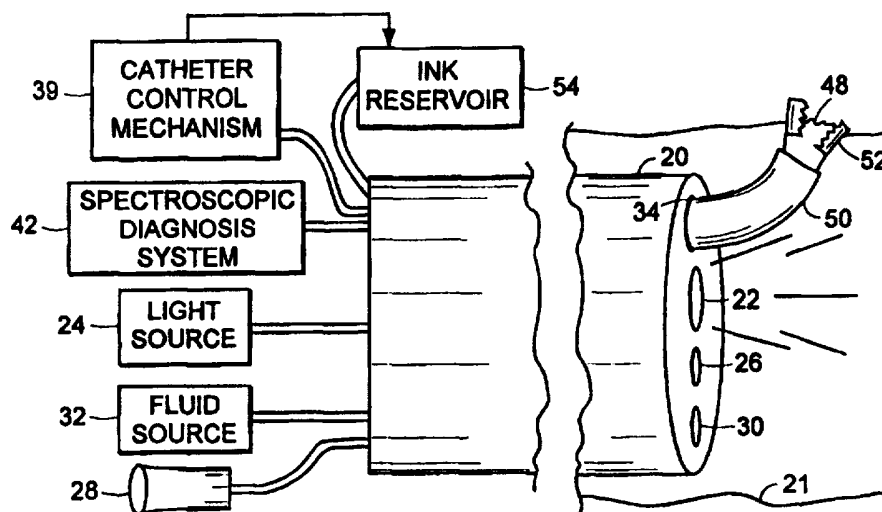

INTERNATIONAL APPLICATION PUBLISHED UNDER THE PATENT COOPERATION TREATY (PCT)

<p>(51) International Patent Classification ⁶ : A61B 17/22</p>	<p>A1</p>	<p>(11) International Publication Number: WO 98/01074 (43) International Publication Date: 15 January 1998 (15.01.98)</p>
<p>(21) International Application Number: PCT/US97/11864 (22) International Filing Date: 7 July 1997 (07.07.97) (30) Priority Data: 08/679,425 8 July 1996 (08.07.96) US (71) Applicant: BOSTON SCIENTIFIC CORPORATION [US/US]; One Boston Scientific Place, Natick, MA 01760 (US). (72) Inventors: DANIELS, Douglas, J.; 15 Pudding Stone Lane, Mendon, MA 01756 (US). BANIK, Michael, S.; 119 Wilder Road, Bolton, MA 01740 (US). (74) Agent: CAPRARO, Joseph, A.; Testa, Hurwitz & Thibault, LLP, High Street Tower, 125 High Street, Boston, MA 02110 (US).</p>		<p>(81) Designated States: CA, JP, European patent (AT, BE, CH, DE, DK, ES, FI, FR, GB, GR, IE, IT, LU, MC, NL, PT, SE). Published <i>With international search report. Before the expiration of the time limit for amending the claims and to be republished in the event of the receipt of amendments.</i></p>

(54) Title: DIAGNOSING AND PERFORMING INTERVENTIONAL PROCEDURES ON TISSUE IN VIVO



(57) Abstract

A catheter (20) for diagnosing and performing an interventional procedure on tissue has an elongated catheter shaft, and optical fibers (20, 26), extending through the catheter shaft, for transmitting light to tissue located at a distal end of the catheter and conveying light back from the tissue for analysis by a spectroscopic diagnosis system (42) to determine whether an interventional procedure should be performed on the tissue. An interventional device (52) is located at the distal end of the catheter for engaging tissue diagnosed by the spectroscopic diagnosis system in order to perform the interventional procedure on the tissue. An assembly for imaging and performing an interventional procedure on tissue has an endoscope in combination with an endoscopically insertable catheter having an ultrasound imaging device for imaging a tissue structure located at a distal end of the endoscope so as to enable the depth of penetration of the tissue structure to be displayed, and an endoscopically insertable interventional device for engaging the tissue structure imaged by the ultrasound imaging device.

FOR THE PURPOSES OF INFORMATION ONLY

Codes used to identify States party to the PCT on the front pages of pamphlets publishing international applications under the PCT.

AL	Albania	ES	Spain	LS	Lesotho	SI	Slovenia
AM	Armenia	FI	Finland	LT	Lithuania	SK	Slovakia
AT	Austria	FR	France	LU	Luxembourg	SN	Senegal
AU	Australia	GA	Gabon	LV	Latvia	SZ	Swaziland
AZ	Azerbaijan	GB	United Kingdom	MC	Monaco	TD	Chad
BA	Bosnia and Herzegovina	GE	Georgia	MD	Republic of Moldova	TG	Togo
BB	Barbados	GH	Ghana	MG	Madagascar	TJ	Tajikistan
BE	Belgium	GN	Guinea	MK	The former Yugoslav Republic of Macedonia	TM	Turkmenistan
BF	Burkina Faso	GR	Greece	ML	Mali	TR	Turkey
BG	Bulgaria	HU	Hungary	MN	Mongolia	TT	Trinidad and Tobago
BJ	Benin	IE	Ireland	MR	Mauritania	UA	Ukraine
BR	Brazil	IL	Israel	MW	Malawi	UG	Uganda
BY	Belarus	IS	Iceland	MX	Mexico	US	United States of America
CA	Canada	IT	Italy	NE	Niger	UZ	Uzbekistan
CF	Central African Republic	JP	Japan	NL	Netherlands	VN	Viet Nam
CG	Congo	KE	Kenya	NO	Norway	YU	Yugoslavia
CH	Switzerland	KG	Kyrgyzstan	NZ	New Zealand	ZW	Zimbabwe
CI	Côte d'Ivoire	KP	Democratic People's Republic of Korea	PL	Poland		
CM	Cameroon	KR	Republic of Korea	PT	Portugal		
CN	China	KZ	Kazakstan	RO	Romania		
CU	Cuba	LC	Saint Lucia	RU	Russian Federation		
CZ	Czech Republic	LI	Liechtenstein	SD	Sudan		
DE	Germany	LK	Sri Lanka	SE	Sweden		
DK	Denmark	LR	Liberia	SG	Singapore		
EE	Estonia						

DIAGNOSING AND PERFORMING INTERVENTIONAL PROCEDURES ON
TISSUE IN VIVO

Background of the Invention

This application relates to diagnosing and performing interventional procedures on tissue using endoscopically insertable catheters.

Lesions in body lumens such as the alimentary track may be diagnosed by inserting an
5 endoscope into the alimentary track and inserting through a working channel of the endoscope a
catheter having optical fibers for transmitting light to tissue located at a distal end of the catheter
and for conveying light back from the tissue for analysis by a spectroscopic diagnosis system. If
the spectroscopic diagnosis system determines an interventional procedure should be performed
on the tissue, a biopsy of the tissue may be taken or the tissue may be otherwise removed or
10 treated.

Summary of the Invention

One aspect of the invention features a catheter for diagnosing and performing an
interventional procedure on tissue. The catheter has an elongated catheter shaft, and optical
fibers, extending through the catheter shaft, transmit light to tissue located at a distal end of the
15 catheter shaft and convey light back from the tissue for analysis by a spectroscopic diagnosis
system to determine whether an interventional procedure should be performed on the tissue. An
interventional device is located at the distal end of the catheter shaft for engaging tissue diagnosed
by the spectroscopic diagnosis system in order to perform the interventional procedure on the
tissue.

20 In various embodiments the catheter is constructed to be inserted through the working
channel of an endoscope, and the interventional device is, for example, a scalpel, forceps jaws, a
snare, a scissors, or a needle. An interventional needle can be used, for example, to cut the tissue,
to apply an adhesive material to the tissue, to inject a chemical ablation fluid into the tissue, or to
inject a marking fluid into the tissue so as to enable the tissue to be treated by another
25 interventional device, which may be located on another catheter. Because the interventional
device is located on the same catheter as the optical fibers, the physician can perform the
interventional procedure on the tissue without having to remove the catheter from the patient's

- 2 -

body. Moreover, the diagnosis and interventional procedure can be accomplished at multiple sites without having to remove the catheter from the patient's body. In various embodiments the interventional device is, for example, a scalpel, forceps jaws, a snare, a scissors, or a needle.

Another aspect of the invention features an assembly comprising an endoscope, a catheter shaft insertable through a working channel of the endoscope having optical fibers for transmitting light to tissue and from tissue for analysis by a spectroscopic diagnosis system to determine whether an interventional procedure should be performed on the tissue, and an interventional device, insertable through a working channel of the endoscope, for performing the interventional procedure on the tissue.

Another aspect of the invention features a method for imaging and performing an interventional procedure on tissue. A catheter having an ultrasound imaging device located at its distal end is inserted through a working channel of an endoscope, for imaging a tissue structure located at a distal end of the endoscope, and the tissue structure is displayed in a manner that indicates the depth of penetration of the tissue structure into the body of the living being. An interventional device, which is inserted through a working channel of the endoscope, performs interventional therapy on the tissue structure in a manner responsive to the displayed depth of penetration of the tissue structure.

This aspect of the invention enables the physician to determine the depth to which a tumor has grown into or through the wall of a lumen in order to determine whether the tumor can be removed safely from the lumen. The physician can rely on the ultrasound image display to determine how much tissue to remove in view of the depth of penetration of the tissue structure, and can also observe the ultrasound image of the tissue structure while performing the interventional procedure on the tissue structure so as to ensure that an appropriate amount of tissue is removed.

In general, the invention aids physicians in the accurate early diagnosis of patients with cancer or other abnormalities inside the body. Many cancers or other abnormalities can be treated efficiently if diagnosed and treated early enough in the least invasive manner. The invention helps physicians to locate suspect areas, diagnose accurately, and sample and treat tissue efficiently. The invention also provides high diagnostic accuracy and short procedural time by providing accurate data and avoiding unnecessary biopsies. Consequently, overall health care costs are low because of low lab analysis and minimal outpatient hospital visits.

Numerous other features, objects, and advantages of the invention will become apparent from the following detailed description when read in connection with the accompanying drawings.

Brief Description of the Drawings

5 Figs. 1-6 are a set of drawings showing the steps of a process for spectroscopically diagnosing and marking tissue using an endoscopically insertable catheter and for removing tissue using another endoscopically insertable catheter.

Fig. 7 is a drawing of an endoscopically insertable catheter combining optical fibers and forceps jaws.

10 Fig. 8 is a drawing of an endoscopically insertable catheter combining optical fibers and a polypectomy snare.

Fig. 9 is a drawing of an endoscopically insertable catheter combining optical fibers and scissors.

Fig. 10 is a drawing of an endoscopically insertable catheter combining optical fibers and a needle.

15 Fig. 11 is a drawing of an endoscope in combination with an endoscopically insertable catheter having forceps jaws and an endoscopically insertable catheter having an ultrasound imaging device.

20 Fig. 12 is a drawing of an endoscope in combination with an endoscopically insertable catheter having optical fibers and forceps jaws and an endoscopically insertable catheter having an ultrasound imaging device.

Detailed Device

25 Figs. 1-6 refer to an endoscopically insertable catheter having optical fibers for transmitting light to tissue and for conveying light back from tissue for analysis by a spectroscopic diagnosis system and having a needle for performing an interventional procedure on the tissue, namely, injecting india ink into tissue diagnosed by the spectroscopic diagnosis system in order to mark the tissue for biopsy, treatment, or removal by another interventional device. If the spectroscopic diagnosis system determines that the tissue should be treated, the catheter having the optical fibers and needle is withdrawn from the endoscope and a catheter having forceps jaws is inserted through the endoscope in order to obtain a biopsy of the tissue or to remove or treat
30 the tissue.

- 4 -

With reference to Fig. 1, a distal end of an endoscope 20 is inserted through a lumen 21 of a patient's body, such as the esophagus, rectum or pulmonary tract. Endoscope 20 has an optical fiber 22 connected to a light source 24 located at a proximal end of endoscope 20 for transmitting light to tissue located at the distal end of endoscope 20, an optical fiber 26 connected to an
5 eyepiece 28 located at the proximal end of endoscope 20 for viewing the tissue, a fluid channel 30 connected to a fluid source 32 located at the proximal end of endoscope 20 for flushing the tissue with fluid such as a wash for the visual fiber optics, and a working channel 34 for receiving a catheter. In Fig. 1, light source 24 is turned on.

With reference to Fig. 2, a catheter 36 having an elongated catheter shaft is inserted
10 through working channel 34 of endoscope 20. Catheter 36 has optical fibers 38 and 40, which extend through the catheter shaft and are connected to a spectroscopic diagnosis system 42 located at the proximal end of endoscope 20. Optical fibers 38 and 40 can be made of a quartz glass component or other suitable glass or polymer material capable of transmitting and receiving wavelengths necessary to distinguish between healthy and abnormal tissue that has been treated by
15 a diagnostic reagent. The optical fibers may be bundled together as a single light transmission and reception probe rather than the two discrete fibers shown in Figs. 1-5, the probe including an outer sheath made of SST or a suitable semi-rigid polymer that is non-reactive to diagnostic reagents. Catheter 36 is connected to a catheter control mechanism 39 located at the proximal end of endoscope 20 that controls the longitudinal movement of catheter 36 within working
20 channel 34. Catheter control mechanism 39 also controls the longitudinal movement of optical fibers 38, 40 and may extend or retract optical fibers 38, 40 with respect to catheter 36. In Fig. 2, light source 24 is turned on and optical fibers 38, 40 are extended from catheter 36 to the tissue.

With reference to Fig. 3, light source 24 is turned off, optical fiber 38 transmits light to the tissue, and optical fiber 40 conveys light back from the tissue for analysis by spectroscopic
25 diagnosis system 42 to determine whether the tissue should be treated.

For example, optical fiber 38 transmits a monochromatic light beam having a wavelength or set of wavelengths selected to cause the tissue to fluoresce in a manner such that at one wavelength of the fluorescent light the intensity is approximately the same regardless of whether the tissue is normal or cancerous and at another wavelength of the fluorescent light the intensity
30 differs substantially depending on whether the tissue is normal or cancerous. By analyzing the ratio of the intensity of the fluorescent light at the wavelength at which the intensity is

- 5 -

approximately the same regardless of whether the tissue is normal or cancerous to the intensity of the fluorescent light at the wavelength at which the intensity differs substantially depending whether the tissue is normal or cancerous, spectroscopic diagnosis system 42 can determine whether the tissue is normal or cancerous, and in some instances whether the tissue is a benign tumor. The tissue may first be treated by a diagnostic reagent that bonds more selectively with diseased (cancerous) tissue than with normal tissue, or vice versa, and that absorbs light transmitted through the catheter and thereby causes the tissue to fluoresce at a wavelength or set of wavelengths different from the transmission wavelength. The intensity of the light conveyed back to the spectroscopic diagnosis system may be displayed graphically through the aid of a computer as a function of wavelength, and the endoscopist can interpret the data.

Referring to Fig. 4, if spectroscopic diagnosis system 42 determines that the tissue should be treated, catheter control mechanism 39 retracts optical fibers 38 and 40 into catheter 36, and light source 24 is turned on. Catheter control mechanism 39 also controls the longitudinal movement of a needle 44 which is located at the distal end of catheter 36 and extends needle 44 to the tissue. Needle 44, which can be made of SST or a suitable semirigid polymer that is non-reactive to diagnostic reagents, extends through a lumen 46 in the catheter shaft. Needle 44 and optical fibers 38 and 40 may be combined together as a single probe. Catheter control mechanism 39 causes india ink 48 from ink reservoir 54 to be injected through needle 44 into the tissue to be treated.

Optical fiber 38 transmits light to the tissue at a number of points and optical fiber 40 conveys light back from the tissue for analysis by spectroscopic diagnosis system 42 in order to determine whether the tissue is cancerous at each of these points. Each such point that is determined to be cancerous is marked by india ink 48 using needle 44.

With reference to Fig. 5, light source 24 is turned on, and catheter 36 having optical fibers 38, 40 and needle 44 is withdrawn from working channel 34, and a catheter 50 having forceps jaws 52 located at its distal end is inserted through working channel 34. Forceps jaws 52 are used to remove the tissue diagnosed by the spectroscopic diagnosis system 42 and marked by india ink 48.

Numerous other embodiments are also within the scope of the claims. For example, Figs. 6-10 are drawings of different embodiments of an endoscopically insertable catheter 100 combining optical fibers and various other types of interventional devices. Catheter 100 can be

inserted in an endoscope as shown in Figs. 1-5 in order to perform spectroscopic diagnosis on tissue and remove cancerous tissue without having to mark the cancerous tissue with india ink. After the interventional device removes the cancerous tissue, the optical fibers are used to perform spectroscopic diagnosis on the remaining tissue to determine whether all of the cancerous
5 tissue has been removed.

In Fig. 6, catheter 100 has optical fibers 102, 104 glued to a surface of a scalpel 106.

In Fig. 7, catheter 100 has optical fibers 102, 104 placed between forceps jaws 108, which may be multiple sampling biopsy forceps jaws capable of removing multiple samples of tissue into the body of catheter 100 as described in U.S. Patent Application No. 08/193,382, the entire
10 disclosure of which is hereby incorporated herein by reference. The forceps jaws are caused to open up as shown in Fig. 7 by the withdrawal of an outer sleeve of the catheter (not shown) in the proximal direction and are caused to close together by pushing the outer sleeve in the distal direction. There is a hole at the tip of the forceps jaws through which the optical fibers can extend, the optical fibers being extendable and retractable with respect to the catheter and with
15 respect to the forceps jaws. The forceps jaws can be used to remove tissue known to be unhealthy or to obtain biopsy samples for additional, cellular analysis. The optical fibers are of course retracted when the forceps jaws are being used. If the forceps jaws are of the multiple-biopsy type, the optical fibers can be bundled together as a single probe designed to spear through the biopsy samples within the catheter for continued diagnosis at additional sites.

Referring to Fig. 8, catheter 100 has optical fibers 102, 104 placed next to a polypectomy
20 snare 110, which can be looped around a polyp and quickly retracted into catheter 100 to excise the polyp. The optical fibers may alternatively pass through the same lumen as the snare.

Referring to Fig. 9, catheter 100 has optical fibers 102, 104 placed next to scissors 112. Alternatively, the optical fibers may be glued to one of the scissors blades.

In Fig. 10, catheter 100 has optical fibers 102, 104 placed next to a needle 114, similar in
25 construction to needle 44 described above in connection with Figs. 1-5. Needle 114 may be constructed to inject chemical ablation fluid or other drugs into tissue, possibly including time-release capsules containing cancer-fighting substances, to cut tissue, or to apply glue for temporarily adhering tissue between the esophagus and the stomach for treating gastroesophageal
30 reflux disease. Localized chemical ablation or drug treatment can be performed at high concentration because of the specificity with which spectroscopic diagnosis can identify the

- 7 -

location of unhealthy tissue. Needle 114 of Fig. 10 or needle 44 of Figs. 1-5 can also be used to inject a diagnostic reagent into a suspect site that bonds more selectively with diseased (cancerous) tissue than with normal tissue, or vice versa, as described above. Such a needle for injection of a diagnostic reagent can also be included in any of the catheters of Figs. 6-9. In each of the embodiments of Figs. 6-10, optical fibers 102, 104 are extendable and retractable with respect to catheter 100, and with the exception of the embodiment of Fig. 6, in which the optical fibers are glued to scalpel 106, any movement capabilities of optical fibers 102, 104 on the one hand and the interventional device on the other hand can be completely independent of each other.

Each of the embodiments described above in connection with Figs. 1-10 can be modified by eliminating the endoscope and adding additional optical fibers to the catheter for use in connection with the imaging function, or by using one or more optical fibers of the catheter not only in connection with spectroscopic diagnosis function but also in connection with the imaging function. Since the catheter would be used without an endoscope, the catheter would have a steerable tip to allow movement and positioning of the catheter. The lumen of the catheter needle, in embodiments having such a needle, can double as a wash for the visual fiber optics as well as a vacuum and air source. One advantage of such a construction is that the catheter would not have to be as large as an endoscope combined with a catheter, because no endoscope working channel is required.

With reference to Fig. 11, an endoscope 200 is combined with an endoscopically insertable catheter 216 having forceps jaws 218 and an endoscopically insertable catheter 212 having a rotatable ultrasound imaging transducer 214. Ultrasound imaging transducer 214 provides a visual image of the tumor, which can be useful in determining the depth to which a tumor has grown into or through the wall of a lumen in order to determine whether the tumor can be removed safely from the lumen. If the tissue structure imaged by ultrasound imaging transducer 214 can be removed safely from the lumen, forceps jaws 218 are used to remove the tissue structure. The visual image can also be used to determine how much tissue should be removed. The imaging can be performed simultaneously with the tissue removal, so as to enable the physician to see whether the tissue structure has been completely removed.

Endoscope 200 has an optical fiber 202 for transmitting light from light source 230 to tissue located at a distal end of endoscope 200, an optical fiber 204 for conveying light back from the tissue to eyepiece 234 for viewing tissue, a fluid channel 206 for flushing tissue with fluid

- 8 -

provided by fluid source 232, and working channels 208, 210 for receiving catheters 212 and 216 respectively. Interventional catheter control mechanism 224 controls the longitudinal movement of catheter 216 within working channel 210 as well as the operation of forceps jaws 218.

Similarly, ultrasound catheter control mechanism 226 controls the longitudinal movement
5 of ultrasound catheter 212 within working channel 208 as well as the operation of ultrasound transducer 214, including its rotation, transmission of ultrasound pulses, and detection of reflected pulses by the transducer. The ultrasound image of the tissue imaged by the ultrasound transducer is displayed by ultrasound image display 228.

The endoscope of Fig. 11 also may be used in combination with any of the different
10 endoscopically insertable catheters combining optical fibers and interventional devices described above and shown in Figs. 6-10, which may be substituted for interventional catheter 216.

For example, in Fig. 12, catheter 216 has forceps jaws 218 and optical fibers 220, 222,
which are connected to a spectroscopic diagnosis system 236 that spectroscopically diagnoses the tissue to determine whether the tissue should be treated, as is described above in connection with
15 Fig. 7.

If the tissue is found to be cancerous or otherwise in need of removal, ultrasound imaging catheter 214 is used to measure the depth to which a tumor has grown into or through the wall of a lumen to determine whether the tumor can be removed safely from the lumen. If the cancerous tissue imaged by ultrasound imaging device 214 can be removed safely from the lumen, forceps
20 jaws 218 are used to remove the cancerous tissue. After forceps jaws 218 remove the cancerous tissue, optical fibers 220, 222 are used to perform spectroscopic diagnosis on the tissue to determine whether all of the cancerous tissue has been removed.

There have been described novel and improved apparatus and techniques for diagnosing and performing interventional procedures on tissue. It is evident that those skilled in the art may
25 now make numerous uses and modifications of and departures from the specific embodiments described herein without departing from the inventive concept. For example, other interventional devices may be substituted for the ones described above and set forth in the drawings.

CLAIMS

What is claimed is:

- 1 1. A catheter, comprising: an elongated catheter shaft; an optical fiber, extending through
2 the catheter shaft, for transmitting light to tissue located at a distal end of the catheter shaft; an
3 optical fiber, extending through the catheter shaft, for conveying light back from the tissue for
4 analysis by a spectroscopic diagnosis system to determine whether an interventional procedure
5 should be performed on the tissue; and
6 an interventional device located at the distal end of the catheter shaft for engaging tissue
7 diagnosed by the spectroscopic diagnosis system in order to perform the interventional procedure
8 on the tissue.
- 1 2. The catheter of claim 1, wherein the optical fiber for transmitting light to tissue is distinct
2 form the optical fiber for conveying light back from the tissue.
- 1 3. The catheter of claim 1, wherein the interventional device comprises a scalpel.
- 1 4. The catheter of claim 1, wherein the interventional device comprises forceps jaws.
- 1 5. The catheter of claim 1, wherein the interventional device comprises a snare.
- 1 6. The catheter of claim 1, wherein the interventional device comprises a scissors.
- 1 7. The catheter of claim 1, wherein the interventional device comprises a needle.
- 1 8. The catheter of claim 7, wherein the needle is constructed to inject a marking fluid into the
2 tissue.
- 1 9. The catheter of claim 7, wherein the needle is constructed to inject a chemical ablation
2 fluid into the tissue.
- 1 10. The catheter of claim 7, wherein the needle is constructed to cut the tissue.
- 1 11. The catheter of claim 7, wherein the needle is constructed to apply an adhesive material to
2 the tissue.
- 1 12. The catheter of claim 7, wherein the needle is constructed to convey a fluid to the tissue
2 useful for enabling visual observation of the tissue.
- 1 13. The catheter of claim 7, wherein the needle is constructed to apply a vacuum to the tissue.

- 1 14. The catheter of claim 11, wherein the catheter shaft is constructed to be inserted through a
2 working channel of an endoscope.
- 1 15. The catheter of claim 1, wherein at least one of the optical fibers is further constructed for
2 conveying visualization light to the tissue.
- 1 16. The catheter of claim 1, wherein at least one of the optical fibers is further constructed for
2 conveying light back from the tissue for visual observation of the tissue.
- 1 17. A method of diagnosing and performing an interventional procedure on tissue, comprising
2 the steps of: inserting into a lumen of a body of a living being a catheter having a first optical
3 fiber for transmitting light to tissue located at a distal end of the catheter, a second optical fiber
4 for conveying light back from the tissue for analysis by a spectroscopic diagnosis system, and an
5 interventional device; transmitting light through the first optical fiber to tissue located at a distal
6 end of the catheter; conveying light back from the tissue through the second optical fiber for
7 analysis by a spectroscopic diagnosis system; diagnosing the tissue with the spectroscopic
8 diagnosis system to determine whether an interventional procedure should be performed on the
9 tissue; and engaging, with the interventional device, the tissue diagnosed by the spectroscopic
10 diagnosis system in order to perform the interventional procedure on the tissue.
- 1 18. The method of claim 17, wherein the interventional procedure comprises marking the
2 tissue by injecting a marking fluid into the tissue with the interventional device.
- 1 19. The method of claim 18, wherein the marking fluid is india ink.
- 1 20. The method of claim 18, further comprising the steps of:
2 withdrawing the catheter having the optical fibers and the interventional device; inserting into the
3 body of the living being a second catheter having a second interventional device located at its
4 distal end; and engaging, with the second interventional device of the second catheter, the tissue
5 diagnosed by the spectroscopic diagnosis system in order to perform another interventional
6 procedure on the tissue.
- 1 21. The method of claim 17, wherein the step of diagnosing the tissue using the spectroscopic
2 diagnosis system comprises determining whether an interventional procedure should be performed
3 on the tissue.

- 1 22. The method of claim 17, wherein the interventional procedure comprises removing tissue
2 for biopsy analysis.
- 1 23. The method of claim 17, wherein the interventional procedure comprises removing tissue
2 diagnosed by the spectroscopic diagnosis system as being unhealthy.
- 1 24. The method of claim 17, wherein the lumen comprises an alimentary lumen.
- 1 25. The method of claim 17, wherein the lumen comprises a pulmonary lumen.
- 1 26. The method of claim 17, wherein the step of diagnosing the tissue further comprises
2 determining whether the tissue is a tumor.
- 1 27. The method of claim 26y, wherein the step of diagnosing the tissue further comprises
2 determining whether the tumor is cancerous.
- 1 28. The method of claim 17, further comprising the step of inserting through the lumen of the
2 body of the living being an endoscope having a working channel, and wherein the step of inserting
3 the catheter into the body of the living being comprises inserting the catheter into the working
4 channel of the endoscope.
- 1 29. The method of claim 17, further comprising the step of conveying visualization light to the
2 tissue through at least one of the optical fibers.
- 1 30. The method of claim 17, further comprising the step of conveying light back from the
2 tissue through at least one of the optical fibers for visual observation of the tissue.
- 1 31. The method of claim 17, further comprising the step of conveying a fluid through the
2 catheter shaft to the tissue useful for enabling visual observation of the tissue.
- 1 32. The method of claim 17, further comprising the step of applying a vacuum to the tissue
2 through the catheter shaft.
- 1 33. An assembly comprising:
2 an endoscope;
3 an elongated catheter shaft constructed to be inserted through a working channel
4 of the endoscope;
5 an optical fiber, extending through the catheter shaft, for transmitting light to
6 tissue located at a distal end of the catheter shaft;

- 12 -

7 an optical fiber, extending through the catheter shaft, for conveying light back
8 from the tissue for-analysis by a spectroscopic diagnosis system to determine whether an
9 interventional procedure should be performed on the tissue; and

10 an interventional device, constructed to be inserted through a working channel of
11 the endoscope, for engaging tissue diagnosed by the spectroscopic diagnosis system in order to
12 perform the interventional procedure on the tissue.

1 34. The assembly of claim 33 wherein the interventional device is located at the distal end of
2 the catheter shaft having the optical fibers.

1 35. A method of diagnosing and performing an interventional procedure on tissue, comprising
2 the steps of: inserting an endoscope through a lumen of a body of a living being; inserting
3 through a working channel of the endoscope a catheter having a first optical fiber for transmitting
4 light to tissue located at a distal end of the catheter and a second optical fiber for conveying light
5 back from the tissue for analysis by a spectroscopic diagnosis system; transmitting light through
6 the first optical fiber to tissue located at a distal end of the catheter; conveying light back form the
7 tissue through the second optical fiber for analysis by a spectroscopic diagnosis system;
8 diagnosing the tissue with the spectroscopic diagnosis system to determine whether an
9 interventional procedure should be performed on the tissue; and engaging, with an interventional
10 device inserted through a working channel of the endoscope, the tissue diagnosed by the
11 spectroscopic diagnosis system in order to perform the interventional procedure on the tissue.

1 36. A method of imaging and performing an interventional procedure on tissue, comprising
2 the steps of: inserting an endoscope through a lumen of a body of a living being;

3 inserting through a working channel of the endoscope a catheter having an ultrasound
4 imaging device located at its distal end;

5 imaging a tissue structure located at a distal end of the endoscope with the ultrasound
6 imaging device and displaying the tissue structure n a manner that indicates the depth of
7 penetration of the tissue structure into the body of the living being; and

8 engaging, with an interventional device inserted through a working channel of the
9 endoscope, the tissue structure imaged by the ultrasound imaging device in order to perform
10 interventional therapy on the tissue structure, the interventional therapy being performed in a
11 manner responsive to the displayed depth of penetration of the tissue structure.

1 37. The method of claim 36, wherein the interventional device is located at the distal end of an
2 interventional catheter distinct from the catheter having the ultrasound device, there are at least
3 two working channels of the endoscope, and the catheter having the ultrasound device is inserted
4 through a first of the two working channels and the interventional catheter is inserted through a
5 second of the two working channels.

1 38. The method of claim 36, wherein the step of performing the interventional therapy in a
2 manner responsive to the displayed depth of penetration of the tissue structure comprises
3 determining whether the depth of penetration of the tissue structure is sufficiently limited such
4 that the interventional therapy is justifiable and then, if the depth of penetration is sufficiently
5 limited, performing the interventional therapy.

1 39. The method of claim 36, wherein the step of performing the interventional therapy in a
2 manner responsive to the displayed depth of penetration of the tissue structure comprises
3 removing an amount of tissue corresponding to the depth of penetration.

1 40. The method of claim 39, wherein the imaging step is performed simultaneously with the
2 step of performing the interventional therapy.

1 41. The method of claim 36, wherein the interventional device comprises a scalpel.

1 42. The method of claim 36, wherein the interventional device comprises forceps jaws.

1 43. The method of claim 36, wherein the interventional device comprises a snare.

1 44. The method of claim 36, wherein the interventional device comprises a scissors.

1 45. The method of claim 36, wherein the interventional device comprises a needle.

1 46. The method of claim 45, wherein the step of engaging the tissue structure with the
2 interventional device comprises injecting a chemical ablation fluid into the tissue through the
3 needle.

1 47. The method of claim 45, wherein the step of engaging the tissue structure with the
2 interventional device comprises cutting the tissue with the needle.

1 48. The method of claim 45, wherein the step of engaging the tissue structure with the
2 interventional device comprises applying an adhesive material to the tissue using the needle.

- 1 49. The method of claim 36, further comprising the step of transmitting light to the tissue
2 structure, conveying light back from the tissue for analysis by a spectroscopic diagnosis system,
3 and determining, using the spectroscopic diagnosis system, whether an interventional procedure
4 should be performed on the tissue.
- 1 50. The method of claim 36, wherein the lumen comprises an alimentary lumen.
- 1 51. The method of claim 36, wherein the lumen comprises a pulmonary lumen.

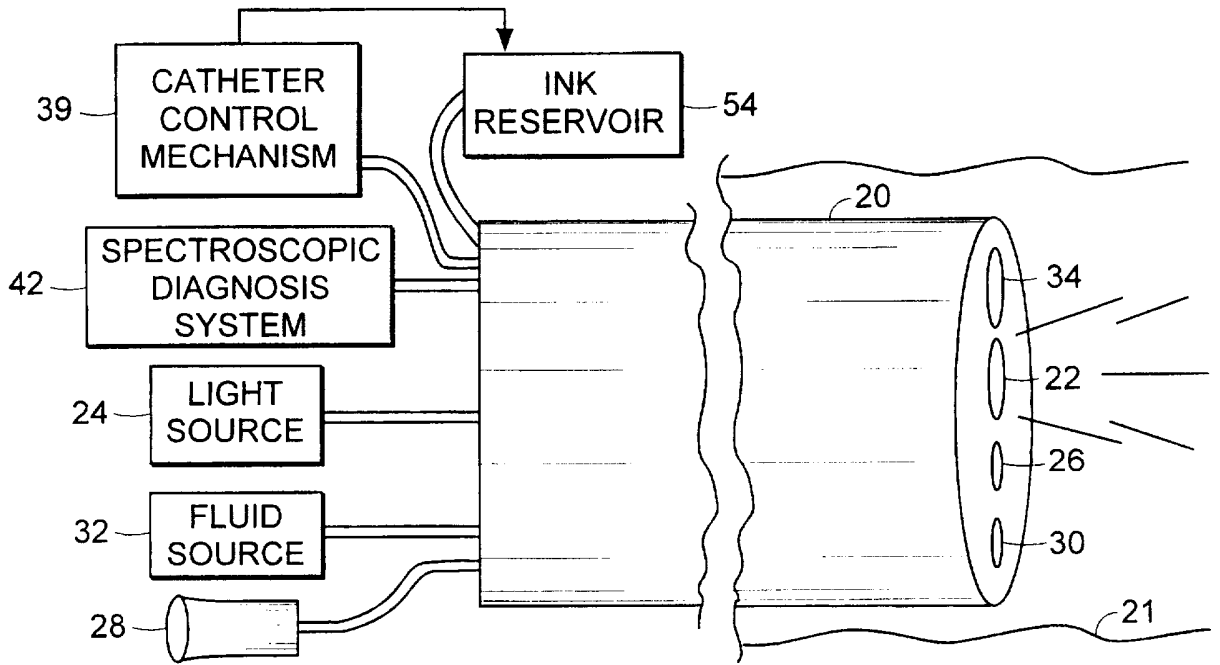

FIG. 1

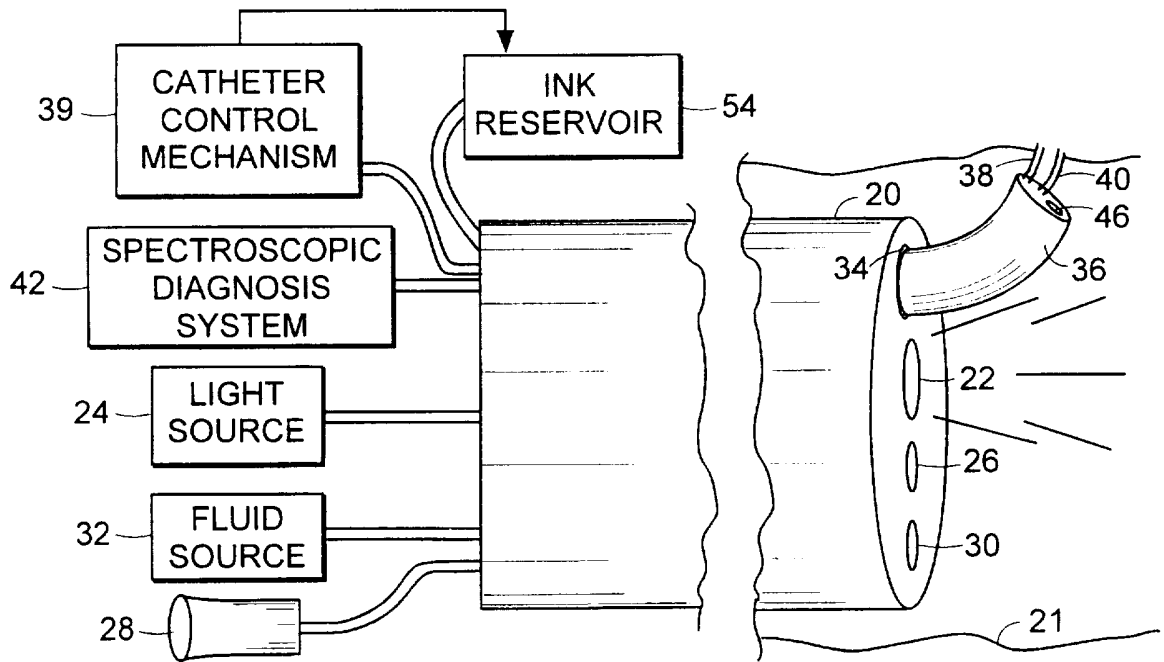

FIG. 2

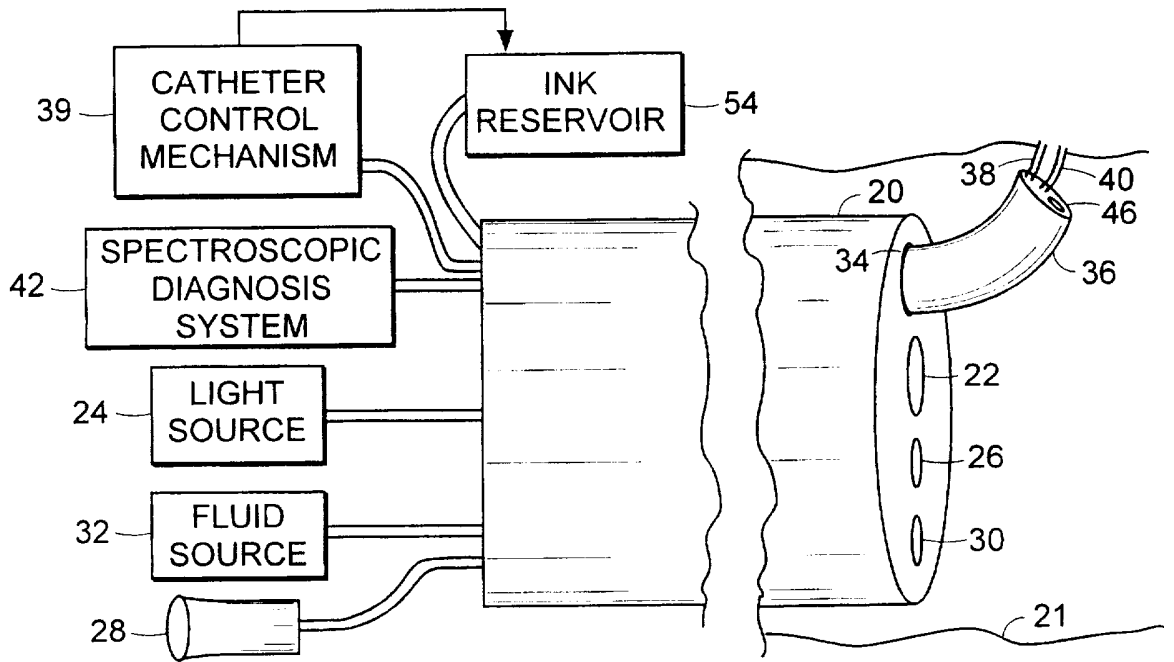

FIG. 3

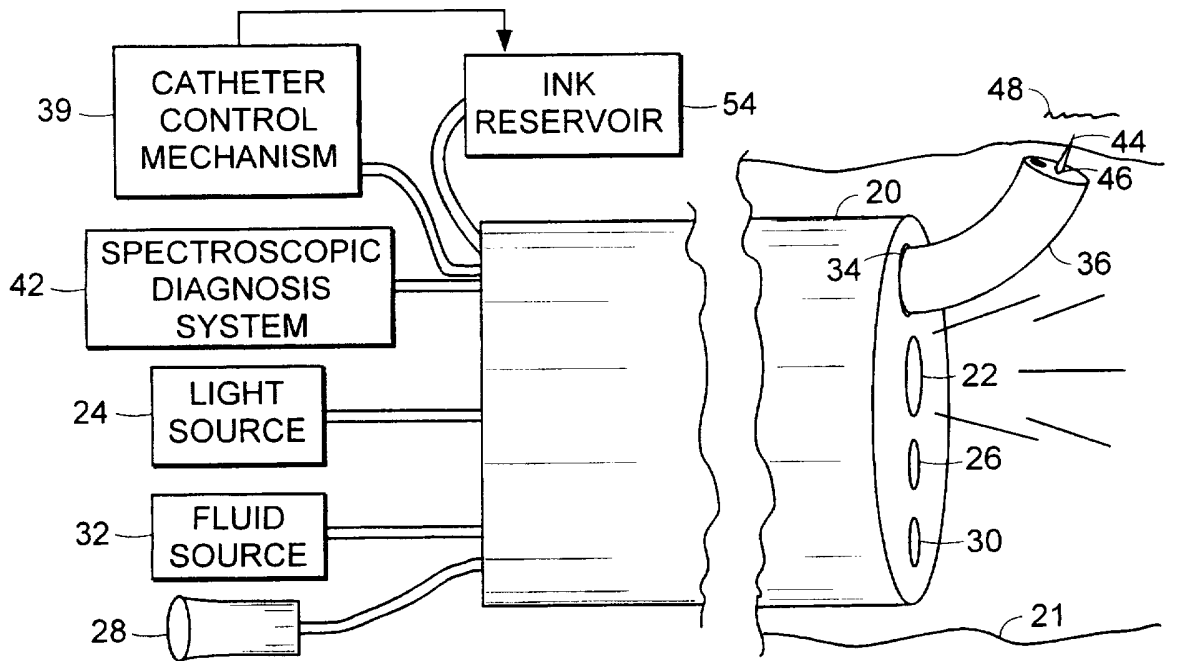

FIG. 4

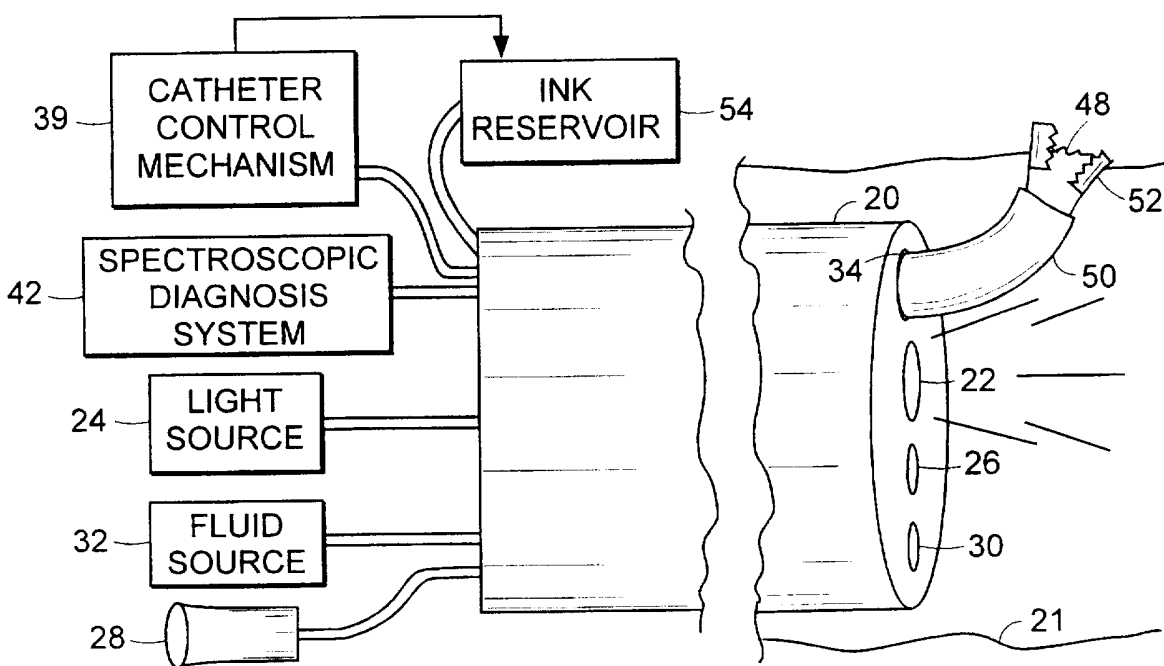
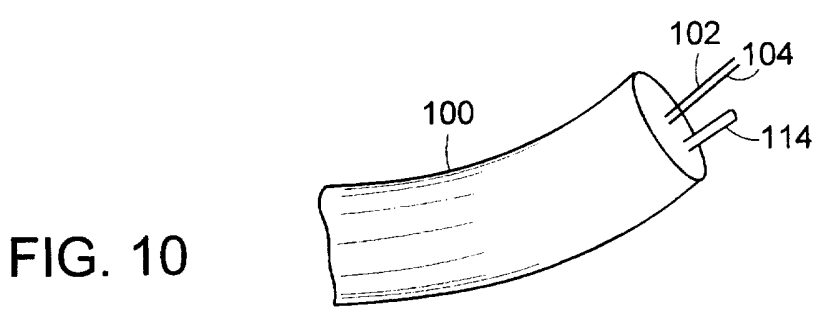
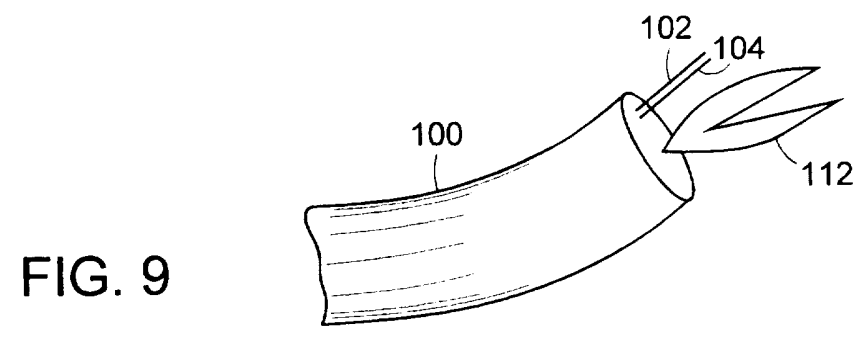
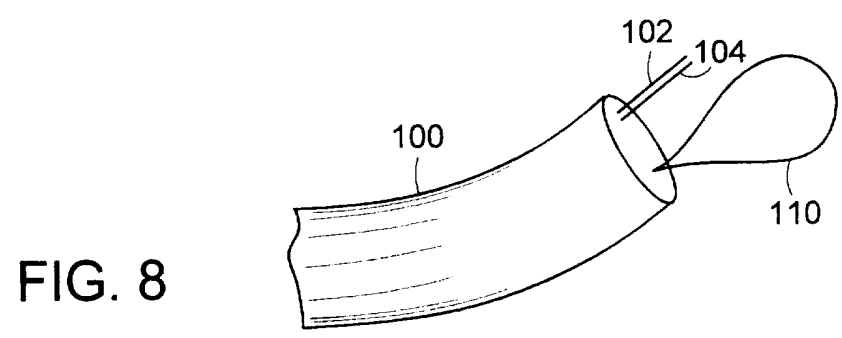
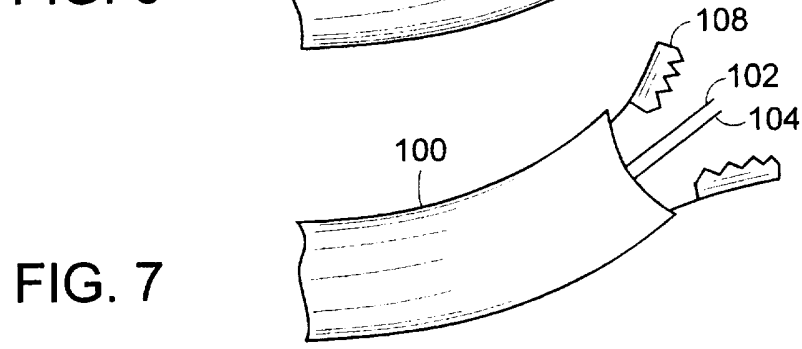
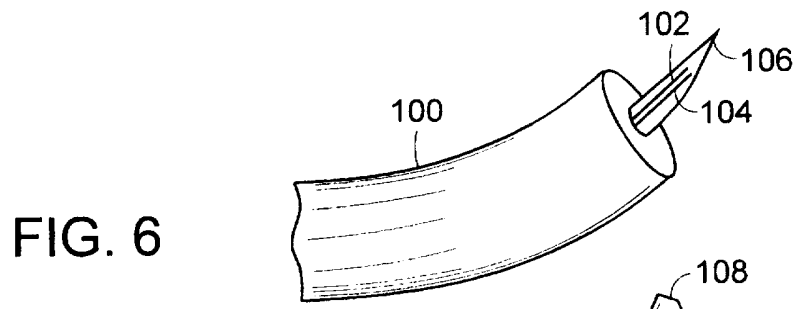

FIG. 5



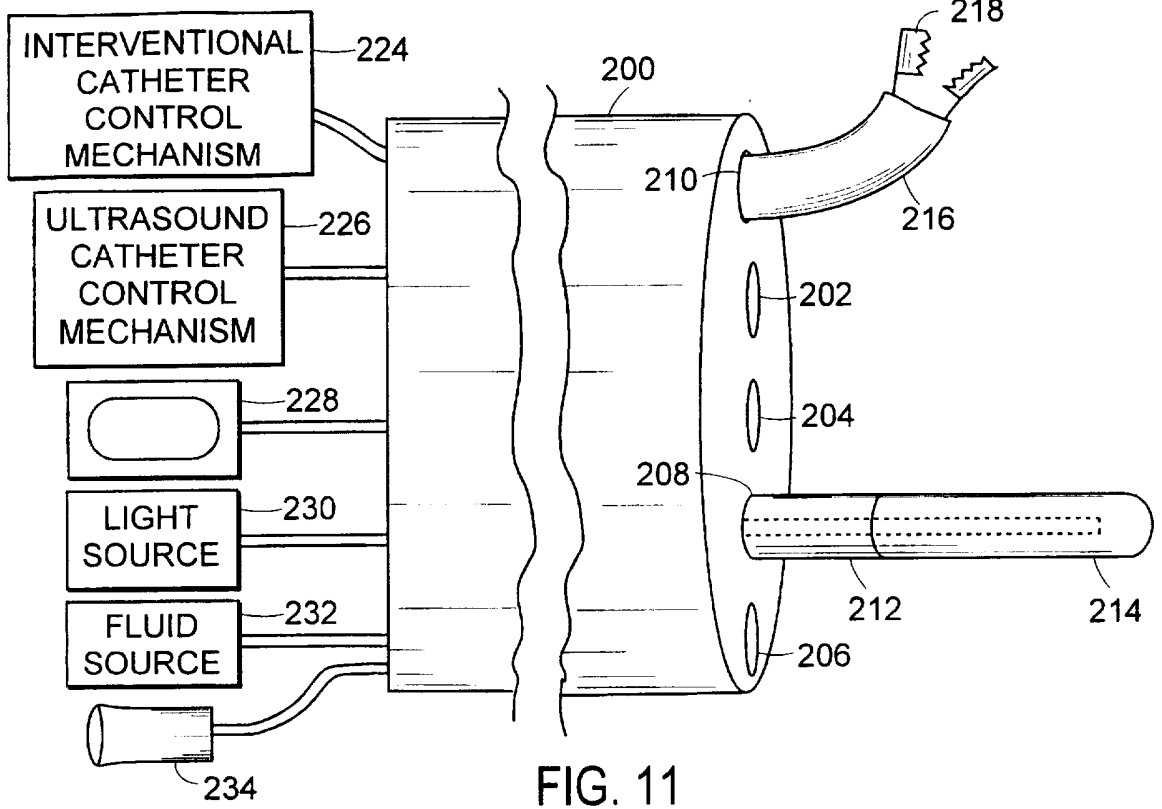

FIG. 11

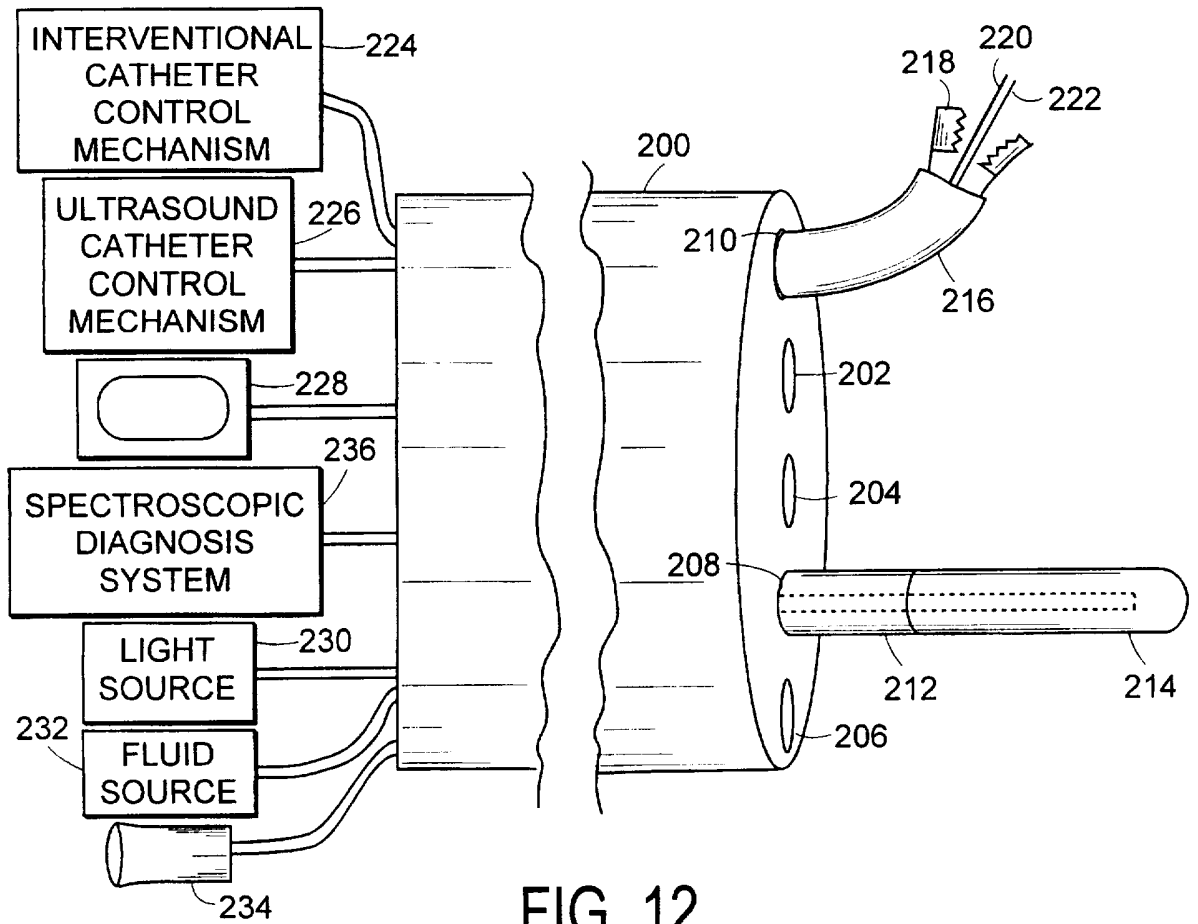

FIG. 12

INTERNATIONAL SEARCH REPORT

International Application No
PCT/US 97/11864

A. CLASSIFICATION OF SUBJECT MATTER
IPC 6 A61B17/22

According to International Patent Classification (IPC) or to both national classification and IPC

B. FIELDS SEARCHED

Minimum documentation searched (classification system followed by classification symbols)
IPC 6 A61B

Documentation searched other than minimum documentation to the extent that such documents are included in the fields searched

Electronic data base consulted during the international search (name of data base and, where practical, search terms used)

C. DOCUMENTS CONSIDERED TO BE RELEVANT

Category *	Citation of document, with indication, where appropriate, of the relevant passages	Relevant to claim No.
Y	US 5 350 375 A (DECKELBAUM ET AL) 27 September 1994 see column 4, line 38 - line 46 see column 5, line 59 - column 6, line 5 ---	1-16,33, 34
Y	WO 94 11771 A (CLARUS MEDICAL SYSTEMS) 26 May 1994 see page 4, line 13 - line 17 see page 5, line 18 - line 25 see page 7, line 31 - line 36 ---	1-16,33, 34
A	EP 0 248 761 A (FOGARTY) 9 December 1987 see column 3, line 21 - line 38 ---	1,3,16, 34
	-/--	

Further documents are listed in the continuation of box C.

Patent family members are listed in annex.

* Special categories of cited documents :

- *A* document defining the general state of the art which is not considered to be of particular relevance
- *E* earlier document but published on or after the international filing date
- *L* document which may throw doubts on priority claim(s) or which is cited to establish the publication date of another citation or other special reason (as specified)
- *O* document referring to an oral disclosure, use, exhibition or other means
- *P* document published prior to the international filing date but later than the priority date claimed

- *T* later document published after the international filing date or priority date and not in conflict with the application but cited to understand the principle or theory underlying the invention
- *X* document of particular relevance; the claimed invention cannot be considered novel or cannot be considered to involve an inventive step when the document is taken alone
- *Y* document of particular relevance; the claimed invention cannot be considered to involve an inventive step when the document is combined with one or more other such documents, such combination being obvious to a person skilled in the art.
- *Z* document member of the same patent family

Date of the actual completion of the international search

22 October 1997

Date of mailing of the international search report

10.11.97

Name and mailing address of the ISA
European Patent Office, P.B. 5818 Patentlaan 2
NL - 2280 HV Rijswijk
Tel. (+31-70) 340-2040, Tx. 31 651 epo nl,
Fax: (+31-70) 340-3016

Authorized officer

Glas, J

INTERNATIONAL SEARCH REPORT

Internatio. Application No

PCT/US 97/11864

C.(Continuation) DOCUMENTS CONSIDERED TO BE RELEVANT

Category	Citation of document, with indication, where appropriate, of the relevant passages	Relevant to claim No.
A	WO 94 10920 A (CLARUS MEDICAL SYSTEMS) 26 May 1994 see claims 1,7-10 ---	1-4,6,7, 12,15, 16,34
A	EP 0 573 264 A (CEDARS-SINAI MEDICAL CENTER) 8 December 1993 see page 5, line 27 - line 30 ---	1,7,15, 16
A	WO 90 13260 A (BIEGELEISEN) 15 November 1990 see page 9, line 30 - page 10, line 5 see page 14, line 27 - page 15, line 2 ---	1,9,11, 15,16
A	US 5 122 147 A (SEWELL, JR.) 16 June 1992 see column 4, line 50 - line 60 ---	5,8
A	US 4 211 229 A (WURSTER) 8 July 1980 see column 1, line 52 - column 2, line 4 -----	14,33

INTERNATIONAL SEARCH REPORT

International application No.
PCT/US 97/11864

Box I Observations where certain claims were found unsearchable (Continuation of item 1 of first sheet)

This International Search Report has not been established in respect of certain claims under Article 17(2)(a) for the following reasons:

1. Claims Nos.: 17-32, 35-51
because they relate to subject matter not required to be searched by this Authority, namely:
PCT Rule 39.1(iv) diagnostic or treatment method
2. Claims Nos.:
because they relate to parts of the International Application that do not comply with the prescribed requirements to such an extent that no meaningful International Search can be carried out, specifically:
3. Claims Nos.:
because they are dependent claims and are not drafted in accordance with the second and third sentences of Rule 6.4(a).

Box II Observations where unity of invention is lacking (Continuation of item 2 of first sheet)

This International Searching Authority found multiple inventions in this international application, as follows:

1. As all required additional search fees were timely paid by the applicant, this International Search Report covers all searchable claims.
2. As all searchable claims could be searched without effort justifying an additional fee, this Authority did not invite payment of any additional fee.
3. As only some of the required additional search fees were timely paid by the applicant, this International Search Report covers only those claims for which fees were paid, specifically claims Nos.:
4. No required additional search fees were timely paid by the applicant. Consequently, this International Search Report is restricted to the invention first mentioned in the claims; it is covered by claims Nos.:

Remark on Protest

- The additional search fees were accompanied by the applicant's protest.
- No protest accompanied the payment of additional search fees.

INTERNATIONAL SEARCH REPORT

Information on patent family members

International Application No

PCT/US 97/11864

Patent document cited in search report	Publication date	Patent family member(s)	Publication date
US 5350375 A	27-09-94	NONE	

WO 9411771 A	26-05-94	AU 3067692 A	08-06-94
		US 5667478 A	16-09-97

EP 248761 A	09-12-87	US 4739760 A	26-04-88
		CA 1277566 A	11-12-90
		DE 3778583 A	04-06-92
		JP 1805087 C	26-11-93
		JP 5010940 B	12-02-93
		JP 62298347 A	25-12-87
		US 4768508 A	06-09-88

WO 9410920 A	26-05-94	AU 3069392 A	08-06-94
		EP 0726733 A	21-08-96

EP 573264 A	08-12-93	AU 654914 B	24-11-94
		AU 3995793 A	12-08-93
		CA 2097280 A	02-12-93
		JP 6038967 A	15-02-94
		US 5377676 A	03-01-95

WO 9013260 A	15-11-90	US 5022399 A	11-06-91
		AU 5748990 A	29-11-90

US 5122147 A	16-06-92	NONE	

US 4211229 A	08-07-80	NONE	
