

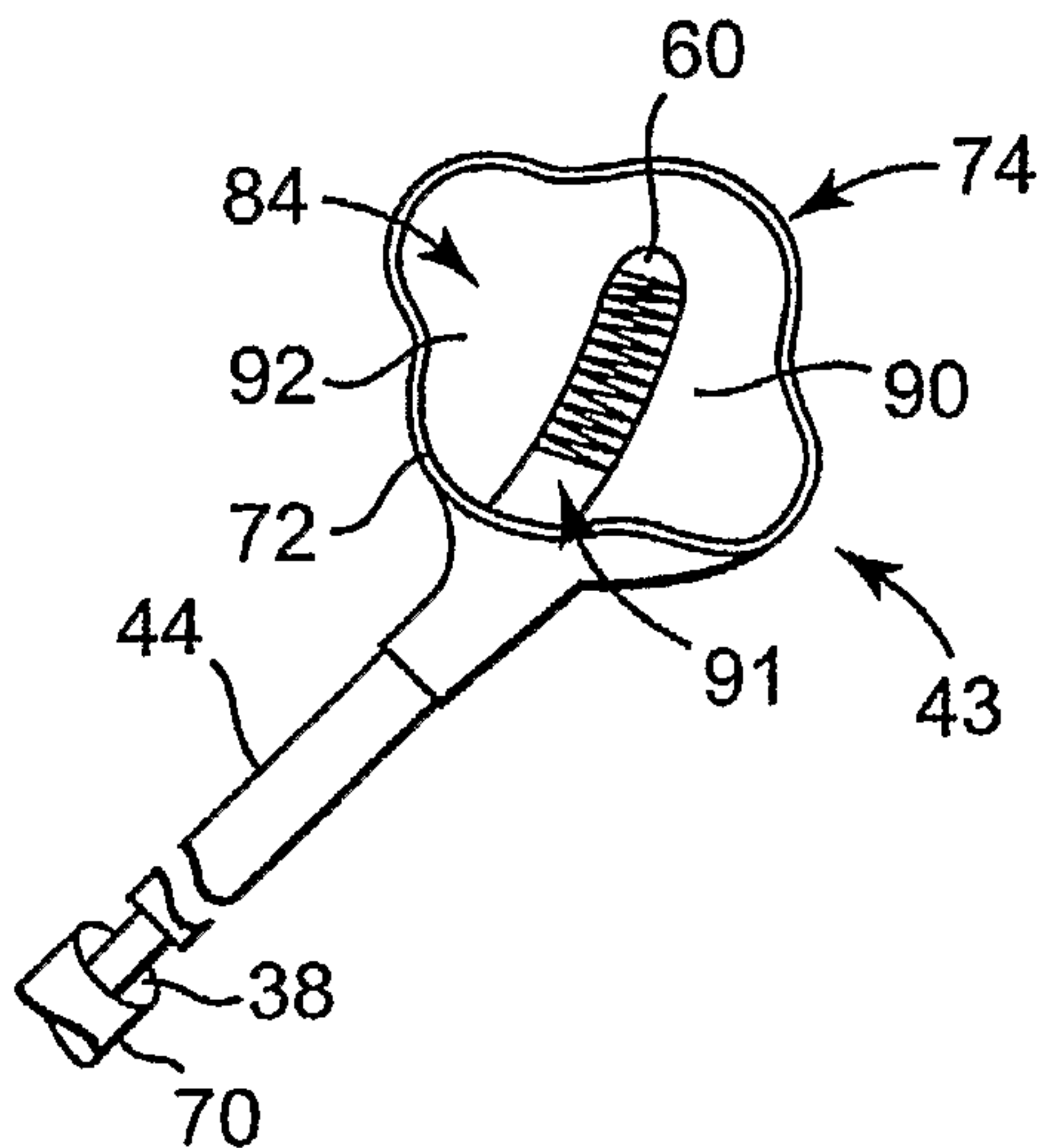


(86) Date de dépôt PCT/PCT Filing Date: 2005/05/13  
 (87) Date publication PCT/PCT Publication Date: 2005/12/01  
 (85) Entrée phase nationale/National Entry: 2006/12/06  
 (86) N° demande PCT/PCT Application No.: US 2005/016806  
 (87) N° publication PCT/PCT Publication No.: 2005/112812  
 (30) Priorité/Priority: 2004/05/14 (US60/571,182)

(51) Cl.Int./Int.Cl. *A61B 18/14* (2006.01)  
 (71) Demandeur/Applicant:  
MEDTRONIC, INC., US  
 (72) Inventeurs/Inventors:  
STEWART, MARK T., US;  
FRANCISCHELLI, DAVID E., US;  
SKARDA, JAMES R., US  
 (74) Agent: SMART & BIGGAR

(54) Titre : METHODE ET DISPOSITIFS POUR LE TRAITEMENT DE FIBRILLATION AURICULAIRE PAR ABLATION DE MASSE

(54) Title: METHOD AND DEVICES FOR TREATING ATRIAL FIBRILLATION BY MASS ABLATION



(57) Abrégé/Abstract:

Apparatus and method for ablating target tissue including a non-linear area of tissue in the left atrium of a patient. The method can include selecting an ablation apparatus having an ablator with a tissue engagement section, penetrating a chest cavity of the patient, and identifying the target tissue. The method can also include positioning the ablation apparatus adjacent to the target tissue so that the tissue engagement section can transfer ablation energy to the target tissue. The method can further include energizing the tissue engagement section with ablation energy in order to create a footprint on the non-linear area of tissue in the left atrium and to reduce an overall mass of excitable tissue in the left atrium.

## (12) INTERNATIONAL APPLICATION PUBLISHED UNDER THE PATENT COOPERATION TREATY (PCT)

(19) World Intellectual Property  
Organization  
International Bureau



(43) International Publication Date  
1 December 2005 (01.12.2005)

PCT

(10) International Publication Number  
**WO 2005/112812 A1**

(51) International Patent Classification<sup>7</sup>: **A61B 18/14**

(21) International Application Number:  
PCT/US2005/016806

(22) International Filing Date: 13 May 2005 (13.05.2005)

(25) Filing Language: English

(26) Publication Language: English

(30) Priority Data:  
60/571,182 14 May 2004 (14.05.2004) US

(71) Applicant (for all designated States except US):  
**MEDTRONIC, INC.** [US/US]; MS LC340, 710  
Medtronic Parkway, Minneapolis, MN 55432 (US).

(72) Inventors; and

(75) Inventors/Applicants (for US only): **STEWART, Mark, T.** [US/US]; 6250 Baldwin Lake Road, Lino Lakes, MN 55014 (US). **FRANCISCHELLI, David, E.** [US/US]; 744 Benton Street, Anoka, MN 55303 (US). **SKARDA, James, R.** [US/US]; 868 Jasmine Avenue, Lake Elmo, MI 55042 (US).

(74) Agents: **HOHENSHELL, Jeffrey, J.** et al.; MS LC340, 710 Medtronic Parkway, Minneapolis, MN 55432 (US).

(81) Designated States (unless otherwise indicated, for every kind of national protection available): AE, AG, AL, AM, AT, AU, AZ, BA, BB, BG, BR, BW, BY, BZ, CA, CH, CN, CO, CR, CU, CZ, DE, DK, DM, DZ, EC, EE, EG, ES, FI, GB, GD, GE, GH, GM, HR, HU, ID, IL, IN, IS, JP, KE,

KG, KM, KP, KR, KZ, LC, LK, LR, LS, LT, LU, LV, MA, MD, MG, MK, MN, MW, MX, MZ, NA, NG, NI, NO, NZ, OM, PG, PH, PL, PT, RO, RU, SC, SD, SE, SG, SK, SL, SM, SY, TJ, TM, TN, TR, TT, TZ, UA, UG, US, UZ, VC, VN, YU, ZA, ZM, ZW.

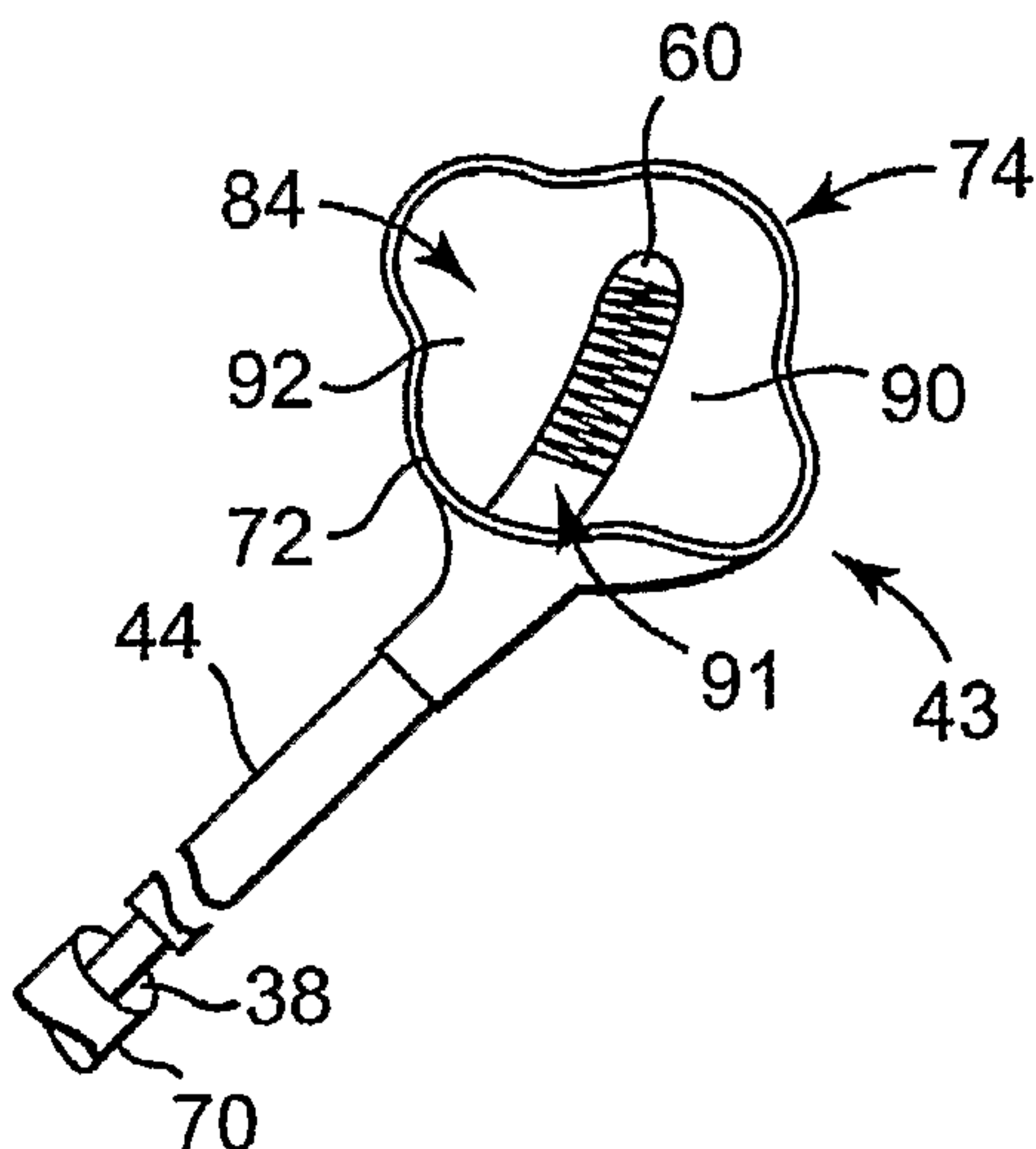
(84) Designated States (unless otherwise indicated, for every kind of regional protection available): ARIPO (BW, GH, GM, KE, LS, MW, MZ, NA, SD, SL, SZ, TZ, UG, ZM, ZW), Eurasian (AM, AZ, BY, KG, KZ, MD, RU, TJ, TM), European (AT, BE, BG, CH, CY, CZ, DE, DK, EE, ES, FI, FR, GB, GR, HU, IE, IS, IT, LT, LU, MC, NL, PL, PT, RO, SE, SI, SK, TR), OAPI (BF, BJ, CF, CG, CI, CM, GA, GN, GQ, GW, ML, MR, NE, SN, TD, TG).

**Declarations under Rule 4.17:**

- as to applicant's entitlement to apply for and be granted a patent (Rule 4.17(ii)) for the following designations AE, AG, AL, AM, AT, AU, AZ, BA, BB, BG, BR, BW, BY, BZ, CA, CH, CN, CO, CR, CU, CZ, DE, DK, DM, DZ, EC, EE, EG, ES, FI, GB, GD, GE, GH, GM, HR, HU, ID, IL, IN, IS, JP, KE, KG, KM, KP, KR, KZ, LC, LK, LR, LS, LT, LU, LV, MA, MD, MG, MK, MN, MW, MX, MZ, NA, NG, NI, NO, NZ, OM, PG, PH, PL, PT, RO, RU, SC, SD, SE, SG, SK, SL, SM, SY, TJ, TM, TN, TR, TT, TZ, UA, UG, UZ, VC, VN, YU, ZA, ZM, ZW, ARIPO patent (BW, GH, GM, KE, LS, MW, MZ, NA, SD, SL, SZ, TZ, UG, ZM, ZW), Eurasian patent (AM, AZ, BY, KG, KZ, MD, RU, TJ, TM), European patent (AT, BE, BG, CH, CY, CZ, DE, DK, EE, ES, FI, FR, GB, GR, HU, IE, IS, IT, LT, LU, MC, NL, PL, PT, RO, SE, SI, SK, TR), OAPI patent (BF, BJ, CF, CG, CI, CM, GA, GN, GQ, GW, ML, MR, NE, SN, TD, TG)
- as to the applicant's entitlement to claim the priority of the earlier application (Rule 4.17(iii)) for all designations

[Continued on next page]

(54) Title: METHOD AND DEVICES FOR TREATING ATRIAL FIBRILLATION BY MASS ABLATION



(57) Abstract: Apparatus and method for ablating target tissue including a non-linear area of tissue in the left atrium of a patient. The method can include selecting an ablation apparatus having an ablator with a tissue engagement section, penetrating a chest cavity of the patient, and identifying the target tissue. The method can also include positioning the ablation apparatus adjacent to the target tissue so that the tissue engagement section can transfer ablation energy to the target tissue. The method can further include energizing the tissue engagement section with ablation energy in order to create a footprint on the non-linear area of tissue in the left atrium and to reduce an overall mass of excitable tissue in the left atrium.

WO 2005/112812 A1

**WO 2005/112812 A1**



**Published:**

— *with international search report*

*For two-letter codes and other abbreviations, refer to the "Guidance Notes on Codes and Abbreviations" appearing at the beginning of each regular issue of the PCT Gazette.*



**METHOD AND DEVICES FOR TREATING ATRIAL FIBRILLATION BY  
MASS ABLATION**

**RELATED APPLICATIONS**

[0001] This application claims the benefit of the filing date of United States Provisional Patent Application No. 60/571,182 filed on May 14, 2004, which is incorporated herein by reference in its entirety.

5

**FIELD OF THE INVENTION**

[0002] The present invention relates to tools and procedures generally and relates more particularly to the use of ablation to reduce the mass of excitable tissue of the left atrium to prevent and treat atrial fibrillation or other medical conditions.

**BACKGROUND**

[0003] Focal triggers initiating atrial fibrillation are thought to frequently arise from the pulmonary veins and their ostia. Surgeons have used the technique of modifying the substrate of the heart in these areas to prevent the propagation of the arrhythmia. In some patients with chronic atrial fibrillation, the Cox/MAZE III procedure has been employed. This procedure controls propagation of the depolarization wavefronts in the right and left atria by means of surgical incisions through the walls of the right and left atria. The incisions create blind or dead end conduction pathways, which prevent re-entrant atrial tachycardias from occurring.

[0004] While the Cox/MAZE procedure is successful in treating atrial fibrillation, the procedure is quite complex and is currently practiced by only a few very skilled cardiac surgeons in conjunction with other open-heart procedures. The procedure also is quite traumatic to the heart, as in essence, the right and left atria are cut into pieces and sewed back together, to define lines of lesion across which the depolarization wavefronts will not propagate. Still today, the Cox/MAZE procedure is done with traditional cut and sew techniques.

[0005] The market is demanding quicker, safer and less invasive approaches. As a result, there has been much recent research and evaluation of mechanisms to

25

encircle and isolate the pulmonary veins and replicate the incisions of the MAZE operation. Companies are developing ablation techniques that heat (or cool) or chemically destroy the underlying tissue along these lines.

[0006] It has been suggested that procedures similar to the MAZE procedure could be instead, performed by means of electrosurgical ablation, for example, by applying radio frequency energy to internal or external surfaces of the atria to create lesions across which the depolarization wavefronts will not propagate. Such procedures are disclosed in United States Patent No. 5,895,417, issued to Pomeranz, et al. ("the Pomeranz '417 patent"); United States Patent No. 5,575,766, issued to Swartz, et al. ("the Swartz '766 patent"); United States Patent No. 6,032,077, issued to Pomeranz ("the Pomeranz '077 patent"); United States Patent No. 6,142,994, issued to Swanson, et al. ("the Swanson '994 patent"); and United States Patent No. 5,871,523, issued to Fleischman, et al. ("the Fleischman '523 patent"), all incorporated herein by reference in their entireties.

[0007] The Pomeranz '417 patent discloses an apparatus for ablating tissue by making linear lesions within the chamber of a patient's heart by application of a plurality of spaced electrodes along an elongate member. The Schwartz '766 patent discloses a process for treating atrial arrhythmia by creating discrete ablation tracks within both the left and right atrium. The Pomeranz '077 patent discloses an ablation catheter that is electrically connected to tissue to be ablated by a foam on the electrodes that is soaked in saline. The foam in the Pomeranz '077 patent acts as a conductive fluid to allow energy from the electrode to ablate the contacted tissue. The Swanson '994 patent discloses a surgical method and apparatus for positioning an element in the body of a patient for diagnosis or therapy. The apparatus in the Swanson '994 patent may be a catheter or a probe having a shaft with a lumen extending there through. The Fleischman '523 patent discloses a helically-wound emitter on an element with a insulating sheath movable over the emitter.

[0008] Various types of electrophysiology devices are used for ablating tissue. Typically, such devices include a conductive tip or blade that serves as one electrode in an electrical circuit that is completed via a grounding electrode coupled to the



patient. The contact point is small or linear to create lesions to form linear tracks of ablated tissue. A power source creates high levels of electrical energy between the two electrodes causing the tissue to heat to a sufficient level to denature proteins within the tissue and cause cell death. In order for such procedures to be effective, it is desirable that the electrosurgically-created lesions are continuous along their length and extend completely through the tissue of the heart.

[0009] Manufacturers have developed catheters that have a linear array of electrodes along a long axis (e.g., the Amazr, MECCA, and Revelation catheters). The surgeon positions the catheter and electrodes in contact with the tissue and either individually or sequentially applies energy to each electrode. Additionally, catheters that incorporate an electrode that is energized and moves along its length have been proposed, such as the Flex-10 from AFx, Inc., of 47929 Fremont Aye, Fremont, CA 94538.

[0010] Surgeons have also been able to create linear lesions on the heart using applications of the same techniques. For example, Kottkamp, et. al. in an article entitled "Intraoperative Radio Frequency Ablation of Chronic Atrial Fibrillation: A Left Atrial Curative Approach by Elimination of Anatomic 'Anchor' Reentrant Circuits," Journal of Cardiovascular Electrophysiology, 10:772-780 (1999), describe a hand-held device that creates a series of spot or short (less than 1 cm) linear lesions. Other investigators have used long, linear unipolar probes to create somewhat longer lesions. Still others have used multi-electrode linear catheters, similar to those described above to create a series of ablations that net a linear lesion.

[0011] The focus of most investigators has been to isolate the pulmonary veins. There is growing research that suggests this may not be necessary in the prevention and cure of atrial fibrillation, as discussed in the article by G. Stabile, P. Turco, V. La Rocca, P. Nocerino, E. Stabile, and A. De Simone entitled "Is Pulmonary Vein Isolation Necessary for Curing Atrial Fibrillation?," Circulation, 108:657-660 (2003). Rather than focusing on only isolating the pulmonary veins, reduction in the overall volume of excitable tissue in the left atrium is sufficient to prevent atrial fibrillation. The general concept is to ablate a large enough nonlinear

area of the left atrium to prevent re-entrant waves and the propagation of atrial fibrillation.

#### SUMMARY OF THE INVENTION

[0012] Some embodiments of the invention provide a method of ablating  
5 target tissue including a non-linear area of tissue in the left atrium of a patient. The  
method can include selecting an ablation apparatus having an ablator or ablation  
member with a tissue engagement section, penetrating a chest cavity of the patient,  
and identifying the target tissue. The method can also include positioning the ablation  
apparatus adjacent to the target tissue so that the tissue engagement section can  
10 transfer ablation energy to the target tissue. The method can further include  
energizing the tissue engagement section with ablation energy in order to create a  
footprint on the non-linear area of tissue in the left atrium and to reduce an overall  
mass of excitable tissue in the left atrium.

[0013] In some embodiments, an ablation apparatus can include an insertion  
15 tool having a proximal end, a distal end, and a lumen. The ablation apparatus can  
include an ablator or ablation member having a conductor and a tissue engagement  
portion. The conductor can include a source end extending from the proximal end of  
the insertion tool and a delivery end coupled to the tissue engagement portion. The  
ablator can be removably inserted in the lumen. The ablation apparatus can also  
20 include an energy source connected to the conductor. The insertion tool can be  
inserted into a patient so that the distal end is adjacent the target tissue. The  
conductor can urge the ablator out of the lumen to engage the target tissue. Energy  
can be conducted from the energy source to the ablator to create a footprint on the  
target tissue to reduce an overall mass of excitable tissue.

#### 25 BRIEF DESCRIPTION OF THE DRAWINGS

[0014] FIG. 1 is an illustration of a posteroinferior view of the human heart  
removed from the chest cavity.

[0015] FIG. 2 is an illustration of a cross-section of the human heart showing  
the left atrium and the ostia leading to the pulmonary veins.



- [0016] FIG. 3 is a schematic illustration of an ablation apparatus according to one embodiment of the invention shown being applied to a patient.
- [0017] FIG. 4 is a top view of an ablation apparatus according to another embodiment of the invention with an ablator on an insulated balloon.
- 5 [0018] FIG. 4A is a cross-sectional view along the line 4A-4A of FIG. 4.
- [0019] FIG. 4B is a partial perspective view of a distal end of an insertion tool having the ablator of FIG. 4 removably inserted therein.
- [0020] FIG. 5 is a top view of an ablation apparatus according to another embodiment of the invention with an ablator as a patch.
- 10 [0021] FIG. 5A is a cross-sectional view of the ablation apparatus along line 5A-5A of FIG. 5.
- [0022] FIG. 6 is a top view of an ablation apparatus according to another embodiment of the invention with an ablator as a contoured patch.
- [0023] FIG. 7 is a perspective view of an ablation apparatus according to  
15 another embodiment of the invention with an ablator as a bipolar electrode.
- [0024] FIG. 8 is a perspective view of an ablation apparatus according to another embodiment of the invention with a suction tent having a wiper.
- [0025] FIG. 9 is a perspective view of an ablation apparatus according to another embodiment of the invention with an ablator as an adhesive tongue electrode.
- 20 [0026] FIG. 10 is a perspective view of an ablation apparatus according to another embodiment of the invention with a head having a cauterizing chemical applicator.
- [0027] FIG. 11 is a top view and an end view of an ablation apparatus  
25 according to another embodiment of the invention with a rolled electrode for insertion in a catheter or other delivery tool.



[0028] FIG. 12 is a side view of an ablation apparatus according to another embodiment of the invention with a web ablator.

[0029] FIGS. 13A and 13B are perspective views of an ablation apparatus according to another embodiment of the invention having an expandable mesh with electrodes.

[0030] FIG. 14 is a side view of an ablation apparatus according to another embodiment of the invention with a contoured ablator for ablating adjacent to the pulmonary veins.

[0031] FIG. 15 is a top view of an ablation apparatus according to another embodiment of the invention with an ablator as a contoured patch.

[0032] FIG. 16 is a top view of an ablation apparatus according to another embodiment of the invention with a rolled electrode for insertion in a catheter or other delivery tool.

#### DETAILED DESCRIPTION

[0033] Before any embodiments of the invention are explained in detail, it is to be understood that the invention is not limited in its application to the details of construction and the arrangement of components set forth in the following description or illustrated in the following drawings. The invention is capable of other embodiments and of being practiced or of being carried out in various ways. Also, it is to be understood that the phraseology and terminology used herein is for the purpose of description and should not be regarded as limited. The use of "including," "comprising" or "having" and variations thereof herein is meant to encompass the items listed thereafter and equivalents thereof as well as additional items. The terms "mounted," "connected" and "coupled" are used broadly and encompass both direct and indirect mounting, connecting and coupling. Further, "connected" and "coupled" are not restricted to physical or mechanical connections or couplings, and can include electrical connections or couplings, whether direct or indirect.

[0034] Some embodiments of the invention provide a method and apparatus for reducing the mass of the viable tissue (e.g., by rendering the mass of tissue non-contractile, non-viable, or unable to propagate an action potential) in the left atrium of the heart to prevent or cure atrial fibrillation. Some embodiments of the invention can include preventing reentry of depolarizing wavefront signals by ablating a large area of the left atrium. Furthermore, some embodiments of the invention can substantially prevent the sustenance of atrial fibrillation.

[0035] Embodiments of the invention can provide an ablation apparatus used to conduct ablating energy to a locale of contacted or non-contacted and possibly surrounding tissue with the intent to ablate an entire area, while not harming neighboring tissue. The ablation apparatus can include an electrode having a footprint of a dimension designed to cover a predetermined region of tissue in the left atrium.

[0036] According to some embodiments of the invention, an ablation apparatus can be used to ablate a non-linear area of the tissue in the left atrium *en masse*. This method can be performed by endocardial positioning of an ablation device in the left atrium either via a trans-atrial septal puncture or retrograde through the arterial system. Alternatively, embodiments of the invention can provide a method of ablating tissue in the left atrium in a predefined area by inserting an ablating apparatus using an epicardial approach with access to the posterior left atrium through the pericardial space, either by a sub-xiphoid or inter-costal incision.

[0037] Some embodiments of the invention provide a method of ablating tissue using a large footprint ablation electrode for the control, prevention, and cure of atrial fibrillation. The method can include ablating a predefined area of tissue in the left atrium, while protecting other areas of the heart, lungs, and esophagus using directional energy delivery, insulation, or standoffs to space the ablation apparatus from protected areas. The method of ablating the heart tissue can include using a trans-venous catheter from the inside of the heart to deliver the ablation apparatus. Location and imaging techniques such as echogram, sonogram, magnetic resonance imaging, ultrasound, X-ray, sensors or transmitters on the ablation device, or other



mapping technology can allow for proper placement to minimize damage to surrounding tissue.

[0038] Some embodiments of the invention include a locatable ablation apparatus having a predefined footprint that can be delivered through an incision in the chest wall in order to ablate by trans-myocardial engagement with a bipolar electrode. The ablation apparatus can use any of suitable method and/or procedure with electro-surgical devices or other types of ablation devices (e.g., thermal ablation, micro-wave ablation, cryogenic ablation, ultrasound ablation, etc.) to ablate tissue in the left atrium to reduce the mass of excitable tissue therein.

[0039] The apparatuses and methods of some embodiments of the invention are designed to reduce the overall excitable mass of the left atrium and to reduce or cure atrial fibrillation (AF). Some embodiments of the invention use radio frequency energy to create heat and ablate an area of tissue. However, other embodiments of the invention may include additional or alternative energy sources, such as microwave, cryogenic, ultrasound, laser, thermal, etc. Also, some embodiments of the invention can be used for creating ablation lesions in other areas of the heart, such as the ventricles.

[0040] FIG. 1 illustrates the human heart 10 from a posteroinferior view. The left atrium 12 includes an external surface 14 of an area target tissue 15, which includes the area of tissue to be ablated. In some embodiments, the target tissue 15 can be defined as the entire left atrial posterior wall tissue extending around, but not including, the pulmonary veins. As shown in FIG. 1, the target tissue 15 can be generally spaced from the pulmonary veins 16 to prevent damage to the pulmonary veins 16.

[0041] As shown in FIG. 2, an inner chamber 22 of the left atrium 12 includes an internal surface 24 of the target tissue 15. The pulmonary veins 16 themselves are generally not included in the target tissue 15 due to concern over vein stenosis. The internal surface 24 of the target tissue 15 may be defined as the entire left atrial posterior wall tissue extending into the ostial regions surrounding the pulmonary veins 16, but not extending over into the lumen of the pulmonary veins, extending to

near the mitral valve annulus. There is interest in creating conduction block in the area between one or both of the right inferior pulmonary vein and the mitral valve annulus. Tissue to be protected can include all tissue in the patient not defined as the target tissue 15. Tissue to be protected can be isolated to prevent damage. The target  
5 tissue 15 can be spaced from the ostia of the pulmonary veins 16, but may extend to areas surrounding the pulmonary vein ostia as well.

[0042] FIG. 3 illustrates an ablation apparatus 30 according to one embodiment of the invention for ablating the target tissue 15. The ablation apparatus 30 can include or be used in conjunction with an insertion tool 32, such as a trocar, an  
10 endoscopy port, a catheter, etc. The insertion tool 32 can include a distal end 34 and a proximal end 36. The ablation apparatus 30 can also include a lumen 38 that can extend through the insertion tool 32 and can open at the distal end 34 and/or the proximal end 36 of the insertion tool 32. The ablation apparatus 30 can further include an ablator 43 that can extend from the distal end 34 of the insertion tool 32.  
15 The ablator 43 can be inserted in the lumen 38 for delivery through an incision 40 in the patient 42. A conductor 44 can extend through the lumen 38 to connect the ablator 43 to a power source 46. The power source 46 can be a source of ablation energy, such as radio frequency energy. Other forms of ablative methods and energy sources can be used with the ablator 43. Other forms of ablation techniques include,  
20 but are not limited to, microwave, ultrasound, heat, cyrogenic, radiation, and chemical ablation.

[0043] Proper positioning of the ablator 43 on the targeted tissue 15 can be performed by any suitable means, such as direct visualization, fluoroscopic X-ray visualization, ultrasound positron emission tomography, fluoroscopy, intra-cardiac  
25 echo, trans-esophageal echo, magnetic resonance imaging, computerized tomography, or by endoscopic imaging. As shown in FIG. 3, a mapping tool 48 can include a sensor 50 connected to a display 52 to represent or visualize the position of the ablator 43 with respect to the target tissue 15. An input device, such as a toggle stick 54 or a pointer pen 56, can be used to identify the target tissue 15 on the heart 10.



[0044] The ablator 34 can include a tissue engagement section 60 (as shown in FIGS. 4-6), which can include a footprint that allows the tissue engagement section 60 to ablate a predefined area with each energization.

[0045] As shown in FIG. 4, the ablator 43 can include a balloon 58 having a tissue engagement section 60 with a footprint for endocardial or epicardial application. The footprint can be of a size and shape to conform to the individual patient requirements. The balloon 58 may include an inflator tube 62 positioned in the insertion tool 32. The inflator tube 62 can be connected to an inflation source 64 for inflating the balloon 58 with air, CO<sup>2</sup>, saline, etc. An insulator 66 on the balloon 58 can protect adjacent tissue from the energy in the ablator 43, while ablating the target tissue 15 bearing against the footprint of the tissue engagement section 60. Additional insulation can be achieved by the saline or gas in the balloon 58. The insertion tool 32 can be flexible or rigid to help the surgeon manipulate the position of the balloon 58 to bring the tissue engagement section 60 in contact with the target tissue 15. The inflation source 64 can direct liquid or gas through the inflator tube 62 to inflate the balloon 58. The balloon 58 can expand to cause the tissue engagement section 60 to bear against the target tissue 15. In some embodiments, as shown in FIG. 4, bowing struts 67 can be deployed within the left atrium 12 to push the ablator 43 into contact with the left atrial posterior wall. When deployed in the pericardial space, the balloon 58 may be inflated to force contact of the tissue engagement section 60 with the epicardial target tissue 15.

[0046] In some embodiments, the balloon 58 can include a conducting surface that acts as a tissue engagement section 60. A collapsed balloon 58 can be inserted into the left atrium 12 or into the pericardial space surrounding the epicardial surface of the target tissue 15. In one embodiment, the balloon 58 can then be inflated with saline from the inflation source 64 and oriented such that a thermally-transmissive, tissue engagement section 60 of the balloon 58 can be positioned against the posterior left atrium and an insulated portion of the balloon 58 can be positioned against the anterior left atrium. The saline can be heated by electrical current supplied by power source 46 to a temperature between 50 degrees Celsius and 85 degrees Celsius, and in some embodiments, between 55 degrees Celsius and 65 degrees Celsius. At these

temperatures, the cells in the target area 15 generally die without collagen shrinkage. Alternatively, the balloon 58 can be cooled with cryogenic technology to freeze the atrial tissue and ablate the target tissue 15. Generally, temperatures for cryogenic therapy must be less than negative 20 degrees Celsius to negative 40 degrees Celsius.

5 [0047] FIG. 4 illustrates a cross section of the balloon 58 with the insulator 66 surrounding the ablator 43. The ablator 43 can include one or more ablating elements 68 on the tissue engagement section 60 for transferring the energy of the power source 46 to the target tissue 15. Ablating elements 68 may comprise one or more electrodes, ultrasound transducers, microwave antennae, cryogenic elements, chemical elements and/or radioactive elements, for example. Insertion of the balloon 10 58 into the left atrium 12 allows the balloon 58 to be manipulated during inflation to bring the ablating elements 68 of the tissue engagement section 60 to bear against the target tissue 15 and to space the ablating elements 68 from the tissue to be protected. The insulator 66 can protect adjacent tissue not within the area of the target tissue 15.

15 [0048] The ablator 43 can be delivered to the desired location in the patient using the insertion tool 32, such as a catheter 70, as shown in FIG. 4B. The footprint of the ablator 43 can be configured for any patient anatomy and/or any ablation pattern desired. The collapsed balloon 58 of the ablator 43 can be removably inserted through the distal end 34 of the catheter 70, so that the conductor 44 extends through 20 the insertion tool 32, as shown in FIG. 4B. The catheter 70 can be inserted into the patient 42 (as described with respect to FIG. 3) to position the distal end 34 adjacent the target tissue 15. The conductor 44 can be used to push the ablator 43 out of the lumen 38 to a position extending from the distal end 34, as shown in FIG. 4.

[0049] FIGS. 5 and 5A illustrate an embodiment of a circular ablator 43. In 25 other embodiments, the ablator 43 can be elliptical, oval, etc. The circular ablator 43 can include a tissue engagement surface 60 and an outside skirt 72. The outside skirt 72 can be used as a stand-off to space the tissue engagement surface 60 from delicate tissue, such as the pulmonary veins 16. The circular ablator 43 can include one or more ablating elements 68 on the tissue engagement surface 60 and an insulation 30 layer 66 on the opposite surface, as shown in FIG. 5A. The ablating elements 68 can



be positioned in a helical or circular pattern. The outside skirt 72 can be constructed of a soft, heat-insulating material, such as silicone or other elastomeric material. The outside skirt 72 can include an outer edge 74 constructed of a resilient material to positively space the ablating elements 68 from the tissue to be protected.

5 [0050] The circular ablator 43 can be used epicardially by insertion within the pericardial space adjacent the posterior left atrium. In one embodiment, the circular ablator 43 can alternatively include an uncoiling spiral configuration. The uncoiling spiral can be positioned through a sheath 32, and when advanced beyond the sheath 32, can uncoil to take the desired shape. Pre-formed shape memory or superelastic  
10 alloys, such as NiTi, can be used to ensure that the spiral uncoils into the desired shape.

[0051] In another embodiment, two circular ablaters 43 can be used in a bipolar arrangement. One ablator 43 can be on the external surface 14 of the target tissue 15 and another ablator 43 can be positioned on the internal surface 24 of the  
15 target tissue 15 in the left atrium 12. The bipolar circular ablator 43 can also be positioned using an uncoiling spiral configuration. The uncoiling spiral can be positioned through a sheath 32, and when advanced beyond the sheath 32, can uncoil to take the desired shape. Pre-formed shape memory or superelastic alloys, such as NiTi, can be used to ensure that the spiral uncoils into the desired shape.

20 [0052] FIGS. 6 and 15 illustrate two embodiments of a contoured patch ablator 43 having a predefined shape with contoured edges 76. The contoured edges 76 can bear against structures in the heart, such as the pulmonary veins 16, to position the tissue engagement surface 60 against the target tissue 15. As shown in FIG. 6, ablating elements 68 can be connected to a power source 46 by the conductor 44  
25 extending through an insertion tool 32 for either epicardial or endocardial use.

[0053] FIG. 7 illustrates an ablator 43 having two ablating elements, a first ablating element 80 and a second ablating element 82. A conductor 44 may be used to connect the first and second ablating elements 80, 82 together or separately for individual control. In one embodiment, ablating elements 80, 82 may comprise  
30 electrodes, which can be energized using radio frequency energy. Ablating elements

80, 82 may be held in contact with tissue by a vacuum applied to ports 83. Alternatively, the first ablating element 80 may be a high intensity focused ultrasound (HIFU) crystal transmitter or transducer and the second ablating element 82 can be another HIFU crystal transmitter or transducer, both of which can focus ultrasound energy on the target tissue 15. Alternatively, the first and second ablating elements 80, 82 may be microwave antennae, which can deliver microwave ablation energy to the target tissue 15. The ablator 43 may be used, in some embodiments, from a location within the esophagus to focus ablation energy on the posterior left atrium of the heart.

10 [0054] FIG. 8 illustrates an ablator 43 having a skirt 73 and a deployable wiper 86 that can be placed in the patient to surround the target tissue 15. The skirt 73 can be held to the target tissue 15 by a vacuum applied to a suction chamber 84. The deployable wiper 86 can be connected to a conductor 44 and can move within the skirt 73 of the ablator 43 to rotate in an arc around a pivot point (e.g., a motor 88).  
15 The deployable wiper 86 may include one or more ablating elements. The deployable wiper 86 can sweep from side to side and/or can rotate 360 degrees and can apply energy to ablate during all or during a portion of the rotation. The skirt 73 can be collapsible to be removably inserted in a catheter 70. A resilient outer edge 74 can releasably seal onto the target tissue 15 when the vacuum is applied. An air gap  
20 between the skirt 73 and the deployable wiper 86 can protect adjacent tissue from harm by the ablation energy. Also, to aid in guiding the ablations within the skirt 73, a lumen can be provided adjacent to the conductor 44 to allow passage of a fiber optic or endoscopic catheter, which can provide visual confirmation of proper positioning of the skirt 73 and of the selected region for ablation.

25 [0055] FIG. 9 illustrates an ablator 43 including an adhesive tongue 90 having a footprint extending from a catheter 70. A skirt 72 can be used to ablate tissue within an outer edge 74. The adhesive tongue 90 can be removably attached to the target tissue 15 for directed ablation by a vacuum applied through a conductor 44. In other embodiments, contact may be facilitated with a biological compatible glue or  
30 adhesive 91 on a tissue engagement surface 60. A conductive fluid 92 can be used in a chamber 84 of the skirt 72 to translate the ablating energy to all tissue within the



outer edge 74. Alternatively, epicardial application of the adhesive tongue 90 with slow release ablation chemicals can be used to ablate tissue. The adhesive tongue 90 can also include, in some embodiments, anti-arrhythmia medications or other medications.

5 [0056] FIG. 10 illustrates an ablator 43 designed to deliver one or more ablation agents, e.g., chemical ablation agents and/or radioactive ablation agents. A conductor or conduit 44 can transfer an ablative agent through a tip 96 to come in contact with tissue within an outer edge 74 of a skirt 72. The tip 96 can be removably inserted into a catheter 70 to be positioned in the left atrium. The catheter 70 can be manipulated and rotated to cause the skirt 72 to cover the target tissue 15. An ablation agent can be introduced into a chamber 84 within the skirt 72 to ablate the target tissue 15. Following the ablation procedure, any remaining ablation agent may be removed back through tip 96. In some embodiments, tip 96 may be designed for mechanical injection and/or needle-less injection of an ablation agent into tissue. In one embodiment, the ablation agent diffuses into the tissue to be treated. Alternatively, the ablation agent is delivered via controlled slow-release delivery and/or iontophoresis techniques.

[0057] FIG. 11 illustrates an ablator 43 including a rolled ablating element 98 that can be rolled into a single roll or parallel rolls and can be removably inserted in an insertion tool 32. S-shaped memory wires 100 can unroll the rolled ablating element 98 when a conductor 44 urges the rolled ablating element 98 out of a lumen 38. The rolled ablating element 98 can be rolled for placement between the heart 10 and pericardium for epicardial ablation onto the external surface 14 of the target tissue 15. The rolled ablating element 98 can be similar to the circular and contoured embodiments shown in FIGS. 5 and 6, respectively.

[0058] FIG. 12 illustrates an ablator 43 including a webbed fan 102 having ablating elements 68a and 68b positioned in an apex 104 of each fold 106. The ablating elements 68a when positioned adjacent the target tissue 15 can be energized and the ablating elements 68b spaced from the target tissue 15 can remain non-

energized to protect tissue outside the area of target tissue 15. The webbed fan 102 can include an insulation layer on one side. The webbed fan 102 can be unfolded into a flat sheet to energize all or a portion of the ablating elements 68a, 68b. The webbed fan 102 may be compressed to be removably inserted in a lumen 38 of a catheter 70.

5 [0059] FIGS. 13A and 13B illustrate an ablator 43 with an expandable mesh with numerous ablating elements 68. The ablator 43 can be positioned in the left atrium using an insertion tool 32. Each ablating element 68 can be individually represented using a mapping tool 48 and displayed on a display 52. A conductor 44 can allow individual electrodes 68 in contact with the target tissue 15 to be energized  
10 by a power source 46 to ablate tissue. One or more sensors 50 can be positioned inside the expandable mesh to locate the target tissue 15. The ablating elements 68 on the expandable mesh that are contacting the posterior left atrium can be selected. Selection can be facilitated by electrophysiological mapping, computerized complex algorithms, imaging, individual addressing of smart ablating elements 68, or other  
15 suitable methods. The appropriate ablating elements 68 can be are energized either individually or collectively to create an area of ablated tissue on the posterior.

[0060] FIG. 14 illustrates a contoured ablator 43 with a predefined shape defined by contoured edges 76. The contoured edges 76 can bear against structures on the heart, such as the pulmonary veins 16 to position a tissue engagement surface  
20 60 against the target tissue 15. One or more ablating elements 68 can be connected to a power source (not shown) by a conductor 44.

[0061] FIG. 16 illustrates a coiled linear ablator 43 with one or more coiled ablating elements that can be deployed out of an insertion tool 32 (e.g., a sheath) to create an area for ablation. In some embodiments, the coiled linear ablator 43 can  
25 deliver energy in one direction (e.g., toward the epicardial surface of the posterior left atrium).

[0062] In some embodiments, the ablator 43 (e.g., an ablation energy transmitting member having one or more ablating elements) may be remote from the target tissue 15. For example, ultrasound energy may be focused remotely on the  
30 target tissue 15, causing ablation of the target tissue 15, while passing without



ablating through non-targeted tissue located between the targeted tissue and ablator 43. The location of the energy focus on the target tissue 15 can be moved throughout the region to be ablated by steering a focal point about a non-linear area to be ablated. A steering mechanism can be manual (e.g., by physically moving an ultrasound  
5 transducer relative to the tissue) or electrical (e.g., by using phased arrays of ultrasound transducers or by otherwise modifying the ultrasound focal zone).

[0063] Some embodiments of the invention are effective at terminating atrial fibrillation, yet can be performed more safely than some conventional methods. Some  
10 embodiments of the invention can perform ablations more quickly than some conventional methods. Some embodiments of the invention can also be used to amputate, ligate, staple, etc. the left atrial appendage (LAA) of the heart — a major source of clots and strokes in the population. Some embodiments of the invention result in less trauma to the patient and less chance of accidentally damaging the heart and surrounding structures. Some embodiments of the invention can minimize the  
15 size of the incision required to insert the ablation apparatus 30 and/or the ablator 43 through the chest wall. Some embodiments of the invention can eliminate the need for contiguous, linear lesions to treat atrial fibrillation. Some embodiments of the invention can allow the surgeon to create lesions in the heart from the epicardial surface of the beating heart. Some embodiments of the invention can be practiced via  
20 transvenous catheters from the inside of the heart.

[0064] Various additional features and advantages of the invention are set forth in the following claims.

## CLAIMS

1. A method of ablating target tissue including a non-linear area of tissue in a left atrium of a patient, the method comprising:
  - 5 selecting an ablation apparatus having an ablator with a tissue engagement section;
  - penetrating a chest cavity of the patient;
  - identifying the target tissue;
  - positioning the ablation apparatus adjacent to the target tissue so that the tissue engagement section can transfer ablation energy to the target tissue; and
  - 10 energizing the tissue engagement section with ablation energy in order to create a footprint on the non-linear area of tissue in the left atrium and to reduce an overall mass of excitable tissue in the left atrium.
2. The method of claim 1 and further comprising choosing an ablation apparatus using at least one of radio frequency energy, thermal energy, cryogenic energy,  
15 chemical energy, pharmacological energy, ultrasound energy, microwave energy, laser energy, and radiation energy.
3. The method of claim 1 and further comprising choosing an ablation apparatus including at least one of a balloon, a mesh, a patch, a rolled electrode, a fan, a bipolar electrode, a wiper, and a crystal transmitter.
- 20 4. The method of claim 1 and further comprising penetrating the chest cavity by entering through at least one of a sub-xiphoid incision, a sub-costal incision, a sternotomy, a thoracotomy, and a trans-venous puncture.
5. The method of claim 1 and further comprising identifying the target tissue using at least one of direct visualization, X-ray, ultrasound, magnetic resonance  
25 imaging, positron emission tomography, computerized tomography, fluoroscopy, endoscopic observation, intra cardiac echo, and transesophageal echo.



6. The method of claim 1 and further comprising placing the ablation apparatus adjacent the outside of the left atrium by an epicardial approach.
7. The method of claim 1 and further comprising placing the ablation apparatus adjacent the inside of the left atrium by an endocardial approach.
- 5 8. The method of claim 1 and further comprising placing the ablation apparatus adjacent the left atrium by a transesophageal approach.
9. The method of claim 8 and further comprising energizing the tissue engagement section with ultrasound energy.
- 10 10. The method of claim 9 and further comprising focusing the ultrasound energy on the target tissue.
11. The method of claim 1 and further comprising transferring energy to a portion of the ablation apparatus at the tissue engagement section.
12. The method of claim 1 and further comprising:
- removably placing the ablation apparatus in a delivery end of an insertion tool;
- 15 positioning the insertion tool into the patient through an incision;
- directing the delivery end to a location adjacent the target tissue;
- removing the ablation apparatus from the insertion tool; and
- adjusting the ablation apparatus to bring the tissue engagement section in contact with the target tissue.
- 20 13. The method of claim 1 and further comprising affixing the tissue engagement section to the target tissue by at least one of a bio-adhesive, a vacuum, an inflatable balloon, a mechanical deflection, a magnetic field, a shape memory alloy, and a superelastic alloy.

14. The method of claim 1 and further comprising providing an insulator in the ablation apparatus to prevent damage to tissue adjacent the target tissue.

15. An ablation apparatus for ablating target tissue of a patient, the ablation apparatus comprising:

5 an insertion tool having a proximal end, a distal end, and a lumen;

an ablator including a conductor and a tissue engagement portion, the conductor having a source end extending from the proximal end of the insertion tool and a delivery end coupled to the tissue engagement portion, the ablator removably inserted in the lumen; and

10 an energy source connected to the conductor;

the insertion tool being inserted into a patient so that the distal end is adjacent the target tissue,

the conductor urging the ablator out of the lumen to engage the target tissue;

15 energy being conducted from the energy source to the ablator to create a footprint on the target tissue to reduce an overall mass of excitable tissue.

16. The ablation apparatus of claim 15 and further comprising a sensor connected to the ablator to sense the target tissue.

17. The ablation apparatus of claim 15 and further comprising a mapping tool to visualize the tissue engagement portion of the ablator.

20 18. The ablation apparatus of claim 15 wherein the insertion tool includes a catheter.

19. The ablation apparatus of claim 15 wherein the ablator includes a patch removably attachable to the target tissue, the patch including at least one of an adhesive patch, a tongue patch, a circular patch, a balloon patch, a suction patch, a chemical release patch, a rolled patch, a carbon patch, and a webbed patch.

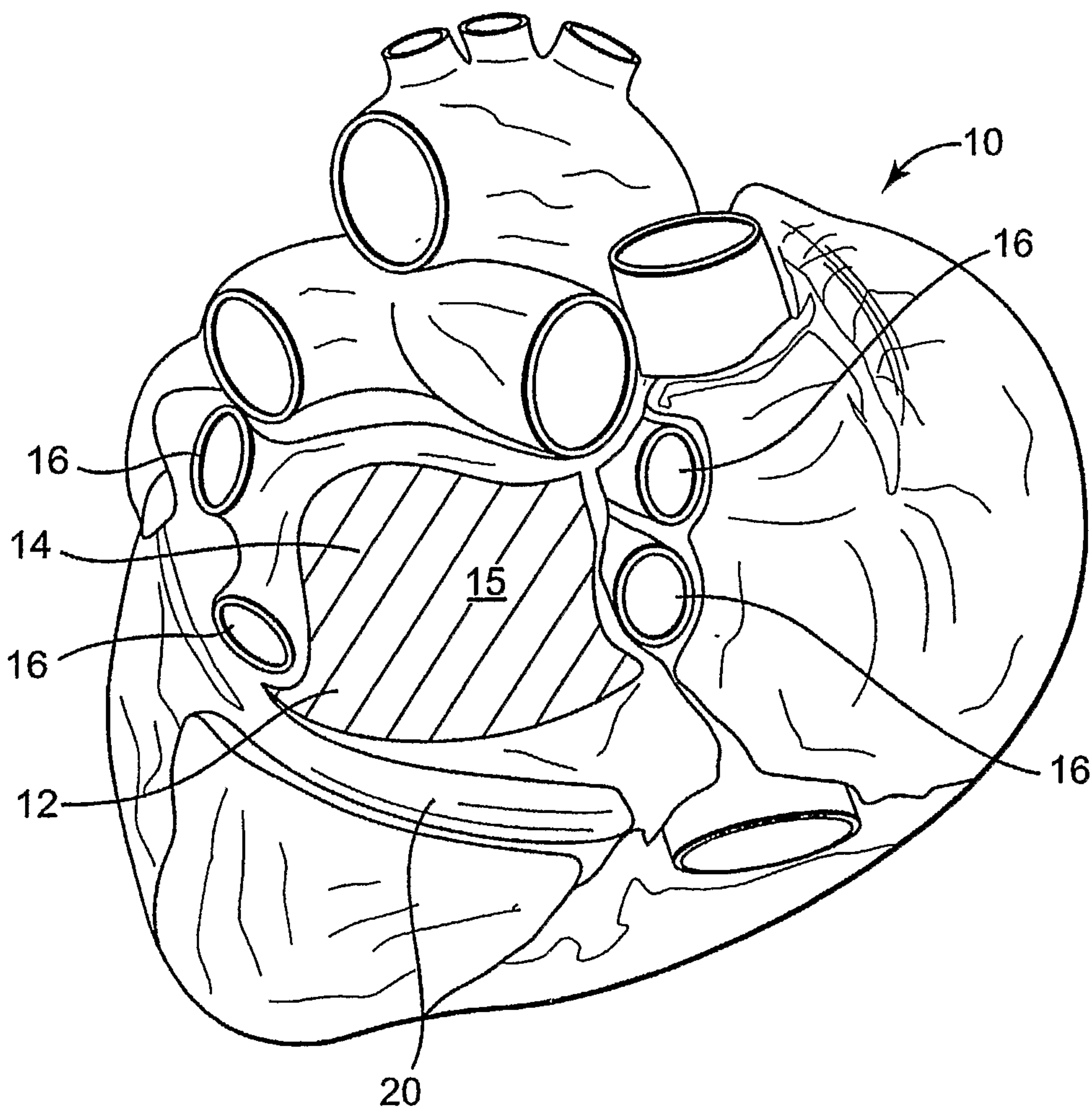
25



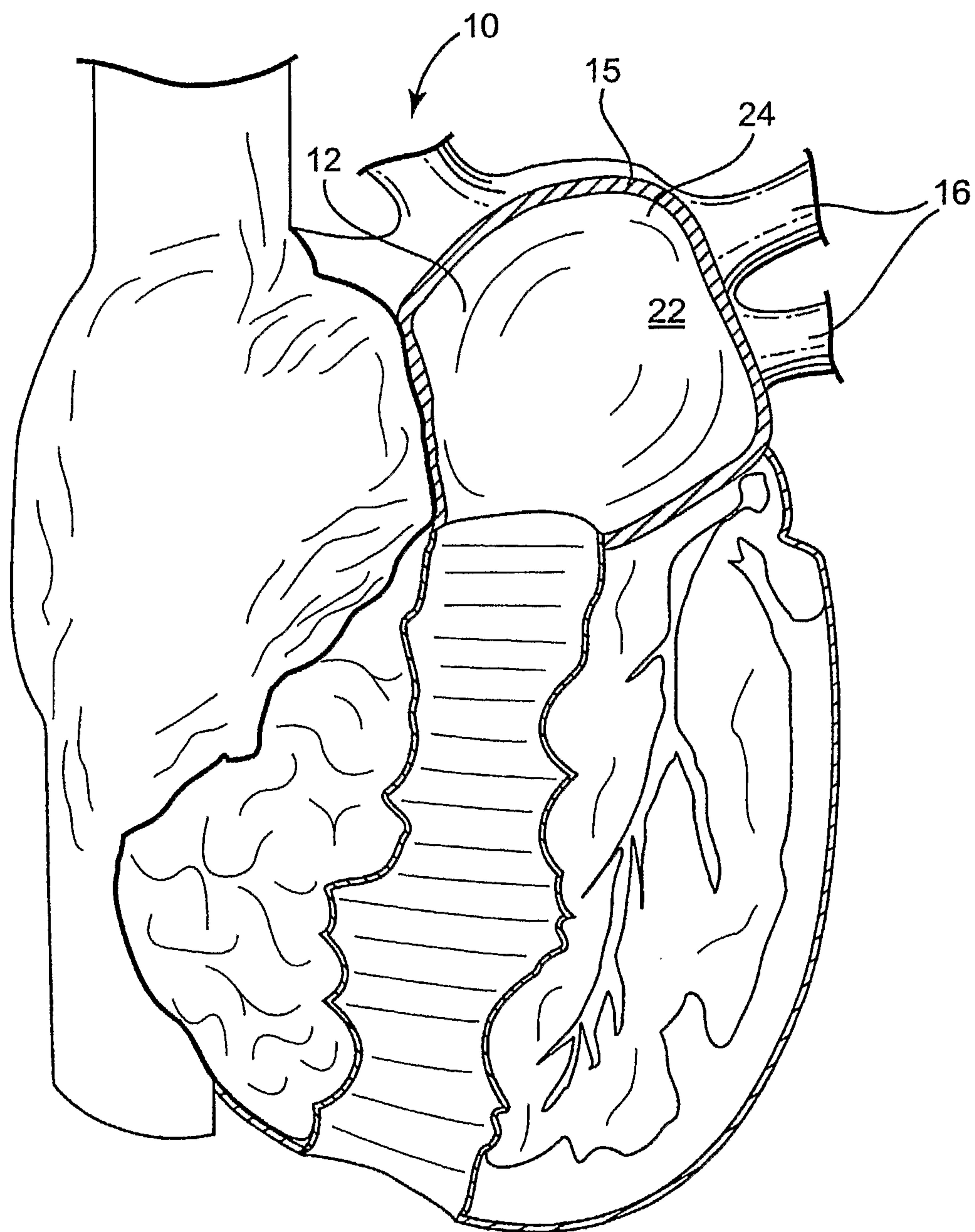
20. The ablation apparatus of claim 15 wherein the ablator includes a skirt that can suction to the target tissue, the skirt receiving fluid for conducting the energy to the target tissue.
21. The ablation apparatus of claim 20 wherein the fluid is electrically conductive.
- 5 22. The ablation apparatus of claim 20 wherein the fluid is caustic.
23. The ablation apparatus of claim 20 wherein the fluid is thermally conductive.
24. The ablation apparatus of claim 15 wherein the ablator includes a balloon, the balloon being inflatable to occupy a cavity in the patient adjacent to the target tissue, the balloon being removably stored in the distal end of the insertion tool wherein the  
10 balloon is inflated causing the balloon to emerge from the insertion tool, and the balloon being positionable to cause the tissue engagement portion to bear against the target tissue.
25. The ablation apparatus of claim 15 wherein the ablator includes a chemical delivery system.
- 15 26. The ablation apparatus of claim 25 wherein the chemical delivery system includes a delivery method of at least one of diffusion, iontophoresis, mechanical injection, needle-less injection, and controlled slow-release delivery.
27. The ablation apparatus of claim 15 wherein the ablator includes a skirt and an adhesive tongue inside the skirt, the tongue moveable within the skirt to engage the  
20 target tissue, the skirt affixing the ablator to the target tissue by a vacuum.

28. The ablation apparatus of claim 15 wherein the tissue engagement portion includes a first bipolar tissue electrode and a second bipolar tissue electrode, wherein the first bipolar tissue electrode is applied to the interior of the left atrium endocardially, wherein the second bipolar tissue electrode is applied to the exterior of the left atrium epicardially, each of the first and second bipolar tissue electrodes connected to the energy source, energy being applied from the energy source to conduct from the first bipolar tissue electrode to the second bipolar tissue electrode to render a mass of left atrium tissue located between the first and second bipolar tissue electrodes at least one of non-contractile, non-viable, and unable to propagate an action potential.



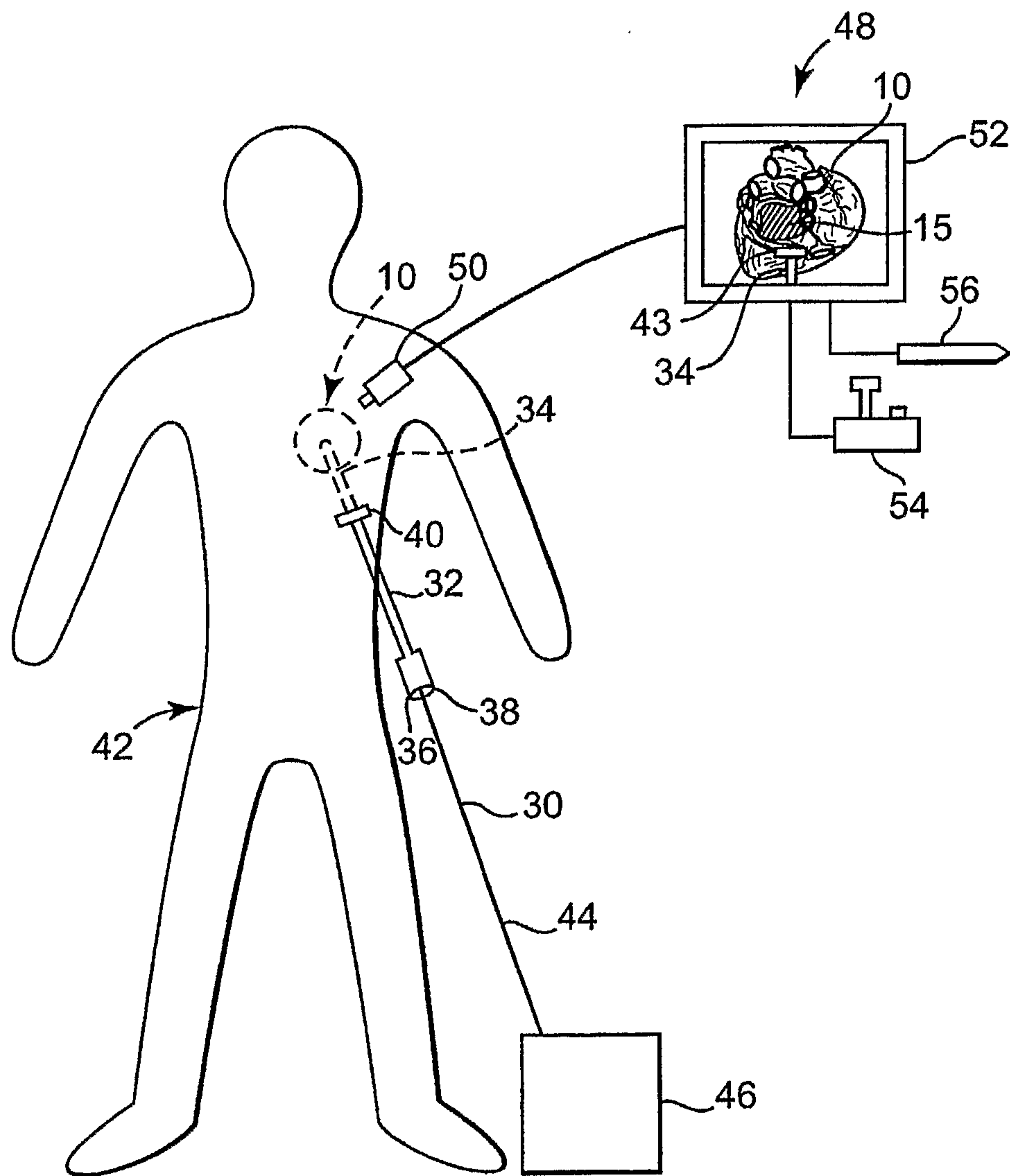


**Fig. 1**

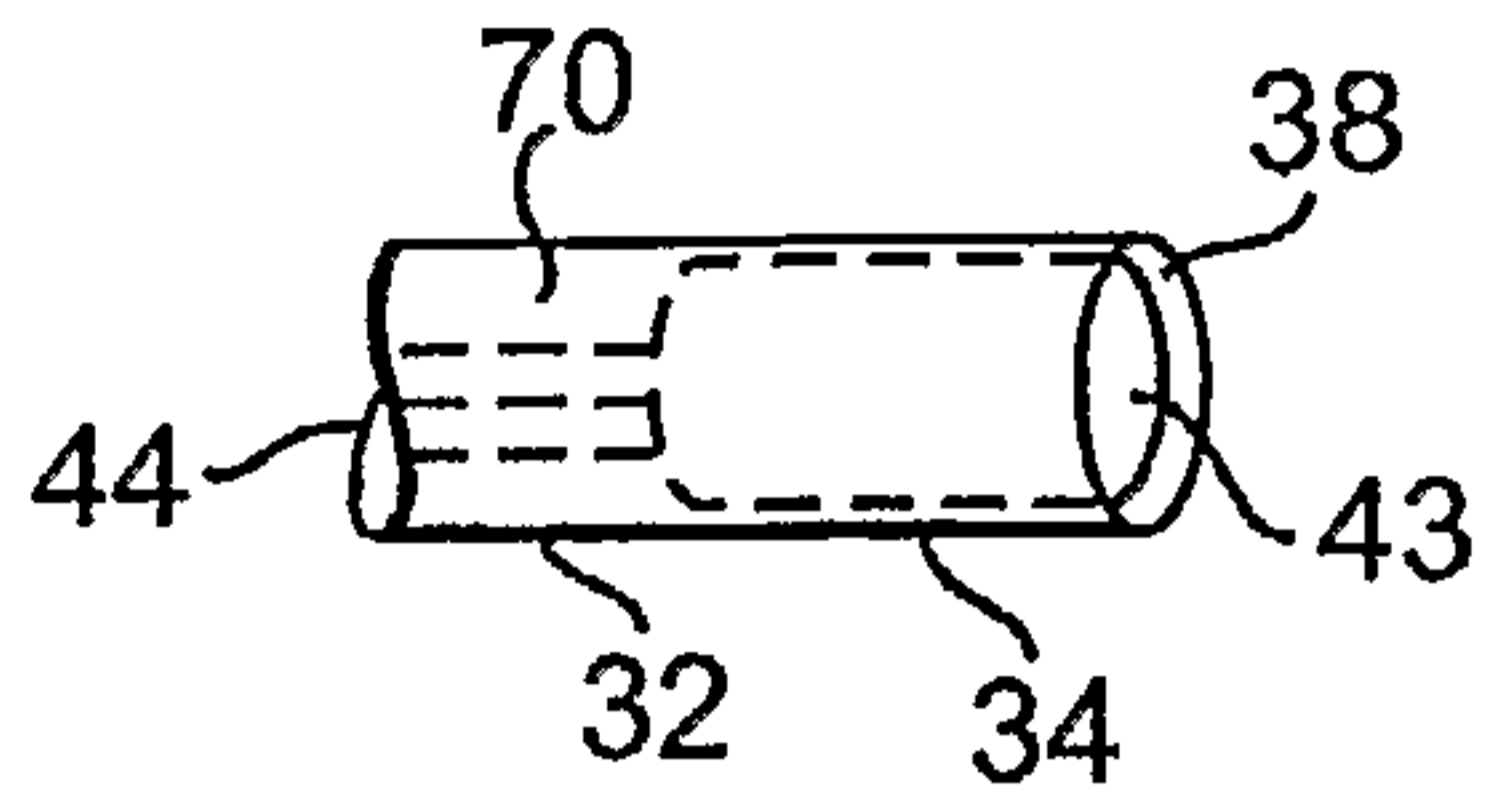


**Fig. 2**

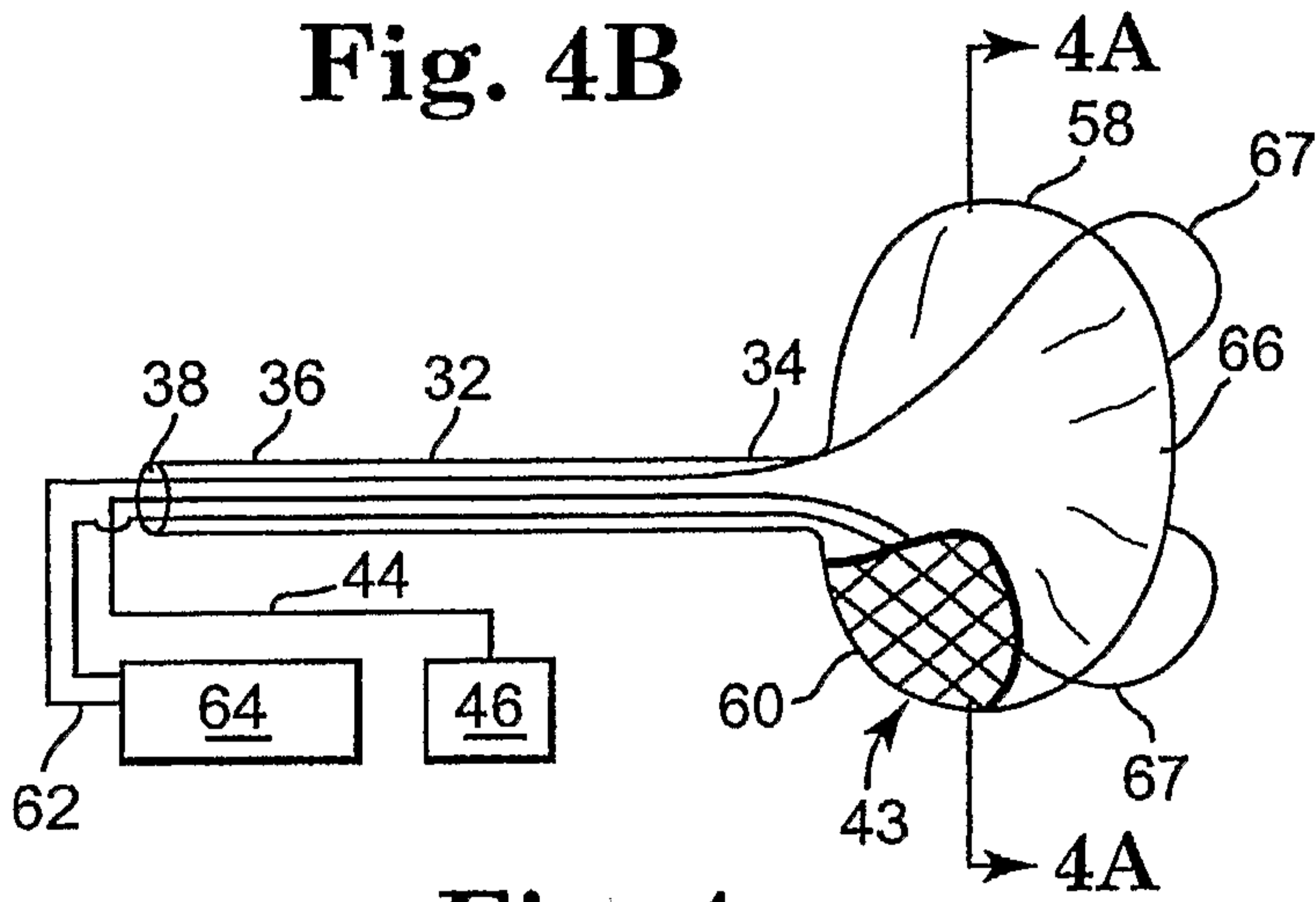




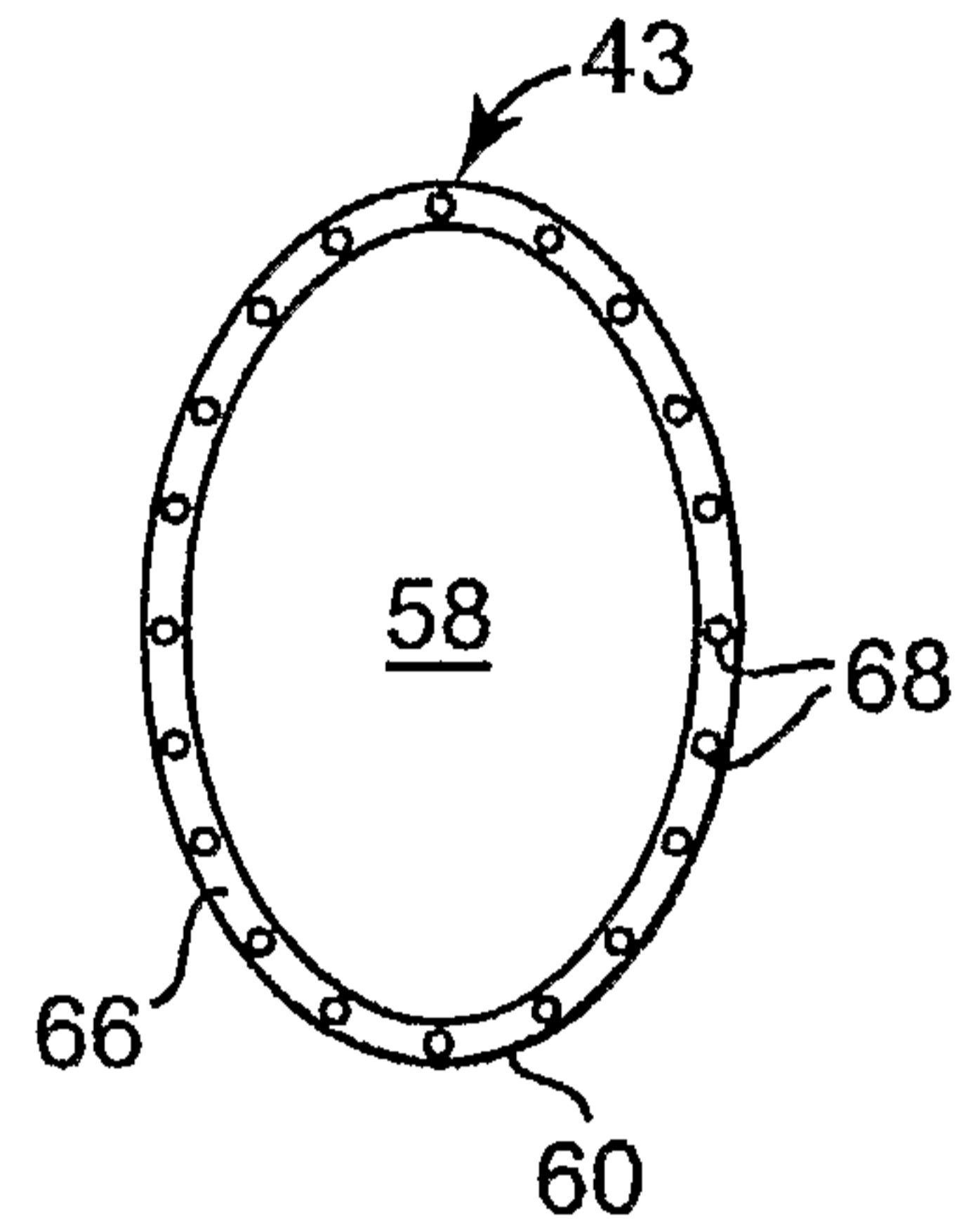
**Fig. 3**



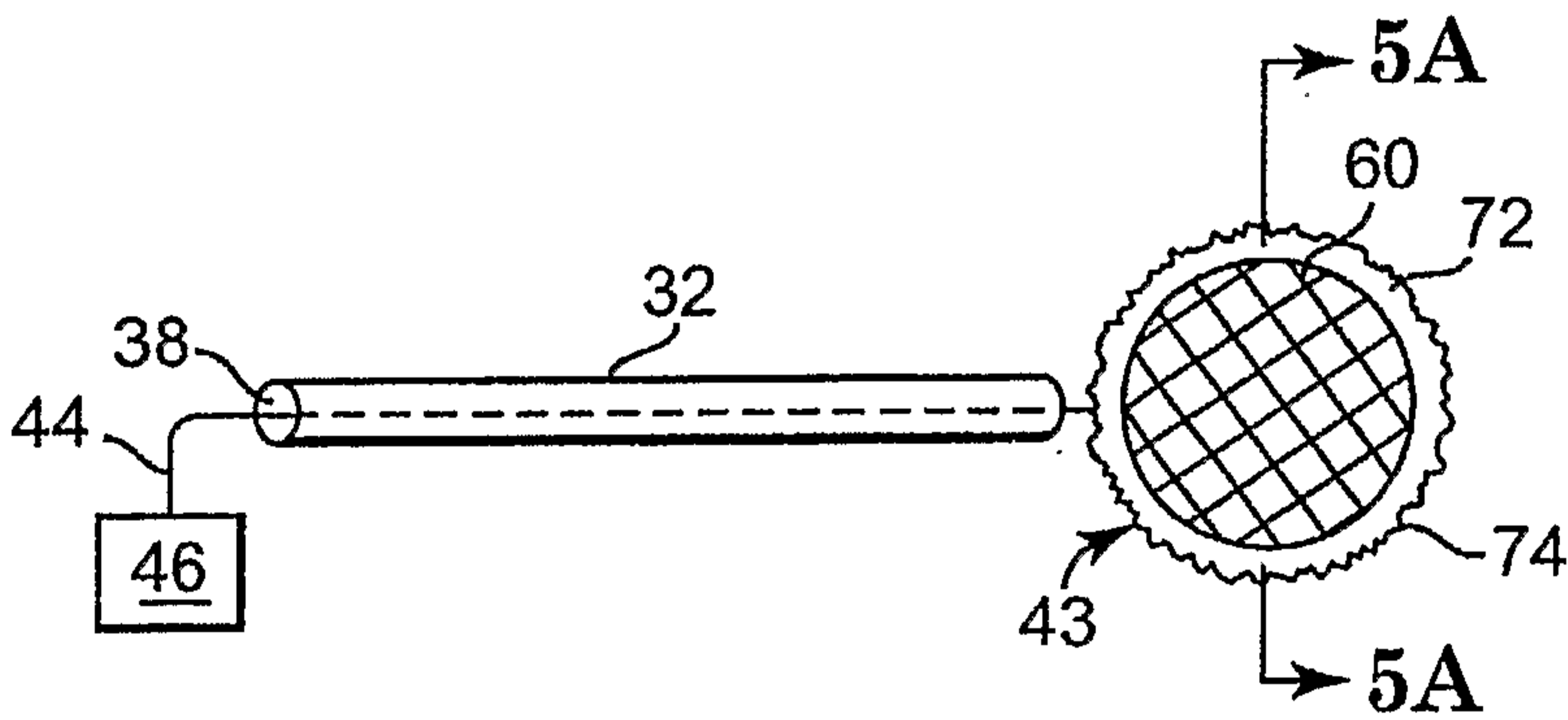
**Fig. 4B**



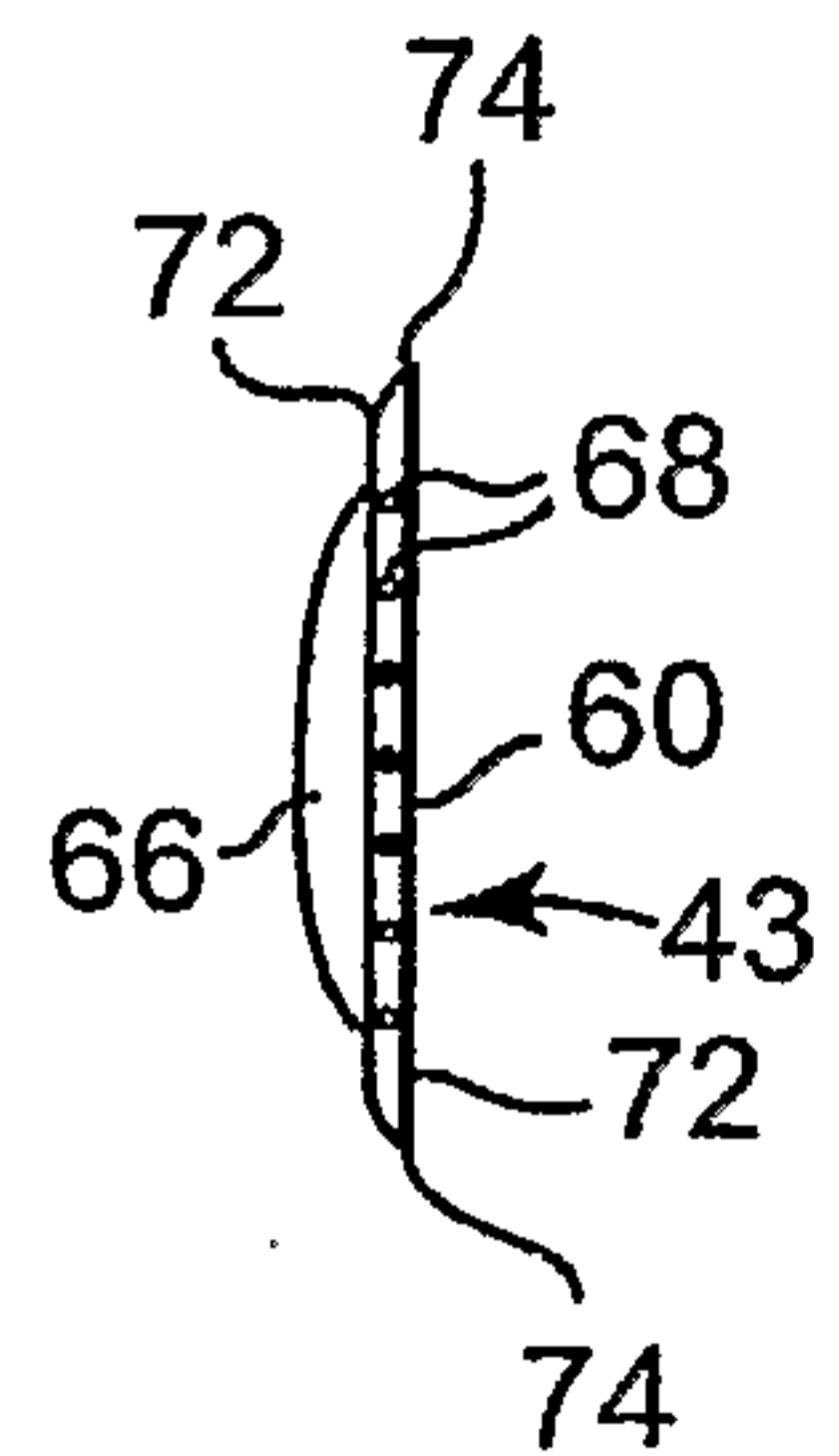
**Fig. 4**



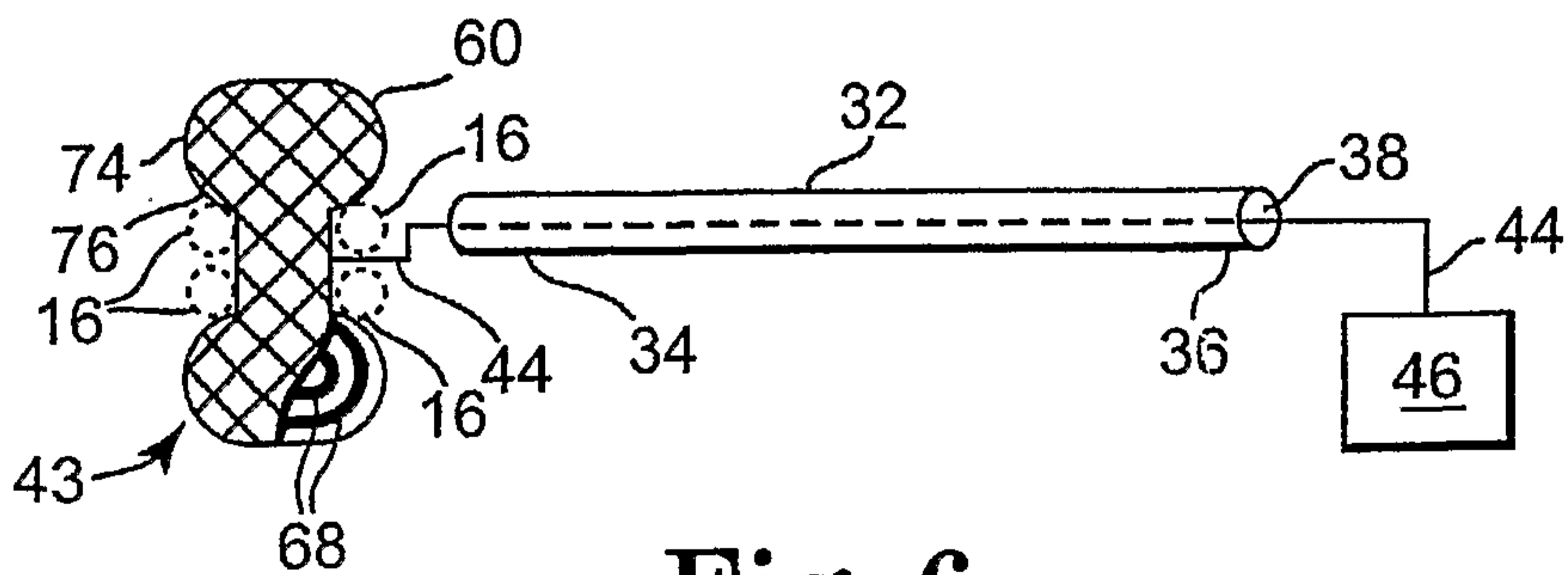
**Fig. 4A**



**Fig. 5**

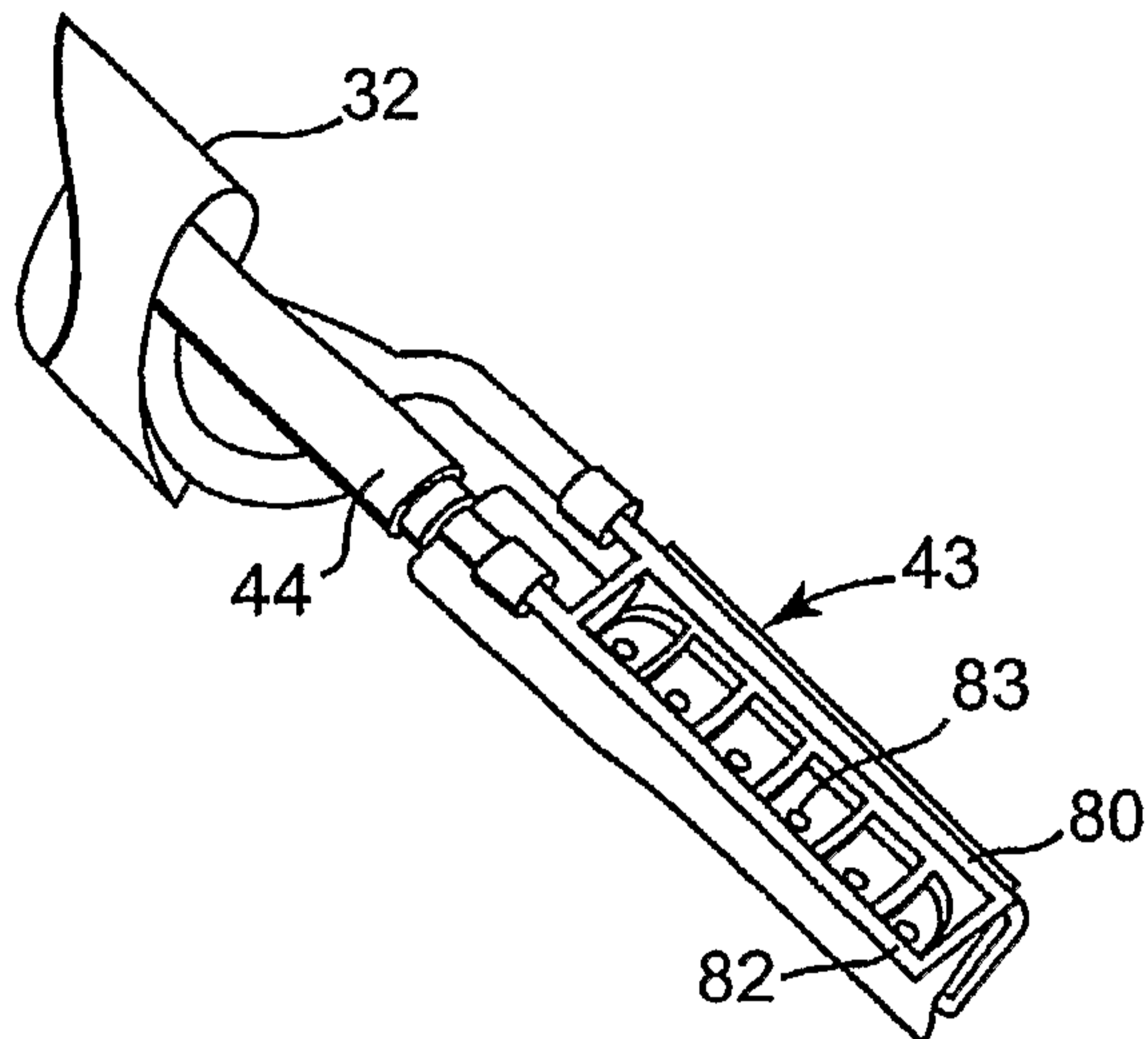


**Fig. 5A**

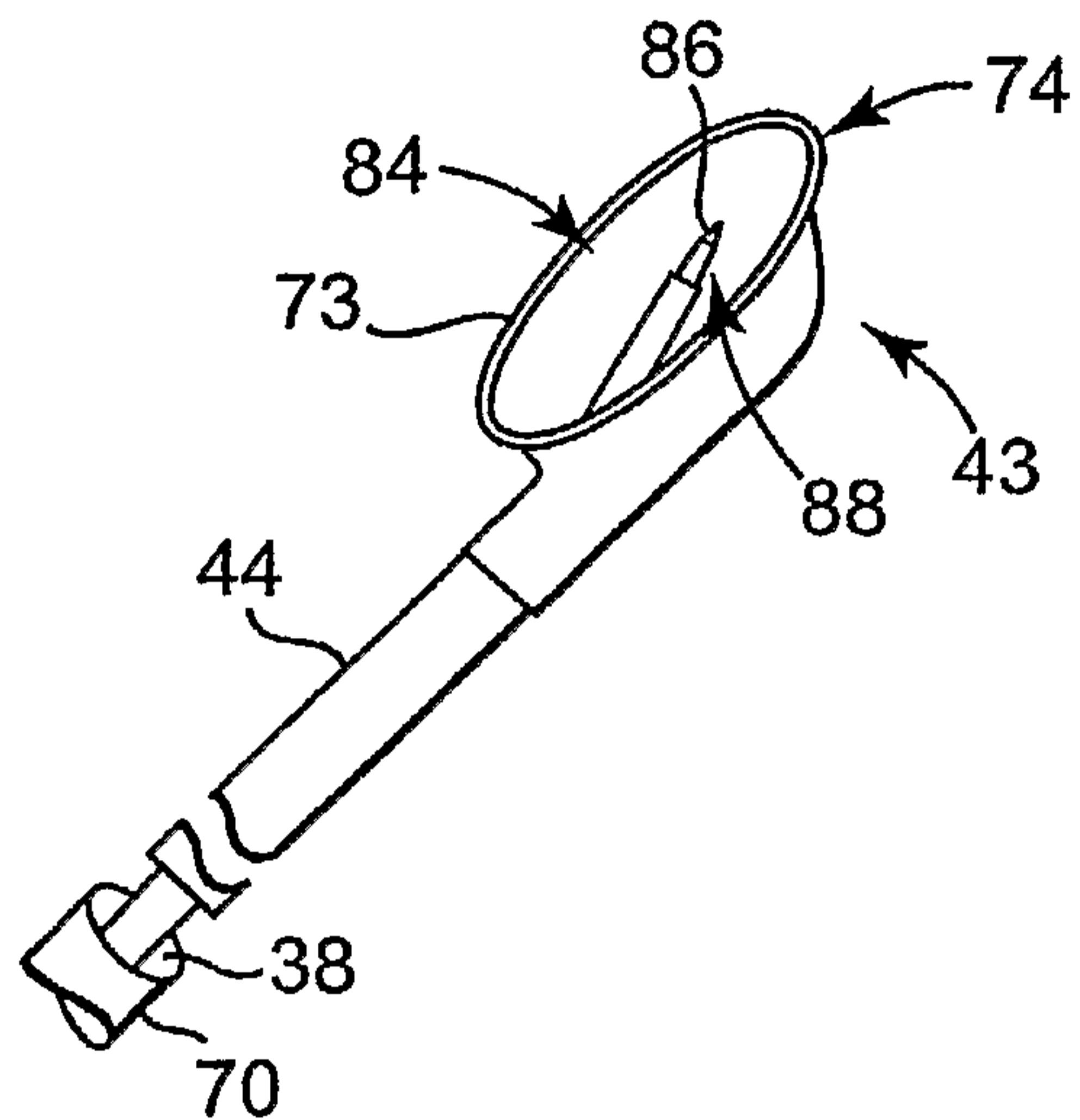


**Fig. 6**

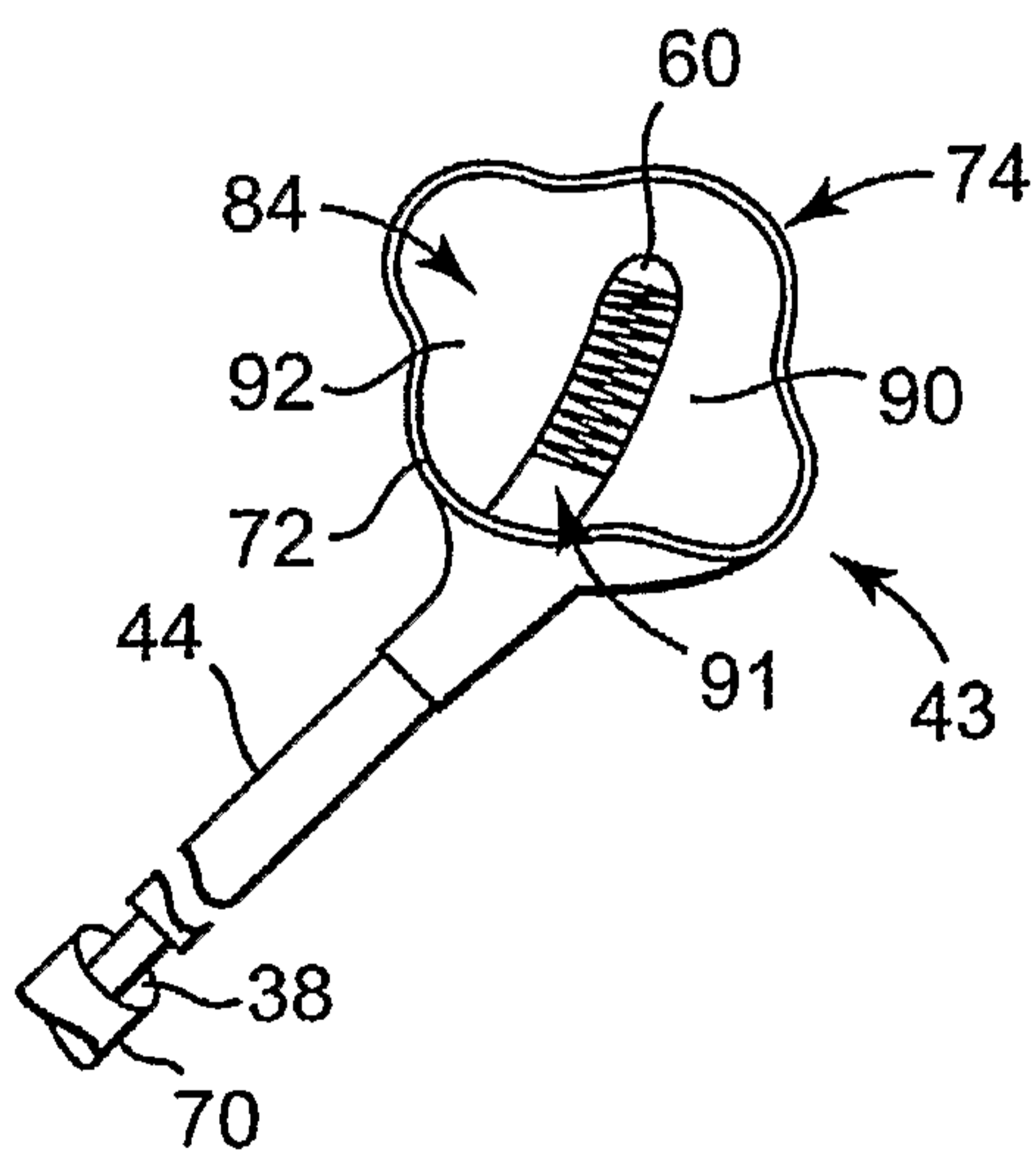




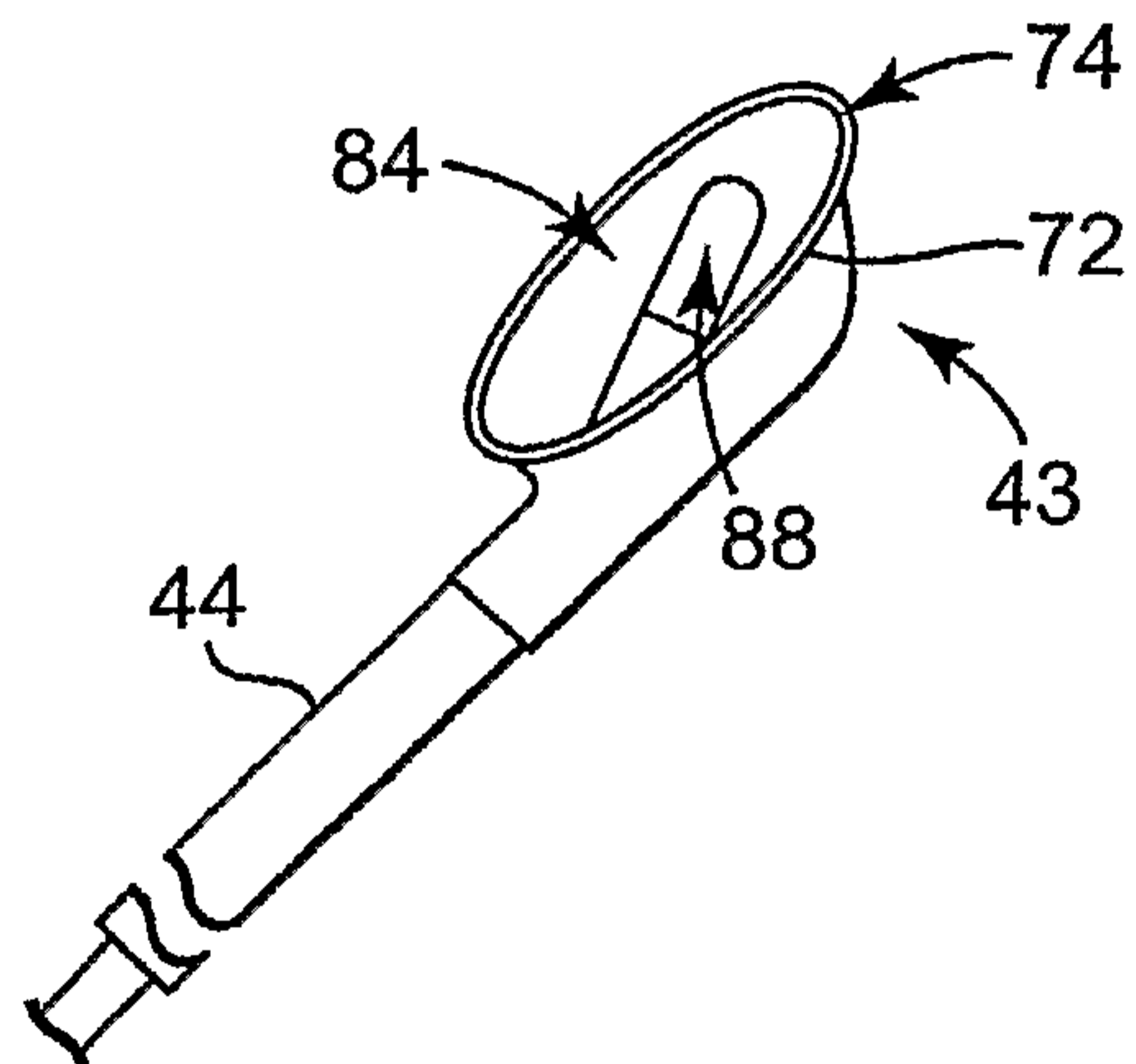
**Fig. 7**



**Fig. 8**



**Fig. 9**



**Fig. 10**

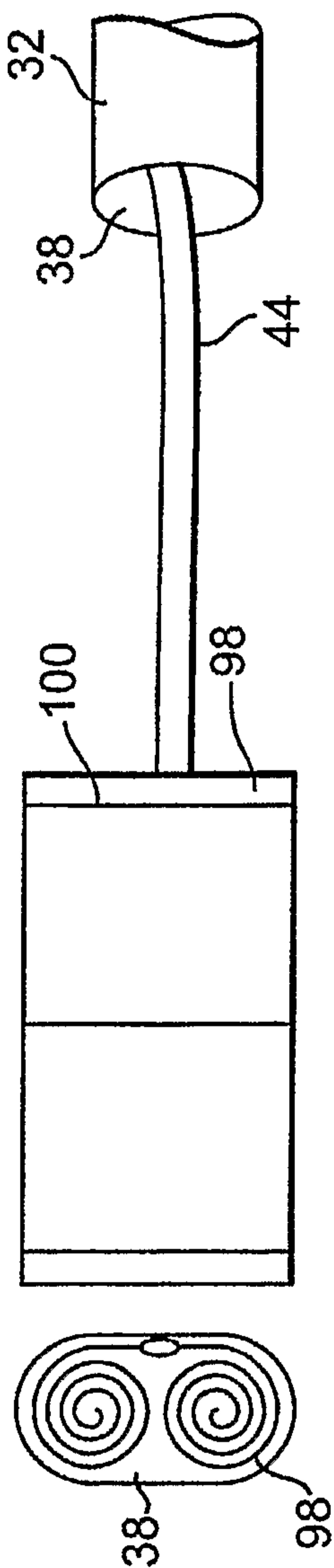


Fig. 11

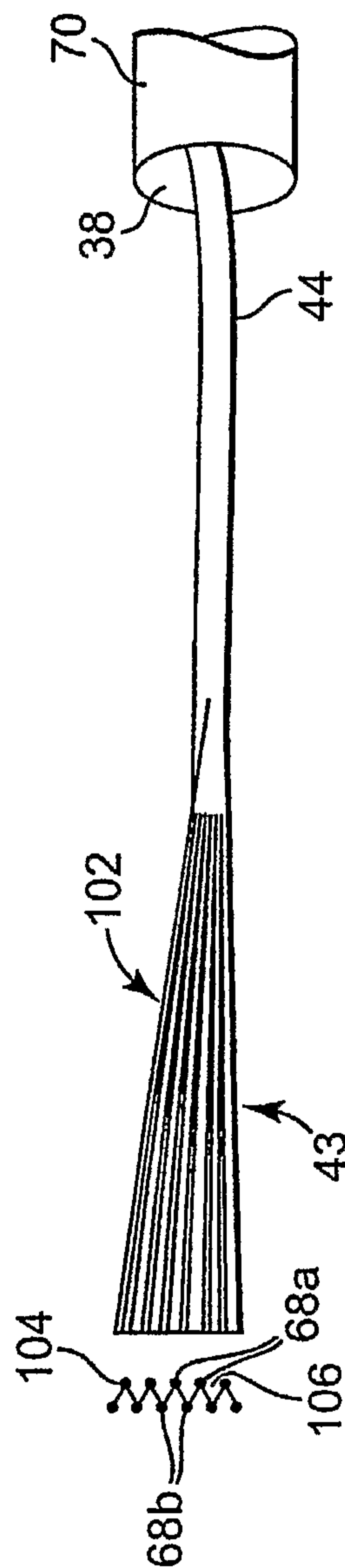


Fig. 12



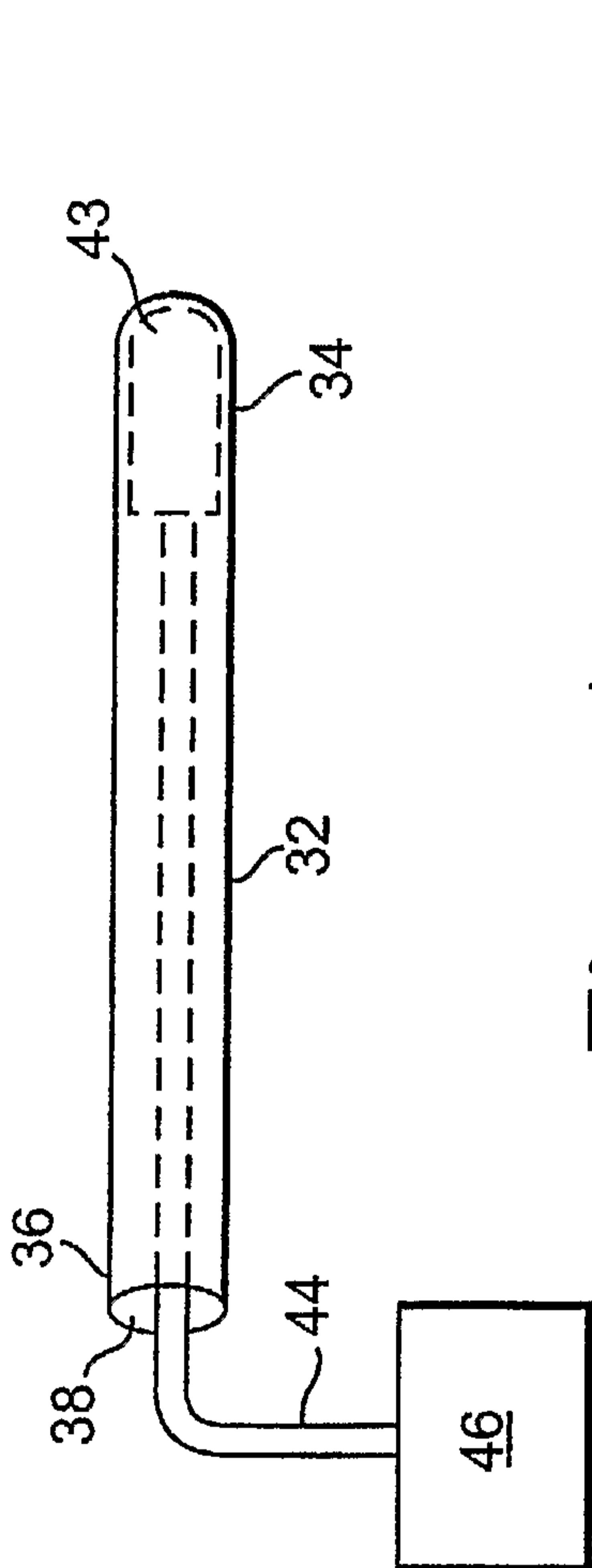


Fig. 13A

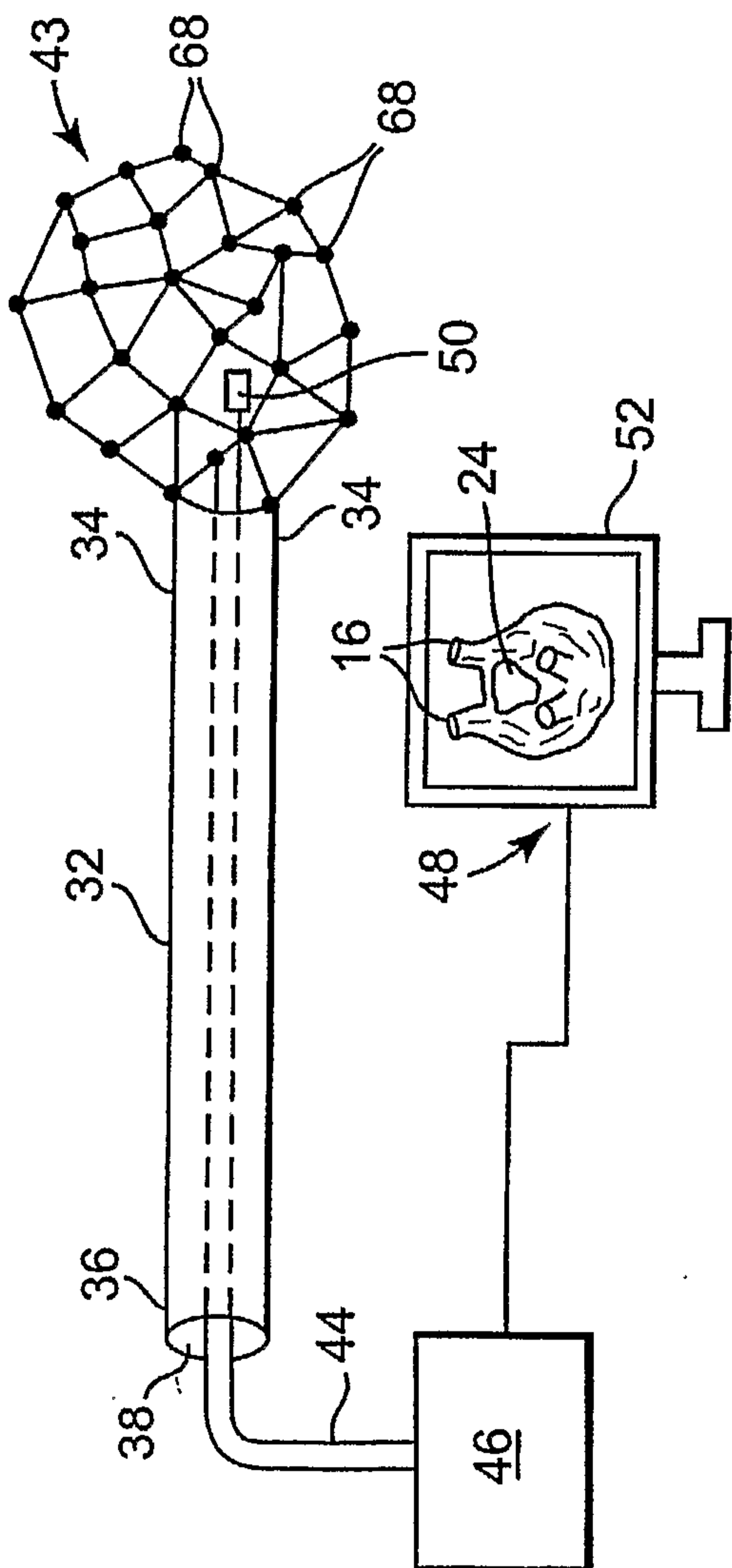
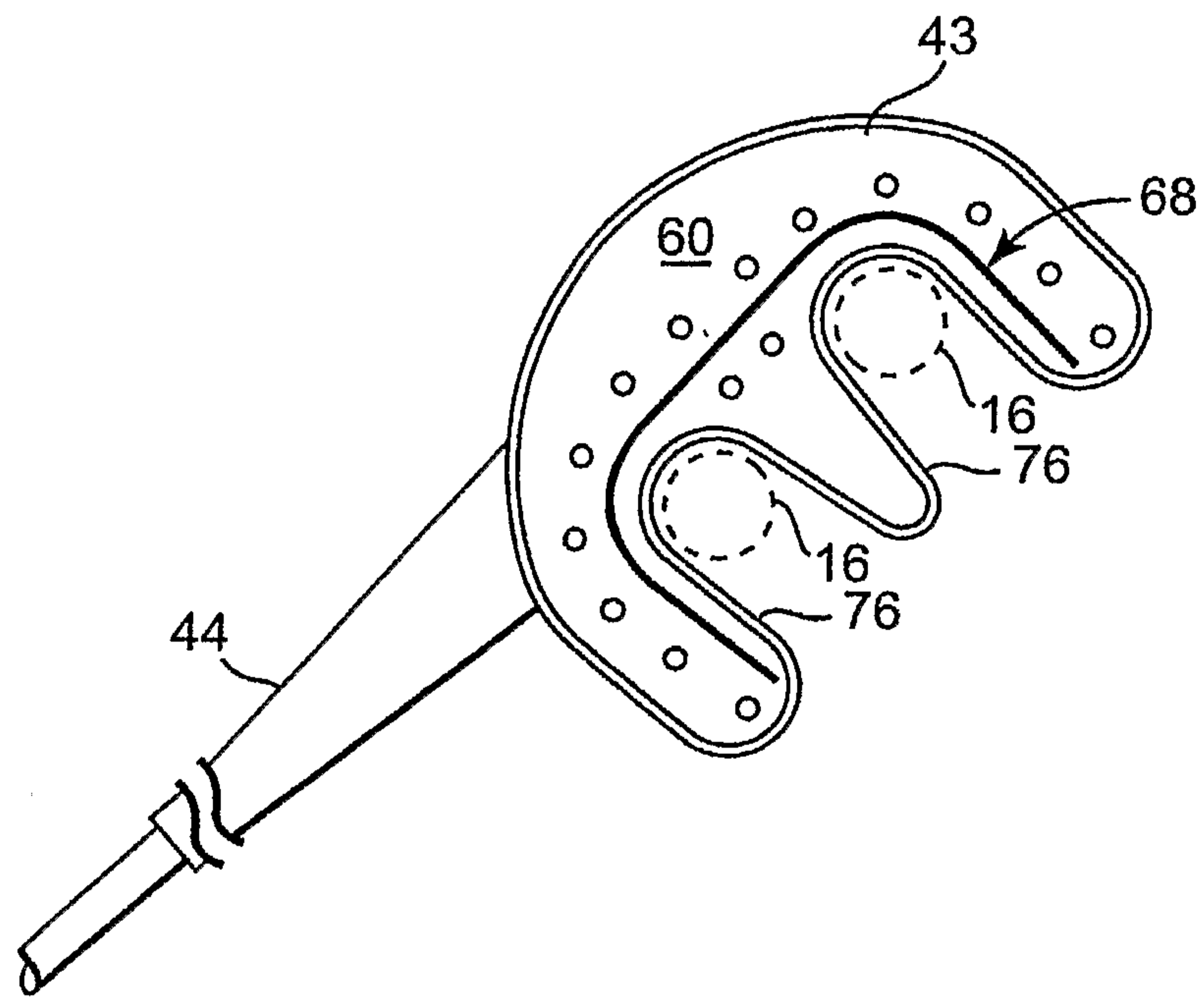
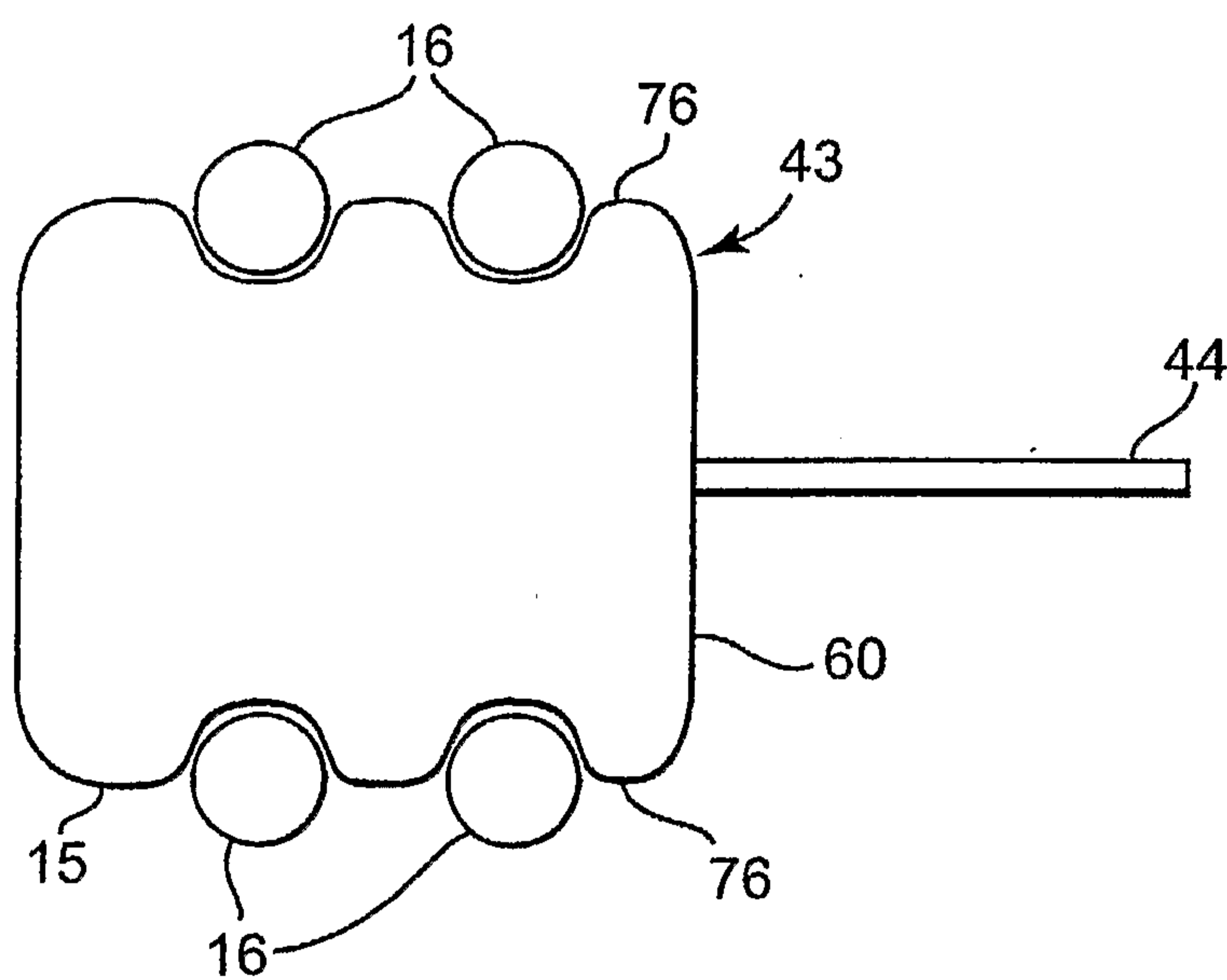


Fig. 13B

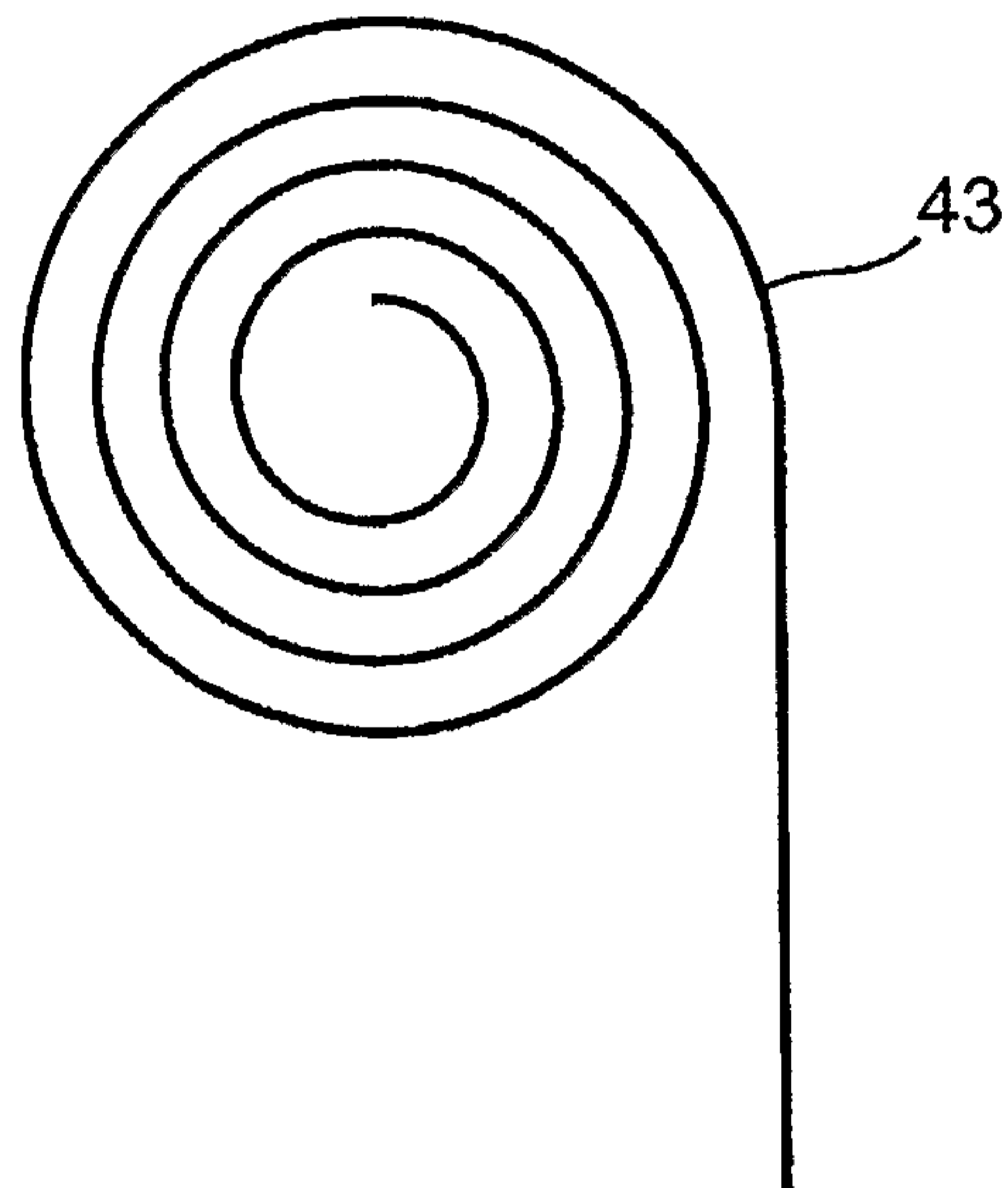


**Fig. 14**





**Fig. 15**



**Fig. 16**

