

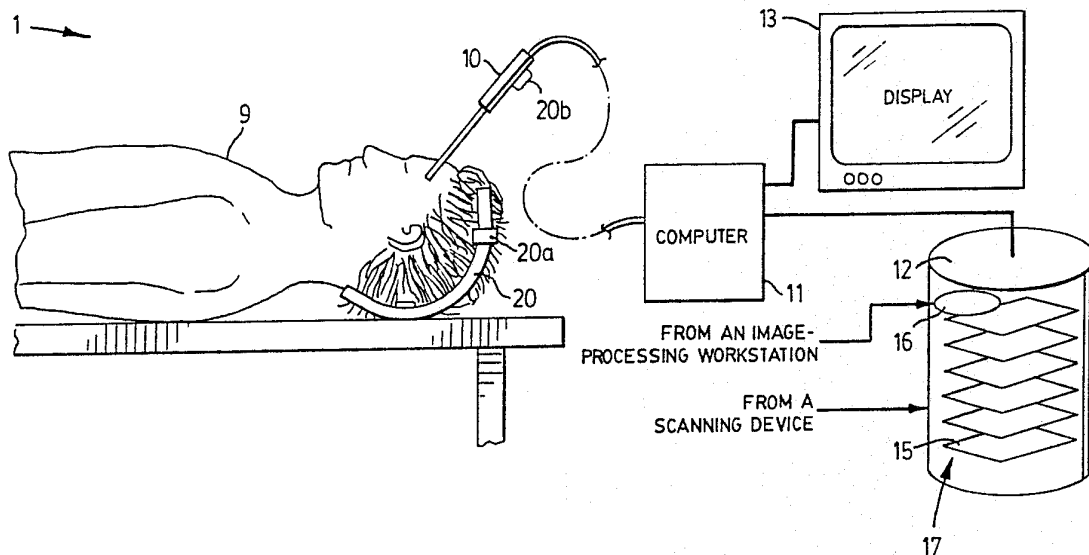

INTERNATIONAL APPLICATION PUBLISHED UNDER THE PATENT COOPERATION TREATY (PCT)

<p>(51) International Patent Classification <sup>5</sup> : <b>G06F 15/72, A61B 5/11</b></p>	<p><b>A1</b></p>	<p>(11) International Publication Number: <b>WO 91/07726</b> (43) International Publication Date: 30 May 1991 (30.05.91)</p>
<p>(21) International Application Number: PCT/CA90/00404 (22) International Filing Date: 21 November 1990 (21.11.90) (30) Priority data: 003,497 21 November 1989 (21.11.89) CA (71) Applicant: I.S.G. TECHNOLOGIES INC. [CA/CA]; 3030 Orlando Drive, Mississauga, Ontario L4V 1S8 (CA). (72) Inventors: GREENBERG, Michael, M. ; 34 Kew Gardens, Richmond Hill, Ontario L4B 1R5 (CA). DEKEL, Doron ; 50 Robert Hicks Drive, Willowdale, Ontario M5R 2R3 (CA). ZINREICH, Simion, J. ; 10 Stream Ct., Owings Mills, MD 21217 (US). BRYAN, Robert, N. ; 212B Stony Run Lane, Baltimore, MD 21200 (US).</p>		<p>(74) Agent: ROGERS, BERESKIN &amp; PARR; 40 King Street West, 40th Floor, Toronto, Ontario M5H 3Y2 (CA). (81) Designated States: AT, AT (European patent), AU, BB, BE (European patent), BF (OAPI patent), BG, BJ (OAPI patent), BR, CF (OAPI patent), CG (OAPI patent), CH, CH (European patent), CM (OAPI patent), DE, DE (European patent), DK, DK (European patent), ES, ES (European patent), FI, FR (European patent), GA (OAPI patent), GB, GB (European patent), GR, GR (European patent), HU, IT (European patent), JP, KP, KR, LK, LU, LU (European patent), MC, MG, ML (OAPI patent), MR (OAPI patent), MW, NL, NL (European patent), NO, RO, SD, SE, SE (European patent), SN (OAPI patent), SU, TD (OAPI patent), TG (OAPI patent).  <b>Published</b> <i>With international search report. Before the expiration of the time limit for amending the claims and to be republished in the event of the receipt of amendments.</i></p>

(54) Title: PROBE-CORRELATED VIEWING OF ANATOMICAL IMAGE DATA



(57) Abstract

A computerized system for viewing of internal anatomical regions of a patient based on previously acquired image data of the patient. The anatomical regions are viewed in direct relationship to a moving probe which can be hand-held. The location of the probe relative to the patient is reported to computer. The computer then uses the previously acquired image data to generate a desired view of the patient's anatomy in relationship to the position or orientation of the probe. An operator is able to visualize normally invisible anatomical features before commencing, and during, procedure. The correspondence between positions of the patient's anatomy to locations on the stored data images is determined through an initialization procedure which can be repeated or refined between viewing operations. The system may be employed during diagnostic, therapeutic, or surgical procedures.

**FOR THE PURPOSES OF INFORMATION ONLY**

Codes used to identify States party to the PCT on the front pages of pamphlets publishing international applications under the PCT.

<b>AT</b>	Austria	<b>FI</b>	Finland	<b>ML</b>	Mali
<b>AU</b>	Australia	<b>FR</b>	France	<b>MN</b>	Mongolia
<b>BB</b>	Barbados	<b>GA</b>	Gabon	<b>MR</b>	Mauritania
<b>BE</b>	Belgium	<b>GB</b>	United Kingdom	<b>MW</b>	Malawi
<b>BF</b>	Burkina Faso	<b>GN</b>	Guinea	<b>NL</b>	Netherlands
<b>BG</b>	Bulgaria	<b>GR</b>	Greece	<b>NO</b>	Norway
<b>BJ</b>	Benin	<b>HU</b>	Hungary	<b>PL</b>	Poland
<b>BR</b>	Brazil	<b>IT</b>	Italy	<b>RO</b>	Romania
<b>CA</b>	Canada	<b>JP</b>	Japan	<b>SD</b>	Sudan
<b>CF</b>	Central African Republic	<b>KP</b>	Democratic People's Republic of Korea	<b>SE</b>	Sweden
<b>CG</b>	Congo	<b>KR</b>	Republic of Korea	<b>SN</b>	Senegal
<b>CH</b>	Switzerland	<b>LI</b>	Liechtenstein	<b>SU</b>	Soviet Union
<b>CI</b>	Côte d'Ivoire	<b>LK</b>	Sri Lanka	<b>TD</b>	Chad
<b>CM</b>	Cameroon	<b>LU</b>	Luxembourg	<b>TG</b>	Togo
<b>DE</b>	Germany	<b>MC</b>	Monaco	<b>US</b>	United States of America
<b>DK</b>	Denmark	<b>MG</b>	Madagascar		
<b>ES</b>	Spain				

- 1 -

Title: Probe-correlated viewing of anatomical image data  
FIELD OF THE INVENTION

The invention relates generally to visualizing anatomical images. More specifically, the invention  
5 relates to a method and apparatus for determining the position of a probe relative to various anatomical features and displaying the internal anatomical structures corresponding to the position of the probe.

BACKGROUND OF THE INVENTION

10 In recent years it has become commonplace for a surgeon to utilize slice images of a patient's internal organs. The images are used to plan the course of a medical procedure, be it diagnostic, therapeutic, or surgical, and for orientation during the procedure. The  
15 slice images are typically generated by Computerized Tomography (CT) or by Magnetic Resonance Imaging (MRI). Images may also be captured using Angiography, Single-Photon Emission Computed Tomography, and Positron Emission Tomography methods.

20 The images typically presented to a user consist of a series of static images on film. These images are very detailed and can resolve anatomical structures less than one millimetre in size. However, their format differs greatly from the actual anatomical features seen  
25 during the surgical procedure. The images are presented in two-dimensional form rather than in the three-dimensional form of the anatomical features. In addition, the perspective of the slice image rarely corresponds to the surgeon's viewing angle during the procedure.  
30 Consequently, during a procedure, the slice images provide a primitive visualization aid to the patient's anatomy.

To obtain proper orientation within a patient's body, surgeons can make an incision which is larger than the minimum required for the planned procedure. While  
35 providing an enlarged window to the patient's anatomy, these larger incisions may result in longer hospital stays

**SUBSTITUTE SHEET**

- 2 -

and increased risk for the patient. On the other hand, if only a small incision is made, the field of view available to the surgeon is greatly limited. As a result, the surgeon may become disoriented forcing him to correct  
5 and recommence the procedure, or to continue at a high risk to the patient.

While imaging equipment can be used to provide on-the-spot visualization of a patient, it is impractical to use the equipment in the operating room during the  
10 procedure. First, the costs of purchasing, operating and maintaining the imaging equipment are prohibitive. Secondly, surgeons have limited access to a patient who is placed in a scanning device. Furthermore, Magnetic Resonance Imaging and Computerized Tomography have side  
15 effects which may harm the patient and inhibit the procedures. Magnetic Resonance Imaging produces a very high fixed magnetic field which precludes the use of many  
5 instruments. Computerized Tomography, on the other hand, utilizes X-ray radiation which is known to damage human tissue and cause cancer. It is, therefore, not desirable to expose a patient to a computerized tomography scan for a prolonged period.

10 A known approach to localizing anatomy during surgery is currently being used for brain lesions. The method is known as stereotactic surgery. It involves rigidly attaching the reference frame to the patient's head during the scanning. Using the marks left in the  
15 scanned images by the frame, the location of the lesion is computed. During the surgical procedure, a reference frame is again attached to the same location on the patient's head. The frame is used to direct drilling and cutting operations, which are done either manually or  
20 automatically.

Stereotactic surgery has a number of drawbacks. Firstly, it is only suitable for localized brain lesions which have a direct approach path. Secondly, stereotactic surgery requires the use of a cumbersome and uncomfortable

**SUBSTITUTE SHEET**

- 3 -

reference frame. Furthermore, since the decision to undertake stereotactic surgery is usually done after a first scanning procedure, the patient must undergo a second scan with the frame attached. This results in a  
5 prolonged and expensive procedure. Moreover, if the scan utilizes computerized tomography imaging, then the patient is exposed to another dose of radiation.

Known in the art are systems and methods designed to allow the use of previously acquired Computer  
10 Tomography or Magnetic Resonance Imaging scans as an aide in conventional open neurosurgery. In general, these methods use systems comprising:

- (a) a multi-jointed probe or sensor arm;
- (b) a computer processing unit which calculates  
15 the position of the probe arm relative to certain reference points on the patient; and
- (c) a means of displaying the superpositioning of the location of the probe arm as calculated above on the previously acquired scan images.

20 The display capabilities of such systems are limited in that they can display only the slice images as generated by the computerized tomography or magnetic resonance imaging scan. An example of such a system is disclosed in an international Application filed by Georg  
25 Schlöndovff and published under No. WO88/09151. This application is mainly concerned with an arm structure for locating the position of a probe.

#### SUMMARY OF THE INVENTION

In a first aspect the invention provides a  
30 method for visualizing internal regions of an anatomical body in relation to a probe, employing a data-base body of previously acquired images of the anatomical body, the method comprising the steps of:

- (a) obtaining a spatial position for the probe  
35 relative to the anatomical body;
- (b) determining a data-base location relative to

**SUBSTITUTE SHEET**

the data-base body corresponding to the spatial position of the probe relative to the anatomical body;

(c) mapping the spatial position of the probe relative to the anatomical body to the corresponding data-base location of the probe relative to the data-base body; and

(d) displaying a region of the data-base body adjacent the data-base location of the probe.

In a second aspect the invention provides a system for visualizing internal regions of an anatomical body by utilizing a data-base body of previously acquired images of the anatomical body, the system comprising:

(a) a probe;

(b) a data-base storage unit containing the previously acquired images of the anatomical body;

(c) a spatial determinator for determining the spatial position of the probe relative to the anatomical body;

(d) a computer using the previously acquired images to generate a representation of a region of the anatomical body adjacent to the spatial position of the probe; and

(e) a display unit for displaying the representation of the anatomical body.

#### 25 BRIEF DESCRIPTION OF THE DRAWINGS

For a better understanding of the present invention, and to show more clearly how it may be carried into effect, reference will now be made by way of example to the accompanying drawings which show alternate 30 embodiments of the present invention, and in which:

Figure 1 is a first embodiment of a probe-correlated imaging system;

Figure 2 is a portion of a second embodiment of a probe-correlated imaging system;

35 Figure 3 is a portion of a third embodiment of a probe-correlated imaging system;

**SUBSTITUTE SHEET**

- 5 -

Figure 4 is a first display format employed in the system of fig. 1;

Figure 5 is a second display format employed in the system of fig. 1; and

5 Figure 6 is a third display format employed in the system of fig. 1.

#### DETAILED DESCRIPTION OF THE PREFERRED EMBODIMENT

Referring to fig. 1 a probe-correlated system (1) has a probe (10), a computer (11), a data storage unit 10 (12), and a display (13). These components are, individually, well known and common. The system (1) is employed to view the anatomical structure of a patient (9) adjacent to the position of the probe (10).

The computer (11) has ready access to the unit 15 (12) which contains a data-base body (17) representing the anatomical structure of the patient (9). The data-base body (17) includes previously acquired digital images (15) of the patient (9). These images (15) can be acquired through various medical-imaging techniques, such as 20 Computerized Tomography, Single-Photon Emission Computed Tomography, Positron Emission Tomography, Magnetic Resonance Imaging, Ultrasound, or Angiography.

In addition to the digital images (15) captured by medical-imaging techniques, the data-base body (17) can 25 contain pre-processed digital images (16). For example, the digital images (15) together with their relative spatial relationship can be pre-processed to represent the various organ surfaces of the patient (9). There are known systems, not shown, which can read digital images 30 (15) and generate pre-processed digital images (16) according to their relative spatial relationship within the anatomical structure of the patient (9). The known system places the pre-processed images (16) in the data-base body (17). The probe (10), or any other object which 35 may function as a probe, is used by an operator, not shown, to point to a particular location on the anatomical

**SUBSTITUTE SHEET**

- 6 -

body of the patient (9). The operator can move the probe (10) around or within the anatomical body of the patient (9).

Spatial coordinates, representing the spatial position and possibly the spatial orientation, of the probe relative to a fixed reference point, shown generally at the arrow (20), are conveyed to the computer (11). The reference point (20) may either be on the patient (9) as shown, or on some stable platform nearby, not shown. There are a number of alternate methods which can be used to obtain the spatial coordinates of the probe (10) relative to its reference point (20). The apparatuses described in association with such method will be collectively referred to as spatial determinators.

Referring to fig. 1, an electro-magnetic emitter (20a) is positioned at the reference point (20) and a sensor (20b) is located on the probe (10). By comparing the timing and phase of transmitted signals from the emitter (20a) to received signals picked up by the sensor (20b), the position and orientation of the probe (10) relative to the reference point (20) can be determined. A probe (10) using this known locating method is commercially available. Given the spatial relationship between the reference point (20) and the patient (9), the computer (11) can determine the position of the probe (10) relative to the patient (9).

Alternately, referring to fig. 2, the probe (10) is attached to a multi-joint light-weight arm (25) with a first section (26) and a second section (27) connected together at joint (22). The first section (26) of the multi-joint arm (25) is connected to a base (28) at joint (21). The base (28) is attached to the patient (9) using adhesive elastic tape (23). The probe (10) is attached to the second section (27) at joint (24).

The joints (21), (22), (24), in combination, provide for a range of motion equal to or greater than that required for a given procedure. Angular sensors, not

**SUBSTITUTE SHEET**



- 7 -

shown, are located at the joints (21), (22), (24).

The angular sensors are connected by wire (28a) to one another and to an electronic unit (29). The sensors detect any change in the position or orientation of the multi-joint arm (25), and convey this information to the electronic unit (29).

The unit (29) uses geometric calculations to determine the spatial position and spatial orientation of the probe (10) relative to the base (28) which is used as the reference point. The spatial position and spatial orientation of the probe (10) are sent to the computer (11) of fig. 1 through an electronic communication link (27). A suitable communication link (27) would be an RS-232 serial communication interface. Since the base (28) is fixed to the body of the patient (9), the computer can use the spatial information to determine the position of the probe (10) relative to the patient (9).

Alternately, referring to fig. 3, a dual-arm arrangement, shown generally at (31), may be employed. The arrangement (31) is particularly effective where the multi-joint arm (30) of fig. 2 cannot be fixed to the patient (9).

A stand (35) is used to anchor two multi-joint arms (36, 37) similar to the multi-joint arm (30) of fig. 2. A probe (10) is attached to the other end of arm (37). Arm (36) is attached at its other end to a reference point (40) on the patient (9). Sensors are mounted at joints (41, 42, 43) of arm (37), and at joints (44, 45, 46) of arm (36). The sensors, in turn, are connected to an electronic unit (39). The electronic unit (39) decodes the position and orientation of the probe (10). Through the relative spatial positions and orientations of the probe (10) to the joint (41), the joint (41) to the joint (44) and the joint (44) to the reference point (40), the spatial position and orientation of the probe (10) relative to the patient (9) is obtained. The spatial position and orientation of the probe (10) is transmitted

**SUBSTITUTE SHEET**

to the computer (11) of fig. 1 via the communication link (47).

The reference arm (36) shown in fig. 3 can be omitted if the patient (9) is fixed to an operating table (48). The patient can be fixed to the table (48) using straps (49). If the patient (9) is fixed, then the reference point (40) can be fixed arbitrarily in space. The relative position of the reference point (40) to the joint (41) may be determined once and the relative position of the probe (10) to the reference point (40) determined therefrom. However, if the patient (9) is moved during the procedure, a new reference point (40) or a new spatial relationship must be established.

To display the data-base image (15) or pre-processed image (16) which correctly corresponds to the region of the anatomical body of the patient (9) adjacent the probe (10), the system (1) must be able to map positions of the anatomical body of the patient (9) to locations in data-base body (17) during the procedure. In this sense mapping is a procedure for determining the current spatial position of the probe (10) and the corresponding adjacent data-base body (17) location. This correspondence may be initially determined through a procedure which maps the patient (9) to the data-base body (17). This procedure is known as "registration" since its purpose is to register the correspondence between the anatomical body of the patient (9) and the data-base body (17) with the computer (11).

A number of registration methods are known. For example, one method involves the marking of reference points on the patient (9). However, this can be inconvenient and there is a risk that the marked positions on the patient (9) may be erased between the time the scan images (15) were generated and the time the surgical procedure is performed. Another method involves placing small markers, usually made of cad or ceramic material, on readily identifiable features of the patient, such as the

**SUBSTITUTE SHEET**

ears or the corners of the eyes.

The preferred registration method involves using the probe (10) to register with the computer (11) the spatial position of easily identifiable features of the patient, such as the space between the teeth, the nose or the corners of the eyes. In this method, the previously acquired scan images (15) or the pre-processed images (16) are displayed on the display (13) in such a manner as to allow the user of the system (1) to identify specific points of the chosen features of the patient (9). A three dimensional surface format, shown in figure 6, is the simplest such format for an unskilled viewer to comprehend. Such a three-dimensional surface format can be derived from the pre-processed images (16) in a known manner, and suitable points such as the corners of the eyes (70), space between the teeth (72) are shown in figure 6.

The method is as follows. The probe (10) is placed next to the feature point on the patient (9). The spatial position of the probe (10) is then determined. A movable marker, e.g. a cursor, on the display (13) is then adjusted so it coincides with a selected feature, e.g. corner of the eyes (70) as seen. It is then relatively simple for the computer (11) to perform necessary three dimensional transformation, so that the spatial position of the probe (10) and the corresponding data-base body location are registered with the computer (11). Using a set of at least three, and preferably about six, feature points on the patient, a proper and unique transformation function, can be calculated which maps the spatial position of the probe (10) to the corresponding data-base body location and orientation. The accuracy of this transformation function is improved by the use of a larger number of points and a statistical error minimizing techniques, such as the least mean square error method.

Once the anatomical body of the patient (9) has been registered with the computer (11), the operator can

**SUBSTITUTE SHEET**

- 10 -

move the probe (10) in and around the patient (9), and at the same time view the hidden anatomical features of the patient (9) as they appear in the data-base body (17). The anatomical features of the patient (9) in the data-  
5 base body (17) are presented on the display unit (13) in relationship to the spatial position and possibly orientation of the probe (10).

It is not strictly necessary to use the orientation of the probe (10) to carry out many of the  
10 features of the invention. The probe (10) may be represented on the display (13) as a point rather than a full probe (10). The region adjacent the point probe (10) is then displayed. The orientation of the regions displayed is known from the computer (11) and not  
15 determined by the orientation of the probe (10).

A possible presentation format for the data-base images (15) of the patient (9) is shown in fig. 4. Two-dimensional representations or slice images are generated by the computer (11) from the data-base images (15). The  
20 position of the probe (10) relative to the anatomical body (9) is marked on a slice image (50) by the computer (11). The slice image (50) together with the probe (52) are displayed on the unit (13).

The screen of the display unit (13) is divided  
25 into 4 separate windows. Three of the windows contain slice images corresponding to three cardinal anatomical planes: sagittal (50); axial (54); and coronal (56). The three slice images (50, 54, 56) intersect at the location of the probe (52). Thus, the operator can observe the  
30 anatomical feature of the patient (9) relative to the position of the probe (10) in the six main directions: anterior, posterior, superior, inferior, right and left. The fourth window depicted on the display unit (13) can show a slice (57) through the anatomical features in mid-  
35 sagittal orientation along the axis of the probe (10). The position and orientation of the probe (10) can be marked on the slice (57), thereby allowing the operator to

**SUBSTITUTE SHEET**

- 11 -

direct viewing of what lies ahead of the probe (10).

Another presentation format for the data-base images (15) and pre-processed images (16) is shown in fig. 5. A three-dimensional model (58) of the patient (9) is  
5 generated by the computer (11) from the images (15, 16).

The computer (11) also generates a three-dimensional model (60) of the probe (10). The relative locations of the models (60), (58) correspond to the spatial position and orientation of the probe (10) relative to the patient  
10 (9). The three-dimensional model (58) of the patient (9) generated from the stored images (15, 16) is presented together with the model (60) on the display unit (13).

Other display methods than the display of slices or using pre-processing may be used in conjunction with  
15 the principles described herein. For example, the computer (11) can generate displays directly from the images (15) using a ray-cast method. In one ray-cast method the computer (11) creates the display using the results of simulated X-rays passing through the images  
20 (15). The simulated X-rays will be affected differently by different elements in the images (15) according to their relative absorption of the X-rays. The results may be displayed along with the probe (10) in a manner similar to those described for slices or 3d-images. This produces  
25 a simulated X-ray display. In another ray-cast method a display is created using the results of simulated light rays passing through the images (15). The elements in the images (15) which do not pass the simulated light rays correspond to surface features and may be used to generate  
30 a display similar to the three-dimensional model (58).

There are other ray casting methods which are well known in the art.

The computer (11) can be used to further process the slice image (50) and three-dimensional images (58)  
35 generated from the data-base body (17). For example, a wedge-shaped portion (62) has been cut from the three-dimensional image (58). The cut-out portion (62) exposes

**SUBSTITUTE SHEET**

various structures adjacent to the probe (10), which would not otherwise be observable. In addition, the cut-out portion (62) gives the operator an unobstructed view of the position of the probe (10) even if it is within the patient (9). The slice images (50) and three-dimensional images (58), (60) can also be processed by the computer (11) using other known image processing techniques. For example, the model (60) of the probe (10) can be made translucent, or the slice image (50) can be combined with other slice views.

While the present invention has been described with reference to certain preferred embodiments various modifications will be apparent to those skilled in the art and any such modifications are intended to be within the scope of the invention as set forth in the appended claims.

**SUBSTITUTE SHEET.**

WE CLAIM:

1. A method for visualizing internal regions of an anatomical body in relation to a probe, employing a data-base body of previously acquired images of the anatomical body, the method comprising the steps of:
  - (a) obtaining a spatial position for the probe relative to the anatomical body;
  - (b) determining a data-base location relative to the data-base body corresponding to the spatial position of the probe relative to the anatomical body;
  - (c) mapping the spatial position of the probe relative to the anatomical body to the corresponding data-base location of the probe relative to the data-base body; and
  - (d) displaying a region of the data-base body adjacent the data-base location of the probe, the region being derived from a plurality of adjacent images of the data-base body.
  
2. A method as recited in claim 1, wherein displaying a region of the data-base body adjacent to the data-base location of the probe comprises the steps of:
  - (a) generating a slice image from the previously acquired images and intersecting a plurality of adjacent images, representing a region of the database body adjacent to a data-base location of the probe; and
  - (b) displaying the slice image.
  
3. A method as recited in claim 1, wherein displaying a region of the data-base body adjacent to the data-base location of the probe comprises the steps of:
  - (a) generating a three-dimensional body model from the previously acquired images representing a region

of the data-base body adjacent to the data-base location of the probe; and

(b) displaying the three-dimensional body model.

4. A method as recited in claim 1, wherein displaying a region of the data-base body adjacent to the data-base location of the probe comprises the steps of :

(a) generating a three-dimensional body model from previously acquired images which have been preprocessed to depict anatomical features and which represent a region of the data-base body adjacent to the data-base location of the probe; and

(b) displaying the three-dimensional body model.

5. A method as claimed in claim 4, wherein in step (a) a portion of the three-dimensional body model is removed to reveal a location corresponding to the location of the probe

6. A method as recited in claim 1, wherein displaying a region of the data-base body adjacent to the data-base location of the probe comprises the steps of:

(a) generating a display format through the use of a ray-cast method on previously acquired images representing a region of the data-base body adjacent to the data-base location of the probe; and

(b) displaying the display format.

7. A method as recited in claim 6 wherein the ray-cast method is selected from the group consisting of X-ray and light ray.

8. A method as recited in claim 6 or 7, wherein the display format is a three-dimensional format.

**SUBSTITUTE SHEET**



- 15 -

9. A method as recited in claim 1, 2 or 3 wherein the spatial orientation of the probe is obtained along with its spatial position.
  
10. A method as recited in claim 1, 2 or 3 wherein a representation of the probe is displayed along with the region of the data base body adjacent the data-base location of the probe and the relative locations of the representation of the probe and the data base body correspond to the spatial position of the probe relative to the anatomical body.
  
11. A method as claimed in claim 5, wherein a representation of the probe is displayed with the three-dimensional body model, the relative location of the representation of the probe to the three-dimensional body model corresponding to the spatial position of the probe relative to the anatomical body.
  
12. A method as claimed in claim 11, wherein the representation of the probe corresponds closely to the actual probe, and wherein the representation of the probe is additionally oriented to correspond to the orientation of the probe with respect to the anatomical body, and with the perspective of the representation of the probe and of the three-dimensional body model corresponding to one another.
  
13. A method as recited in claim 1, further comprising a step for registration prior to obtaining the spatial position, registration including the steps of:
  - (a) positioning the probe next to a particular feature of the anatomical body;

**SUBSTITUTE SHEET**

- 16 -

- (b) determining a spatial position for the probe;
- (c) displaying a region of the data-base body having a data-base body feature corresponding to the particular feature;
- (d) identifying the particular feature on the displayed region; and
- (e) registering the spatial position of the probe and the location on the data-base body corresponding to the position of the particular feature, whereby, a database location is determined to correspond with a spatial position of the probe.

14. A method as recited in claim 1, further comprising a step for registration prior to obtaining the spatial position, registration including the steps of:

- (a) marking locations in the data-base body which correspond to particular features of the anatomical body;
- (b) positioning the probe next to a particular feature of the anatomical body;
- (c) determining the spatial position of the probe;
- (d) registering the spatial position of the probe and its corresponding database body location, whereby, a database body location is determined to correspond with a spatial position of the probe.

15. A method as recited in claim 1, further comprising a step for registration prior to obtaining the spatial position, registration including the steps of:

- (a) marking a position on the anatomical body of a particular scanned image containing a corresponding location in the database body;
- (b) positioning the probe next to the marked position on the anatomical body;

**SUBSTITUTE SHEET**

- 17 -

(c) determining the spatial position of the probe;

(d) registering the spatial position of the probe and its corresponding data-base body location, whereby, a data-base body location is determined to correspond with a spatial position of the probe.

16. A method as claimed in claim 13, wherein the display of step (c) is a three-dimensional display.

17. A method as claimed in claims 13 or 16, wherein more than three data-base locations are identified and wherein errors between the corresponding data-base locations and spatial positions are minimized to improve the accuracy of the registration step.

18. A method as claimed in claim 17, wherein the errors are minimized using a least mean squares analysis.

19. A method as claimed in claim 13, wherein the probe is connected to the anatomical body in such a manner that, following registration, if the anatomical body is displaced, registration between the data-base body and the anatomical body is maintained.

20. A method as claimed in claim 19, wherein the probe is connected to the anatomical body by one of (a) a multi-joint arm and a base for securing to the anatomical body with the arm connecting the base to the probe and (b) a stand, a pair of multi-joint arms, one of which connects the probe to the stand and the other of which

**SUBSTITUTE SHEET**

extends to a reference point on the anatomical body

21. A system for visualizing internal regions of an anatomical body by utilizing a data-base body of previously acquired images of the anatomical body, the system comprising:
- (a) a probe;
  - (b) a data-base storage unit containing the previously acquired images of the anatomical body;
  - (c) a spatial determinator for determining the spatial position of the probe relative to the anatomical body;
  - (d) a computer using the previously acquired images to generate a representation of a region of the anatomical body adjacent to the spatial position of the probe; and
  - (e) a display unit for displaying the representation of the anatomical body.
22. A system as recited in claim 21, wherein the generated representations are displayed in a three-dimensional surface format.
23. A system as recited in claim 21, wherein the computer is adapted to be initialized for the location in the data-base storage unit corresponding to the spatial position of the probe by having the probe positioned next to a particular feature point of the anatomical body, determining a spatial position of the probe, displaying a region of the data-base body having a data-base body feature corresponding to the particular feature, having identified the particular feature on the displayed region, and registering the spatial position of the probe and the location on the data-base body

- 19 -

corresponding to the position of the particular feature.

24. A system as recited in claim 23, wherein the generated images are displayed in 3-dimensional format during registration, and the particular features are identified on the three-dimensional format.
25. A system as recited in claim 21, wherein the spatial determinator includes:  
(a) an electro-magnetic emitter on a reference point for transmitting a signal;  
(b) a sensor on the probe for receiving the signal; and  
(c) means for comparing the transmitted signal with the received signal to determine the position of the probe.
26. A system as recited in claim 21, wherein the spatial determinator includes:  
(a) a first section connected between first and second joints, the first joint being fixed to a reference point whose spatial relation to the anatomical body is known;  
(b) a second section connected between the first joint and a third joint, the third joint being connected to the probe;  
(c) first, second and third sensors positioned at the first, second and third joints; and  
(d) means connected to the first, second and third sensors for determining the position of the probe relative to the anatomical body.
27. A system as recited in claim 26, wherein the first, second and third sensors are angular sensors.

**SUBSTITUTE SHEET**

28. A system as recited in claim 27, wherein the reference point is on the anatomical body.
29. A system as recited in claim 21, wherein the spatial determinator includes:
- a) first, second, third and fourth sections;
  - b) a stand;
  - c) a first joint between the first section and the probe;
  - d) a second joint between the first and second sections;
  - e) a third joint between the second section and the stand;
  - f) a fourth joint between the stand and the third section;
  - g) a fifth joint between the third section and the fourth section;
  - h) a sixth joint between the fourth section and a reference point whose spatial position relative to the anatomical body is known;
  - i) sensors positioned at each of the joints; and
  - j) means connected to the sensors for determining the position of the probe relative to the anatomical body.
30. A system as recited in claim 21, 26 or 29, wherein the spatial determinator determines the spatial orientation of the probe as well as its spatial position.

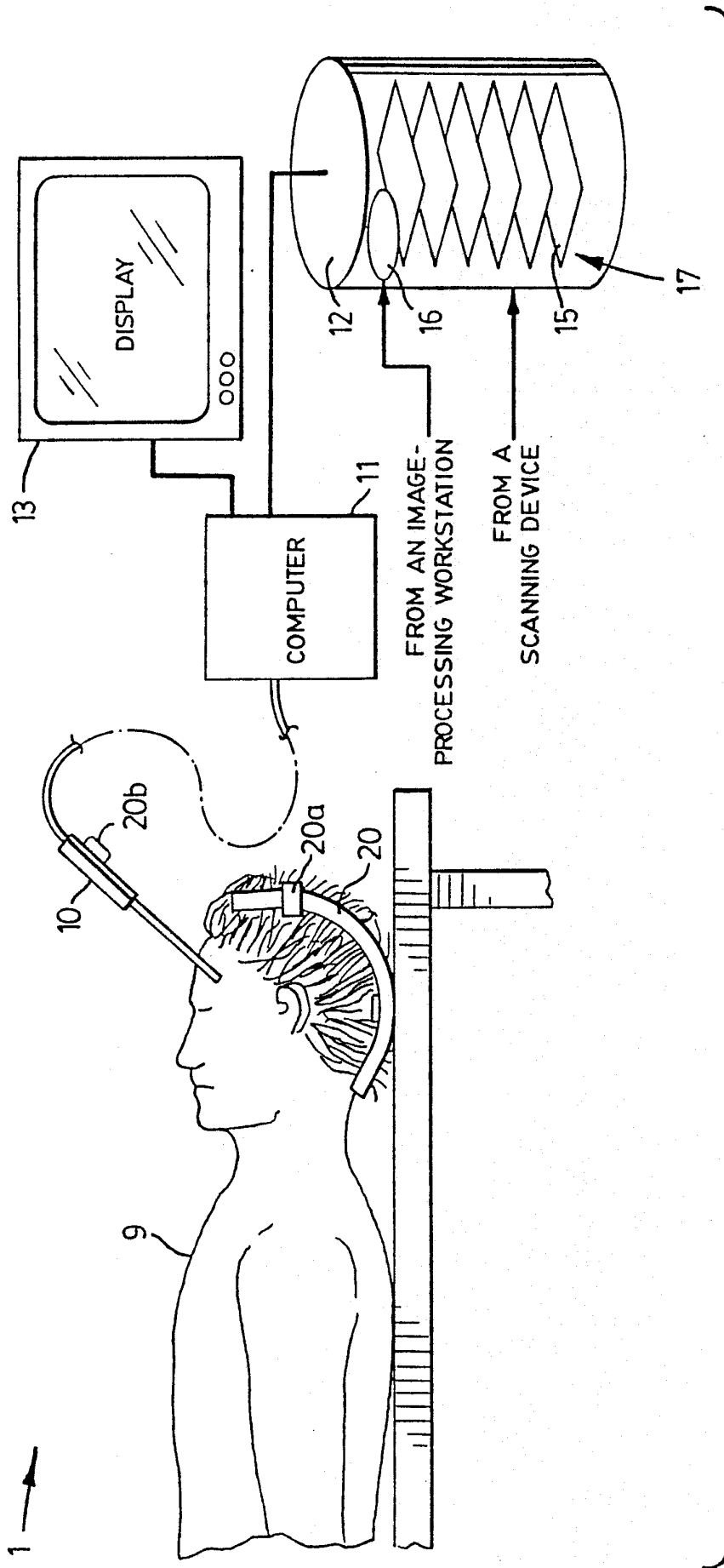

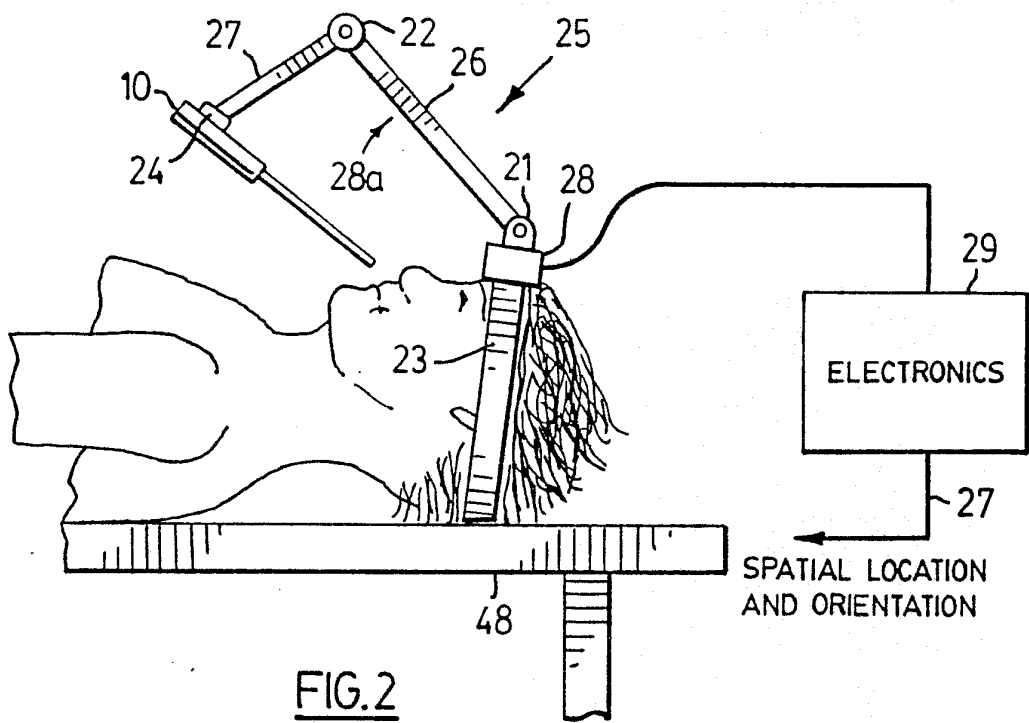

FIG. 2

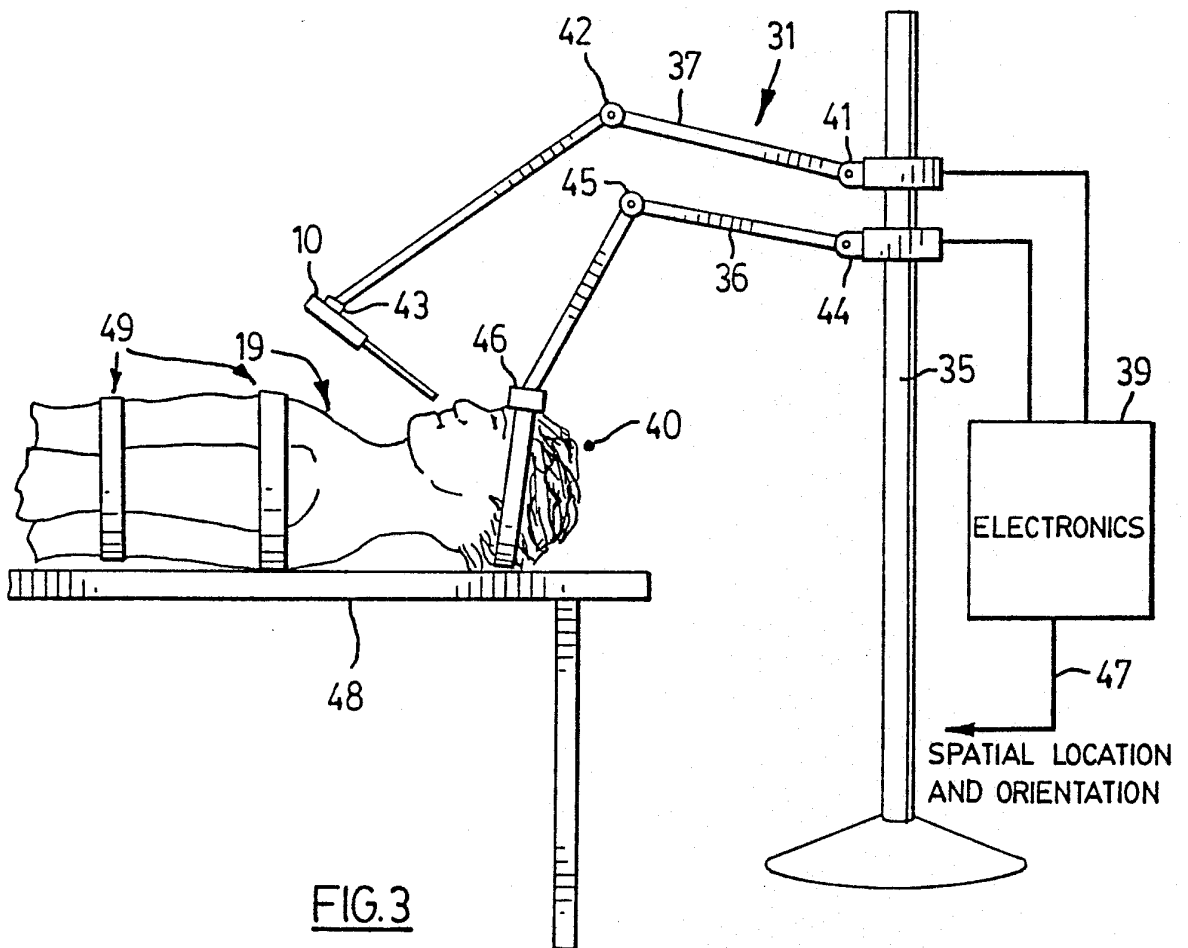
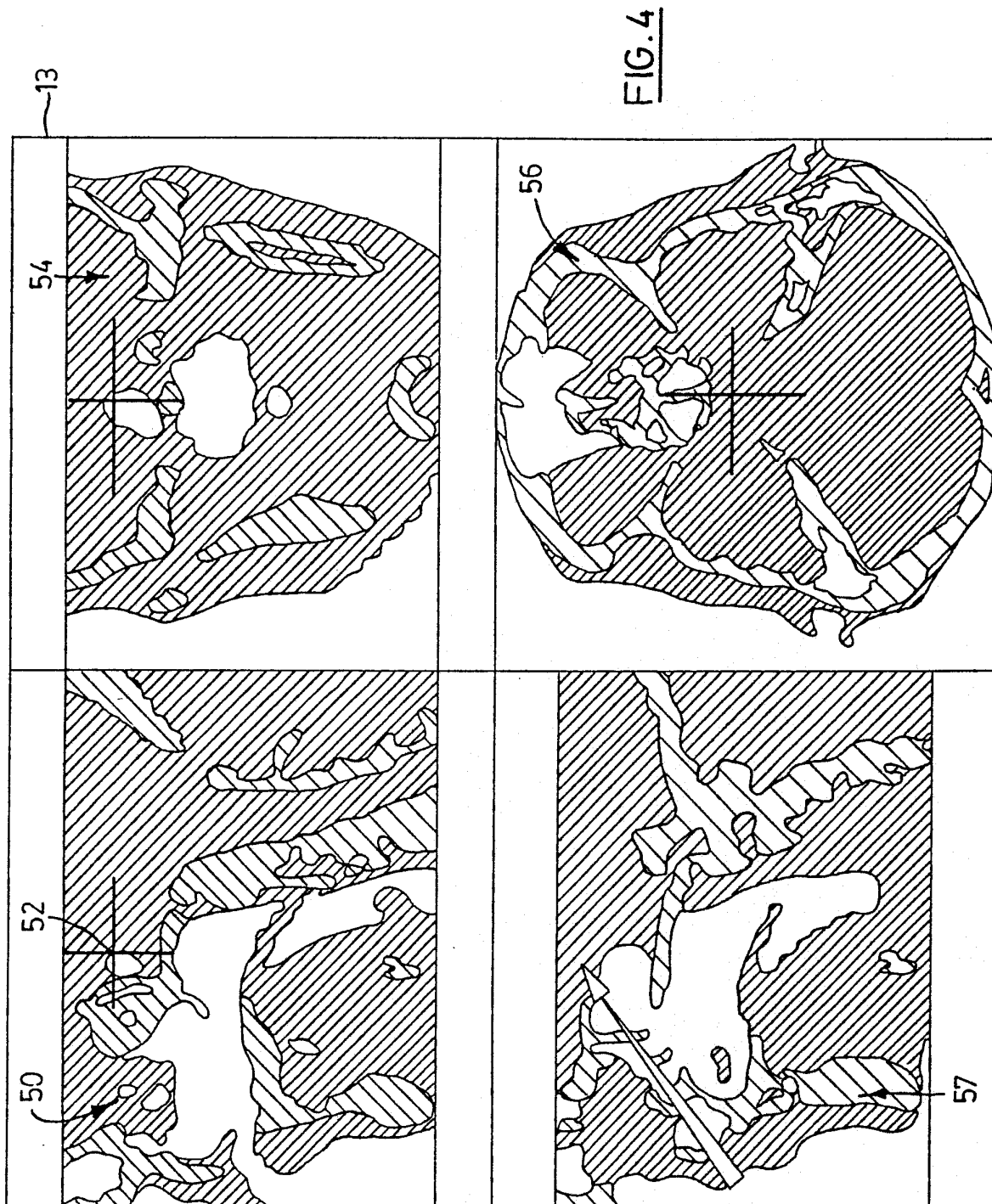

FIG. 3

**SUBSTITUTE SHEET**





**SUBSTITUTE SHEET**

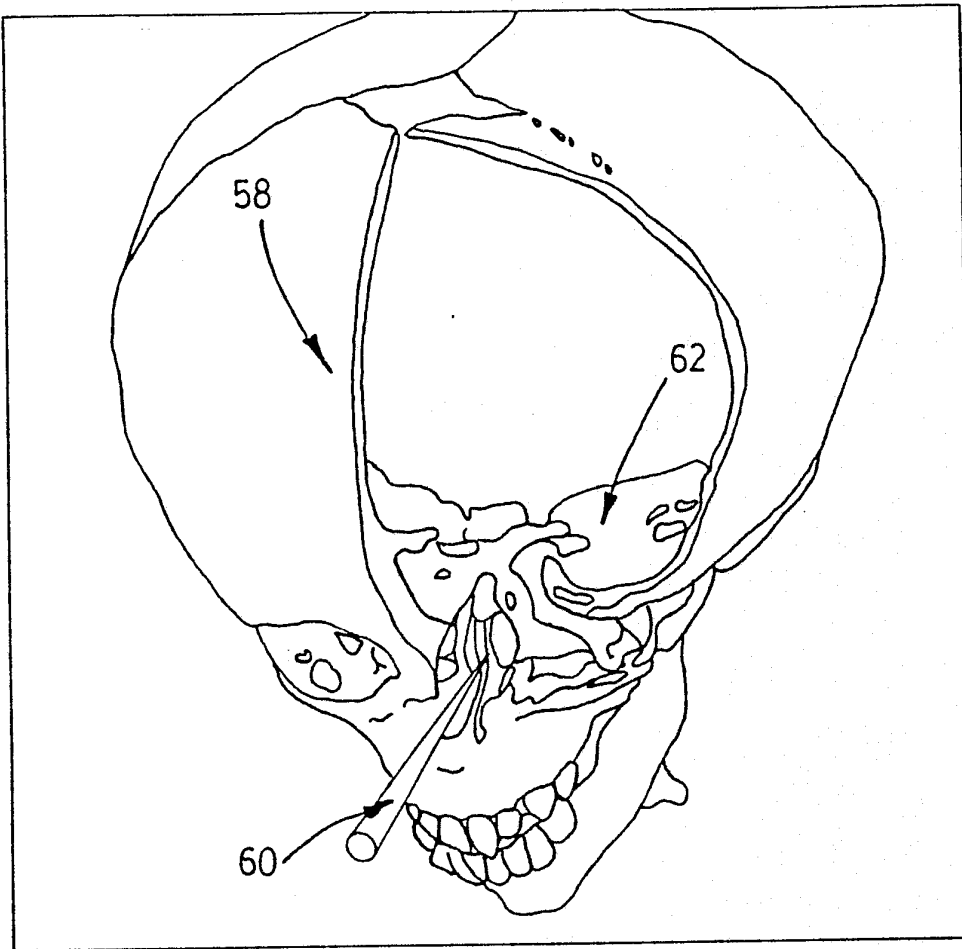

FIG. 5

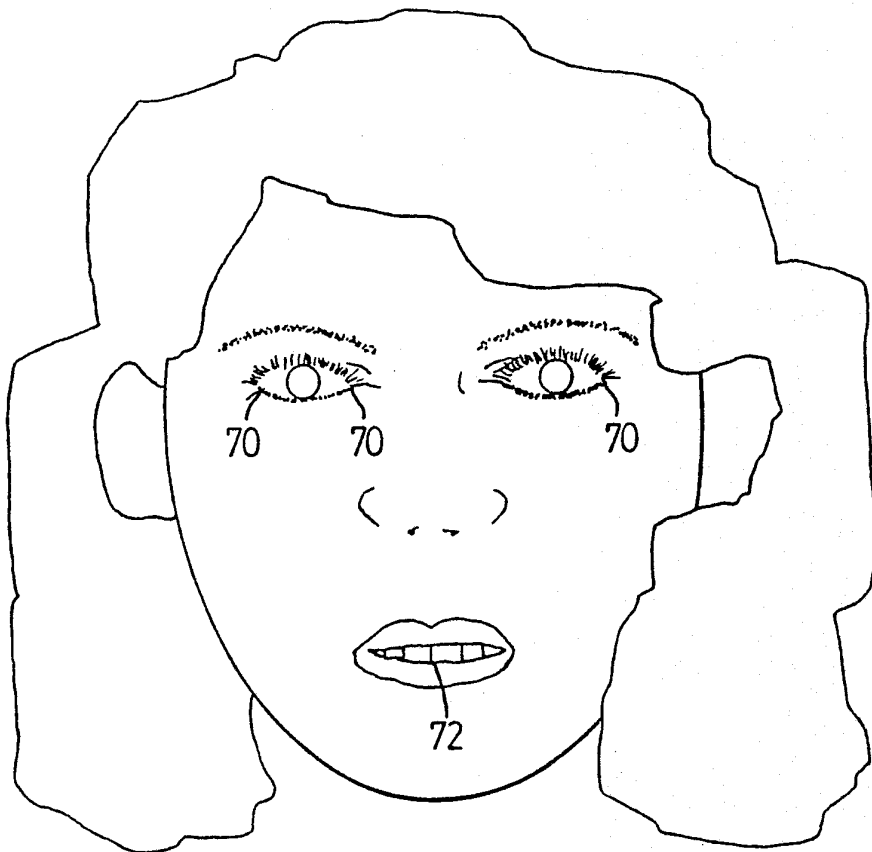
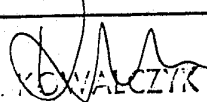

FIG. 6

**SUBSTITUTE SHEET**

# INTERNATIONAL SEARCH REPORT

International Application No PCT/CA 90/00404

<b>I. CLASSIFICATION OF SUBJECT MATTER</b> (if several classification symbols apply, indicate all) <sup>6</sup>		
According to International Patent Classification (IPC) or to both National Classification and IPC		
IPC <sup>5</sup> : G 06 F 15/72, A 61 B 5/11		
<b>II. FIELDS SEARCHED</b>		
Minimum Documentation Searched <sup>7</sup>		
Classification System	Classification Symbols	
IPC <sup>5</sup>	G 06 F 15/72	
Documentation Searched other than Minimum Documentation to the Extent that such Documents are Included in the Fields Searched <sup>8</sup>		
<b>III. DOCUMENTS CONSIDERED TO BE RELEVANT <sup>9</sup></b>		
Category <sup>9</sup>	Citation of Document, <sup>11</sup> with Indication, where appropriate, of the relevant passages <sup>12</sup>	Relevant to Claim No. <sup>13</sup>
X	US, A, 4638798 (C.H. SHELDEN et al.) 27 January 1987 see column 3, lines 26-30; column 3, lines 43-46; column 3, lines 51-56; column 4, lines 16-18; column 4, lines 44-46; column 5, lines 12-15; column 6, lines 13-15; column 6, lines 36-41; column 6, lines 51-54; column 12, lines 53-57; column 13, line 14 - column 14, line 7; column 14, lines 45-60  --	1-19,21-24
P,X	WO, A, 9005494 (C. GIORGI) 31 May 1990 see abstract; page 1, lines 22-26, page 4, lines 27-30; page 5, lines 10-11; page 5, lines 18-19; page 5, line 23 - page 6, line 10; page 6, lines 16-24; page 8, lines 8-15; page 8, lines 25-28; page 9, lines 10-14; page 9, lines 17-22; page 9, line 23 - page 10, line 7; page 10, lines 15-20;  ./.	1-30
<p><sup>10</sup> Special categories of cited documents:</p> <p>"A" document defining the general state of the art which is not considered to be of particular relevance</p> <p>"E" earlier document but published on or after the international filing date</p> <p>"L" document which may throw doubts on priority claim(s) or which is cited to establish the publication date of another citation or other special reason (as specified)</p> <p>"O" document referring to an oral disclosure, use, exhibition or other means</p> <p>"P" document published prior to the international filing date but later than the priority date claimed</p> <p>"T" later document published after the international filing date or priority date and not in conflict with the application but cited to understand the principle or theory underlying the invention</p> <p>"X" document of particular relevance; the claimed invention cannot be considered novel or cannot be considered to involve an inventive step</p> <p>"Y" document of particular relevance; the claimed invention cannot be considered to involve an inventive step when the document is combined with one or more other such documents, such combination being obvious to a person skilled in the art.</p> <p>"&amp;" document member of the same patent family</p>		
<b>IV. CERTIFICATION</b>		
Date of the Actual Completion of the International Search	Date of Mailing of this International Search Report	
7th March 1991	13 APR 1991	
International Searching Authority	Signature of Authorized Officer	
EUROPEAN PATENT OFFICE	 J. S. KOWALCZYK	

III. DOCUMENTS CONSIDERED TO BE RELEVANT (CONTINUED FROM THE SECOND SHEET)		
Category *	Citation of Document, <sup>11</sup> with indication, where appropriate, of the relevant passages	Relevant to Claim No.
	<p>page 10, lines 29-30; page 11, lines 26-30; page 12, lines 5-9; page 12, lines 24-29</p> <p>-----</p>	

ANNEX TO THE INTERNATIONAL SEARCH REPORT  
ON INTERNATIONAL PATENT APPLICATION NO.

CA 9000404

SA 41834

This annex lists the patent family members relating to the patent documents cited in the above-mentioned international search report. The members are as contained in the European Patent Office EDP file on 08/04/91. The European Patent Office is in no way liable for these particulars which are merely given for the purpose of information.

Patent document cited in search report	Publication date	Patent family member(s)	Publication date
US-A- 4638798	27-01-87	None	
WO-A- 9005494	31-05-90	EP-A- 0406352	09-01-91