

AER 17.0.0

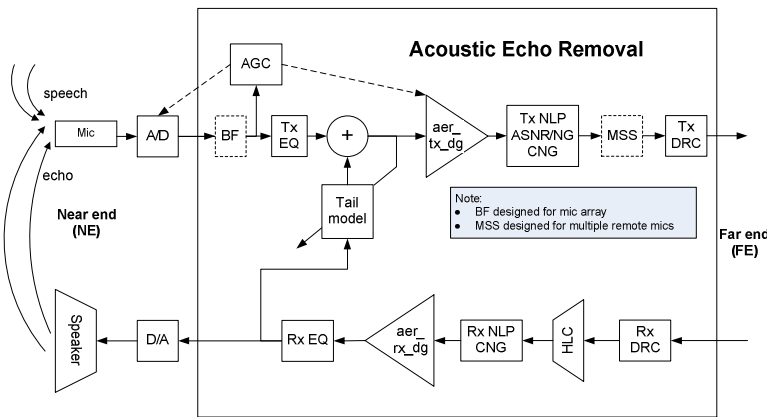

Overview

Acoustic Echo Removal (AER) software component provides real-time digital signal processing algorithms that may be used in products that require efficient handling of acoustic echo combined with loudness and noise control.

The AER software component is packaged in the form of a C callable object code library. The package includes a fully functional example code which may be used for testing and profiling. The example code is provided in source, object and executable formats enabling the fast ramp-up to product integration.

The corner stone of the AER component is TI's field-hardened proprietary high quality full-duplex Acoustic Echo Canceller module. When operating in hands-free configuration, the AER component modules provide for adequate loudness with minimal echo occurrences and maximum full duplex performance. The superior collection of configuration parameters and easy to use support tools allow for a quick scaling between the high-end and low-end products using the same highly optimized code base.

Features

The AER component provides the following features:

- Full-Duplex Acoustic Echo Canceling (AEC)
- Bi-directional Nonlinear Processor (NLP)
- Automatic Microphone Gain Control (AGC)
- Transducer Equalization (EQ)
- Dynamic Range Compression (DRC)
- Adaptive Spectral Noise Reduction (ASNR)
- High Level Compensation (HLC)
- Noise Guard (NG)
- Bi-directional Comfort Noise Generator (CNG)
- Double-talk/Coherence/Howling Detection
- Fixed Beamforming (BF) (Refer to white paper)
- Multi-Microphone/Source Selection (MSS)
- Design tools
 - Equalizer design tool
 - DRC configuration tool
 - Non-linear echo path analysis tool
 - Parameter configuration tool (includes test signals)
 - BF fractional delay filter design tool
- Operating modes:
 - Hands-free, Handset, Headset, Group-listen

Technical Specifications

- Frequency domain adaptive filter
 - block FFT, normalized LMS
 - configurable length (typically 200ms in hands-free)
- High precision fixed point
 - 16-/32-/64-bit fixed point, block-floating point
- Frequency domain NLP (FDNLP)
 - up to 400ms room reverberation (with 200ms filter)
- Sampling rates: 8kHz, 16kHz full band or band-split
- Convergence speed: < 0.5s (20dB on –10dBm CSS)
- Echo path change recovery: < 1s
- Bi-Quad parametric EQ
 - five bands (configurable Gain, F_c , Q)
 - additional HP/LP filters (configurable F_c)
 - low noise lattice structure with configurable ordering for maximum dynamic range
- Full-band and multi-band DRC with fast signal limiter
- ASNR
 - configurable noise reduction in dB
 - independent configuration for multiple frequency bands
 - configurable quality/delay (3/4/5/6ms)
 - automatically disengages in low noise environments
- Standards compliance and support
 - ITU-T G.167/P.340, P.310/311/341/342
 - TIA-810A/B, TIA-920
 - IETS 300 245-2/-3/-5/-6, TBR 8, TBR 10

Applications

Typical applications of AER component are:

- speakerphones
- IP Phones
- ISDN Phones
- mobile phones
- cordless phones
- conferencing systems
- high quality USB/BT headsets
- intercom systems
- hands-free car kits
- emergency communication systems

Supported Architectures

- C55x, C64x+, C674x
- ARM Cortex-A8/Neon

Resource Requirements

AER configured as single microphone, full-duplex hands-free operation, 200ms filter, 16kHz full band, spectrally matched CNG, Tx/Rx EQ, HLC, ASNR, Rx DRC all enabled.

CPU	MCPS (peak/avg)		Memory (kB = 1000 bytes, Dat: scratch / permanent)
	AER	BF	
C55x (flush cache every call)	AER	Tx (AER&AGC): 52/36 Rx (AER&DRC): 11/10	Program: 55kB Data: 16kB/39kB
	BF	8.2/8.2	Program: 2.1kB Data: 1.0kB/0.7dB
C64x+/C674x (flush cache every call)	AER	Tx (AER&AGC): 42/31 Rx (AER&DRC): 8/8	Program: 110kB Data: 16kB/39kB
	BF	1.3/0.9	Program: 3.9kB Data: 1.0kB/0.7dB
ARM Cortex-A8 with Neon	AER	Tx (AER&AGC): 69 Rx (AER&DRC): 16	Program: 101kB Data: 16kB/39kB
	BF	5.3	Program: 3.2kB Data: 1.0kB/0.7dB