



TECHNOTES

Connecting Direct Touch RS 422 to a F2-UNICON RS232 to RS422/485 Converter.

Product group: Direct Touch
 Information Type: Communications
 Last revised : 8 Nov, 2002

**Touch Panel
RS 422 terminal**

F2-UNICON

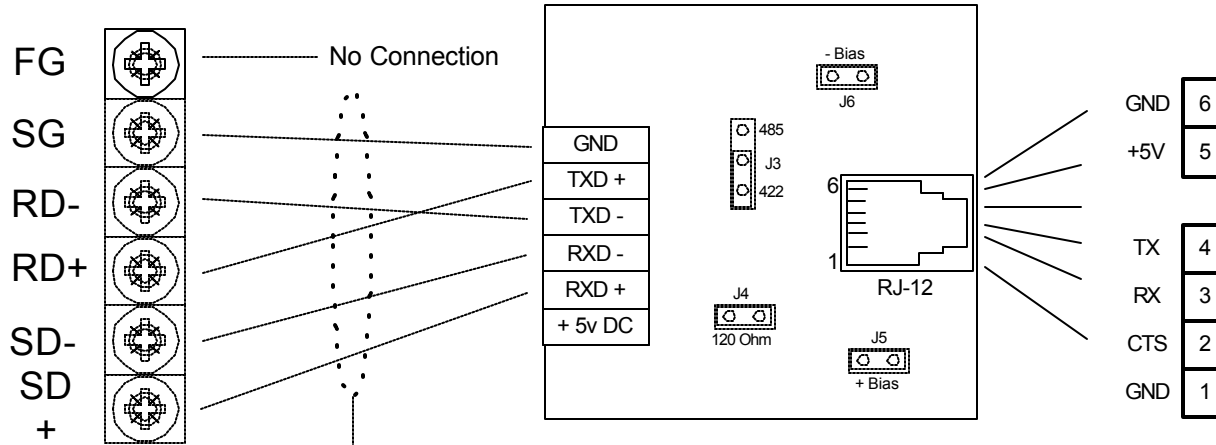

You provide RS 422 cable.
 We recommend Belden 9729
 Or Equivalent

* Refer to the FA-UNICON
 documentation for jumper positions.

The F2-Unicon ships with a 1ft. flat cable with RJ12 (6 conductor) connectors at each end. For connecting to a Directlogic PLC.

The FA-CABKIT can also be used for connecting the Converter to a DirectLogic PLC.

**Touch Panel
RS 422 Configuration**

Connected Device	PLC
Communication Rate	9600
Parity	Even
Stop Bit	1
Data Length	8

Note: The Baud rate and Parity must match between the Touch Panel and the PLC.

Depending on distance it may be necessary to increase the Timeouts and Retries in the Touch Screen. They can be accessed by selecting the Detail tab when configuring the comm port on the touch panel.