



TECHNOTES

Wiring Diagram for NPN and PNP 2 wire sensors with the D2-16ND3-2

Product group: 205 series
Information Type: 16 point DC input module
Last revised: 15 Feb, 2002

Document Name: NPN_PNP 2 wire sensors.vsd

2 Wire sensor Layout

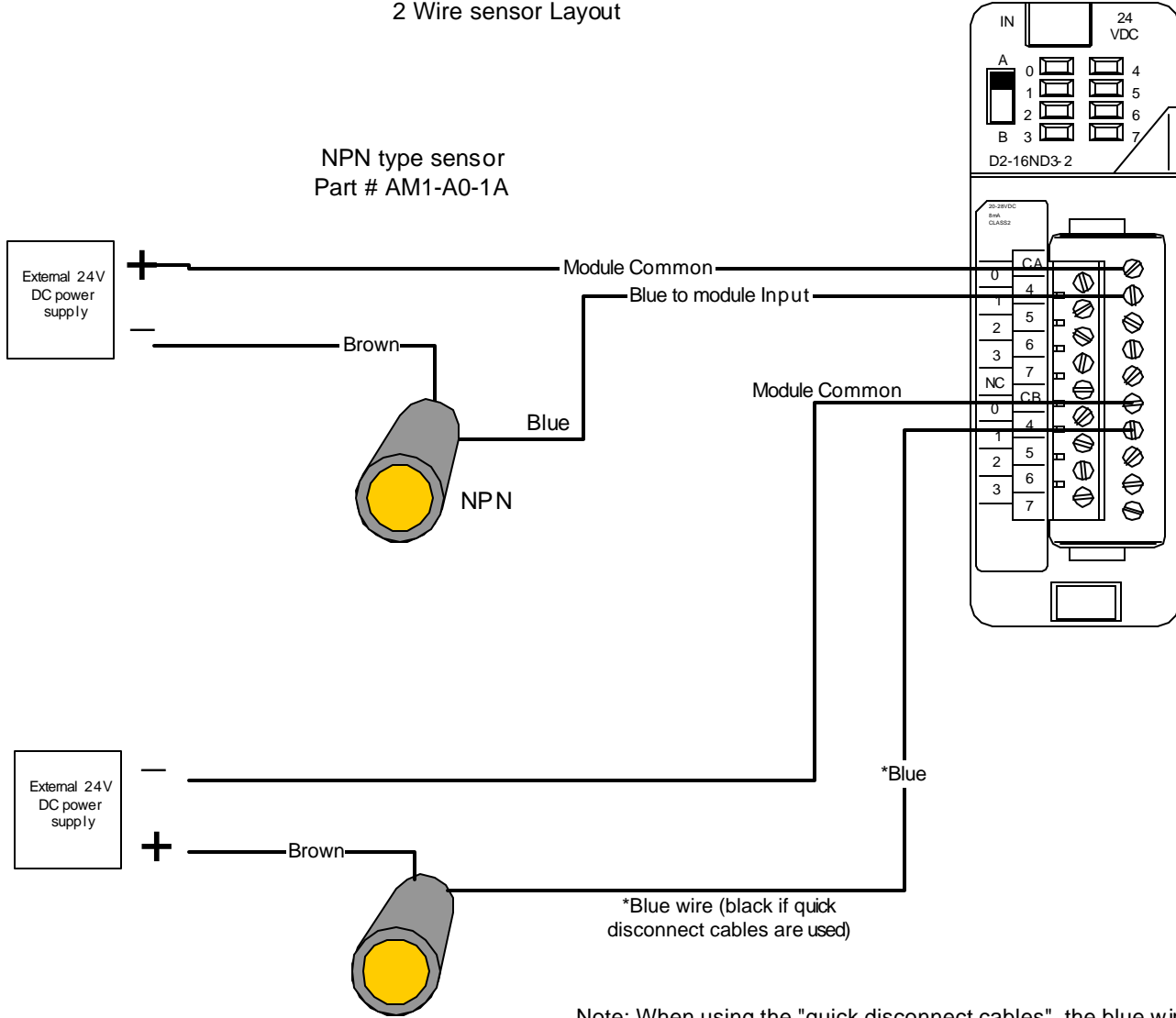

Note: When using the "quick disconnect cables", the blue wire will be substituted for the black wire

Please refer to our tech support website for more info on sensors. The FAQ section may have information that can help. Click on this link

[FAQ](#)

Question : What output do I need? NPN or PNP?

Answer: This is determined by the device you are connecting the sensor to. Most ADC PLC modules (except 305 series) allow NPN or PNP sensors to be connected.

Note:

Sinking = provides a path to supply common(-)
Sourcing = provides a path to supply source(+)