

# Cl(16): BiVector+half-Spinor E8 and TriVector Fr3(O) E8 gives 8D and 4D Kaluza-Klein Lagrangian Fr3(O) gives Cl(1,25) AQFT

Frank Dodd (Tony) Smith, Jr. - August 2018

## Abstract

Our Universe originated and evolves according to David Finkelstein's process of Iteration of Real Clifford Algebras. Cl(16) contains E8 (as BiVectors + half-Spinors) and 10 copies of Fr3(O) (as TriVectors). The remaining  $65,536 - 248 - 560 = 64,728$  elements carry Information in Penrose-Hameroff Microtubule Quantum Consciousness. Fr3(O) gives 26D World-Line=String Cl(1,25) and AQFT based on E8 Lagrangian with Schwinger Sources whose Internal QuasiCrystal Structure encodes Symmetric Space - Complex Bounded Domain - Shilov Boundary data for calculation of Force Strengths, Particle Masses, etc, and whose External Indra Net BlockChain Structure describes the Unity of Our Universe as a Quantum Consciousness in the Bulk of the Complex Bounded Domain that mirrors our individual Quantum Consciousnesses in the Shilov Boundary that is our Physical Spacetime.

## Table of Contents

page 3 ... **Origin of Our Universe = David Finkelstein Iteration of Clifford Algebras**

$\emptyset \rightarrow Cl(\emptyset) = 0 \rightarrow Cl(0) = 1 \rightarrow Cl(1) = 2 \rightarrow Cl(2) = 4 \rightarrow Cl(4) = 16 \rightarrow$   
 $\rightarrow Cl(16) = 65,536 = 256 \times 256 = Cl(8) \times Cl(8)$

Cl(8) and Cellular Automata

page 7 ... **Cl(16) BiVectors + half-Spinors = E8**

which gives 8D Lagrangian from 240 Root Vectors

E8 / D8 = First-Generation Fermion Particles and AntiParticles

D8 / D4 x D4 = 8D Spacetime = Superposition of 8 E8 Lattices

D4cnfg = U(2,2) Conformal Gravity+Dark Energy and ghosts of Standard Model

page 24 Conformal Structure gives ratio DE : DM : OM = 75 : 21 : 04

page 29 E8 Real Forms and Evolution of Our Universe  
with Particle Creation during Non-Unitary Octonionic Inflation



page 39 Pioneer Anomaly and Uranus Rotation Axis

page 44 Kepler's Polyhedra-Planet Correspondence

page 52 Conformal Gravity + Dark Energy and Warp Drive

	D4sm = Standard Model and ghosts of Conformal Gravity
	8D Lagrangian gives 4D Lagrangian with M4 x CP2 Kaluza-Klein ( CP2 = SU(3) / U(1)xSU(2) )
page 60	Coleman-Mandula
page 61	UltraViolet Finiteness
page 62	Chirality Spin-Statistics
page 63	Spinor AntiCommutators - F4 and E8
page 68	4D Lagrangian has Fermion Generations 2 and 3 and Higgs
page 71	Nambu - Jona-Lasinio 3-state Higgs - Truth Quark System
page 72 ...	<b>C(16) TriVectors = 10 copies of Fr3(O)</b>
	which gives 26D Theory of World-Lines = Strings and Cl(1,25)
page 79	AQFT = Completion of Union of Tensor Products of Cl(1,25) = = Third Grothendieck Universe = Hyperfinite II1 von Neumann factor
page 81	spin-2 traceless symmetric 24x24 = Bohm-Sarfatti Quantum Potential
page 90	Sutherland-Sarfatti Lagrangian for Bohm Quantum Potential
page 92	Sarfatti-Bohm-Penrose-Hameroff Microtubule Quantum Consciousness
page 104	DNA, Microtubules, Cl(16) and $2^{16} = 65,536$
page 108	Microtubules and Consciousness Decpherece Time
page 113 ...	<b>Schwinger Sources Internal QuasiCrystal Structure</b>
page 117	Schwinger Source External Black Hole Structure
page 118	Schwinger Source Geometry for Fermions
page 124	Fermion Masses
page 136	Kobayashi-Maskawa Parameters
page 146	Neutrino Masses Beyond Tree Level
page 151	Schwinger Source Geometry for Gauge Bosons
page 155	Higgs and Weak Boson Masses
page 160	Proton-Neutron Mass Difference
page 161	Pion as Sine-Gordon Breather
page 166	Planck Mass as Superposition Fermion Condensate
page 167	Quantum Bohmion
page 168	Schwinger Source Green's Functions from Kernel Functions
page 174	Monster Group of Planck-scale Lattice Cell modulo Leech Lattice
page 176	Tachyon Virtual Particle/AntiParticle Cloud= $10^{(-24)}$ cm Schwinger Source
page 187	Schwinger Source Jewels of Indra Net BlockChain Structure
page 192	Results of Calculations of Force Strengths, Particle Masses, etc
page 193	Nambu - Jona-Lasinio Higgs - Truth Quark System with 3 Mass States and observations at Fermilab and the LHC
page 194 ...	Appendix: <b>Angkor Wat and Giza Pyramids - Sphinx</b>

All Universes begin as Quantum Fluctuations of the Empty Set = Void by Quantum Fluctuation of Compact E8(-248) Real Form of E8 which is the First Grothendieck Universe and they all evolve according to David Finkelstein's Iteration of Real Clifford Algebras:

$n = 0$	$\emptyset$	= Void
$n = 1$	$\{\emptyset\}$	= Cl(0)
$n = 2$	$\emptyset \quad \{\emptyset\}$	= Cl(1)
$n = 4$	$\emptyset \quad \{\{\emptyset\}\} \quad \{\emptyset \& \{\emptyset\}\} \quad \{\emptyset\}$	= Cl(2)
$n = 16$		= Cl(4)
$n = 65,536$		= Cl( $2^4=16$ ) = Cl(16)
$n = 2^{65,536}$		= Cl( $2^{16}=65,536$ ) = Cl(65,536)

As the Finkelstein Iteration grows from the Void to Cl(0) to Cl(Cl(0)) to Cl( Cl ... n times ... Cl) the number of elements n grows from 0 to  $2^0 = 1$  to  $2^1 = 2$  to  $2^2 = 4$  to  $2^4 = 16$  to  $2^{16} = 65,536$  to  $2^{65,536}$  ... and beyond ...

so

it is clear that Cl(16) is the last stage of the process that is manageable for construction of a Physics Model based on Hereditarily Finite Sets which is the Second Grothendieck Universe.

What Structures of Cl(16) lead to a useful Physics Model ?



**CI(16) = tensor product CI(8) x CI(8) of two copies of CI(8)**

A representation of each 256-dim CI(8) by the 256 Elementary Cellular Automata shows how specific Cellular Automata correspond to specific elements of CI(8) preserving Grading Structure:

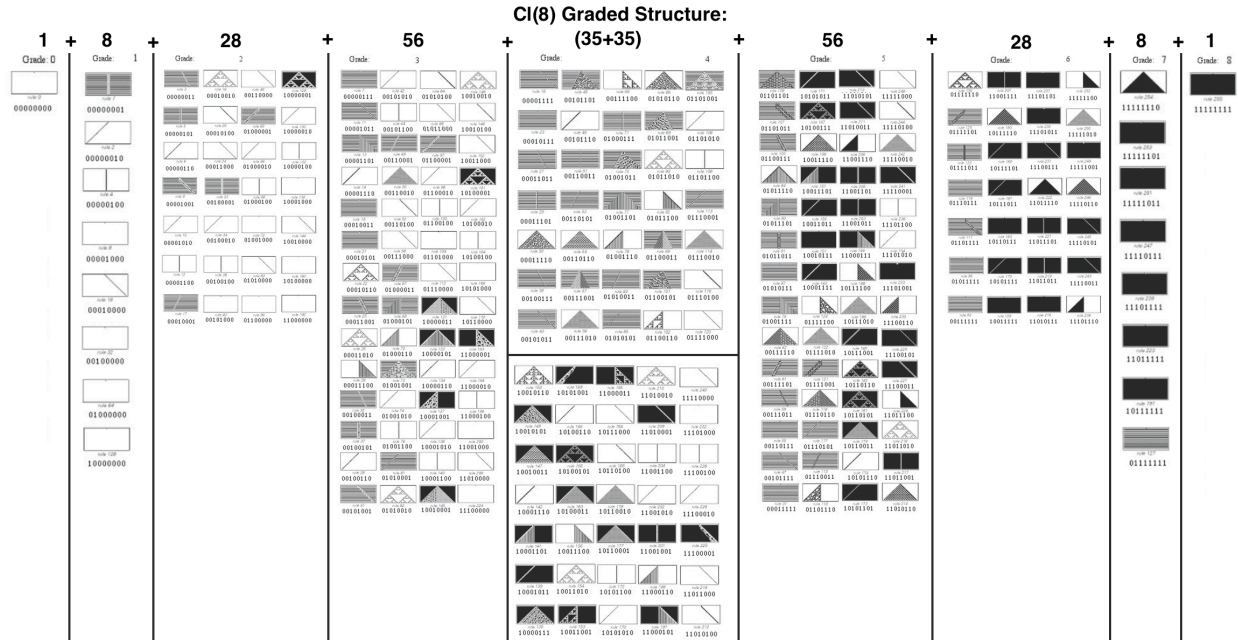

Ron Eglash (in his book "African Fractals" (Rutgers 1999) and on his web site) says: "... a historical path for base-2 calculation ... begins with African divination ...".

African IFA Divination is based on a  $2^4 = 16$  Tetragrams and a  $16 \times 16$  Matrix of Tetragram Pairs = 256 Odu with 16 Diagonal Odu and 240 Off-Diagonal Odu corresponding to the  $2^8 = 256$  elements of the Real Clifford Algebra CI(8)

Raymond Aschheim (email May 2015) said, about **Cellular Automata (CA)**: "... An elementary CA is defined by the next value (either 0 or 1) for a cell, depending on its ... value, and the ... value of it[s] left and of it[s] right neighbor cell (it is one dimensional, and involve only the first neighbors, and the cell itself) ... So the next value depends [on] 3 bits ... eight possible combination of three bits, and for each ... combination... the next value is either zero or one. So the[re] are **256 ... CAs ...**".

**28**

**8**

Grade 0

**1**

Grade 0

**Cellular Automata (CA):**  
**The 256 CAs correspond to the 256-dim Cl(8) Real Clifford Algebra:**

**8+28+16 = 52 F4**

**16**

**Cl(8) Primitive Idempotent Has 16 Terms**

$$I = (1/2)(1 + e_1 e_2 e_3 e_4 e_5 e_6 e_7 e_8) (1/2)(1 + e_1 e_2 e_3 e_4 e_5 e_6 e_7) (1/2)(1 + e_1 e_2 e_3 e_4 e_5 e_6) (1/2)(1 + e_1 e_2 e_3 e_4 e_5) = (1/16)(1 + e_1 e_2 e_3 e_4 e_5 e_6 e_7 e_8 + e_1 e_2 e_3 e_4 e_5 e_6 e_7 + e_1 e_2 e_3 e_4 e_5 e_6 + e_1 e_2 e_3 e_4 e_5 + e_1 e_2 e_3 e_4 + e_1 e_2 e_3 + e_1 e_2 + e_1 + 1)$$

corresponding to 16 of the 256 Cellular Automata

- $e_1 = e_{1245678}$  11111111
- $e_2 = e_{2728} = e_{3468} + e_{478}$  11100101 11101001
- $e_3 = e_{2258} = e_{3249} + e_{5618} + e_{78}$  10100110 10101011
- $e_4 = 1$  00000000
- $e_5 = e_{5712} = e_{1345} + e_{6123}$  00101101 00101101
- $e_6 = e_{6071} = e_{7284} + e_{2456} + e_{3567}$  01010101 01011010

**Tensor Product Cl(8) x Cl(8) = Cl(16)**  
**(F4 in Cl(8)) x (F4 in Cl(8)) =**  
**= 8x8 + 28x1 + 1x28 + 16x16 =**  
**= 120 Cl(16) BIVectors + (128 + 128) Cl(16) Spinors**  
**120 Cl(16) BIVectors + 128 Cl(16) Half-Spinors = E8**

**Cl(8) Triality**

**Grade 1**

**Grade 2**

**Grade 3**

**Grade 4**

**Grade 5**

**Grade 6**

**Grade 7**

**Grade 8**

# Cl(16) BiVectors and half-Spinors

By 8-Periodicity of Real Clifford Algebras  
 $Cl(16) = \text{tensor product } Cl(8) \times Cl(8)$

The 28 Grade-2 BiVectors of Cl8) have two different Physical Interpretations:

16x16 Matrix Representation

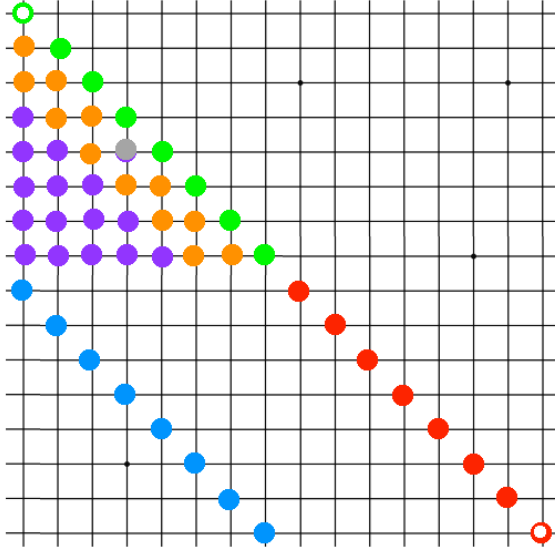

15 Purple = Spin(2,4) = SU(2,2) Gauge Bosons  
 1 Grey = U(1) of U(2,2) Propagator Phase  
 12 Orange = Standard Model Ghosts

16x16 Matrix Representation

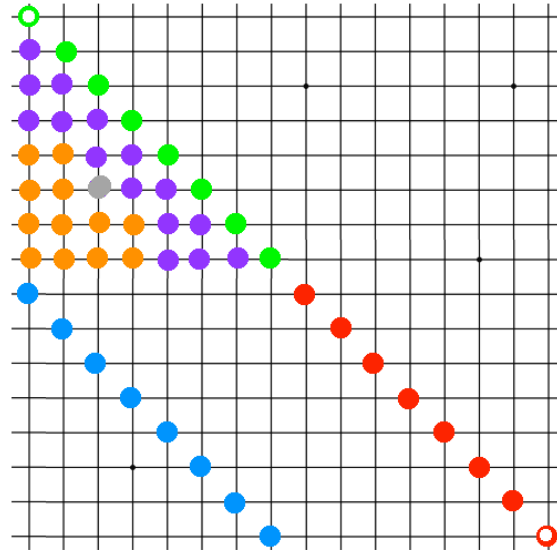

12 Orange = SU(3) x SU(2) x U(1) Gauge Bosons  
 1 Grey = U(1) of U(3) Propagator Phase  
 15 Purple = Gravity + Dark Energy Ghosts

8 Vector (blue) and 8+8 Spinor (green and red) Physical Interpretations are the same.

One 52-dim F4 is represented within the first CI(8) by

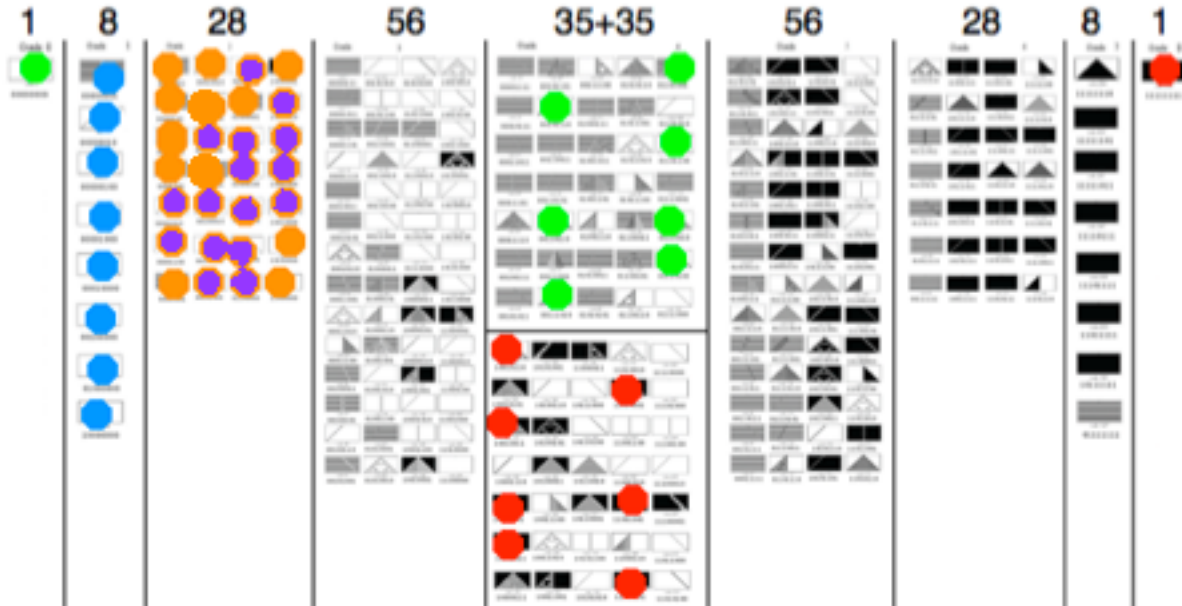

8 Grade-1 Vectors (blue) +  
 28 Grade-2 BiVectors (purple and gold) +  
 16 Spinors (1 Grade-1 + (7+7)Grade-4 + 1 Grade-8) (green and red)

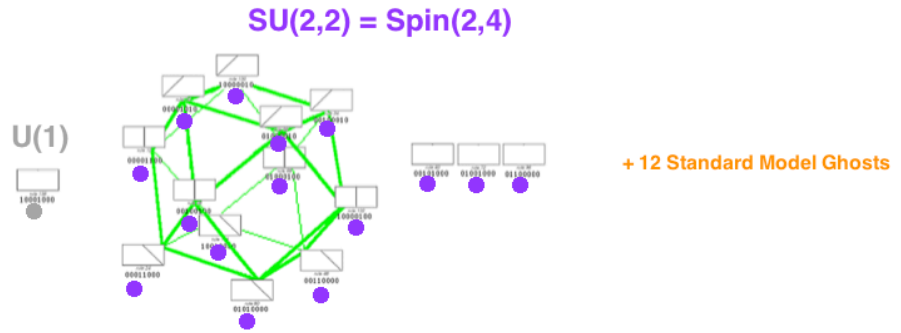
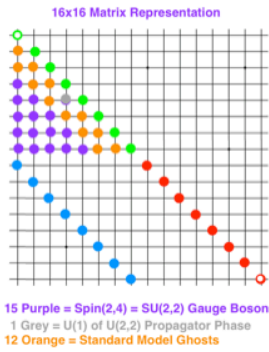

In the First CI(8) the (purple) SU(2,2) = Spin(2,4) Conformal Gravity+Dark Energy has effective Gauge Group action

so

denote the First CI(8) and F4 by CI(8)gr and F4gr and by the color purple

**52D F4gr = 8D CI(8)gr Vectors + 28D CI(8)gr BiVectors + (8+8)D CI(8)gr Spinors**



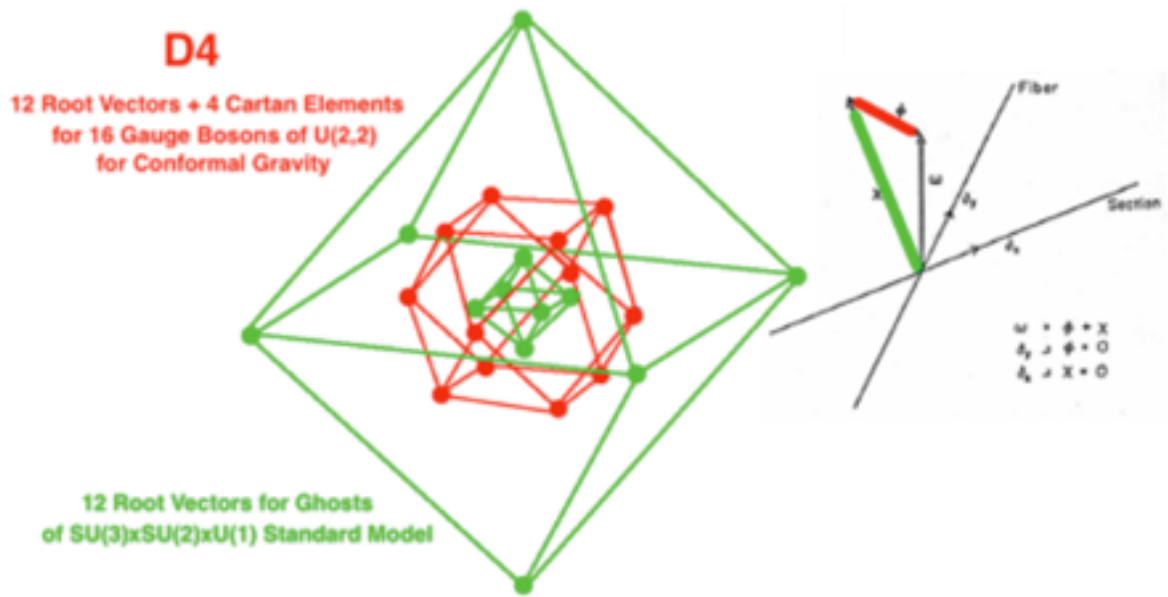

Jean Thierry-Mieg in J. Math. Phys. 21 (1980) 2834-2838 said:

“... The ghost and the gauge field:

The single lines represent a local coordinate system  
of a principal fiber bundle of base space-time.

The double lines are 1 forms.

The connection of the principle bundle  $w$  is assumed to be vertical.

Its contravariant components  $\Phi$  and  $X$  are recognized, respectively,  
as the Yang-Mills gauge field and the Faddeev-Popov ghost form ...”.

Steven Weinberg in The Quantum Theory of Fields Volume II Section 15.7 said:  
 "... there is a beautiful geometric interpretation of the ghosts and the BRST symmetry ...  
 The gauge fields  $A_a^\mu$  may be written as one-forms  $A_a = A_{a\mu} dx^\mu$ , where  $dx^\mu$   
 are a set of anticommuting c-numbers. ... This can be combined with the ghost to  
 compose a one-form  $\mathbf{A}_a = A_a + w_a$  in an extended space.  
 Also, the ordinary exterior derivative  $d = dx^\mu d/dx^\mu$  may be combined with the BRST  
 operator  $s$  to form an exterior derivative  $D = d + s$  in this space,  
 which is nilpotent because  $s^2 = d^2 = sd + ds = 0 \dots$ ".

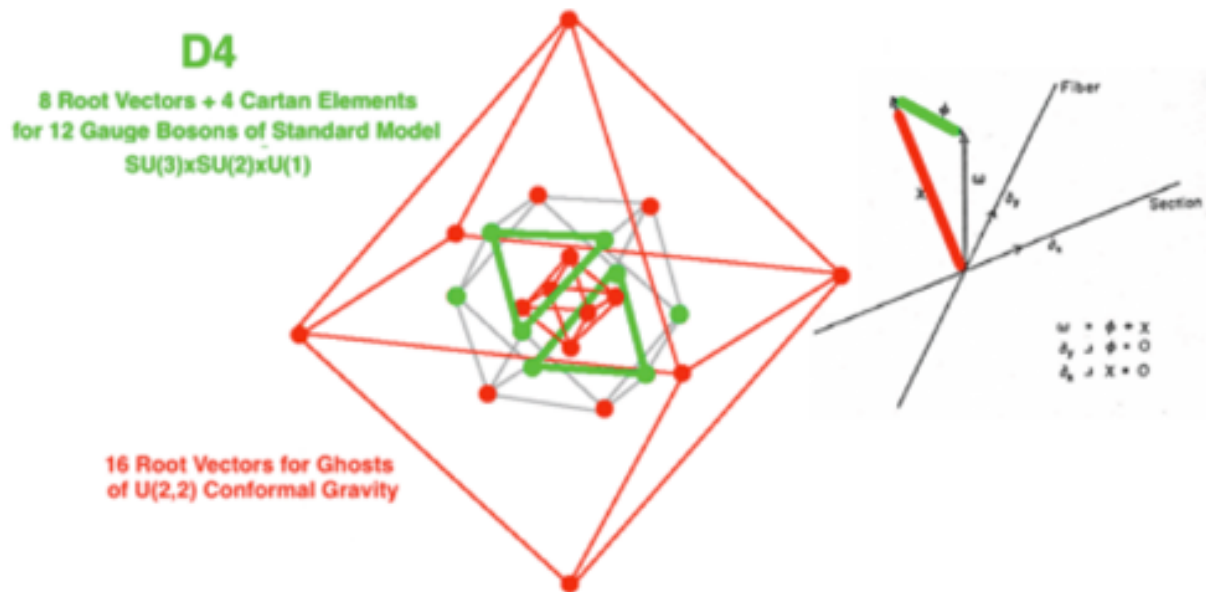

A second 52-dim F4 is represented within the second Cl(8) by

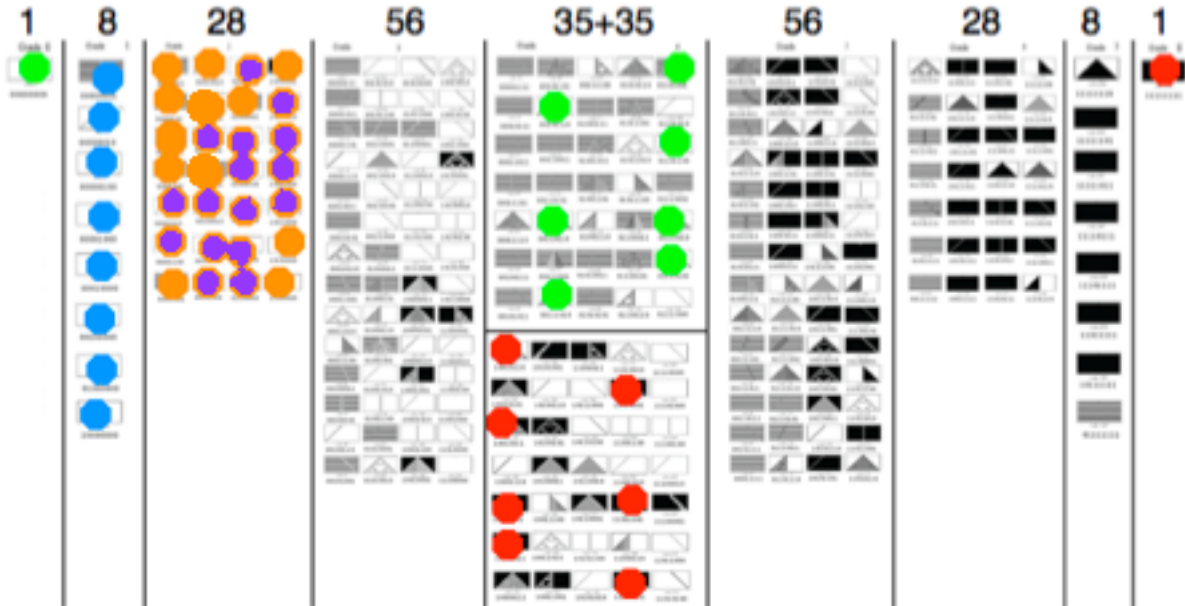

8 Grade-1 Vectors (blue) +  
 28 Grade-2 BiVectors (gold and purple) +  
 16 Spinors (1 Grade-1 + (7+7)Grade-4 + 1 Grade-8) (green and red)

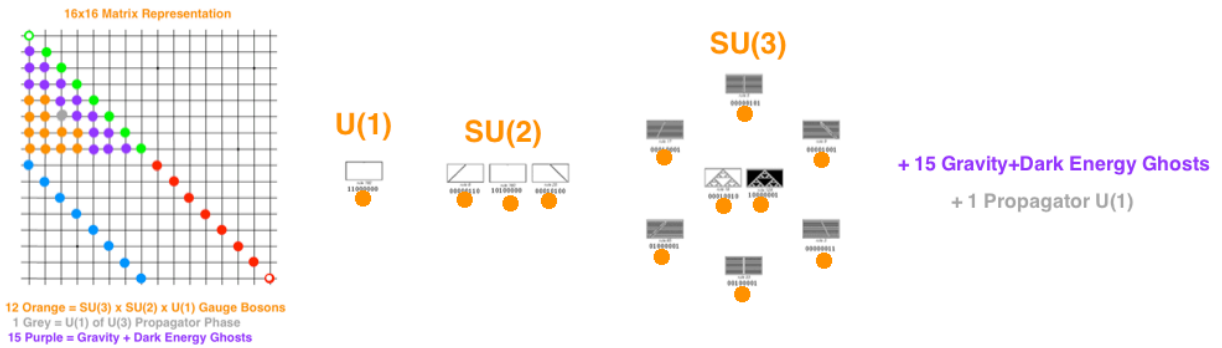

In the Second Cl(8) the (gold) U(1)xSU(2)xSU(3) Standard Model  
 has effective Gauge Group action

so

denote the Second Cl(8) and F4 by Cl(8)sm and F4sm and by the color gold.

52D F4sm = 8D Cl(8)sm Vectors + 28D Cl(8)sm BiVectors + (8+8)D Cl(8)sm Spinors

Based on the tensor product

$$\text{Cl}(8) \times \text{Cl}(8) = \text{Cl}(16)$$

and

the  $\text{Cl}(8)$  graded structure

$$1 \quad 8 \quad 28 \quad 56 \quad 35+35 \quad 56 \quad 28 \quad 8 \quad 1$$

we have

$\text{Cl}(16)$  BiVectors =

$$\text{Cl}(8) \text{ BiVectors} + \text{Cl}(8) \text{ BiVectors} + (\text{Cl}(8) \text{ Vectors} \times \text{Cl}(8) \text{ Vectors})$$



$$28 + 28 + 64 = 120 = \text{D8 Lie Algebra}$$

$\text{Cl}(16)$  Spinors =

$$(\text{Cl}(8) \text{ +half-Spinors} + \text{-half-Spinors}) \times (\text{Cl}(8) \text{ +half-Spinors} + \text{-half-Spinors})$$



$$8 \times 8 + 8 \times 8 + 8 \times 8 + 8 \times 8 = 256$$

$$64 + 64 = 128 = \text{Cl}(16) \text{ ++quarter-Spinors} + \text{Cl}(16) \text{ --quarter-Spinors}$$

$$\begin{aligned}
 &120 = \text{Cl}(16) \text{ BiVectors} \\
 &+ \\
 &128 = \text{Cl}(16) \text{ ++quarter-Spinors} + \text{Cl}(16) \text{ --quarter-Spinors} \\
 &= \\
 &248\text{-dim E8 with 240 Root Vectors}
 \end{aligned}$$

248-dim E8 in  $CI(16)$  has 240 Root Vectors -  
 - first shell of 8-dim E8 Lattice.  
 Since it is hard to visualize points on  $S^7$  in 8-dim space,  
 I prefer to represent the 240 E8 Root Vectors  
 in this 2D representation by Ray Aschheim

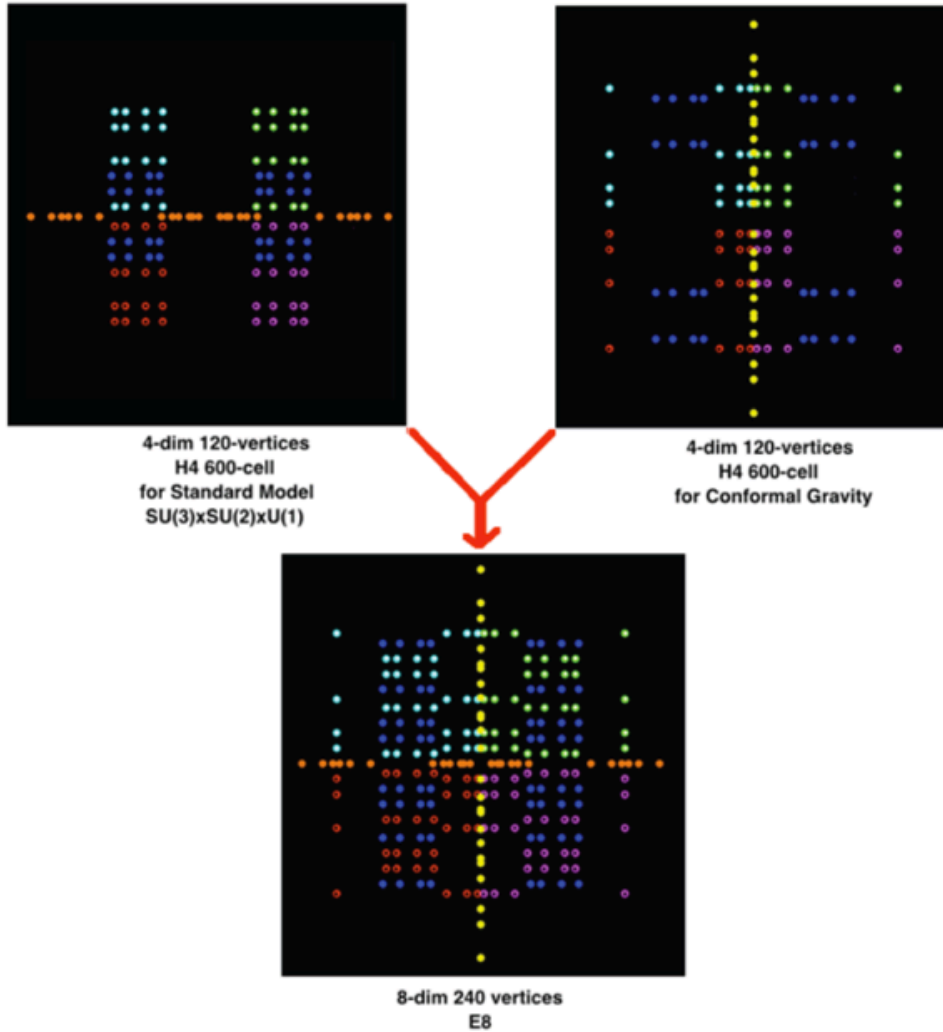

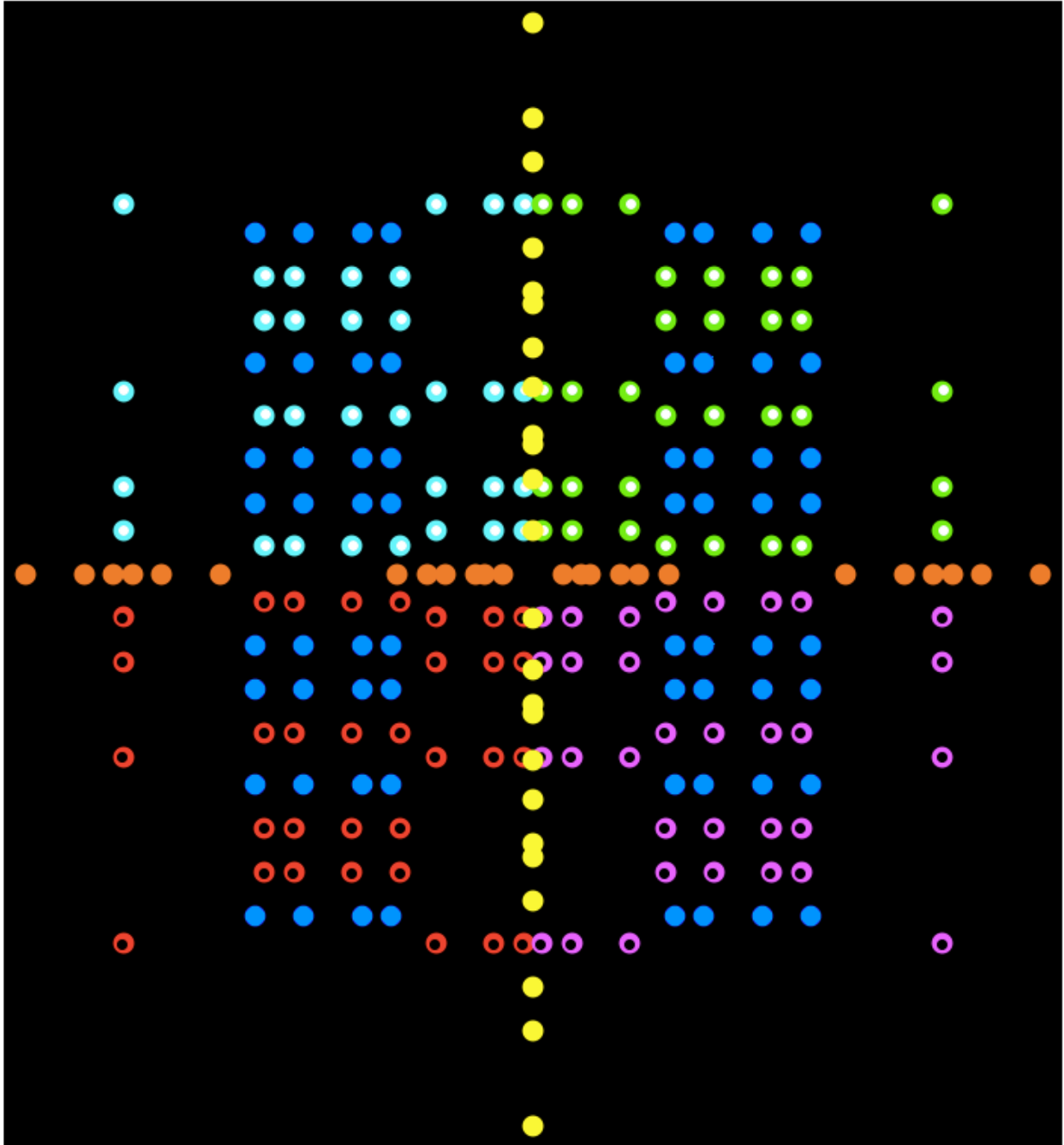

To understand the Geometry related to the 240 E8 Root Vectors, consider that  
 248-dim E8 = 120-dim Spin(16) D8 + 128-dim half-spinor of Spin(16) D8  
 240 E8 Root Vectors = 112 D8 Root Vectors + 128 D8 half-spinors  
 112 D8 Root Vectors = 24 D4 (orange) + 24 D4 (yellow) + 64 (blue)  
 128 D8 half-spinors = 128 elements of E8 / D8

Green and Cyan dots with white centers (32+32 = 64 dots) and  
 Red and Magenta dots with black centers (32+32 = 64 dots)  
 correspond to the 128 elements of E8 / D8.

How do the 240 E8 Root Vectors  
fit into a Realistic Lagrangian ?

$$\int_{\text{Base Manifold Spacetime}} \text{Lagrangian} = \int_{\text{D8 / D4xD4}} \left( \text{Gauge Bosons and Ghosts}_{\text{D4xD4}} + \text{Spinor Fermions}_{\text{E8 / D8}} \right)$$

The 64 Green and Cyan Root Vectors represent the  
First Generation Fermion Particles of E8 / D8

Each of 8 Particles have

$8 = 4+4$  M4 x CP2 Kaluza-Klein components

so they are represented by  $8 \times 8 = 64$  Root Vectors



The 8 Fermion Particle Types  $\{\text{Nu}, \text{rDQ}, \text{gDQ}, \text{bDQ}; \text{bUQ}, \text{gUQ}, \text{rUQ}, \text{E}\}$  are represented by the real part  $\text{RP1} \times \text{S7}$  of the Complex Shilov Boundary  $\text{S}$  of the 32-real-dim  $\text{V}$  non-tube type.bounded Domain  $(\text{CxO})\text{P2}$  of the EIII Symmetric Space  $\text{E6} / \text{Spin}(10) \times \text{U}(1)$ .

The bounded Domain is in a subspace of  $\text{J3}(\text{CxO})$  and  $\text{S}$  is a fiber space with fiber  $\text{RP1} \times \text{S7}$  (Real part for Particles) and base space  $\text{S9}$  with fibration  $\text{S1} \rightarrow \text{S9} \rightarrow \text{CP4}$  that contains a  $\text{RP1} \times \text{S7}$  (for AntiParticles, in the Complex part) that is isomorphic to the fibre  $\text{RP1} \times \text{S7}$  (Real part for Particles).



Here is how they fit into the Lagrangian:

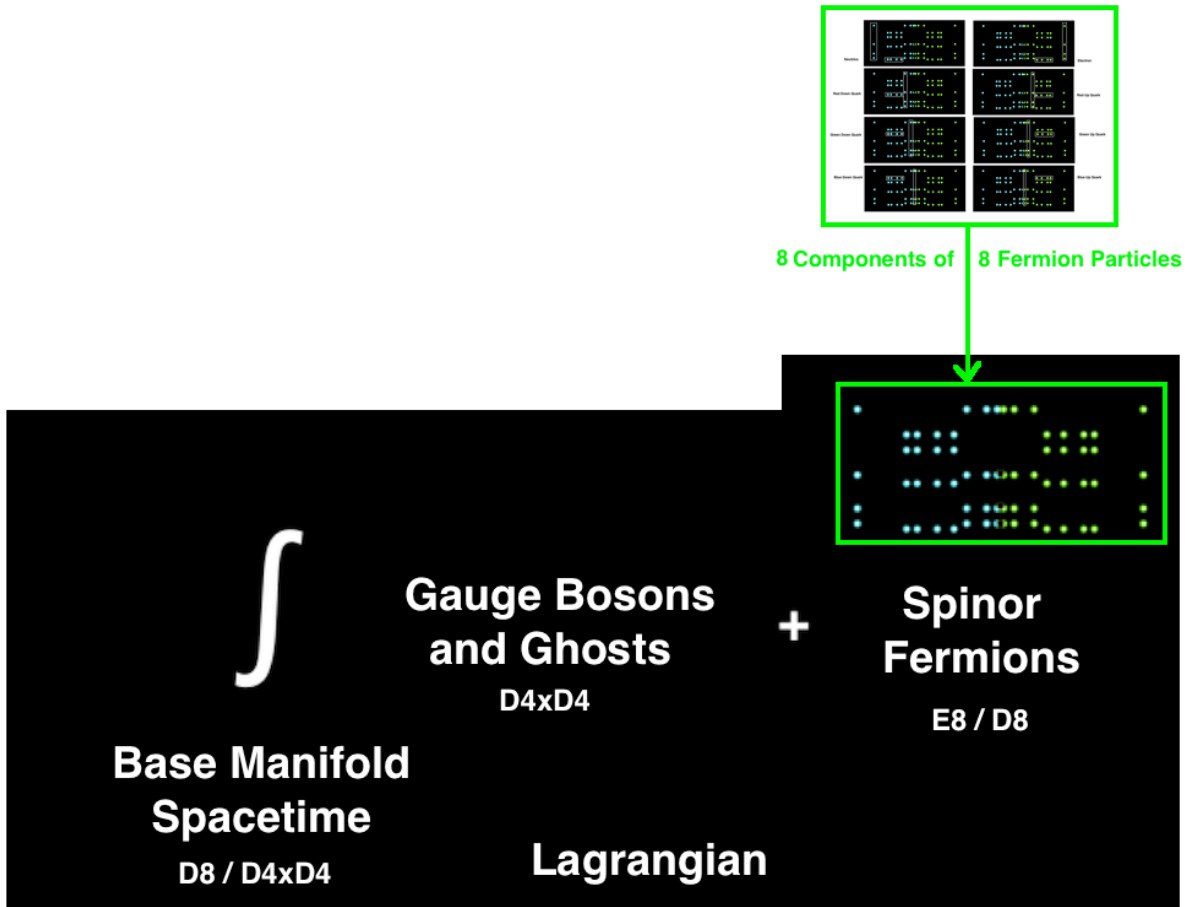

The 64 Red and Magenta Root Vectors represent the First Generation Fermion AntiParticles of E8 / D8

Each of 8 AntiParticles have  
 $8 = 4+4$  M4 x CP2 Kaluza-Klein components  
 so they are represented by  $8 \times 8 = 64$  Root Vectors

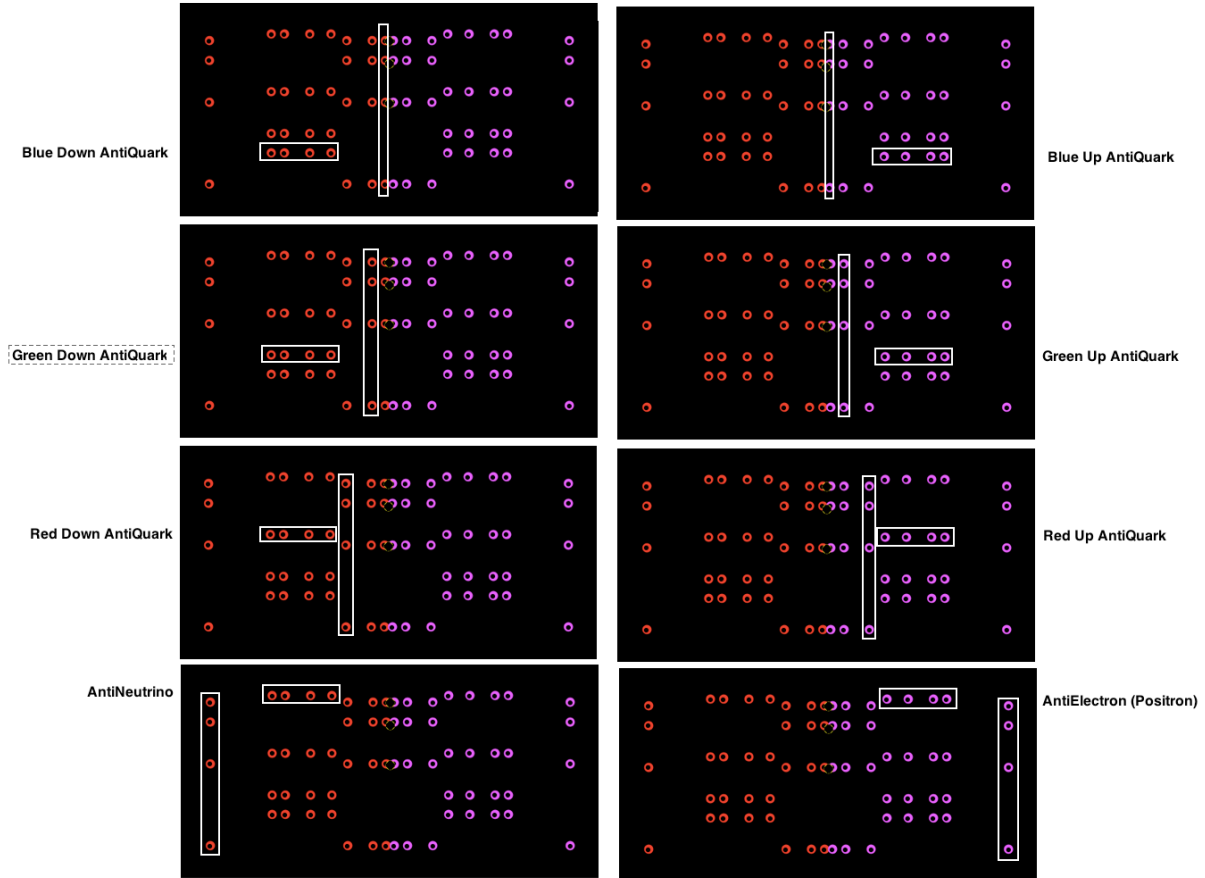

The 8 Fermion AntiParticle Types  $\{\text{Nu}, \text{rDQ}, \text{gDQ}, \text{bDQ}; \text{bUQ}, \text{gUQ}, \text{rUQ}, \text{E}\}$  are represented by  $\text{RP}1 \times \text{S}7$  in the Complex part of the Shilov Boundary S of the 32-real-dim V non-tube type bounded Domain  $(\text{CxO})\text{P}2$  of the EIII Symmetric Space  $\text{E}6 / \text{Spin}(10) \times \text{U}(1)$ .

The bounded Domain is in a subspace of  $\text{J}3(\text{CxO})$  and S is a fiber space with fiber  $\text{RP}1 \times \text{S}7$  (Real part for Particles) and base space  $\text{S}9$  with fibration  $\text{S}1 \rightarrow \text{S}9 \rightarrow \text{CP}4$  that contains a  $\text{RP}1 \times \text{S}7$  (for AntiParticles, in the Complex part) that is isomorphic to the fibre  $\text{RP}1 \times \text{S}7$  (Real part for Particles).

Here is how they fit into the Lagrangian:

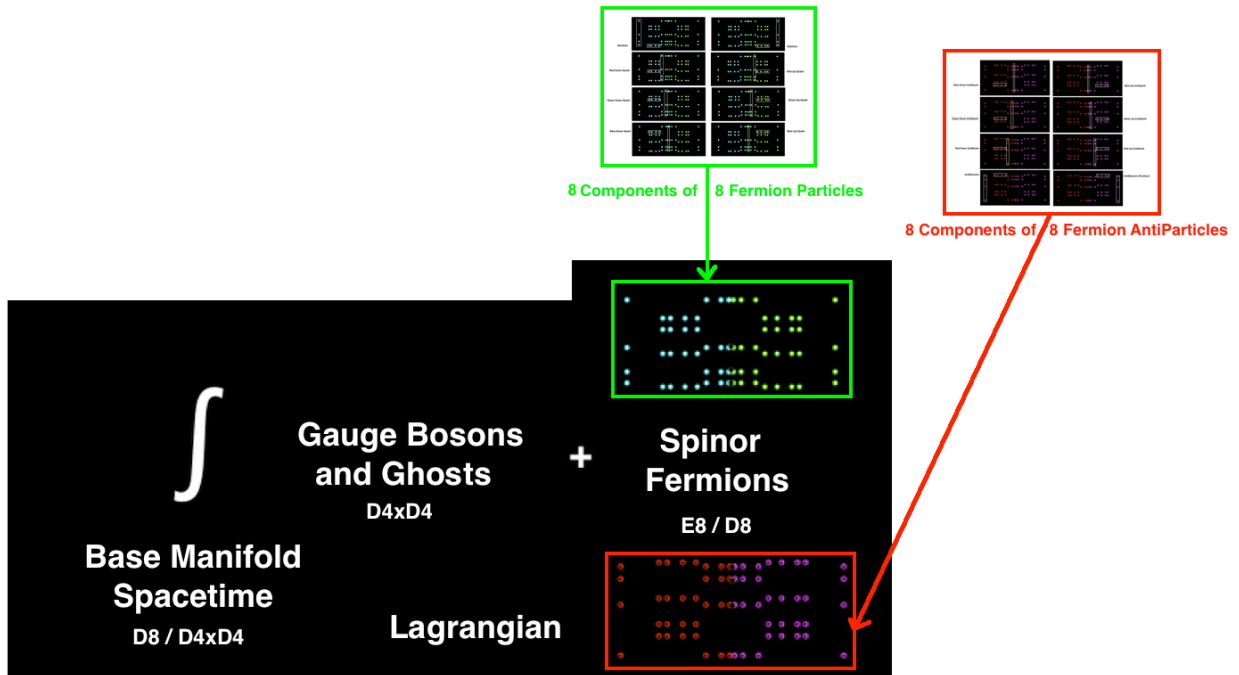

The 64 Blue Root Vectors of D8 / D4xD4 are a Superposition of 8 E8 Spacetime Lattices (7 being Integral Domains) corresponding to the 8 fundamental Fermion Types, each of which has 8-dim M4 x CP2 Kaluza-Klein structure. Effectively, each Fermion Type propagates within its own E8 Lattice within the Superposition forming an 8-dim Generalized Feynman Checkerboard

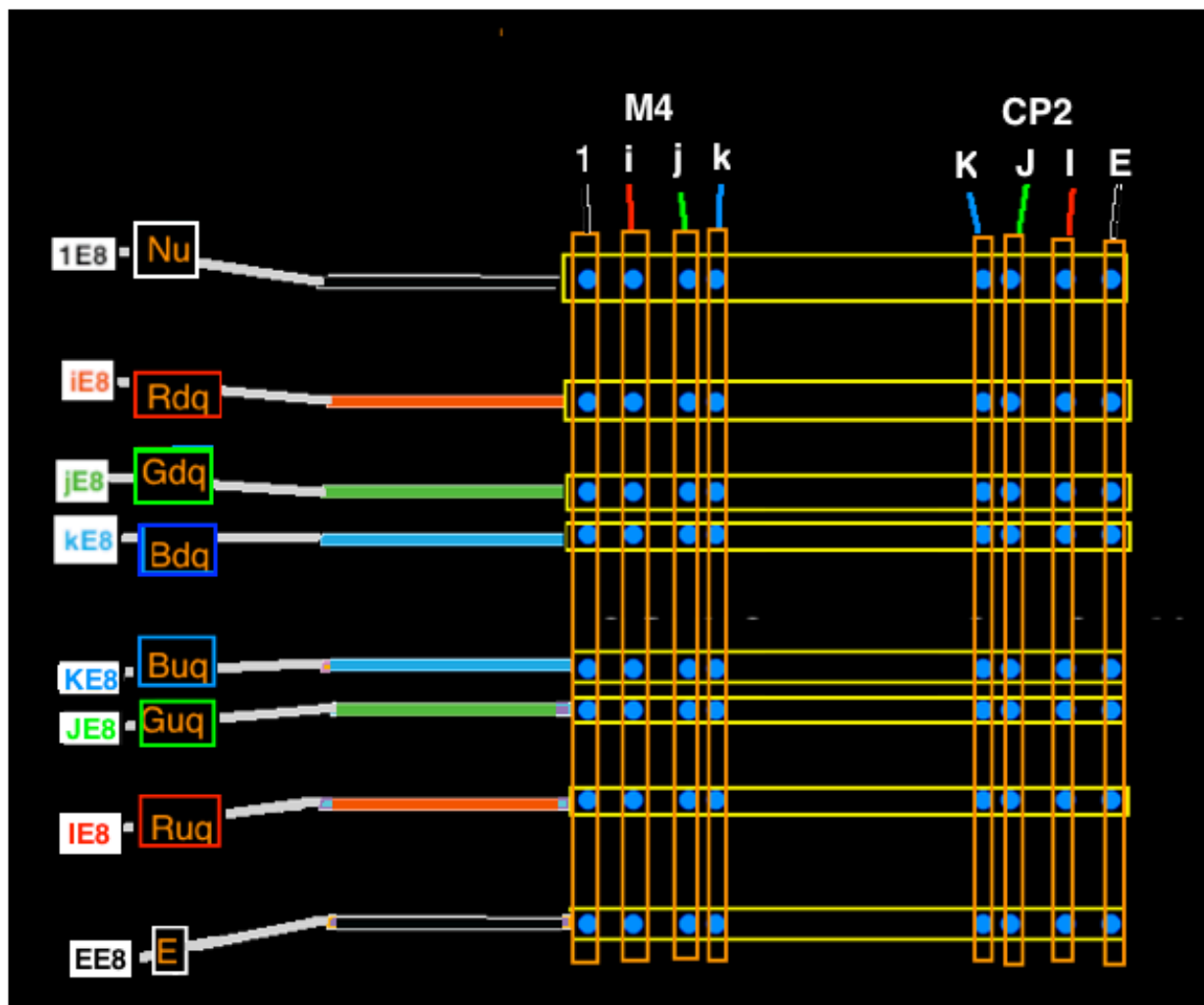

The 8 dimensions of M4xCP2 Spacetime  $\{1, i, j, k, K, J, I, E\}$  are represented by the basis of the 8-real-dim space  $RP^1 \times S^7$  that is the Shilov Boundary of the 16-real-dim  $IV(8,2)$  Bounded Domain (tube type) of the BDI Symmetric Space  $Spin(10) / Spin(8) \times U(1)$

Here is how they fit into the Lagrangian:

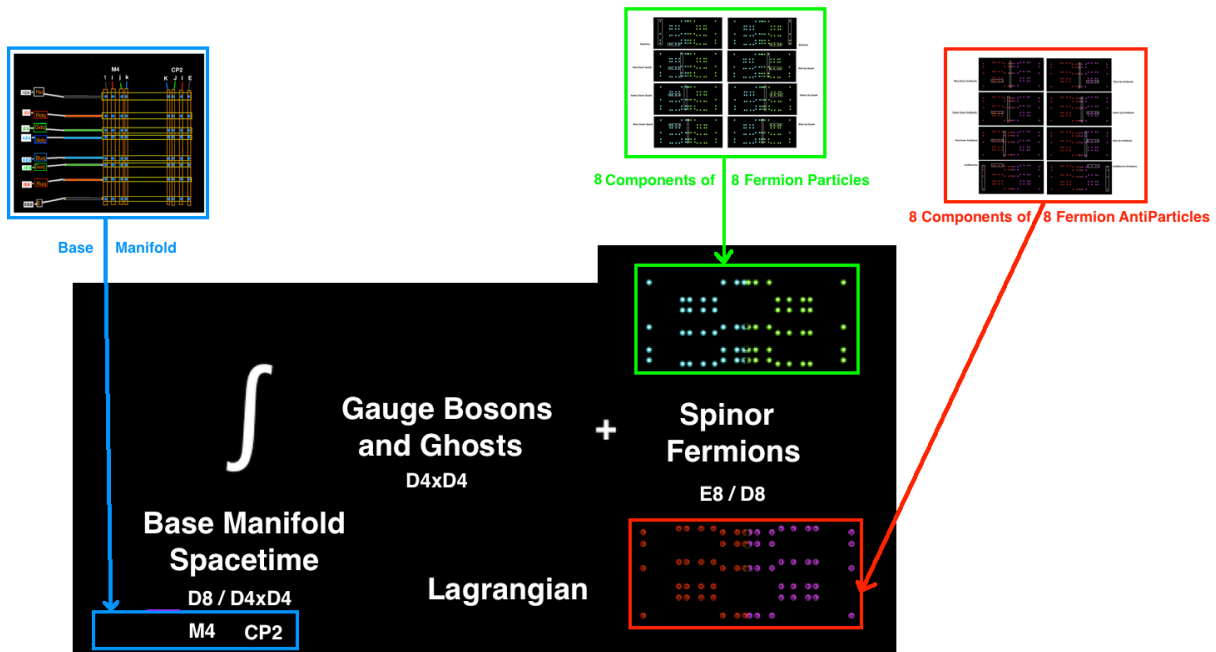

In “Space-Time Code. III” Phys. Rev. D (1972) 2922-2931 David Finkelstein said  
 “... The primitive quantum processes ... of which world lines are made  
 can be thought of as acts of emission or creation,  
 Their duals ... represent acts of absorption or annihilation. ...”.  
 Creation-Annihilation Operators are given by the

Maximal Contraction of E8 = semidirect product A7 x h92  
 where h92 = 92+1+92 Heisenberg algebra and A7 = 63-dim SL(8)

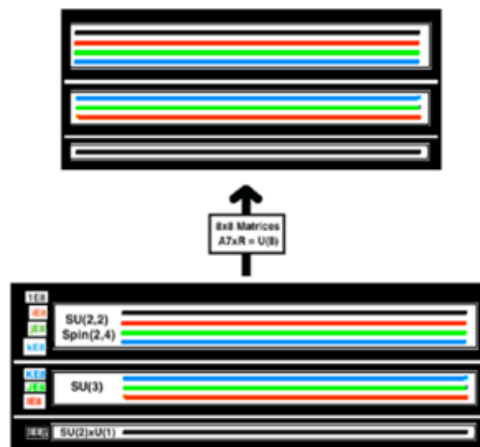

The 8x8 matrices linking one  $\mathbb{V}$  Spacetime Superposition to the next  
 in a World-Line String form 64-dim A7 x R

# Gravity+Dark Energy Gauge Bosons and Ghosts, and U(1) Propagator

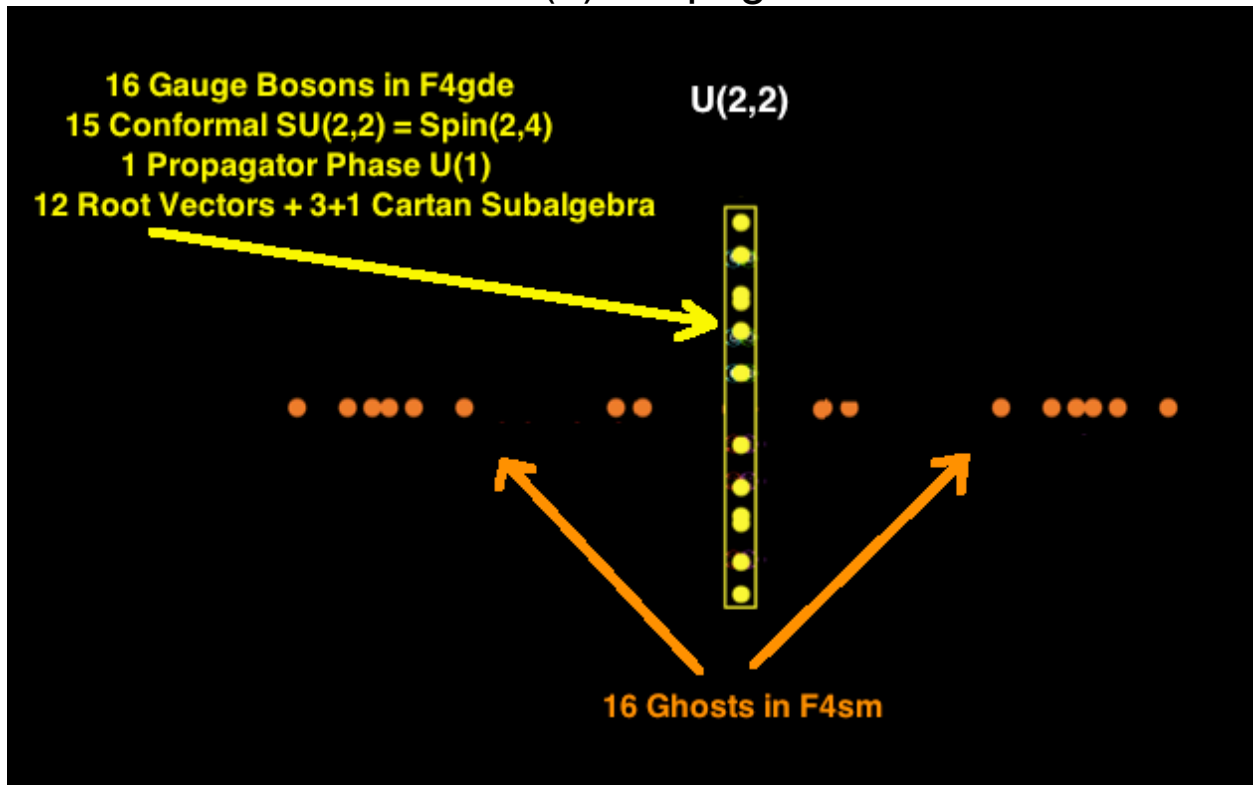

These  $1 + 12 + 3 = 16$  grade-2 Cellular Automata correspond to propagator phase, Conformal Lie Algebra Root Vectors, and Conformal Lie Algebra Cartan Subalgebra

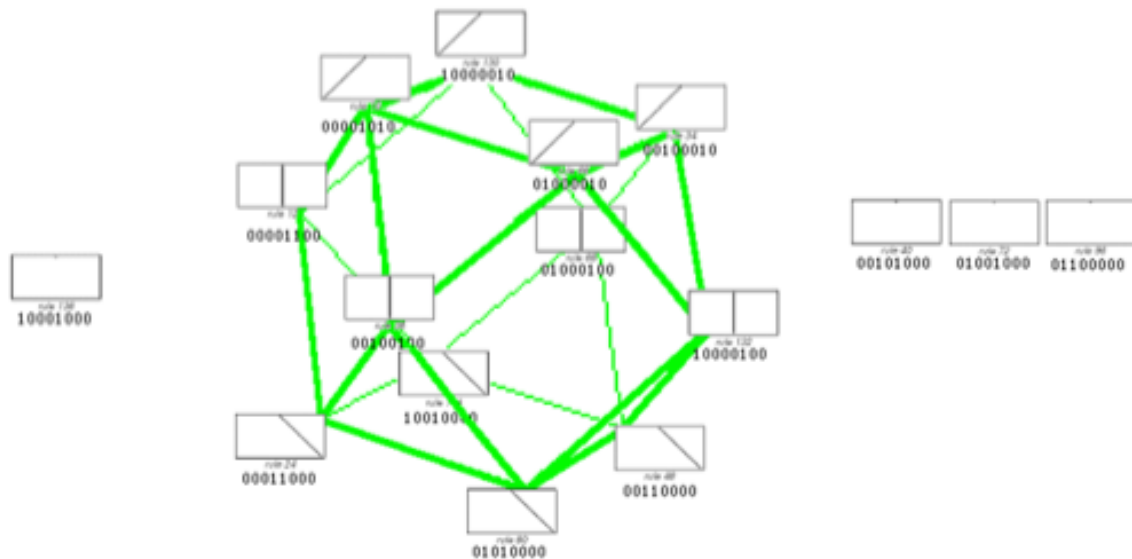

The Conformal Group  $\text{Spin}(2,4) = \text{SU}(2,2)$  gives Gravity+Dark Energy by the MacDowell-Mansouri mechanism.  
 $\text{U}(2,2) = \text{U}(1) \times \text{SU}(2,2)$  also contains the  $\text{U}(1)$  propagator phase

References for Conformal Gravity:

Rabindra Mohapatra in section 14.6 of his book “Unification and Supersymmetry”

R. Aldrovandi and J. G. Peireira in gr-qc/9809061

Irving Ezra Segal in his book “Mathematical Cosmology and Extragalactic Astronomy” (Academic Press 1976)

The ratio

Dark Energy : Dark Matter : Ordinary Matter  
 comes from the structure of  
 the Conformal Group  $SU(2,2) = Spin(2,4)$   
 whose 15 generators are:

10 = 6 Lorentz + 4 Special Conformal for Dark Energy

4 = Translations for Primordial Black Hole Dark Matter

1 = Dilation for Higgs Ordinary Matter

giving a tree-level ratio of

$$10 : 4 : 1 = 0.667 : 0.267 : 0.067$$

Taking Account of differences  
 between Radiation and Matter Eras  
 in the Evolution of Our Universe

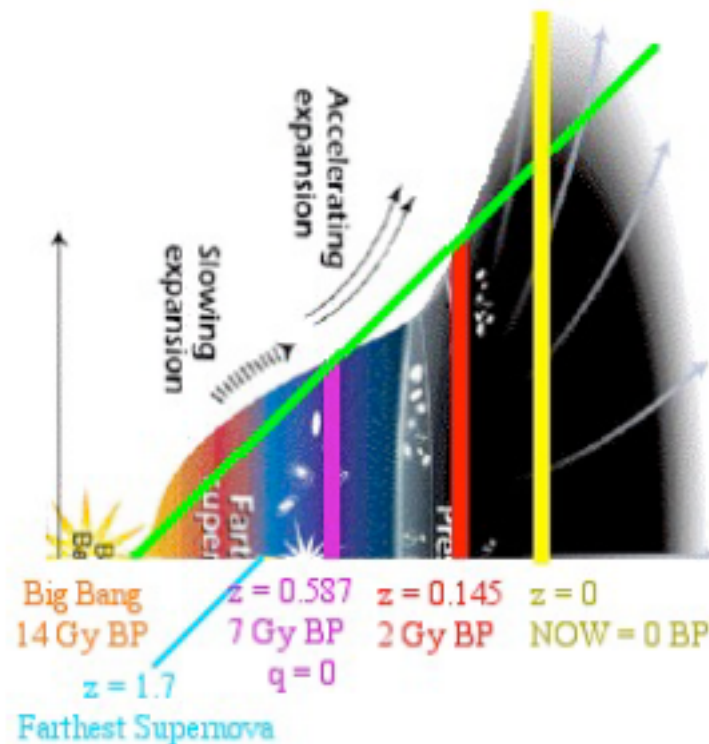

gives Dark Energy : Dark Matter : Ordinary Matter =  
 = 0.75 : 0.21 : 0.04



**Gravity and the Cosmological Constant come from the MacDowell-Mansouri Mechanism and the 15-dimensional Spin(2,4) = SU(2,2) Conformal Group, which is made up of:**

**3 Rotations  
3 Boosts  
4 Translations  
4 Special Conformal transformations  
1 Dilatation**

The **Cosmological Constant / Dark Energy** comes from the **10 Rotation, Boost, and Special Conformal generators** of the Conformal Group Spin(2,4) = SU(2,2), so the fractional part of our Universe of the Cosmological Constant should be **about 10 / 15 = 67% for tree level.**

Black Holes, including **Dark Matter Primordial Black Holes**, are curvature singularities in our 4-dimensional physical spacetime, and since Einstein-Hilbert curvature comes from the **4 Translations** of the 15-dimensional Conformal Group Spin(2,4) = SU(2,2) through the MacDowell-Mansouri Mechanism (in which the generators corresponding to the 3 Rotations and 3 Boosts do not propagate), the fractional part of our Universe of Dark Matter Primordial Black Holes should be **about 4 / 15 = 27% at tree level.**

Since **Ordinary Matter** gets mass from the Higgs mechanism which is related to the **1 Scale Dilatation** of the 15-dimensional Conformal Group Spin(2,4) = SU(2,2), the fractional part of our universe of Ordinary Matter should be **about 1 / 15 = 6% at tree level.**

However,  
**as Our Universe evolves the Dark Energy, Dark Matter, and Ordinary Matter densities evolve at different rates,**  
so that the differences in evolution must be taken into account from the initial End of Inflation to the Present Time.

**Without taking into account any evolutionary changes with time,**  
our Flat Expanding Universe should have roughly:

**67% Cosmological Constant  
27% Dark Matter - possibly primordial stable Planck mass black holes  
6% Ordinary Matter**

As Dennis Marks pointed out to me,  
 since density  $\rho$  is proportional to  $(1+z)^3(1+w)$  for red-shift factor  $z$   
 and a constant equation of state  $w$ :  
 $w = -1$  for  $\Lambda$  and the average overall density of  $\Lambda$  Dark Energy remains constant  
 with time and the expansion of our Universe;  
 and  
 $w = 0$  for nonrelativistic matter so that the overall average density of Ordinary  
 Matter declines as  $1 / R^3$  as our Universe expands;  
 and  
 $w = 0$  for primordial black hole dark matter - stable Planck mass black holes - so  
 that Dark Matter also has density that declines as  $1 / R^3$  as our Universe expands;  
 so that the ratio of their overall average densities must vary with time, or scale  
 factor  $R$  of our Universe, as it expands.  
 Therefore,  
 the above calculated ratio  $0.67 : 0.27 : 0.06$  is valid  
 only for a particular time, or scale factor, of our Universe.

When is that time ? Further, what is the value of the ratio now ?

Since WMAP observes Ordinary Matter at 4% NOW,  
 the time when Ordinary Matter was 6% would be  
 at redshift  $z$  such that  
 $1 / (1+z)^3 = 0.04 / 0.06 = 2/3$  , or  $(1+z)^3 = 1.5$  , or  $1+z = 1.145$  , or  $z = 0.145$ .  
 To translate redshift into time,  
 in billions of years before present, or Gy BP, use this chart

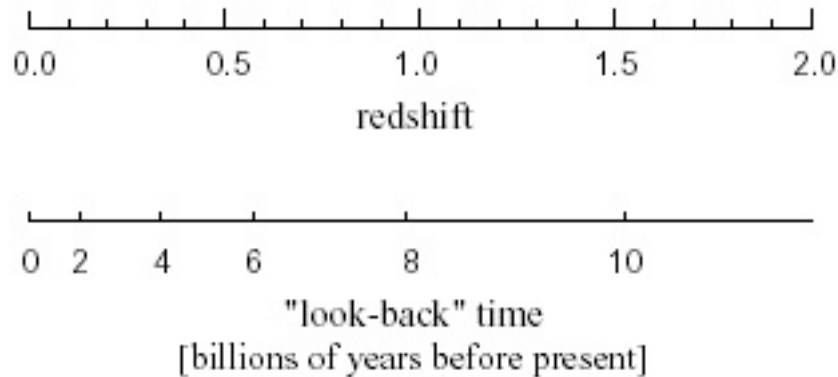

from a [www.supernova.lbl.gov](http://www.supernova.lbl.gov) file SNAPoverview.pdf to see that  
 the time when Ordinary Matter was 6%  
 would have been a bit over 2 billion years ago, or 2 Gy BP.

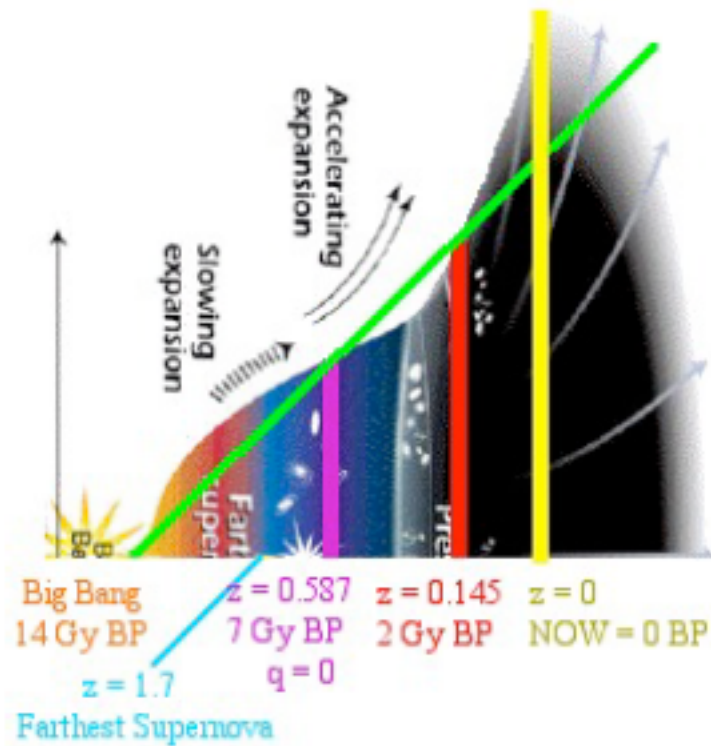

In the diagram, there are four Special Times in the history of our Universe: the Big Bang Beginning of Inflation (about 13.7 Gy BP);

1 - the End of Inflation = Beginning of Decelerating Expansion (beginning of green line also about 13.7 Gy BP);

2 - the End of Deceleration ( $q=0$ ) = Inflection Point = Beginning of Accelerating Expansion (purple vertical line at about  $z = 0.587$  and about 7 Gy BP).

According to a hubblesite web page credited to Ann Feild, the above diagram "... reveals changes in the rate of expansion since the universe's birth 15 billion years ago. The more shallow the curve, the faster the rate of expansion. The curve changes noticeably about 7.5 billion years ago, when objects in the universe began flying apart as a faster rate. ...".

According to a CERN Courier web page: "... Saul Perlmutter, who is head of the Supernova Cosmology Project ... and his team have studied altogether some 80 high red-shift type Ia supernovae. Their results imply that the universe was decelerating for the first half of its existence, and then began accelerating approximately 7 billion years ago. ...".

According to astro-ph/0106051 by Michael S. Turner and Adam G. Riess: "... current supernova data ... favor deceleration at  $z > 0.5$  ... SN 1997ff at  $z = 1.7$  provides direct evidence for an early phase of slowing expansion if the dark energy is a cosmological constant ...".

3 - the Last Intersection of the Accelerating Expansion of our Universe of Linear Expansion (green line) with the Third Intersection (at red vertical line at  $z = 0.145$  and about 2 Gy BP), which is also around the times of the beginning of the Proterozoic Era and Eukaryotic Life, Fe<sub>2</sub>O<sub>3</sub> Hematite ferric iron Red Bed formations, a Snowball Earth, and the start of the Oklo fission reactor. 2 Gy is also about 10 Galactic Years for our Milky Way Galaxy and is on the order of the time for the process of a collision of galaxies.

4 - Now.

Those four Special Times define four Special Epochs:

The Inflation Epoch, beginning with the Big Bang and ending with the End of Inflation. The Inflation Epoch is described by Zizzi Quantum Inflation ending with Self-Decoherence of our Universe ( see gr-qc/0007006 ).

The Decelerating Expansion Epoch, beginning with the Self-Decoherence of our Universe at the End of Inflation. During the Decelerating Expansion Epoch, the Radiation Era is succeeded by the Matter Era, and the Matter Components (Dark and Ordinary) remain more prominent than they would be under the "standard norm" conditions of Linear Expansion.

The Early Accelerating Expansion Epoch, beginning with the End of Deceleration and ending with the Last Intersection of Accelerating Expansion with Linear Expansion. During Accelerating Expansion, the prominence of Matter Components (Dark and Ordinary) declines, reaching the "standard norm" condition of Linear Expansion at the end of the Early Accelerating Expansion Epoch at the Last Intersection with the Line of Linear Expansion.

The Late Accelerating Expansion Epoch, beginning with the Last Intersection of Accelerating Expansion and continuing forever, with New Universe creation happening many times at Many Times. During the Late Accelerating Expansion Epoch, the Cosmological Constant  $\Lambda$  is more prominent than it would be under the "standard norm" conditions of Linear Expansion.

Now happens to be about 2 billion years into the Late Accelerating Expansion Epoch.

What about Dark Energy : Dark Matter : Ordinary Matter now ?

As to how the Dark Energy  $\Lambda$  and Cold Dark Matter terms have evolved during the past 2 Gy, a rough estimate analysis would be:

$\Lambda$  and CDM would be effectively created during expansion in their natural ratio  $67 : 27 = 2.48 = 5 / 2$ , each having proportionate fraction  $5 / 7$  and  $2 / 7$ , respectively; CDM Black Hole decay would be ignored; and pre-existing CDM Black Hole density would decline by the same  $1 / R^3$  factor as Ordinary Matter, from 0.27 to  $0.27 / 1.5 = 0.18$ .

The Ordinary Matter excess  $0.06 - 0.04 = 0.02$  plus the first-order CDM excess  $0.27 - 0.18 = 0.09$  should be summed to get a total first-order excess of  $0.11$ , which in turn should be distributed to the  $\Lambda$  and CDM factors in their natural ratio  $67 : 27$ , producing, for NOW after 2 Gy of expansion:

CDM Black Hole factor =  $0.18 + 0.11 \times 2/7 = 0.18 + 0.03 = 0.21$

for a total calculated **Dark Energy : Dark Matter : Ordinary Matter** ratio for now of

**0.75 : 0.21 : 0.04**

## E8 Real Forms and Evolution of Our Universe

Thanks to Alessio Marrani for correcting my thinking about E8 Real Forms. Also, I apologize for my inconsistent and unconventional use of the terms Spinor and Pinor. Sometimes I use the term Spinor, or  $\text{Spin}(p,q)$ , when I really should use the term Pin, or  $\text{Pin}(p,q)$ . A physical significance of the difference is that Spinors and  $\text{Spin}(n)$  are related to the even subalgebra of the Clifford algebra  $\text{Cl}(p,q)$  ( where  $\text{Cle}(p,q) = \text{Cl}(p,q-1)$  and  $\text{Cle}(p,0) = \text{Cl}(0,p-1)$  ) ) and so do not contain some reflection-related characteristics (such as parity reversal, etc.), while such things are contained in Pin and  $\text{Pin}(p,q)$  because they are related to the full Clifford algebra  $\text{Cl}(p,q)$  including its odd part. A paper by Marcus Berg, Cecile DeWitt-Morette, Shangjr Gwo, and Eric Kramer, math-ph/0012006, discusses Pin and Spin. ... I hope that readers can see what I mean from context, because I have misused the terminology in so many places throughout my materials that I have not had the energy to correct them. However, I do not think that my misuse of math terminology has resulted in wrong physics. That is, the ... E8 ... Physics model is in my opinion physically realistic and valid, even though my description of it may use some incorrect math terminology.

Wikipedia and Einstein Manifolds by Arthur L. Besse say "... There is a unique complex Lie algebra of type E8, corresponding to a complex group of complex dimension 248. ... This is simply connected, has maximal compact subgroup the compact form ... of E8, and has an outer automorphism group of order 2 generated by complex conjugation. As well as the complex Lie group of type E8,

**there are three real forms of the ... E8 ... Lie algebra ...**  
**compact form E8(-248) ...**  
**split form, EVIII (or E8(8)) ...**  
**EIX (or E8(-24)) ...**

The **compact form ... E8(-248) ...** has symmetric space  $E8/SO(16)$  of dimension 128 ... rank 8 with Isotropy representation  $Spin(16)$  ... **Rosenfeld's elliptic projective plane**  $(Ca \times Ca)P^2$  (where  $Ca$  = Cayley Octonions and  $x$  = tensor product) It is simply connected ... has trivial outer automorphism group ... maximal subgroups of  $E8$  ...  $E7 \times SI(2)/(-1,-1)$  and  $E6 \times SU(3)/(Z/3Z)$  ... Symmetric space ...

$E8 / SO(16)$  ...

...  $E8 / E7 \times Sp(1)$  ...

The **split form, EVIII (or E8(8)) ...** has symmetric space  $E8/SO(16)$  of dimension 128 ... rank 8 with Isotropy representation  $Spin(16)$  ... **Rosenfeld's hyperbolic projective plane**  $(Ca \times Ca)P^2$  hyp It has maximal compact subgroup  $Spin(16)/(Z/2Z)$ , fundamental group of order 2 (implying that it has a double cover, which is a simply connected Lie real group but is not algebraic ... ) and has trivial outer automorphism group ... Symmetric space ...

$E8(8) / SO(16)$  ...  $E8(8) / SO(8,8)$  ...  $E8(8) / Sk(8,H) [= E8(8) / SO^*(16) ]...$

...  $E8(8) / E7(7) \times SL(2,R)$  ...  $E8(8) / E8(8) / E7(-5) \times SU(2)$  ...

**EIX (or E8(-24)) ...** has symmetric space  $E8 / E7 \times SU(2)$  of dimension 112 and rank 4 with Isotropy representation  $\wedge^2 E7 \times SU(2)$  that is the Set of  $(H \times Ca)P^2$  hyp 's in " $(Ca \times Ca)P^2$  hyp" (where  $\wedge$  denotes exterior product representation and  $H$  = Quaternions) It has maximal compact subgroup  $E7 \times SU(2)/(-1,-1)$ , fundamental group of order 2 (implying a double cover, which is not algebraic) and has trivial outer automorphism group ... Symmetric Space ...

$E8(-24) / SO(12,4)$  ...  $E8(-24) / Sk(8,H) [= E8(-24) / SO^*(16) ]...$

...  $E8(-24) / E7(-5) \times SU(2)$  [Quaternion-Kahler] ...  $E8(-24) / E7(-25) \times SL(2,R)$  ...".

Since my E8 Physics model is based on the 240 E8 Root Vectors being decomposed into 128 corresponding to D8 Half-Spinors and 112 corresponding to D8 Root Vectors

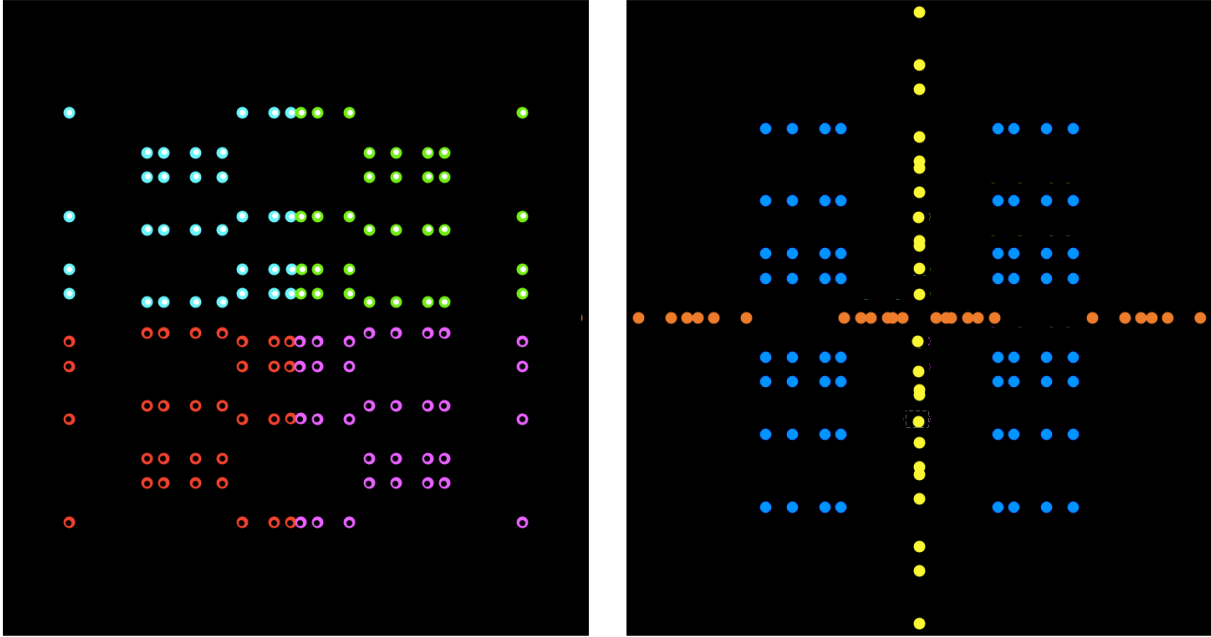

the Real Forms of E8 for my E8 Physics model with Octonionic 8-dim Spacetime prior to Post-Inflation Transition to (4+4)-dim Quaternionic M4 x CP2 Kaluza-Klein are

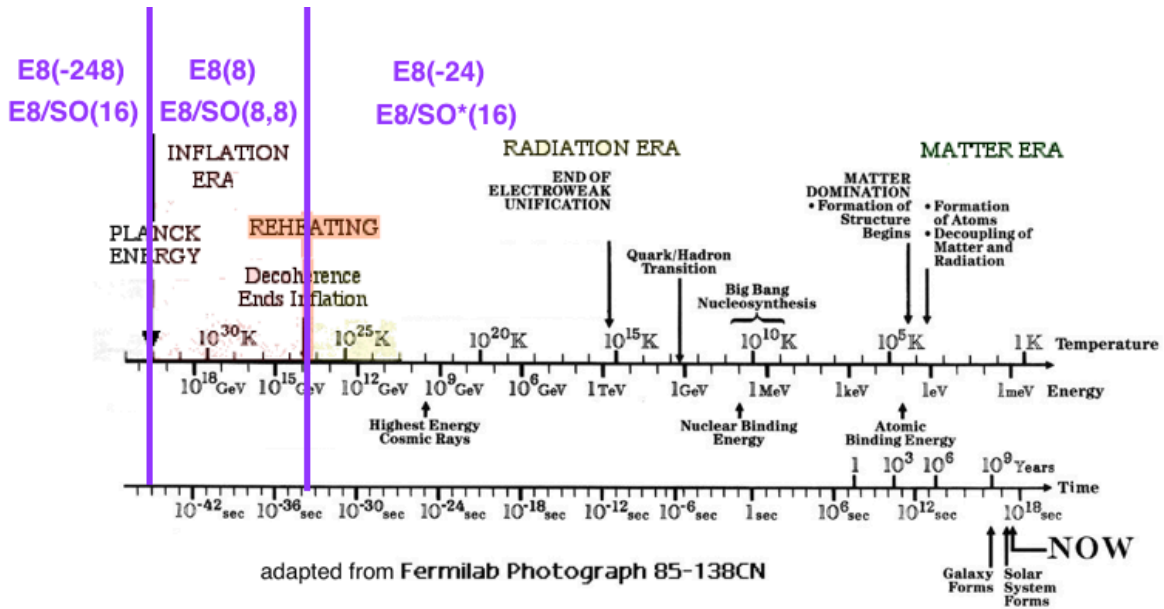

**The First Stage of the Evolution of Our Universe  
was the Initial Planck Cell Big Bang of Compact E8(-248)**

**Our Universe emerged from Our Parent Universe**  
which is only one of many Universes in the huge Family of Universes:

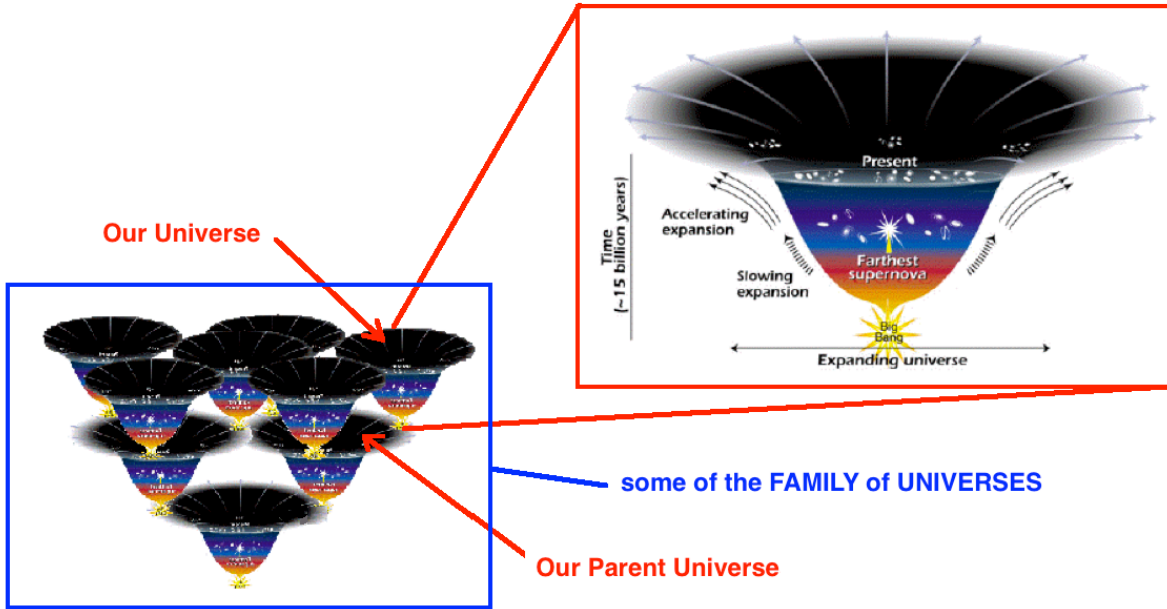

was a compact vacuum fluctuation in a single Planck-scale cell of Our Parent Universe. That Planck cell (like all other Planck cells in any Universe) can be described by taking the quotient of its 24-dimensional subspace modulo the 24-dimensional Leech lattice. Its automorphism group is the largest finite sporadic group, the Monster Group, of order 8080, 17424, 79451, 28758, 86459, 90496, 17107, 57005, 75436, 80000, 00000 =  $2^{46} \cdot 3^{20} \cdot 5^9 \cdot 7^6 \cdot 11^2 \cdot 13^3 \cdot 17 \cdot 19 \cdot 23 \cdot 29 \cdot 31 \cdot 41 \cdot 47 \cdot 59 \cdot 71$  or about  $8 \times 10^{53}$ .

E8 describes the physics in that Big Bang Planck Cell which is Compact so that the Real Form of E8 representing the physics of the Big Bang Planck Cell is E8(-248) with symmetric space E8 / SO(16) of dimension 128 and rank 8 and isotropy representation Spin(16) that is Rosenfeld's Elliptic Projective Plane (OxO)P2 .

**When Our Planck Scale Universe emerged from its Parent Universe  
it was described by SO(16) symmetry of Compact E8(-248).**



## The Second Stage of the Evolution of Our Universe was E8(8) Octonionic Inflation

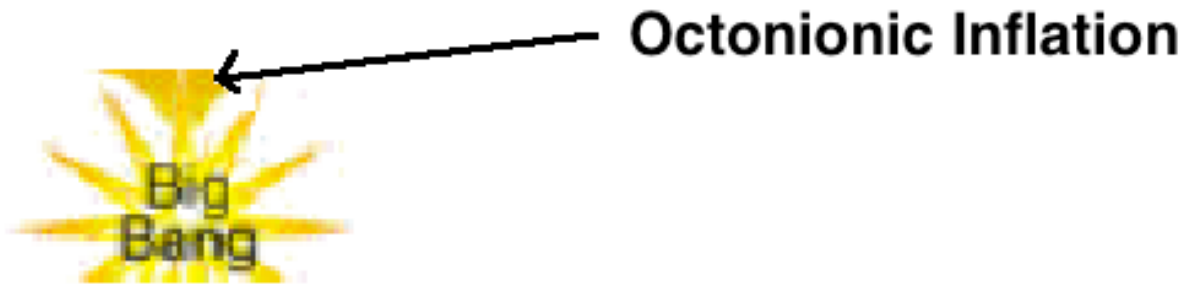

**When Our Universe was expanding rapidly during Octonionic Non-Unitary Inflation it unfolded from Elliptic Compact E8(-248) to Hyperbolic NonCompact SO(8,8) symmetry of NonCompact Split EVIII E8(8).**

**That transition was a shifting of SO(16) symmetry from E8(-248) to E8(8) followed by a Weyl Unitary Trick within E8(8) from SO(16) to SO(8,8).**

As Our Parent Universe expanded to a Cold Thin State Quantum Fluctuations occurred. Most of them just appeared and disappeared as Virtual Fluctuations, but at least one Quantum Fluctuation had enough energy to produce 64 Unfoldings and reach Paola Zizzi's State of Decoherence thus making it a Real Fluctuation that became Our Universe.

As Our Universe expands to a Cold Thin State, it will probably give birth to Our Child, GrandChild, etc, Universes.

Unlike "the inflationary multiverse" described by Andrei Linde in arXiv 1402.0526 as "a scientific justification of the anthropic principle", in the Cl(16) model ALL Universes (Ours, Ancestors, Descendants) have the SAME Physics Structure as E8 Physics ( viXra 1312.0036 and 1310.0182 )

In the Cl(16) model, Fr3(O) structure gives 26D World-Line=String Theory and Cl(1,25) with underlying E8 Lagrangian structure, and our SpaceTime remains Octonionic 8-dimensional throughout inflation.

Stephen L. Adler in his book Quaternionic Quantum Mechanics and Quantum Fields (1995) said at pages 50-52, 561: "... If the multiplication is associative, as in the complex and quaternionic cases, we can remove parentheses in ... Schroedinger equation dynamics ... to conclude that ... the inner product  $\langle f(t) | g(t) \rangle$  ... is invariant ... this proof fails in the octonionic case, and hence one cannot follow the standard procedure to get a unitary dynamics. ...[so there is a]... **failure of unitarity in octonionic quantum mechanics ...**".

**Creation-Annihilation Operators are the 64-dim grade-0 part  
of the E8 Maximal Contraction generalized Heisenberg Algebra**  
 $\hbar^2 \times A_7 = 28 + 64 + ((SL(8,R)+1) + 64 + 28$

The central grade-0 part  $A_7 \times R$  of the Heisenberg Algebra gives  
 Unimodular  $SL(8,R)$  Gravity

which describes a checkerboard of 8-dim SpaceTime HyperVolume Elements and,  
 with respect to  $Cl(16) = Cl(8) \times Cl(8)$ ,  
 is the tensor product of the two 8v vector spaces of the two  $Cl(8)$  factors of  $Cl(16)$ .

Bradonjic and Stachel in arXiv 1110.2159 said: "... in ... Unimodular relativity ... the metric tensor ... break[s up] ... into the conformal structure represented by a conformal metric ... with  $\det = -1$  and a four-volume element ... at each point of space-time ... [that]... may be the remnant, in the ... continuum limit, of a more fundamental discrete quantum structure of space-time itself ...".

Conformal  $Spin(2,4) = SU(2,2)$  Gravity and Unimodular  $SL(4,R) = Spin(3,3)$  Gravity seem to be effectively equivalent. Padilla and Saltas in arXiv 1409.3573 said:  
 "... classical unimodular gravity and classical GR are the same thing, and they can be extended into the UV such that the equivalence is maintained. ...  
 Classical unimodular gravity = classical GR. ...  
 Quantum unimodular gravity = quantum GR provided we make certain assumptions about how we extend into the UV. ...".

Frampton, Ng, and Van Dam in J. Math. Phys. 33 (1992) 3881-3882 said:  
 "... Because of the existence of topologically nontrivial solutions, instantons, of the classical field equations associated with quantum chromodynamics (QCD), the quantized theory contains a dimensionless parameter  $\theta$  ( $0 < \theta < 2\pi$ ) not explicit in the classical lagrangian. Since  $\theta$  multiplies an expression odd in CP, **QCD predicts violation of ... CP ... symmetry unless the phase  $\theta$  takes one of the special values ...  $0 \pmod{\pi}$  ... this fine tuning is the strong CP problem ... the quantum dynamics of ... unimodular gravity ... may lead to the relaxation of  $\theta$  to  $\theta = 0 \pmod{\pi}$  without the need ... for a new particle ... such as the axion ...".**

**The NonAssociativity and Non-Unitarity of Octonions  
accounts for particle creation without the need for a conventional inflaton field.**

E8 Physics has Representation space for 8 Fermion Particles + 8 Fermion Antiparticles on the original Cl(1,25) E8 Local Lagrangian Region



where a Fermion Representation slot \_ of the  $8+8 = 16$  slots can be filled

by Real Fermion Particles ■ or Real Fermion Antiparticles ■

IF the Quantum Fluctuation( QF ) has enough Energy to produce them as Real and

IF the Cl(1,25) E8 Local Lagrangian Region has an Effective Path from its QF Energy to that Particular slot.

Let  $Cl(16) = Cl(8) \times Cl(8)$  contained in Cl(1,25) where the first Cl(8) contains the D4 of Conformal Gravity with actions on M4 physical spacetime whose CPT symmetry determines the property matter - antimatter.

Consider, following basic ideas of Geoffrey Dixon related to his characterization of 64-dimensional spinor spaces as  $C \times H \times O$  (  $C = \text{complex}$ ,  $H = \text{quaternion}$ ,  $O = \text{octonion}$  ),  
64-dim  $64s^{++} = 8s^{+} \times 8s^{+}$  of  $Cl(8) \times Cl(8) = Cl(16)$

and

64-dim  $64s^{+-} = 8s^{+} \times 8s^{-}$  of  $Cl(8) \times Cl(8) = Cl(16)$

so that

$64s^{++} + 64s^{+-} = 128s^{+}$  are +half-spinors of Cl(16) which is in E8

Then Cl(16) contains

128-dim +half-spinor space  $64s^{++} + 64s^{+-}$  of Cl(16) in E8 = Fermion Generation

and

128-dim -half-spinor space  $64s^{-+} + 64s^{--}$  of Cl(16) not in E8 = Fermion AntiGeneration

Since E8 contains only the 128 +half-spinors and none of the 128 -half-spinors of Cl(16) and

since, due to their +half-spinor property with respect to the first Cl(8), the  $128s^{+} = 64s^{++} + 64s^{+-}$  have only Effective Paths of QF Energy that go to the Fermion Particle slots that are also of type + that is, to the 8 Fermion Particle Representation slots



Next, consider **the first Unfolding step of Octonionic Inflation**. It is based on all  $16 = 8$  Fermion Particle slots + 8 Fermion Antiparticle Representation slots whether or not they have been filled by QF Energy. 7 of the 8 Fermion Particle slots correspond to the 7 Imaginary Octonions and therefore to the 7 Independent E8 Integral Domain Lattices and therefore to 7 New  $CI(1,25)$  E8 Local Lagrangian Regions. The 8th Fermion Particle slot corresponds to the 1 Real Octonion and therefore to the 8th E8 Integral Domain Lattice ( not independent - see Kirmse's mistake ) and therefore to the 8th New  $CI(1,25)$  E8 Local Lagrangian Region. Similarly, the 8 Fermion Antiparticle slots Unfold into 8 more New New  $CI(1,25)$  E8 Local Lagrangian Regions, so that one Unfolding Step is a 16-fold multiplication of  $CI(1,25)$  E8 Local Lagrangian Regions:

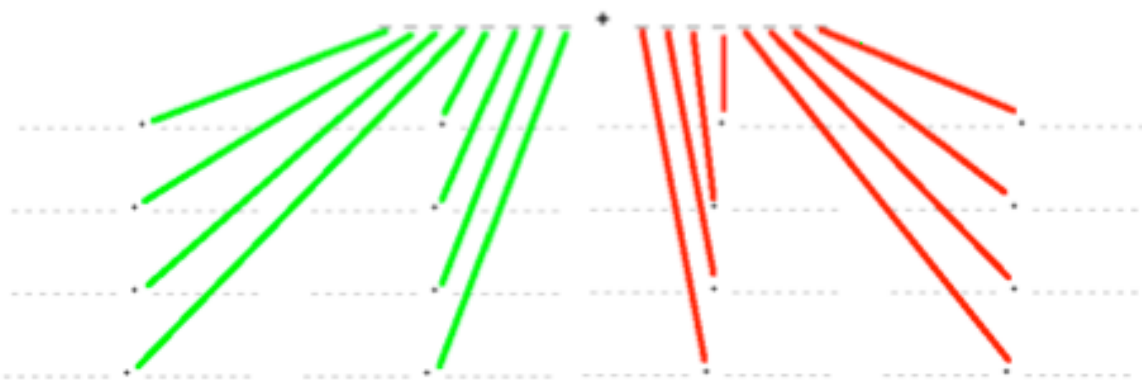

If the QF Energy is sufficient, the Fermion Particle content after the first Unfolding is

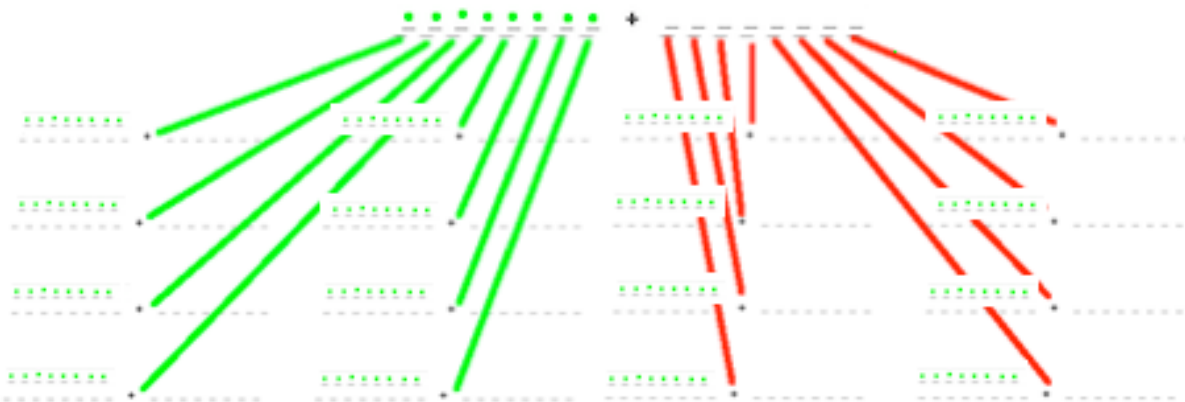

so it is clear that **the Octonionic Inflation Unfolding Process creates Fermion Particles with no Antiparticles, thus explaining the dominance of Matter over AntiMatter in Our Universe.**

Each Unfolding has duration of the Planck Time  $T_{\text{planck}}$  and none of the components of the Unfolding Process Components are simultaneous, so that **the total duration of N Unfoldings is  $2^N T_{\text{planck}}$ .**

**Paola Zizzi** in gr-qc/0007006 said: "... during inflation, the universe can be described as a superposed state of quantum ... [ qubits ].

the self-reduction of the superposed quantum state is ... reached at the end of inflation ...[at]... **the decoherence time ... [ Tdecoh = 10<sup>9</sup> Tplanck = 10<sup>(-34)</sup> sec ] ... and corresponds to a superposed state of ... [ 10<sup>19</sup> = 2<sup>64</sup> qubits ]. ...".**

### **Why decoherence at 64 Unfoldings = 2<sup>64</sup> qubits ?**

2<sup>64</sup> qubits corresponds to the Clifford algebra Cl(64) = Cl(8x8).

By the periodicity-8 theorem of Real Clifford algebras, Cl(64) is the smallest Real Clifford algebra for which we can reflexively identify each component Cl(8) with a vector in the Cl(8) vector space. This reflexive identification/reduction causes our universe to decohere at N = 2<sup>64</sup> = 10<sup>19</sup>

which is roughly the number of Quantum Consciousness Tubulins in the Human Brain.

The Real Clifford Algebra Cl(8) is the basic building block of Real Clifford Algebras due to 8-Periodicity whereby Cl(8N) = Cl(8) x ... (N times tensor product) ... x Cl(8)

An Octonionic basis for the Cl(8) 8-dim vector space is {1, i, j, k, E, I, J, K}

NonAssociativity, NonUnitarity, and Reflexivity of Octonions is exemplified by the 1-1 correspondence between Octonion Basis Elements and E8 Integral Domains

$$\begin{aligned} 1 &\Leftrightarrow 0E8 & i &\Leftrightarrow 1E8 & j &\Leftrightarrow 2E8 & k &\Leftrightarrow 3E8 \\ E &\Leftrightarrow 4E8 & I &\Leftrightarrow 5E8 & J &\Leftrightarrow 6E8 & K &\Leftrightarrow 7E8 \end{aligned}$$

where 1E8, 2E8, 3E8, 4E8, 5E8, 6E8, 7E8 are 7 independent Integral Domain E8 Lattices and 0E8 is an 8th E8 Lattice (Kirmse's mistake) not closed as an Integral Domain.

Using that correspondence expands the basis {1, i, j, k, E, I, J, K} to

$$\{0E8, 1E8, 2E8, 3E8, 4E8, 5E8, 6E8, 7E8\}$$

Each of the E8 Lattices has 240 nearest neighbor vectors so the total dimension of the Expanded Space is 240 x 240 x 240 x 240 x 240 x 240 x 240 x 240

Everything in the Expanded Space comes directly from the original Cl(8) 8-dim space so all Quantum States in the Expanded Space can be held in Coherent Superposition. However,

if further expansion is attempted, there is no direct connection to original Cl(8) space and any Quantum Superposition undergoes Decoherence.

If each 240 is embedded reflexively into the 256 elements of Cl(8) the total dimension is

$$\begin{aligned} &256 \times 256 \times 256 \times 256 \times 256 \times 256 \times 256 \times 256 = 256^8 = 2^{(8 \times 8)} = 2^{64} = \\ &= Cl(8) \times Cl(8) \times Cl(8) \times Cl(8) \times Cl(8) \times Cl(8) \times Cl(8) \times Cl(8) = Cl(8 \times 8) = Cl(64) \end{aligned}$$

so the largest Clifford Algebra that can maintain Coherent Superposition is Cl(64)

which is why Zizzi Quantum Inflation ends at the Cl(64) level.

**At the end of 64 Unfoldings, Non-Unitary Octonionic Inflation ended having produced about (1/2) 16<sup>64</sup> = (1/2) (2<sup>4</sup>)<sup>64</sup> = 2<sup>255</sup> = 6 x 10<sup>76</sup> Fermion Particles**

**The End of Inflation time was at about 10<sup>(-34)</sup> sec = 2<sup>64</sup> Tplanck  
and**

**the size of our Universe was then about 10<sup>(-24)</sup> cm**

**which is about the size of a Fermion Schwinger Source Kerr-Newman Cloud.**

**After the End of Inflation E8 Physics** has a transition  
 from 8-dim Octonionic Spacetime to  
**(4+4)-dim Quaternionic Kaluza-Klein Spacetime M4 x CP2**  
 where M4 is 4-dim physical Minkowski Spacetime  
 and CP2 = SU(3) / SU(2) x U(1) Internal Symmetry Space  
 so that

the **Symmetric Space of E8 Physics** goes from Octonionic SO(16) or SO(8,8) to  
**Quaternionic Sk(8,H) = SO\*(16)**  
 of  
**EIX E8(-24) with E8(-24) / Sk(8,H) = E8(-24) / SO\*(16)**

**When Inflation ended 8-dim Octonionic Spacetime was broken into  
 (4+4)-dim Unitary Quaternionic M4 x CP2 Kaluza-Klein Spacetime  
 with SO\*(16) symmetry of EIX E8(-24).**

**That transition was a Weyl Unitary Trick within E8(8) from SO(8,8) to SO\*(16)  
 followed by a shifting of SO\*(16) symmetry from E8(8) to E8(-24).**

Robert Gilmore

in his 1974 book Lie Groups, Lie Algebras, and Some of Their Applications, says “...

**WEYL UNITARY TRICK.** A real space with a signature  $(N_+, N_-)$   
 can be converted to a space with metric  $(N_+ + N_-, 0)$  by choosing a new set  
 of bases

$$(\mathbf{e}_1, \mathbf{e}_2, \dots, \mathbf{e}_{N_+}, \mathbf{e}_{N_++1}, \dots, \mathbf{e}_{N_++N_-}) \rightarrow (\mathbf{e}_1, \mathbf{e}_2, \dots, \mathbf{e}_{N_+}, i\mathbf{e}_{N_++1}, \dots, i\mathbf{e}_{N_++N_-}) \quad (3.19)$$

Of course, we have to go outside the field of real numbers to perform this transformation. For example, the space-time of special relativity has metric  $(+ + + -)$  with respect to the real contravariant bases  $(x, y, z, ct)$  but metric  $(+ + + +)$  with respect to  $(x, y, z, ict)$ . This transformation from a mixed to a positive metric is called the **Weyl unitary trick**. It was apparently first used by Minkowski.

? (1970- ) .

It now

seems possible that Lie group theory, together with differential geometry, harmonic analysis, and some devious arguments, might be able to predict some of Nature’s dimensionless numbers  $(\alpha, m_p/m_e, m_\mu/m_e, G^2/hc, \dots)$ . In retrospect, it seems clear that the application of group theory to physical problems represents the dividing line between kinematics and dynamics. The group theory gives the overall structure of the spectrum; the dynamics serves to define only the scale. We are looking forward to the day when Lie groups can be pushed to give also the dynamics, or scale.

...”

# Pioneer Anomaly and Uranus Rotation Axis

## Conformal Gravity + Dark Energy and Pioneer Anomaly

After the Inflation Era and our Universe began its current phase of expansion, some regions of our Universe become Gravitationally Bound Domains (such as, for example, Galaxies) in which the 4 Conformal GraviPhoton generators are frozen out, forming domains within our Universe like IceBergs in an Ocean of Water. On the scale of our Earth-Sun Solar System, the region of our Earth, where we do our local experiments, is in a Gravitationally Bound Domain.

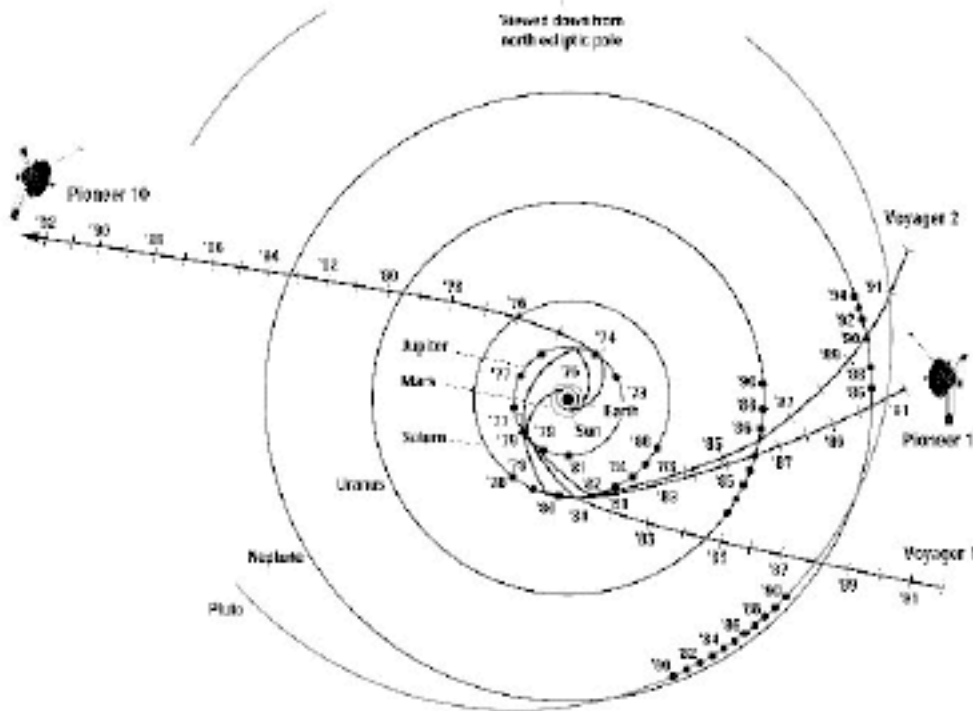

Pioneer spacecraft are not bound to our Solar System and are experiments beyond the Gravitationally Bound Domain of our Earth-Sun Solar System.

In their Study of the anomalous acceleration of Pioneer 10 and 11 gr-qc/0104064 John D. Anderson, Philip A. Laing, Eunice L. Lau, Anthony S. Liu, Michael Martin Nieto, and Slava G. Turyshev say: "... The latest successful precession maneuver to point ...[Pioneer 10]... to Earth was accomplished on 11 February 2000, when Pioneer 10 was at a distance from the Sun of 75 AU. [The distance from the Earth was [about] 76 AU with a corresponding round-trip light time of about 21 hour.] ... The next attempt at a maneuver, on 8 July 2000, was unsuccessful ... conditions will again be favorable for an attempt around July, 2001. ... At a now nearly constant velocity relative to the Sun of 12.24 km/s, Pioneer 10 will continue its motion into interstellar space, heading generally for the red star Aldebaran ... about 68 light years away ... it should take Pioneer 10 over 2 million years to reach its neighborhood....

[ the above image is ] Ecliptic pole view of Pioneer 10, Pioneer 11, and Voyager trajectories. Digital artwork by T. Esposito. NASA ARC Image # AC97-0036-3.  
 ... on 1 October 1990 ... Pioneer 11 ... was [about] 30 AU away from the Sun ...  
 The last communication from Pioneer 11 was received in November 1995, when the spacecraft was at distance of [about] 40 AU from the Sun. ... Pioneer 11 should pass close to the nearest star in the constellation Aquila in about 4 million years ...  
 ... Calculations of the motion of a spacecraft are made on the basis of the range time-delay and/or the Doppler shift in the signals. This type of data was used to determine the positions, the velocities, and the magnitudes of the orientation maneuvers for the Pioneer, Galileo, and Ulysses spacecraft considered in this study. ... The Pioneer spacecraft only have two- and three-way S-band Doppler. ... analyses of radio Doppler ... data ... indicated that an apparent anomalous acceleration is acting on Pioneer 10 and 11 ... The data implied an anomalous, constant acceleration with a magnitude  $a_P = 8 \times 10^{-8} \text{ cm/cm/s}^2$ , directed towards the Sun ...  
 ... the size of the anomalous acceleration is of the order  $c H$ , where  $H$  is the Hubble constant ...  
 ... Without using the apparent acceleration, CHASMP shows a steady frequency drift of about  $-6 \times 10^{-9} \text{ Hz / s}$ , or 1.5 Hz over 8 years (one-way only). ... This equates to a clock acceleration,  $-a_t$ , of  $-2.8 \times 10^{-18} \text{ s / s}^2$ . The identity with the apparent Pioneer acceleration is  $a_P = a_t c$ . ...  
 ... Having noted the relationships

$$a_P = c a_t$$

and that of ...

$$a_H = c H \rightarrow 8 \times 10^{-8} \text{ cm / s}^2$$

if  $H = 82 \text{ km / s / Mpc}$  ...

we were motivated to try to think of any ... "time" distortions that might ... fit the CHASMP Pioneer results ... In other words ...

Is there any evidence that some kind of "time acceleration" is being seen?

... In particular we considered ... Quadratic Time Augmentation. This model adds a quadratic-in-time augmentation to the TAI-ET ( International Atomic Time - Ephemeris Time ) time transformation, as follows

$$ET \rightarrow ET + (1/2) a_{ET} ET^2$$

The model fits Doppler fairly well

...

There was one [other] model of the ...[time acceleration]... type that was especially fascinating. This model adds a quadratic in time term to the light time as seen by the DSN station:

$$\begin{aligned} \Delta TAI &= TAI_{received} - TAI_{sent} \rightarrow \\ &\rightarrow \Delta TAI + (1/2) a_{quad} (TAI_{received}^2 - TAI_{sent}^2) \end{aligned}$$

It mimics a line of sight acceleration of the spacecraft, and could be thought of as an expanding space model.

Note that  $a_{quad}$  affects only the data. This is in contrast to the  $a_t$  ... that affects both the data and the trajectory. ... This model fit both Doppler and range very well. Pioneers 10 and 11 ... the numerical relationship between the Hubble constant and  $a_P$  ... remains an interesting conjecture. ...".



In his book "Mathematical Cosmology and Extragalactic Astronomy" (Academic Press 1976) (pages 61-62 and 72), Irving Ezra Segal says:

"... Temporal evolution in ... Minkowski space ... is

$$H \rightarrow H + s l$$

... unispace temporal evolution ... is ...

$$H \rightarrow (H + 2 \tan(a/2)) / (1 - (1/2) H \tan(a/2)) = H + a l + (1/4) a H^2 + O(s^2)$$

..."

Therefore,

the Pioneer Doppler anomalous acceleration is an experimental observation of a system that is not gravitationally bound in the Earth-Sun Solar System, and its results are consistent with Segal's Conformal Theory.

My view can be summarized as a 2-phase model based on Segal's work which has two phases with different metrics:

a metric for outside the inner solar system, a dark energy phase in which gravity is described in which all 15 generators of the conformal group are effective, some of which are related to the dark energy by which our universe expands;

and

a metric for where we are, in regions dominated by ordinary matter, in which the 4 special conformal and 1 dilation degrees of freedom of the conformal group are suppressed and the remaining 10 generators (antideSitter or Poincare, etc) are effective, thus describing ordinary matter phenomena.

## Transition at Orbit of Uranus:

It may be that the observation of the Pioneer phase transition at Uranus from ordinary to anomalous acceleration is an experimental result that gives us a first look at dark energy / dark matter phenomena that could lead to energy sources that could be even more important than nuclear energy.

In gr-qc/0104064 Anderson et al say:

"... Beginning in 1980 ... at a distance of 20 astronomical units (AU) from the Sun ... we found that the largest systematic error in the acceleration residuals was a constant bias,  $a_P$ , directed toward the Sun. Such anomalous data have been continuously received ever since. ...",

so that the transition from inner solar system Minkowski acceleration to outer Segal Conformal acceleration occurs at about 20 AU, which is about the radius of the orbit of Uranus. That phase transition may account for the unique rotational axis of Uranus,

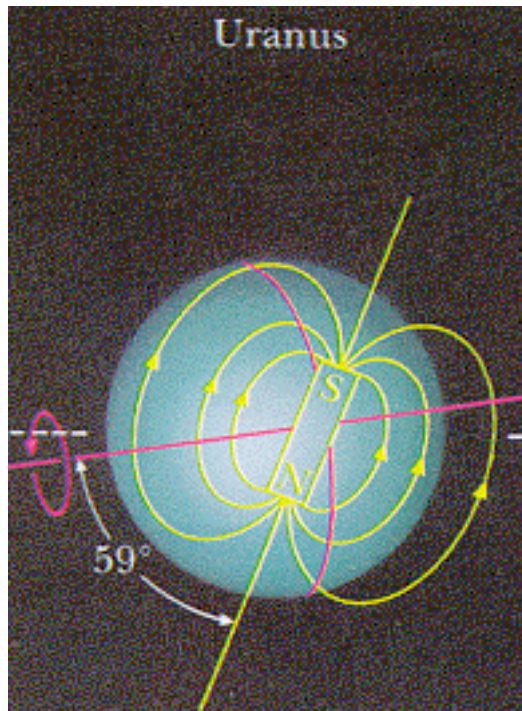

which lies almost in its orbital plane.

The most stable state of Uranus may be with its rotational axis pointed toward the Sun, so that the Solar hemisphere would be entirely in the inner solar system Minkowski acceleration phase and the anti-Solar hemisphere would be in entirely in the outer Segal Conformal acceleration phase.

Then the rotation of Uranus would not take any material from one phase to the other, and there would be no drag on the rotation due to material going from phase to phase.

Of course, as Uranus orbits the Sun, it will only be in that most stable configuration twice in each orbit, but an orbit in the ecliptic containing that most stable configuration twice (such as its present orbit) would be in the set of the most stable ground states, although such an effect would be very small now. However, such an effect may have been more significant on the large gas/dust cloud that was condensing into Uranus and therefore it may have caused Uranus to form initially with its rotational axis pointed toward the Sun.

In the pre-Uranus gas/dust cloud, any component of rotation that carried material from one phase to another would be suppressed by the drag of undergoing phase transition, so that, after Uranus condensed out of the gas/dust cloud, the only remaining component of Uranus rotation would be on an axis pointing close to the Sun, which is what we now observe.

In the pre-Uranus gas/dust cloud, any component of rotation that carried material from one phase to another would be suppressed by the drag of undergoing phase transition, so that, after Uranus condensed out of the gas/dust cloud, the only remaining component of Uranus rotation would be on an axis pointing close to the Sun, which is what we now observe.

Much of the perpendicular (to Uranus orbital plane) angular momentum from the original gas/dust cloud may have been transferred (via particles "bouncing" off the phase boundary) to the clouds forming Saturn (inside the phase boundary) or Neptune (outside the phase boundary), thus accounting for the substantial (relative to Jupiter) deviation of their rotation axes from exact perpendicularity (see images above and below from "Universe", 4th ed, by William Kaufmann, Freeman 1994).

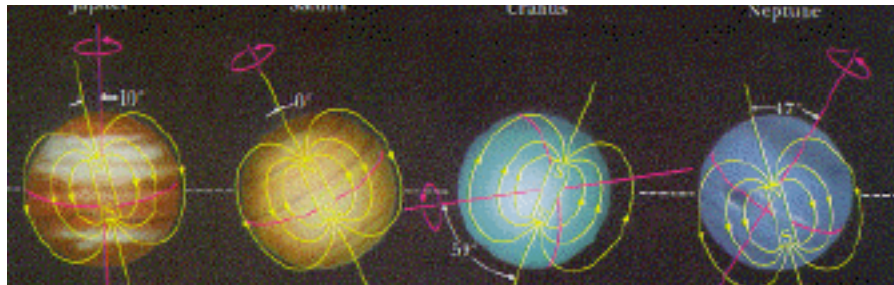

# Kepler's Polyhedra-Planet Correspondence can be extended to Uranus and Neptune by way of Cuboctahedron and Rhombic Dodecahedron

## Kepler Polyhedra and Planets

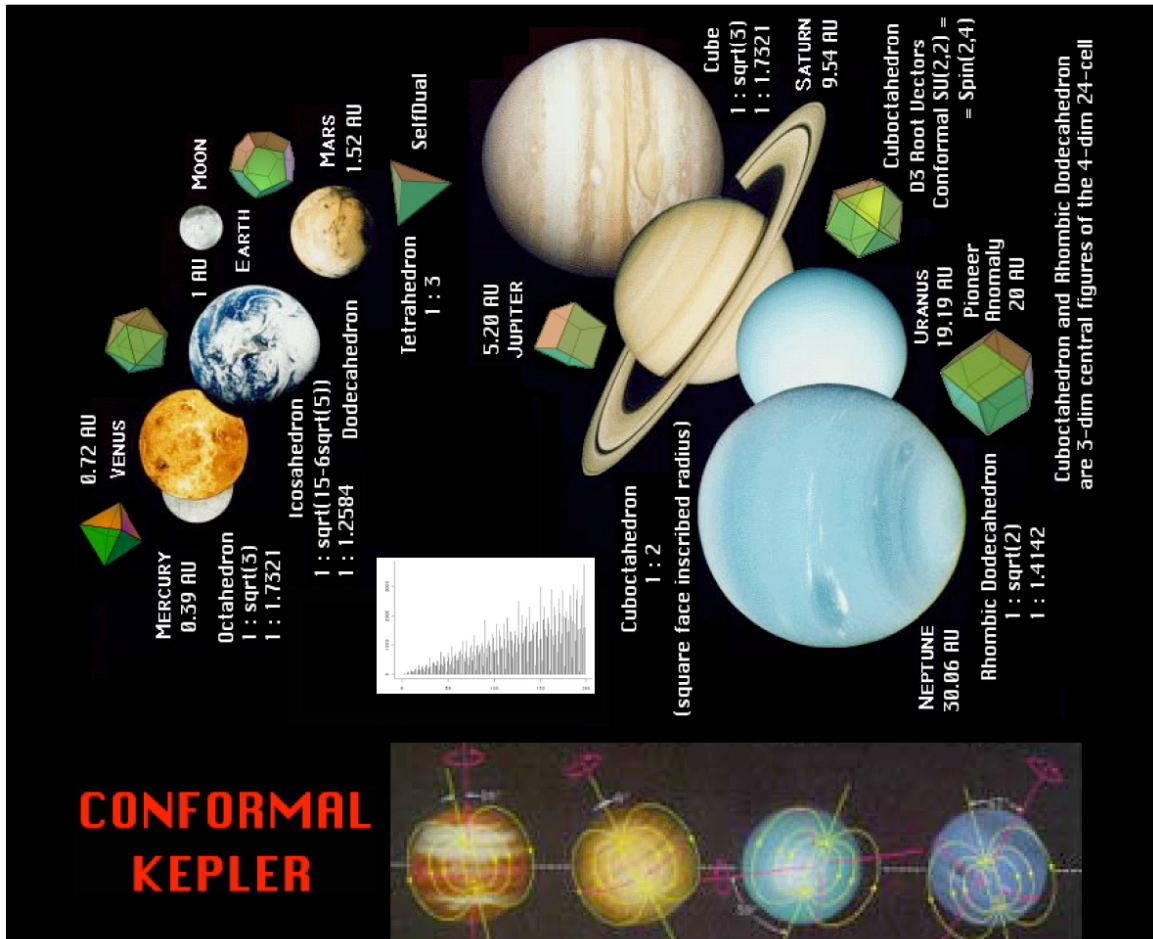

( images other than 24-cell are from, or adapted from, Wikipedia and Wolfram MathWorld )

Mercury = Outer Sun-Sphere = **Inner Octahedron**

Octahedron = 6 space Axes

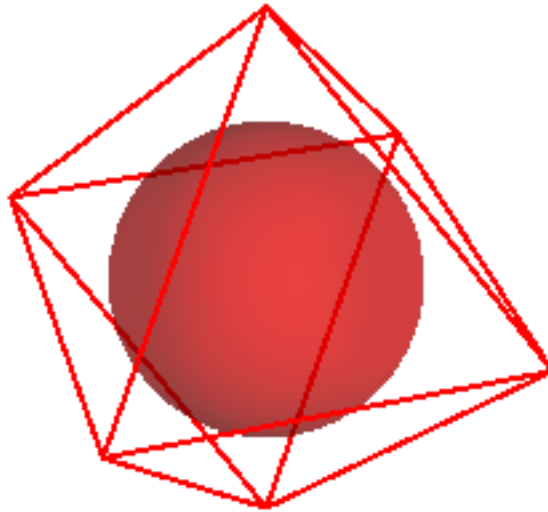

Venus / Mercury = 0.72 / 0.39 = 1.85

$$\text{Octahedron Outer / Inner} = \sqrt{3} / 1 = \frac{a}{2}\sqrt{2} \approx 0.707 \cdot a \quad / \quad \frac{a}{6}\sqrt{6} \approx 0.408 \cdot a = 1.732$$

Venus = **Outer Octahedron** = Inner Icosahedron

Icosahedron = 12 Golden Edge-Points of Octahedron

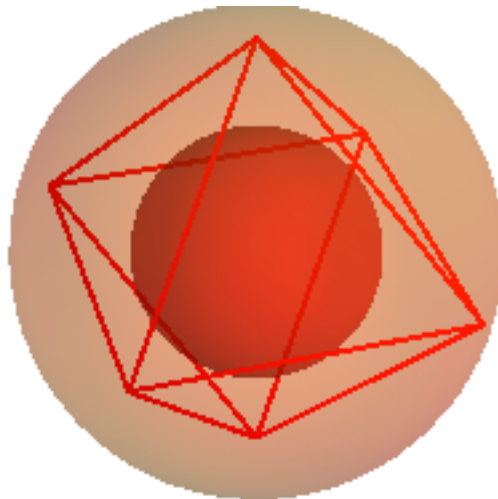

Earth / Venus = 1 / 0.72 = 1.39

$$\text{Icosahedron Outer / Inner} = \frac{a}{2} \sqrt{\phi\sqrt{5}} = \frac{a}{4} \sqrt{10 + 2\sqrt{5}} = a \sin \frac{2\pi}{5} \approx 0.9510565163 \cdot a \quad \Bigg/ \quad \frac{\phi^2 a}{2\sqrt{3}} = \frac{\sqrt{3}}{12} (3 + \sqrt{5}) a \approx 0.7557613141 \cdot a \approx 1.26$$

Earth = **Outer Icosahedron** = Inner Dodecahedron

Icosahedron = 2 Octahedral embeddings = Earth + Moon

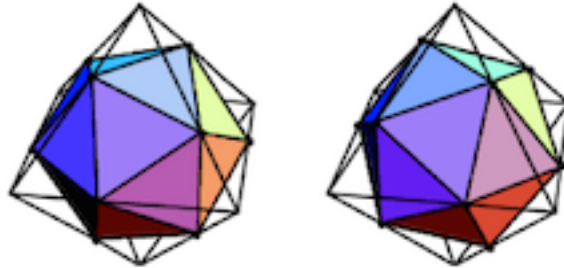

Dodecahedron = Dual Icosahedron

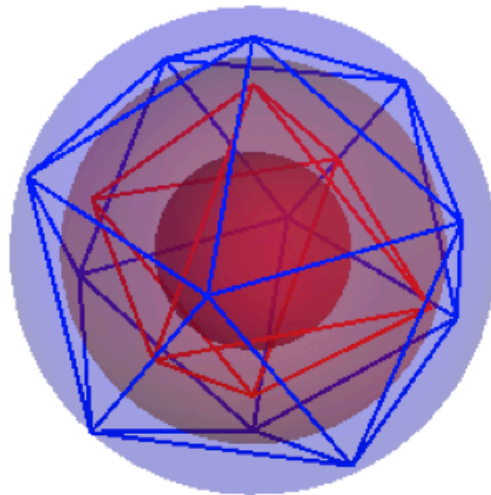

Mars / Earth = 1.52 / 1 = 1.52

$$\text{Dodecahedron Outer / Inner} = \frac{\sqrt{3}}{4} (1 + \sqrt{5}) \approx 1.401\,258\,538 \quad / \quad \frac{1}{2} \sqrt{\frac{5}{2} + \frac{11}{10} \sqrt{5}} \approx 1.113\,516\,364 \approx 1.26$$

Since Earth+Moon has 2 Outer Icosahedra, use  $1.26 \times 1.26 = 1.59$

Mars = **Outer Dodecahedron** = Inner Tetrahedron

Tetrahedron = 4 / 20 of Dodecahedron Vertices

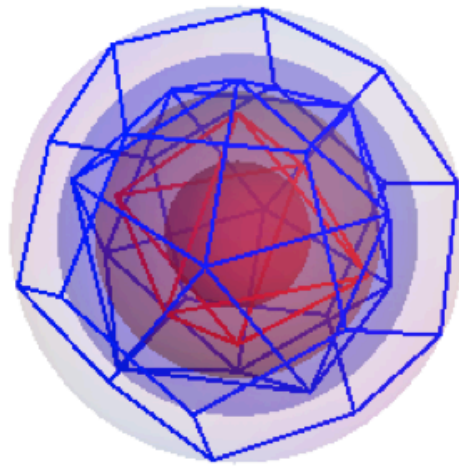

Tetrahedron = self-dual => stellated octahedron => unstable = Asteroids

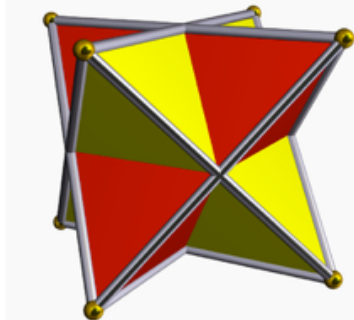

$$\text{Jupiter / Mars} = 5.2 / 1.52 = 3.42$$

$$\text{Tetrahedron Outer / Inner} = \sqrt{\frac{3}{8}} a \bigg/ \frac{a}{\sqrt{24}} = 3$$

Jupiter = **Outer Tetrahedron** = Inner Cube

Cube = 2 Tetrahedron Vertices = Dual Octahedron

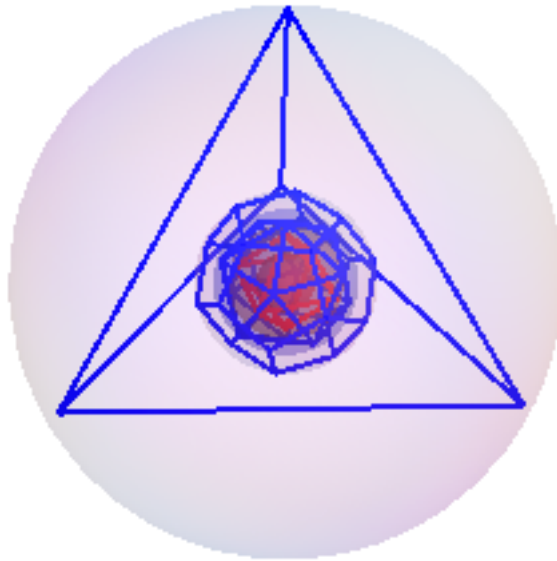



$$\text{Saturn / Jupiter} = 9.54 / 5.20 = 1.83$$

$$\text{Cube Outer / Inner} = \frac{\sqrt{3}}{2}a \bigg/ \frac{a}{2} = \sqrt{3} = 1.732$$

Saturn = **Outer Cube** = Inner CubOctahedron

Cuboctahedron = Truncated Cube

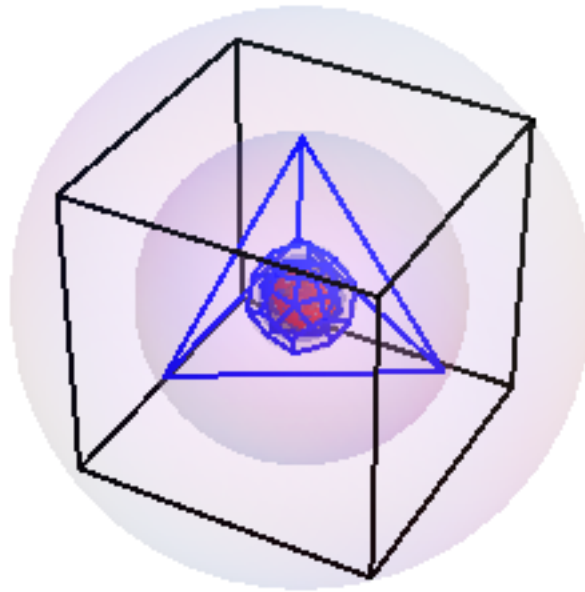

Poincare Gravity Space = Tiled by Cube

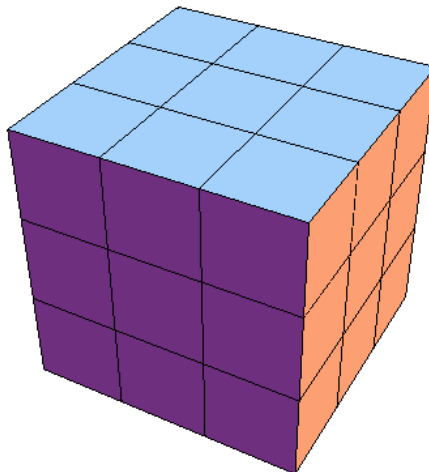

Uranus / Saturn = 19.19 / 9.54 = 2.01

$$\text{CubOctahedron Outer (dilated by Basic Cube Edge / CubOcta Edge) / Inner (square face)} = \sqrt{2} / \frac{1}{2} \sqrt{2} = 2$$

Uranus = **Outer CubOctahedron** = Inner Rhombic Dodecahedron

Rhombic Dodecahedron = Dual Cuboctahedron

Cuboctahedron containing Cube of centers of Triangle Faces and

Cuboctahedron within Basic Cube prior to Truncation

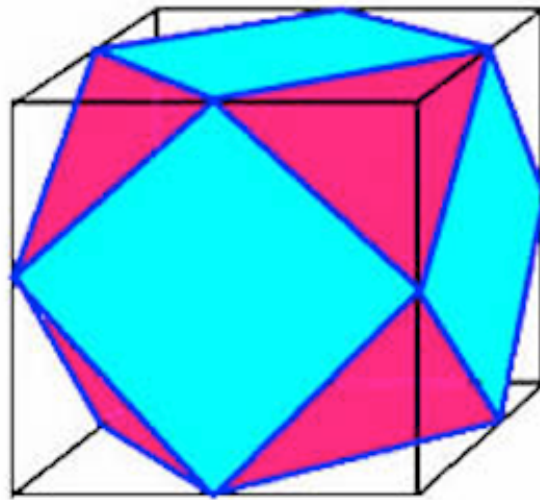
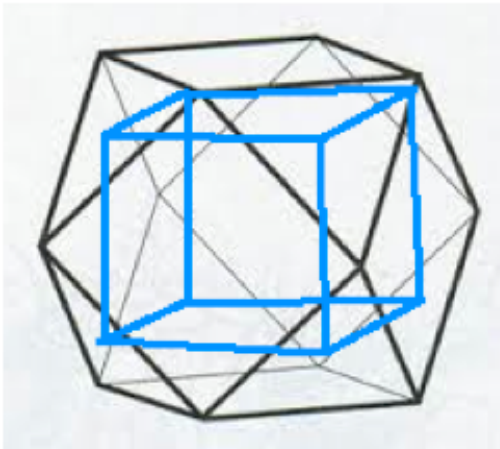

Uranus Orbit = Boundary of Pioneer Conformal Gravity Dark Energy

Cuboctahedron = Buckminster Fuller Vector Equilibrium = Center of 4-dim 24-cell

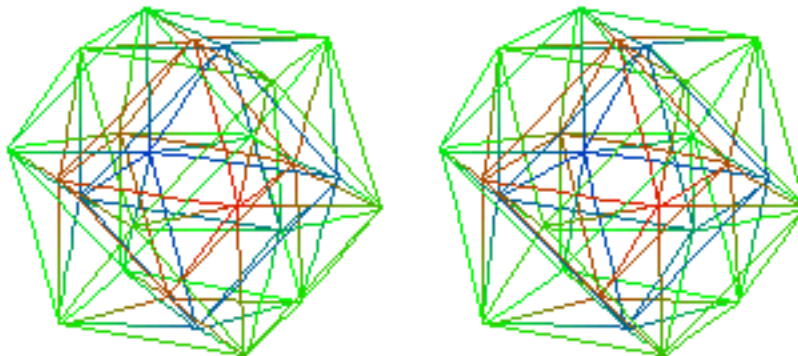

Neptune / Uranus= 30.06 / 19.19 = 1.57

$$\text{Rhombic Dodecahedron Outer / Inner} = \frac{2\sqrt{3}}{3}a \approx 1.154700538a \quad / \quad \frac{\sqrt{6}}{3}a \approx 0.8164965809a = \sqrt{2} = 1.414$$

Neptune = **Outer Rhombic Dodecahedron** = Inner Conformal Gravity Space

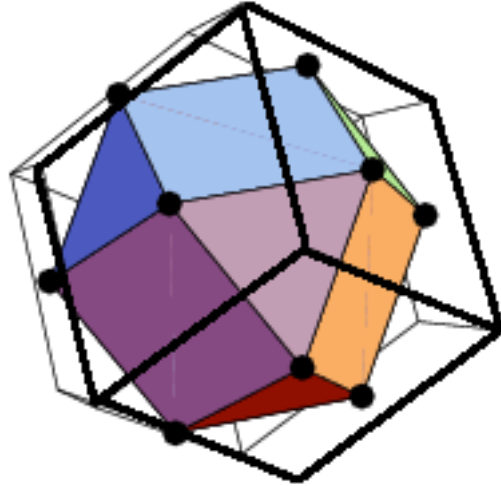

Rhombic Dodecahedron = Center of 4-dim 24-cell

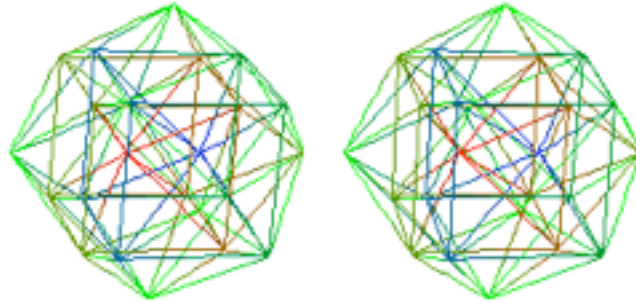

Conformal Gravity Space = Tiled by Rhombic Dodecahedra

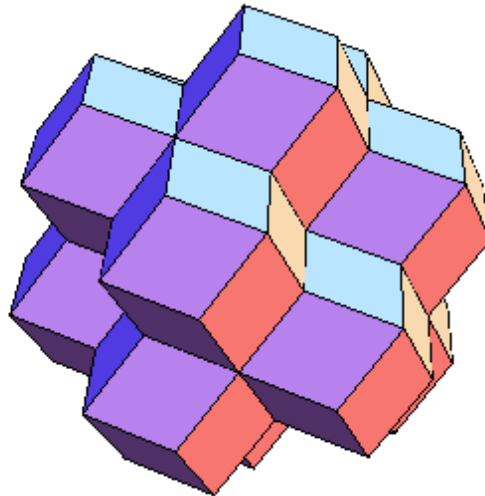

# Conformal Gravity + Dark Energy and Warp Drive

Gabriele U. Variaschi and Zily Burstein in arXiv 1208.3706 showed that with Conformal Gravity Alcubierre Warp Drive does not need Exotic Matter.

In E8 Physics of viXra 1602.0319 Conformal Gravity gives Dark Energy which expands our Universe and can curve Spacetime.

Clovis Jacinto de Matos and Christian Beck in arXiv 0707.1797 said "... based on the model of dark energy a proposed by Beck and Mackey ... assume... that photons ... can exist in two different phases:

A gravitationally active phase where the zeropoint fluctuations contribute to the [dark energy] cosmological constant  $\Lambda$ ,

and a gravitationally inactive phase where they do not contribute to  $\Lambda$ .

... this type of model of dark energy can lead to measurable effects in superconductors, via ... interaction with the Cooper pairs in the superconductor. ...

the transition between the two graviphoton's phases ... occurs at the critical temperature  $T_c$  of the superconductor, which defines a cutoff frequency of opoint fluctuations ...

Graviphotons can form weakly bounded states with Cooper pairs ...

[which] ... form a condensate ...[in]... superconduct[ors] ...

the cosmological cutoff frequency [could be measured] through the measurement of the spectral density of the noise current in resistively shunted Josephson Junctions ...".

Xiao Hu and Shi-Zeng Lin in arXiv 0911.5371 and 1206.516 showed that BSCCO superconducting crystals are natural Josephson Junctions.

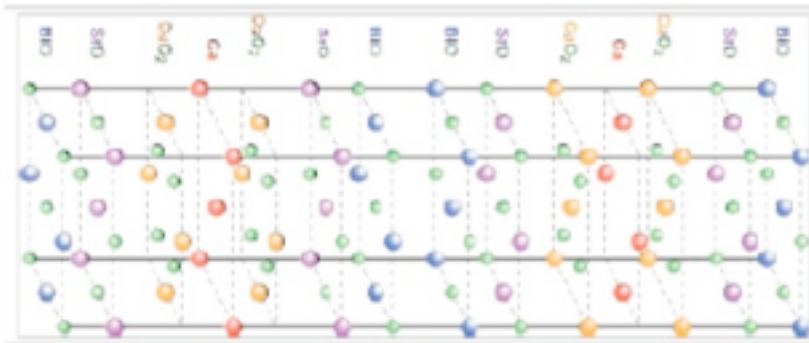

(BSCCO image from Wikipedia)

A Pentagonal Dipyramid configuration of 16 BSCCO crystals cannot close in flat 3-dim space, but can close if Conformal Dark Energy accumulated in the BSCCO Josephson Junctions curves spacetime. Such spacetime curvature allows construction of a Conformal Gravity Alcubierre Warp Drive that does not need Exotic Matter.

"... If you spend any time playing with Geomag models, you are sure to stumble upon the structure ...

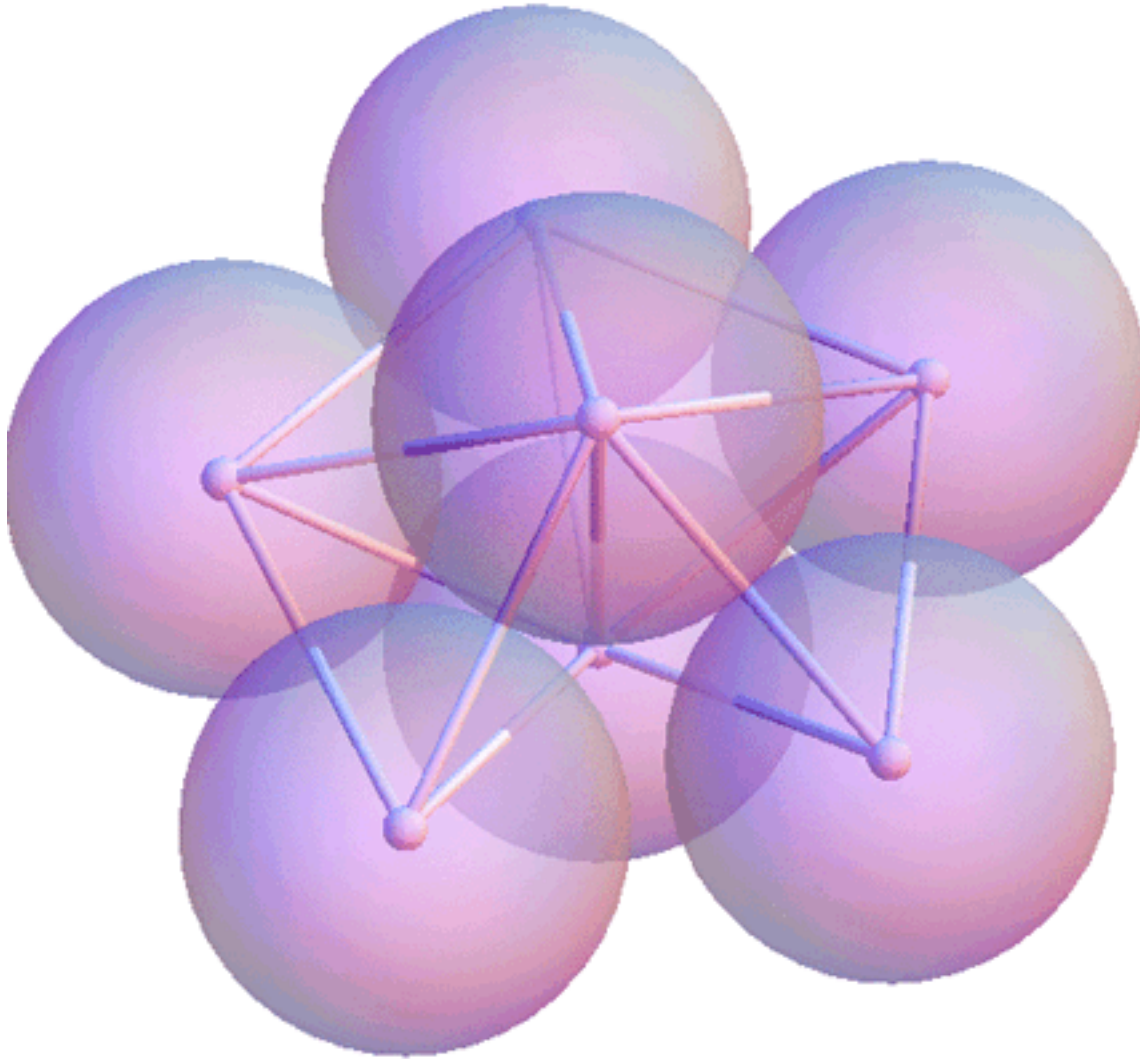

... which consists of four tetrahedra joined along faces. It looks as if you might be able to add one more bond to close the gap, creating a solid of five joined tetrahedra. But it doesn't work. The gap is slightly too wide. ..." ( [bit-player.org/2012/dancing-with-the-spheres](http://bit-player.org/2012/dancing-with-the-spheres) )

To close the 7.36 degree gap,  
you can contract space in the tetrahedron containing the gap,  
keep unchanged the space in the other 4 tetrahedra, and  
expand space just outside the structure and opposite to the gap tetrahedron.

In these images ( from simplydifferently.org/Present/Data/Johnson\_Solid/13.jpg )

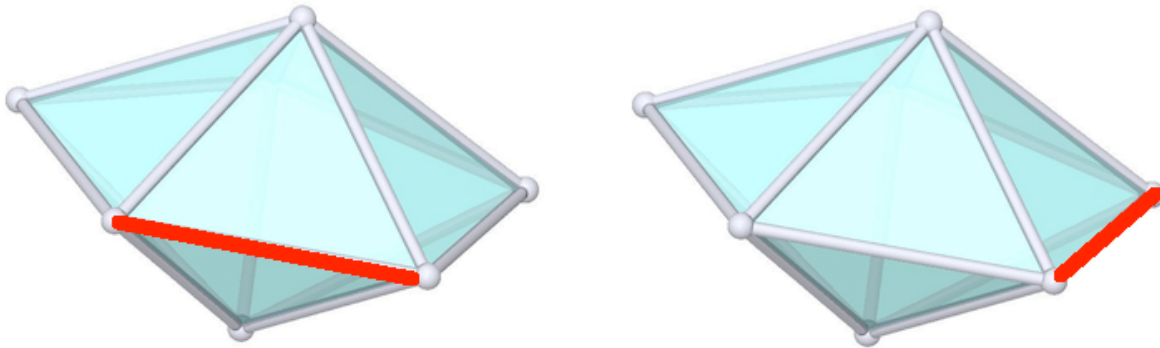

the red edge designates two of the choices of which tetrahedron contains the gap and  
in this image (from Wikipedia on Alcubierre drive )

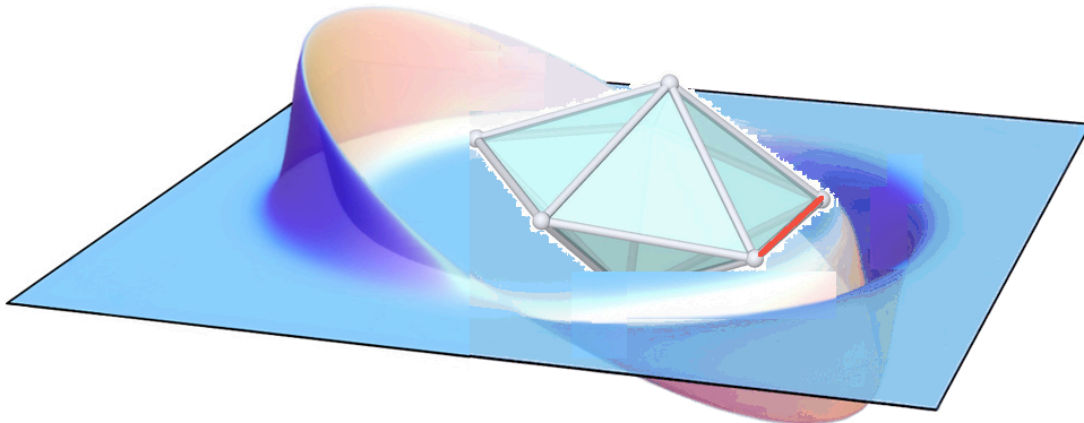

the structure is shown with space contracting in front of the gap tetrahedron and expanding behind the structure.

“... Alcubierre drive (Wikipedia) ... Rather than exceeding the speed of light within a local reference frame, **a spacecraft would traverse distances by contracting space in front of it and expanding space behind it,** resulting in effective faster-than-light travel ... the Alcubierre drive shifts space around an object so that the object would arrive at its destination faster than light would in normal space ...”.

The Alcubierre Warp Drive ( by John G. Cramer, Alternate View Column AV-81 )

“... General relativity does not forbid faster-than-light [FTL] travel or communication, but it does require that the local restrictions of special relativity must apply ... One example of this is a wormhole connecting two widely separated locations in space ... by transiting the wormhole the object has traveled ...[at]... an effective speed of ...[many]... times the velocity of light.

Another example of FTL in general relativity is the expansion of the universe itself. As the universe expands, new space is being created between any two separated objects. The objects may be at rest with respect to their local environment and with respect to the cosmic microwave background, but the distance between them may grow at a rate greater than the velocity of light. According to the standard model of cosmology, parts of the universe are receding from us at FTL speeds, and therefore are completely isolated from us

...

Alcubierre has proposed a way of beating the FTL speed limit that is somewhat like the expansion of the universe, but on a more local scale. He has developed a "metric" for general relativity ... that describes a region of flat space surrounded by a "warp" that propels it forward at any arbitrary velocity, including FTL speeds. Alcubierre's warp is constructed of hyperbolic tangent functions which create a very peculiar distortion of space at the edges of the flat-space volume. In effect, new space is rapidly being created ... at the back side of the moving volume, and existing space is being annihilated ... at the front side of the moving volume.

Thus,

a space ship within the volume of the Alcubierre warp (and the volume itself) would be pushed forward by the expansion of space at its rear and the contraction of space in front.

Here's a figure from Alcubierre's paper showing the curvature of space ...

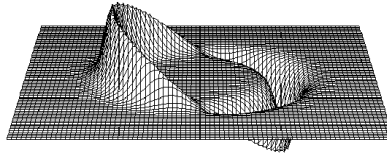

... Since a ship at the center of the moving volume of the metric is at rest with respect to locally flat space, there are no relativistic mass increase or time dilation effects. The on-board spaceship clock runs at the same speed as the clock of an external observer, and that observer will detect no increase in the mass of the moving ship, even when it travels at FTL speeds. Moreover, Alcubierre has shown that even when the ship is accelerating, it travels on a free-fall geodesic. In other words, a ship using the warp to accelerate and decelerate is always in free fall, and the crew would experience no accelerational gee-forces. Enormous tidal forces would be present near the edges of the flat-space volume because of the large space curvature there, but by suitable specification of the metric, these would be made very small within the volume occupied by the ship ...”.

( image below from George Dvorsky in Daily Explainer 11/26/12 at io9.gizmodo.com )

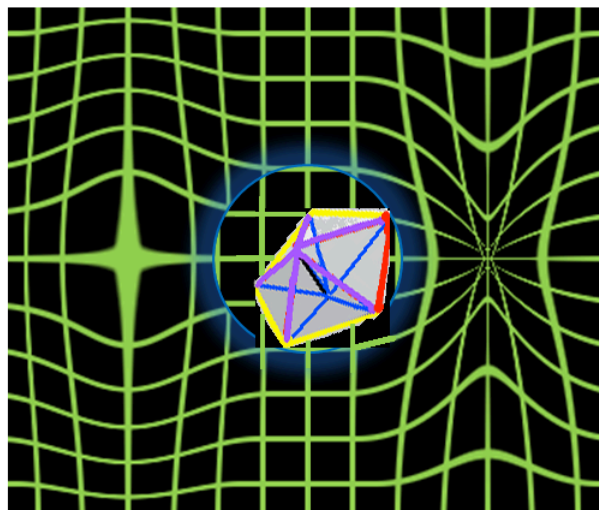

# Standard Model Gauge Bosons and Ghosts

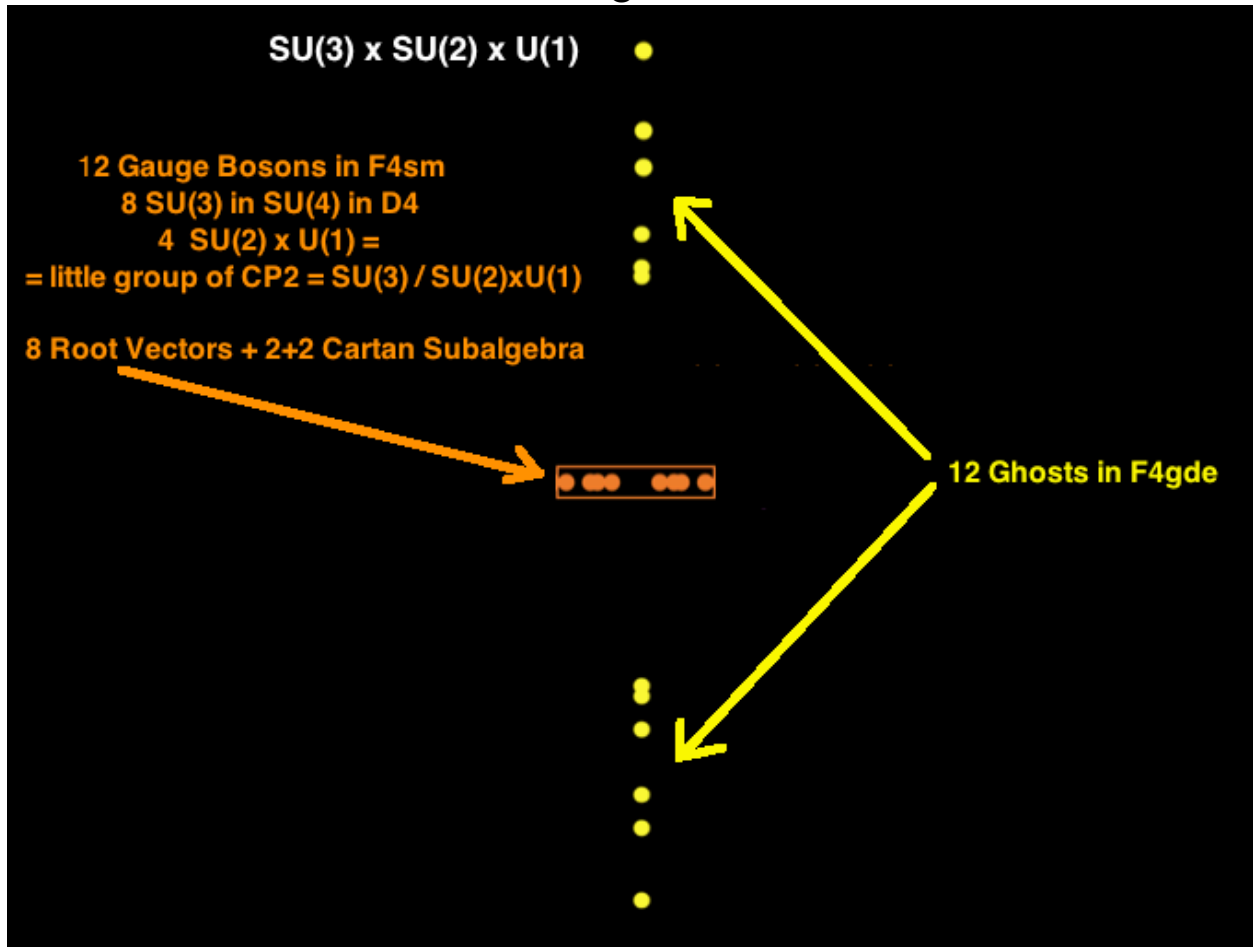



These  $1 + 3 + 8 = 12$  grade-2 Cellular Automata correspond to  $U(1)$ ,  $SU(2)$ ,  $SU(3)$  of the Standard Model

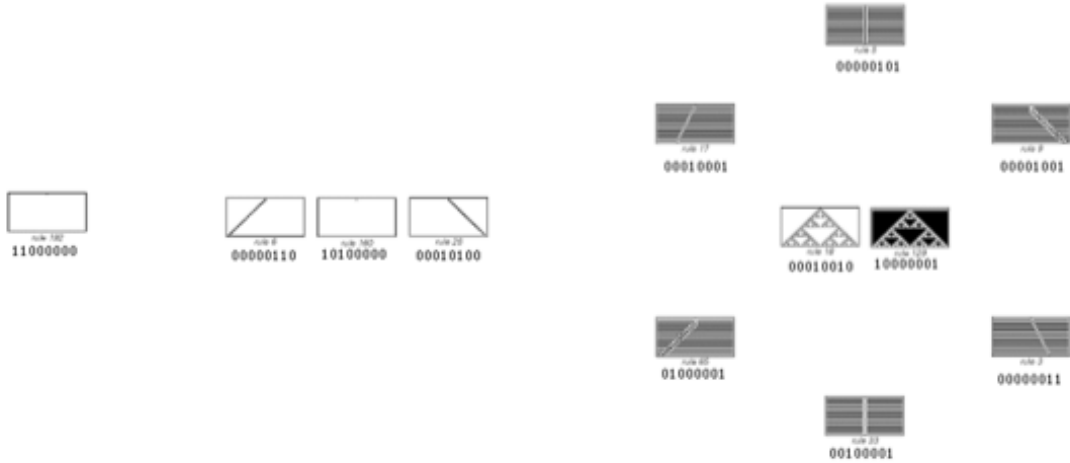

Here is how they fit into the Lagrangian:

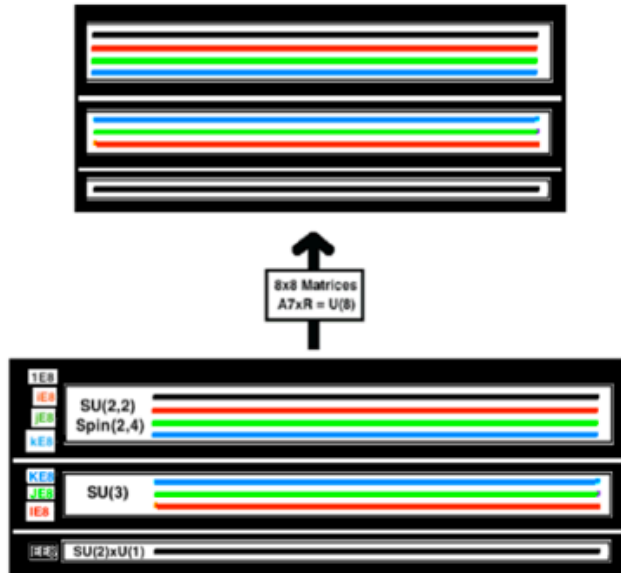
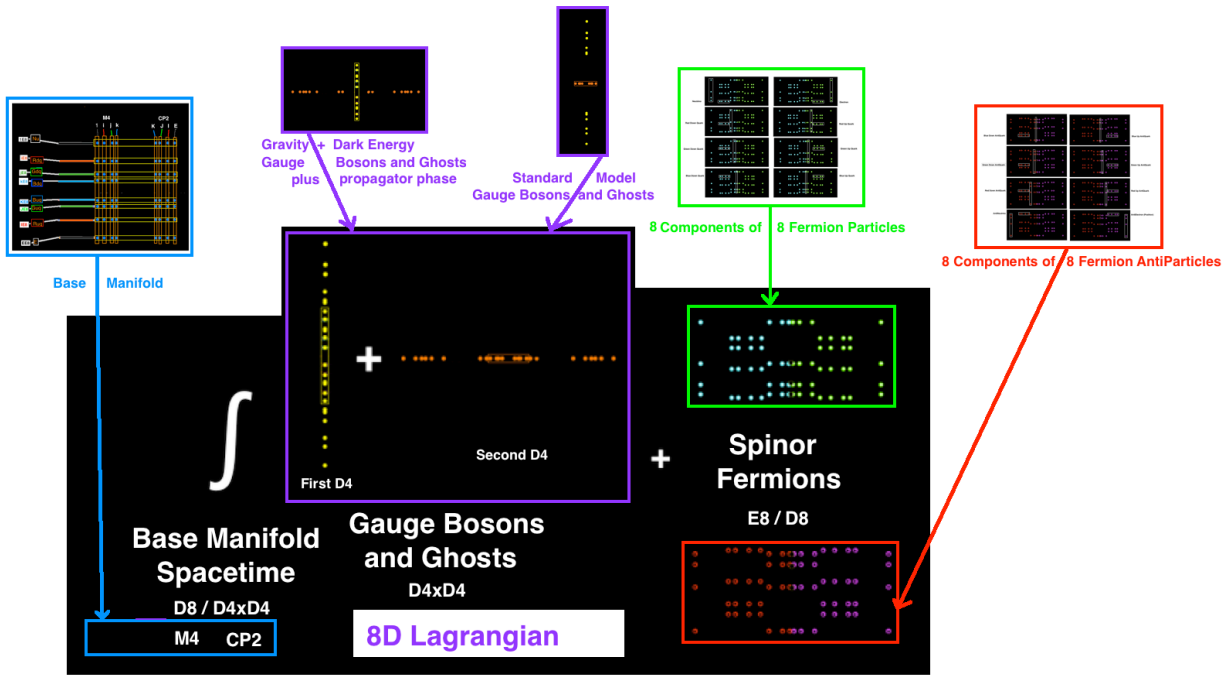

Gauge Bosons from  $1E8$ ,  $iE8$ ,  $jE8$ , and  $kE8$  parts of a  $\mathbf{V}$  give  $U(2,2)$  Conformal Gravity  
 Gauge Bosons from  $IE8$ ,  $JE8$ , and  $KE8$  parts of a  $\mathbf{V}$  give  $SU(3)$  Color Force  
 Gauge Bosons from  $EE8$  part of a  $\mathbf{V}$  give  $U(2)$  Electroweak Force  
 Ghosts from one  $\mathbf{V}$  Spacetime Superposition to the next are defined similarly.

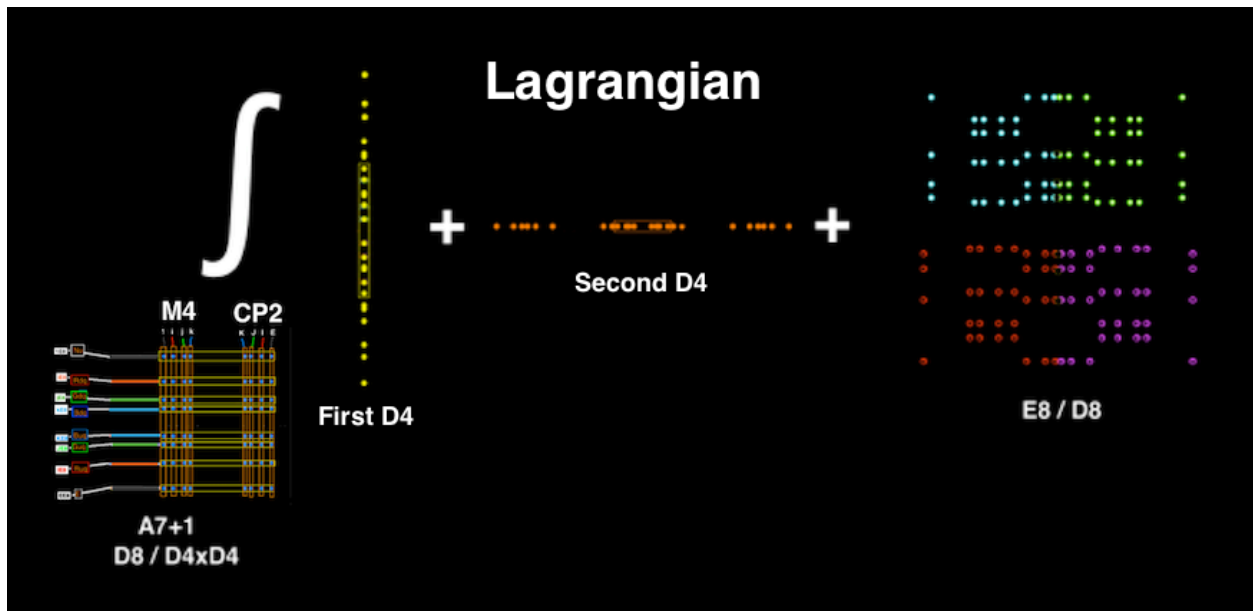

The 8D Lagrangian has 4 fundamental terms:

The 8D Lagrangian Base Manifold  $D8 / D4 \times D4$  is  $M4 \times CP2$  Kaluza-Klein of Superposition of 8  $E8$  Lattices  $(4+4) \times 8 = 64$  Root Vectors

Gravity+Dark Energy  $D4$  Gauge Bosons  
and Standard Model Ghosts plus  $U(1)$  Propagator Phase  
24 Root Vectors and  
4 Cartan Subalgebra elements of  $M4$  part of  $E8$  Physics

Standard Model  $D4$  Gauge Bosons  
and Gravity+Dark Energy Ghosts  
24 Root Vectors and  
4 Cartan Subalgebra elements of  $CP2$  part of  $E8$  Physics

Fermion Particles and AntiParticles in  $E8 / D8$   
 $(8+8) \times 8$  Components =  $64+64 = 128$  Root Vectors

Lagrangian 8-dim Lorentz structure  
satisfies Coleman-Mandula  
because its Fermionic fundamental spinor representations  
are built with respect to spinor representations  
for 8-dim Spin(1,7) spacetime.

Reference: Steven Weinberg  
“The Quantum Theory of Fields” Volume III

Each Fermionic Term Fermion has in 8-dim Spacetime units of  $\text{mass}^{(7/2)}$ .

Each Bosonic Term Gauge Boson + Ghost has units of  $\text{mass}^{(1)}$

Since  $(8+8) \times (7/2) = 56 = 28 + 28$

the Fermionic Terms cancel the Bosonic Terms so the E8 Physics Lagrangian is UltraViolet finite.

Reference: Steven Weinberg

“1986 Dirac Lectures

Elementary Particles and the Laws of Physics: “

The 26D Lagrangian Structure is

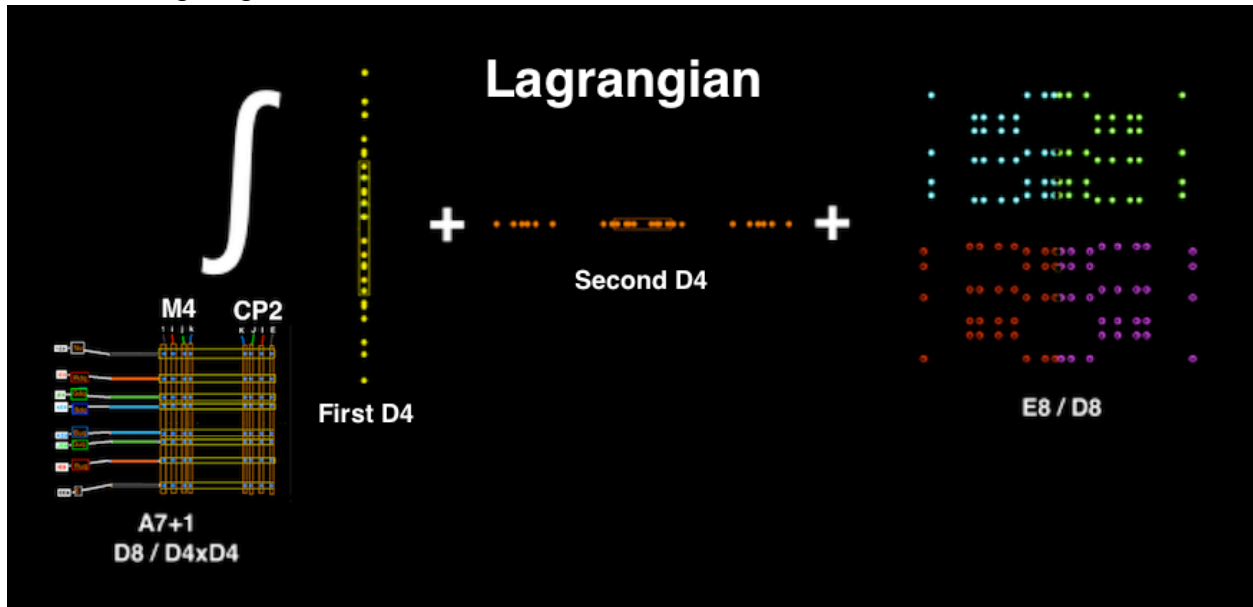

having terms for  
 E8 / D8 Fermions (with Fermion Generations 2 and 3 from Quaternionic structure)  
 and  
 D4 Standard Model Gauge Bosons and Gravity Ghosts  
 and  
 D4 Conformal Gravity Gauge Bosons and Standard Model Ghosts

that is integrated over  
 D8 / D4xD4 (4+4)-dim M4 x CP2 Kaluza-Klein base manifold  
 with Higgs from the Mayer mechanism

**The E8 Lagrangian is Chiral** because

E8 contains  $Cl(16)$  half-spinors (64+64) for a Fermion Generation  
 but does not contain  $Cl(16)$  Fermion AntiGeneration half-spinors (64+64).  
 Fermion +half-spinor Particles with high enough velocity are seen as left-handed.  
 Fermion -half-spinor AntiParticles with high enough velocity are seen as right-handed.

**The E8 Lagrangian obeys Spin-Statistics** because

the CP2 part of M4xCP2 Kaluza-Klein has index structure Euler number  $2+1 = 3$  and  
 Atiyah-Singer index  $-1/8$  which is not the net number of generations because

**CP2 has no spin structure but you can use a generalized spin structure**

(Hawking and Pope (Phys. Lett. 73B (1978) 42-44))

**to get (for integral m) the generalized CP2 index  $n_R - n_L = (1/2) m (m+1)$**

Prior to Dimensional Reduction:  $m = 1$ ,  $n_R - n_L = (1/2) \times 1 \times 2 = 1$  for 1 generation  
 After Reduction to 4+4 Kaluza-Klein:  $m = 2$ ,  $n_R - n_L = (1/2) \times 2 \times 3 = 3$  for 3 generations

Hawking and Pope say: "Generalized Spin Structures in Quantum Gravity ...what happens in CP2 ... is a two-surface K which cannot be shrunk to zero. ... However, one could replace the electromagnetic field by a Yang-Mills field whose group G had a double covering  $G\sim$ . The fermion field would have to occur in representations which changed sign under the non-trivial element of the kernel of the projection ...  $G\sim \rightarrow G$  while the bosons would have to occur in representations which did not change sign ...".

For the E8 model gauge bosons are in the  $28+28=56$ -dim D4 + D4 subalgebra of E8. D4 = SO(8) is the Hawking-Pope G which has double covering  $G\sim = \text{Spin}(8)$ .

The 8 fermion particles / antiparticles are D4 half-spinors represented within E8 by anti-commutators and so do change sign while the 28 gauge bosons are D4 adjoint represented within E8 by commutators and so do not change sign.

**E8 inherits from F4 the property whereby  
its Spinor Part need not be written as Commutators  
but can also be written in terms of Fermionic AntiCommutators.**

Pierre Ramond has shown in hep-th/0112261 as shown that the exceptional Lie Algebra F4 can be described using anticommutators as well as commutators. The periodicity property of Real Clifford Algebras shows that E8 Spinor Fermions can also be described using anticommutators as well as commutators so that the E8 Physics model describes both Bosons and Fermions realistically.

Realistic Physics models must describe both integer-spin Bosons whose statistics are described by commutators (examples are Photons, W and Z bosons, Gluons, Gravitons, Higgs bosons) and half-integer-spin Fermions whose statistics are described by anticommutators. (examples are 3 generations of Electrons, Neutrinos, Quarks and their antiparticles)

Lie Algebra elements are usually described by commutators of their elements so if a Physics model attempts to describe both Bosons and Fermions as elements of a single unifying Lie Algebra (for example, Garrett Lisi's E8 TOE) a common objection is:

since the Lie Algebra is described by commutators,  
it can only describe Bosons and cannot describe Fermions  
therefore  
models (such as Garrett Lisi's) using E8 as a single unifying Lie Algebra  
violate the consistency of spin and statistics  
and are wrong.

However,  
Pierre Ramond has shown in hep-th/0112261 as shown that the exceptional Lie Algebra F4 can be described using anticommutators as well as commutators.

The periodicity property of Real Clifford Algebras shows that E8 inherits from F4 a description using anticommutators as well as commutators so that it may be possible to construct a realistic Physics model that uses the exceptional Lie Algebra E8 to describe both Bosons and Fermions.

Here are relevant quotes from hep-th/0112261 by Pierre Ramond:

"... exceptional algebras relate tensor and spinor representations of their orthogonal subgroups, while Spin-Statistics requires them to be treated differently ... all representations of the exceptional group F4 are generated by three sets of oscillators transforming as 26. We label each copy of 26 oscillators as  $A_{k_0}$ ,  $A_{k_i}$ ,  $i = 1, \dots, 9$ ,  $B_{k_a}$ ,  $a = 1, \dots, 16$ , and their hermitian conjugates, and where  $k = 1, 2, 3$ .

... One can ...

use a coordinate representation of the oscillators by introducing real coordinates ... [ for  $A_i$  ]... which transform as transverse space vectors, ... [ for  $A_0$  ]... which transform ... as scalars, and ... [ for  $B_a$  ]... which transform ... as space spinors which satisfy Bose commutation rules ...

Under SO(9), the  $A_{k_i}$  transform as 9,  $B_{k_a}$  transform as 16, and  $A_{k_0}$  is a scalar.

They satisfy the commutation relations of ordinary harmonic oscillators ...

Note that the SO(9) spinor operators satisfy Bose-like commutation relations ...

both  $A_0$  and  $B_a$  ... obey Bose commutation relations

... Curiously,

if both ...  $A_0$  and  $B_a$  ... are anticommuting, the F4 algebra is still satisfied ...".

To see how the anticommuting property of the 16  $B_a$  elements of F4 can be inherited by some of the elements of E8, consider that 52-dimensional F4 is made up of:

28-dimensional D4 Lie Algebra Spin(8) (in commutator part of F4)

8-dimensional D4 Vector Representation V8 (in commutator part of F4)

8-dimensional D4 +half-Spinor Representation S+8 (in anticommutator part of F4)

8-dimensional D4 -half-Spinor Representation S-8 (in anticommutator part of F4)

Since 28-dimensional D4 Spin(8) is the BiVector part BV28

of the Real Clifford Algebra Cl(8) with graded structure

$Cl(8) = 1 + V8 + BV28 + 56 + 70 + 56 + 28 + 8 + 1$

and with Spinor structure

$Cl(8) = (S+8 + S-8) \times (8 + 8)$

F4 can be embedded in Cl(8) (blue commutator part, red anticommutator part):

$F4 = V8 + BV28 + S+8 + S-8$

Note that V8 and S+8 and S-8 are related by the Triality Automorphism.



Also consider the 8-periodicity of Real Clifford Algebras, according to which for all N

$$Cl(8N) = Cl(8) \times \dots (N \text{ times tensor product}) \dots Cl(8)$$

so that in particular  $Cl(16) = Cl(8) \times Cl(8)$

where  $Cl(16)$  graded structure is  $1 + 16 + BV120 + 560 + \dots + 16 + 1$

and  $Cl(16)$  Spinor structure is  $((S+64 + S-64) + (64 + 64)) \times (128 + 128)$

and  $Cl(16)$  contains 248-dimensional E8 as

$$E8 = BV120 + S+64 + S-64$$

where  $BV120 = 120\text{-dimensional D8 Lie Algebra Spin}(16)$

and  $S+64 + S-64 = 128\text{-dimensional D8 half-Spinor Representation}$

Consider two copies of F4 embedded into two copies of  $Cl(8)$ .

**For commutator structure:**

The tensor product of the two copies of  $Cl(8)$  can be seen as

$$\begin{aligned} &1 + V8 + BV28 + 56 + 70 + 56 + 28 + 8 + 1 \\ &\quad \times \\ &1 + V8 + BV28 + 56 + 70 + 56 + 28 + 8 + 1 \end{aligned}$$

which produces the Real Clifford Algebra  $Cl(16)$  with graded structure

$$1 + 16 + BV120 + 560 + 1820 + \dots + 16 + 1$$

where the  $Cl(16)$  BiVector BV120 is made up of 3 parts

$$BV120 = BV28 \times 1 + 1 \times BV28 + V8 \times V8$$

that come from the  $V8$  and  $BV28$  commutator parts of the two copies of F4.

This gives the commutator part of E8 as  $BV120$  inheriting commutator structure from the two copies of F4 embedded in two copies of  $Cl(8)$  whose tensor product produces  $Cl(16)$  containing E8.

**For anticommutator structure:**

The tensor product of the two copies of 256-dim Cl(8) can also be seen as

$$\begin{aligned} & ( (S+8 + S-8) \times (8 + 8) ) \\ & \quad \times \\ & ( (S+8 + S-8) \times (8 + 8) ) \end{aligned}$$

which produces the  $2^{16} = 65,536 = 256 \times 256$ -dim Real Clifford Algebra Cl(16)

$$\begin{aligned} & ( (S+8 + S-8) \times (S+8 + S-8) ) \\ & \quad \times \\ & ( (8 + 8) \times (8 + 8) ) \end{aligned}$$

with 256-dimensional Spinor structure

$$\begin{aligned} & ( (S+8 + S-8) \times (S+8 + S-8) ) = \\ & = ( (S+8 \times S+8) + (S-8 \times S-8) ) + ( (S+8 \times S-8) + (S-8 \times S+8) ) \end{aligned}$$

that comes from the S+8 and S-8 anticommutator parts of the two copies of F4.

Since the (S+8 x S-8) and (S-8 x S+8) terms inherit mixed helicities from F4

only the (S+8 x S+8) and (S-8 x S-8) terms inherit consistent helicity from F4.

Therefore, define S+64 = (S+8 x S+8) and S-64 = (S-8 x S-8)  
so that

$$( S+64 + S-64 ) = 128\text{-dimensional D8 half-Spinor Representation}$$

This gives the anticommutator part of E8 as S+64 + S-64 inheriting anticommutator structure from the two copies of F4 embedded in two copies of Cl(8) whose tensor product produces Cl(16) containing E8.

The result is that 248-dimensional E8 is made up of:

BV120 = 120-dimensional D8 Lie Algebra Spin(16) (commutator part of E8)

128-dimensional ( S+64 + S-64 ) D8 half-Spinor (anticommutator part of E8)

Note that since the V8 and S+8 and S-8 components of F4 are related by Triality, and since

the E8 component BV120 contains 64-dimensional V8xV8

and

the 64-dimensional E8 component S+64 = S+8 x S+8

and

the 64-dimensional E8 component S-64 = S-8 x S-8

E8 inherits from the two copies of F4 a Triality relation

$$V8xV8 = S+64 = S-64$$

The commutator - anticommutator structure of E8 allows construction of realistic Physics models that not only unify both Bosons and Fermions within E8

but

also contain Triality-based symmetries between Bosons and Fermions

that can give the useful results of SuperSymmetry

without requiring conventional SuperPartner particles that are unobserved by LHC.

### CONCLUSION:

Unified E8 Physics models can be constructed without violating spin-statistics.

The 8D Lagrangian gives  
2nd and 3rd Fermion Generations and Higgs

when its 8D Octonionic Spacetime symmetry  
is broken to  $M4 \times CP2$  Kaluza-Klein

where  $M4$  is 4D Minkowski Spacetime  
and  $CP2 = SU(3) / SU(2) \times U(1)$

Reference for  $M4 \times CP2$  Kaluza-Klein and Standard Model:

N. A. Batakis in *Class. Quantum Grav.* 3 (1986) L99-L105

References for Higgs and Nambu - Jona-Lasinio:

Meinhard Mayer and A. Trautman in  
“A Brief Introduction to the Geometry of Gauge Fields”

Meinhard Mayer in  
“The Geometry of Symmetry Breaking in Gauge Theories”,  
*Acta Physica Austriaca, Suppl.* XXIII (1981))

Shoshichi Kobayashi and Katsumi Nomizu in  
“Foundations of Differential Geometry Vol. I”,  
Interscience (1963)

Koichi Yamawaki in hep-ph/9603293

Michio Hashimoto, Masaharu Tanabashi, and Koichi Yamawaki  
in hep-ph/0311165

The next 3 pages indicate how that works:

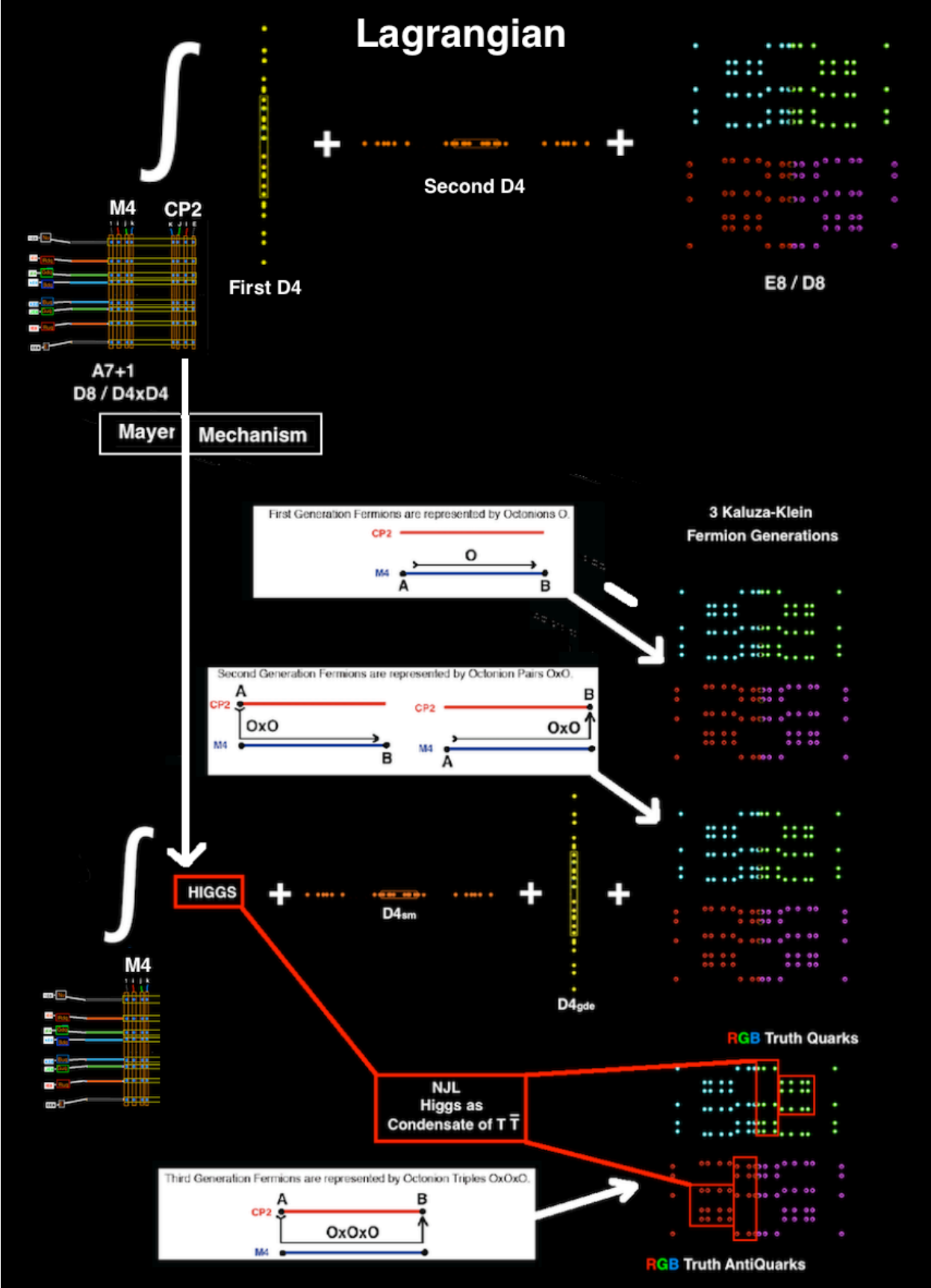

### 3 Generations of Fermions

In Kaluza-Klein  $M4 \times CP2$  there are 3 possibilities for a fermion to go from point A to point B:

1 - A and B are both in  $M4$ : First Generation Fermion represented by single O basis element

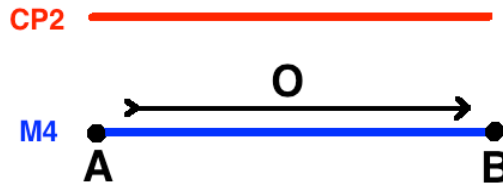

2 - Either A or B, but not both, is in  $CP2$ : Second Generation Fermion whose path must be augmented by one projection from  $CP2$  to  $M4$ , which projection can be represented by a second O basis element so that Second Generation Fermions are Octonion Pairs  $OxO$ .

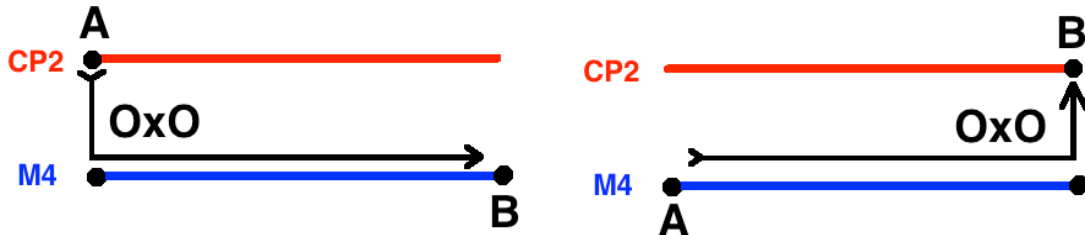

3 - Both A and B are in  $CP2$ : Third Generation Fermion whose path must be augmented by two projections from  $CP2$  to  $M4$ , which projections can be represented by a second O and a third O, so that Third Generation Fermions are Octonion Triples  $OxOxO$ .

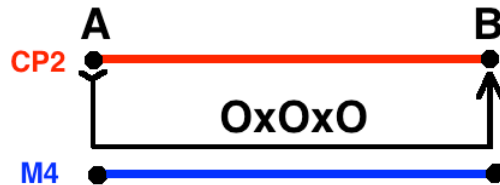

When Octonionic Spacetime of 8D Lagrangian symmetry  
 breaks to Quaternionic (4+4) Kaluza-Klein 4D Lagrangian  
 Higgs emerges by Mayer Mechanism  
 and  
 Higgs as Truth Quark-AntiQuark Condensate  
 form Nambu - Jona-Lasinio system  
 with 3 Mass States for Higgs and Truth Quark

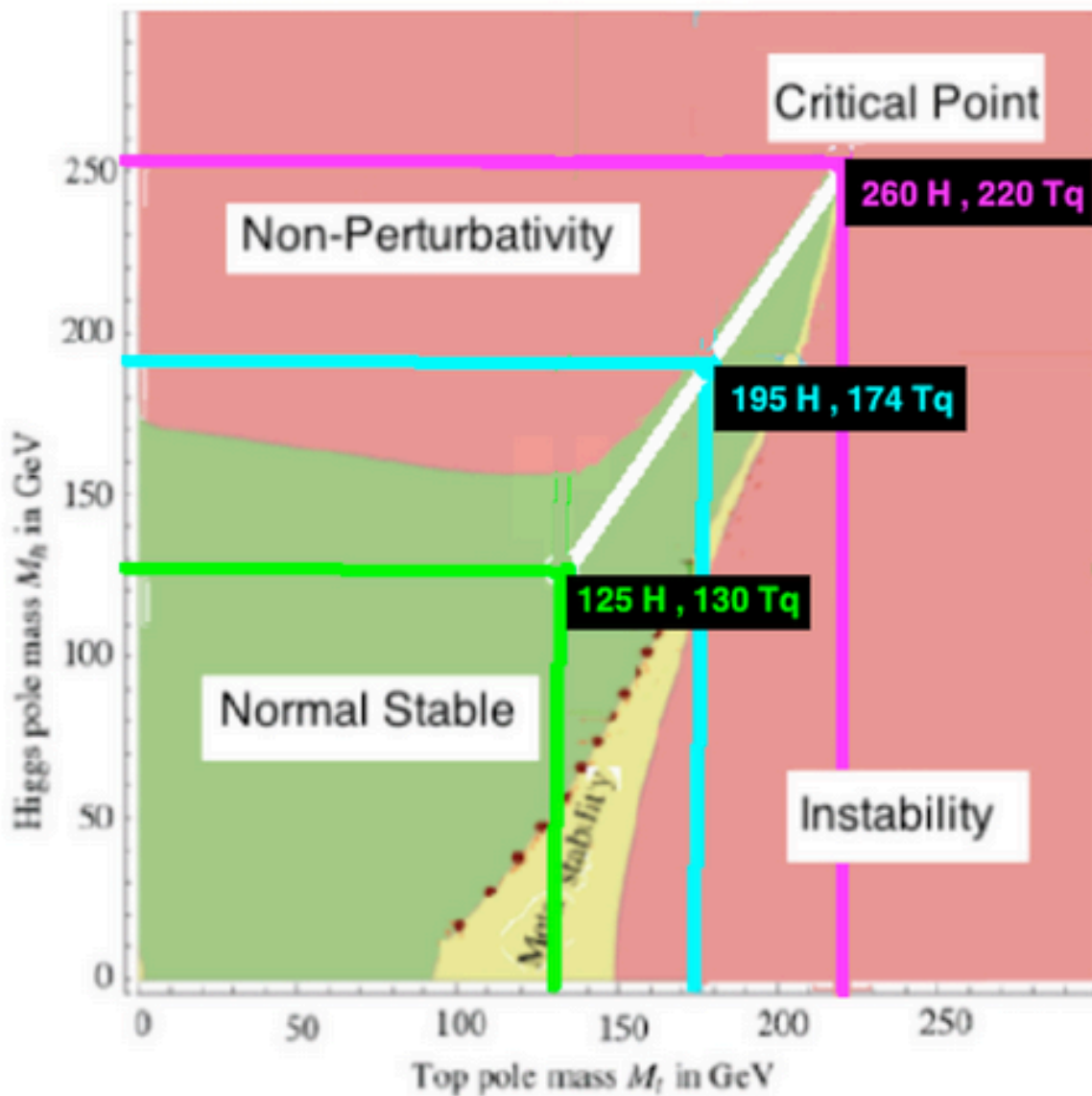

## C(16) TriVectors = 10 copies of Fr3(O)

**E8 Physics World-Lines = Strings as String Theory  
Fundamental Interactions are not among Point Particles  
but are among Strings = World-Line Histories of Particles.**

### David Finkelstein said

( "Space-Time Code. III" Phys. Rev. D (1972) 2922-2931 )

“... According to relativity,  
the world is a collection of processes (events}  
with an unexpectedly unified causal or chronological structure.  
Then an object is secondary ...[to]...  
a long causal sequence of processes, world line. ..  
[if] we assemble these ... into chromosomelike code sequences ...  
and braid and cross-link these strands  
to make more complex objects and their interactions  
...[then]... The idea of the quantum jump comes into its own ...”.

**Do the 56-dim grade-3 TriVectors of Cl(8)  
represent 26D String Theory of E8 Physics ?  
56-dim Freudenthal Algebra Fr3(O) = Zorn vector-matrices**

$$\begin{array}{ccc}
 & & \begin{array}{ccc} d & S^+ & V \end{array} \\
 & & \begin{array}{ccc} S^{+*} & e & S^- \end{array} \\
 a & & \begin{array}{ccc} V^* & S^{-*} & f \end{array} \\
 \\
 \begin{array}{ccc} d^t & S'^{+*} & V'^* \end{array} & & \\
 \begin{array}{ccc} S'^+ & e^t & S'^{-*} \end{array} & & b \\
 \begin{array}{ccc} V^t & S'^- & f^t \end{array} & & 
 \end{array}$$

where a, b, d, e, and f are real numbers;  
S<sup>+</sup>, V, S<sup>-</sup>, S'<sup>+</sup>, V', and S'<sup>-</sup> are Octonions;  
and \* denotes conjugation.



d	<b>S+</b>	V
<b>S+*</b>	e	<b>S-</b>
<b>V*</b>	<b>S-*</b>	f

is 27-dim  $J_3(O) = 3 \times 3$  Hermitian Octonion Matrices  
 whose traceless part is 26-dim  $J_3(O)_o$   
 that describes 26D String Theory  
 with

**V = 8-dim Spacetime**

the 8-real-dim space  $RP^1 \times S^7$  that is the Shilov Boundary  
 of the 16-real-dim  $IV(8,2)$  Bounded Domain (tube type)  
 of the BDI Symmetric Space  $Spin(10) / Spin(8) \times U(1)$

**S+ = 8 +half-Spinor Fermion Particles**

the real part  $RP^1 \times S^7$  of the Complex Shilov Boundary S  
 of the 32-real-dim V non-tube type bounded Domain  $(C \times O)P^2$   
 of the EIII Symmetric Space  $E_6 / Spin(10) \times U(1)$ .

**S- = 8 - half-Spinor Fermion AntiParticles**

$RP^1 \times S^7$  in the Complex part of the Shilov Boundary S of the 32-real-dim V non-tube  
 type bounded Domain  $(C \times O)P^2$  of the EIII Symmetric Space  $E_6 / Spin(10) \times U(1)$

$Fr_3(O)$  has two copies of  $J_3(O)$   
 and is a Complexification of  $J_3(O)_o$   
 and of 26D String Theory

so

**$Fr_3(O)$  is the structural basis  
 for E8 World-Lines = Strings Theory**

First  $Cl(8)$  D4 F4 acting on M4  
Graded Representation

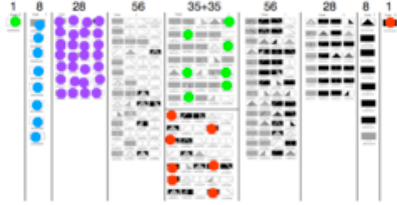

16x16 Matrix Representation

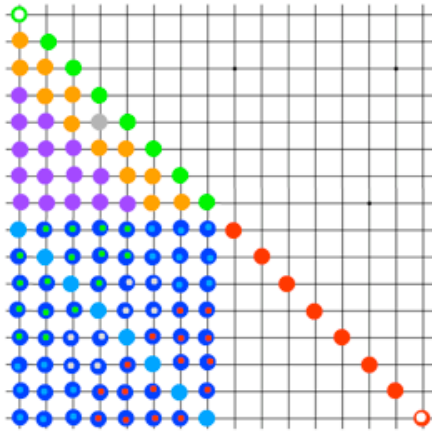

15 Purple = Spin(2,4) = SU(2,2) Gauge Bosons  
1 Grey = U(1) of U(2,2) Propagator Phase  
12 Orange = Standard Model Ghosts

Second  $Cl(8)$  D4 F4 acting on CP2  
Graded Representation

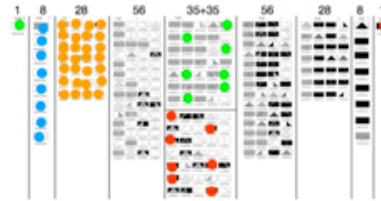

16x16 Matrix Representation

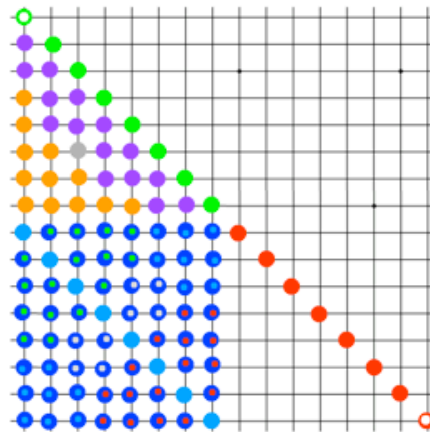

12 Orange = SU(3) x SU(2) x U(1) Gauge Bosons  
1 Grey = U(1) of U(3) Propagator Phase  
15 Purple = Gravity + Dark Energy Ghosts

## $Cl(8)$ TriVectors correspond to $Fr_3(O)$

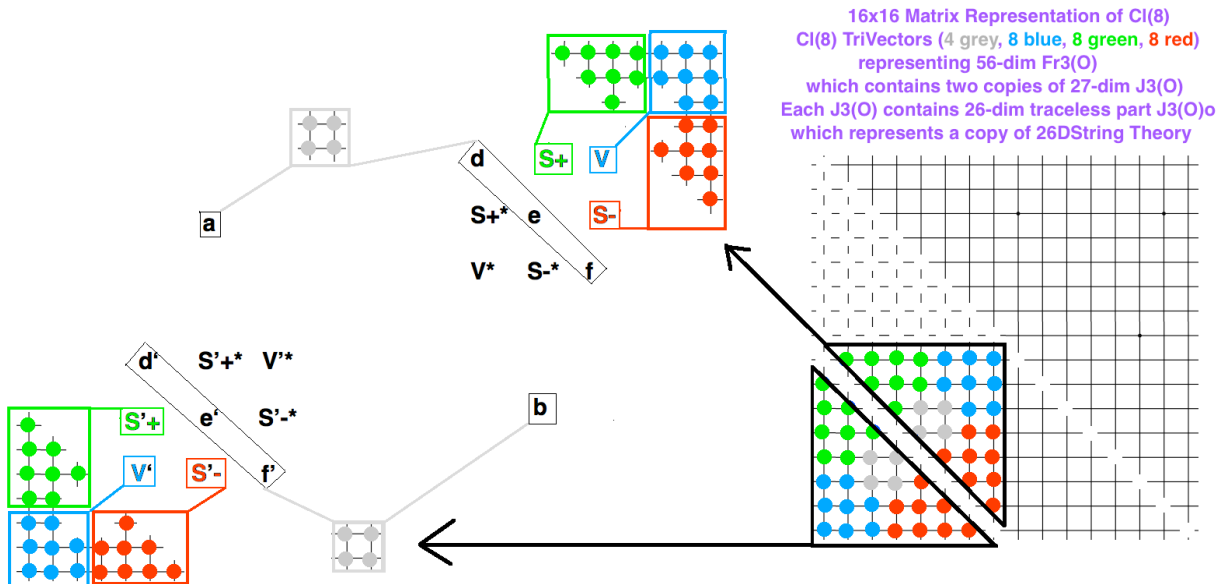

Here is the correspondence in terms of graded  $Cl(8)$ :

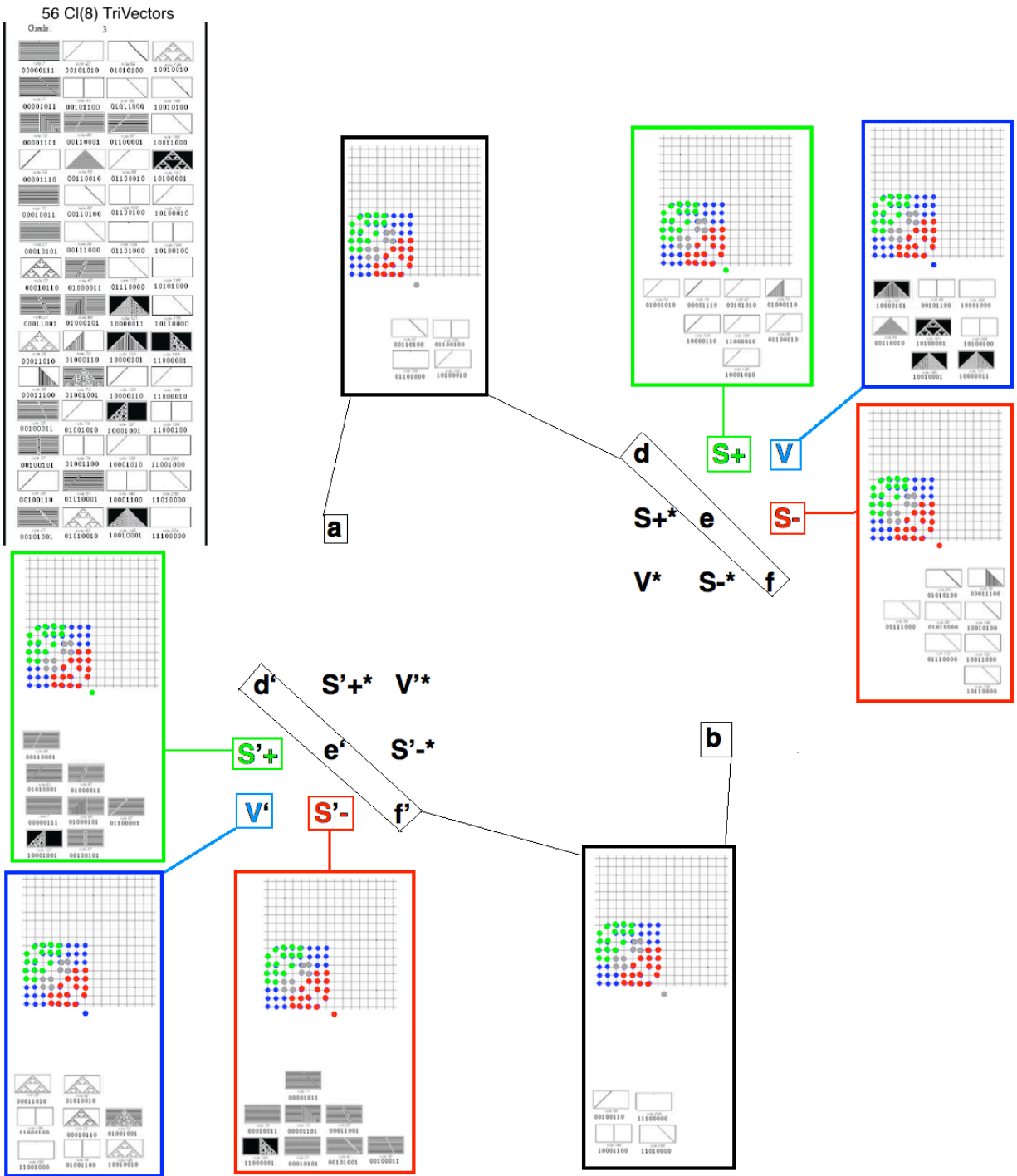

Due to 8-Periodicity of Real Clifford Algebras  
 tensor product  $Cl(8) \times Cl(8) = Cl(16)$

First Cl(8) D4 F4 acting on M4  
Graded Representation

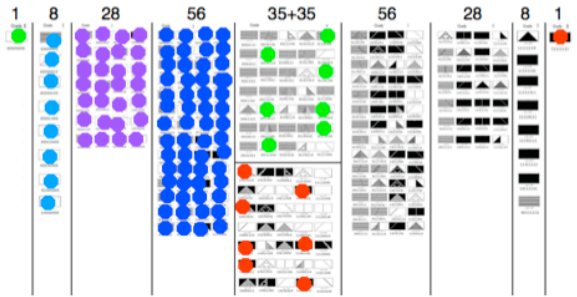

Second Cl(8) D4 F4 acting on CP2  
Graded Representation

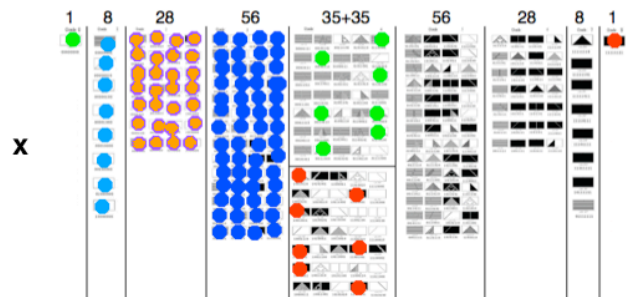

16x16 Matrix Representation

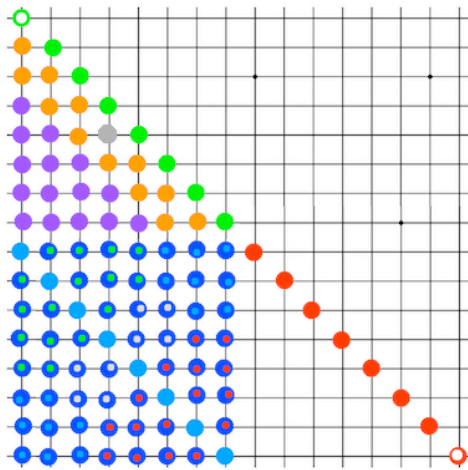

16x16 Matrix Representation

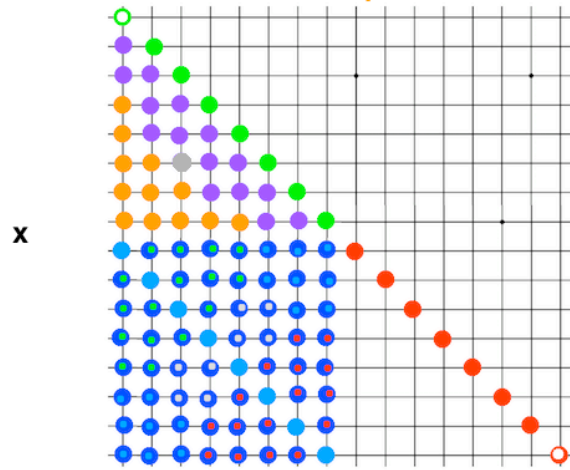

=

256x256 = 65,536-dim Cl(16) containing 248-dim E8  
1 16 120 560 ...

BiVector D8 of E8 = 120 = 28 + 8x8 + 28 = 28 + 64 + 28

TriVector Cl(16) String Theory = 560 = 56 + 8x28 + 28x8 + 56 = 10 x 56

Cl(16) Spinors = 8 x 8 + 8 x 8 + 8 x 8 + 8 x 8

E8 half-Spinors = 8 x 8 + 8 x 8 = 64 + 64

The 560 TriVectors of Cl(16) are 10 copies of 56 = Fr3(O)

Fr3(O) is Complexification of J3(O)

d	S+	V
S+*	e	S-
V*	S-*	f

V is a Superposition of 8 E8 8-dim Spacetime Lattices  
(7 being Integral Domains)

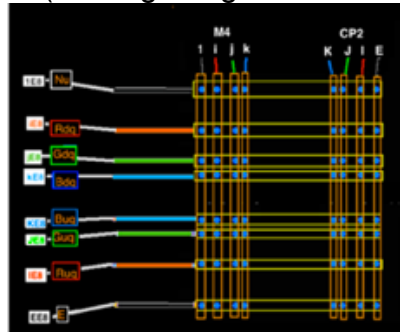

corresponding to the 8 fundamental Fermion Types.

Each Fermion Type propagates within its own E8 Lattice  
within the Superposition  
which accounts for 8 of the 10 copies of Fr3(O)

The other 2 copies of Fr3(O)  
correspond to the 2 diagonal elements d and f  
which describe the 10-dim R(1,9) space  
that is Conformal over 8-dim R(0,8) space  
which has Clifford Algebra  $Cl(0,8) = Cl(1,7)$  of  $RP^1 \times S^7$

The two copies of  $J3(O)_o$  within each  $Fr3(O)$  correspond to Real and Imaginary 26D String Theories where the Real Part represents the Shilov Boundary of the Bulk Complex Bounded Domain.

The Clifford Algebra of 26D String Theory is  $Cl(1,25)$   
 $Cl(1,25) = M(2, Cl(0,24)) =$   
 $= 2 \times 2$  matrices with entries in  $Cl(0,24) =$   
 $=$  Conformal Structure over  $Cl(0,24)$

$Cl(0,24) = Cl(0,8) \times Cl(0,16)$   
 $Cl(0,16)$  has 16-dim Barnes-Wall Lattice Structure  
 $Cl(0,8)$  has

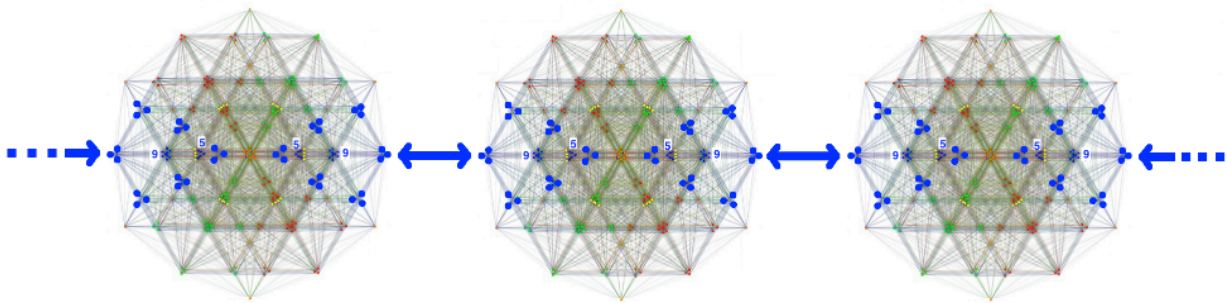

s 8-dim  $E_8$  Lattice Structure

so

$Cl(0,24)$  has 24-dim Leech Lattice Structure

and

$Cl(1,25) = M(2, Cl(0,24))$  has Lorentz Leech Lattice Structure  
with Monster Group Symmetry of each Lattice Cell

Since all matrix entries are  $Cl(0,24) =$  tensor product of 3 copies of  $Cl(0,8)$   
8-Periodicity allows formation of the tensor products of copies of  $Cl(1,25)$

One  $Cl(1,25)$  containing one  $Cl(0,16)$  containing one  $E_8$  gives a Lagrangian description of one local spacetime neighborhood.

To get a realistic global spacetime structure, take the tensor product  $Cl(1,25) \times \dots \times Cl(1,25)$  with all E8 local 8-dim Octonionic spacetimes consistently aligned as described by 64-dim D8 / D4xD4 (this visualization use hexagonal 2D projection of the 240 E8 root vectors)

Completion of the Union of all Tensor Products of the form

$$Cl(1,25) \times \dots (N \text{ times tensor product}) \dots \times Cl(1,25)$$

gives an Algebraic Quantum Field Theory (AQFT)

For  $N = 2^8 = 256$  the copies of  $Cl(1,25)$  are on the 256 vertices of the 8-dim HyperCube

For  $N = 2^{16} = 65,536 = 4^8$  the copies of  $Cl(1,25)$  fill in the 8-dim HyperCube as described by William Gilbert's web page: "... The n-bit reflected binary Gray code will describe a path on the edges of an n-dimensional cube that can be used as the initial stage of a Hilbert curve that will fill an n-dimensional cube. ...".

The vertices of the Hilbert curve are at the centers of the  $2^8$  sub-8-HyperCubes whose edge lengths are  $1/2$  of the edge lengths of the original 8-dim HyperCube

As N grows, the copies of  $Cl(1,25)$  continue to fill the 8-dim HyperCube of E8 SpaceTime using higher Hilbert curve stages from the 8-bit reflected binary Gray code subdividing the initial 8-dim HyperCube into more and



more sub-HyperCubes.

If edges of sub-HyperCubes, equal to the distance between adjacent copies of  $Cl(1,25)$ , remain constantly at the Planck Length, then the full 8-dim HyperCube of our Universe expands as  $N$  grows to  $2^{16}$  and beyond

similarly to the way shown by this 3-HyperCube example for  $N = 2^3, 4^3, 8^3$  from William Gilbert's web page:

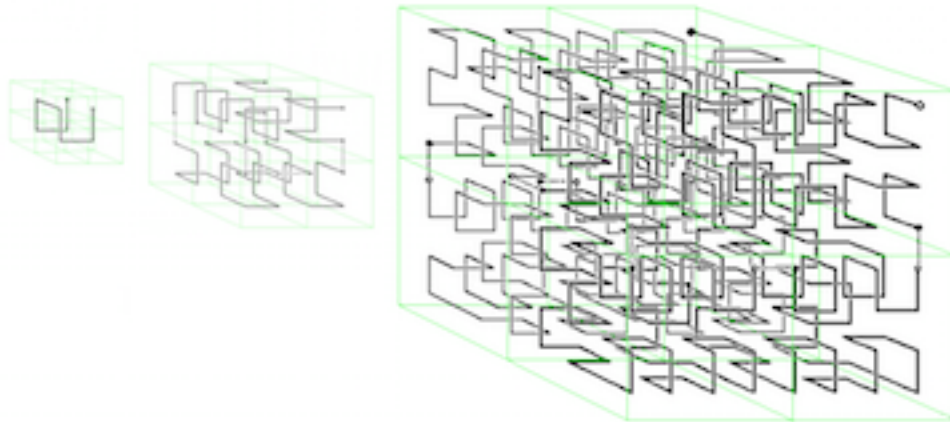

The Union of all  $Cl(1,25)$  tensor products is  
the Union of all subdivided 8-HyperCubes  
and  
their Completion is a huge superposition  
of 8-HyperCube Continuous Volumes  
which Completion belongs to the Third Grothendieck Universe  
and  
is an AQFT Real Clifford Algebra generalization of  
the Complex Clifford Algebra Fock Space  
Hyperfiniteness II1 von Neumann factor Algebra

The Third Grothendieck Universe AQFT contains within each  $Cl(1,25)$   
a realistic  $E_8$  Lagrangian within  $Cl(16)$   
( see viXra 1602.0319, 1701.0495, 1701.0496 )  
and  
contains  
10 copies of  $Fr_3(O)$  within 560 TriVectors of  $Cl(16)$   
to describe a World-Lines = Strings String Theory  
with structure of  $J_3(O)$  26D String Theory



### J3(O)o World-Line String Bohm Quantum Theory

A physically realistic Lattice Bosonic String Theory with Strings = World-Lines and Monster Group Symmetry containing gravity and the Standard Model can be constructed consistently with Cl(16) - E8 physics

In “Space-Time Code. III” Phys. Rev. D (1972) 2922-2931 David Finkelstein said “... According to relativity, the world is a collection of processes (events) with an unexpectedly unified causal or chronological structure. Then an object is secondary ... [to]... a long causal sequence of processes, **world line**. .. [if] we assemble these ... into chromosomelike code sequences ... and braid and cross-link these strands to make more complex objects and their interactions. ...[then]... The idea of the quantum jump comes into its own, and reigns supreme, even over space and time. ...”.

Andrew Gray in arXiv quant-ph/9712037 said:

“... probabilities are ... assigned to entire fine-grained histories ... base[d] ... on the Feynman path integral formulation ...

The formulation is fully relativistic and applicable to multi-particle systems.

It ... makes the same experimental predictions as quantum field theory ...”.

Luis E. Ibanez and Angel M. Uranga in “String Theory and Particle Physics” said:

“... String theory proposes ... small one-dimensional extended objects, strings, of typical size  $L_s = 1/M_s$ , with  $M_s$  known as the string scale ...

As a string evolves in time, it sweeps out a two-dimensional surface in spacetime, known as the worldsheet, which is the analog of the ... worldline of a point particle ... for the bosonic string theory ... the classical string action is the total area spanned by the worldsheet ... This is the ... Nambu– Goto action ...”.

**In my unconventional view**

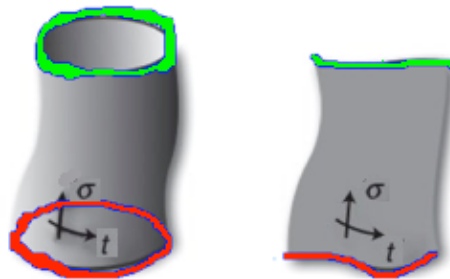

the red line and the green line are different strings/worldlines/histories and **the world-sheet is the minimal surface connecting them, carrying the Bohm Potential,**

**as Standard Model gauge bosons carry Force Potential between Point Particles.**

The t world-sheet coordinate is for Time of the string-world-line history.

The sigma world-sheet coordinate is for Bohm Potential Gauge Boson at a given Time.

( images adapted from “String Theory and Particle Physics” by Ibanez and Uranga )

Further, Ibanez and Uranga also said:

“... The string groundstate corresponds to a 26d spacetime tachyonic scalar field  $T(x)$ . This **tachyon** ... is ... unstable

...

The massless two-index tensor splits into irreducible representations of  $SO(24)$  ... Its **trace** corresponds to a scalar field, the **dilaton**  $\phi$ , whose vev fixes the string interaction coupling constant  $g_s$

...

the **antisymmetric** part is the 26d 2-form field  $BMN$

...

The **symmetric traceless** part is the 26d graviton  $GMN$  ...”.

Closed string **tachyons** localized at orbifolds of fermions produce virtual clouds of particles / antiparticles that dress fermions.

**Dilatons** are Goldstone bosons of spontaneously broken scale invariance that (analogous to Higgs) go from mediating a long-range scalar gravity-type force to the nonlocality of the Bohm-Sarfatti Quantum Potential.

The **antisymmetric**  $SO(24)$  little group is related to the Monster automorphism group that is the symmetry of each cell of Planck-scale local lattice structure.

Joe Polchinski in “String Theory, Volume 1, An Introduction to the Bosonic String” said: “... we find at  $m^2 = -4/\alpha'$  the tachyon, and at  $m^2 = 0$  the  $24 \times 24$  states of the graviton, dilaton, and antisymmetric tensor ...”.

**Must the  $24 \times 24$  symmetric matrices be interpreted as the graviton ? - !!! NO !!!**

The  $24 \times 24$  Real Symmetric Matrices form the Jordan Algebra  $J(24, \mathbb{R})$ .

Jordan algebras correspond to the matrix algebra of quantum mechanical states, that is, from a particle physics point of view, the configuration of particles in spacetime upon which the gauge groups act.

24-Real-dim space has a natural Octonionic structure of 3-Octonionic-dim space.

The corresponding Jordan Algebra is  $J(3, \mathbb{O}) = 3 \times 3$  Hermitian Octonion matrices.

Their 26-dim traceless part  $J(3, \mathbb{O})_0$  describes the 26-dim of Bosonic String Theory  
and  
the algebra of its Quantum States,  
so that

**the  $24 \times 24$  traceless symmetric spin-2 particle is the Quantum Bohmion.**

Joseph Polchinski, in his books String Theory vols. I and II( Cambridge 1998), says: "... the **closed ... unoriented ... bosonic string ... theory** has the maximal 26-dimensional Poincare invariance ... It is possible to have a consistent theory ...[with]... the **dilaton** ... the **[string-]graviton** ...[and]... the **tachyon** ...[whose]... negative mass-squared means that the no-string 'vacuum' is actually unstable ... "

The **dilaton** of E8 Physics sets the Planck scale as the scale for the 16 dimensions that are orbifolded fermion particles and anti-particles and the 4 dimensions of the CP2 Internal Symmetry Space of M4xCP2 spacetime. The remaining  $26-16-4 = 6$  dimensions are the Conformal Physical Spacetime with  $\text{Spin}(2,4) = \text{SU}(2,2)$  symmetry that produces M4 Physical Spacetime

**E8 Physics 26D String Theory Spacetime**  
**10D = 6D Conformal Spacetime + 4D Compact CP2 Internal Symmetry Space**  
**with CP2 = SU(3) / SU(2)xU(1) as unique Compactification**  
**which specifies Gauge Groups of the Standard Model.**

If Strings = World Lines and World Lines are past and future histories of particles, then **spin-2 string entities carry Bohm Quantum Potential** with Sarfatti Back-Reaction related to Cramer Transaction Quantum Theory.

Roger Penrose in "Road to Reality" (Knopf 2004) says: "... **quantum** mechanics ... alternates between ... **unitary** evolution **U** ... and state reduction **R** ... quantum state **reduction** ... is ... **objective** ... **OR** ... it is always a gravitational phenomenon ... [A] conscious event ... would be ... orchestrated **OR** ... of ... large-scale quantum coherence ... of ... microtubules ...".

**String-Gravity produces Sarfatti-Bohm Quantum Potential with Back-Reaction.**

It is distinct from the MacDowell-Mansouri Gravity of stars and planets.

The **tachyon** produces the instability of a truly empty vacuum state with no strings. It is natural, because if our Universe were ever to be in a state with no strings, then tachyons would create strings = World Lines thus filling our Universe with the particles and World-Lines = strings that we see. Something like this is necessary for particle creation in the Inflationary Era of non-unitary Octonionic processes.

Our construction of a 26D String Theory consistent with E8 Physics uses a structure that is not well-known, so I will mention it here before we start:

There are 7 independent E8 lattices, each corresponding to one of the 7 imaginary octonions denoted by  $iE8$ ,  $jE8$ ,  $kE8$ ,  $EE8$ ,  $IE8$ ,  $JE8$ , and  $KE8$  and related to both D8 adjoint and half-spinor parts of E8 and with 240 first-shell vertices. An 8th E8 lattice  $1E8$  with 240 first-shell vertices related to the D8 adjoint part of E8 is related to the 7 octonion imaginary lattices (viXra 1301.0150v2) .

It can act as an effectively independent lattice as part of the basis subsets  $\{1E8, EE8\}$  or  $\{1E8, iE8, jE8, kE8\}$ .

With that in mind, here is the construction:

Step 1:

Consider the 26 Dimensions of Bosonic String Theory as a 26-dimensional traceless part  $J_3(O)$  living inside a  $Fr_3(O)$

$$\begin{array}{ccc} a & O_+ & O_v \\ O_+^* & b & O_- \\ O_v^* & O_-^* & -a-b \end{array}$$

(where  $O_v$ ,  $O_+$ , and  $O_-$  are in Octonion space with basis  $\{1, i, j, k, E, I, J, K\}$  and  $a$  and  $b$  are real numbers with basis  $\{1\}$ ) of the 27-dimensional Jordan algebra  $J_3(O)$  of  $3 \times 3$  Hermitian Octonion matrices.

Step 2:

Take a 3-brane to correspond to the Imaginary Quaternionic associative subspace spanned by  $\{i, j, k\}$  in the 8-dimensional Octonionic  $O_v$  space.

Step 3:

Compactify the 4-dimensional co-associative subspace spanned by  $\{E, I, J, K\}$  in the Octonionic  $O_v$  space as a  $CP^2 = SU(3)/U(2)$ , with its 4 world-brane scalars corresponding to the 4 covariant components of a Higgs scalar. Add this subspace to the 3-brane, to get a 7-brane.

Step 4:

Orbifold the 1-dimensional Real subspace spanned by  $\{1\}$  in the Octonionic  $O_v$  space by the discrete multiplicative group  $Z_2 = \{-1, +1\}$ , with its fixed points  $\{-1, +1\}$  corresponding to past and future time. This discretizes time steps and gets rid of the world-brane scalar corresponding to the subspace spanned by  $\{1\}$  in  $O_v$ . It also gives our brane a 2-level timelike structure, so that its past can connect to the future of a preceding brane and its future can connect to the past of a succeeding brane. Add this subspace to the 7-brane, to get an 8-brane Spacetime Superposition. Our basic 8-brane looks like two layers (past and future) of 7-branes. Beyond the 8-brane our String Theory has  $26 - 8 = 18$  dimensions, of which  $25 - 8 = 17$  have corresponding world-brane scalars:

8 world-brane scalars for Octonionic  $O_+$  space;

8 world-brane scalars for Octonionic  $O_-$  space;

1 world-brane scalars for real  $a$  space;

and

1 dimension, for real  $b$  space, in which 8-branes containing spacelike 3-branes are stacked in timelike order.

Step 5:

To get rid of the world-brane scalars corresponding to the Octonionic  $O^+$  space, orbifold it by the 16-element discrete multiplicative group

$$\text{Oct}_{16} = \{+/-1, +/-i, +/-j, +/-k, +/-E, +/-I, +/-J, +/-K\}$$

to reduce  $O^+$  to 16 singular points  $\{-1, -i, -j, -k, -E, -I, -J, -K, +1, +i, +j, +k, +E, +I, +J, +K\}$ .

Let the 8  $O^+$  singular points  $\{-1, -i, -j, -k, -E, -I, -J, -K\}$  correspond to the fundamental fermion particles  
{neutrino, red up quark, green up quark, blue up quark,  
electron, red down quark, green down quark, blue down quark}  
located on the past 7-brane layer of the 8-brane.

Let the 8  $O^+$  singular points  $\{+1, +i, +j, +k, +E, +I, +J, +K\}$  correspond to the fundamental fermion particles  
{neutrino, red up quark, green up quark, blue up quark,  
electron, red down quark, green down quark, blue down quark}  
located on the future 7-brane layer of the 8-brane.

The 8 components of the 8 fundamental first-generation fermion particles =  $8 \times 8 = 64$  correspond to the 64 of the 128-dim half-spinor 8-brane part of  $E_8$ .

This gets rid of the 8 world-brane scalars corresponding to  $O^+$ , and leaves:

8 world-brane scalars for Octonionic  $O^-$  space;

1 world-brane scalars for real a space;

and

1 dimension, for real b space, in which 8-branes containing spacelike 3-branes are stacked in timelike order.

Step 6:

To get rid of the world-brane scalars corresponding to the Octonionic  $O^-$  space, orbifold it by the 16-element discrete multiplicative group

$$\text{Oct}_{16} = \{+/-1, +/-i, +/-j, +/-k, +/-E, +/-I, +/-J, +/-K\}$$

to reduce  $O^-$  to 16 singular points  $\{-1, -i, -j, -k, -E, -I, -J, -K, +1, +i, +j, +k, +E, +I, +J, +K\}$ .

Let the 8  $O^-$  singular points  $\{-1, -i, -j, -k, -E, -I, -J, -K\}$  correspond to the fundamental fermion anti-particles {anti-neutrino, red up anti-quark, green up anti-quark, blue up anti-quark,  
positron, red down anti-quark, green down anti-quark, blue down anti-quark}  
located on the past 7-brane layer of  $D_8$ .

Let the 8  $O^-$  singular points  $\{+1, +i, +j, +k, +E, +I, +J, +K\}$  correspond to the fundamental fermion anti-particles {anti-neutrino, red up anti-quark, green up anti-quark, blue up anti-quark,  
positron, red down anti-quark, green down anti-quark, blue down anti-quark}  
located on the future 7-brane layer of the 8-brane.

The 8 components of 8 fundamental first-generation fermion anti-particles =  $8 \times 8 = 64$  correspond to the 64 of the 128-dim half-spinor 8-brane part of  $E_8$ .

This gets rid of the 8 world-brane scalars corresponding to  $O^-$ , and leaves:

1 world-brane scalars for real a space;  
and  
1 dimension, for real b space, in which 8-branes containing spacelike 3-branes are stacked in timelike order.

Step 7:

Let the 1 world-brane scalar for real a space correspond to a Bohm-type Quantum Potential acting on strings in the stack of 8-branes.

Interpret strings as world-lines in the Many-Worlds, short strings representing virtual particles and loops.

Step 8:

Fundamentally, physics is described on HyperDiamond Lattice structures.

There are 7 independent E8 lattice Integral Domains, each corresponding to one of the 7 imaginary octonions. denoted by  $iE8$ ,  $jE8$ ,  $kE8$ ,  $EE8$ ,  $IE8$ ,  $JE8$ , and  $KE8$  and related to 8-brane adjoint and half-spinor parts of E8 and with 240 first-shell vertices.

An 8th 8-dim lattice  $1E8$  (not an Integral Domain) with 240 first-shell vertices related to the E8 adjoint part of E8 is related to the 7 octonion imaginary lattices.

Give each 8-brane structure based on Planck-scale E8 lattices so that each 8-brane is a superposition/intersection/coincidence of the eight E8 lattices.

( see viXra 1301.0150 )

Step 9:

Since Polchinski says "... If  $r$  D-branes coincide ... there are  $r^2$  vectors, forming the adjoint of a  $U(r)$  gauge group ...", make the following assignments:

a gauge boson emanating from the 8-brane from its  $1E8$  and  $EE8$  lattices is an  $SU(2) \times U(1)$  ElectroWeak boson accounting for the photon and  $W+$ ,  $W-$  and  $Z0$  bosons.

a gauge boson emanating from the 8-brane from its  $IE8$ ,  $JE8$ , and  $KE8$  lattices is a  $SU(3)$  Color Gluon boson thus accounting for the 8 Color Force Gluon bosons.

The  $4+8 = 12$  bosons of the Standard Model Electroweak and Color forces correspond to 12 of the 28 dimensions of 28-dim  $Spin(8)$

that corresponds to one of the 28 of the 120-dim adjoint 8-brane parts of E8.

a gauge boson emanating from the 8-brane from its  $1E8$ ,  $iE8$ ,  $jE8$ , and  $kE8$  lattices is a  $U(2,2)$  boson for conformal  $U(2,2) = Spin(2,4) \times U(1)$  MacDowell-Mansouri gravity plus conformal structures consistent with the Higgs mechanism and with observed Dark Energy, Dark Matter, and Ordinary matter.

The 16-dim  $U(2,2)$  is a subgroup of 28-dim  $Spin(2,6)$

that corresponds to the other 28 of the 120-dim adjoint 8-brane part of E8.

Step 10:  
Since Polchinski says

"... there will also be  $r^2$  massless scalars from the components normal to the D-brane. ... the collective coordinates ...  $X^u$  ... for the embedding of  $n$  D-branes in spacetime are now enlarged to  $n \times n$  matrices.

This 'noncommutative geometry' ...[may be]... an important hint about the nature of spacetime. ...",

make the following assignment:

The  $8 \times 8$  matrices for the collective coordinates linking aa 8-brane to the next 8-brane in the stack are needed to connect the eight  $E_8$  lattices of the 8-brane to the eight  $E_8$  lattices of the next 8-brane in the stack.

The  $8 \times 8 = 64$  correspond to the 64 of the 120 adjoint 8-brane part of  $E_8$ .

We have now accounted for all the scalars  
and  
have shown that the model has the physics content of the realistic  $E_8$  Physics model with Lagrangian structure based on  $E_8 = (28 + 28 + 64) + (64 + 64)$   
and  
AQFT structure based on  $Cl(1,25)$  with real Clifford Algebra periodicity and generalized Hyperfinite II<sub>1</sub> von Neumann factor algebra.

In my unconventional view

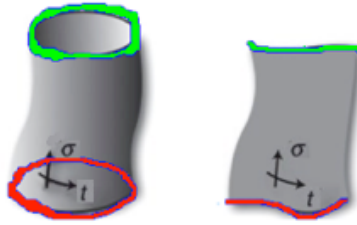

**the red line and the green line  
are different strings/worldlines/histories and  
the world-sheet is the minimal surface connecting them,  
carrying the Bohm Potential,  
The t world-sheet coordinate is for Time  
The sigma world-sheet coordinate is  
for Bohm Potential Gauge Boson at a given Time.**

Joe Polchinski in “String Theory, Volume 1, An Introduction to the Bosonic String” said:  
“... we find at  $m^2 = -4 / \alpha'$  the tachyon, and  
at  $m^2 = 0$  the 24 x 24 states of the graviton, dilaton, and antisymmetric tensor ...”.

Ibanez and Uranga said:

**“... This tachyon ... is ... unstable ...  
the antisymmetric part is the 26d 2-form field BMN ...  
The symmetric traceless part is the 26d graviton GMN ...  
Its trace corresponds to a scalar field, the dilaton  $\phi$  ...”.**



**Tachyons localized at orbifolds of fermions  
produce virtual clouds  
of particles / antiparticles that dress fermions.**

**The antisymmetric  $SO(24)$  little group is related to  
the Monster automorphism group that is  
the symmetry of each cell of Planck-scale local lattice structure.**

**In  $E_8$  Physics,  
the String Theory graviton is NOT a graviton  
but is the Quantum Bohmion.**

**The  $24 \times 24$  Real Symmetric Matrices form the Jordan Algebra  $J(24, \mathbb{R})$ .  
 $24$ -Real-dim space has a natural Octonionic structure.**

**The corresponding Jordan Algebra is  
 $J(3, \mathbb{O}) = 3 \times 3$  Hermitian Octonion matrices.**

**Their  $26$ -dim traceless part  $J(3, \mathbb{O})_0$   
describes the  $26$ -dim of Bosonic String Theory  
and the algebra of its Quantum States, so that  
the  $24 \times 24$  traceless symmetric spin-2 particle  
is the Quantum Bohmion.**

**Dilatons are  
Goldstone bosons of spontaneously broken scale invariance  
that  
(analogous to Higgs) go from mediating a long-range scalar force  
to the nonlocality of the Bohm-Sarfatti Quantum Potential.**

## Lagrangian for Bohm Quantum Potential

**Sarfatti-Bohm Quantum Potential emerges from 26D E8 World-Line String Theory so is treated separately from the Local Classical E8 Lagrangian in 8D (or in 4D) describing the Standard Model and Gravity+Dark Energy plus Propagator Phase.**

**Roderick Sutherland (arXiv 1509.02442) gave a Lagrangian for the Bohm Potential** saying: "... This paper focuses on interpretations of QM in which the underlying reality is taken to consist of particles have definite trajectories at all times ... An example ... is the Bohm model ... This paper ... provid[es]... a Lagrangian ...[for]... the unfolding events ... ... describing more than one particle while maintaining a relativistic description requires the introduction of final boundary conditions as well as initial, thereby entailing retrocausality ...

In addition ... the Lagrangian approach pursued here to describe particle trajectories also entails the natural inclusion of an accompanying field to influence the particle's motion away from classical mechanics and reproduce the correct quantum predictions. In so doing, it is ... providing a physical explanation for why quantum phenomena exist at all ... **the particle is seen to be**

**the source of a field which alters the particle's trajectory via self-interaction ...**

The Dirac case ... each particle in an entangled many-particle state will be described by an individual Lagrangian density ... of the form:

$$\mathcal{L} = \text{Re} \left[ \frac{1}{\langle f|i \rangle} \left( -i\bar{\Psi}_f \gamma^\alpha \partial_\alpha \Psi_i + m\bar{\Psi}_f \Psi_i \right) \right] \mp \sigma_0 \rho_0 |u_\alpha u^\alpha|^{\frac{1}{2}} + \sigma_0 u_\alpha j^\alpha$$

... the ...[first]... term ...[is]... the ... Lagrangian densities for the PSI field alone ...

... sigma\_o is the rest density distribution of the particle through space ... j is the current density ...

... rho\_o and u are the rest density and 4-velocity of the probability flow ...".

**Jack Sarfatti extended the Sutherland Lagrangian to include Back-Reaction**

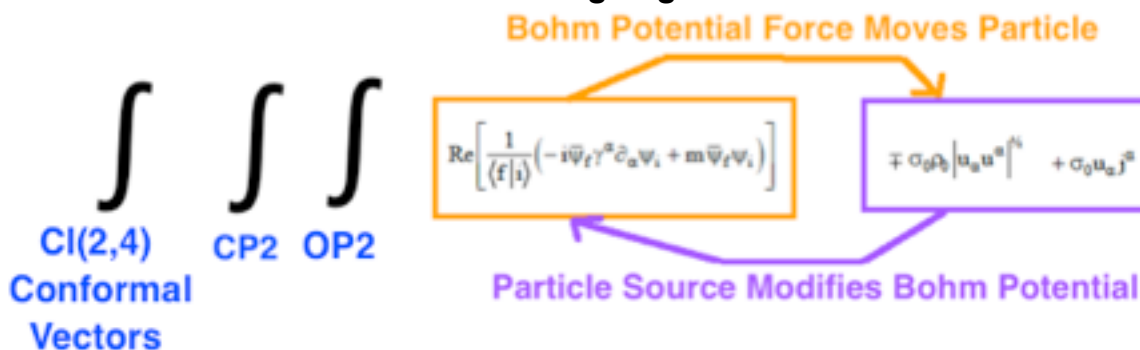

where a, b and VM4 form CI(2,4) vectors and VCP2 forms CP2 and S+ and S- form OP2 so that

26D = 16D orbifolded fermions + 10D and 10D = 6D Conformal Space + 4D CP2 ISS (ISS = Internal Symmetry Space and 6D Conformal contains 4D M4 of Kaluza-Klein M4xCP2)

saying (linkedin.com Pulse 13 January 2016): "... the reason entanglement cannot be

used as a direct messaging channel between subsystems of an entangled complex quantum system, is the lack of direct back-reaction of the classical particles and classical local gauge fields on their shared entangled Bohmian quantum information pilot wave ... Roderick. I. Sutherland ... using Lagrangian field theory, shows how to make the original 1952 Bohm pilot-wave theory completely relativistic, and how to avoid the need for configuration space for many-particle entanglement.

**The trick is that final boundary conditions on the action as well as initial boundary conditions influence what happens in the present.**

The general theory is "post-quantum" ... and it is non-statistical ... There is complete two-way action-reaction between quantum pilot waves and the classical particles and classical local gauge fields ... orthodox statistical quantum theory, with no-signaling ...[is derived]... in two steps,

first arbitrarily set the back-reaction (of particles and classical gauge field on their pilot waves) to zero. This is analogous to setting the curvature equal to zero in general relativity, or more precisely in setting  $G$  to zero.

Second, integrate out the final boundary information, thereby adding the statistical Born rule to the mix. ...

the mathematical condition for zero post-quantum back-reaction of particles and classical fields (aka "beables" J.S. Bell's term) is exactly de Broglie's guidance constraint. That is, in the simplest case, the classical particle velocity is proportional to the gradient of the phase of the quantum pilot wave. It is for this reason, that the independent existence of the classical beables can be ignored in most quantum calculations.

However, orthodox quantum theory assumes that the quantum system is thermodynamically closed between strong von Neumann projection measurements that obey the Born probability rule.

**The new post-quantum theory in the equations of Sutherland, prior to taking the limit of orthodox quantum theory, should apply to pumped open dissipative structures.** Living matter is the prime example. ...". Jack Sarfatti (email 31 January 2016) said:  
"... **post-quantum theory with action-reaction between quantum information pilot wave and its be-able is compatible with free will. ...**".

## Sarfatti-Bohm-Penrose-Hameroff Quantum Consciousness

In "Space-Time Code. III" Phys. Rev. D (1972) 2922-2931 David Finkelstein said  
 "... **The primitive quantum processes or chronons of which world lines are made can be thought of as acts of emission or creation, Their duals, antichronons, represent acts of absorption or annihilation. ...**".

**The Creation-Annihilation Operator structure of the Bohm Quantum Potential of 26D String Theory** is given by the

Maximal Contraction of E8 = semidirect product A7 x h92  
 where h92 = 92+1+92 = 185-dim Heisenberg algebra and A7 = 63-dim SL(8)

The Maximal E8 Contraction A7 x h92 can be written as a 5-Graded Lie Algebra

$$28 + 64 + (\text{SL}(8, \mathbb{R}) + 1) + 64 + 28$$

Central Even Grade 0 = SL(8,R) + 1

The 1 is a scalar and SL(8,R) = Spin(8) + Traceless Symmetric 8x8 Matrices,  
 so SL(8,R) represents a local 8-dim SpaceTime in Polar Coordinates.

$$\text{Odd Grades } -1 \text{ and } +1 = 64 + 64$$

Each = 64 = 8x8 = Creation/Annihilation Operators for 8 components of 8 Fundamental Fermions.

$$\text{Even Grades } -2 \text{ and } +2 = 28 + 28$$

Each = Creation/Annihilation Operators for 28 Gauge Bosons of Gravity + Standard Model.

The 8x8 matrices linking one D8 to the next D8 of a World-Line String  
 give  $A7 \times R = U(8)$

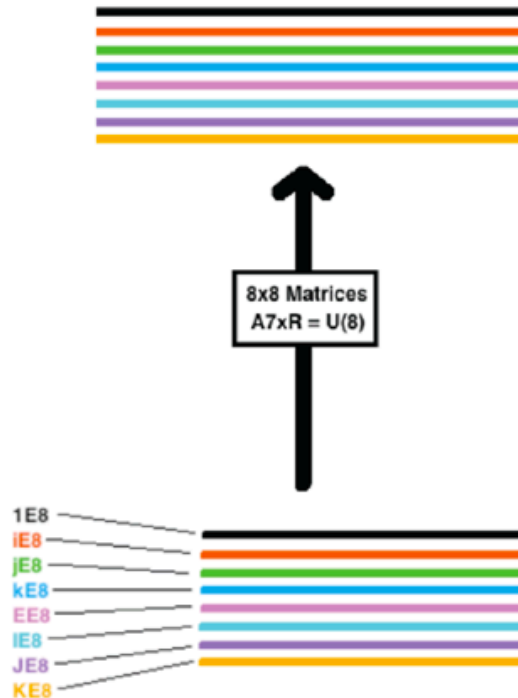

## 26D String Theory Structure is

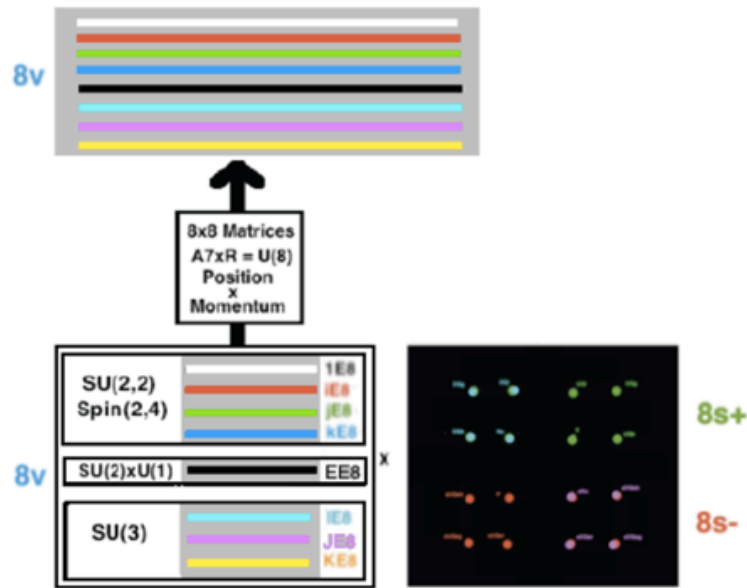

Green, Schwartz, and Witten, in "Superstring Theory" vol. 1, describe 26D String Theory saying "... The first excited level ... consists of ...

the ground state ... **tachyon** ...

and ... a scalar ... '**dilaton**' ...

and ... **SO(24)** ... **little group of a ...[26-dim]... massless particle** ...

and ... a ... **massless ... spin two state** ...".

Tachyons localized at orbifolds of fermions produce virtual clouds of particles / antiparticles that dress fermions by filling their Schwinger Source regions.

Dilatons are Goldstone bosons of spontaneously broken scale invariance that (analogous to Higgs) go from mediating a long-range scalar gravity-type force to the nonlocality of the Bohm-Sarfatti Quantum Potential.

The SO(24) little group is related to the Monster automorphism group that is the symmetry of each cell of Planck-scale local lattice structure.

**The massless spin 2 state = Bohmion = Carrier of the Bohm Force of the Bohm Quantum Potential.**

**Similarity of the spin 2 Bohmion to the spin 2 Graviton accounts for the Bohmion's ability to support Penrose Consciousness with Superposition Separation Energy Difference  $G m^2 / a$**

where, for a Human Brain,  $m$  = mass of electron and  $a$  = 1 nanometer in Tubulin Dimer

**"... Bohm's Quantum Potential can be viewed as an internal energy of a quantum system ..."**

according to Dennis, de Gosson, and Hiley ( arXiv 1412.5133 )

and

## **Bohm Quantum Potential inherits Sarfatti Back-Reaction from its spin-2 structure similar to General Relativity**

Peter R. Holland says in "The Quantum Theory of Motion" (Cambridge 1993):

"... the total force ... from the quantum potential ... does not ... fall off with distance ... because ... the quantum potential ... depends on the form of ...[the quantum state]... rather than ... its ... magnitude ...".

### **Penrose-Hameroff-type Quantum Consciousness is due to Resonant Quantum Potential Connections among Quantum State Forms.**

The Quantum State Form of a Conscious Brain is determined by the configuration of a subset of its  $10^{18}$  to  $10^{19}$  Tubulin Dimers described by a large Real Clifford Algebra. Paola Zizzi in gr-qc/0007006 describes the Octonionic Inflation Era of Our Universe as a Quantum Consciousness Superposition of States ending with Self-Decoherence after 64 doublings of Octonionic Inflation, at which time Our Universe is "... a superposed state of quantum ... [ qubits ].

the self-reduction of the superposed quantum state is ... reached at the end of inflation ...[at]... the decoherence time ... [  $T_{\text{decoh}} = 10^9 T_{\text{planck}} = 10^{(-34)}$  sec ] ... and corresponds to a superposed state of ... [  $10^{19} = 2^{64}$  qubits ]. ...".

64 doublings to  $2^{64}$  qubits corresponds to the Clifford algebra

$$Cl(64) = Cl(8 \times 8) = Cl(8) \times Cl(8) \times Cl(8) \times Cl(8) \times Cl(8) \times Cl(8) \times Cl(8) \times Cl(8)$$

By the periodicity-8 theorem of Real Clifford algebras,  $Cl(64)$  is the smallest Real Clifford algebra for which we can reflexively identify each component  $Cl(8)$  with a basis vector in the  $Cl(8)$  vector space.

This reflexive identification causes our universe to decohere at  $N = 2^{64} = 10^{19}$ . Octonionic Quantum Processes are Not Unitary and so can produce Fermions.

(see Stephen Adler's book "Quaternionic Quantum Mechanics ..." at pages 50-52 and 561).

At the end of 64 Unfoldings, Non-Unitary Octonionic Inflation ended having produced about  $(1/2) 16^{64} = (1/2) (2^4)^{64} = 2^{255} = 6 \times 10^{76}$  Fermions.

At the End of Inflation Our Universe had Temperature / Energy  $10^{27}$  K =  $10^{14}$  GeV so each of the  $10^{77}$  Fermions had energy of  $10^{14}$  GeV and collisions among them would for each of the  $10^{77}$  Fermions produce jets containing about  $10^{12}$  particles of energy 100 GeV or so so that the total number created by Inflation was about  $10^{89}$ .

The End of Inflation time was at about  $10^{(-34)}$  sec =  $2^{64} T_{\text{planck}}$  and

the size of our Universe was then about  $10^{(-24)}$  cm

which is about the size of a Fermion Schwinger Source Kerr-Newman Cloud.

The  $2^{64}$  qubits created by Inflation is roughly  $10^{19}$  which is roughly the number of Quantum Consciousness Tubulins in the Human Brain.

Therefore

**the Human Brain Quantum Consciousness has evolved in Our Universe  
to be roughly equivalent  
to the Maximum Consciousness of Our Inflationary Era Universe.**

Further,

each cell of E8 Lagrangian Spacetime corresponds to 65,536-dim  $Cl(16)$

which contains 248-dim E8 = 120-dim D8 bivectors +128-dim D8 half-spinors  
 Human Brain Microtubules 40 microns long have 65,536 Tubulin Dimers

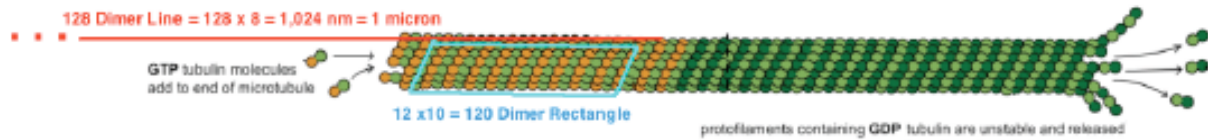

( image adapted from 12biophys.blogspot.com Lecture 11 )

and so

can have Bohm Quantum Resonance with Cl(16) Spacetime cells

so that **at any and all Times**

**the State of Consciousness of a Human is in exact resonant correspondence with a subset of the cells of E8 Classical Lagrangian Spacetime**

Therefore

**E8 Lagrangian Spacetime (as a Nambu-Jona-Lasinio Condensate)  
 is effectively the Spirit World**

**in which the Human States of Consciousness = Souls exist.**

After the death of the Human Physical Body the Spirit World interactions with its Soul are no longer constrained by Physical World interactions with its Body so that the Spirit World can harmonize the individual Soul with the collective Universal Soul.

**A Single Cell of E8 26-dimensional Bosonic String Theory,  
 in which Strings are physically interpreted as World-Lines,  
 can be described by taking the quotient of its 24-dimensional O+, O-, Ov  
 subspace modulo the 24-dimensional Leech lattice.**

**Its automorphism group is the largest finite sporadic group, the Monster Group,  
 whose order is**

$$8080, 17424, 79451, 28758, 86459, 90496, 17107, 57005, 75436, 80000, 00000$$

$$=$$

$$2^{46} \cdot 3^{20} \cdot 5^9 \cdot 7^6 \cdot 11^2 \cdot 13^3 \cdot 17 \cdot 19 \cdot 23 \cdot 29 \cdot 31 \cdot 41 \cdot 47 \cdot 59 \cdot 71$$

**or about  $8 \times 10^{53}$ .**

“... **Bohm’s Quantum Potential can be viewed as an internal energy** of a quantum system ...” according to Dennis, de Gosson, and Hiley ( arXiv 1412.5133 ) and Peter R. Holland says in "The Quantum Theory of Motion" (Cambridge 1993): "... **the total force ... from the quantum potential ... does not ... fall off with distance ...** because ... the quantum potential ... depends on the form of ...[the quantum state]... rather than ... its ... magnitude ...".

**Penrose-Hameroff-type Quantum Consciousness is due  
 to Resonant Quantum Potential Connections among Quantum State Forms.**

The Quantum State Form of a Conscious Brain is determined by the configuration of a subset of its  $10^{18}$  to  $10^{19}$  Tubulin Dimers with math description in terms of a large Real Clifford Algebra:

Resonance is discussed by Carver Mead in "Collective Electrodynamics" ( MIT 2000 ):  
"... we can build ... a resonator from ... electric dipole ... configuration[s] ...



[ such as Tubulin Dimers ]

Because there are charges at the two ends of the dipole, we can have a contribution to the electric coupling from the scalar potential ... as well [as] from the magnetic coupling ... from the vector potential ... electric dipole coupling is stronger than magnetic dipole coupling ... the coupling of ... two ... configurations ... is the same, whether retarded or advanced potentials are used. Any ... configuration ... couples to any other on its light cone, whether past or future. ... The total phase accumulation in a ... configuration ... is the sum of that due to its own current, and that due to currents in other ... configurations ... far away ...

The energy in a single resonator alternates between the kinetic energy of the electrons (inductance), and the potential energy of the electrons (capacitance). With the two resonators coupled, the energy shifts back and forth between the two resonators in such a way that the total energy is constant ... The conservation of energy holds despite an arbitrary separation between the resonators ... Instead of scaling linearly with the number of charges that take part in the motion, the momentum of a collective system scales as the square of the number of charges! ... The inertia of a collective system, however, is a manifestation of the interaction, and cannot be assigned to the elements separately. ... Thus, it is clear that collective quantum systems do not have a classical correspondence limit. ...".



For the  $10^{18}$  Tubulin Dimers of the human brain,  
the resonant frequencies are the same and exchanges of energy among them  
act to keep them **locked in a Quantum Protectorate collective coherent state**.

Philip W. Anderson in cond-mat/0007287 and cond-mat/007185 said:

"... Laughlin and Pines have introduced the term "Quantum protectorate" as a general descriptor of the fact that certain states of quantum many-body systems exhibit properties which are unaffected by imperfections, impurities and thermal fluctuations. They instance ... flux quantization in superconductors, equivalent to the Josephson frequency relation which again has mensuration accuracy and is independent of imperfections and scattering. ...

... the source of quantum protection is a collective state of the quantum field involved such that the individual particles are sufficiently tightly coupled that elementary excitations no longer involve a few particles but are collective excitations of the whole system, and therefore, macroscopic behavior is mostly determined by overall conservation laws ... **a "quantum protectorate" ... [ is ]... a state in which the many-body correlations are so strong that the dynamics can no longer be described in terms of individual particles, and therefore perturbations which scatter individual particles are not effective ...**"

Mershin, Sanabria, Miller, Nawarathna, Skoulakis, Mavromatos, Kolomenskii, Scheussler, Ludena, and Nanopoulos in physics/0505080 "Towards Experimental Tests of Quantum Effects in Cytoskeletal Proteins" said:



Classically, the various dimers can only be in the ...[ those ]... conformations. Each dimer is influenced by the neighboring dimers resulting in the possibility of a transition. This is the basis for classical information processing, which constitutes the picture of a (classical) cellular automaton.

If we assume ... that each dimer can find itself in a QM superposition of ...[ those ]... states, a quantum nature results. Tubulin can then be viewed as a typical two-state quantum mechanical system, where the dimers couple to conformational changes with  $10^{(-9)} - 10^{(-11)}$  sec transitions, corresponding to an angular frequency  $\sim 10^{10} - 10^{12}$  Hz. In this approximation, the upper bound of this frequency range is assumed to represent (in order of magnitude) the characteristic frequency of the dimers, viewed as a two-state quantum-mechanical system ...[

The Energy Gap of our Universe as superconductor condensate spacetime is from  $3 \times 10^{(-18)}$  Hz (radius of universe) to  $3 \times 10^{43}$  Hz (Planck length). Its RMS amplitude is  $10^{13}$  Hz = 10 THz = energy of neutrino masses = critical temperature  $T_c$  of BSCCO superconducting crystal Josephson Junctions ]... large-scale quantum coherence ...[ has been observed ]... at temperatures within a factor of three of biological temperatures. MRI magnets contain hundreds of miles of superconducting wire and routinely carry a persistent current. There is no distance limit - the macroscopic wave function of the superfluid condensate of electron pairs, or Cooper pairs, in a sufficiently long cable could maintain its quantum phase coherence for many thousands of miles ... there is no limit to the total mass of the electrons participating in the superfluid state. The condensate is "protected" from thermal fluctuations by the BCS energy gap at the Fermi surface ... The term "quantum protectorate" ... describe[s] this and related many-body systems ...".

The Human Brain has about  $10^{11}$  Neuron cells, each about 1,000 nm in size.  
 The cytoskeleton of cells, including neurons of the brain, is made up of Microtubules

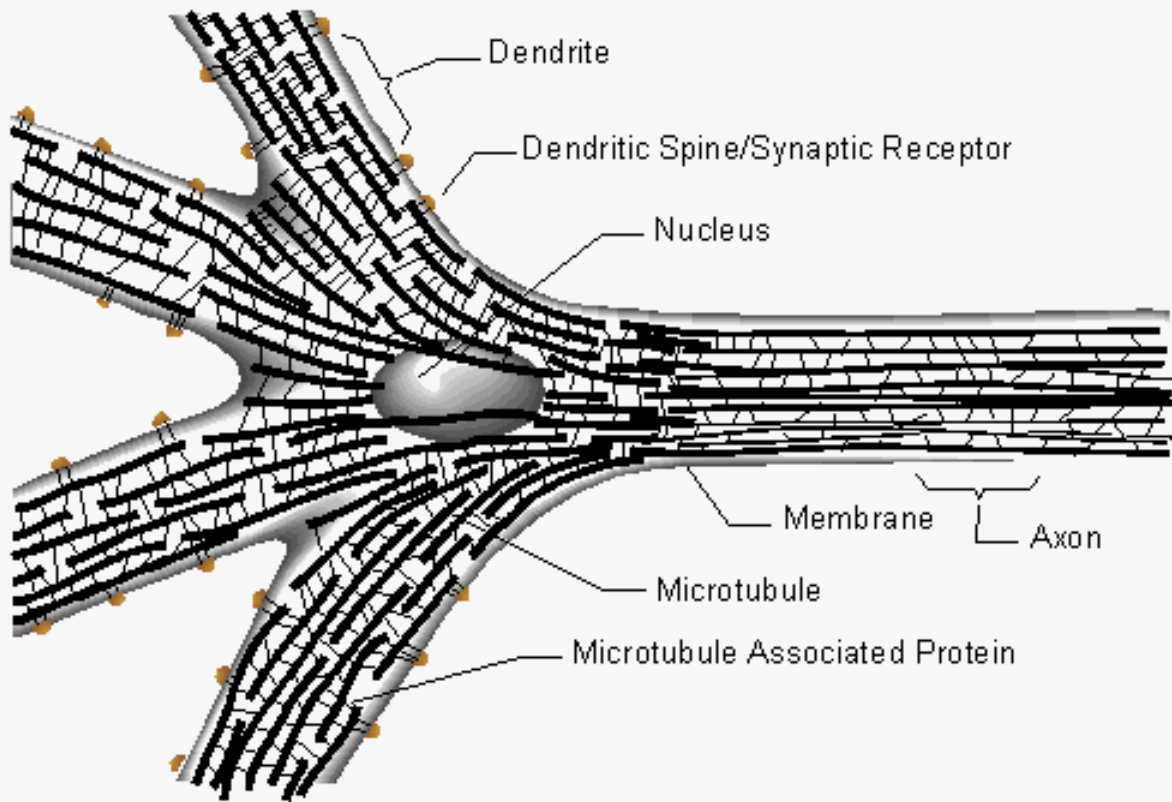

( image from "Orchestrated Objective Reduction of Quantum Coherence in Brain Microtubules: The "Orch OR" Model for Consciousness" by Penrose and Hameroff )

Each Neuron contains about  $10^9$  Tubulin Dimers, organized into Microtubules some of which are organized by a Centrosome. Centrosomes contain a pair of Centrioles.

A Centriole is about 200 nm wide and 400 nm long. Its wall is made up of 9 groups of 3 Microtubules, reflecting the symmetry of 27-dim  $J(3,0)$

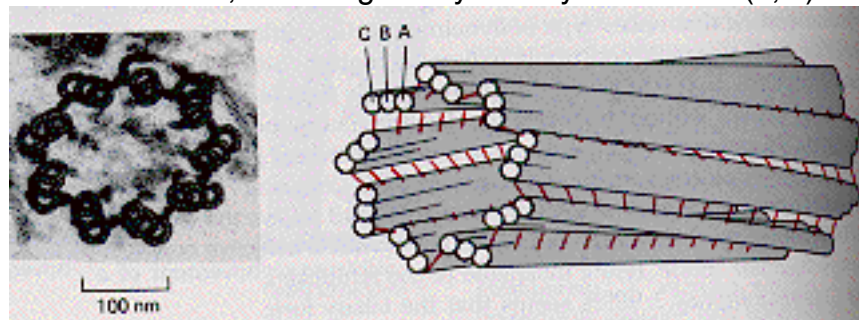

Each Microtubule is a hollow cylindrical tube with about 25 nm outside diameter and 14 nm inside diameter, made up of 13 columns of Tubulin Dimers

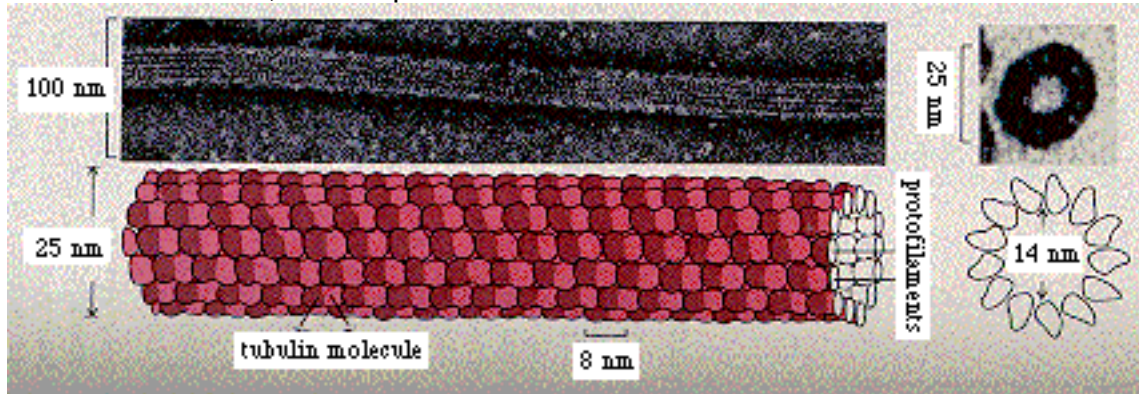

( illustrations and information about cells, microtubules, and centrioles are from Molecular Biology of the Cell, 2nd ed, by Alberts, Bray, Lewis, Raff, Roberts, and Watson (Garland 1989) )

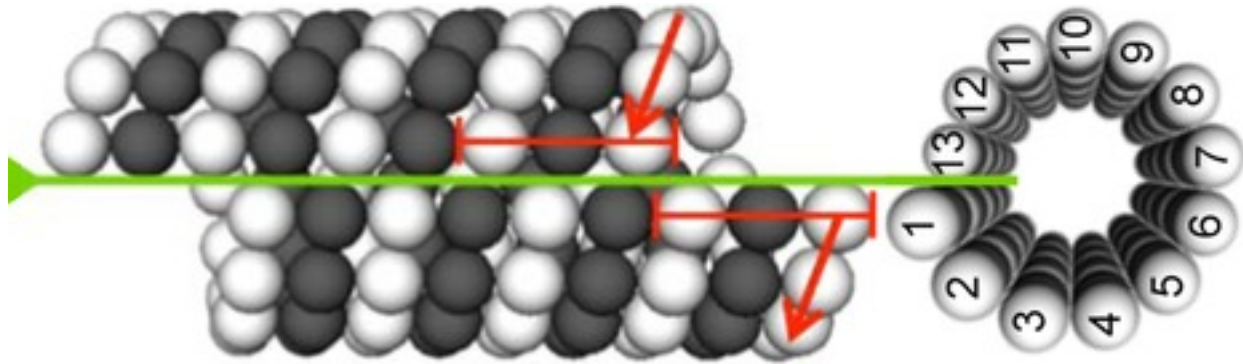

( image from Wikipedia on Microtubule )

Each Tubulin Dimer is about 8 nm x 4 nm x 4 nm, consists of two parts, alpha-tubulin and beta-tubulin ( each made up of about 450 Amino Acids, each containing roughly 20 Atoms )  
 A Microtubule 40 microns = 40,000 nm long contains  $13 \times 40,000 / 8 = 65,000$  Dimers



( images adapted from nonlocal.com/hbar/microtubules.html by Rhett Savage )

The black dots indicate the position of the Conformation Electrons.

There are two energetically distinct configurations for the Tubulin Dimers:

Conformation Electrons Similarly Aligned (left image) - State 0

Conformation Electrons Maximally Separated (right image) - State 1

The two structures - State 0 ground state and State 1 higher energy state - make Tubulin Dimers the basis for a Microtubule binary math / code system.

Microtubule binary math / code system corresponds to Clifford Algebras  $Cl(8)$  and  $Cl(8) \times Cl(8) = Cl(16)$  containing  $E_8$

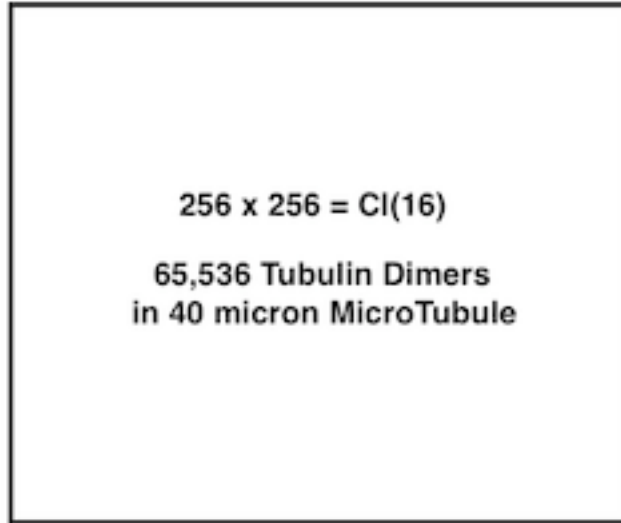

A 40 micron Microtubule contains Dimers representing the 65,536 elements of  $Cl(16)$  which contains the 248 elements of Lie Algebra  $E_8$  that defines  $E_8$  Physics Lagrangian.

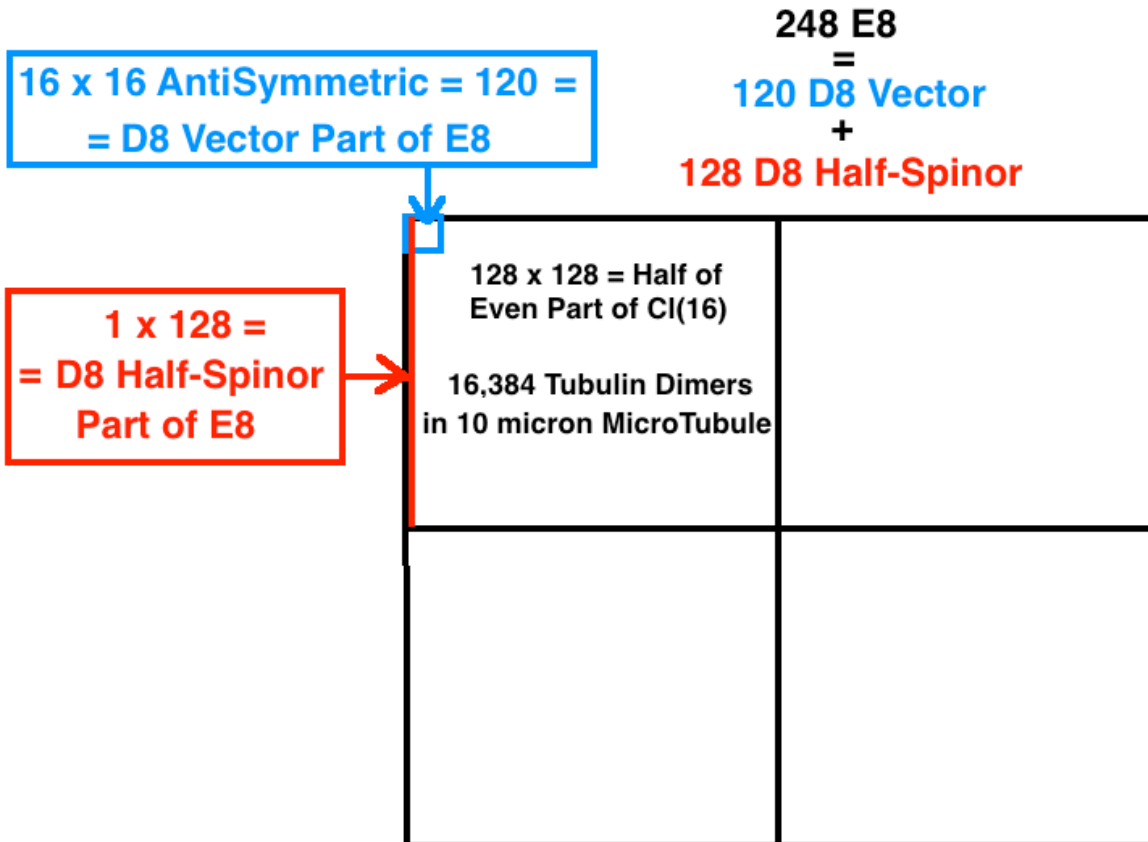

$E_8$  lives in only half of the block diagonal Even Part half of  $Cl(16)$  so that  $E_8$  of  $E_8$  Physics can be represented by the 16,384 Dimers of a 10 micron Microtubule.

According to 12biophys.blogspot.com Lecture 11 Microtubule structure is dynamic:  
 "... One end of the microtubule is composed of stable (GTP) monomers while the rest of the tubule is made up of unstable (GDP) monomers. The GTP end comprises a cap of stable monomers. Random fluctuations either increase or decrease the size of the cap. This results in 2 different dynamic states for the microtubule. Growing: cap is present Shrinking: cap is gone ...

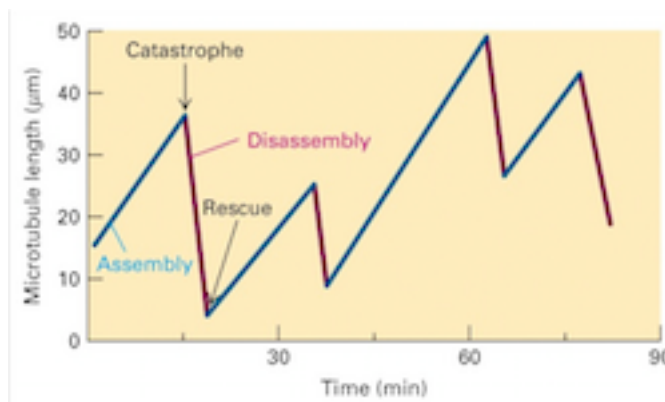

Microtubules spend most of their lives between 10 microns and 40 microns, sizes that can represent E8 as half of the Even Part (half) of Cl(16) ( 10 microns )

$$248 \text{ E8} = 120 \text{ D8 Vector } \square + 128 \text{ D8 Half-Spinor } \text{---}$$

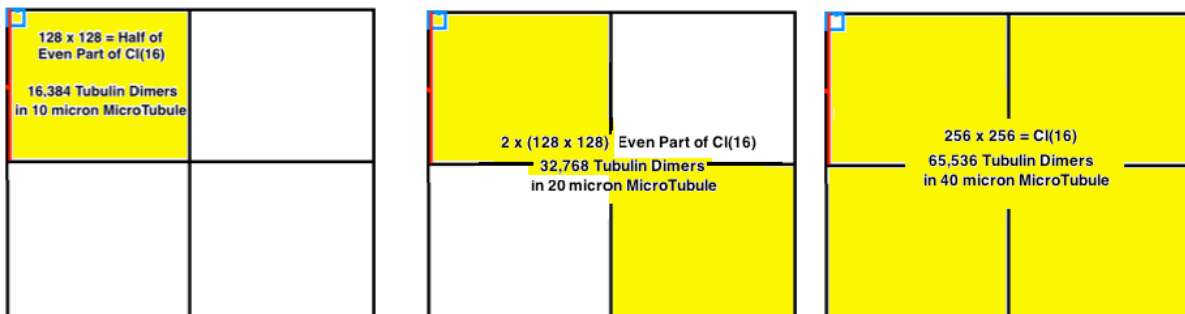

or as the Even Part (half) of Cl(16) ( 20 microns ) or as full Cl(16) ( 40 microns ).

In a given Microtubule  
the 128 D8 Half-Spinor part  is represented by a line of 128 Dimers in its stable GTP region and

the 120 D8 Vector part  by a 12 x 10 block of Dimers in its stable GTP region  
( image adapted from 12biophys.blogspot.com Lecture 11 )

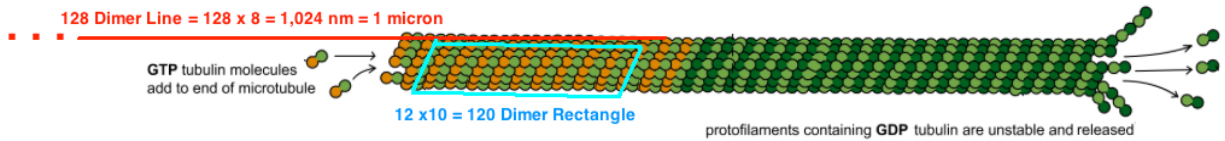

The image immediately above does not show how thin is the Microtubule.  
The following image ( from micro.magnet.fsu.edu ) shows overall Microtubule shape

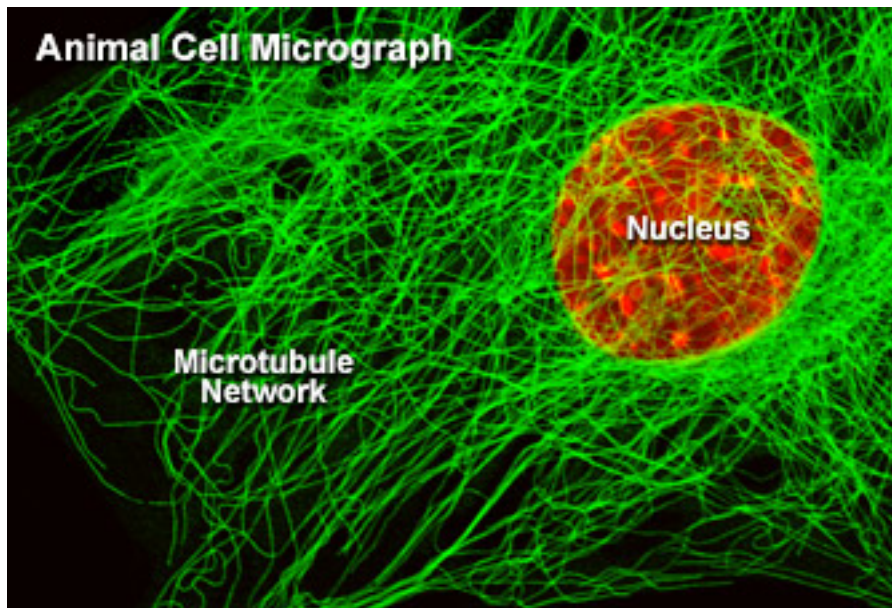

**How do the Microtubules communicate with each other ?**

Consider the Superposition of States State 0 and State 1 involving one Tubulin Dimer with Conformation Electron mass  $m$  and State1 / State 0 position separation  $a$  .

**The Superposition Separation Energy Difference is the internal energy**

$$E_{ssediff} = G m^2 / a$$

that can be seen as either the **energy of 26D String Theory spin two gravitons** or the **Bohm Quantum Potential internal energy**, equivalently.

Communication between two Microtubules is by the Bohm Quantum Potential between their respective corresponding Dimers ( purple arrow ) with the correspondence being based on connection between respective E8 subsets, the 128 D8 Half-Spinors ( red arrow ) and the 120 D8 BiVectors ( cyan arrow )

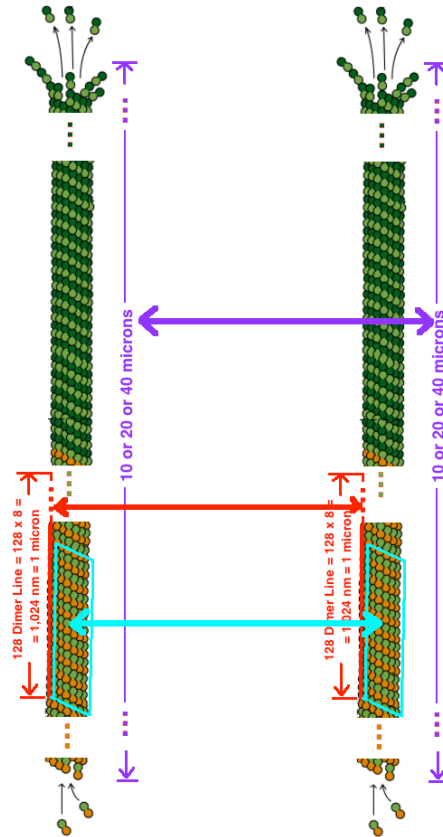

### How is information encoded in the Microtubules ?

Each Microtubule contains E8, allowing Microtubules to be correlated with each other. The parts of the Microtubule beyond E8 are in Cl(16) for 40 micron Microtubules, or the Even Subalgebra of Cl(16) for 20 micron Microtubules, or half of the Even Subalgebra of Cl(16) for 10 micron Microtubules so since by 8-Periodicity of Real Clifford Algebras  $Cl(16) = Cl(8) \times Cl(8)$  and since Cl(8) information is described by the Quantum Reed-Muller code  $[[ 256, 0, 24 ]]$  **the information content of Cl(16) and its Subalgebras is described by the Tensor Product Quantum Reed-Muller code  $[[ 256, 0, 24 ]]$  x  $[[ 256, 0, 24 ]]$**

For a 40-micron Microtubule there are, outside the 248-E8 part, about 65,000 TD Qubits available to describe one Quantum Thought State among about  $2^{65,000}$  possibilities, analogous to the Book of Genesis of  $(22+5)^{78,064}$  Hebrew Letter/Final possibilities.

**65,536-dimensional CI(16)** not only contains the E8 of E8 Physics and the information content of Microtubules but also contains **the information content of DNA chromosome condensation and the information content of mRNA triple - amino acid transformations.**

In “Living Matter: Algebra of Molecules” (CRC Press 2016) Valery V. Stcherbic and Leonid P. Buchatsky say: “... DNA structure contains four nucleotides: adenine A, guanine G, cytosine C and thymine T. ...”

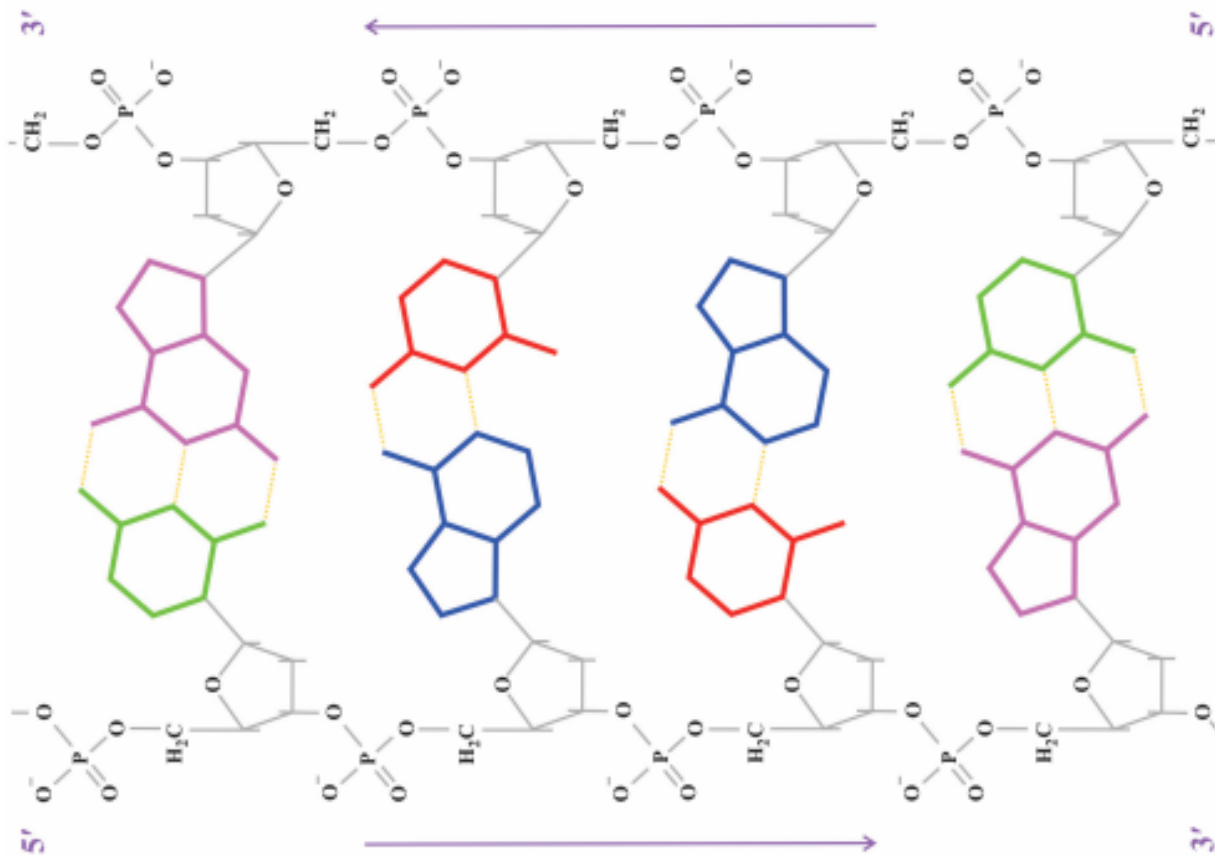

... The Sugar-phosphate group consists of 2-deoxyribose and phosphoric acid residues. DNA chain orientation is identified by carbon atoms of 2-deoxyribose: (5')CH<sub>2</sub> and (3')COH. The biological function of DNA and storage and transfer of genetic information to daughter cells is based on specific, complimentary pairing of nucleotides:

A is paired with T, and G with C.

...

... The Sugar-phosphate group consists of 2-deoxyribose and phosphoric acid residues. DNA chain orientation is identified by carbon atoms of 2-deoxyribose: (5')CH<sub>2</sub> and (3')COH. The biological function of DNA and storage and transfer of genetic information to daughter cells is based on specific, complimentary pairing of nucleotides:

A is paired with T, and G with C.



...

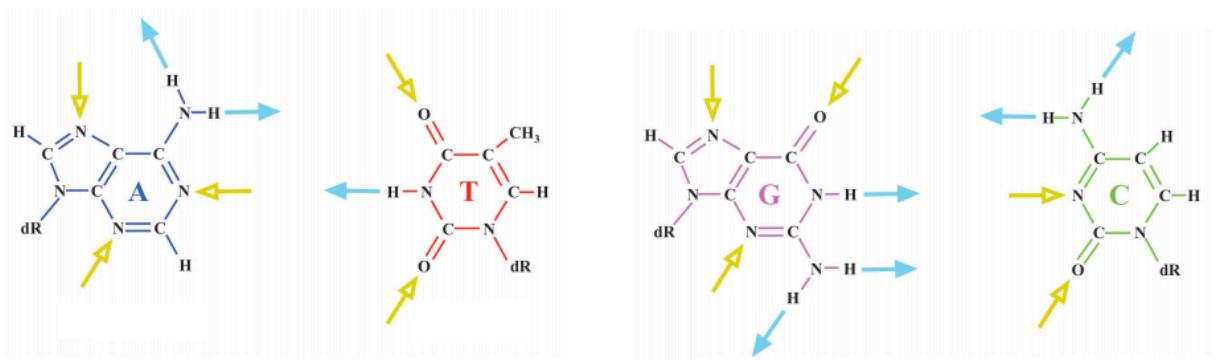

Figure 1.4 Potential vectors of hydrogen bond of DNA nucleotides.  
Yellow arrows—acceptors, blue arrows—donors of hydrogen.

The space of DNA nucleotide states contains  $2^3 \otimes 2^4 \otimes 2^5 \otimes 2^6 = 2^{18}$  elements of Clifford algebras. This space reduction to four nucleotides means compression of DNA information by a factor of  $2^{18} / 4 = 65536$ . Reduction of the nucleotide state space leads to DNA compactization and chromosome condensation. ...”.

In “Chromosome Condensation and Cohesion” (eLS December 2010) Laura Angelica Diaz-Martinez and Hongtau Yu say: “... The diploid human genome consists of 46 chromosomes, which collectively contain about 2 m of deoxyribonucleic acid (DNA). During mitosis, the genome is packaged into 46 pairs of sister chromatids, each less than 10  $\mu$ m long. ...”.

**The DNA information condensation factor of 65,536 is the dimension of Cl(16)  
which is  
the Real Clifford Algebra containing 248-dim E8 of E8 Physics  
as 120-dim bivector D8 plus 128-dim D8 half-spinor  
and is also  
the Clifford Algebra of Microtubule information in Quantum Consciousness.**

**Microtubule information = 65,536 = CI(16) = DNA condensation information**

Wikipedia describes interaction of Microtubules with DNA in mitosis condensation: “...

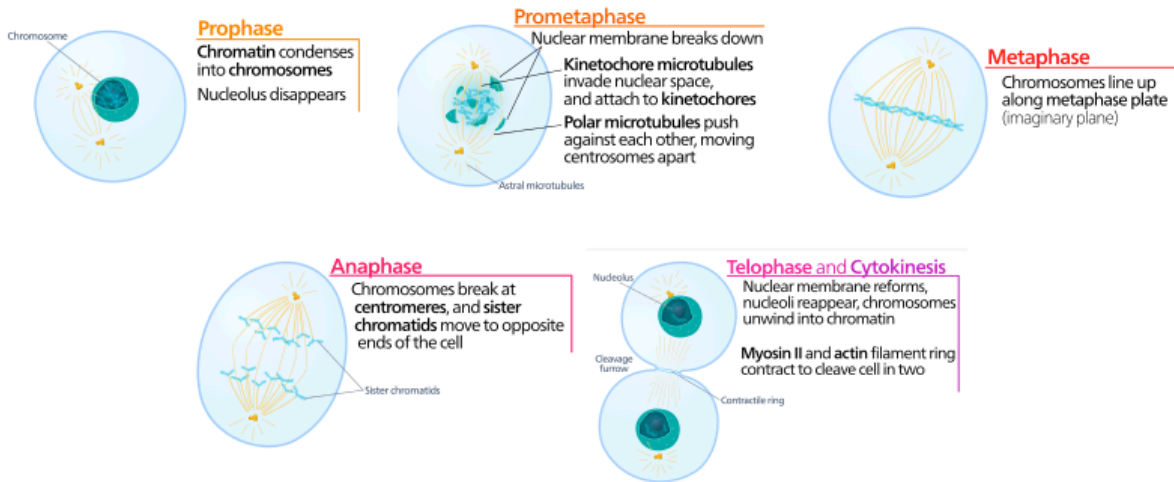

... Micrograph showing condensed chromosomes in blue, kinetochores in pink, and microtubules in green during metaphase of mitosis ...

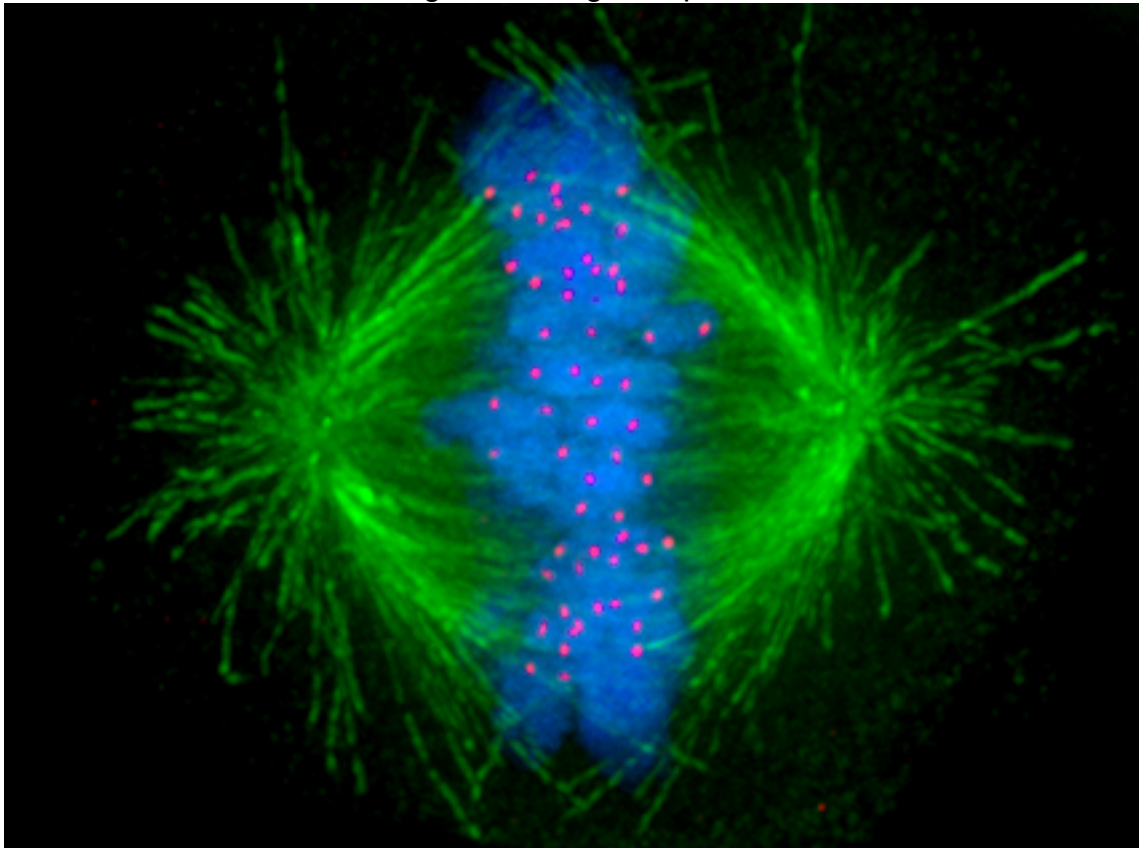

...”. Information lost by condensing DNA is stored in Microtubules through Anaphase after which it has been restored to the new Duplicated DNA.

Stcherbic and Buchatsky also say: "... Ribonucleic acid (RNA) can also store genetic information. A single RNA helix is seldom used as a carrier of genetic information (only in some viruses); its main role is storing DNA sites as copies of individual proteincoding genes (mRNA) or in formation of large structural complexes, e.g., ribosomes and spliceosomes. At self-splicing, RNA may perform the function of an enzyme. RNA also performs an important role during DNA replication. So called RNA-primers are necessary to synthesize DNA complementary chains, although this fact is not obvious. RNA contains sugar, ribose, which hydroxyl groups make more reactive than DNA. Besides, RNA contains uracil U, which is somewhat lighter than thymine.

...

At translation of mRNA triplets into genetic code amino acids, the dynamics of triplets to amino acids transformation should be taken into account.

...

At transition ... functional volume is equal to  $3^5 = 243$ .

To this volume there should be added the volume of auxiliary spaces, equal to  $13 = 5 + 4 + 3 + 1$ .

Accordingly, we get

256 functions of mRNA triplet transformation into amino acids of the genetic code.

Reverse transition ... from amino acids ... to triplet ... needs  $5^3 + 3^1 = 128$  functions.

In addition, 128 triplets of mRNA-tRNA pairing should be added to this number. ...".

**The 256 of mRNA triplet to amino acids is represented by  $Cl(8)$  Clifford algebra  
and  
the  $128+128 = 256$  of amino acids to mRNA triplets is represented by another  $Cl(8)$   
so  
that the mRNA triple - amino acid connection is represented by the tensor  
product  $Cl(8) \times Cl(8)$  which by 8-Periodicity of Real Clifford Algebras is the  
Real Clifford Algebra  $Cl(16)$   
which also contains 248-dim  $E_8$  of viXra 1508.0157  $E_8$  Physics  
and is also the Clifford Algebra  
of Microtubule information in viXra 1512.0300 Quantum Consciousness.**

## What about information in the Many Microtubules of Human Consciousness ?

The information in one Microtubule is based on CI(16)  
 which is contained in the CI(1,25) of 26D String Theory E8 Physics  
 (see Chapter on E8 Quantum Theory)

### How does this give rise to Penrose-Hameroff Quantum Consciousness ?

Consider the Superposition of States State 0 and State 1 involving one Tubulin Dimer with Conformation Electron mass  $m$  and State1 / State 0 position separation  $a$ .

**The Superposition Separation Energy Difference is the internal energy**

$$E_{\text{ssdiff}} = G m^2 / a$$

that can be seen as the **energy of 26D String Theory spin two gravitons** which physically represent the **Bohm Quantum Potential internal energy**.

(see Appendix - Details of World-Line String Bohm Quantum Theory)

For a given Tubulin Dimer  $a = 1$  nanometer =  $10^{-7}$  cm so that

$$T = h / E_{\text{electron}} = ( \text{Compton} / \text{Schwarzschild} ) ( a / c ) = 10^{26} \text{ sec} = 10^{19} \text{ years}$$

Now consider the case of  $N$  Tubulin Dimers in Coherent Superposition connected by the Bohm Quantum Potential Force that does not fall off with distance.

Jack Sarfatti defines coherence length  $L$  by  $L^3 = N a^3$  so that

the Superposition Energy  $E_N$  of  $N$  superposed Conformation Electrons is

$$E_N = G M^2 / L = N^{5/3} E_{\text{ssdiff}}$$

**The decoherence time for the system of  $N$  Tubulin Electrons is**

$$T_N = h / E_N = h / N^{5/3} E_{\text{ssdiff}} = N^{-5/3} 10^{26} \text{ sec}$$

so we have the following rough approximate Decoherence Times  $T_N$

Number of Involved Tubulin Dimers	Time $T_N$	
$10^{(11+9)} = 10^{20}$	$10^{(-33 + 26)} = 10^{(-7)} \text{ sec}$	$10^{11}$ neurons x $10^9$ TD / neuron $10^{20}$ Tubulin Dimers in Human Brain
$10^{16}$	$10^{(-27 + 26)} = 10^{(-1)} \text{ sec} - 10 \text{ Hz}$	Human Alpha EEG is 8 to 13 Hz Fundamental Schumann Resonance is 7.8 Hz
		Time of Traverse by a String World-Line Quantum Bohmion of a Quantum Consciousness Hamiltonian Circuit of $10^{16}$ TD separated from nearest neighbors by 10 nm is $10^{16} \times 10 \text{ nm} / c = (10^{16} \times 10^{(-6)}) \text{ cm} / c = 10^{10} \text{ cm} / c = 0.3 \text{ sec}$

Each cell of E8 Classical Lagrangian Spacetime corresponds to 65,536-dim Cl(16) which contains 248-dim E8 = 120-dim D8 bivectors +128-dim D8 half-spinors

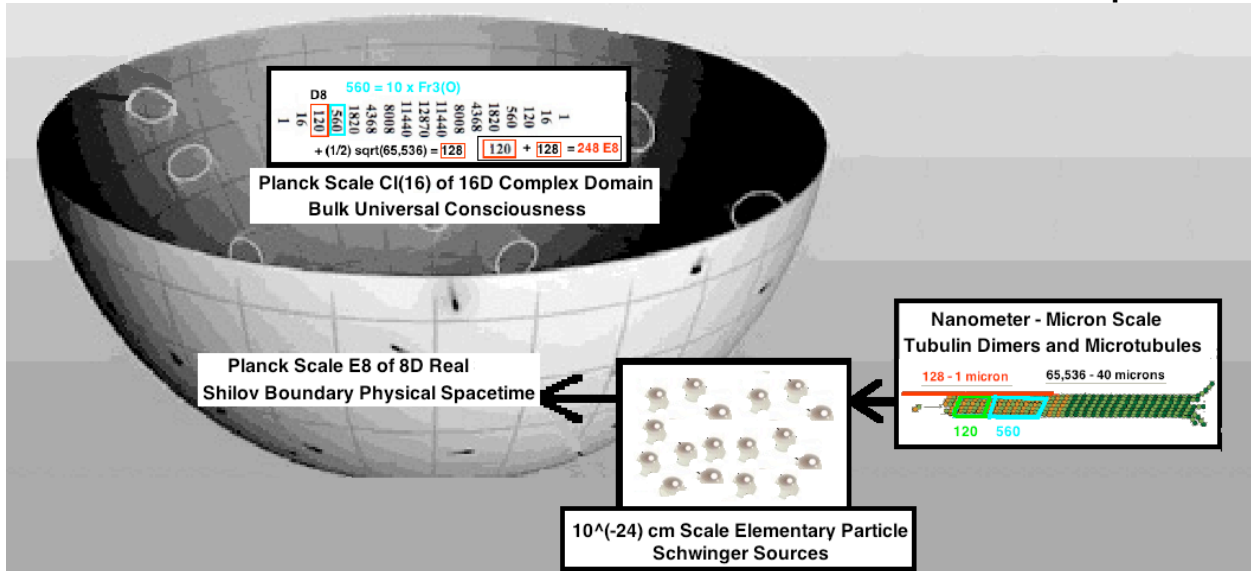

In E8 Physics ( viXra 1602.0319 )

**Spacetime is the 8-dimensional Shilov Boundary RP1 x S7**

**of the Type IV8 Bounded Complex Domain Bulk Space**

of the Symmetric Space Spin(10) / Spin(8)xU(1)

which **Bulk Space** has 16 Real dimensions

and is the Vector Space of the Real Clifford Algebra Cl(16).

By 8-Periodicity,

Cl(16) = tensor product Cl(8) x Cl(8) = Real 256x256 Matrix Algebra M(R,256)

and so has 256x256 = 65,536 elements.

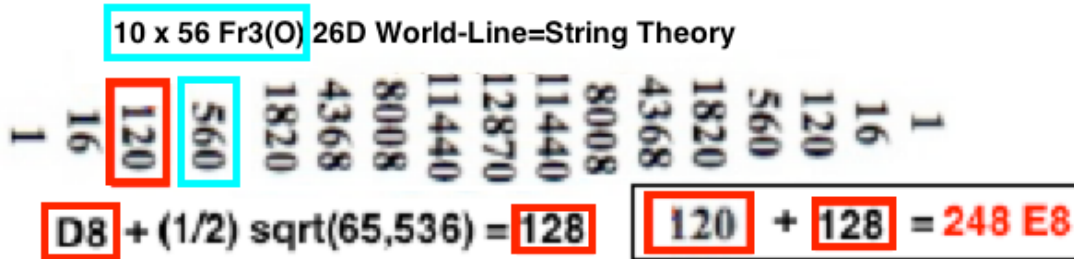

Cl(8) has 8 Vectors, 28 BiVectors, and 16 Spinors with 8+28+16 = 52 = F4 Lie Algebra.

Cl(16) has 120 BiVectors and 128 Half-Spinors for 120+128 = 248 = E8 Lie Algebra giving a Lagrangian for the Standard Model and for Gravity - Dark Energy.

Cl(16) has 560 TriVectors for 10 copies of Fr3(O) and Cl(1,25) AQFT

so 65,536 - 248 - 560 = 64,728 elements of Cl(16) are for Consciousness Information.

The Complex Bulk Space Cl(16)

contains the Maximal Contraction of E8 which is H92 + A7

a generalized Heisenberg Algebra of Quantum Creation-Annihilation Operators with graded structure

$$28 + 64 + ((SL(8,R)+1) + 64 + 28$$

We live in the Physical Minkowski M4 part  
of Kaluza-Klein M4 x CP2 structure of RP1 x S7 **Boundary**.  
(where CP2 = SU(3) / SU(2)xU(1) is Internal Symmetry Space  
of Standard Model gauge groups)

Our Consciousness is based on Binary States of Tubulin Dimers (each 4x4x8 nm size)  
in Microtubules.



Microtubules are cylinders of sets of 13 Dimers with maximal length about 40,000 nm  
so that  
each Microtubule can contain about  $13 \times 40,000 / 8 = 65,000$  Bits of Information.

The Physical Boundary in which we live  
is a Real Shilov Boundary in which E8 is manifested  
as Lagrangian Structure of Real Forms of E8  
with Lagrangian Symmetric Space structure:

- E8 / D8 = (OxO)P2 for 8 componets of 8+8 First-Generation Fermions
- D8 / D4 x D4 for 8-dim spacetime position x 8-dim spacetime momentum
- D4 for Standard Model Gauge Bosons and Gravity - Dark Energy Ghosts
- D4 for Gravity - Dark Energy Gauge Bosons and Standard Model Ghosts

Microtubule Information in the Boundary  
has Resonant Connection to Cl(16) Information in Bulk Space  
by the spin-2 Bohm Quantum Potential with Sarfatti Back-Reaction  
of 26D String Theory of World-Lines  
consistent with Poisson Kernel as derivative of Green's function.

The Bulk Space Domain Type IV8  
corresponds to the Symmetric Space Spin(10) / Spin(8)xU(1)  
and is a Lie Ball whose Shilov Boundary RP1 x S7 is a Lie Sphere 8-dim Spacetime.

It is related to  
the Stiefel Manifold  $V(10,2) = \text{Spin}(10) / \text{Spin}(8)$  of dimension  $20-3 = 17$  by the fibration  
 $\text{Spin}(10) / \text{Spin}(8)xU(1) \rightarrow V(10,2) \rightarrow U(1)$

It can also be seen as a tube  $z = x + iy$   
whose imaginary part is physically inverse momentum  
so that its points give both position and momentum

(R. **Coquereaux** Nuc. Phys. B. 18B (1990) 48-52) "Lie Balls and Relativistic Quantum Fields".

Human Brain Microtubules 40 microns long have 65,536 Tubulin Dimers

128 - 1 micron

65,536 - 40 microns



( image adapted from 12biophys.blogspot.com Lecture 11 )

and so

can have Bohm Quantum Resonance with CI(16) Spacetime cells

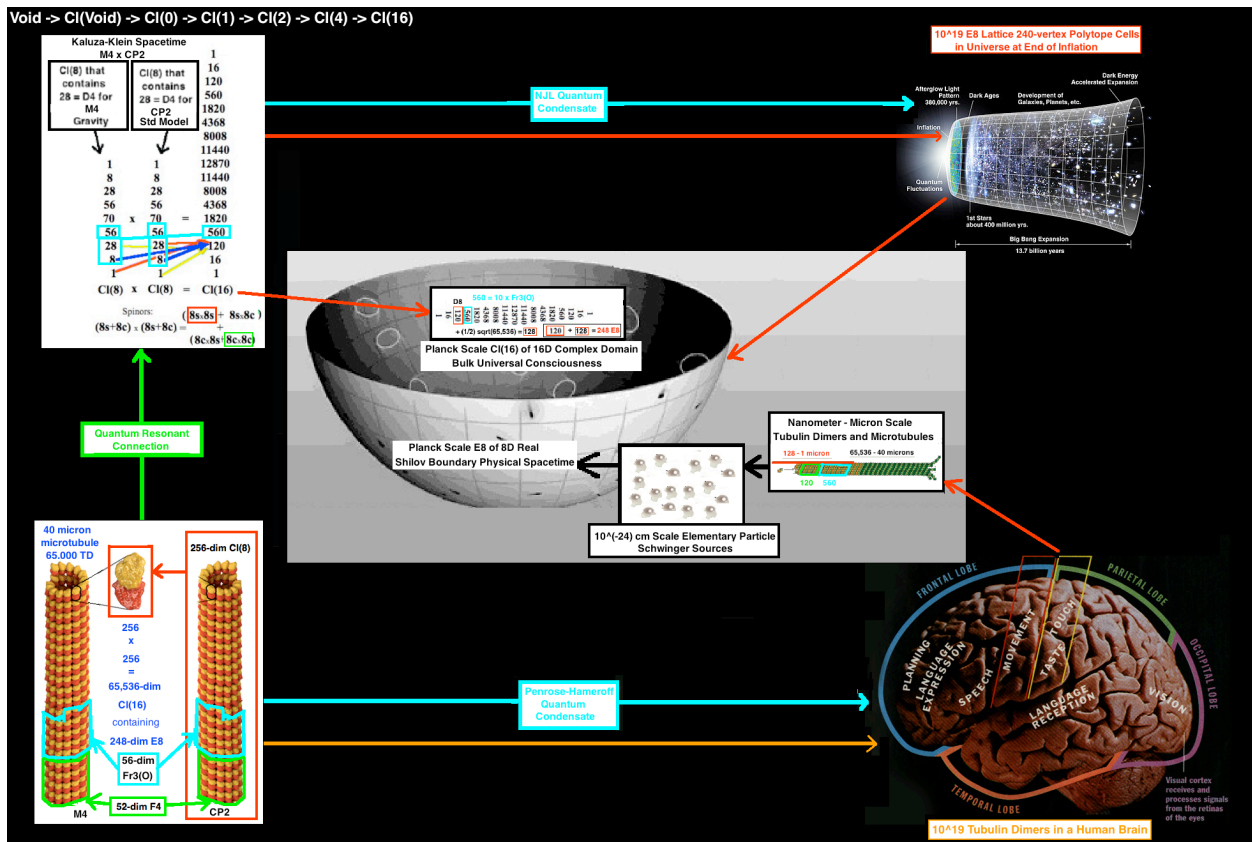

so that at any and all Times  
**the State of Consciousness of a Human**  
**is in exact resonant correspondence with**  
**a subset of the cells of E8 Classical Lagrangian Spacetime**

Therefore

**E8 Classical Lagrangian Spacetime N-JL Condensate is effectively the Spirit World**  
**in which the Human States of Consciousness = Souls exist.**

After the death of the Human Physical Body the Spirit World interactions with its Soul

are no longer constrained by Physical World interactions with its Body so that the Spirit World can harmonize the individual Soul with the collective Universal Soul.

**William Kingdon Clifford (1845 - 1879) who invented Real Clifford Algebras called them “mind-stuff”, saying:**

**“... When matter takes the complex form of a living human brain, the corresponding mind-stuff takes the form of a human consciousness ...”.**

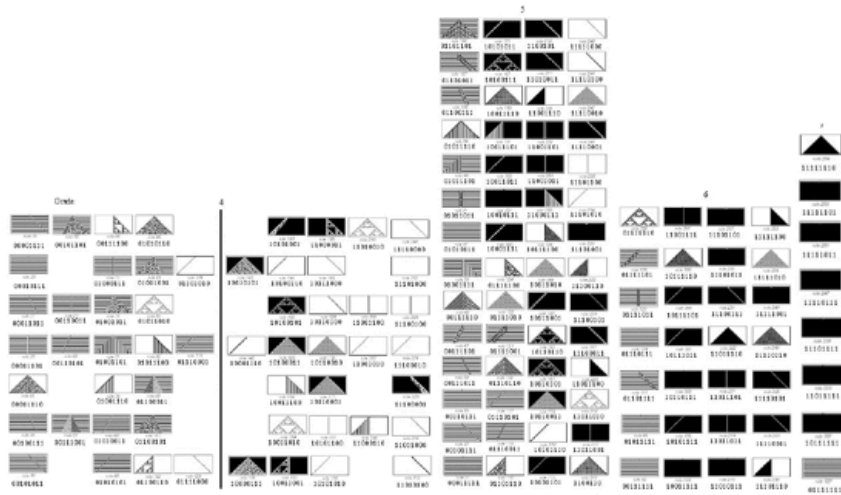

The 52 F4 and 56 Fr3(O) elements of Cl(8) describe the Natural Laws of Physics and the other 256 - 108 = 148 elements of Cl(8) can carry Consciousness Information.

At the level of Cl(16) = Cl(8) x Cl(8) the 248 of E8 and 560 of 10 copies of Fr3(O) describe the Natural Laws of Physics and the other 65,536 - 248 - 560 = 64,728 can carry Consciousness Information.

Terence McKenna said May 1993 OMNI magazine: “... From 75,000 to about 15,000 years ago, there was a ... human paradise on Earth ...

Entities there are ... teaching something.

Theirs is a higher dimensional language that condenses as a visible syntax ...

they ... offer you an object so beautiful, so intricately wrought, so something else that cannot be said in English ...

The object generates other objects ...

There are actual attractors ahead of us in time ...”.

**McKenna’s Higher Dimensional Language =  
= Mind-Stuff of Real Clifford Algebras.**



# Schwinger Sources

## Visualization of Schwinger Sources How to Visualize a Schwinger Source in 7 Steps:

First, look at the 240-vertex E8 Root Vector representation of the Valence Fermion of the Schwinger Source Cloud. It is two 600-cells, each with 120 vertices:

H4 M4 representing Conformal Gravity and the M4 part of M4 x CP2 Kaluza-Klein where M4 = 4D Minkowski Physical Spacetime and  
H4 CP2 representing the Standard Model and the CP2 part of M4 x CP2 where CP2 = SU(3) / SU(2) x U(1) Internal Symmetry Space

The H4 M4 600-cell is larger than the H4 CP2 600-cell by the Golden Ratio

**E8 240 Root Vectors =**

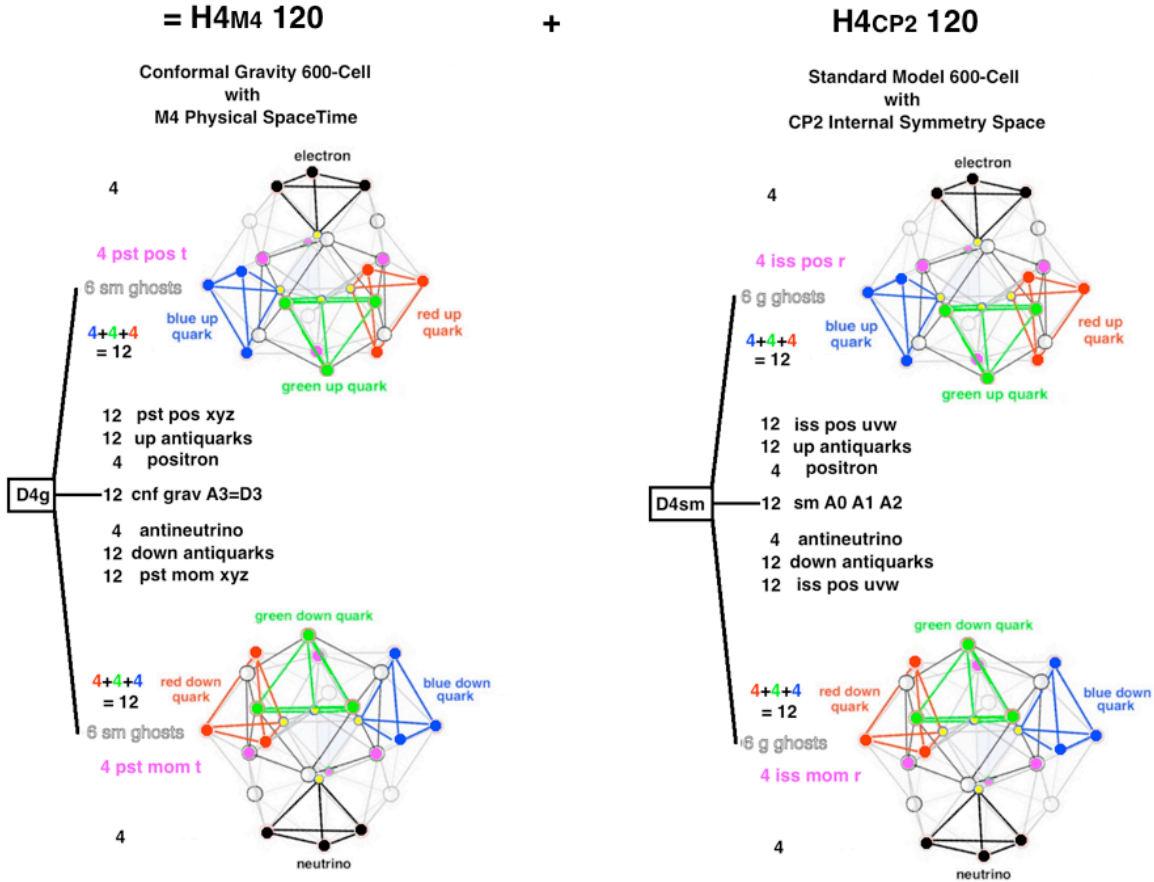

Each First-Generation Fermion is represented by a 4-vertex Tetrahedron in the H4 M4 600-cell and in the H4 CP2 600-cell.

**The Valence Fermion is represented as the corresponding two Tetrahedra being activated.**

Second, look only at the H4 M4 600-cell to see how the Valence Fermion looks in M4 Minkowski Physical Spacetime:

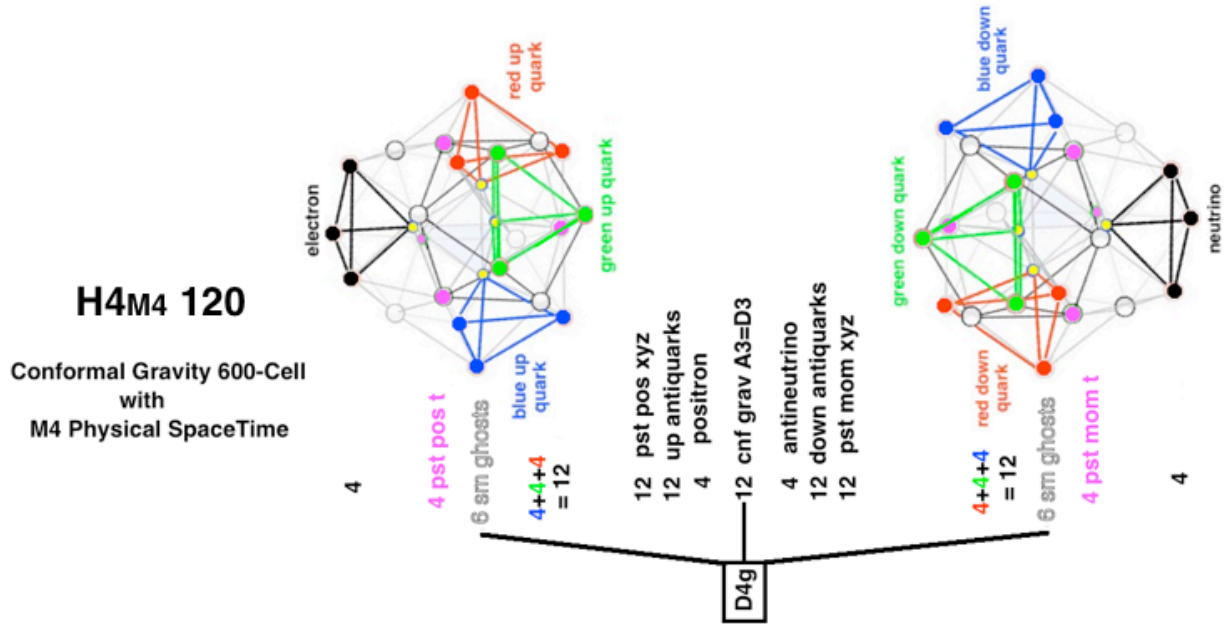

Third, look at the Fibonacci Shell Structure of the M4 part of the Schwinger Source Cloud

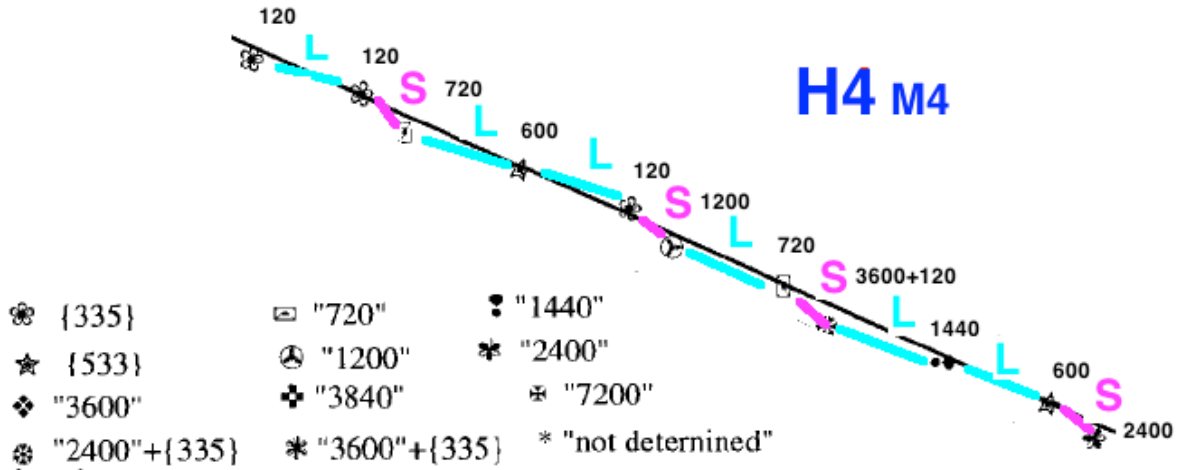

Fourth, look only at the H4 CP2 600-cell to see how the Valence Fermion looks in CP2 Internal Symmetry Space:

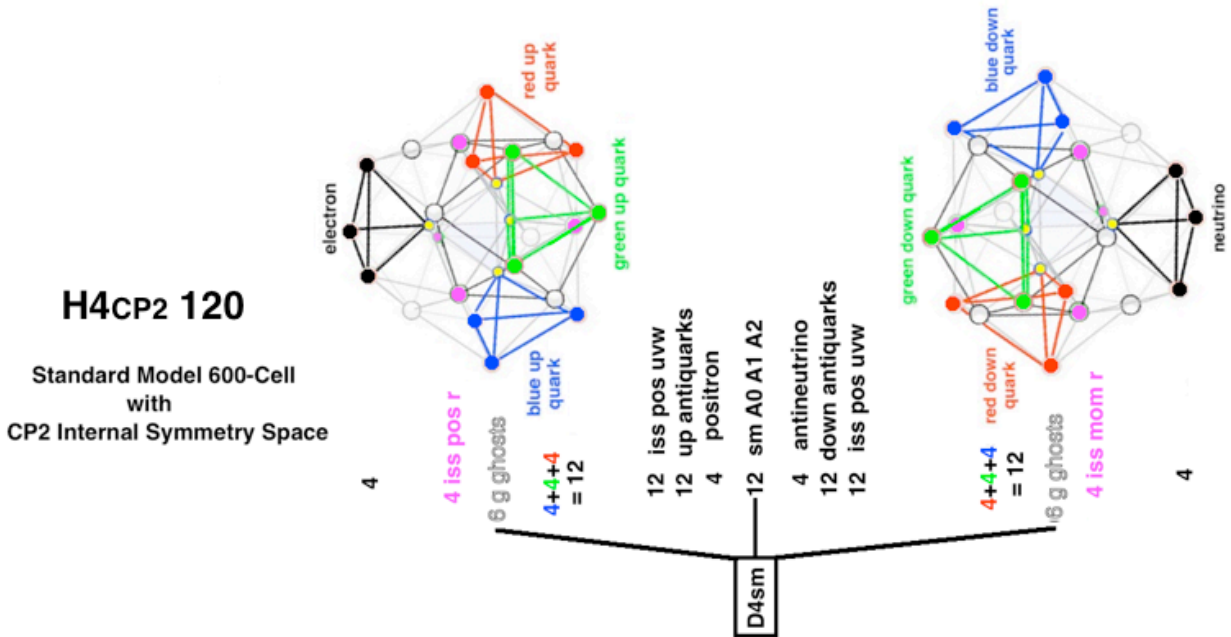

Fifth, look at the Fibonacci Shell Structure of the CP2 part of the Schwinger Source Cloud

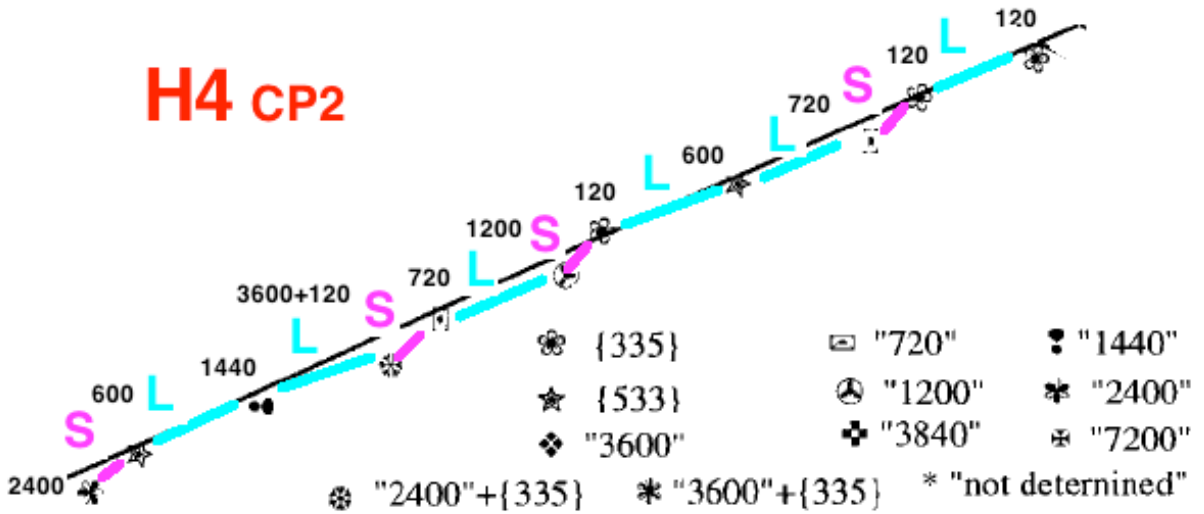

Sixth,  
look at the combined Shell Structures of H4 M4 and H4 CP2:

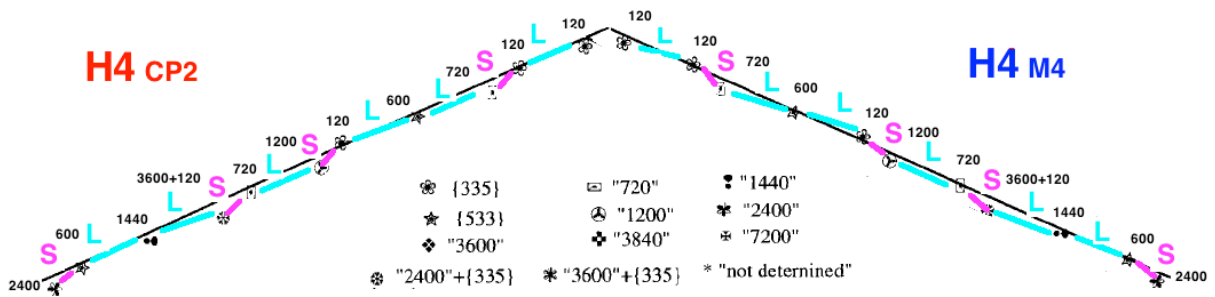

At this stage, you see the M4 and CP2 parts of the Schwinger Source Cloud  
but  
you have not yet seen the full E8 Schwinger Source Cloud.  
For that, you need to go to the 7th Step:

Seventh,  
combine the H4 M4 and H4 CP2 parts to form the full E8 Schwinger Source:

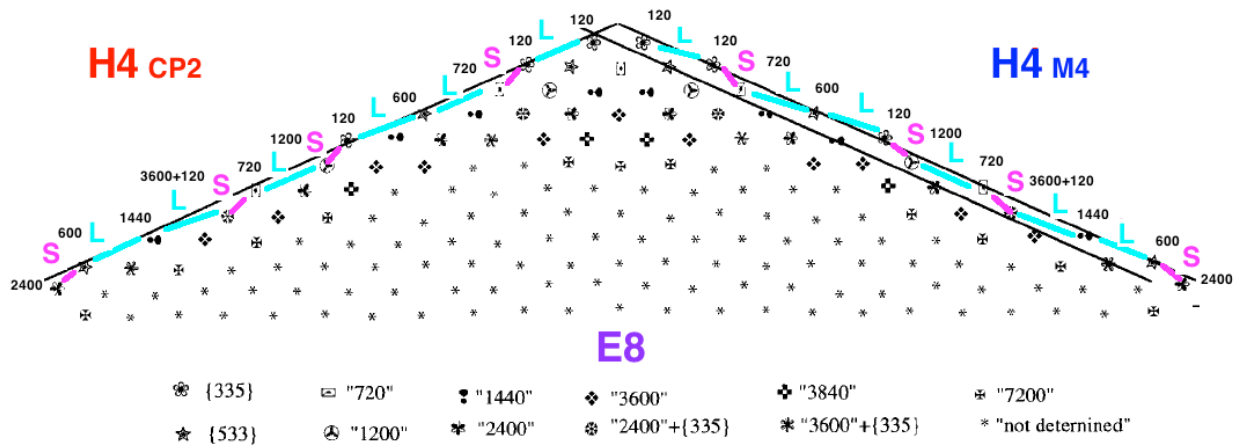

## How does the Schwinger Source look on larger scales ?

In the 4D M4 Minkowski Physical Spacetime part of M4 x CP2 Kaluza-Klein it looks like a Gravitational Black Hole.

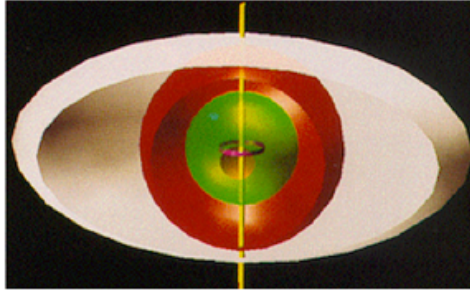

Ergosphere (white), Outer Event Horizon (red), Inner Event Horizon (green), and Ring Singularity (purple)  
from Black Holes - A Traveller's Guide, by Clifford Pickover (Wiley 1996).

**David Finkelstein invented the one-way membrane of the Black Hole.  
David's Black Hole can be generalized to deal with Spin  
and the. ( -1 +1 ) Charge of the U(2) ElectroWeak Force**

The generalization is called a Kerr-Newman Black Hole,

The Zeldovich-Hawking Process,  
in which a Virtual Particle-AntiParticle Pair near the Event Horizon can be separated  
with one of the Virtual Pair going into the Black Hole  
and  
the other going into External Spacetime,

can be applied to Quark-AntiQuark Virtual Pairs showing that

**a Black Hole can carry Color Charge of the SU(3) Color Force.**

## What is the Geometrical Symmetry Structure of each type of Schwinger Source?

### Neutrino:

Volume in 4D Minkowski M4 is Complex Bounded Domain type IV4  
with Symmetric Space Spin(6) / Spin(4)xU(1) Lie Ball  
and Shilov Boundary RP1 x S3 Lie Sphere

Volume in 8D is Complex Bounded Domain type IV8  
with Symmetric Space Spin(10) / Spin(8)xU(1) Lie Ball  
and Shilov Boundary RP1 x S7 Lie Sphere

By Triality the 8D M4 Spacetime Shilov Boundary Lie Sphere  
is isomorphic to the 8D CP2 Fermion Particle Symmetry Space  
Lie Sphere RP1 x S7 Shilov Boundary  
with basis  $\{1, i, j, k, E, I, J, K\} = \{Nu, rDQ, gDQ, bDq, E, rUQ, gUQ, bUQ\}$   
and  
to the corresponding  
8D CP2 Fermion AntiParticle Symmetry Space

Conformal Gravity has 15 generators.  
1 is the Dilaton corresponding to the Higgs  
4 are Special Conformal corresponding to Dark Energy  
10 are anti-deSitter for Einstein-Hilbert Gravity  
2 of the 10 are Cartan Subalgebra  
8 of the 10 can carry Charges  
6 of the 8 carry SU(3) Color Charge ( R G B )  
2 of the 8 can carry U(2) ElectroWeak Charge ( -1 +1 )  
1 of the 2 carries Charge 0 of the Neutrino  
which gives the Neutrino mass formula a Graviton factor of 0  
so that the tree-level Neutrino mass is Zero.

The Neutrino is only related to the RP1 of  $S^7 \times RP^1$   
because the Neutrino carries only no Charge  
so  
the Neutrino should have at tree level  
a spinor manifold volume factor  $V(Q_{\text{neutrino}})$  of unit volume of Zero.

## Electron:

Volume in 4D Minkowski M4 is Complex Bounded Domain type IV4  
with Symmetric Space Spin(6) / Spin(4)xU(1) Lie Ball  
and Shilov Boundary RP1 x S3 Lie Sphere

Volume in 8D is Complex Bounded Domain type IV8  
with Symmetric Space Spin(10) / Spin(8)xU(1) Lie Ball  
and Shilov Boundary RP1 x S7 Lie Sphere

By Triality the 8D M4 Spacetime Shilov Boundary Lie Sphere  
is isomorphic to the 8D CP2 Fermion Particle Symmetry Space  
Lie Sphere RP1 x S7 Shilov Boundary  
with basis  $\{1, i, j, k, E, I, J, K\} = \{N_u, rDQ, gDQ, bDq, E, rUQ, gUQ, bUQ\}$   
and  
to the corresponding  
8D CP2 Fermion AntiParticle Symmetry Space

Conformal Gravity has 15 generators.  
1 is the Dilaton corresponding to the Higgs  
4 are Special Conformal corresponding to Dark Energy  
10 are anti-deSitter for Einstein-Hilbert Gravity  
2 of the 10 are Cartan Subalgebra  
8 of the 10 can carry Charges  
6 of the 8 carry SU(3) Color Charge ( R G B )  
2 of the 8 can carry U(2) ElectroWeak Charge ( -1 +1 )  
1 of the 2 carries Charge +1 of the Electron  
which gives the Electron mass formula a Graviton factor of 1.

The Electron is only related to the equatorial S1 = U(1) of the S7 of S<sup>7</sup> x RP<sup>1</sup>  
because the Electron carries only U(1) ElectroWeak Charge  
so  
the Electron should have  
a spinor manifold volume factor V(Qelectron) of unit volume of S1 = U(1).

### **Down Quark (either Red, Green, or Blue):**

Volume in 4D Minkowski M4 is Complex Bounded Domain type IV4  
with Symmetric Space Spin(6) / Spin(4)xU(1) Lie Ball  
and Shilov Boundary RP1 x S3 Lie Sphere

Volume in 8D is Complex Bounded Domain type IV8  
with Symmetric Space Spin(10) / Spin(8)xU(1) Lie Ball  
and Shilov Boundary RP1 x S7 Lie Sphere

By Triality the 8D M4 Spacetime Shilov Boundary Lie Sphere  
is isomorphic to the 8D CP2 Fermion Particle Symmetry Space  
Lie Sphere RP1 x S7 Shilov Boundary  
with basis  $\{1, i, j, k, E, I, J, K\} = \{N_u, rDQ, gDQ, bDq, E, rUQ, gUQ, bUQ\}$   
and

to the corresponding  
8D CP2 Fermion AntiParticle Symmetry Space

Conformal Gravity has 15 generators.  
1 is the Dilaton corresponding to the Higgs  
4 are Special Conformal corresponding to Dark Energy  
10 are anti-deSitter for Einstein-Hilbert Gravity  
2 of the 10 are Cartan Subalgebra  
8 of the 10 can carry Charges  
6 of the 8 carry SU(3) Color Charge ( R G B )  
which gives the Down Quark mass formula a Graviton factor of 6.

The Down Quarks correspond to Octonions i, j, k  
which, by gluon interactions, can be taken into each other.

By also using weak boson interactions,  
they can also be taken into I, J, and K, the red, blue, and green Up Quarks.  
Given the Up and Down quarks, Pions can be formed from quark-antiquark pairs,  
and the Pions can decay to produce electrons and neutrinos.

Therefore the Down Quarks are related to all parts of  $S^7 \times RP^1$ ,  
the compact manifold corresponding to  $\{1, i, j, k, E, I, J, K\}$   
and therefore a Down Quark should have  
a spinor manifold volume factor  $V(Q_{\text{down quark}})$  of the volume of  $S^7 \times RP^1$ .

The ratio of the Down Quark spinor manifold volume factor  
to the Electron spinor manifold volume factor is  
 $V(Q_{\text{down quark}}) / V(Q_{\text{electron}}) = V(S^7 \times RP^1) / 1 = \pi^5 / 3$ .  
Since the first generation graviton factor is 6 for Down Quarks and 1 for Electron  
 $m_d / m_e = 6 V(S^7 \times RP^1) = 2 \pi^5 = 612.03937$



### Up Quark (either Red, Green, or Blue):

Volume in 4D Minkowski M4 is Complex Bounded Domain type IV4  
with Symmetric Space Spin(6) / Spin(4)xU(1) Lie Ball  
and Shilov Boundary RP1 x S3 Lie Sphere

Volume in 8D is Complex Bounded Domain type IV8  
with Symmetric Space Spin(10) / Spin(8)xU(1) Lie Ball  
and Shilov Boundary RP1 x S7 Lie Sphere

By Triality the 8D M4 Spacetime Shilov Boundary Lie Sphere  
is isomorphic to the 8D CP2 Fermion Particle Symmetry Space  
Lie Sphere RP1 x S7 Shilov Boundary  
with basis  $\{1, i, j, k, E, I, J, K\} = \{N_u, rDQ, gDQ, bDq, E, rUQ, gUQ, bUQ\}$   
and  
to the corresponding  
8D CP2 Fermion AntiParticle Symmetry Space

Conformal Gravity has 15 generators.  
1 is the Dilaton corresponding to the Higgs  
4 are Special Conformal corresponding to Dark Energy  
10 are anti-deSitter for Einstein-Hilbert Gravity  
2 of the 10 are Cartan Subalgebra  
8 of the 10 can carry Charges  
6 of the 8 carry SU(3) Color Charge ( R G B )  
which gives the Up Quark mass formula a Graviton factor of 6.

As the up quarks correspond to I, J, and K,  
which are the octonion transforms under E of i, j, and k of the down quarks,  
the up quarks and down quarks have the same constituent mass  
 $\mu = m_d$ .

Antiparticles have the same mass as the corresponding particles.

Since the model only gives ratios of masses,  
the mass scale is fixed so that the electron mass  $m_e = 0.5110$  MeV.  
Then, the constituent mass of the down quark is  $m_d = 312.75$  MeV,  
and the constituent mass for the up quark is  $\mu = 312.75$  MeV.  
These results when added up give a total mass of first generation fermion particles:  
 $\Sigma_{maf1} = 1.877$  GeV

The proton mass is taken to be  
the sum of the constituent masses of its constituent quarks  
so  
 $m_{proton} = \mu + \mu + m_d = 938.25$  MeV  
which is close to the experimental value of 938.27 MeV.

## Second and Third Generation Fermions:

First Generation Fermions are represented by Octonions with 8 basis elements { 1, i, j, k, E, I, J, K }

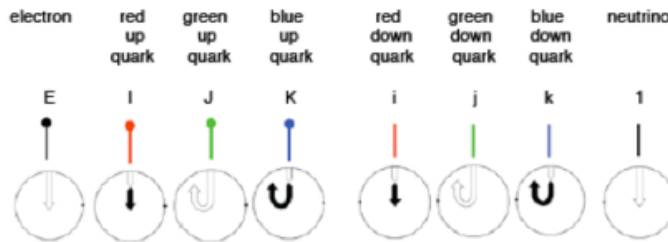

1 = 1 = Neutrino

1 = E = electron

3 = i, j, k = Down Quarks (r,g,b = 3)

3 = I, J, K = Up Quarks (r,g,b = 3)

**Second Generation Fermions** are represented by Pairs of Octonions with  $8 \times 8 = 64$  basis elements

1 = {11} = Mu Neutrino

3 = 2+1 = {1E,E1,EE} = Muon

9 = 3x3 = {1r,r1,rr or 1g,g1,gg or 1b,b1,bb} = Strange Quarks (r,g,b = 3)

51 = 17x3 = Charm Quarks (r,g,b = 3)

Example: Blue Charm Quark

Rules: a Pair belongs to the Blue Charm Quark if:

1 - There is at least one Blue element and the other element is Blue or Colorless (black) and at least one element is NonAssociative (that is, is either E or I or J or K)

2 - There is one Red element and one Green element (Red x Green = Blue).

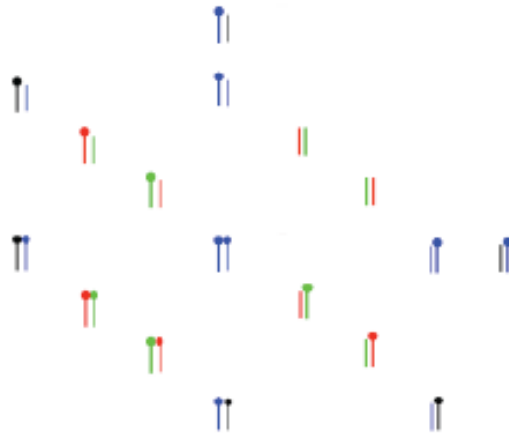

**Third Generation Fermions** are represented by Triples of Octonions  
with  $8 \times 8 \times 8 = 512$  basis elements

$$\begin{aligned}
 1 &= \{111\} = \text{Tau Neutrino} \\
 7 &= 3+3+1 = \{11E, 1E1, E11, EE1, E1E, 1EE, EEE\} = \text{Tauon} \\
 21 &= 7 \times 3 = \text{Beauty Quarks (r,g,b = 3)} \\
 483 &= 161 \times 3 = 23 \times 7 \times 3 = \text{Truth Quarks (r,g,b = 3)}
 \end{aligned}$$

Example: Blue Truth Quark

Rules: a Triple belongs to the Blue Truth Quark if:

- 1 - There is at least one Blue element and all other elements are Blue or Colorless (black) and at least one element is NonAssociative (that is, is either E or I or J or K)
- 2 - There is one Red element and one Green element and the other element is Colorless (Red x Green = Blue)
- 3 - The Triple has one element each that is Red, Green, or Blue, in which case the color of the Third element (for Third Generation) is determinative and must be Blue.

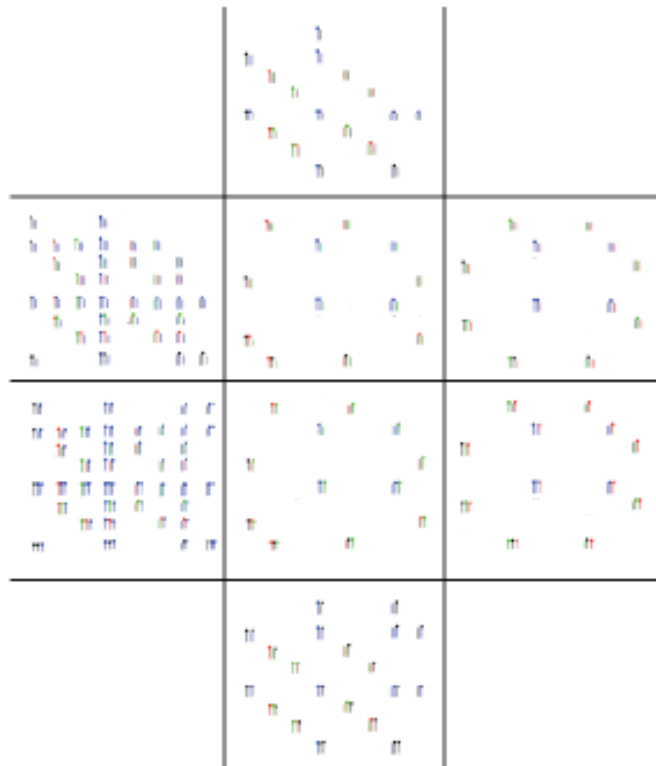

In the  $Cl(1,25)$  E8 model, the first generation spinor fermions are seen as +half-spinor and -half-spinor spaces of  $Cl(1,7) = Cl(8)$ .

Due to Triality,

$Spin(8)$  can act on those 8-dimensional half-spinor spaces similarly to the way it acts on 8-dimensional vector spacetime.

Take the the spinor fermion volume to be the Shilov boundary corresponding to the same symmetric space on which  $Spin(8)$  acts as a local gauge group that is used to construct 8-dimensional vector spacetime:

the symmetric space  $Spin(10) / Spin(8) \times U(1)$

corresponding to a bounded domain of type IV8

whose Shilov boundary is  $RP^1 \times S^7$

Since all first generation fermions see the spacetime over which the integral is taken in the same way ( unlike what happens for the force strength calculation ), the only geometric volume factor relevant for calculating first generation fermion mass ratios is in the spinor fermion volume term.

$Cl(1,25)$  E8 model fermions correspond to Schwinger Source Kerr-Newman Black Holes,

so the quark mass in the  $Cl(1,25)$  E8 model is a constituent mass.

Fermion masses are calculated as a product of four factors:

$$V(Qfermion) \times N(Graviton) \times N(octonion) \times Sym$$

$V(Qfermion)$  is the volume of the part of the half-spinor fermion particle manifold  $S^7 \times RP^1$  related to the fermion particle by photon, weak boson, or gluon interactions.

$N(Graviton)$  is the number of types of  $Spin(0,5)$  graviton related to the fermion.

The 10 gravitons correspond to the 10 infinitesimal generators of  $Spin(0,5) = Sp(2)$ . 2 of them are in the Cartan subalgebra.

6 of them carry color charge, and therefore correspond to quarks.

The remaining 2 carry no color charge, but may carry electric charge and so may be considered as corresponding to electrons.

One graviton takes the electron into itself, and the other can only take the first-generation electron into the massless electron neutrino. Therefore only one graviton should correspond to the mass of the first-generation electron. The graviton number ratio of the down quark to the first-generation electron is therefore  $6/1 = 6$ .

$N(octonion)$  is an octonion number factor relating up-type quark masses to down-type quark masses in each generation.

$Sym$  is an internal symmetry factor, relating 2nd and 3rd generation massive leptons to first generation fermions. It is not used in first-generation calculations.

### 3 Generation Fermion Combinatorics

#### First Generation (8)

(geometric representation of Octonions is from arXiv 1010.2979 )

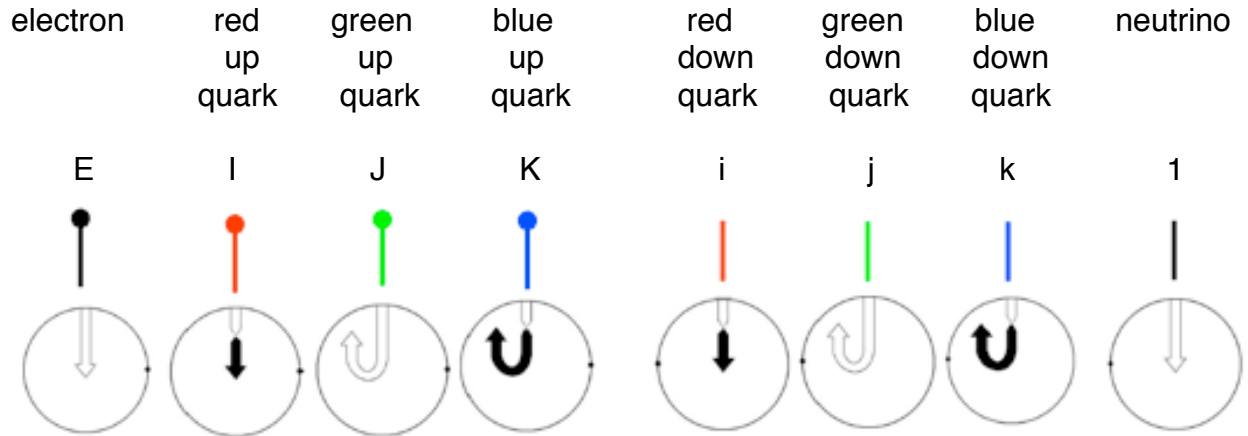

#### Second Generation (64)

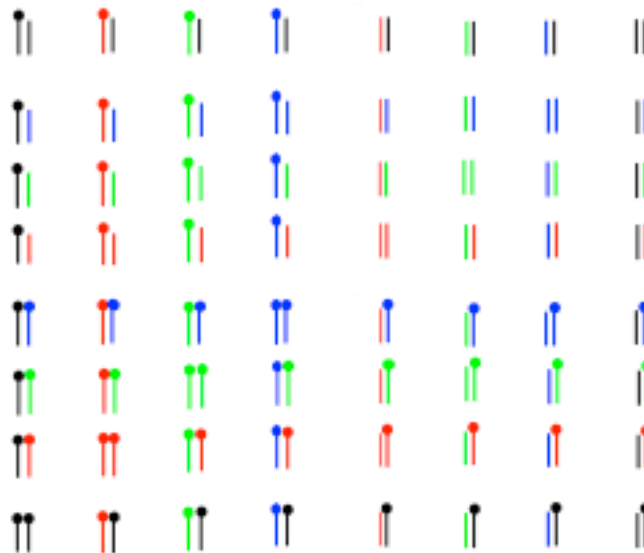

Mu Neutrino (1)

Rule: a Pair belongs to the Mu Neutrino if:  
 All elements are Colorless (black)  
 and all elements are Associative

(that is, is 1 which is the only Colorless Associative element) .

### Muon (3)

Rule: a Pair belongs to the Muon if:  
All elements are Colorless (black)  
and at least one element is NonAssociative  
(that is, is E which is the only Colorless NonAssociative element).

### Blue Strange Quark (3)

Rule: a Pair belongs to the Blue Strange Quark if:  
There is at least one Blue element and the other element is Blue or Colorless (black)  
and all elements are Associative (that is, is either 1 or i or j or k).

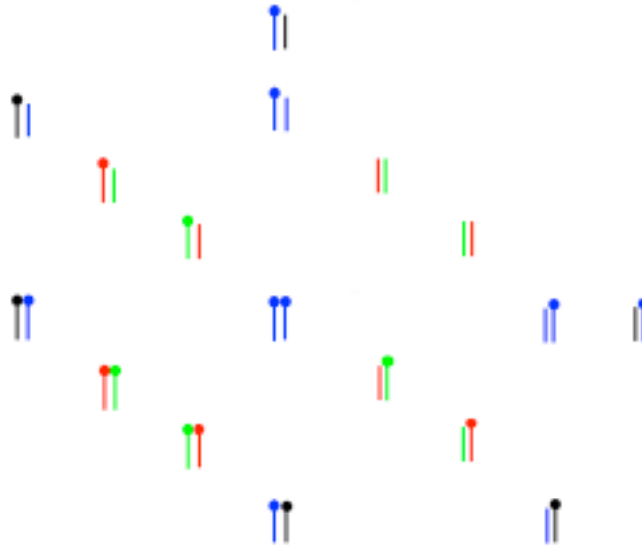

### Blue Charm Quark (17)

Rules: a Pair belongs to the Blue Charm Quark if:  
1 - There is at least one Blue element and the other element is Blue or Colorless (black)  
and at least one element is NonAssociative (that is, is either E or I or J or K)  
2 - There is one Red element and one Green element (Red x Green = Blue).

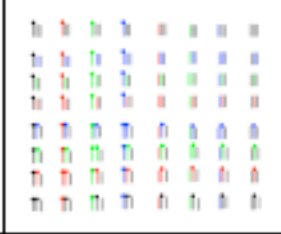
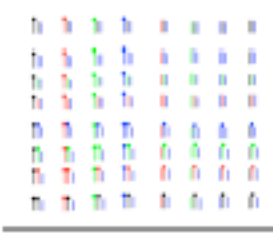

( Red and Green Strange and Charm Quarks follow similar rules )

### Third Generation (512)

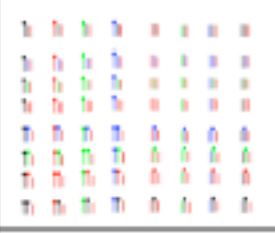
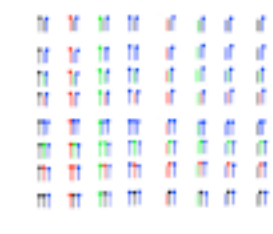
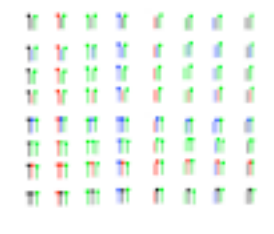
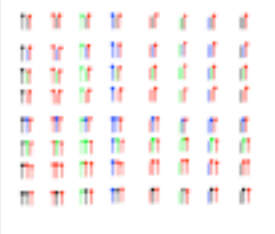
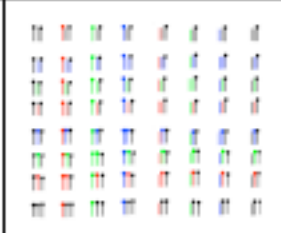
#### Tau Neutrino (1)

Rule: a Triple belongs to the Tau Neutrino if:  
All elements are Colorless (black)  
and all elements are Associative  
(that is, is 1 which is the only Colorless Associative element)

#### Tauon (7)

Rule: a Triple belongs to the Tauon if:  
All elements are Colorless (black)  
and at least one element is NonAssociative (that is, is E which is the only Colorless NonAssociative element)

Blue Beauty Quark (7)

Rule: a Triple belongs to the Blue Beauty Quark if:  
 There is at least one Blue element and all other elements are Blue or Colorless (black)  
 and all elements are Associative (that is, is either 1 or i or j or k).

Blue Truth Quark (161)

- Rules: a Triple belongs to the Blue Truth Quark if:
- 1 - There is at least one Blue element and all other elements are Blue or Colorless (black)  
 and at least one element is NonAssociative (that is, is either E or I or J or K)
  - 2 - There is one Red element and one Green element and the other element is Colorless (Red x Green = Blue)
  - 3 - The Triple has one element each that is Red, Green, or Blue, in which case the color of the Third element (for Third Generation) is determinative and must be Blue.

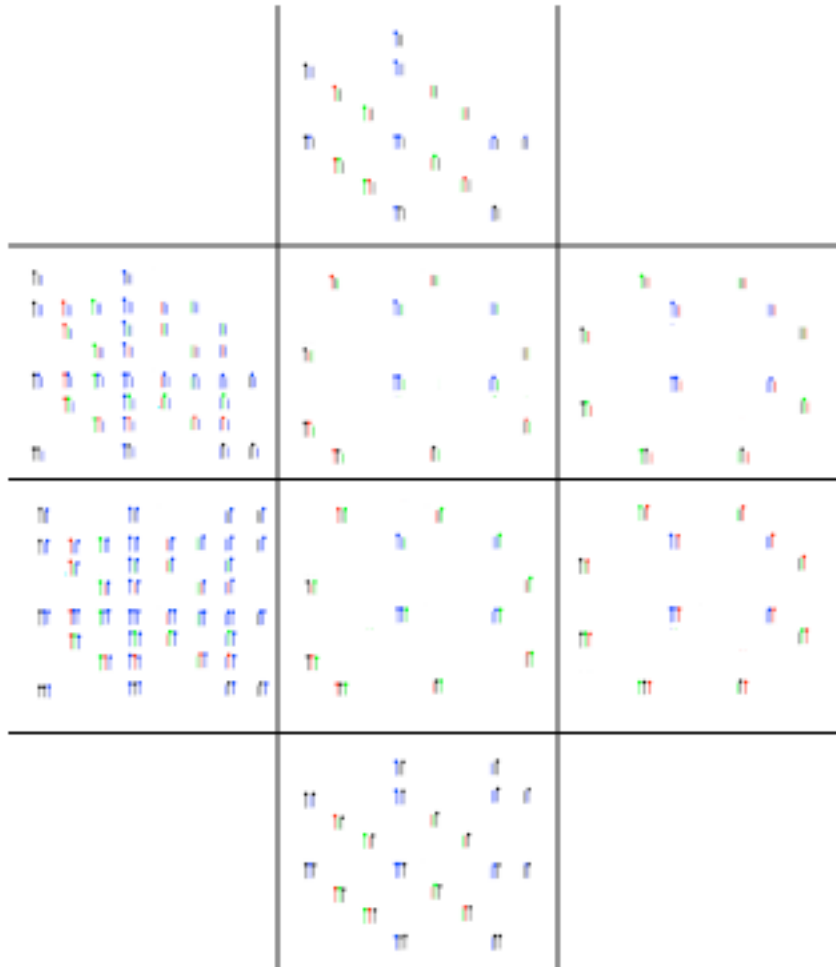

( Red and Green Beauty and Truth Quarks follow similar rules )



**The first generation** down quark constituent mass : electron mass ratio is:

The electron, E, can only be taken into the tree-level-massless neutrino, 1, by photon, weak boson, and gluon interactions.

The electron and neutrino, or their antiparticles, cannot be combined to produce any of the massive up or down quarks.

The neutrino, being massless at tree level, does not add anything to the mass formula for the electron.

Since the electron cannot be related to any other massive Dirac fermion, its volume  $V(Q_{\text{electron}})$  is taken to be 1.

Next consider a red down quark i.

By gluon interactions, i can be taken into j and k, the blue and green down quarks.

By also using weak boson interactions,

it can also be taken into I, J, and K, the red, blue, and green up quarks.

Given the up and down quarks, pions can be formed from quark-antiquark pairs, and the pions can decay to produce electrons and neutrinos.

Therefore the red down quark (similarly, any down quark)

is related to all parts of  $S^7 \times RP^1$ ,

the compact manifold corresponding to  $\{ 1, i, j, k, E, I, J, K \}$

and therefore

a down quark should have

a spinor manifold volume factor  $V(Q_{\text{down quark}})$  of the volume of  $S^7 \times RP^1$ .

The ratio of the down quark spinor manifold volume factor

to the electron spinor manifold volume factor is

$$V(Q_{\text{down quark}}) / V(Q_{\text{electron}}) = V(S^7 \times RP^1) / 1 = \pi^5 / 3.$$

Since the first generation graviton factor is 6,

$$m_d / m_e = 6 V(S^7 \times RP^1) = 2 \pi^5 = 612.03937$$

As the up quarks correspond to I, J, and K, which are the octonion transforms under E of i, j, and k of the down quarks, the up quarks and down quarks have the same constituent mass

$$m_u = m_d.$$

Antiparticles have the same mass as the corresponding particles.

Since the model only gives ratios of masses,

the mass scale is fixed so that the electron mass  $m_e = 0.5110 \text{ MeV}$ .

Then, the constituent mass of the down quark is  $m_d = 312.75 \text{ MeV}$ ,

and the constituent mass for the up quark is  $m_u = 312.75 \text{ MeV}$ .

These results when added up give a total mass of first generation fermion particles:

$$\mathbf{\Sigma_{mf1} = 1.877 \text{ GeV}}$$

As the proton mass is taken to be the sum of the constituent masses of its constituent quarks

$$m_{\text{proton}} = m_u + m_u + m_d = 938.25 \text{ MeV}$$

which is close to the experimental value of 938.27 MeV.

**The third generation** fermion particles correspond to triples of octonions. There are  $8^3 = 512$  such triples.

The triple  $\{ 1, 1, 1 \}$  corresponds to the tau-neutrino.

The other 7 triples involving only 1 and E correspond to the tauon:

$\{ E, E, E \}$   
 $\{ E, E, 1 \}$   
 $\{ E, 1, E \}$   
 $\{ 1, E, E \}$   
 $\{ 1, 1, E \}$   
 $\{ 1, E, 1 \}$   
 $\{ E, 1, 1 \}$

The symmetry of the 7 tauon triples is the same as the symmetry of the first generation tree-level-massive fermions, 3 down, quarks, the 3 up quarks, and the electron, so by the Sym factor the tauon mass should be the same as the sum of the masses of the first generation massive fermion particles.

Therefore the tauon mass is calculated at tree level as 1.877 GeV.

The calculated tauon mass of 1.88 GeV is a sum of first generation fermion masses, all of which are valid at the energy level of about 1 GeV.

However, as the tauon mass is about 2 GeV, the effective tauon mass should be renormalized from the energy level of 1 GeV at which the mass is 1.88 GeV to the energy level of 2 GeV. Such a renormalization should reduce the mass.

If the renormalization reduction were about 5 percent, the effective tauon mass at 2 GeV would be about 1.78 GeV. The 1996 Particle Data Group Review of Particle Physics gives a tauon mass of 1.777 GeV.

All triples corresponding to the tau and the tau-neutrino are colorless.

The beauty quark corresponds to 21 triples.  
They are triples of the same form as the 7 tauon triples involving 1 and E,  
but for 1 and I, 1 and J, and 1 and K,  
which correspond to the red, green, and blue beauty quarks,  
respectively.

The seven red beauty quark triples correspond to the seven tauon triples,  
except that  
the beauty quark interacts with 6 Spin(0,5) gravitons  
while the tauon interacts with only two.

The red beauty quark constituent mass should be the tauon mass times  
the third generation graviton factor  $6/2 = 3$ ,  
so the red beauty quark mass is  $m_b = 5.63111$  GeV.

The blue and green beauty quarks are similarly determined to also be 5.63111 GeV.

The calculated beauty quark mass of 5.63 GeV is a constituent mass,  
that is, it corresponds to the conventional pole mass plus 312.8 MeV.  
Therefore, the calculated beauty quark mass of 5.63 GeV  
corresponds to a conventional pole mass of 5.32 GeV.

The 1996 Particle Data Group Review of Particle Physics gives  
a lattice gauge theory beauty quark pole mass as 5.0 GeV.

The pole mass can be converted to an MSbar mass  
if the color force strength constant  $\alpha_s$  is known.  
The conventional value of  $\alpha_s$  at about 5 GeV is about 0.22.

Using  $\alpha_s(5 \text{ GeV}) = 0.22$ , a pole mass of 5.0 GeV  
gives an MSbar 1-loop beauty quark mass of 4.6 GeV,  
and  
an MSbar 1,2-loop beauty quark mass of 4.3, evaluated at about 5 GeV.

If the MSbar mass is run from 5 GeV up to 90 GeV,  
the MSbar mass decreases by about 1.3 GeV,  
giving an expected MSbar mass of about 3.0 GeV at 90 GeV.

DELPHI at LEP has observed the Beauty Quark  
and found a 90 GeV MSbar beauty quark mass of about 2.67 GeV,  
with error bars  $\pm 0.25$  (stat)  $\pm 0.34$  (frag)  $\pm 0.27$  (theo).

The theoretical model calculated Beauty Quark mass of 5.63 GeV corresponds to a pole mass of 5.32 GeV, which is somewhat higher than the conventional value of 5.0 GeV.

However, the theoretical model calculated value of the color force strength constant  $\alpha_s$  at about 5 GeV is about 0.166, while the conventional value of the color force strength constant  $\alpha_s$  at about 5 GeV is about 0.216, and the theoretical model calculated value of the color force strength constant  $\alpha_s$  at about 90 GeV is about 0.106, while the conventional value of the color force strength constant  $\alpha_s$  at about 90 GeV is about 0.118.

The theoretical model calculations gives a Beauty Quark pole mass (5.3 GeV) that is about 6 percent higher than the conventional Beauty Quark pole mass (5.0 GeV), and a color force strength  $\alpha_s$  at 5 GeV (0.166) such that  $1 + \alpha_s = 1.166$  is about 4 percent lower than the conventional value of  $1 + \alpha_s = 1.216$  at 5 GeV.

Triples of the type  $\{ 1, I, J \}$ ,  $\{ I, J, K \}$ , etc., do not correspond to the beauty quark, but to the truth quark. The truth quark corresponds to those  $512 - 1 - 7 - 21 = 483$  triples, so the constituent mass of the red truth quark is  $161 / 7 = 23$  times the red beauty quark mass, and the red T-quark mass is  $m_t = 129.5155$  GeV

The blue and green truth quarks are similarly determined to also be 129.5155 GeV.

This is the value of the Low Mass State of the Truth calculated in the Cl(1,25) E8 model. The Middle Mass State of the Truth Quark has been observed by Fermilab since 1994. The Low and High Mass States of the Truth Quark have, in my opinion, also been observed by Fermilab (see Chapter 17 of this paper) but the Fermilab and CERN establishments disagree.

All other masses than the electron mass (which is the basis of the assumption of the value of the Higgs scalar field vacuum expectation value  $v = 252.514$  GeV), including the Higgs scalar mass and Truth quark mass, are calculated (not assumed) masses in the Cl(1,25) E8 model. These results when added up give a total mass of third generation fermion particles:

$$\mathbf{\Sigma_{maf3} = 1,629 \text{ GeV}}$$

**The second generation** fermion particles correspond to pairs of octonions.  
There are  $8^2 = 64$  such pairs.

The pair  $\{ 1, 1 \}$  corresponds to the mu-neutrino.

The pairs  $\{ 1, E \}$ ,  $\{ E, 1 \}$ , and  $\{ E, E \}$  correspond to the muon.

For the Sym factor, compare the symmetries of the muon pairs to the symmetries of the first generation fermion particles:  
The pair  $\{ E, E \}$  should correspond to the E electron.  
The other two muon pairs have a symmetry group  $S_2$ , which is  $1/3$  the size of the color symmetry group  $S_3$  which gives the up and down quarks their mass of 312.75 MeV.

Therefore the mass of the muon should be the sum of the  $\{ E, E \}$  electron mass and the  $\{ 1, E \}$ ,  $\{ E, 1 \}$  symmetry mass, which is  $1/3$  of the up or down quark mass. Therefore,  $m_{\mu} = 104.76$  MeV .

According to the 1998 Review of Particle Physics of the Particle Data Group, the experimental muon mass is about 105.66 MeV which may be consistent with radiative corrections for the calculated tree-level  $m_{\mu} = 104.76$  MeV as Bailin and Love, in "Introduction to Gauge Field Theory", IOP (rev ed 1993), say: "... considering the order alpha radiative corrections to muon decay ... Numerical details are contained in Sirlin ... 1980 Phys. Rev. D 22 971 ... who concludes that the order alpha corrections have the effect of increasing the decay rate about 7% compared with the tree graph prediction ...". Since the decay rate is proportional to  $m_{\mu}^5$  the corresponding effective increase in muon mass would be about 1.36%, which would bring 104.8 MeV up to about 106.2 MeV.

All pairs corresponding to the muon and the mu-neutrino are colorless.

The red, blue and green strange quark each corresponds to the 3 pairs involving 1 and i, j, or k.

The red strange quark is defined as the three pairs  $\{ 1, i \}$ ,  $\{ i, 1 \}$ ,  $\{ i, i \}$  because i is the red down quark.

Its mass should be the sum of two parts:

the  $\{ i, i \}$  red down quark mass, 312.75 MeV, and

the product of the symmetry part of the muon mass, 104.25 MeV, times the graviton factor.

Unlike the first generation situation, massive second and third generation leptons can be taken, by both of the colorless gravitons that may carry electric charge, into massive particles.

Therefore the graviton factor for the second and third generations is  $6/2 = 3$ .

So the symmetry part of the muon mass times the graviton factor 3 is 312.75 MeV, and the red strange quark constituent mass is  $m_s = 312.75 \text{ MeV} + 312.75 \text{ MeV} = 625.5 \text{ MeV}$

The blue strange quarks correspond to the three pairs involving j, the green strange quarks correspond to the three pairs involving k, and their masses are similarly determined to also be 625.5 MeV.

The charm quark corresponds to the remaining  $64 - 1 - 3 - 9 = 51$  pairs.

Therefore, the mass of the red charm quark should be the sum of two parts:

the  $\{ i, i \}$ , red up quark mass, 312.75 MeV;

and

the product of the symmetry part of the strange quark mass, 312.75 MeV,

and the charm to strange octonion number factor  $51 / 9$ ,

which product is 1,772.25 MeV.

Therefore the red charm quark constituent mass is

$$m_c = 312.75 \text{ MeV} + 1,772.25 \text{ MeV} = 2.085 \text{ GeV}$$

The blue and green charm quarks are similarly determined to also be 2.085 GeV.

The calculated Charm Quark mass of 2.09 GeV is a constituent mass, that is, it corresponds to the conventional pole mass plus 312.8 MeV.

Therefore, the calculated Charm Quark mass of 2.09 GeV corresponds to a conventional pole mass of 1.78 GeV.

The 1996 Particle Data Group Review of Particle Physics gives a range for the Charm Quark pole mass from 1.2 to 1.9 GeV.

The pole mass can be converted to an MSbar mass if the color force strength constant  $\alpha_s$  is known.

The conventional value of  $\alpha_s$  at about 2 GeV is about 0.39, which is somewhat lower than the theoretical model value.

Using  $\alpha_s(2 \text{ GeV}) = 0.39$ , a pole mass of 1.9 GeV gives an MSbar 1-loop mass of 1.6 GeV, evaluated at about 2 GeV.

These results when added up give a total mass of second generation fermion particles:

$$\mathbf{\Sigma_{f2} = 32.9 \text{ GeV}}$$

## Kobayashi-Maskawa Parameters

In E8 Physics the KM Unitarity Triangle angles can be seen on the Stella Octangula

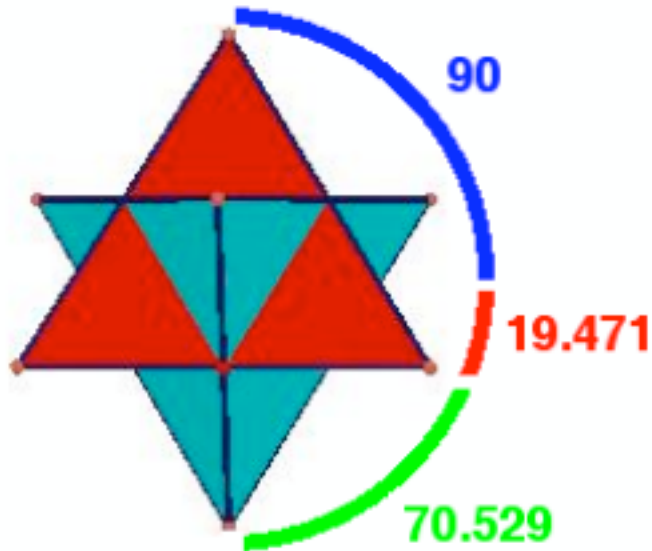

The Kobayashi-Maskawa parameters are determined in terms of the sum of the masses of the 30 first-generation fermion particles and antiparticles, denoted by

$$S_{mf1} = 7.508 \text{ GeV},$$

and the similar sums for second-generation and third-generation fermions, denoted by

$$S_{mf2} = 32.94504 \text{ GeV} \text{ and } S_{mf3} = 1,629.2675 \text{ GeV}.$$

The resulting KM matrix is:

d		s	b
u	0.975	0.222 0.00249	-0.00388i
c	-0.222 -0.000161i	0.974 -0.0000365i	0.0423
t	0.00698 -0.00378i	-0.0418 -0.00086i	0.999



**Below the energy level of ElectroWeak Symmetry Breaking  
the Higgs mechanism gives mass to particles.**

According to a Review on the Kobayashi-Maskawa mixing matrix by Ceccucci, Ligeti, and Sakai in the 2010 Review of Particle Physics (note that I have changed their terminology of CKM matrix to the KM terminology that I prefer because I feel that it was Kobayashi and Maskawa, not Cabibbo, who saw that 3x3 was the proper matrix structure): "... the charged-current  $W_{\pm}$  interactions couple to the ... quarks with couplings given by ...

$$\begin{matrix} V_{ud} & V_{us} & V_{ub} \\ V_{cd} & V_{cs} & V_{cb} \\ V_{td} & V_{ts} & V_{tb} \end{matrix}$$

This Kobayashi-Maskawa (KM) matrix is a 3x3 unitary matrix. It can be parameterized by three mixing angles and the CP-violating KM phase ... The most commonly used unitarity triangle arises from  $V_{ud} V_{ub}^* + V_{cd} V_{cb}^* + V_{td} V_{tb}^* = 0$ , by dividing each side by the best-known one,  $V_{cd} V_{cb}^*$

...  $\bar{\rho} + i\bar{\eta} = -(V_{ud} V_{ub}^*) / (V_{cd} V_{cb}^*)$  is phase-convention-independent ...

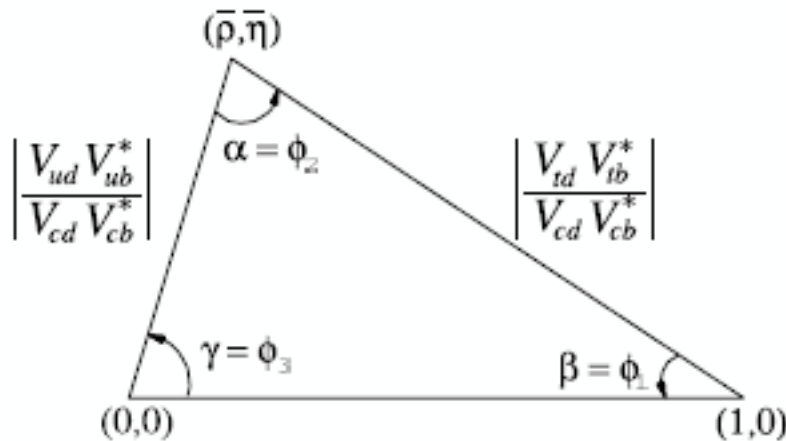
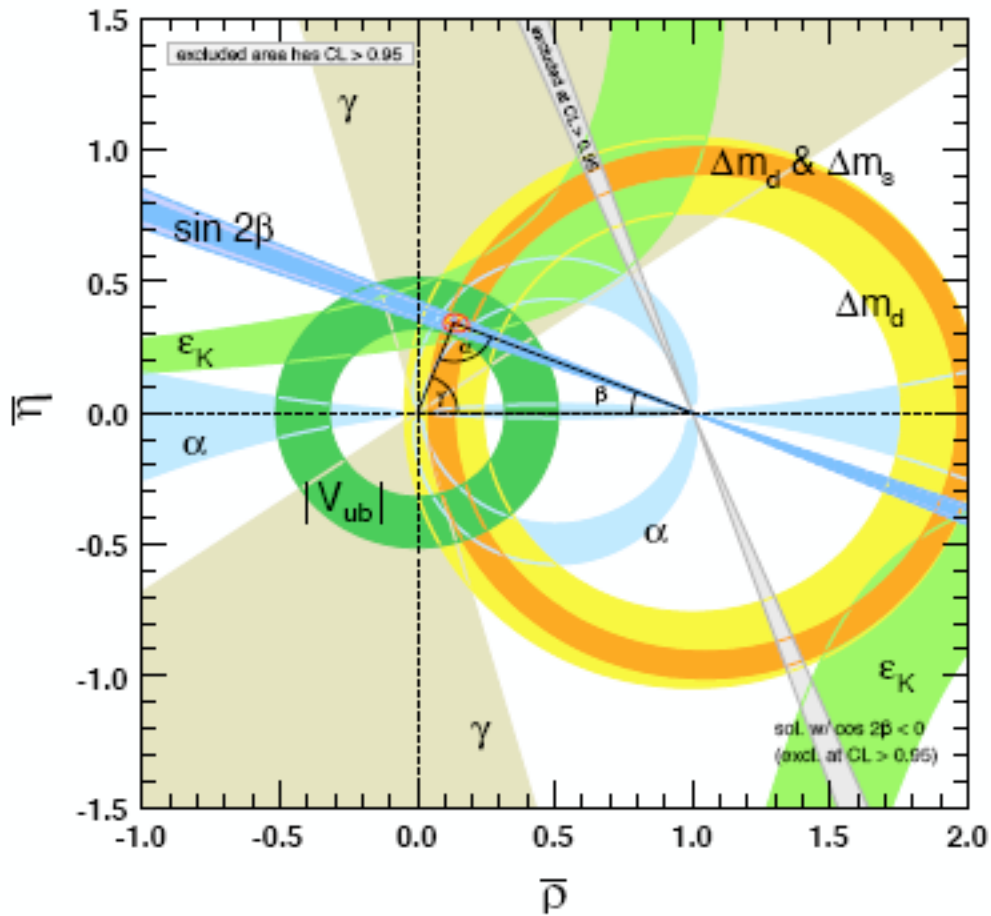

Figure 11.1: Sketch of the unitarity triangle.

...  $\sin 2\beta = 0.673 \pm 0.023$  ...  $\alpha = 89.0 + 4.4 - 4.2$  degrees ...  $\gamma = 73 + 22 - 25$  degrees ... The sum of the three angles of the unitarity triangle,  $\alpha + \beta + \gamma = (183 + 22 - 25)$  degrees, is ... consistent with the SM expectation. ...

The area... of ...[the]... triangle...[is]... half of the Jarlskog invariant,  $J$ , which is a phase-convention-independent measure of CP violation, defined by  $\text{Im } V_{ij} V_{kl} V_{il}^* V_{kj}^* = J \sum_{(m,n)} \epsilon_{ikm} \epsilon_{jln}$



**Figure 11.2:** Constraints on the  $\bar{\rho}, \bar{\eta}$  plane.  
The shaded areas have 95% CL.

The fit results for the magnitudes of all nine KM elements are ...

$0.97428 \pm 0.00015$	$0.2253 \pm 0.0007$	$0.00347 +0.00016 -0.00012$
$0.2252 \pm 0.0007$	$0.97345 +0.00015 -0.00016$	$0.0410 +0.0011 -0.0007$
$0.00862 +0.00026 -0.00020$	$0.0403 +0.0011 -0.0007$	$0.999152 +0.000030 -0.000045$

and the Jarlskog invariant is  $J = (2.91 +0.19 -0.11) \times 10^{-5}$ . ...".

**Above the energy level of ElectroWeak Symmetry Breaking  
particles are massless.**

Kea (Marni Sheppeard) proposed  
that in the Massless Realm the mixing matrix might be democratic.  
In Z. Phys. C - Particles and Fields 45, 39-41 (1989) Koide said: "...  
the mass matrix ... MD ... of the type ...  $1/3 \times m \times$

$$\begin{matrix} 1 & 1 & 1 \\ 1 & 1 & 1 \\ 1 & 1 & 1 \end{matrix}$$

... has name... "democratic" family mixing ...  
the ... democratic ... mass matrix can be diagonalized by the transformation matrix A ...

$$\begin{matrix} 1/\sqrt{2} & -1/\sqrt{2} & 0 \\ 1/\sqrt{6} & 1/\sqrt{6} & -2/\sqrt{6} \\ 1/\sqrt{3} & 1/\sqrt{3} & 1/\sqrt{3} \end{matrix}$$

as  $A M D A^t =$

$$\begin{matrix} 0 & 0 & 0 \\ 0 & 0 & 0 \\ 0 & 0 & m \end{matrix}$$

...".

Up in the Massless Realm you might just say that there is no mass matrix,  
just a democratic mixing matrix of the form  $1/3 \times$

$$\begin{matrix} 1 & 1 & 1 \\ 1 & 1 & 1 \\ 1 & 1 & 1 \end{matrix}$$

with no complex stuff and no CP violation in the Massless Realm.

When go down to our Massive Realm by ElectroWeak Symmetry Breaking  
then you might as a first approximation use  $m = 1$   
so that all the mass first goes to the third generation as

$$\begin{matrix} 0 & 0 & 0 \\ 0 & 0 & 0 \\ 0 & 0 & 1 \end{matrix}$$

which is physically like the Higgs being a T-Tbar quark condensate.

Consider a 3-dim Euclidean space of generations:

The case of mass only going to one generation  
can be represented as a line or 1-dimensional simplex



in which the blue mass-line covers the entire black simplex line.

If mass only goes to one other generation  
that can be represented by a red line extending to a second dimension  
forming a small blue-red-black triangle

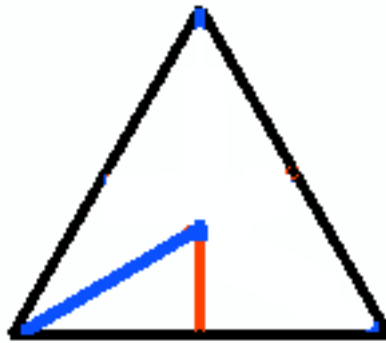

that can be extended by reflection to form six small triangles making up a large triangle

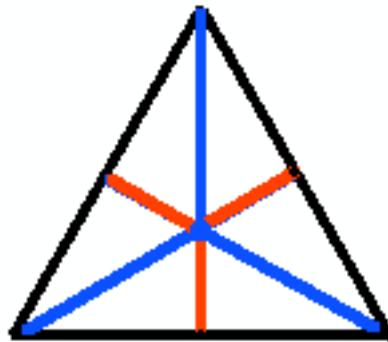

Each of the six component triangles has 30-60-90 angle structure:



If mass goes on further to all three generations  
that can be represented by a green line extending to a third dimension

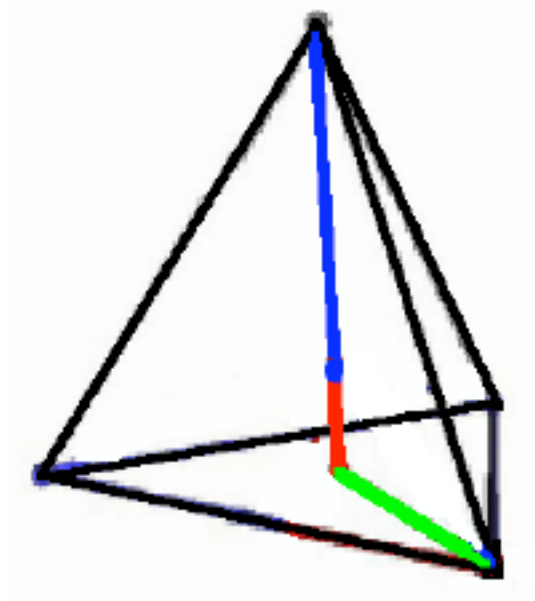

If you move the blue line from the top vertex to join the green vertex

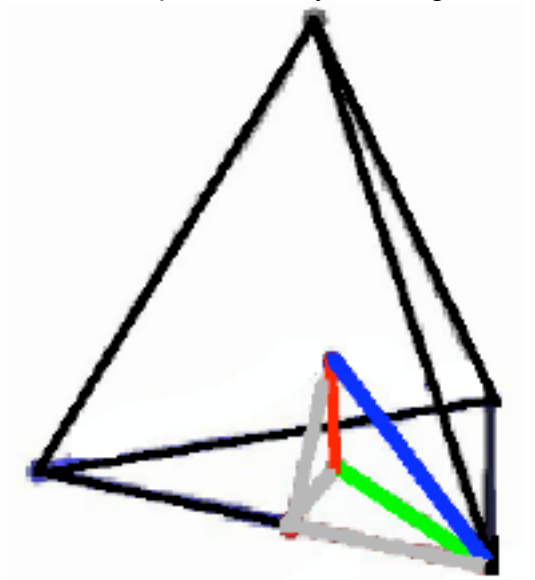

you get a small blue-red-green-gray-gray tetrahedron  
that can be extended by reflection to form 24 small tetrahedra  
making up a large tetrahedron.

Reflection among the 24 small tetrahedra corresponds  
to the  $12+12 = 24$  elements of the Binary Tetrahedral Group.

The basic blue-red-green triangle of the basic small tetrahedron

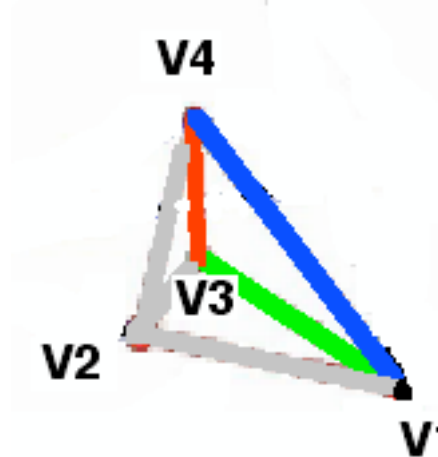

has the angle structure of the K-M Unitary Triangle.

Using data from R. W. Gray's "Encyclopedia Polyhedra: A Quantum Module" with lengths

$V1.V2 = (1/2) EL \equiv$  Half of the regular Tetrahedron's edge length.

$V1.V3 = (1 / \sqrt{3}) EL \approx 0.577\ 350\ 269 EL$

$V1.V4 = 3 / (2 \sqrt{6}) EL \approx 0.612\ 372\ 436 EL$

$V2.V3 = 1 / (2 \sqrt{3}) EL \approx 0.288\ 675\ 135 EL$

$V2.V4 = 1 / (2 \sqrt{2}) EL \approx 0.353\ 553\ 391 EL$

$V3.V4 = 1 / (2 \sqrt{6}) EL \approx 0.204\ 124\ 145 EL$

the Unitarity Triangle angles are:

$\beta = V3.V1.V4 = \arccos(2 \sqrt{2} / 3) \approx 19.471\ 220\ 634$  degrees so  $\sin 2\beta = 0.6285$

$\alpha = V1.V3.V4 = 90$  degrees

$\gamma = V1.V4.V3 = \arcsin(2 \sqrt{2} / 3) \approx 70.528\ 779\ 366$  degrees

which is substantially consistent with the 2010 Review of Particle Properties

$\sin 2\beta = 0.673 \pm 0.023$  so  $\beta = 21.1495$  degrees

$\alpha = 89.0 +4.4 -4.2$  degrees

$\gamma = 73 +22 -25$  degrees

and so also consistent with the Standard Model expectation.

The constructed Unitarity Triangle angles can be seen on the Stella Octangula configuration of two dual tetrahedra (image from gauss.math.nthu.edu.tw):

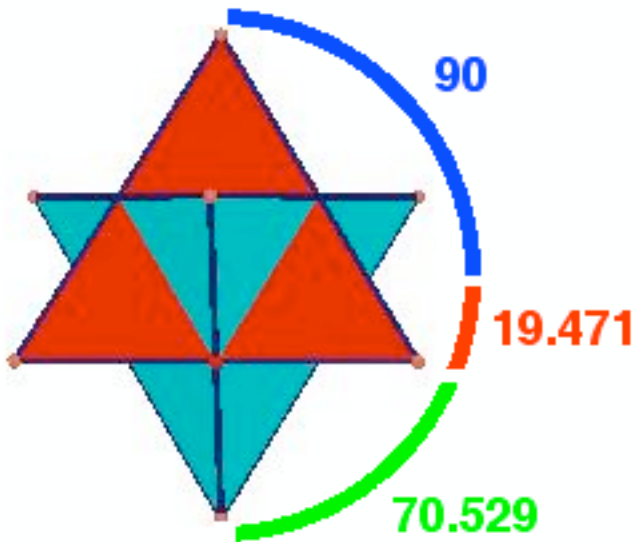

In the  $Cl(1,25)$   $E_8$  model the Kobayashi-Maskawa parameters are determined in terms of the sum of the masses of the 30 first-generation fermion particles and antiparticles, denoted by  $S_{mf1} = 7.508$  GeV,

and the similar sums for second-generation and third-generation fermions, denoted by  $S_{mf2} = 32.94504$  GeV and  $S_{mf3} = 1,629.2675$  GeV.

The reason for using sums of all fermion masses (rather than sums of quark masses only) is that all fermions are in the same spinor representation of  $Spin(8)$ , and the  $Spin(8)$  representations are considered to be fundamental.

The following formulas use the above masses to calculate Kobayashi-Maskawa parameters:

phase angle  $d_{13} = \gamma = 70.529$  degrees

$$\sin(\theta_{12}) = s_{12} = [m_e + 3m_d + 3m_\mu] / \sqrt{[m_e^2 + 3m_d^2 + 3m_\mu^2] + [3m_\nu^2 + 3m_s^2 + 3m_c^2]} = 0.222198$$

$$\sin(\theta_{13}) = s_{13} = [m_e + 3m_d + 3m_\mu] / \sqrt{[m_e^2 + 3m_d^2 + 3m_\mu^2] + [3m_\nu^2 + 3m_b^2 + 3m_t^2]} = 0.004608$$

$$\sin(\theta_{23}) = [3m_\nu + 3m_s + 3m_c] / \sqrt{[3m_\nu^2 + 3m_b^2 + 3m_t^2] + [3m_\nu^2 + 3m_s^2 + 3m_c^2]}$$

$$\sin(\theta_{23}) = s_{23} = \sin(\theta_{23}) \sqrt{(\sigma_{f2} / \sigma_{f1})} = 0.04234886$$

The factor  $\sqrt{(\sigma_{f2} / \sigma_{f1})}$  appears in  $s_{23}$  because an  $s_{23}$  transition is to the second generation and not all the way to the first generation, so that the end product of an  $s_{23}$  transition has a greater available energy than  $s_{12}$  or  $s_{13}$  transitions by a factor of  $\sigma_{f2} / \sigma_{f1}$ .

Since the width of a transition is proportional to the square of the modulus of the relevant KM entry and the width of an  $s_{23}$  transition has greater available energy than the  $s_{12}$  or  $s_{13}$  transitions by a factor of  $\sigma_{f2} / \sigma_{f1}$  the effective magnitude of the  $s_{23}$  terms in the KM entries is increased by the factor  $\sqrt{(\sigma_{f2} / \sigma_{f1})}$ .

The Chau-Keung parameterization is used, as it allows the K-M matrix to be represented as the product of the following three 3x3 matrices:

$$\begin{pmatrix} 1 & 0 & 0 \\ 0 & \cos(\theta_{23}) & \sin(\theta_{23}) \\ 0 & -\sin(\theta_{23}) & \cos(\theta_{23}) \end{pmatrix}$$

$$\begin{pmatrix} \cos(\theta_{13}) & 0 & \sin(\theta_{13})\exp(-i d_{13}) \\ 0 & 1 & 0 \\ -\sin(\theta_{13})\exp(i d_{13}) & 0 & \cos(\theta_{13}) \end{pmatrix}$$

$$\begin{pmatrix} \cos(\theta_{12}) & \sin(\theta_{12}) & 0 \\ -\sin(\theta_{12}) & \cos(\theta_{12}) & 0 \\ 0 & 0 & 1 \end{pmatrix}$$



The resulting Kobayashi-Maskawa parameters  
for  $W^+$  and  $W^-$  charged weak boson processes, are:

	d	s	b
u	0.975	0.222	0.00249 -0.00388i
c	-0.222 -0.000161i	0.974 -0.0000365i	0.0423
t	0.00698 -0.00378i	-0.0418 -0.00086i	0.999

The matrix is labelled by either (u c t) input and (d s b) output,  
or, as above, (d s b) input and (u c t) output.

For  $Z^0$  neutral weak boson processes, which are suppressed by the GIM  
mechanism of cancellation of virtual subprocesses, the matrix is labelled by either  
(u c t) input and (u'c't') output, or, as below, (d s b) input and (d's'b') output:

	d	s	b
d'	0.975	0.222	0.00249 -0.00388i
s'	-0.222 -0.000161i	0.974 -0.0000365i	0.0423
b'	0.00698 -0.00378i	-0.0418 -0.00086i	0.999

Since neutrinos of all three generations are massless at tree level,  
the lepton sector has no tree-level K-M mixing.

In hep-ph/0208080, Yosef Nir says: "... Within the Standard Model,  
the only source of CP violation is the Kobayashi-Maskawa (KM) phase ...  
The study of CP violation is, at last, experiment driven. ...  
The CKM matrix provides a consistent picture  
of all the measured flavor and CP violating processes. ...  
There is no signal of new flavor physics. ...  
Very likely,  
the KM mechanism is the dominant source of CP violation in flavor changing processes.  
... The result is consistent with the SM predictions. ...".

## Neutrino Masses Beyond Tree Level

Consider the three generations of neutrinos:  
nu\_e (electron neutrino); nu\_m (muon neutrino); nu\_t  
and three neutrino mass states: nu\_1 ; nu\_2 : nu\_3  
and  
the division of 8-dimensional spacetime into  
4-dimensional physical Minkowski spacetime  
plus  
4-dimensional CP2 internal symmetry space.

The heaviest mass state nu\_3 corresponds to a neutrino  
whose propagation begins and ends in CP2 internal symmetry  
space, lying entirely therein. According to the Cl(1,25) E8 model  
the mass of nu\_3 is zero at tree-level  
but it picks up a first-order correction  
propagating entirely through internal symmetry space by merging  
with an electron through the weak and electromagnetic forces,  
effectively acting not merely as a point  
but  
as a point plus an electron loop at beginning and ending points  
so  
the first-order corrected mass of nu\_3 is given by  
 $M_{\nu_3} \times (1/\sqrt{2}) = M_e \times GW(m_{\text{proton}}^2) \times \alpha_E$   
where the factor  $(1/\sqrt{2})$  comes from the Ut3 component  
of the neutrino mixing matrix  
so that

$$\begin{aligned} M_{\nu_3} &= \sqrt{2} \times M_e \times GW(m_{\text{proton}}^2) \times \alpha_E = \\ &= 1.4 \times 5 \times 10^5 \times 1.05 \times 10^{(-5)} \times (1/137) \text{ eV} = \\ &= 7.35 / 137 = 5.4 \times 10^{(-2)} \text{ eV}. \end{aligned}$$

The neutrino-plus-electron loop can be anchored by weak force  
action through any of the 6 first-generation quarks  
at each of the beginning and ending points, and that the  
anchor quark at the beginning point can be different from  
the anchor quark at the ending point,  
so that there are  $6 \times 6 = 36$  different possible anchorings.

The intermediate mass state  $\nu_2$  corresponds to a neutrino whose propagation begins or ends in CP2 internal symmetry space and ends or begins in M4 physical Minkowski spacetime, thus having only one point (either beginning or ending) lying in CP2 internal symmetry space where it can act not merely as a point but as a point plus an electron loop.

According to the Cl(1,25) E8 model the mass of  $\nu_2$  is zero at tree-level but it picks up a first-order correction at only one (but not both) of the beginning or ending points so that so that there are 6 different possible anchorings for  $\nu_2$  first-order corrections, as opposed to the 36 different possible anchorings for  $\nu_3$  first-order corrections, so that the first-order corrected mass of  $\nu_2$  is less than the first-order corrected mass of  $\nu_3$  by a factor of 6, so

the first-order corrected mass of  $\nu_2$  is  

$$M_{\nu_2} = M_{\nu_3} / \text{Vol}(\text{CP}2) = 5.4 \times 10^{(-2)} / 6$$

$$= 9 \times 10^{(-3)} \text{eV}.$$

The low mass state  $\nu_1$  corresponds to a neutrino whose propagation begins and ends in physical Minkowski spacetime. thus having only one anchoring to CP2 interna symmetry space.

According to the Cl(1,25) E8 model the mass of  $\nu_1$  is zero at tree-level but it has only 1 possible anchoring to CP2 as opposed to the 36 different possible anchorings for  $\nu_3$  first-order corrections or the 6 different possible anchorings for  $\nu_2$  first-order corrections so that the first-order corrected mass of  $\nu_1$  is less than the first-order corrected mass of  $\nu_2$  by a factor of 6, so

the first-order corrected mass of  $\nu_1$  is  

$$M_{\nu_1} = M_{\nu_2} / \text{Vol}(\text{CP}2) = 9 \times 10^{(-3)} / 6$$

$$= 1.5 \times 10^{(-3)} \text{eV}.$$

Therefore:

$$\begin{aligned} \text{the mass-squared difference } D(M_{23}^2) &= M_{\nu_3}^2 - M_{\nu_2}^2 = \\ &= (2916 - 81) \times 10^{(-6)} \text{ eV}^2 = \\ &= 2.8 \times 10^{(-3)} \text{ eV}^2 \end{aligned}$$

and

$$\begin{aligned} \text{the mass-squared difference } D(M_{12}^2) &= M_{\nu_2}^2 - M_{\nu_1}^2 = \\ &= (81 - 2) \times 10^{(-6)} \text{ eV}^2 = \\ &= 7.9 \times 10^{(-5)} \text{ eV}^2 \end{aligned}$$

The 3x3 unitary neutrino mixing matrix neutrino mixing matrix U

	nu_1	nu_2	nu_3
nu_e	Ue1	Ue2	Ue3
nu_m	Um1	Um2	Um3
nu_t	Ut1	Ut2	Ut3

can be parameterized (based on the 2010 Particle Data Book)  
by 3 angles and 1 Dirac CP violation phase

$$U = \begin{pmatrix} c_{12} c_{13} & s_{12} c_{13} & s_{13} e^{-i\delta} \\ -s_{12} c_{23} - c_{12} s_{23} s_{13} e^{i\delta} & c_{12} c_{23} - s_{12} s_{23} s_{13} e^{i\delta} & s_{23} c_{13} \\ s_{12} s_{23} - c_{12} c_{23} s_{13} e^{i\delta} & -c_{12} s_{23} - s_{12} c_{23} s_{13} e^{i\delta} & c_{23} c_{13} \end{pmatrix}$$

where  $c_{ij} = \cos(\theta_{ij})$  ,  $s_{ij} = \sin(\theta_{ij})$

The angles are

$\theta_{23} = \pi/4 = 45$  degrees

because

$\nu_3$  has equal components of  $\nu_m$  and  $\nu_t$  so  
that  $U_{m3} = U_{t3} = 1/\sqrt{2}$  or, in conventional  
notation, mixing angle  $\theta_{23} = \pi/4$

so that  $\cos(\theta_{23}) = 0.707 = \sqrt{2}/2 = \sin(\theta_{23})$

$\theta_{13} = 9.594$  degrees =  $\arcsin(1/6)$

and  $\cos(\theta_{13}) = 0.986$

because  $\sin(\theta_{13}) = 1/6 = 0.167 = |U_{e3}|$  = fraction of  $\nu_3$  that is  $\nu_e$

$\theta_{12} = \pi/6 = 30$  degrees

because

$\sin(\theta_{12}) = 0.5 = 1/2 = U_{e2}$  = fraction of  $\nu_2$  begin/end points  
that are in the physical spacetime where massless  $\nu_e$  lives

so that  $\cos(\theta_{12}) = 0.866 = \sqrt{3}/2$

$\delta = 70.529$  degrees is the Dirac CP violation phase

$e^{i(70.529)} = \cos(70.529) + i \sin(70.529) = 0.333 + 0.943 i$

This is because the neutrino mixing matrix has 3-generation structure  
and so has the same phase structure as the KM quark mixing matrix  
in which the Unitarity Triangle angles are:

$\beta = V_3.V_1.V_4 = \arccos( 2 \sqrt{2} / 3 ) \cong 19.471 220 634$  degrees so  $\sin 2\beta = 0.6285$

$\alpha = V_1.V_3.V_4 = 90$  degrees

$\gamma = V_1.V_4.V_3 = \arcsin( 2 \sqrt{2} / 3 ) \cong 70.528 779 366$  degrees

The constructed Unitarity Triangle angles can be seen on the Stella Octangula configuration of two dual tetrahedra (image from [gauss.math.nthu.edu.tw](http://gauss.math.nthu.edu.tw)):

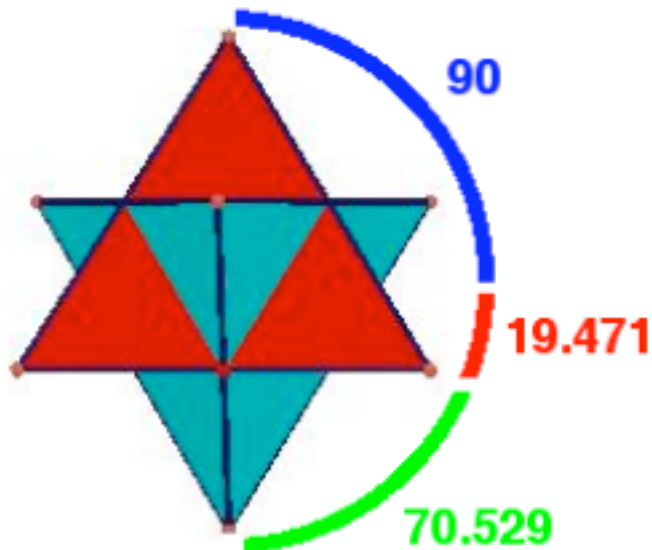

Then we have for the neutrino mixing matrix:

	nu_1	nu_2	nu_3
nu_e	0.866 x 0.986	0.50 x 0.986	0.167 x e-id
nu_m	-0.5 x 0.707 -0.866 x 0.707 x 0.167 x eid	0.866 x 0.707 -0.5 x 0.707 x 0.167 x eid	0.707 x 0.986
nu_t	0.5 x 0.707 -0.866 x 0.707 x 0.167 x eid	-0.866 x 0.707 -0.5 x 0.707 x 0.167 x eid	0.707 x 0.986

	nu_1	nu_2	nu_3
nu_e	0.853	0.493	0.167 e-id
nu_m	-0.354 -0.102 eid	0.612 -0.059 eid	0.697
nu_t	0.354 -0.102 eid	-0.612 -0.059 eid	0.697

Since  $e^{i(70.529)} = \cos(70.529) + i \sin(70.529) = 0.333 + 0.943 i$   
and  $.333e^{-i(70.529)} = \cos(70.529) - i \sin(70.529) = 0.333 - 0.943 i$

	nu_1	nu_2	nu_3
nu_e	0.853	0.493	0.056 - 0.157 i
nu_m	-0.354 -0.034 - 0.096 i	0.612 -0.020 - 0.056 i	0.697
nu_t	0.354 -0.034 - 0.096 i	-0.612 -0.020 - 0.056 i	0.697

for a result of

	nu_1	nu_2	nu_3
nu_e	0.853	0.493	0.056 - 0.157 i
nu_m	-0.388 - 0.096 i	0.592 - 0.056 i	0.697
nu_t	0.320 - 0.096 i	0.632 - 0.056 i	0.697

which is consistent with the approximate experimental values of mixing angles shown in the Michaelmas Term 2010 Particle Physics handout of Prof Mark Thomson if the matrix is modified by taking into account the March 2012 results from Daya Bay observing non-zero  $\theta_{13} = 9.54$  degrees.

## Photon

The Standard Model U(1) Electromagnetic Force bosons (photons) live in a U(1) subalgebra of the U(2) local group of  $CP^2 = SU(3) / U(2)$   
They "see" M4 Physical spacetime as four 1-sphere circles  $S^1 \times S^1 \times S^1 \times S^1 = T^4$   
( $T^4 = 4$ -torus) each of whose dimension is 1 and has volume  $2\pi$

Their part of the Physical Lagrangian is

$\int_{T^4} (\text{U(1) Electromagnetism Gauge Boson Term})$   
an integral over SpaceTime  $T^4$ .

Schwinger Source for U(1) photons that carry no charge,  
so the Complex Bounded Domains and Shilov Boundaries can be set equal to 1  
and the Electromagnetic Force Strength is given by  
the SpaceTime  $T^4$  volume.

One fourth of the Electromagnetic Force Strength is give by  $2\pi$ .

The total Electromagnetic Force Strength  
relative to the geometric strength of Einstein-Hilbert Gravity is  $1/137.03608$

The force strength is given at the characteristic energy level  
of the generalized Bohr radius which for U(1) Electromagnetism is about 4KeV.

## Weak Boson

The Standard Model SU(2) Weak Force bosons live in a SU(2) subalgebra of the U(2) local group of CP2 = SU(3) / U(2). They "see" M4 Physical spacetime as two 2-spheres S2 x S2 each of whose dimension is 2 and each of whose volume is 4 pi

Their part of the Physical Lagrangian is

$$\int_{S^2 \times S^2} \text{SU(2) Weak Force Gauge Boson Term}$$

an integral over SpaceTime S2 x S2.

Schwinger Source for SU(2) Weak Force bosons is the Complex Bounded Domain is two copies of IV3 Lie Ball each with Symmetric Space Lie Sphere Spin(5) / Spin(3)xU(1) and volume pi^3 / 24 and Shilov Boundary RP1 x S2 with volume 4 pi^2

Due to the action of the Higgs mechanism, for the Weak Force, the effective force strength that we see in our experiments is suppressed by the Weak Boson masses squared ( 1 / ( MW+^2 + MW-^2 + MWO^2 ) ). The unsuppressed Weak Force strength is the Geometric Part of the force strength.

One half of the Geometric Weak Force Strength is given by ( 4 pi ) ( 4 pi^2 ) / ( pi^3 / 24 )^( 1 / 2 )

( pi^3 / 24 )^( 1 / 2 ) = ( Vol(IV3) )^( 1 / 2 ) is a dimensional normalization factor to reconcile the dimensionality of the Internal Symmetry Space Bounded Domain with the dimensionality of Spacetime Lagrangian Base Manifold.

The geometric force strength, relative to the geometric strength of Einstein-Hilbert Gravity, of the Weak Force is 0.2535

The total force strength of the SU(2) Weak Force, including the suppression factor of the Weak Boson masses squared, is given by  $G_w \times M_{\text{proton}}^2 = \text{about } 1.05 \times 10^{-5}$

Note that MWO is the mass of the SU(2) WO Weak boson that combines with the U(1) boson by the Higgs mechanism to form the Zo Weak boson and the Photon. MWO is about 98 GeV, MW+ = MW- is about 80 GeV, MZo is about 92 GeV, and the Photon is massless.



## Gluon

The Standard Model SU(3) Color Force bosons ( gluons ) live in a SU(3) subalgebra of the SU(4) subalgebra of  $D_4 = Spin(8)$ . They "see" M4 Physical spacetime as the complex projective plane CP2 whose dimension is 4 and whose volume is  $8 \pi^2 / 3$

Their part of the Physical Lagrangian is

$\int_{CP2}$  SU(3) Color Force Gauge Boson Term  
CP2  
an integral over SpaceTime CP2.

Schwinger Source for SU(3) Color Force bosons ( gluons ) is the Complex Bounded Domain B6 (ball) with Symmetric Space SU(4) / SU(3)xU(1) and volume  $\pi^3 / 6$  and Shilov Boundary S5 with volume  $4 \pi^3$

The Color Force Strength is given by  
( Vol(CP2)) ( Vol(S5) / Vol(B6)<sup>( 1 / 4 )</sup> )

Vol(B6)<sup>( 1 / 4 )</sup> is a dimensional normalization factor to reconcile the dimensionality of the Internal Symmetry Space Bounded Domain with the dimensionality of Spacetime Lagrangian Base Manifold.

The force strength, relative to the geometric strength of Einstein-Hilbert Gravity, of the SU(3) Color Force is 0.6286 at the characteristic energy level of the Color Force (about 245 MeV).

The color force strength was calculated using a simple perturbative QCD renormalization group equation at various energies, with the following results:  
Energy Level Color Force Strength

245 MeV	0.6286
5.3 GeV	0.166
34 GeV	0.121
91 GeV	0.106

Taking other effects, such as Nonperturbative QCD, into account, should give a Color Force Strength of about 0.125 at about 91 GeV

Note ( thanks to Carlos Castro for noticing these ) that the volume listed for S5 is for a squashed S5, a Shilov boundary of the complex domain corresponding to the symmetric space SU(4) / SU(3) x U(1) and also that the volume listed for CP2 is unconventional, but physically justified by noting that S4 and CP2 can be seen as having the same physical volume, with the only difference being structure at infinity.

## Conformal Graviton

The Gravity Gauge Bosons (Schwinger-Euclidean versions) live in a Spin(5) subalgebra of the Spin(6) Conformal subalgebra of  $D_4 = Spin(8)$ . They "see" M4 Physical spacetime as the 4-sphere  $S^4$  whose dimension is 4 and whose volume is  $8 \pi^2 / 3$

Their part of the Physical Lagrangian is

$$\int_{S^4} \text{Gravity Gauge Boson Term}$$

an integral over SpaceTime  $S^4$ .

Schwinger Source for Spin(5) MacDowell-Mansouri Gravity bosons is the Complex Bounded Domain IV5 Lie Ball with Symmetric Space Lie Sphere  $Spin(7) / Spin(5) \times U(1)$  and volume  $\pi^5 / 2^4 5!$  and Shilov Boundary  $RP^1 \times S^4$  with volume  $8 \pi^3 / 3$

Due to Stabilization of Condensate SpaceTime by virtual Planck Mass Gravitational Black Holes, the effective force strength of Gravity that we see in our experiments is suppressed by the square of the Planck Mass ( $1 / M_{\text{Planck}}^2$ ). The unsuppressed Gravity force strength is the Geometric Part of the force strength.

The Geometric Einstein-Hilbert Gravity Strength is given by  $(\text{Vol}(S^4)) (\text{Vol}(IV5) / \text{Vol}(RP^1 \times S^4))^{1/4}$

$\text{Vol}(RP^1 \times S^4)^{1/4}$  is a dimensional normalization factor to reconcile the dimensionality of the Internal Symmetry Space Bounded Domain with the dimensionality of Spacetime Lagrangian Base Manifold.

The geometric force strength, relative to the geometric strength of Einstein-Hilbert Gravity, of Spin(5) MacDowell-Mansouri Gravity is obviously 1.

The total force strength  $G_{\text{grav}}$  of Spin(5) MacDowell-Mansouri Gravity, including the Planck Mass squared suppression factor, is given by  $G_{\text{grav}} \times M_{\text{proton}}^2 = \text{about } 5 \times 10^{-39}$

## Higgs, W+, W-, Z0:

As with forces strengths, the calculations produce ratios of masses, so that only one mass need be chosen to set the mass scale.

In the Cl(1,25) E8 model, the value of the fundamental mass scale vacuum expectation value  $v = \langle \text{PHI} \rangle$  of the Higgs scalar field is set to be the sum of the physical masses of the weak bosons, W+, W-, and Z0, whose tree-level masses will then be shown by ratio calculations to be 80.326 GeV, 80.326 GeV, and 91.862 GeV, respectively, and therefore the electron mass will be 0.5110 MeV.

The relationship between the Higgs mass and  $v$  is given by the Ginzburg-Landau term from the Mayer Mechanism as

$$(1/4) \text{Tr} ( [ \text{PHI} , \text{PHI} ] - \text{PHI} )^2$$

or, i

n the notation of quant-ph/9806009 by Guang-jiong Ni

$$(1/4!) \lambda \text{PHI}^4 - (1/2) \sigma \text{PHI}^2$$

where the Higgs mass  $M_H = \sqrt{2 \sigma}$

Ni says:

"... the invariant meaning of the constant  $\lambda$  in the Lagrangian is not the coupling constant, the latter will change after quantization ... The invariant meaning of  $\lambda$  is nothing but the ratio of two mass scales:

$$\lambda = 3 ( M_H / \text{PHI} )^2$$

which remains unchanged irrespective of the order ...".

Since  $\langle \text{PHI} \rangle^2 = v^2$ , and assuming that  $\lambda = ( \cos( \pi / 6 ) )^2 = 0.866^2$  ( a value consistent with the Higgs-Tquark condensate model of Michio Hashimoto, Masaharu Tanabashi, and Koichi Yamawaki in their paper at hep-ph/0311165 ) we have

$$M_H^2 / v^2 = ( \cos( \pi / 6 ) )^2 / 3$$

In the Cl(1,25) E8 model, the fundamental mass scale vacuum expectation value  $v$  of the Higgs scalar field is the fundamental mass parameter that is to be set to define all other masses by the mass ratio formulas of the model and  $v$  is set to be 252.514 GeV so that

$$M_H = v \cos( \pi / 6 ) / \sqrt{1 / 3} = 126.257 \text{ GeV}$$

This is the value of the Low Mass State of the Higgs observed by the LHC. Middle and High Mass States come from a Higgs-Tquark Condensate System. The Middle and High Mass States may have been observed by the LHC at 20% of the Low Mass State cross section, and that may be confirmed by the LHC 2015-1016 run.

A Non-Condensate Higgs is represented by a Higgs at a point in M4 that is connected to a Higgs representation in CP2 ISS by a line whose length represents the Higgs mass

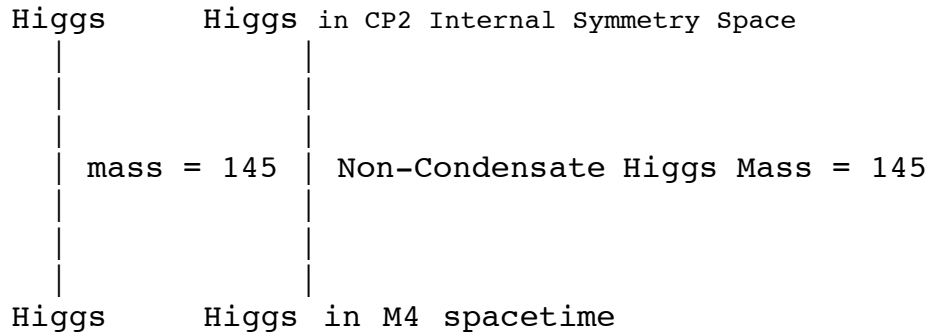

and the value of lambda is  $1 = 1^2$   
 so that the Higgs mass would be  $M_H = v / \sqrt{3} = 145.789 \text{ GeV}$

However, in the  $Cl(1,25)$  E8 model, the Higgs has structure of a Tquark condensate

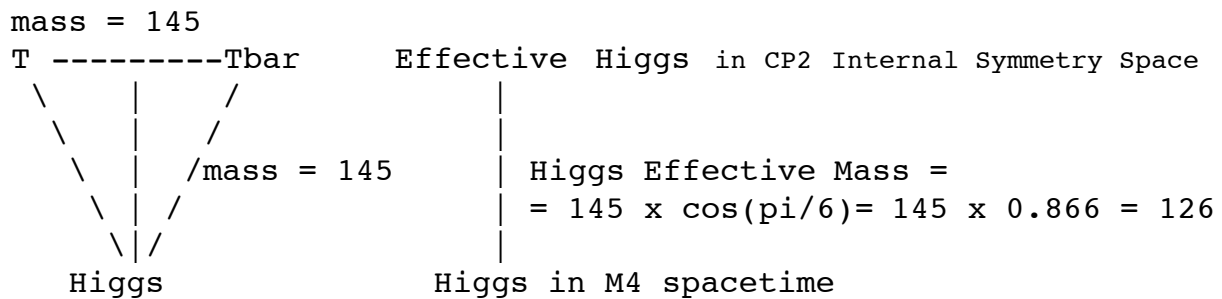

in which the Higgs at a point in M4 is connected to a T and Tbar in CP2 ISS so that the vertices of the Higgs-T-Tbar system are connected by lines forming an equilateral triangle composed of 2 right triangles (one from the CP2 origin to the T and to the M4 Higgs and another from the CP2 origin to the Tbar and to the M4 Higgs).

In the T-quark condensate picture  
 $\lambda = 1^2 = \lambda(T) + \lambda(H) = (\sin(\pi / 6))^2 + (\cos(\pi / 6))^2$   
 and  
 $\lambda(H) = (\cos(\pi / 6))^2$

Therefore the Effective Higgs mass observed by LHC is:

$$\text{Higgs Mass} = 145.789 \times \cos(\pi/6) = 126.257 \text{ GeV.}$$

To get W-boson masses,  
denote the 3 SU(2) high-energy weak bosons  
(massless at energies higher than the electroweak unification)  
by  $W_+$ ,  $W_-$ , and  $W_0$ ,  
corresponding to the massive physical weak bosons  $W_+$ ,  $W_-$ , and  $Z_0$ .

The triplet  $\{ W_+, W_-, W_0 \}$  couples directly with the T - Tbar quark-antiquark pair,  
so that the total mass of the triplet  $\{ W_+, W_-, W_0 \}$  at the electroweak unification  
is equal to the total mass of a T - Tbar pair, 259.031 GeV.

The triplet  $\{ W_+, W_-, Z_0 \}$  couples directly with the Higgs scalar,  
which carries the Higgs mechanism by which the  $W_0$  becomes the physical  $Z_0$ ,  
so that the total mass of the triplet  $\{ W_+, W_-, Z_0 \}$   
is equal to the vacuum expectation value  $v$  of the Higgs scalar field,  $v = 252.514$  GeV.

What are individual masses of members of the triplet  $\{ W_+, W_-, Z_0 \}$  ?

First, look at the triplet  $\{ W_+, W_-, W_0 \}$  which can be represented by the 3-sphere  $S^3$ .  
The Hopf fibration of  $S^3$  as

$$S^1 \rightarrow S^3 \rightarrow S^2$$

gives a decomposition of the W bosons into the neutral  $W_0$  corresponding to  $S^1$   
and the charged pair  $W_+$  and  $W_-$  corresponding to  $S^2$ .

The mass ratio of the sum of the masses of  $W_+$  and  $W_-$  to the mass of  $W_0$   
should be the volume ratio of the  $S^2$  in  $S^3$  to the  $S^1$  in  $S^3$ .

The unit sphere  $S^3$  in  $R^4$  is normalized by  $1/2$ .

The unit sphere  $S^2$  in  $R^3$  is normalized by  $1/\sqrt{3}$ .

The unit sphere  $S^1$  in  $R^2$  is normalized by  $1/\sqrt{2}$ .

The ratio of the sum of the  $W_+$  and  $W_-$  masses to the  $W_0$  mass should then be  
 $(2/\sqrt{3}) V(S^2) / (2/\sqrt{2}) V(S^1) = 1.632993$

Since the total mass of the triplet  $\{ W_+, W_-, W_0 \}$  is 259.031 GeV,  
the total mass of a T - Tbar pair, and the charged weak bosons have equal mass,  
we have

$$M_{W_+} = M_{W_-} = 80.326 \text{ GeV and } M_{W_0} = 98.379 \text{ GeV.}$$

The charged  $W_{\pm}$  neutrino-electron interchange must be symmetric  
with the electron-neutrino interchange, so that the tree-level absence  
of right-handed neutrino particles requires that

the charged  $W_{\pm}$  SU(2) weak bosons act only on left-handed electrons.

Each gauge boson must act consistently on the entire Dirac fermion particle sector,  
so that the  
charged  $W_{\pm}$  SU(2) weak bosons act only on left-handed fermion particles of all types.

The neutral  $W_0$  weak boson does not interchange Weyl neutrinos with Dirac fermions, and so is not restricted to left-handed fermions, but also has a component that acts on both types of fermions, both left-handed and right-handed, conserving parity.

However, the neutral  $W_0$  weak bosons are related to the charged  $W_{+/-}$  weak bosons by custodial  $SU(2)$  symmetry, so that the left-handed component of the neutral  $W_0$  must be equal to the left-handed (entire) component of the charged  $W_{+/-}$ .

Since the mass of the  $W_0$  is greater than the mass of the  $W_{+/-}$ , there remains for the  $W_0$  a component acting on both types of fermions.

Therefore the full  $W_0$  neutral weak boson interaction is proportional to  $(M_{W_{+/-}}^2 / M_{W_0}^2)$  acting on left-handed fermions and  $(1 - (M_{W_{+/-}}^2 / M_{W_0}^2))$  acting on both types of fermions.

If  $(1 - (M_{W_{+/-}}^2 / M_{W_0}^2))$  is defined to be  $\sin(\theta_w)^2$  and denoted by  $K$ , and if the strength of the  $W_{+/-}$  charged weak force (and of the custodial  $SU(2)$  symmetry) is denoted by  $T$ , then the  $W_0$  neutral weak interaction can be written as  $W_0L = T + K$  and  $W_0LR = K$ .

Since the  $W_0$  acts as  $W_0L$  with respect to the parity violating  $SU(2)$  weak force and as  $W_0LR$  with respect to the parity conserving  $U(1)$  electromagnetic force, the  $W_0$  mass  $m_{W_0}$  has two components: the parity violating  $SU(2)$  part  $m_{W_0L}$  that is equal to  $M_{W_{+/-}}$  and the parity conserving part  $M_{W_0LR}$  that acts like a heavy photon.

As  $M_{W_0} = 98.379 \text{ GeV} = M_{W_0L} + M_{W_0LR}$ , and as  $M_{W_0L} = M_{W_{+/-}} = 80.326 \text{ GeV}$ , we have  $M_{W_0LR} = 18.053 \text{ GeV}$ .

Denote by  $\alpha_E = e^2$  the force strength of the weak parity conserving  $U(1)$  electromagnetic type force that acts through the  $U(1)$  subgroup of  $SU(2)$ .

The electromagnetic force strength  $\alpha_E = e^2 = 1 / 137.03608$  was calculated above using the volume  $V(S^1)$  of an  $S^1$  in  $R^2$ , normalized by  $1 / \sqrt{2}$ .

The  $\alpha_E$  force is part of the  $SU(2)$  weak force whose strength  $\alpha_W = w^2$  was calculated above using the volume  $V(S^2)$  of an  $S^2 \subset R^3$ , normalized by  $1 / \sqrt{3}$ .

Also, the electromagnetic force strength  $\alpha_E = e^2$  was calculated above using a 4-dimensional spacetime with global structure of the 4-torus  $T^4$  made up of four  $S^1$  1-spheres, while the  $SU(2)$  weak force strength  $\alpha_W = w^2$  was calculated above using two 2-spheres  $S^2 \times S^2$ , each of which contains one 1-sphere of the  $\alpha_E$  force.

Therefore

$$\begin{aligned} *alphaE &= alphaE ( \sqrt{ 2 } / \sqrt{ 3 } )(2 / 4) = alphaE / \sqrt{ 6 } , \\ *e &= e / (4th \text{ root of } 6) = e / 1.565 , \end{aligned}$$

and

the mass mW0LR must be reduced to an effective value

$$M\_W0LReff = M\_W0LR / 1.565 = 18.053/1.565 = 11.536 \text{ GeV}$$

for the \*alphaE force to act like an electromagnetic force in the E8 model:

$$*e M\_W0LR = e (1/5.65) M\_W0LR = e M\_Z0,$$

where the physical effective neutral weak boson is denoted by Z0.

Therefore, the correct Cl(1,25) E8 model values for weak boson masses and the Weinberg angle theta\_w are:

$$M\_W+ = M\_W- = 80.326 \text{ GeV};$$

$$M\_Z0 = 80.326 + 11.536 = 91.862 \text{ GeV};$$

$$\text{Sin}(\text{theta}_w)^2 = 1 - (M\_W+/- / M\_Z0)^2 = 1 - ( 6452.2663 / 8438.6270 ) = 0.235.$$

Radiative corrections are not taken into account here, and may change these tree-level values somewhat.

## Proton-Neutron Mass Difference

An up valence quark, constituent mass 313 Mev,  
does not often swap places with a 2.09 Gev charm sea quark,  
but  
a 313 Mev down valence quark  
can more often swap places with a 625 Mev strange sea quark.

Therefore the Quantum color force  
constituent mass of the down valence quark is heavier by about

$$(m_s - m_d) (m_d/m_s)^2 a(w) |V_{ds}| = 312 \times 0.25 \times 0.253 \times 0.22 \text{ Mev} = 4.3 \text{ Mev},$$

(where  $a(w) = 0.253$  is the geometric part of the weak force strength  
and  $|V_{ds}| = 0.22$  is the magnitude  
of the K-M parameter mixing first generation down and second generation strange)

so that the Quantum color force constituent mass  $Q_{md}$  of the down quark is

$$Q_{md} = 312.75 + 4.3 = 317.05 \text{ MeV}.$$

Similarly, the up quark Quantum color force mass increase is about

$$(m_c - m_u) (m_u/m_c)^2 a(w) |V_{uc}| = 1777 \times 0.022 \times 0.253 \times 0.22 \text{ Mev} = 2.2 \text{ Mev},$$

(where  $|V_{uc}| = 0.22$  is the magnitude  
of the K-M parameter mixing first generation up and second generation charm)

so that the Quantum color force constituent mass  $Q_{mu}$  of the up quark is

$$Q_{mu} = 312.75 + 2.2 = 314.95 \text{ MeV}.$$

Therefore, the Quantum color force Neutron-Proton mass difference is

$$m_N - m_P = Q_{md} - Q_{mu} = 317.05 \text{ Mev} - 314.95 \text{ Mev} = 2.1 \text{ Mev}.$$

Since the electromagnetic Neutron-Proton mass difference is roughly

$$m_N - m_P = -1 \text{ MeV}$$

the total theoretical Neutron-Proton mass difference is

$$m_N - m_P = 2.1 \text{ Mev} - 1 \text{ Mev} = 1.1 \text{ Mev},$$

an estimate that is comparable to the experimental value of 1.3 Mev.



## Pion as Sine-Gordon Breather

The quark content of a charged pion is a quark - antiquark pair: either Up plus antiDown or Down plus antiUp. Experimentally, its mass is about 139.57 MeV.

The quark is a Schwinger Source Kerr-Newman Black Hole with constituent mass  $M$  312 MeV.

The antiquark is also a Schwinger Source Kerr-Newman Black Hole, with constituent mass  $M$  312 MeV.

According to section 3.6 of Jeffrey Winicour's 2001 Living Review of the Development of Numerical Evolution Codes for General Relativity (see also a 2005 update):

"... The black hole event horizon associated with ... slightly broken ... degeneracy [ of the axisymmetric configuration ]... reveals new features not seen in the degenerate case of the head-on collision ... If the degeneracy is slightly broken, the individual black holes form with spherical topology but as they approach, tidal distortion produces two sharp pincers on each black hole just prior to merger. ...

Tidal distortion of approaching black holes ... Formation of sharp pincers just prior to merger ..

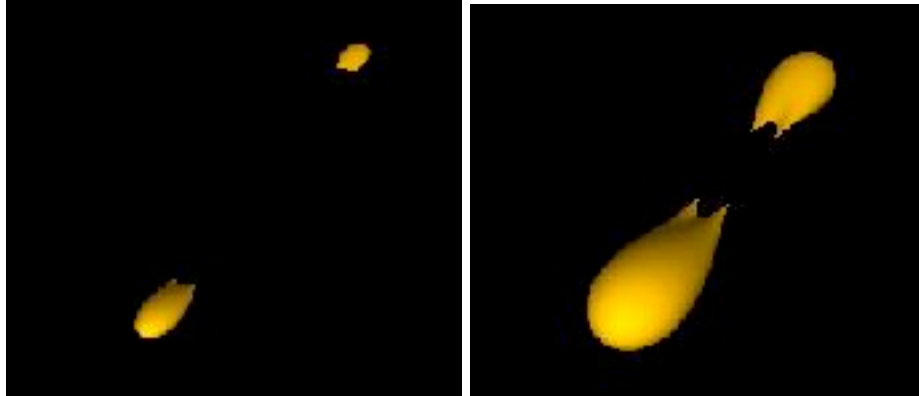

... toroidal stage just after merger ...

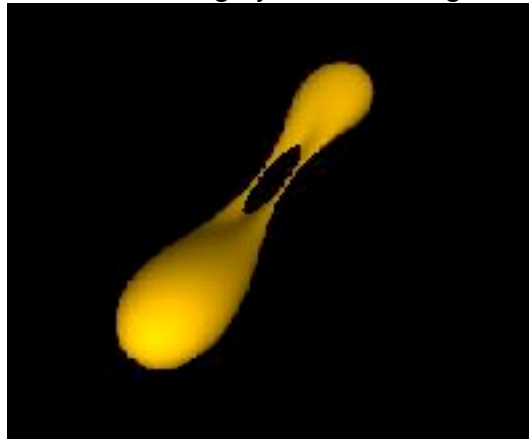

At merger, the two pincers join to form a single ... toroidal black hole.

The inner hole of the torus subsequently [ begins to] close... up (superluminally) ... [ If the closing proceeds to completion, it ]... produce[s] first a peanut shaped black hole and finally a spherical black hole. ...".

In the physical case of quark and antiquark forming a pion, the toroidal black hole remains a torus.

The torus is an event horizon and therefore is not a 2-spacelike dimensional torus, but is a (1+1)-dimensional torus with a timelike dimension.

The effect is described in detail in Robert Wald's book General Relativity (Chicago 1984). It can be said to be due to extreme frame dragging, or to timelike translations becoming spacelike as though they had been Wick rotated in Complex SpaceTime.

As Hawking and Ellis say in The LargeScale Structure of Space-Time (Cambridge 1973):

"... The surface  $r = r_+$  is ... the event horizon ... and is a null surface ...

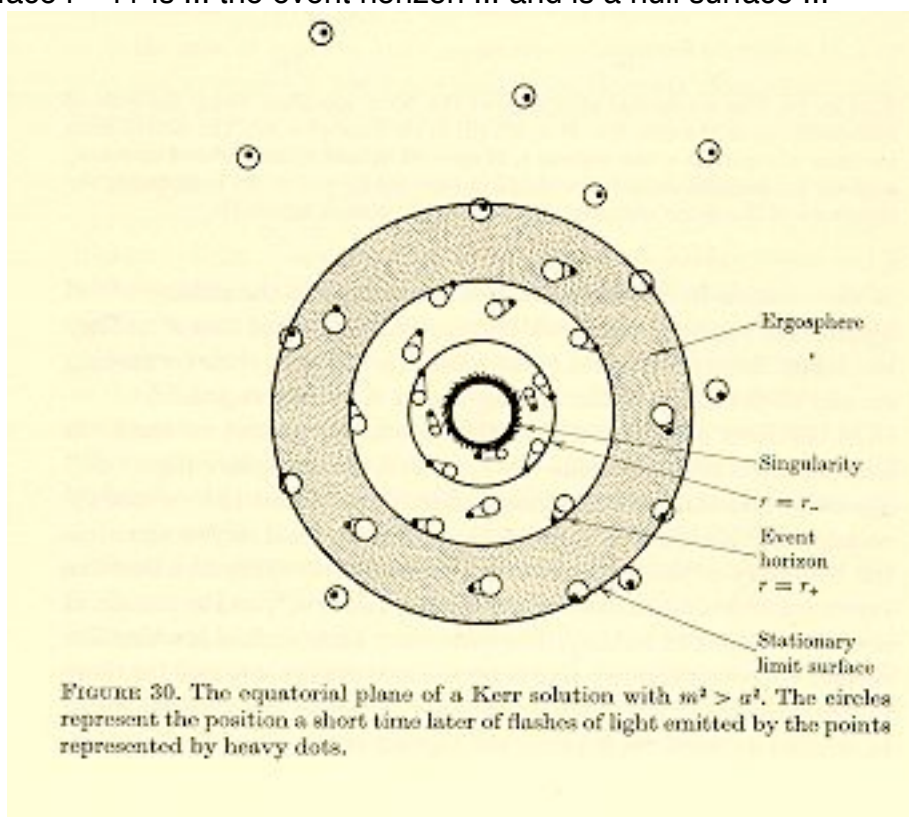

FIGURE 30. The equatorial plane of a Kerr solution with  $m^2 > a^2$ . The circles represent the position a short time later of flashes of light emitted by the points represented by heavy dots.

... On the surface  $r = r_+$  .... the wavefront corresponding to a point on this surface lies entirely within the surface. ...".

A (1+1)-dimensional torus with a timelike dimension can carry a Sine-Gordon Breather. The soliton and antisoliton of a Sine-Gordon Breather correspond to the quark and antiquark that make up the pion, analogous to the Massive Thirring Model.

Sine-Gordon Breathers are described by Sidney Coleman in his Erica lecture paper Classical Lumps and their Quantum Descendants (1975), reprinted in his book Aspects of Symmetry (Cambridge 1985), where he writes the Lagrangian for the Sine-Gordon equation as ( Coleman's eq. 4.3 ):

$$L = (1 / B^2) ( (1/2) (df)^2 + A ( \cos( f ) - 1 ) )$$

Coleman says: "... We see that, in classical physics, B is an irrelevant parameter: if we can solve the sine-Gordon equation for any non-zero B, we can solve it for any other B.

The only effect of changing B is the trivial one of changing the energy and momentum assigned to a given solution of the equation. This is not true in quantum physics, because the relevant object for quantum physics is not L but [ eq. 4.4 ]

$$L / \hbar = (1 / ( B^2 \hbar ) ) ( (1/2) (df)^2 + A ( \cos( f ) - 1 ) )$$

An other way of saying the same thing is to say that in quantum physics we have one more dimensional constant of nature, Planck's constant, than in classical physics. ... the classical limit, vanishing  $\hbar$ , is exactly the same as the small-coupling limit, vanishing B ... from now on I will ... set  $\hbar$  equal to one. ...

... the sine-Gordon equation ... [ has ] ... an exact periodic solution ... [ eq. 4.59 ] ...

$$f( x, t ) = ( 4 / B ) \arctan( ( n \sin( w t ) / \cosh( n w x ) )$$

where [ eq. 4.60 ]  $n = \sqrt{ A - w^2 } / w$  and  $w$  ranges from 0 to A.

This solution has a simple physical interpretation ... a soliton far to the left ... [ and ] ... an antisoliton far to the right. As  $\sin( w t )$  increases, the soliton and antisoliton move farther apart from each other. When  $\sin( w t )$  passes through one, they turn around and begin to approach one another. As  $\sin( w t )$  comes down to zero ... the soliton and antisoliton are on top of each other ... when  $\sin( w t )$  becomes negative .. the soliton and antisoliton have passed each other.

... Thus, Eq. (4.59) can be thought of as a soliton and an antisoliton oscillation about their common center-of-mass. For this reason, it is called 'the doublet [ or Breather ] solution'. ... the energy of the doublet ... [ eq. 4.64 ]

$$E = 2 M \sqrt{ 1 - ( w^2 / A ) }$$

where [ eq. 4.65 ]  $M = 8 \sqrt{ A } / B^2$  is the soliton mass.

Note that the mass of the doublet is always less than twice the soliton mass, as we would expect from a soliton-antisoliton pair. ...

Dashen, Hasslacher, and Neveu ... Phys. Rev. D10, 4114; 4130; 4138 (1974).  
 ...[ found that ]... there is only a single series of bound states, labeled by the integer N ...  
 The energies ... are ... [ eq. 4.82 ]

$$E_N = 2 M \sin( B'^2 N / 16 )$$

where  $N = 0, 1, 2 \dots < 8 \pi / B'^2$ , [ eq. 4.83 ]

$B'^2 = B^2 / ( 1 - ( B^2 / 8 \pi ) )$  and M is the soliton mass.

M is not given by Eq. ( 4.65 ), but is the soliton mass corrected by the DHN formula, or, equivalently, by the first-order weak coupling expansion. ...

I have written the equation in this form .. to eliminate A, and thus avoid worries about renormalization conventions.

Note that the DHN formula is identical to the Bohr-Sommerfeld formula, except that B is replaced by B'.

Bohr and Sommerfeld[s] ... quantization formula says that if we have a one-parameter family of periodic motions, labeled by the period, T, then an energy eigenstate occurs whenever [ eq. 4.66 ]

$$[ \text{Integral from 0 to T} ]( dt p \dot{q} = 2 \pi N,$$

where N is an integer. ... Eq.( 4.66 ) is cruder than the WKB formula, but it is much more general;

it is always the leading approximation for any dynamical system ...

Dashen et al speculate that Eq. ( 4.82 ) is exact. ...

the sine-Gordon equation is equivalent ... to the massive Thirring model.

This is surprising,

because the massive Thirring model is a canonical field theory

whose Hamiltonian is expressed in terms of fundamental Fermi fields only.

Even more surprising, when  $B^2 = 4 \pi$ , that sine-Gordon equation is equivalent to a free massive Dirac theory, in one spatial dimension. ...

Furthermore, we can identify the mass term in the Thirring model with the sine-Gordon interaction, [ eq. 5.13 ]

$$M = - ( A / B^2 ) N_m \cos( B f )$$

.. to do this consistently ... we must say [ eq. 5.14 ]

$$B^2 / ( 4 \pi ) = 1 / ( 1 + g / \pi )$$

....[where]... g is a free parameter, the coupling constant [ for the Thirring model ]...

Note that if  $B^2 = 4 \pi$ ,  $g = 0$ ,

and the sine-Gordon equation is the theory of a free massive Dirac field. ...

It is a bit surprising to see a fermion appearing as a coherent state of a Bose field.

Certainly this could not happen in three dimensions,

where it would be forbidden by the spin-statistics theorem.

However, there is no spin-statistics theorem in one dimension,

for the excellent reason that there is no spin. ...

the lowest fermion-antifermion bound state of the massive Thirring model

is an obvious candidate for the fundamental meson of sine-Gordon theory. ...

equation ( 4.82 ) predicts that

all the doublet bound states disappear when  $B^2$  exceeds  $4 \pi$ .

This is precisely the point where the Thirring model interaction switches from attractive to repulsive. ... these two theories ... the massive Thirring model .. and ... the sine-Gordon equation ... define identical physics. ...

I have computed the predictions of ...[various]... approximation methods for the ration of the soliton mass to the meson mass for three values of  $B^2$  :  $4\pi$  (where the qualitative picture of the soliton as a lump totally breaks down),  $2\pi$ , and  $\pi$  . At  $4\pi$  we know the exact answer ... I happen to know the exact answer for  $2\pi$ , so I have included this in the table. ...

Method	$B^2 = \pi$	$B^2 = 2\pi$	$B^2 = 4\pi$
Zeroth-order weak coupling expansion eq2.13b	2.55	1.27	0.64
Coherent-state variation	2.55	1.27	0.64
First-order weak coupling expansion	2.23	0.95	0.32
Bohr-Sommerfeld eq4.64	2.56	1.31	0.71
DHN formula eq4.82	2.25	1.00	0.50
Exact	?	1.00	0.50

...[eq. 2.13b ]

$$E = 8 \sqrt{A} / B^2$$

...[ is the ]... energy of the lump ... of sine-Gordon theory ... frequently called 'soliton...' in the literature ...

[ Zeroth-order is the classical case, or classical limit. ] ...

... Coherent-state variation always gives the same result as the ... Zeroth-order weak coupling expansion ... . The ... First-order weak-coupling expansion ... explicit formula ... is  $( 8 / B^2 ) - ( 1 / \pi )$ . ...".

Using the  $Cl(1,25)$  E8 model constituent mass of the Up and Down quarks and antiquarks, about 312.75 MeV, as the soliton and antisoliton masses, and setting  $B^2 = \pi$  and using the DHN formula, the mass of the charged pion is calculated to be  $( 312.75 / 2.25 )$  MeV = 139 MeV which is close to the experimental value of about 139.57 MeV.

**Why is the value  $B^2 = \pi$  the special value that gives the pion mass ?**

( or, using Coleman's eq. ( 5.14 ), the Thirring coupling constant  $g = 3\pi$  )

**Because  $B^2 = \pi$  is where the First-order weak coupling expansion substantially coincides with the ( probably exact ) DHN formula.** In other words,

**The physical quark - antiquark pion lives where the first-order weak coupling expansion is exact.**

## Planck Mass as Superposition Fermion Condensate

At a single spacetime vertex, a Planck-mass black hole is the Many-Worlds quantum sum of all possible virtual first-generation particle-antiparticle fermion pairs allowed by the Pauli exclusion principle to live on that vertex.

Once a Planck-mass black hole is formed, it is stable in the E8 model. Less mass would not be gravitationally bound at the vertex. More mass at the vertex would decay by Hawking radiation.

There are 8 fermion particles and 8 fermion antiparticles for a total of 64 particle-antiparticle pairs. Of the 64 particle-antiparticle pairs, 12 are bosonic pions.

A typical combination should have about 6 pions so it should have a mass of about  $.14 \times 6 \text{ GeV} = 0.84 \text{ GeV}$ .

Just as the pion mass of  $.14 \text{ GeV}$  is less than the sum of the masses of a quark and an antiquark, pairs of oppositely charged pions may form a bound state of less mass than the sum of two pion masses.

If such a bound state of oppositely charged pions has a mass as small as  $.1 \text{ GeV}$ , and if the typical combination has one such pair and 4 other pions, then the typical combination could have a mass in the range of  $0.66 \text{ GeV}$ .

Summing over all  $2^{64}$  combinations, the total mass of a one-vertex universe should give a Planck mass roughly around  $0.66 \times 2^{64} = 1.217 \times 10^{19} \text{ GeV}$ .

The value for the Planck mass given in by the 1998 Particle Data Group is  $1.221 \times 10^{19} \text{ GeV}$ .

## **Quantum Bohmion**

Quantum Bohmion = symmetric traceless spin-2 of 26D World-Line=String Theory

## Quantum Kernel Functions and Schwinger Source Green's Functions

Fock "Fundamental of Quantum Mechanics" (1931) showed that it requires Linear Operators "... represented by a definite integral [of a]... kernel ... function ...".

Hua "Harmonic Analysis of Functions of Several Complex Variables in the Classical Domains" (1958) showed Kernel Functions for Complex Classical Domains.

Schwinger (1951 - see Schweber, PNAS 102, 7783-7788) "... introduced a description in terms of Green's functions, what Feynman had called propagators ... The Green's functions are vacuum expectation values of time-ordered Heisenberg operators, and the field theory can be defined non-perturbatively in terms of these functions ...[which]... gave deep structural insights into QFTs; in particular ... the structure of the Green's functions when their variables are analytically continued to complex values ...".

Wolf (J. Math. Mech 14 (1965) 1033-1047) showed that the Classical Domains (complete simply connected Riemannian symmetric spaces) representing 4-dim Spacetime with Quaternionic Structure are:

$$\begin{aligned} S^1 \times S^1 \times S^1 \times S^1 &= 4 \text{ copies of } U(1) \\ S^2 \times S^2 &= 2 \text{ copies of } SU(2) \\ CP^2 &= SU(3) / SU(2) \times U(1) \\ S^4 &= Spin(5) / Spin(4) = \text{Euclidean version of } Spin(2,3) / Spin(1,3) \end{aligned}$$

**Armand Wyler** (1971 - C. R. Acad. Sc. Paris, t. 271, 186-188) showed how to use **Green's Functions = Kernel Functions** of Classical Domain structures characterizing **Sources = Leptons, Quarks, and Gauge Bosons,** to calculate **Particle Masses and Force Strengths**

Schwinger (1969 - see physics/0610054) said: "... operator field theory ... replace[s] the particle with ... properties ... distributed throughout ... small volumes of three-dimensional space ... particles ... must be created ... even though we vary a number of experimental parameters ... The properties of the particle ... remain the same ... We introduce a quantitative description of the particle source in terms of a source function ... we do not have to claim that we can make the source arbitrarily small ... the experimenter... must detect the particles ...[by]... collision that annihilates the particle ... the source ... can be ... an abstraction of an annihilation collision, with the source acting negatively, as a sink ... The basic things are ... the source functions ... describing the intermediate propagation of the particle ...".

**Creation and Annihilation operators** indicate a Clifford Algebra, and 8-Periodicity shows that the basic Clifford Algebra is formed by tensor products of 256-dim  $Cl(8)$  such as  $Cl(8) \times Cl(8) = Cl(16)$  containing 248-dim  $E_8 = 120\text{-dim } D_8 + 128\text{-dim } D_8$  half-spinor whose maximal contraction is a realistic generalized Heisenberg Algebra

$$h_{92} \times A_7 = 5\text{-graded } 28 + 64 + ((SL(8, R) + 1) + 64 + 28$$



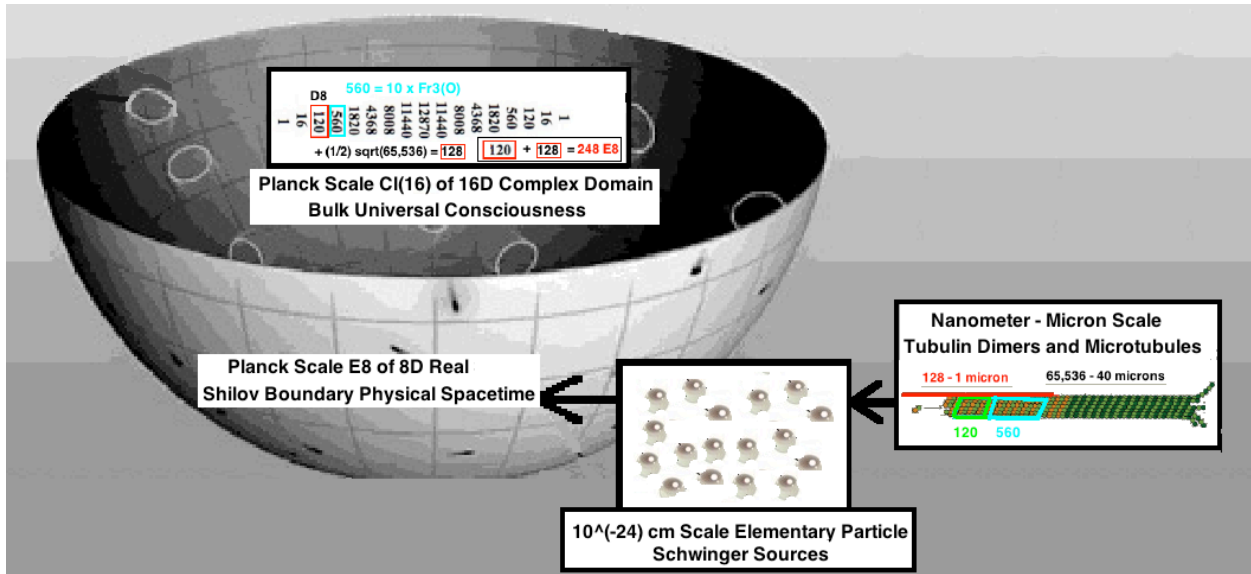

In E8-Cl(16) Physics **Spacetime is the 8-dimensional Shilov Boundary RP1 x S7** of the **Type IV8 Bounded Complex Domain Bulk Space** of the Symmetric Space Spin(10) / Spin(8)xU(1) which **Bulk Space** has 16 Real dimensions and is the Vector Space of the Real Clifford Algebra Cl(16).

By 8-Periodicity,

Cl(16) = tensor product Cl(8) x Cl(8) = Real 256x256 Matrix Algebra M(R,256) and so has 256x256 = 65,536 elements.

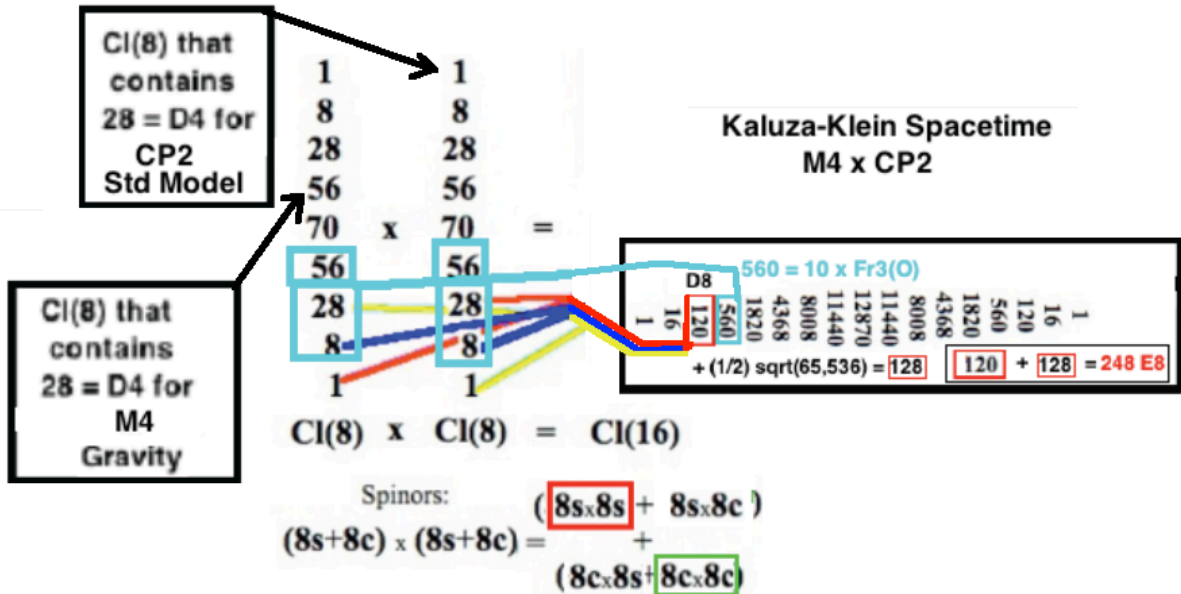

Cl(8) has 8 Vectors, 28 BiVectors, and 16 Spinors with 8+28+16 = 52 = F4 Lie Algebra and has 56 TriVectors for the Fr3(O) Freudenthal Algebra of World-Line String Theory.

Cl(16) has 120 BiVectors, and 128 Half-Spinors with 120+128 = 248 = E8 Lie Algebra, and has 560 TriVectors for 10 copies of Fr3(O).

The 248 E8 elements of Cl(16) define a Lagrangian for the Standard Model and for Gravity - Dark Energy so that  $65,536 - 248 - 560 = 64,728$  elements of Cl(16) can carry Bits of Information.

The Complex Bulk Space Cl(16) contains the Maximal Contraction of E8 which is  $H_{92} + A_7$  a generalized Heisenberg Algebra of Quantum Creation-Annihilation Operators with graded structure

$$28 + 64 + ((SL(8,R)+1) + 64 + 28$$

We live in the Physical Minkowski M4 part of Kaluza-Klein M4 x CP2 structure of  $RP^1 \times S^7$  **Boundary**.

(where  $CP^2 = SU(3) / SU(2) \times U(1)$  is Internal Symmetry Space of Standard Model gauge groups)

Our Consciousness is based on Binary States of Tubulin Dimers (each 4x4x8 nm size) in Microtubules.

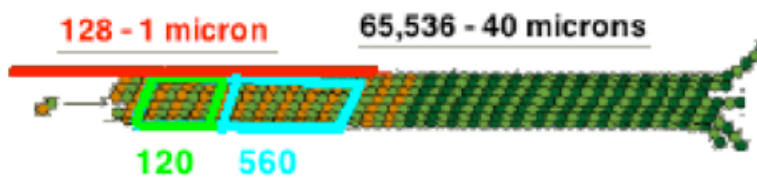

Microtubules are cylinders of sets of 13 Dimers with maximal length about 40,000 nm so that each Microtubule can contain about  $13 \times 40,000 / 8 = 65,000$  Bits of Information. The Physical Boundary in which we live is a Real Shilov Boundary in which E8 is manifested as Lagrangian Structure of Real Forms of E8 with Lagrangian Symmetric Space structure:

$E_8 / D_8 = (O \times O)P_2$  for 8 First-Generation Fermion Particles and 8 First-Generation Fermion AntiParticles (8 components of each)  
 $D_8 / D_4 \times D_4$  for 8-dim spacetime paths, one for each of 8 Fermion Types  
 $D_4$  for Standard Model Gauge Bosons and Gravity - Dark Energy Ghosts  
 $D_4$  for Gravity - Dark Energy Gauge Bosons, Propagator Phase, and Standard Model Ghosts

Microtubule Information in the Physical Shilov Boundary has Resonant Connection to Cl(16) Information in Bulk Complex Domain Spacetime by the spin-2 Bohm Quantum Potential with Sarfatti Back-Reaction of 26D String Theory of World-Lines consistent with Poisson Kernel as derivative of Green's function.

The Bulk Space Complex Domain Type IV8 corresponds to the Symmetric Space  $Spin(10) / Spin(8) \times U(1)$  and is a Lie Ball whose Shilov Boundary  $RP^1 \times S^7$  is a Lie Sphere 8-dim Spacetime. It is related to the Stiefel Manifold  $V(10,2) = Spin(10) / Spin(8)$  of dimension  $20-3 = 17$  by the fibration

$$Spin(10) / Spin(8) \times U(1) \rightarrow V(10,2) \rightarrow U(1)$$

It can also be seen as a tube  $z = x + iy$  whose imaginary part is physically inverse momentum so that its points give both position and momentum (see R. **Coquereaux** Nuc. Phys. B. 18B (1990) 48-52 "Lie Balls and Relativistic Quantum Fields").

In "Harmonic Analysis of Functions of Several Complex Variables in the Classical Domains" L. K. **Hua** said: "... Editor's Foreword ... M. I. Graev ...

Poisson kernel can be defined in group-theoretic terms. Let  $\mathfrak{R}$  be one of the domains considered in the book, and  $\mathfrak{C}$  its characteristic manifold. Let  $z$  be a point in  $\mathfrak{R}$  and  $C_z$  the group of those analytic automorphisms of  $\mathfrak{R}$  which leave  $z$  invariant. It can be shown that the group  $C_z$  is transitive on  $\mathfrak{C}$ , i.e., transforms any point of  $\mathfrak{C}$  into any other point. The measure on  $\mathfrak{C}$  which is invariant under the transformations in  $C_z$  is then simply equal to the Poisson kernel.

...[ Characteristic Manifold = Shilov Boundary ]...

In 1935, E. Cartan [1] proved that there exist only six types of irreducible homogeneous bounded symmetric domains. Beside the four types, RI, RII, RIII, RIV there exist only two; their dimensions are 16 and 27.  
 [ 16-Complex-Dimensional  $E_6 / Spin(10) \times U(1) = (C \times O)P_2$   
 27-Complex-Dimensional  $E_7 / E_6 \times U(1) = J(3, (C \times O))$  ]

The domain  $\mathfrak{R}_{IV}$  of  $n$ -dimensional ( $n > 2$ ) vectors

$$z = (z_1, z_2, \dots, z_n)$$

( $z_k$  are complex numbers) satisfying the conditions:

$$|zz'|^2 + 1 - 2zz' > 0, \quad |zz'| < 1.$$

The complex dimension of the four domains is  $mn, n(n+1)/2, n(n-1)/2, n$ .

The author has shown (cf. L. K. Hua [3]) that  $\mathfrak{R}_{IV}$  can also be regarded as a homogeneous space of  $2 \times n$  real matrices. Therefore, the study of all these domains can be reduced to a study of the geometry of matrices.

The manifolds  $\mathfrak{C}_I, \mathfrak{C}_{II}, \mathfrak{C}_{III}$  and  $\mathfrak{C}_{IV}$  have real dimension  $m(2n-m), n(n+1)/2, n(n-1)/2 + (1+(-1)^n)(n-1)/2$  and  $n$ , respectively.

The characteristic manifold of the domain  $\mathfrak{R}_{IV}$  consists of vectors of the form  $e^{i\theta}x$ , where  $0 \leq \theta \leq \pi$ , and  $x = (x_1, \dots, x_n)$  is a real vector which satisfies the condition  $xx' = 1$ .

$$H(z, \theta, x) = \frac{1}{V(\mathfrak{C}_{IV}) [(x - e^{-i\theta}z)(x - e^{-i\theta}z)']^{n/2}},$$

the magnitude of the volume  $V(\mathfrak{C}_{IV})$ : 
$$V(\mathfrak{C}_{IV}) = \frac{2\pi^{\frac{n}{2}+1}}{\Gamma\left(\frac{n}{2}\right)}.$$

The Bergman kernel of the domain  $\mathfrak{R}_{IV}$  is

$$\frac{1}{V(\mathfrak{R}_{IV})} (1 + |zz'|^2 - 2\bar{z}z')^{-n},$$

where,  $V(\mathfrak{R}_{IV}) = \frac{\pi^n}{2^{n-1} \cdot n!}.$

THE POISSON KERNEL FOR  $\mathfrak{R}_{IV}$

$$P(z, \xi) = \frac{1}{V(\mathfrak{R}_{IV})} \cdot \frac{(1 + |zz'|^2 - 2\bar{z}z')^{\frac{n}{2}}}{|(z - \xi)(z - \xi)'|^n},$$

where  $\xi \in \mathfrak{E}_{IV}.$

HARMONIC ANALYSIS ON LIE SPHERES

$$\int_{\mathfrak{R}_{IV}} |zz'|^{2l} \Phi_{f-2l}(z, \bar{z}) \bar{z}$$

$$= (N_{f-2l} - N_{f-2l-2}) \frac{l \Gamma(n) \Gamma\left(\frac{n}{2} + 1\right) \Gamma\left(f + \frac{n}{2} - l\right)}{2\pi^{\frac{n}{2}} \Gamma\left(l + \frac{n}{2} + 1\right) \Gamma(f + n - l)} V(\mathfrak{R}_{IV}).$$

...

In Annals of Mathematics 55 (1952) 19-33 P. R. **Garabedian** said “...

we turn here to a more direct development of the theory of boundary value problems associated with the Cauchy-Riemann equations for analytic functions of several complex variables.

This boundary value problem is solved by means of a Dirichlet principle, and we introduce a Green's function in terms of which the solution can be expressed as a boundary integral. A formula giving the Bergman kernel function for several variables [1] in terms of this Green's function is obtained, and we thus generalize known theorems from the theory of functions of one complex variable

for analytic functions of several complex variables.

Bergman [1] defines a kernel function  $k(z, t)$ , analytic in  $z$  and  $\bar{t}$  for  $z, t \in D$

**THEOREM 3.** *The analytic kernel function  $k(z, t)$  with*

$$g(t) = \int_D g(z) \overline{k(z, t)} d\tau$$

for each analytic function  $g$  in  $D$  has the representation

$k(z, t) = \Delta_z \theta(z, t)$  in terms of the Green's function  $\theta(z, t)$ .

...”

E8 Physics constructs the **Lagrangian** integral such that the **mass m emerges as the integral over the Schwinger Source spacetime region** of its Kerr-Newman cloud of virtual particle/antiparticle pairs plus the Valence Fermion so that the volume of the Schwinger Source fermion defines its mass, which, being dressed with the particle/antiparticle pair cloud, gives **quark mass as constituent mass**.

**Armand Wyler used Harmonic Geometry to calculate:**

**Fermion masses** as a product of four factors:

$$V(\text{Qfermion}) \times N(\text{Graviton}) \times N(\text{octonion}) \times \text{Sym}$$

$V(\text{Qfermion})$  is the volume of the part of the half-spinor fermion particle manifold  $S^7 \times \mathbb{R}P^1$  related to the fermion particle by photon, weak boson, or gluon interactions.

$N(\text{Graviton})$  is the number of types of  $\text{Spin}(0,5)$  graviton related to the fermion.

$N(\text{octonion})$  is an octonion number factor relating up-type quark masses to down-type quark masses in each generation.

$\text{Sym}$  is an internal symmetry factor, relating 2nd and 3rd generation massive leptons to first generation fermions. It is not used in first-generation calculations.

**Force Strengths** are made up of two parts:

the relevant spacetime manifold of gauge group global action

the  $U(1)$  photon sees 4-dim spacetime as  $T^4 = S^1 \times S^1 \times S^1 \times S^1$

the  $SU(2)$  weak boson sees 4-dim spacetime as  $S^2 \times S^2$

the  $SU(3)$  weak boson sees 4-dim spacetime as  $CP^2$

the  $\text{Spin}(5)$  of gravity sees 4-dim spacetime as  $S^4$

and

the volume of the Shilov boundary corresponding to the symmetric space with local symmetry of the gauge boson. The nontrivial Shilov boundaries are:

for  $SU(2)$  Shilov =  $\mathbb{R}P^1 \times S^2$

for  $SU(3)$  Shilov =  $S^5$

for  $\text{Spin}(5)$  Shilov =  $\mathbb{R}P^1 \times S^4$

Schwinger Sources as described above are continuous manifold structures of Bounded Complex Domains and their Shilov Boundaries but the E8-Cl(16) model at the Planck Scale has spacetime condensing out of Clifford structures forming a Lorentz Leech lattice underlying 26-dim String Theory of World-Lines with  $8 + 8 + 8 = 24$ -dim of fermion particles and antiparticles and of spacetime.

**The automorphism group of a single 26-dim String Theory cell modulo the Leech lattice is the Monster Group of order about  $8 \times 10^{53}$ .**

The Monster Group is of order  
 8080 , 17424, 79451, 28758, 86459, 90496, 17107, 57005, 75436, 80000, 00000  
 =  
 $2^{46} \cdot 3^{20} \cdot 5^9 \cdot 7^6 \cdot 11^2 \cdot 13^3 \cdot 17 \cdot 19 \cdot 23 \cdot 29 \cdot 31 \cdot 41 \cdot 47 \cdot 59 \cdot 71$   
 or about  $8 \times 10^{53}$

This chart (from Wikipedia) shows the Monster M and other Sporadic Finite Groups

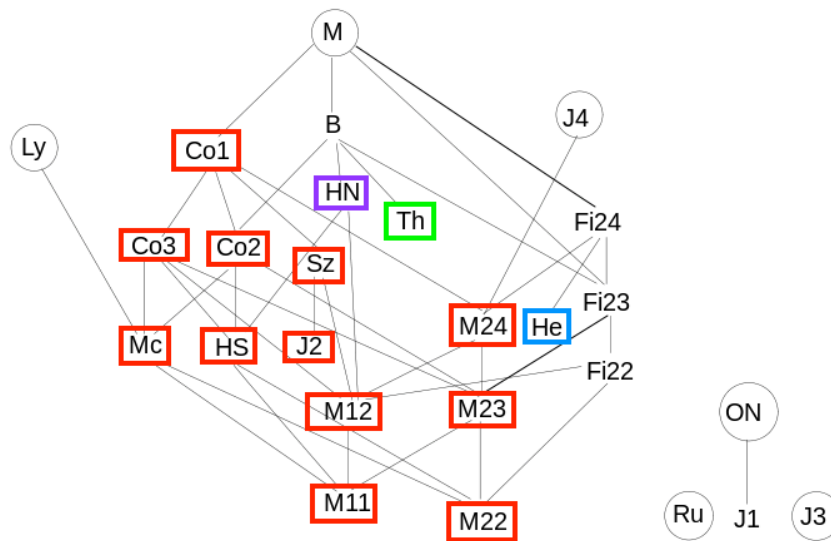

The order of Co1 is  $2^{21} \cdot 3^9 \cdot 5^4 \cdot 7^2 \cdot 11 \cdot 13 \cdot 23$  or about  $4 \times 10^{18}$ .

Aut(Leech Lattice) = double cover of Co1.

The order of the double cover  $2 \cdot \text{Co1}$  is  $2^{22} \cdot 3^9 \cdot 5^4 \cdot 7^2 \cdot 11 \cdot 13 \cdot 23$  or about  $0.8 \times 10^{19}$ .

Taking into account the non-sporadic part of the Leech Lattice symmetry

according to the ATLAS at [brauer.maths.qmul.ac.uk/Atlas/v3/spor/M/](http://brauer.maths.qmul.ac.uk/Atlas/v3/spor/M/)

the Schwinger Source Kerr-Newman Cloud Symmetry  $s 2^{(1+24)} \cdot \text{Co1}$

of order  $139511839126336328171520000 = 1.4 \times 10^{26}$

Co1 and its subgroups account for 12 of the 19 subgroups of the Monster M.

Of the remaining 7 subgroups, Th and He are independent of the Co1 related

subgroups and HN has substantial independent structure.

Th = Thompson Group. Wikipedia says "... Th ... was ... constructed ... as the automorphism group of a certain lattice in the 248-dimensional Lie algebra of E8.

It does not preserve the Lie bracket of this lattice, but

does preserve the Lie bracket mod 3, so is a subgroup of the Chevalley group E8(3).

The subgroup preserving the Lie bracket (over the integers) is a maximal

subgroup of the Thompson group called the Dempwolff group (which unlike the

Thompson group is a subgroup of the compact Lie group E8) ...

the Thompson group acts on a vertex operator algebra over the field with 3 elements.

This vertex operator algebra contains the E8 Lie algebra over  $\mathbf{F}_3$ ,

giving the embedding of Th into E8(3) ...

The Schur multiplier and the outer automorphism group of ... Th ... are both trivial.

Th is a sporadic simple group of order  $215 \cdot 310 \cdot 53 \cdot 72 \cdot 13 \cdot 19 \cdot 31$

$= 90745943887872000 \approx 9 \times 10^{16}$  ...".

He = Held Group. Wikipedia says "... The smallest faithful complex representation has dimension 51; there are two such representations that are duals of each other.

It centralizes an element of order 7 in the Monster group. ...

the prime 7 plays a special role in the theory of the group ...

the smallest representation of the Held group over any field is

the 50 dimensional representation over the field with 7 elements ...

He ... acts naturally on a vertex operator algebra over the field with 7 elements ...

The outer automorphism group has order 2 and the Schur multiplier is trivial. ...

He is a sporadic simple group of order  $210 \cdot 33 \cdot 52 \cdot 73 \cdot 17$

$= 4030387200 \approx 4 \times 10^9$  ...".

HN = Harada-Norton Group. Wikipedia says "... The prime 5 plays a special role ...

it centralizes an element of order 5 in ... the Monster group ...and as a result acts

naturally on a vertex operator algebra over the field with 5 elements ... it acts on

a 133 dimensional algebra over  $\mathbf{F}_5$  with a commutative but nonassociative product ...

Its Schur multiplier is trivial and its outer automorphism group has order 2 ...

HN is a sporadic simple group of order  $2^{14} \cdot 3^6 \cdot 5^6 \cdot 7 \cdot 11 \cdot 19$

$= 273030912000000 \approx 3 \times 10^{14}$  ...

HN has an involution whose centralizer is of the form  $2.HS.2$ , where HS is the Higman-Sims group ... of order  $2^9 \cdot 3^2 \cdot 5^3 \cdot 7 \cdot 11 = 44352000 \approx 4 \times 10^7$  ... [whose] Schur multiplier has order 2 ... [and whose] outer automorphism group has order 2 ... HS is ... a subgroup of ... the Conway groups Co0, Co2 and Co3 ...”.

Co1 x Th x He x HN / HS together have order about  $4 \times 9 \times 4 \times 10^{(18+16+9+7)}$   
 = about  $10^{52}$  which is close to the order of M = about  $10^{54}$ .

The components of the Monster Group describe the composition of Schwinger Sources:

Co1 gives the number of particles in the Schwinger Source Kerr-Newman Cloud emanating from a Valence particle in a Planck-scale cell of E8 Physics SpaceTime.

Th gives the 3-fold E8 Triality structure relating 8-dim SpaceTime to First-Generation Fermion Particles and AntiParticles.

He gives the 7-fold algebraically independent Octonion Imaginary E8 Integral Domains that make up 7 of the 8 components of Octonion Superposition E8 SpaceTime.

HN / HS gives the 5-fold symmetry of 120-element Binary Icosahedral E8 McKay Group beyond the 24-element Binary Tetrahedral E6 McKay Group at which level the Shilov Boundaries of Bounded Complex Domains emerge to describe SpaceTime and Force Strengths and Particle Masses.

**When a fermion particle/antiparticle appears in E8 spacetime** it does not remain a single Planck-scale entity because **Tachyons create a cloud of particles/antiparticles**. The cloud is one Planck-scale Fundamental Fermion Valence Particle plus an effectively neutral cloud of particle/antiparticle pairs forming a Kerr-Newman black hole. That cloud constitutes the **Schwinger Source**. Its **structure comes from the 24-dim Leech lattice part of the Monster Group which is**

**$2^{(1+24)}$  times the double cover of Co1, for a total order of about  $10^{26}$ .**

Since a Leech lattice is based on copies of an E8 lattice and since there are 7 distinct E8 integral domain lattices there are 7 (or 8 if you include a non-integral domain E8 lattice) distinct Leech lattices. The physical Leech lattice is a superposition of them, effectively adding a factor of 8 to the order.

The volume of the Kerr-Newman Cloud is on the order of  $10^{27}$  x Planck scale, so the Kerr-Newman Cloud **Source should contain about  $10^{27}$  particle/antiparticle pairs and its size should be about  $10^{(27/3)} \times 1.6 \times 10^{(-33)}$  cm = roughly  $10^{(-24)}$  cm.**



## Schwinger Source QuasiCrystal Internal Structure

Above the scale of Schwinger Sources (  $10^{-24}$  cm ) E8-CI(16) Physics structures such as Spacetime, Symmetric Spaces, and Bounded Complex Domains and their Shilov Boundaries, are well approximated by smooth manifolds so that the geometric techniques of Amand Wyler give good results for force strengths, particle masses, etc.

Below the scale of Schwinger Sources (  $10^{-24}$  cm down to Planck  $10^{-33}$  cm ) the fundamental structures are E8 lattices and QuasiCrystals derived therefrom. Planck Scale is about  $10^{-33}$  cm. Schwinger Souce Scale is about  $10^{-24}$  cm, a scale about  $10^9$  larger than the Planck Scale.

The 240 E8 Root Vector Vertices of each cell of 8D E8-CI(16) Physics Spacetime can be represented in 2D as done by Ray Aschheim

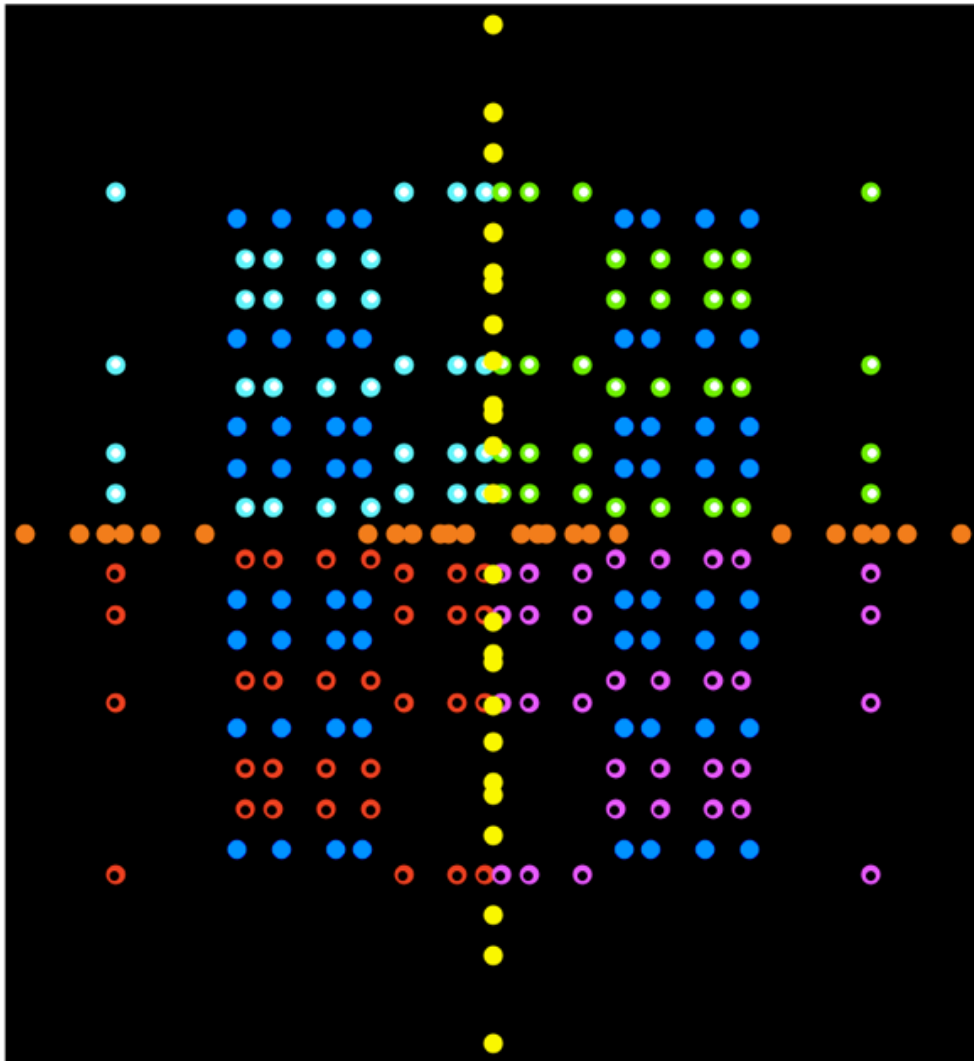

The E8-CI(16) Physical interpretation of the 240 E8 Root Vectors is

## E8 / D8 for 8-dim Spacetime components of 8+8 First-Generation Fermions

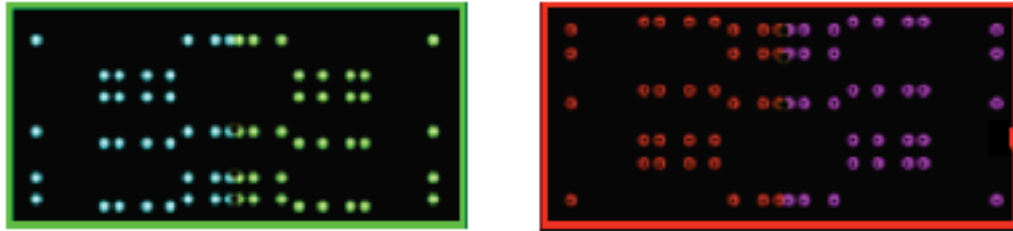

Green and Cyan dots with white centers (32+32 = 8x8 dots)  
for Fermion Particles  
and  
Red and Magenta dots with black centers (32+32 = 8x8 dots)  
for Fermion AntiParticles

## D8 / D4 x D4 for Spacetime Superposition of 8 types of E8 Lattice

The 64 generators (8x8 = 64 blue dots) correspond to an 8-dim base manifold of an E8 Lagrangian in which Spacetime 8V of 26D String Theory is represented by 8-branes whose Planck-Scale Lattice Structure is that of a superposition of 8 types of E8 Lattice: 7 E8 Integral Domains corresponding to the 7 Imaginary Octonion Basis Elements and 1 E8 Lattice (not an Integral Domain - Kirmse's Mistake) corresponding to the Octonion Real Axis. The 64 Blue Root Vectors of the space D8 / D4 x D4 also represent the  $A_{7+1} = SL(8,R)+1$  in the Maximal Contraction Heisenberg Algebra of E8 with structure  $28 + 64 + (A_{7+1}) = 64 + 28$  where  $A_7$  is Unimodular  $SL(8,R)$  Gravity.

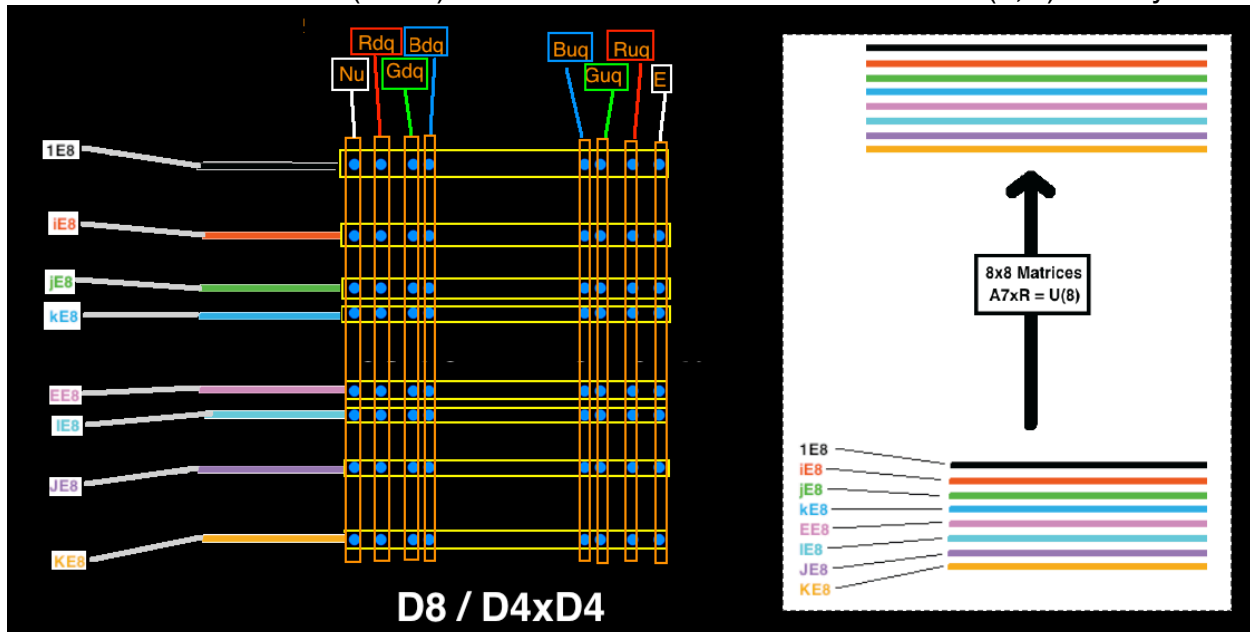

The map from one 8-brane superposition to the next is by 8x8 Matrices representing the central grade-0 part  $A_{7+1}$  of the Heisenberg Maximal Contraction Algebra of E8,

## D4 for Gravity - Dark Energy Gauge Bosons and Standard Model Ghosts

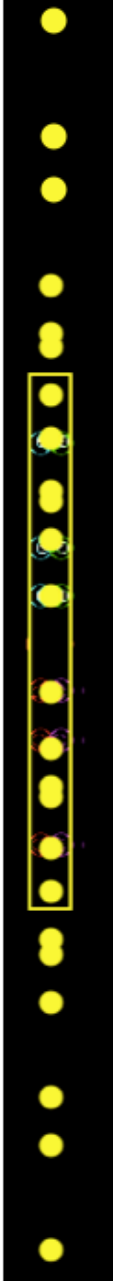

The 24 Yellow Root Vectors of the D4 of E8 Gravity + Standard Model Ghosts are on the Vertical Y-axis.

12 of them in the Yellow Box represent the 12 Root Vectors of the Conformal Gauge Group  $SU(2,2) = Spin(2,4)$  of Conformal Gravity + Dark Energy.

The 4 Cartan Subalgebra elements of  $SU(2,2) \times U(1) = U(2,2)$  correspond to the 4 Cartan Subalgebra elements of D4 of E8 Gravity + Standard Model Ghosts and to the other half of the 8 Cartan Subalgebra elements of E8.

The other  $24 - 12 = 12$  Yellow Root Vectors represent Ghosts of 12D Standard Model whose Gauge Groups are  $SU(3) SU(2) U(1)$ .

Gravity and Dark Energy come from its Conformal Subgroup  $SU(2,2) = Spin(2,4)$   
(see Appendix - Details of Conformal Gravity and ratio DE : DM : OM)

$SU(2,2) = Spin(2,4)$  has 15 generators:

1 Dilation representing Higgs Ordinary Matter

4 Translations representing Primordial Black Hole Dark Matter

10 = 4 Special Conformal + 6 Lorentz representing Dark Energy  
(see Irving Ezra Segal, "Mathematical Cosmology and Extragalactic Astronomy" (Academic 1976))

The basic ratio Dark Energy : Dark Matter : Ordinary Matter =  $10:4:1 = 0.67 : 0.27 : 0.06$   
When the dynamics of our expanding universe are taken into account, the ratio is calculated to be **0.75 : 0.21 : 0.04**

The  $U(1)$  of  $SU(2,2) \times U(1) = U(2,2)$  represents the Propagator Phase Internal Clock

## D4 for Standard Model Gauge Bosons and Gravity - Dark Energy Ghosts

The 24 Orange Root Vectors of the D4 of E8 Standard Model + Gravity Ghosts are on the Horizontal X-axis.



8 of them in the Orange Box represent the 8 Root Vectors of the Standard Model Gauge Groups SU(3) SU(2) U(1).

Their 4 Cartan Subalgebra elements correspond to the 4 Cartan Subalgebra elements of D4 of E8 Standard Model + Gravity Ghosts and to half of the 8 Cartan Subalgebra elements of E8.

The other 24-8 = 16 Orange Root Vectors represent Ghosts of 16D U(2,2) which contains the Conformal Group SU(2,2) = Spin(2,4) that produces Gravity + Dark Energy by the MacDowell-Mansouri mechanism.

Standard Model Gauge groups come from CP2 = SU(3) / SU(2) x U(1)

(as described by Batakis in Class. Quantum Grav. 3 (1986) L99-L105)

Electroweak SU(2) x U(1) is gauge group as isotropy group of CP2.

SU(3) is global symmetry group of CP2 but due to Kaluza-Klein M4 x CP2 structure of compact CP2 at every M4 spacetime point, it acts as Color gauge group with respect to M4.

Here is how the 240 E8 Root Vectors define an 8D Lagrangian:

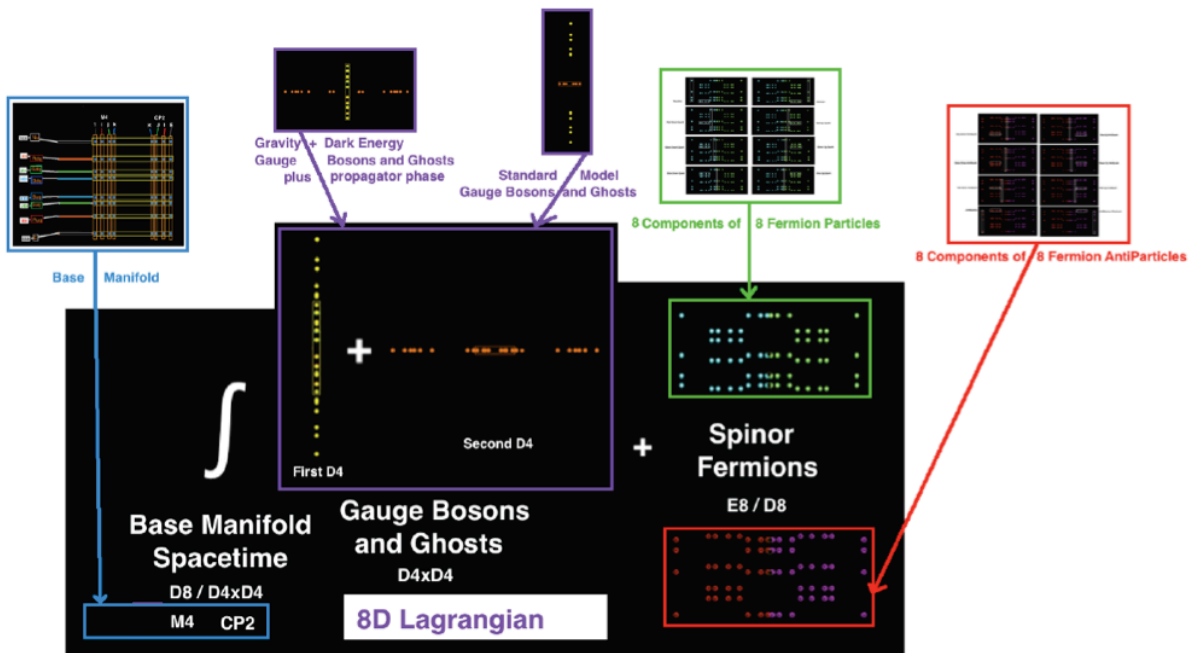

Here is how the 8D Lagrangian goes to 4D Lagrangian of M4 x CP2 Kaluza-Klein so that the Higgs and Fermion Generations 2 and 3 emerge:

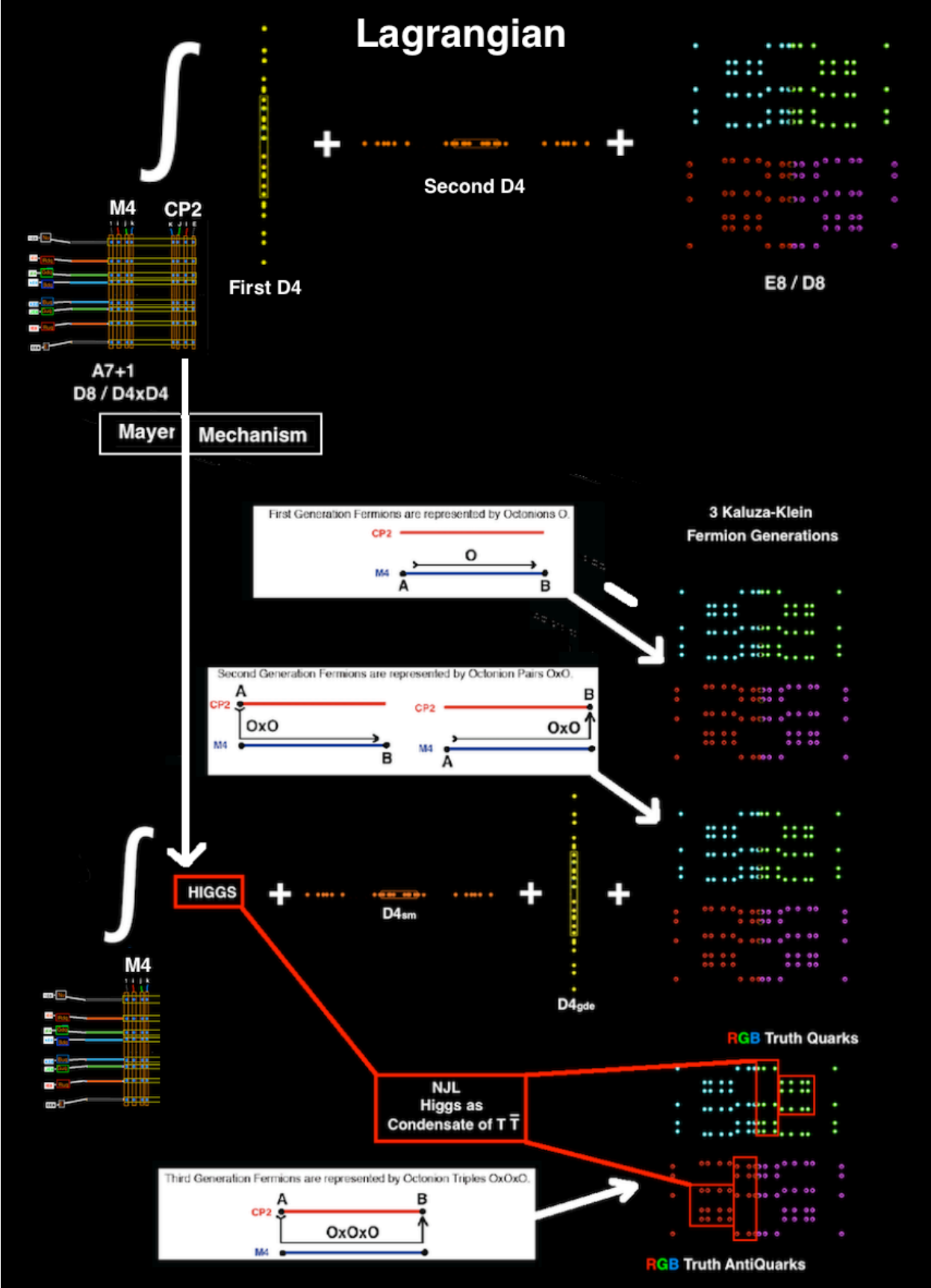

This mapping of the shell structure of a full E8 Lattice is adapted from the book "Geometrical Frustration" by Sadoc and Mosseri

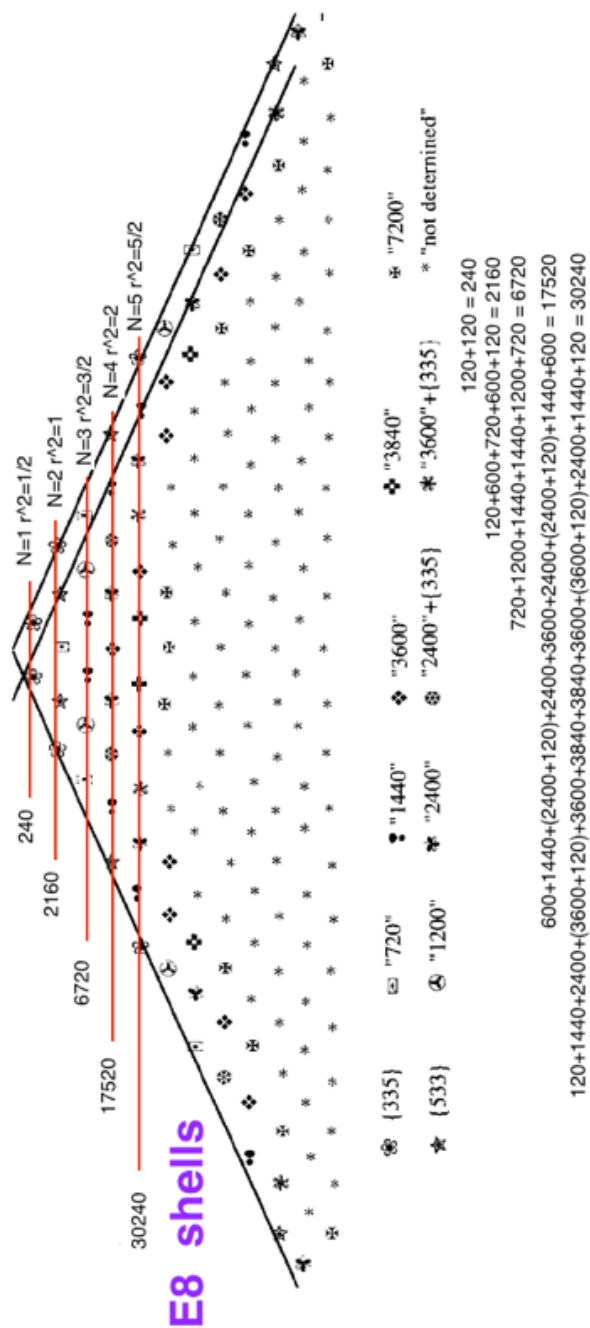

**If you consider only the Root Vectors neighboring the Origin of the Lattices,**  
 that is, only the first Lattice shell, then you see that  
 the 240 Root Vectors of E8 are made up of two copies of the 120 Root Vectors of H4

One H4 describes the Standard Model and is related to CP2 of M4 x CP2 Kaluza-Klein.

The other describes Conformal Gravity + Dark Energy and U(1) Propagator Phase  
 and is related to M4 of M4 x CP2 Kaluza-Klein.

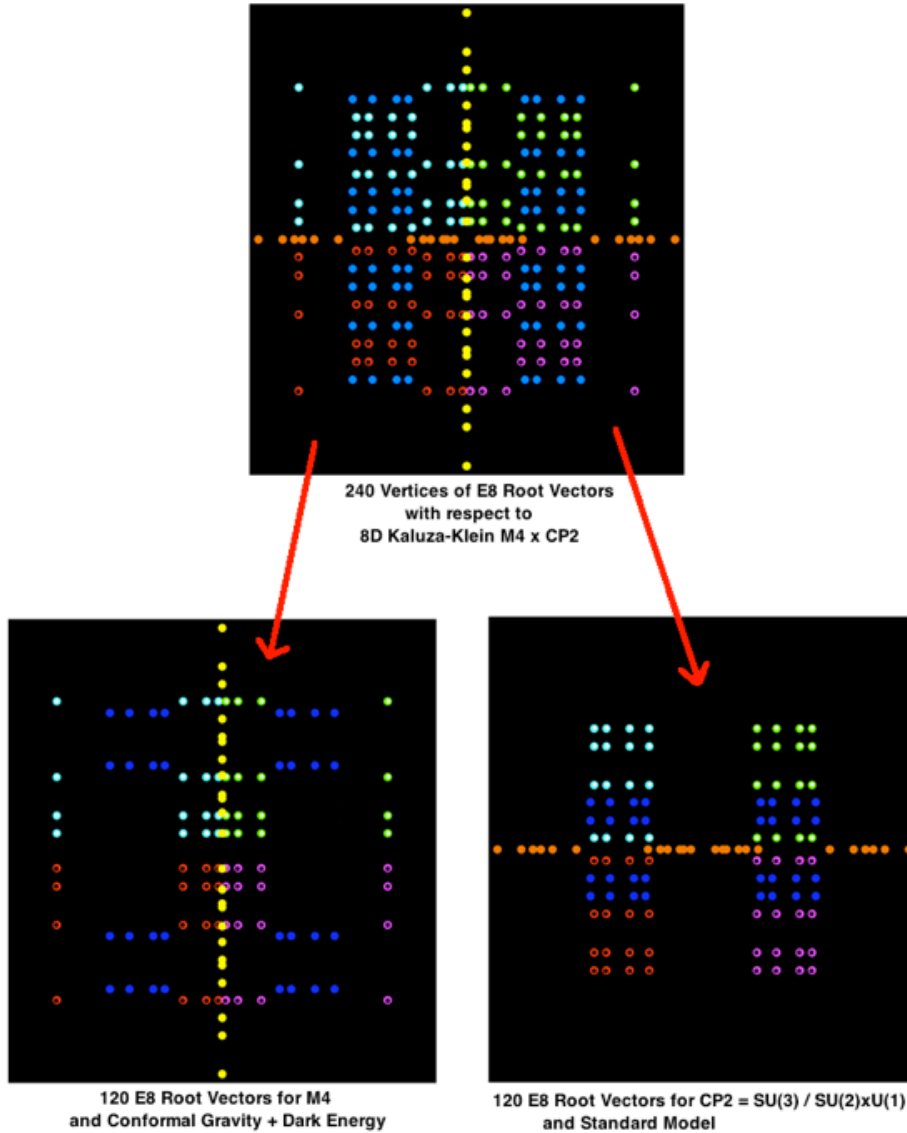

The 120 Root Vectors for H4 tiling of M4 Minkowski Physical Spacetime (H4 M4)  
 and  
 the 120 Root Vectors for H4 tiling of CP2 Internal Symmetry Space (H4 CP2)  
 form two 600-cells, one with Golden Ratio edge length (define it to be for M4)  
 and the other with Unit edge length (define it to be for CP2)

To see the internal structure of a Schwinger Source look at the M4 part of M4 x CP2 Kaluza-Klein Spacetime and choose a Fermion Type whose Schwinger Source structure you want to see (for example, Electron).

First, chose only those E8 Lattice vertices with CP2 coordinates = zero so that you have only M4 coordinates being non-zero. Here is a schematic diagram of how E8 Lattice breaks down into H4 CP2 Lattice and H4 M4 Lattice

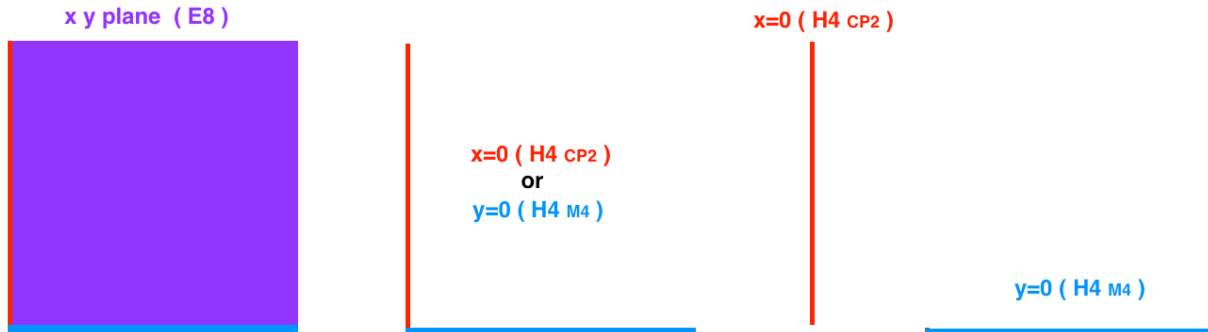

Then project from 8D E8 Lattice space to 4D H4 Lattice space for M4 in which each 4D H4 Lattice vertex is surrounded by 120 vertices at Golden Ratio distance from the origin point.

Then select the Fermion (Electron in this example) that is located at the M4 coordinates of the origin point.

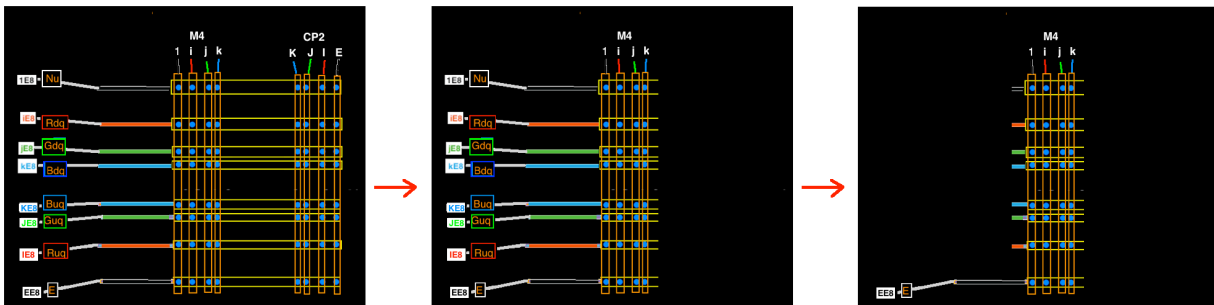

The image on the far right is the representation of

**a Valence Electron at the M4 coordinates of the origin point**

which is surrounded by its 120 nearest-neighbor vertices which are all at Golden Ratio distance and which form a 600-cell



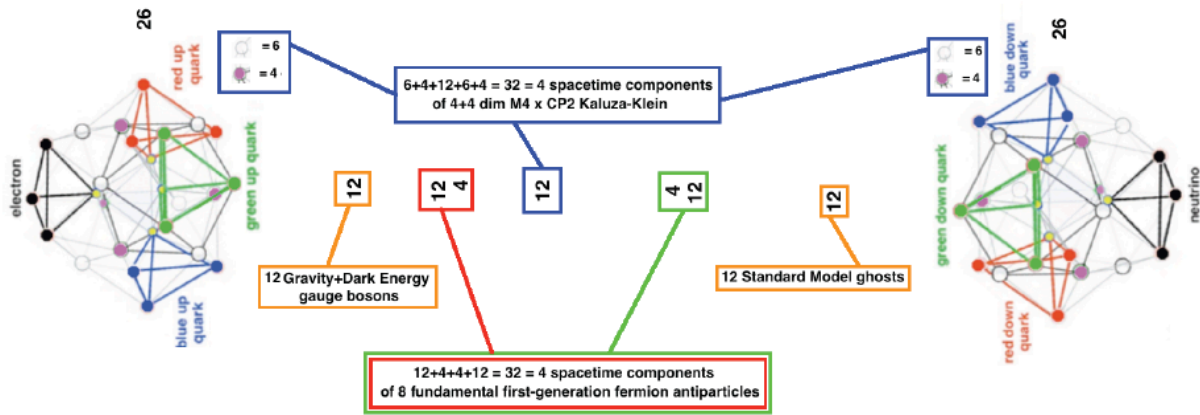

in which the Electron and its M4 coordinates are represented by the Tetrahedron of 4 vertices at the top (far left) of the 600-cell.

A more detailed view how full E8 Lattice breaks down into full H4 CP2 Qiasicrystal Lattice and full H4 M4 Quasicrystal Lattice is shown on the following page, where you can see some interesting phenomena, such as:

The E8 lattice (interior of the diagram) is periodic, a property inherited from its 8-dimensional structure.

Both the H4 M4 and H4 CP2 Lattices are Fibonacci-type Quasicrystals with chain structure L S L L S L S L L S ... inherited from the fact that some E8 lattice lines are longer than the preceding line by 2 and others are longer by 4.

All the things in the H4 M4 Fibonacci Chain are Golden Ratio larger than the corresponding things in the H4 CP2 Fibonacci Chain.

The H4 CP2 Quasicrystal determines the Standard Model Internal Symmetry of its Schwinger Source through  $CP2 = SU(3) / SU(2) \times U(1)$ .

The H4 M4 Quasicrystal determines the Spacetime Properties, including filling the volume, of the Schwinger Source through the Conformal  $U(2,2)$  symmetry.

The size and volume of the Schwinger Source ( $10^{-24}$  cm and  $10^{27}$  particle-antiparticle pairs) is imposed on the H4 M4 Quasicrystal by the Monster symmetry of Lattice Spacetime at the Planck scale, and then imposed on the H4 CP2 Quasicrystal by symmetry with H4 M4.

The Indra Net mirroring ability of each of the  $10^{27}$  virtual elements of a Schwinger Source is of the order of the Monster Group of the Spacetime Lattice Cell of the Valence H4 M4 600-cell which is on the order of  $10^{53}$ , so that the total mirroring capacity of a single Schwinger Source is  $10^{27} \times 10^{53} = 10^{80}$  which is enough mirroring capacity to maintain an Indra's Net Blockchain System of all the particles in Our Universe.

H4 CP2

H4 M4

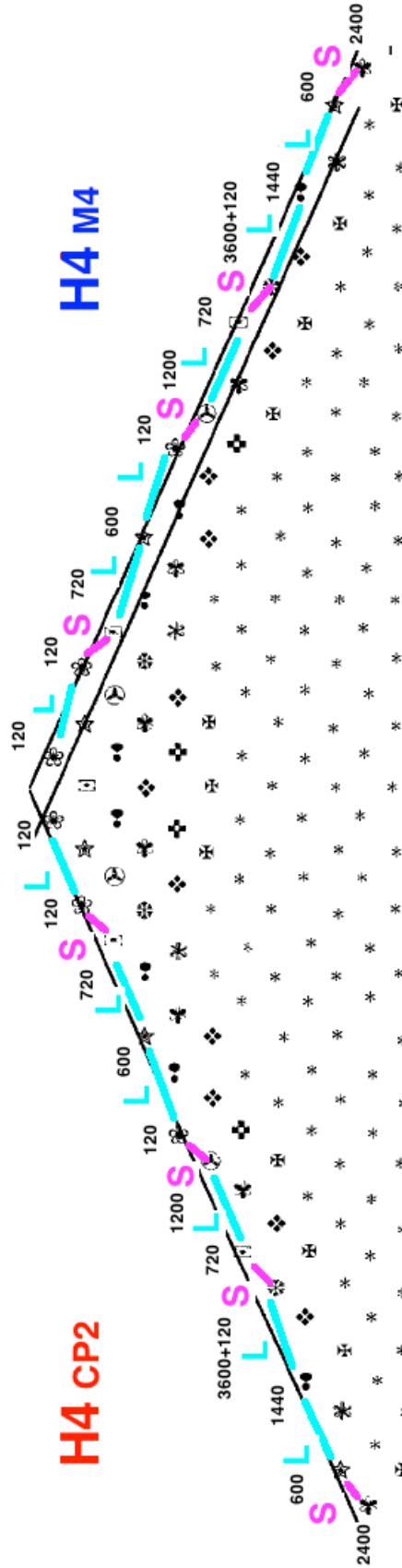

E8

- ☼ {335}    ☐ "720"    ⚙ "1440"    ⚙ "3600"    ⚙ "7200"
- ★ {533}    ⚙ "1200"    ⚙ "2400"    ⚙ "2400"+{335}    ⚙ "3840"    ⚙ "3600"+{335}    ⚙ "not determined"

## Indra's Net of Schwinger Sources

Each Schwinger Source particle-antiparticle pair should see (with Bohm Potential) the rest of our Universe in the perspective of  $8 \times 10^{53}$  Monster Symmetry so a **Schwinger Source acting as a Jewel of Indra's Net** of Schwinger Source Bohm Quantum Blockchain Physics (viXra 1801.0086 )  
**can see / reflect  $10^{27} \times 8 \times 10^{53} = 8 \times 10^{80}$  Other Schwinger Source Jewels of Indra's Net.**

### How many Schwinger Sources are in the Indra's Net of Our Universe ?

Based on gr-qc/0007006 by Paola Zizzi, the Inflation Era of Our Universe ended with Quantum Decoherence when its number of qubits reached  $2^{64}$  for  $Cl(64) = Cl(8)^8$  self-reflexivity whereby each  $Cl(8)$  8-Periodicity component corresponded to each basis element of the  $Cl(8)$  Vector Space.

At the End of Inflation, each of the  $2^{64}$  qubits transforms into  $2^{64}$  elementary first-generation fermion particle-antiparticle pairs. The resulting  $2^{64} \times 2^{64}$  pairs constitute a Zizzi Quantum Register of order  $2^{64} \times 2^{64} = 2^{128}$ .

At Reheating time  $T_n = (n+1) T_{Planck}$  the Register has  $(n+1)^2$  qubits so at Reheating Our Universe has  $(2^{128})^2 = 2^{256} = 10^{77}$  qubits and since each qubit corresponds to fermion particle-antiparticle pairs that average about 0.66 GeV so

**the number of particles in our Universe at Reheating is about  $10^{77}$  nucleons which, being less than  $10^{80}$ , can be reflected by Schwinger Source Indra Jewels.**

The Reheating process raises the energy/temperature at Reheating to  $E_{reh} = 10^{14}$  GeV, the geometric mean of the  $E_{Planck} = 10^{19}$  GeV and  $E_{decoh} = 10^{10}$  GeV.

After Reheating, our Universe enters the Radiation-Dominated Era, and, since there is no continuous creation, particle production stops, so the  **$10^{77}$  nucleon Baryonic Mass of our Universe has been mostly constant since Reheating**

## Indra's Net

"... "Indra's net" is the net of the Vedic deva Indra, whose net hangs over his palace on Mount Meru, the axis mundi of Buddhist and Hindu cosmology. In this metaphor, Indra's net has a multifaceted jewel at each vertex, and each jewel is reflected in all of the other jewels ... the image of "Indra's net" is used to describe the interconnectedness of the universe ... Francis H Cook describes Indra's net thus:  
"Far away in the heavenly abode of the great god Indra, there is a wonderful net ... a single glittering jewel in each "eye" of the net ... in ... each of the jewels ... its polished surface ... reflect[s] all the other jewels in the net ... Not only that, but each of the jewels reflected in this one jewel is also reflecting all the other jewels ..."

Image from <https://brightwayzen.org/meetings-placeholder/indras-net-honoring-interdependence-scales/> :

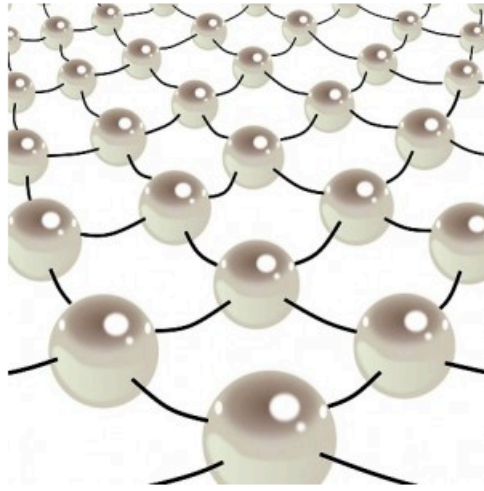

In E8-Cl(16) Physics each Indra Jewel is a Schwinger Source.

### 26D Freudenthal Fr3(O) String Theory - Bohm Quantum Potential

To understand **Schwinger Sources of E8 Physics start with 26D String Theory:**  
interpret **Strings as World-Lines** of Particles and  
**spin-2 String Theory 24x24 symmetric matrices**  
**as carriers of Bohm Quantum Potential** (not gravitons).

Luis E. Ibanez and Angel M. Uranga in “String Theory and Particle Physics” said:  
“... String theory proposes ... small one-dimensional extended objects, strings,  
of typical size  $L_s = 1/M_s$ , with  $M_s$  known as the string scale ...  
As a string evolves in time, it sweeps out a two-dimensional surface in spacetime,  
known as the worldsheet, which is the analog of the ... worldline of a point particle ...  
for the bosonic string theory ... the classical string action is the total area spanned by  
the worldsheet ... This is the ... Nambu– Goto action ...”.

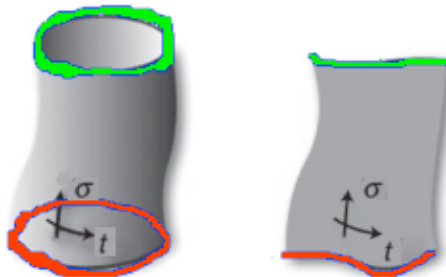

( images adapted from “String Theory and Particle Physics” by Ibanez and Uranga )  
In my unconventional view the red line and the green line are different strings/  
worldlines/histories and the world-sheet is the minimal surface connecting them,  
carrying the Bohm Potential.

The  $t$  world-sheet coordinate is for Time of the string-world-line history.

The  $\sigma$  world-sheet coordinate is for Bohm Potential Gauge Boson at a given Time.

Further, Ibanez and Uranga also said:

“... The string ground state corresponds to a 26d spacetime tachyonic scalar field  $T(x)$ . This tachyon ... is ... unstable

...

The massless two-index tensor splits into irreducible representations of  $SO(24)$  ... Its trace corresponds to a scalar field, the dilaton  $\phi$ , whose vev fixes the string interaction coupling constant  $g_s$

...

the antisymmetric part is the 26d 2-form field  $BMN$

...

**The symmetric traceless part is the 26d graviton  $GMN$  ...”.**

**My interpretation of the symmetric traceless part differs from that of Ibanez and Uranga in that it is the carrier of the Bohm Quantum Potential.**

Closed string tachyons localized at orbifolds of fermions produce virtual clouds of particles / antiparticles that dress fermions.

Dilatons are Goldstone bosons of spontaneously broken scale invariance that (analogous to Higgs) go from mediating a long-range scalar gravity-type force to the nonlocality of the Bohm-Sarfatti Quantum Potential.

The antisymmetric  $SO(24)$  little group is related to the Monster automorphism group that is the symmetry of each cell of Planck-scale local lattice structure.

Joe Polchinski in “String Theory, Volume 1, An Introduction to the Bosonic String” said: “... we find at  $m^2 = -4/\alpha'$  the tachyon, and at  $m^2 = 0$  the  $24 \times 24$  states of the graviton, dilaton, and antisymmetric tensor ...”.

**My interpretation of what Polchinski describes as the graviton differs from that of Polchinski in that it is the carrier of the Bohm Quantum Potential.**

The  $24 \times 24$  Real Symmetric Matrices form the Jordan Algebra  $J(24, \mathbb{R})$ .

$24$ -Real-dim space has a natural Octonionic structure of  $3$ -Octonionic-dim space.

The corresponding Jordan Algebra is  $J(3, \mathbb{O}) = 3 \times 3$  Hermitian Octonion matrices.

**Their 26-dim traceless part  $J(3, \mathbb{O})_0$  describes the 26-dim Bosonic String Theory and the algebra of its Quantum States, so that**

**the  $24 \times 24$  traceless symmetric spin-2 particle is the Quantum Bohmion that carries the Bohm Quantum Potential for interactions among Strings = World-Line Histories of Schwinger Sources.**

## Blockchain Structure of Bohm Quantum Potential

Andrew Gray in arXiv quant-ph/9712037 said:

“... probabilities are ... assigned to entire fine-grained histories ...  
base[d] ... on the Feynman path integral formulation ...”

so in E8 Physics the Indra's Net of Schwinger Source Jewels

would not have Bohm Quantum Potential interactions between two Jewels,  
rather **the interactions would be between the two entire World-Line History Strings**



( image adapted from <http://www.blockchaintechnologies.com/> )

According to <https://hbr.org/2017/01/the-truth-about-blockchain> “... **How Blockchain Works ...**

### 1. Distributed Database

Each party on a blockchain has access to the entire database and its complete history. No single party controls the data or the information. Every party can verify the records of its transaction partners directly, without an intermediary.

### 2. Peer-to-Peer Transmission

Communication occurs directly between peers instead of through a central node. Each node stores and forwards information to all other nodes.

### 3. Transparency with Pseudonymity

Every transaction and its associated value are visible to anyone with access to the system. Each node, or user, on a blockchain has a unique 30-plus-character alphanumeric address that identifies it. Users can choose to remain anonymous or provide proof of their identity to others. Transactions occur between blockchain addresses.

### 4. Irreversibility of Records

Once a transaction is entered in the database and the accounts are updated, the records cannot be altered, because they're linked to every transaction record that came before them (hence the term “chain”). Various computational algorithms and approaches are deployed to ensure that the recording on the database is permanent, chronologically ordered, and available to all others on the network.

## 5. Computational Logic

The digital nature of the ledger means that blockchain transactions can be tied to computational logic and in essence programmed. So users can set up algorithms and rules that automatically trigger transactions between nodes. ...”.

With respect to Bohm Quantum Potential of E8 Physics Schwinger Sources there is no Human directly controlling any Event / Interaction / Transaction, as they are all completely controlled by the Laws of Physics which define “algorithms and rules that automatically trigger transactions between nodes” .

**Each Node is a Schwinger Source that is connected by Bohm Quantum Potential to all other Schwinger Source Nodes in our Universe and governed by the “algorithms and rules” of the E8 Physics Lagrangian and the Algebraic Quantum Field Theory arising from the completion of the union of all tensor products of copies of  $Cl(16)$  each copy of  $Cl(16)$  containing E8 and the E8 Lagrangian.**

According to <http://www.blockchaintechnologies.com/> “... A blockchain is a type of distributed ledger, comprised of unchangable, digitally recorded data in packages called *blocks*. These digitally recorded "blocks" of data is stored in a linear *chain* ...



... A distributed ledger is a consensus of replicated, shared, and synchronized digital data geographically spread across multiple sites, countries, and/or institutions ...”

**or, in the case of the E8 Physics Indra’s Net of Schwinger Source Jewels, spread across the entirety of our Universe.**

The idea of Schwinger Sources as more than mere points is in David Finkelstein’s Space-Time Code 1968 in which David said “... “... What is too simple about general relativity is the space-time point ... each point of space-time is some kind of assembly of some kind of thing ... Each point, as Feynman once put it, has to remember with precision the values of indefinitely many fields describing many elementary particles; has to have data inputs and outputs connected to neighboring points; has to have a little arithmetic element to satisfy the field equations; and all in all might just as well be a complete computer ...”.

## Results of E8 Physics Calculations:

Here is a summary of E8 Physics model calculation results. Since ratios are calculated, values for one particle mass and one force strength are assumed. Quark masses are constituent masses. Most of the calculations are tree-level, so more detailed calculations might be even closer to observations.

Fermions as Schwinger Sources have geometry of Complex Bounded Domains with Kerr-Newman Black Hole structure size about  $10^{(-24)}$  cm.

( for calculation details see viXra 1804.0121 )

**Dark Energy : Dark Matter : Ordinary Matter = 0.75 : 0.21 : 0.04**

Particle/Force	Tree-Level	Higher-Order
e-neutrino	0	0 for nu <sub>1</sub>
mu-neutrino	0	$9 \times 10^{(-3)}$ eV for nu <sub>2</sub>
tau-neutrino	0	$5.4 \times 10^{(-2)}$ eV for nu <sub>3</sub>
electron	0.5110 MeV	
down quark	312.8 MeV	charged pion = 139 MeV
up quark	312.8 MeV	proton = 938.25 MeV
		neutron - proton = 1.1 MeV
muon	104.8 MeV	106.2 MeV
strange quark	625 MeV	
charm quark	2090 MeV	
tauon	1.88 GeV	
beauty quark	5.63 GeV	
truth quark (low state)	130 GeV	(middle state) 174 GeV (high state) 218 GeV
W+	80.326 GeV	
W-	80.326 GeV	
W0	98.379 GeV	Z0 = 91.862 GeV
Mplanck	$1.217 \times 10^{19}$ GeV	
Higgs VEV (assumed)	252.5 GeV	
Higgs (low state)	126 GeV	(middle state) 182 GeV (high state) 239 GeV
Gravity Gg (assumed)	1	
(Gg)(Mproton <sup>2</sup> / Mplanck <sup>2</sup> )		$5 \times 10^{(-39)}$
EM fine structure	1/137.03608	
Weak Gw	0.2535	
Gw(Mproton <sup>2</sup> / (Mw+ <sup>2</sup> + Mw- <sup>2</sup> + Mz0 <sup>2</sup> ))		$1.05 \times 10^{(-5)}$
Color Force at 0.245 GeV	0.6286	0.106 at 91 GeV
Kobayashi-Maskawa parameters for W+ and W- processes are:		
	d	s
u	0.975	0.222
c	-0.222 -0.000161i	0.974 -0.0000365i
t	0.00698 -0.00378i	-0.0418 -0.00086i
		b
		0.00249 -0.00388i
		0.0423
		0.999
The phase angle d13 is taken to be 1 radian.		



## E8 Physics:

Higgs and Truth Quark = 3-Mass-State Nambu-Jona-Lasinio System:

Higgs at 125 GeV and Truth Quark at 130 GeV

Higgs at 200 GeV and Truth Quark at 174 GeV

Higgs at 250 GeV and Truth Quark at 220 GeV

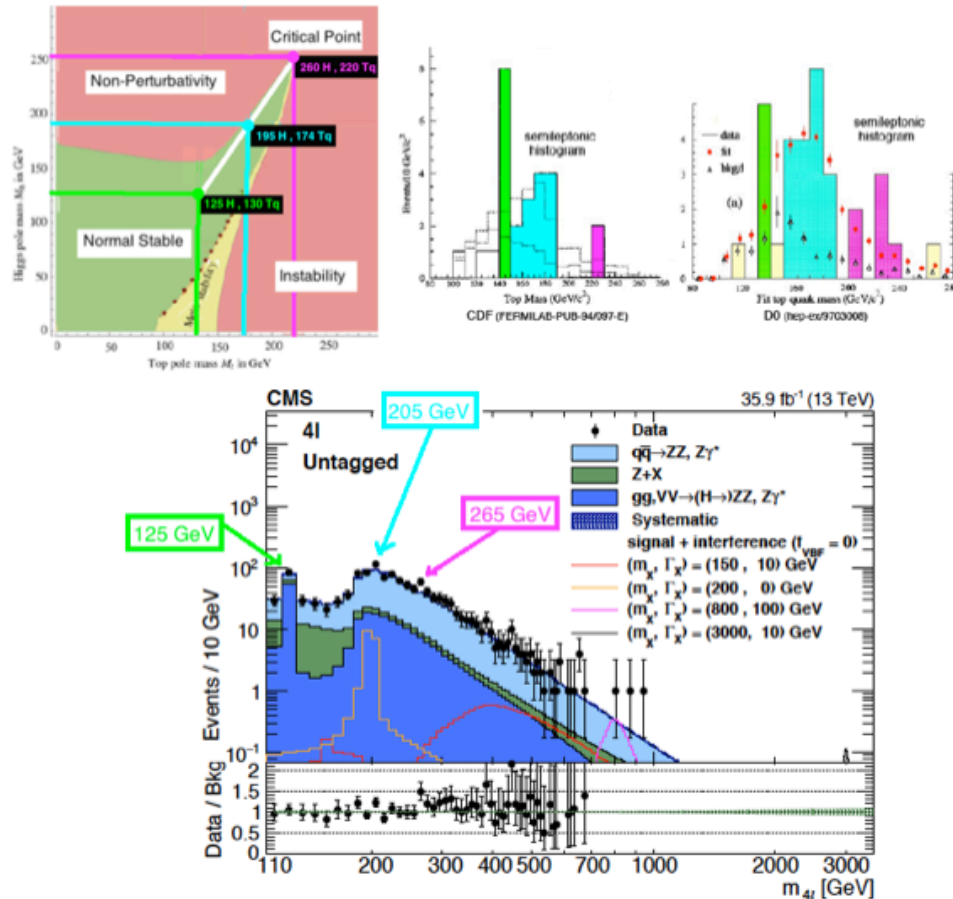

Upper Left = Higgs-Truth Quark mass state phase diagram

Upper Center = CDF semileptonic histogram of 3 Truth Quark Mass States  
FERMILAB-PUB-94/097E

Upper Right = D0 semileptonic histogram of 3 Truth Quark Mass States  
hep-ex/9703008

Lower = CMS  $H \rightarrow ZZ^* \rightarrow 4l$  histogram of 3 Higgs Mass States  
arXiv 1804.01939

Detailed Reference: <http://vixra.org/pdf/1712.0344v5.pdf>

# Appendix: Angkor Wat and Giza Pyramids-Sphinx

**African IFA** =  $16 \times 16 = 2^8 = 256$  Odu = 256 Elementary Cellular Automata =  $CI(8)$   
 Tensor Product  $CI(8) \times CI(8) = CI(16)$  which contains E8 and  $Fr3(O)$   
 and An

**About 50,000 years ago (National Geographic Genographic)**  
**YAP and M174 went out of Africa to Sunda**  
**(then dry land South of Angkor Wat**  
**and SouthEast of India)**  
**and on to Japan and Tibet**



Angkor Wat =  $4 \times 4 = 16$     Angkor Thom =  $16 \times 16 = 256 = \text{sqrt}(65,536)$   
 Wat and Thom have 8-level ( $2^8 = 256$ ) Central Towers  
 Phnom Bakheng is 7-level Mt. Meru with 5 Top-level Sanctuaries

When M174 arrived at Angkor Wat they realized that they were far from Africa so, since they could not communicate easily with the African Elders about IFA, they decided to preserve knowledge of IFA in a written Language. To do that, they invented Sanskrit and wrote Earth's First Book, the Rig-Veda. According to Feuerstein, Kak, and Frawley in their book "In Search of the Cradle of Civilization" "... the Rig-Veda mentions a stellar configuration that corresponds to a date from 6000 B.C. to 7000 B.C. ..." which, due to the Precession of the Equinoxes cycle of about 26,000 years, would also occur from about 34,000 to 35,000 years ago, which is close to Manetho's date of 36,525 years ago for the beginning of the Rule of Gods.

Rig Veda encodes the 240 Root Vectors of E8 = 24+24+64+64+64

Ahankar	Buddhi	Manas	Akash	Vayu	Agni	Jal	Prithivi	Ahankar	Buddhi	Manas	Akash	Vayu	Agni	Jal	Prithivi	Ahankar	Buddhi	Manas	Akash	Vayu	Agni	Jal	Prithivi
अक	नि	मी	ळे	पु	रो	हि	तं	यु	ज्ञ	स्यं	दे	व	मू	त्वि	जंम	हो	ता	रं	रं	लु	धा	तं	मम्
AK	NI	MI	LE	PU	RO	HI	TAM	YA	GVA	SYA	DE	VA	MRI	TVI	JAM	HO	TA	RAM	RA	TNA	DHA	TA	MAM
अ	मिः	पू	वै	पिः	अ	वि	धि	री	ड	यो	तू	तं	नै	तु	त	स	डे	चौ	ए	ह	वै	च	ति
अ	मिः	नो	रु	पिः	मं	वन	व	लो	धं	मे	व	दि	वे	दि	त	यु	श	सै	खी	र	वं	त	मम्
अ	मिः	यो	यु	ज्ञ	मं	ध्व	रं	वि	क्ष	तं	प	पि	धु	रं	मिः	स	इ	इ	डे	के	ग	च्छ	ति
अ	मिः	हो	वां	क	वि	कं	रुः	सु	त्यश्	त्रि	त्र	त्रं	व	स्त	मः	डे	वो	डे	वे	पि	रा	नं	मत्
य	द	ङ्	दा	शु	षे	लु	व	अ	मे	म	त्र	क	रि	व्य	सिः	त	वेत्	तत्	सु	त्य	चं	ङ्गि	रः
उ	धं	त्वा	प्रे	दि	वे	दि	वे	दो	धां	व	स्तर	धि	या	वु	यम्	न	मो	म	रं	लु	ए	मं	सि
रा	वं	न	म	ध्व	रा	शौ	मो	पा	मु	त	स्यु	दी	दि	वि	म्	व	धै	मा	मुं	सु	वे	द	धं
स	नः	पि	ते	व	सु	न	वे	अ	मं	सु	धा	यु	नो	वं	व	स	वं	सु	आ	नः	स्व	स्त	धं

24 First Richa Syllables + 24 First Richa Gaps = D4sm + D4gde (purple box)

8x8 = 64 Last-8 Syllables of Last 8 Lines = D8 / D4sm x D4gde (blue box)

8x8 = 64 First-8 Syllables of Last 8 Lines (green box)

and

8x8 = 64 Middle-8 Syllables of Last 8 Lines (red box)

give 128 = E8 / D8 = Fermion Particles and AntiParticles

According to **The Constitution of the Universe by Maharishi Mahesh Yogi**, printed in newspapers including The Sunday Times (15 March 1992), The Sunday Telegraph (15 March 1992) Financial Times (16 March 1992), The Guardian (16 March 1992), The Wall Street Journal (6 January 1992), and The Washington Post (9 January 1992), a copy of which was sent to me in pamphlet form by John Small in August 2003:

"... modern science has systematically revealed deeper layers of order in nature, from the atomic to the nuclear and subnuclear levels of nature's functioning ...

... the ancient Vedic wisdom ... identifies a single, universal source of all orderliness in nature ...

Both understandings, modern and ancient, locate the unified source of nature's perfect order in a single, self-interacting field of intelligence at the foundation of all the laws of nature. ... The self-interacting dynamics of this unified field constitutes the most basic level of nature's dynamics ... The laws governing the self-interacting dynamics of the unified field can therefore be called the **Constitution of the Universe** ... In Maharishi's Vedic Science, ... the Constitution of the Universe ... is embodied in the very structure of the sounds of the Rik Ved, the most fundamental aspect of the Vedic literature ... According to Maharishi's Apaurusheya Bhashya, the structure of the Ved provides its own commentary - a commentary which is contained in the sequential unfoldment of the Ved itself in its various stages of expression. The knowledge of the total Ved ... is contained in the first sukt of the Rik Ved ...

... The precise sequence of sounds is highly significant; it is in the sequential progression of sound and silence that the true meaning and content of the Ved reside - not on the level of intellectual meanings ascribed to the Ved in the various translations.

The complete knowledge of the Ved contained in the first sukt (stanza) is also found in the first richa (verse) - the first twenty-four syllables of the first sukt (stanza 1). This complete knowledge is again contained in the first pad, or first eight syllables of the first richa, and is also found in the first syllable of the Ved, 'AK', which contains the total dynamics of consciousness knowing itself.

According to Maharishi's Apaurusheya Bhashya of the Ved,

- 'AK' describes the collapse of the fullness of consciousness (A) within itself to its own point value (K). This collapse, which represents the eternal dynamics of consciousness knowing itself, occurs in eight successive stages.
- In the next stage of unfoldment of the Ved, these eight stages of collapse are separately elaborated in the eight syllables of the first pad, which emerges from, and provides a further commentary on, the first syllable of Rik Ved, 'AK'. These eight syllables correspond to the eight 'Prakritis' (Ahamkar, etc.) or eight fundamental qualities of intelligence ...
- The first line, or 'richa', of the first sukt, comprising 24 syllables, provides a further commentary on the first pad (phrase of eight syllables);
  - The first pad expresses the eight Prakritis ... with respect to the knower ... observer ... or 'Rishi' quality of pure consciousness.
  - The second pad expresses the eight Prakritis with respect to the process of knowing ... process of observation ... of 'Devata' (dynamism) quality of pure consciousness.
  - The third pad expresses the eight Prakritis with respect to the known ... observed ... or 'Chhandas' quality of pure consciousness. ... [compare the 3 pads with [Triality](#)]
- The subsequent eight lines complete the remainder of the first sukt - the next stage of sequential unfoldment of knowledge in the Ved. These eight lines consist of 24 padas (phrases), comprising  $8 \times 24 = 192$  syllables. ... these 24 padas of eight syllables elaborate the unmanifest, eight-fold structure of the 24 gaps between the syllables of the first richa (verse). ... Ultimately, in the subsequent stages of unfoldment, these 192 syllables of the first sukt (stanza) get elaborated in the 192 suktas that comprise the first mandal (circular cyclical eternal structure) of the Rik Ved, which in turn gives rise to the rest of the Ved and the entire Vedic literature. ...".

Note that

- the first richa of the first sukt has 24 syllables plus 24 gaps (if you include a silent gap at the beginning/end to close the first sukt into a circle) and
- those 24 gaps are made relevant by being elaborated by the following 8 richas of the first sukt, which have 192 syllables

so that **the total number of relevant entities in the first sukt is  $24+24+192 = 240$** , which is the number of vertices of **the root vector polytope of E8**.

**36,000 Years Ago** - National Geographic Genographic YDNA -  
M168 - YAP - M96 - **M35 Humans follow North Star Vega up the Nile to Giza and Mediterranean**



This coincided with the beginning of Egyptian History according to Manetho (working under Alexander's General and successor Ptolemy I):

**36,525 years ago - Rule of Gods - North Star Vega - Geminga Shock Wave - Glaciation**

22,625 years ago - Rule of Demigods - last Glacial Maximum

17,413 years ago - Rule of Spirits of the Dead - end of last Glacial Maximum

11,600 years ago - Rule of Mortal Humans - North Star Vega - Vela X - end of Ice Age

When Humans reached Giza they built

**two large Pyramids - one for F4gde and one for F4sm - and the Sphinx**

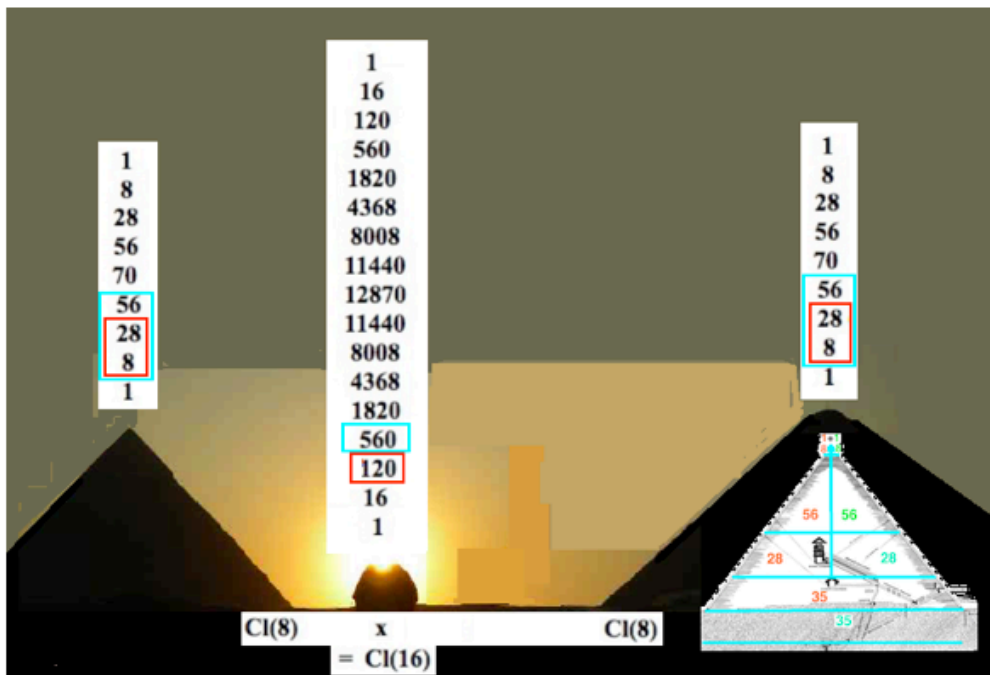

Each Pyramid represented a copy of **Cl(8)** with graded structure

$$256 = 1 + 8 + 28 + 56 + 70 + 56 + 28 + 8 + 1 = (8L+8R) \times (8L+8R)$$

so that each contained a copy of 56-dim Fr3(O)

$$\text{and of } 52\text{-dim } F4 = 8 + 28 + (8L+8R)$$

By 8-Periodicity of Real Clifford Algebras the tensor product **Cl(8) x Cl(8) = Cl(16)**

Cl(16) contains 10 copies of Fr3(O) = 1x56 + 8x28 + 28x8 + 56x1 = 560 elements related to 26D World-Line=String Theory

**Cl(16) contains (1x28 + 8x8 + 28x1 = 120 ) + ( 8Lx8L + 8Rx8R = 128 ) = 248-dim E8**

248-dim E8 structure came from the F4gde and F4sm of the two Pyramids:

$$\text{tensor product } Cl(16) = Cl(8) \times Cl(8)$$

induces the product

$$E8 = F4gde \times F4sm$$

$$120\text{-dim } Cl(16) \text{ BiVectors} = 1 \times 28 + 8 \times 8 + 28 \times 1 \text{ of } Cl(8) \times Cl(8)$$

$$128\text{-dim } Cl(16) \text{ Half-Spinors} = 8L \times 8L + 8R \times 8R \text{ of } Cl(8) \times Cl(8)$$

where 8L denotes left-handed Half-Spinors of Cl(8)  
and 8R denotes right-handed Half-Spinors of Cl(8)

and

8Lx8L + 8Rx8R are the Half-Spinors of Cl(16) with consistent handed-ness structure.

**256-dim  $Cl(8) \times 256$ -dim  $Cl(8) = 65,536$ -dim  $Cl(16)$  Clifford Algebra structure is also present in Microtubules = 40 micron size aggregates of 65,536 tubulin dimers that are the basis of Penrose-Hameroff Bohm Potential Quantum Consciousness.**

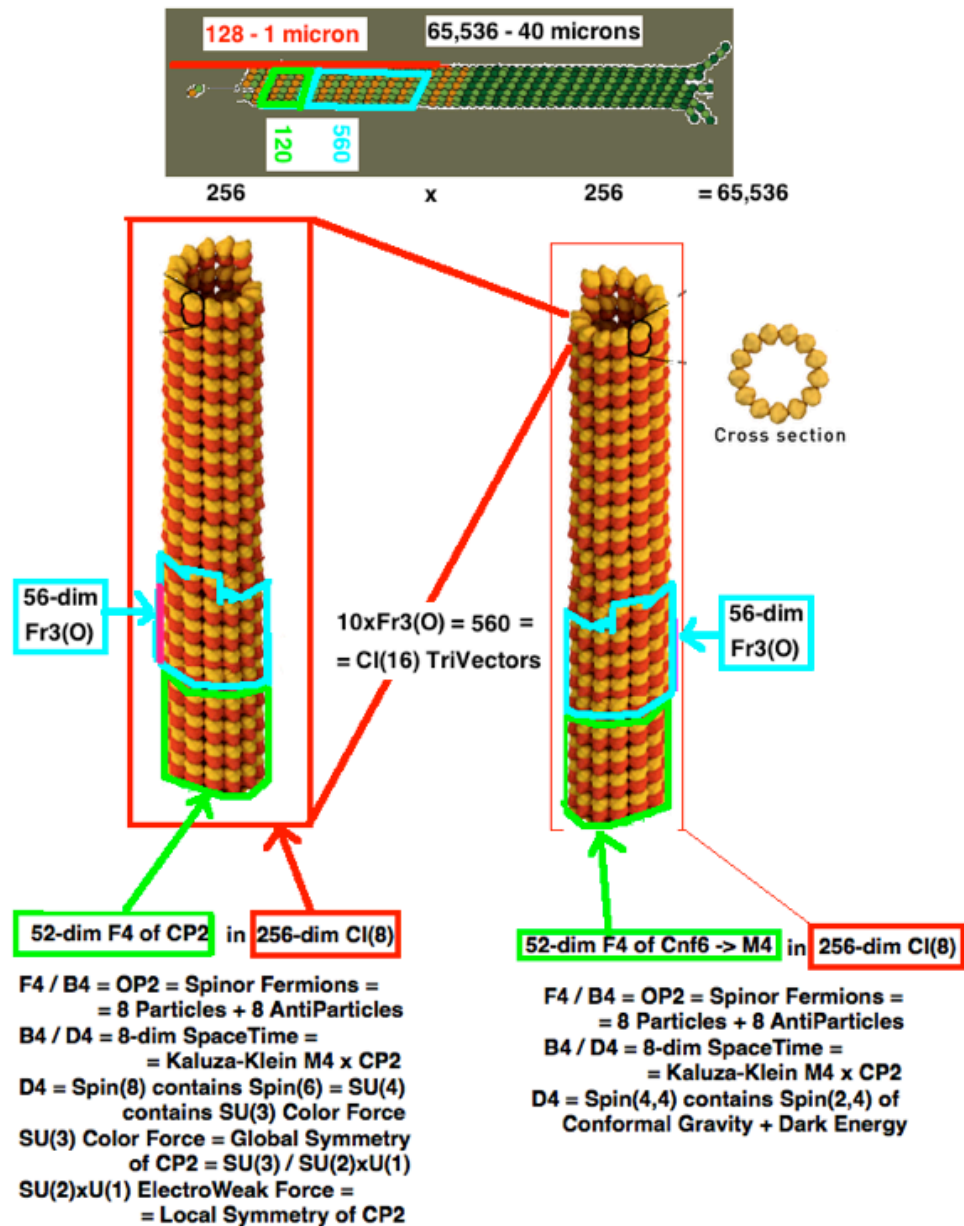

Assembly of 65,536 tubulins into a 40-micron microtubule can be seen to be analogous to the  $256 \times 256$  tensor product  $Cl(8) \times Cl(8)$  where one 256-dim  $Cl(8)$  represents Conformal Gravity+Dark Energy with  $F4gde$  related to the Minkowski  $M4$  of Kaluza-Klein  $M4 \times CP2$  and the other  $Cl(8)$  represents Standard Model  $U(1) \ SU(2) \ SU(3)$  with  $F4sm$  related to the  $CP2 = SU(3) / SU(2) \times U(1)$  of Kaluza-Klein  $M4 \times CP2$

**The E8 and 10 copies of  $Fr3(O)$  of  $Cl(16)$  only use  $248 + 560$  of the 65,536 elements so that 64,728  $Cl(16)$  elements are available for Quantum Consciousness thought processes**

The Great Pyramid slope is of a Golden Ratio Right Triangle representing Conformal Gravity+Dark Energy with Gauge Group Spin(2,4) = SU(2,2)  
 It represents M4 of Kaluza-Klein M4 x CP2 and is represented by F4gde

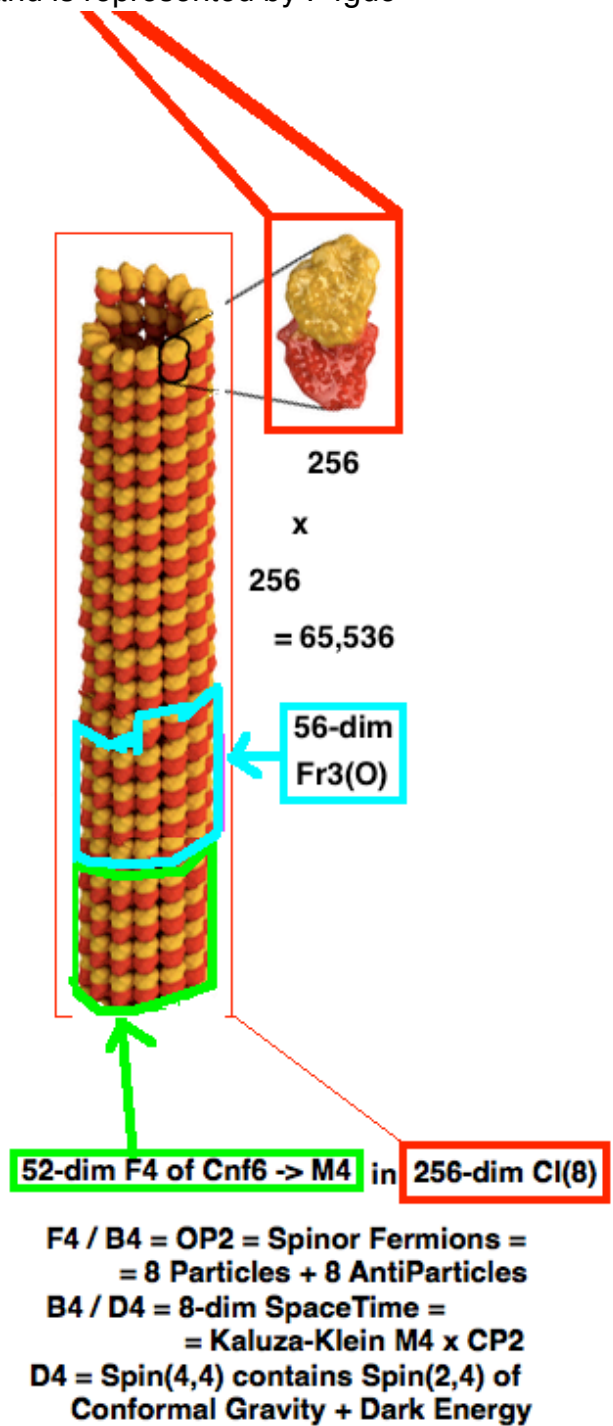
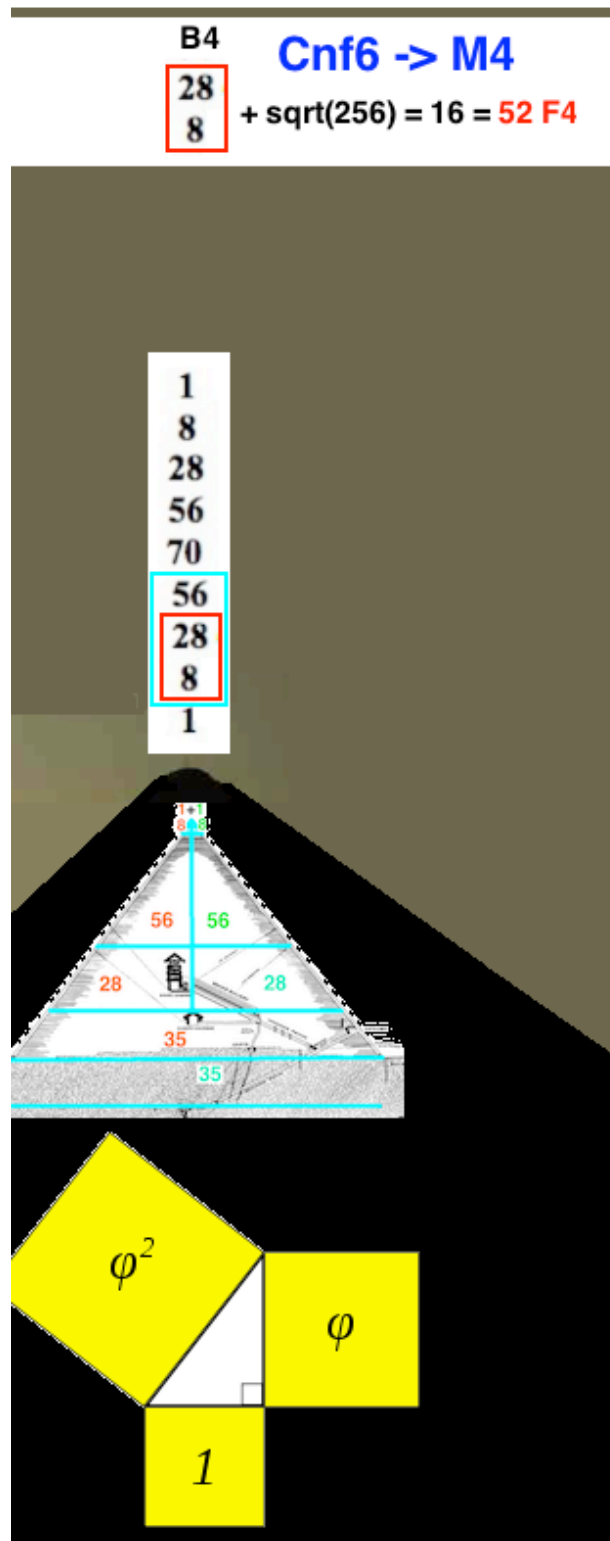



Clifford Algebras were not known to European mathematicians until Clifford in the 19th century and not known to European physicists until Dirac in the 20th century but it seems to me that their structure was known to Africans in ancient times. The courses of the Great Pyramid of Giza correspond to the graded structure of 256-dim  $Cl(8)$ :

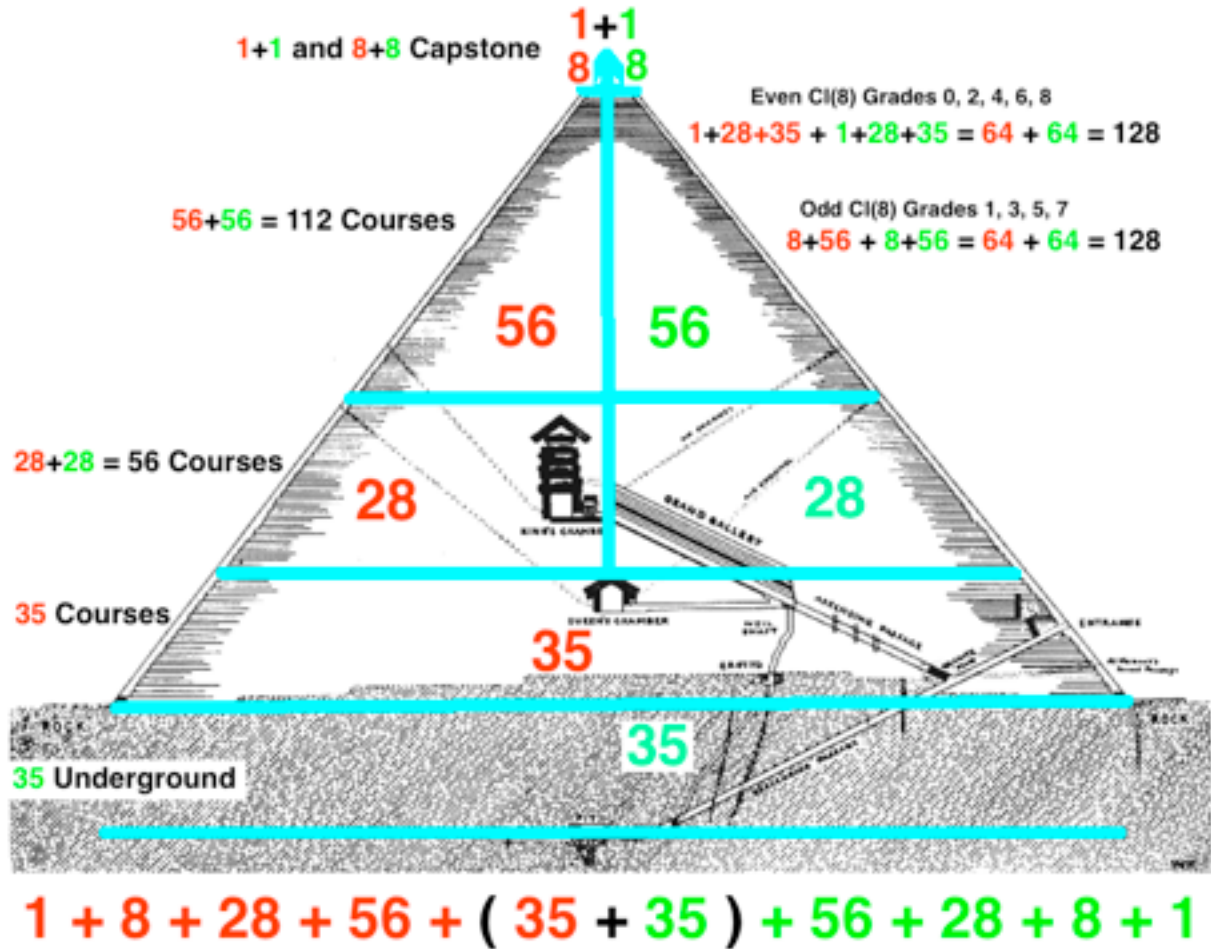

( image adapted from David Davidson image - for larger size see [tony5m17h.net/GreatPyrCl8.png](http://tony5m17h.net/GreatPyrCl8.png) )  
 Above the Grand Gallery is a Great Void leading to Ceiling Chambers above the Upper Chamber - (image from ScanPyramids web site)



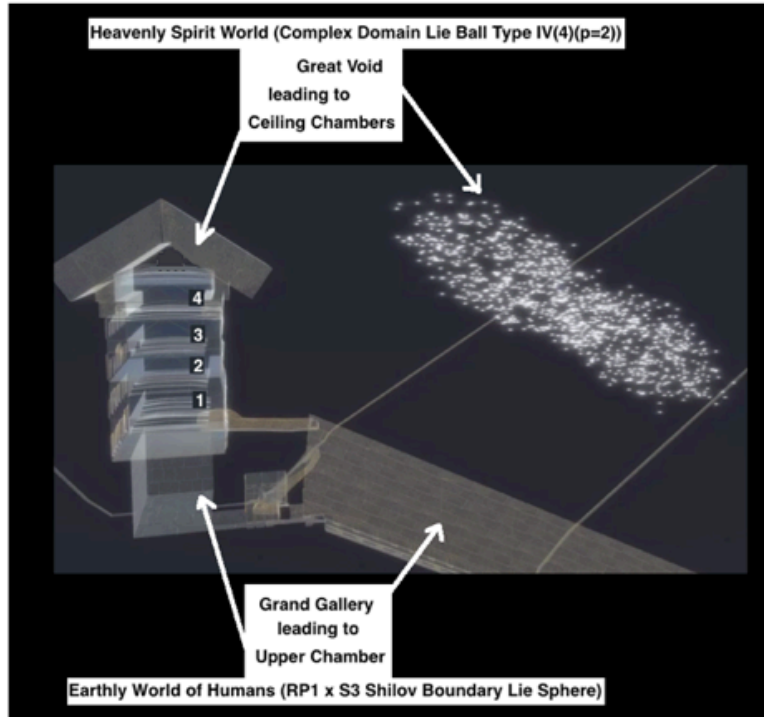

The Builders of the Great Pyramid represented the Real Shilov Boundary Physical world by the Grand Gallery and Upper Chamber that are easily accessible by Humans with Microtubule Quantum Consciousness and they represented the Imaginary Complex World of CI(16) Spacetime Cells mirroring the Human Microtubule World as Ceiling Chamber spaces and the Great Void that are more accessible to Souls of the Spirit World than to Physical Humans.

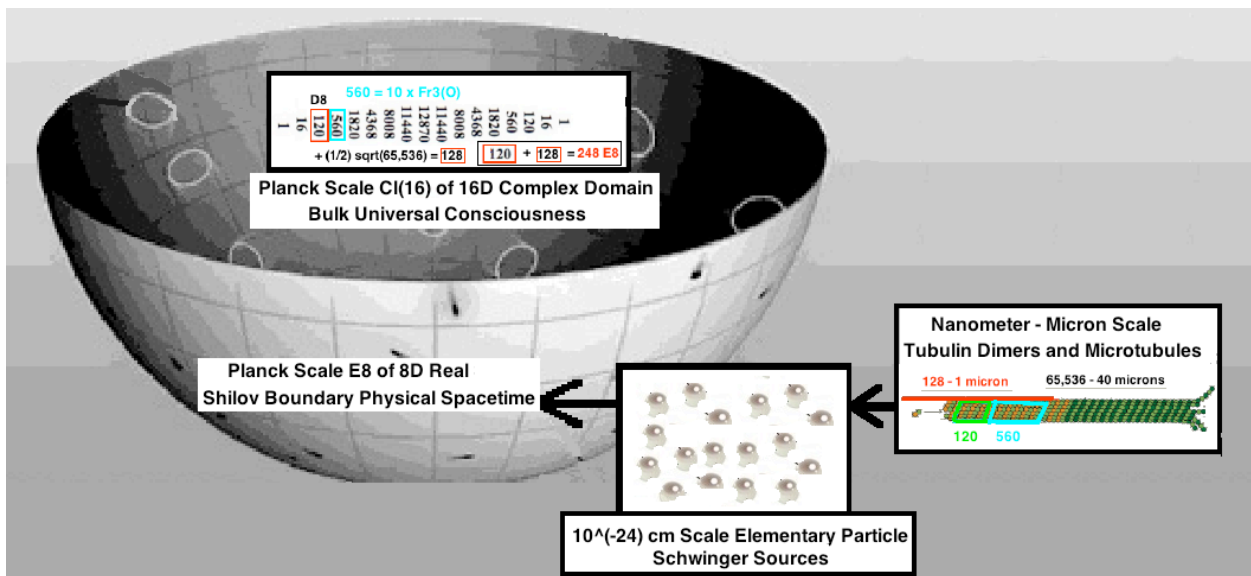

The Second Pyramid slope is of a 3-4-5 Right Triangle representing the Standard Model with Gauge Groups U(1) SU(2) SU(3) It represents CP2 of Kaluza-Klein M4 x CP2 and is represented by F4sm

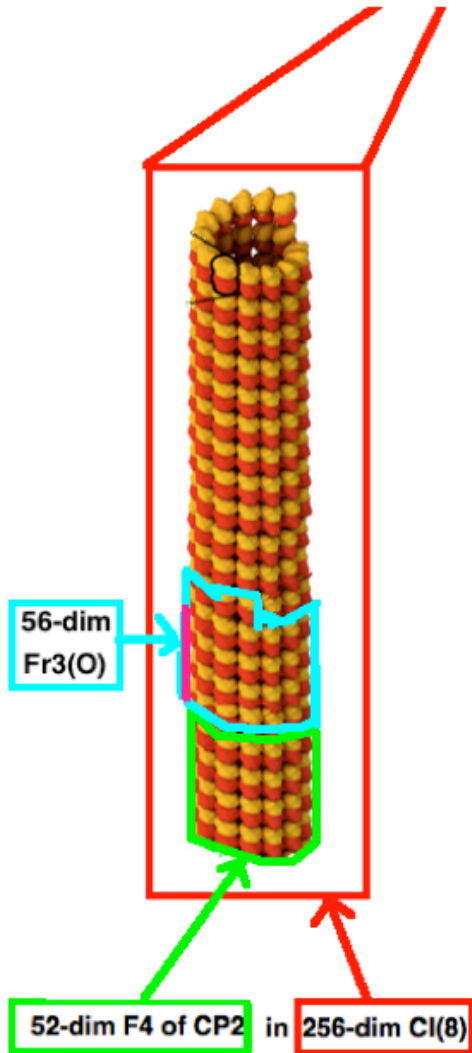

52-dim F4 of CP2 in 256-dim Cl(8)

F4 / B4 = OP2 = Spinor Fermions =  
 = 8 Particles + 8 AntiParticles  
 B4 / D4 = 8-dim SpaceTime =  
 = Kaluza-Klein M4 x CP2  
 D4 = Spin(8) contains Spin(6) = SU(4)  
 contains SU(3) Color Force  
 SU(3) Color Force = Global Symmetry  
 of CP2 = SU(3) / SU(2)xU(1)  
 SU(2)xU(1) ElectroWeak Force =  
 = Local Symmetry of CP2

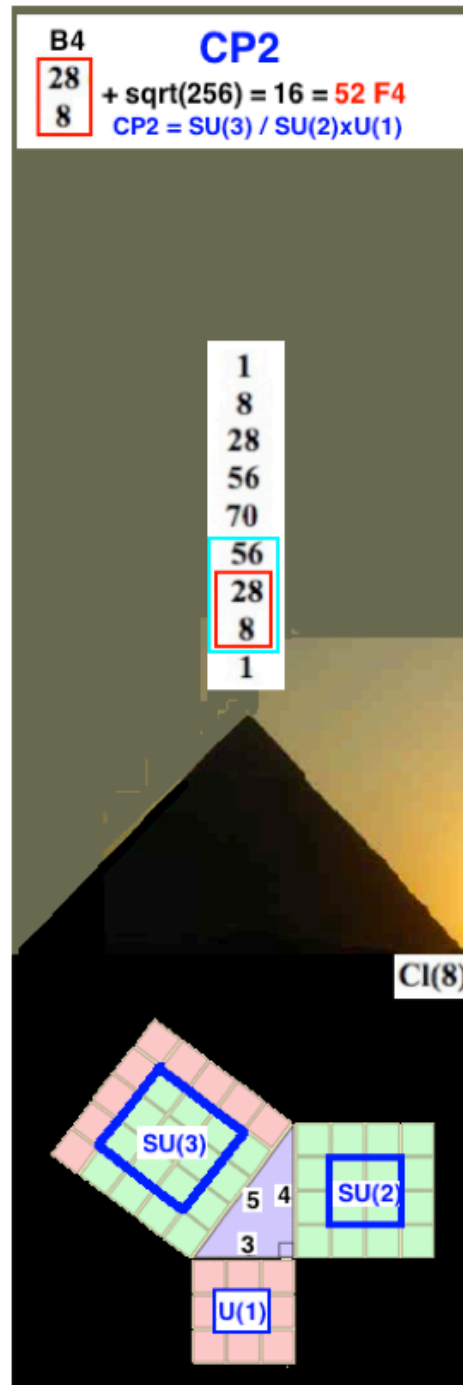

The Sphinx represents 65,536-dim  $Cl(16)$  containing 248-dim  $E_8$   
as the tensor product combination of  
the 256-dim  $Cl(8)$  containing 52-dim  $F_4$ sm related to  $CP^2$  of  $M_4 \times CP^2$   
and the 256-dim  $Cl(8)$  containing 52-dim  $F_4$ gde related to  $M_4$  of  $M_4 \times CP^2$

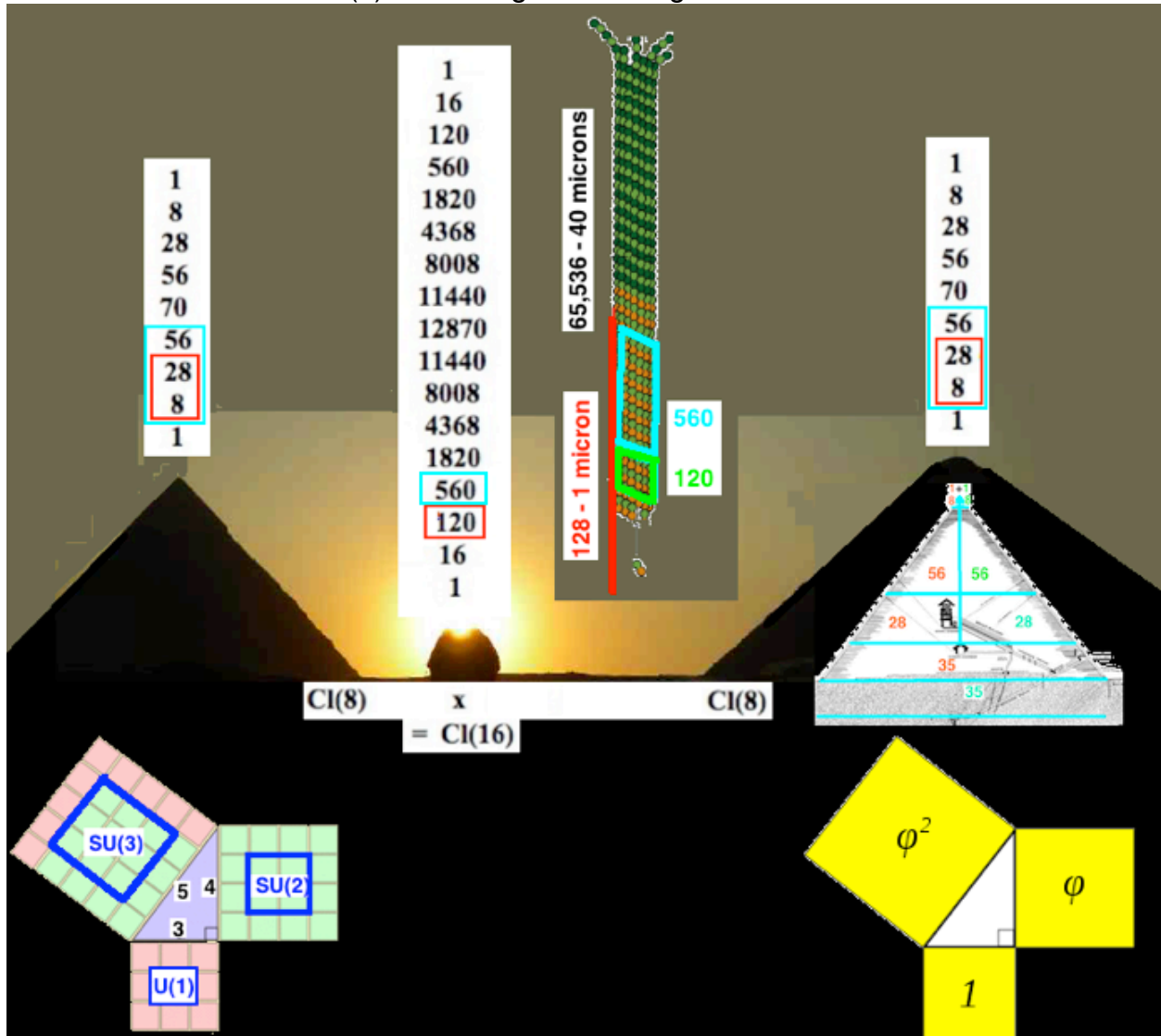

The image on the following page summarizes how the Sphinx represents  
the  $Cl(16)$  combination of the two large  $Cl(8)$  Pyramids  
and also  
the 65,536-element 40 micron Microtubules of Bohm Quantum Consciousness

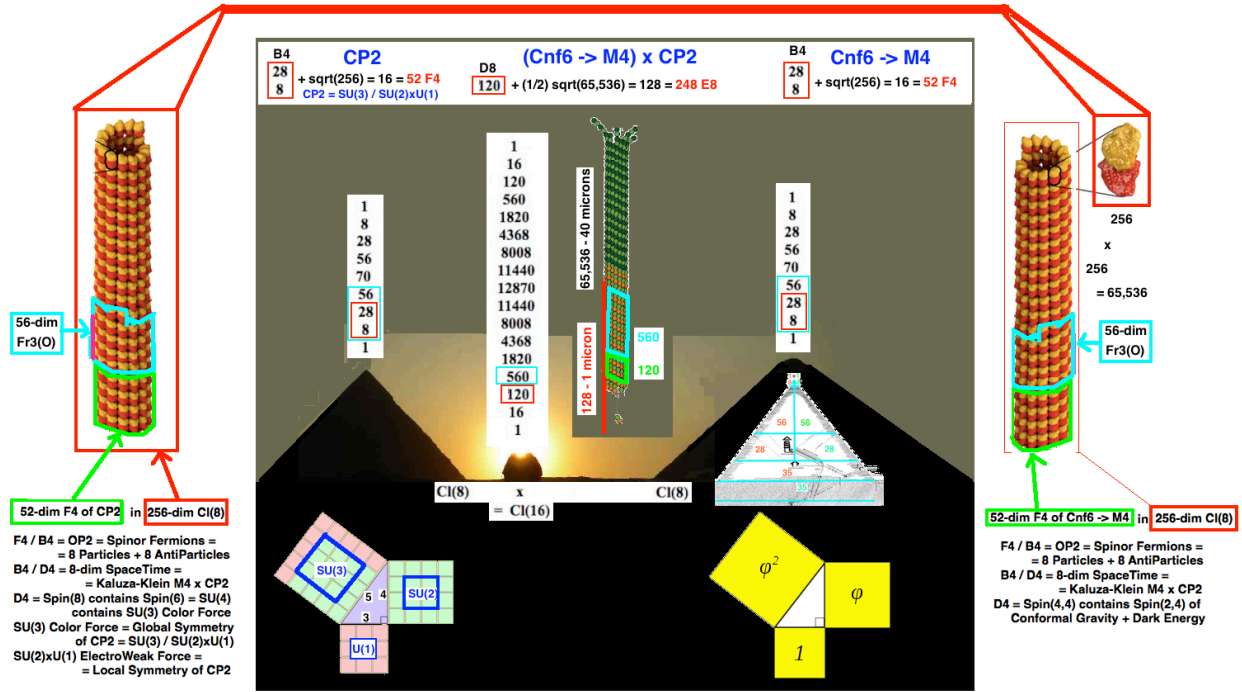

**E8 Kaluza-Klein (Cnf6 -> M4) x CP2**  
 In  $(CI(8) \text{ of } CP2) \times (CI(8) \text{ of } Cnf6 \rightarrow M4) = CI(16)$  containing E8  
 at each of the 256 points of  $CI(8)$  of  $Cnf6 \rightarrow M4$  there are all 256 points of  $CI(8)$  of  $CP2$   
 $D8 = CI(16)$  BiVectors = 120  
**E8 / D8 = 128-dim Fermion Spinor Space = 8 components of 8-8 Fermions**  
 $D8 / D4 \times D4 = A7+1 = 64 = 8\text{-dim position} \times 8\text{-dim momentum}$   
 D4 containing D3 = Spin(2,4) = A3 = SU(2,2) for Conformal Gravity + Dark Energy  
 D4 containing D3 = SU(4) containing Color Force SU(3)  
 $10 \times Fr3(O) = CI(16)$  TriVectors = 560