

## How can the Sagnac effect be explained by both special relativity and classical physics?

Arieh Sher

### **Abstract**

I claim that the Sagnac effect cannot be explained either by special relativity or by classical theory. But, I claim that this effect can be explained by general relativity.

### **General**

First, it is to be noted that Inertial Reference Systems (IRS) that are based on the Sagnac effect are used extensively for navigation in all modern airplanes, ships, satellites, etc. Practically, there is no doubt that the Sagnac effect is valid, as these devices have been experimentally verified to high precision.

On the other hand, from the theoretical aspect of the Sagnac effect, the issue is not clear-cut. The current situation is that both theories, classical and special relativity, explain the results of the Sagnac effect. There is no problem that a physical phenomenon can be explained by two theories, but in this case, there is a profound problem because the two theories are based on two opposing basic assumptions. The Sagnac effect is based on an experiment done by Sagnac in 1913. Sagnac's goal was to address the profound problem of the ether, namely, does the ether exist in the universe? Sagnac was aware of the Michelson-Morley experiment from 1887 that proved that there is no ether and Einstein's special theory of relativity (SRT) from 1905 that is based on the assumption that the ether does not exist. He was convinced that the use of classical physics and his experimental results are in full agreement with the ether theory, and therefore SRT is not valid. In this debate, the people who were proponents of SRT prevailed. The proponents of SRT found ways to explain the Sagnac effect using SRT. Ironically, some people use the Sagnac effect to validate SRT.

The Sagnac effect is a phenomenon observed in rotating systems, particularly in the context of interferometry, where a difference in the travel times of two light beams traveling in opposite directions around closed loop results in an interference pattern.

**SRT explanation:** I claim that solving the Sagnac effect using SRT is not valid, because the ring is rotating, as explained in

[https://www.academia.edu/78702799/Is\\_Special\\_Relativity\\_compatible\\_with\\_General\\_Relativity](https://www.academia.edu/78702799/Is_Special_Relativity_compatible_with_General_Relativity)

**Classical explanation:** Sagnac calculated the time difference ( $\Delta t$ ) between the light that is traveling in both opposite directions:

$$\Delta t = \frac{4 \cdot A \cdot \omega}{c^2}$$

Where:

A.....Area of the ring

$\omega$ .....Forced angular velocity

c....Speed of light

It is difficult to measure the time difference, but it is possible to translate the time difference ( $\Delta t$ ) to phase shift ( $\Delta\phi$ ) which can be measured by the detector.

$$\Delta\phi = \frac{4 \cdot A \cdot \omega}{\lambda \cdot c}$$

where:

$\Delta\phi$ ...Phase shift of the interference fringes

$\lambda$ ....Wave length of light

The following is a picture of an IRS device. The device includes a laser source that sends equal laser beams, one in the CCW direction and the other in the CW direction. The length of the track from the laser source to the detector for both CW and CCW is equal. The IRS does not have any rotating mechanism. It is fixedly attached to the airplane body. Therefore, the absolute change does not depend on the device's rotation on the axis but on the angular velocity  $\omega$  of the airplane.

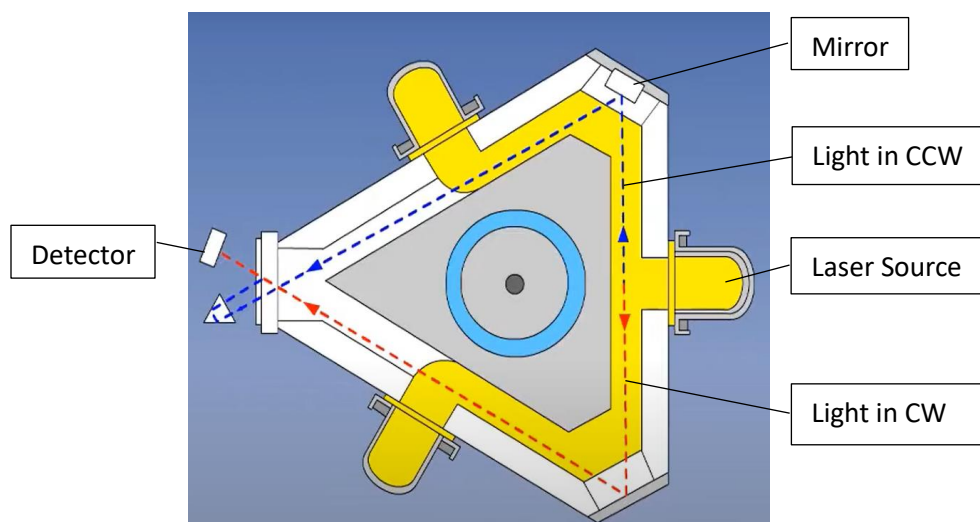

The question is: Is the rotation ( $\omega$ ) in the Sagnac formula essential for the operation of the IRS? First, it is to be noted that people did experiments with linear motion ("Linear Sagnac Effect") and found that the Sagnac delay in a linear motion matches the original rotating Sagnac effect. An additional question: How is the absolute angle of rotation found? It can be argued that the absolute angular position of the airplane results from the integration of small changes in the angular velocity ( $\omega$ ) during the change in the course of the airplane. However, there is a minimum angular velocity that can be detected by the IRS. Say it is  $\sim 0.01$  degrees per second. What happens if the airplane changes its course slowly, say a rate of 0.001 degrees per second? In this case, the IRS will not be able to find its absolute new course.

Thus, the angular velocity ( $\omega$ ) is not essential for the Sagnac effect. I claim that there is an alternative explanation for the Sagnac effect without using the angular velocity ( $\omega$ ).

### Sagnac effect explained by general relativity

The following is an alternative way to explain the Sagnac effect, based on general relativity. According to Einstein, there is a gravitational redshift around any celestial body. This is the phenomenon that electromagnetic waves or photons traveling out of a gravitational well, caused by the celestial body, lose energy. This loss of energy corresponds to a decrease in the wave frequency and an increase in the wavelength, known more generally as a redshift. The opposite effect, in which photons gain energy when traveling into a gravitational well, is known as a gravitational blueshift.

A schematic of the Sagnac interferometer, described above, is shown in the following figure:

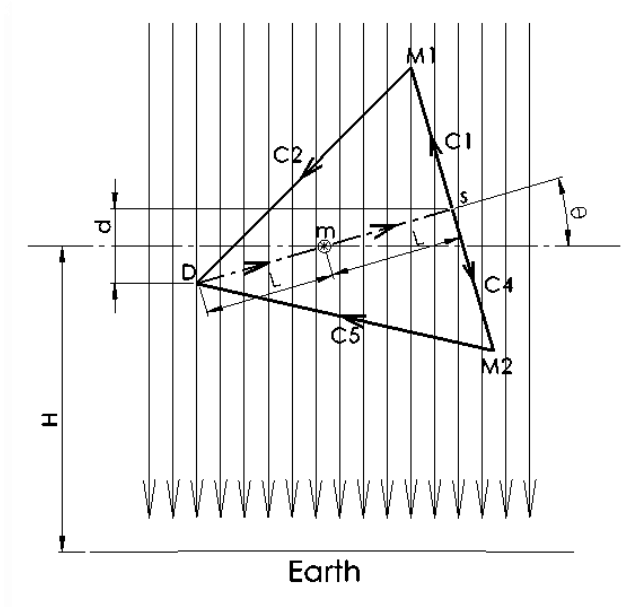

Say an airplane flies in the gravitational field of Earth at height  $H$ .

Earth's gravitational field is represented by the parallel arrows pointing to Earth. (Note at this scale it is assumed that the Earth's surface is flat and therefore the arrows are parallel).

The figure represents a situation where the line connecting  $S$  and  $D$  (Source to Detector) is tilted by an angle  $\theta$  from the horizontal line that is parallel to Earth's surface and passing thru point  $m$ .

Light is leaving  $S$  in two separate trajectories one is  $S$ - $M1$ - $D$  in a counterclockwise (CCW) direction along curves  $C1$  and  $C2$ . The other is  $S$ - $M2$ - $D$  in a clockwise (CW) direction. The two rays unite at the detector at point  $D$ . It is needed to find the work  $U$ , or change in Energy, done by the two rays that move from  $S$  to  $D$ .

In the conservative gravitational field of Earth, the change in energy done by a photon moving along curves S-M1-D and S-M2-D2 is not dependent on the shape of curve but only on the endpoints of the curves S and D :

$$\Delta E = -\int_S^D \vec{F} \cdot \vec{dr}$$

The force in the gravitational field of Earth:

$$\vec{F} = \frac{G \cdot M \cdot m_{\text{photon}}}{(R+H)^2} \cdot \vec{dr}$$

The photon has no mass but it has energy. This energy can be expressed in an equivalent mass:

$$m_{\text{photon}} = \frac{h}{\lambda \cdot c}$$

The vertical distance between S and D

$$d = 2 \cdot L \cdot \sin(\theta)$$

There are two line integrals one is in the CCW and the other is CW directions

$$\Delta E_{\text{CCW}} = -\frac{G \cdot M}{(R+H)^2} \cdot \frac{h}{\lambda \cdot c} \cdot 2 \cdot L \cdot \sin(\theta) = -K \cdot \sin(\theta)$$

$$\Delta E_{\text{CW}} = \frac{G \cdot M}{(R+H)^2} \cdot \frac{h}{\lambda \cdot c} \cdot 2 \cdot L \cdot \sin(\theta) = K \cdot \sin(\theta)$$

Finally at point D:

$$\Delta E = \Delta E_{\text{CCW}} - \Delta E_{\text{CW}} = -K \cdot \sin(\theta) - K \cdot \sin(\theta) = -2 \cdot K \cdot \sin(\theta)$$

Where:

$h$ ..... Planck constant

$\lambda$ .... Wavelength of light

$c$ .... Speed of light

$G$ .....Gravitational constant

$M$ .....Mass of Earth

$m_{\text{photon}}$ .... Equivalent mass of a photon

$R$ .....Radius of Earth

$H$ .....Hight of device above Earth

$\theta$ ....Angle between line S-D and line parallel to Earth surface

$K$ ....Constant

**To sum up:**

- 1) The phase shift between the two beams, measured on the detector, is not due to the change in speed of light, nor in the change of the length of the arms, but rather to the fact that light is forced to move between points that have different potentials in the gravitational field.
- 2) The shape of the Sagnac Interferometer can have any shape between the Source S and the detector D (round, square, triangle, or any arbitrary curve) because all paths between S and D require the same amount of work.
- 3) The measurement of the absolute position of the interferometer is not dependent on the angular velocity that the device rotates on its axis. It is dependent only on the angle  $\theta$ , i.e. the orientation of the Sagnac interferometer in the gravity field.