

Silicon Microstructures and Microactuators for Compact Computer Disk Drives

Denny K. Miu and Yu-Chong Tai

Advances in VLSI and software technology have been the primary engines for the ongoing Information Revolution. But the steady stream of technical innovations in magnetic disk recording technology are also important factors contributing to the economic strengths of the computer and information industry. One important technology trend for the disk drive industry has been that of miniaturization. The storage capacity of the recently announced wristwatch-sized 1.3" diameter disk drives is about eight times that of the shoebox-sized 5-1/4" drives of the early '80s, which themselves are more than twice the capacity of the refrigerator-sized 24" disk drives of the mid-'50s. In terms of storage density, this corresponds to approximately one order of magnitude increase for every decade. As this trend continues (in fact, accelerates), future disk drives will have the same form factor as VLSI's, storing gigabytes of data.

Silicon micromachining technology will play an important role in the fabrication of high-bandwidth servo-controlled microelectromechanical components for future super-compact disk drives. At UCLA and Caltech, for the past two years we have initiated a number of industry-supported joint research projects to develop microstructures and microactuators for future-generation super-compact magnetic recording rigid disk drives, including one to design and fabricate silicon read/write head microsuspensions with integrated electrical and mechanical interconnects, which target the next-generation 30% form factor pico-sliders, and one for electromagnetic piggyback microactuators in super-high-track-density applications, both of which utilize state-of-the-art silicon micromachining fabrication techniques.

Application Background

Data storage devices such as magnetic recording rigid disk drives are key components of today's high-performance computer systems. With the projected significant increase in real-time usage of high-resolution, digitized graphical and video images in desktop computers and smart portable information appliances for future home and office environments, together with the emerging fiber-optic and satellite-linked "information super-highway" international communication infrastructures, it will be of paramount importance to have available a new generation of

Denny K. Miu is assistant professor of mechanical engineering at the University of California, Los Angeles. Yu-Chong Tai is assistant professor of electrical engineering at the California Institute of Technology, Pasadena, CA.

super-compact, super-cost-effective, and super-high-performance recording devices for future massive online computer data storage applications.

Today's digital magnetic recording techniques provide storage at about 400 to 700 megabits of data per square inch of recording surface. This performance is extremely impressive considering that the areal density of the first commercial product was only 2 kilobits per square inch. Magnetic recording has remained and will continue to remain the most viable option when compared to either optical storage or solid-state memory (including Flash) due to its cost-competitiveness (in both component and media levels), overall recording density, access speed and data rate, reliability and non-volatility, and its proven ability to adapt to application-specific needs. More importantly, unlike optical recording, where the recording density is currently being limited by the wavelength of the illumination source, and solid-state memory, where density has always been hampered by advances in photolithographic and thermomechanical packaging techniques, recording density of magnetic recording is currently orders of magnitude away from any physical limits.

Fig. 1 shows the major electromechanical components of the conventional single-actuator/pivot-bearing rigid disk drive design. In computer disk drives, digital information is recorded in concentric tracks on rotating disks using miniaturized read/write (R/W) electromagnetic transducers that are mounted on self-lubricated sub-micron flying slider bearings. These R/W heads are connected to stainless steel suspension arms, which are in turn connected to voice-coil actuators allowing cross-track seek and track-following motions.

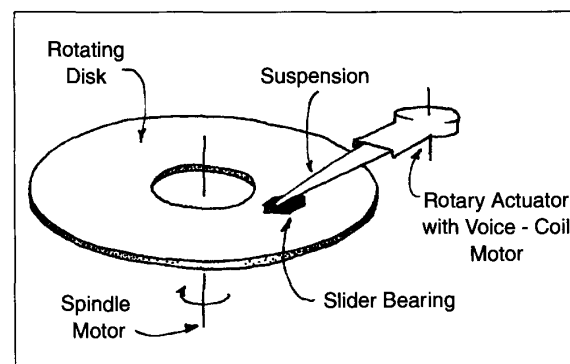

Fig. 1. Major electromechanical components of a conventional high-performance rigid disk drive.

Table 1.
Approximate maximum areal density (measured in megabits per square inch) of some recent commercial products and projections for the next decade.

	MAD	TPI	BPI
1971	1	200	5,000
1981	10	800	12,500
1991	100	2,000	50,000
1995	600	5,000	120,000
2001	10,000	25,000	400,000
2005	100,000	100,000	1,000,000

Whereas bit density (along the track) is much higher than that of optical recording, track density of magnetic recording is typically much lower (although the access speed and data rate are much higher). Unlike optical recording, in magnetic recording, in order to maintain high bit density, the R/W heads must be placed very close to the recording media. On the other hand, in order to minimize latency and maximize data transfer rate, the relative speed between the transducers and the media must be very high. Therefore, tribomechanical and tribochemical wear are important problems inherent in any form of magnetic recording, and in order to maintain proper head/media interface the actuator arm/suspension that serves as the interconnect between the actuator and the sensor must be very compliant in the vertical, pitch, and roll directions. Unfortunately, such mechanical flexibilities tend to limit the bandwidth of the servo systems and therefore the track density. Furthermore, access time is severely limited by residual vibrations caused by the flexibility of the actuator-arm/suspension system, imposing another constraint on track density.

Control Requirements

Table 1 shows the approximate maximum areal density (MAD) of some typical commercial products of recent years, as well as a projection of the required performance for products in the next decade. Note that areal data density is a combination of track density in the radial direction measured in tracks per inch (TPI) and bit density in the tangential direction measured in bits per inch (BPI).

It is interesting to observe that historically BPI is at least an order of magnitude higher than TPI, resulting in a more than 10 to 1 aspect ratio in the lateral dimensions of the unit recording bit cell. It is also interesting to note that for the last two and a half decades, the industry has progressed on a steady 10x/decade (+26% annual compound growth) improvement curve, but since the early '90s, in order to stay competitive, it has accelerated onto a +60% annual growth curve. As a result, by the beginning of the next century, it is projected that the track density will have to be at least 25,000 TPI, which corresponds to a track pitch of 1 μ m and a tracking accuracy of less than 100 nm. Furthermore, in another five years, it is projected that the magnetic recording industry must deliver at least 100,000 TPI, which corresponds to a track pitch of 250 nm and an astonishing servo resolution of 25 nm.

Besides the obvious contributing factors, such as mechanical resonances, spindle runouts, temperature drifts, humidity variations, external shocks/vibrations, bearing hysteresis, cable bias, etc., there are a number of significant sources of off-track errors that are unique to computer disk drives. As opposed to other applications where cost is not a primary concern (aerospace, for example), in disk drives sensors are used only when they are absolutely necessary; otherwise the industry cannot remain competitive. Instead of using position sensors and servo patterns physically encoded on the disk surface, typically in computer disk drives off-track errors are derived using the so-called embedded servo technique, where the necessary off-track information is sandwiched within the magnetic data.

As the disk rotates, the magnetic R/W head will cross specially-coded magnetic servo patterns at regular intervals. After amplification, onboard demodulation electronics will convert the encoded servo data into an off-track position error signal. This signal is then fed into a digital servo controller, which will compensate the error signal by driving the voice-coil actuator. Therefore, any non-linearity and inaccuracy in the servo patterns caused by defects in and inadequacy of the media, head, and electronics will show up as measurable off-track error which cannot be avoided. As bit density and track density increase, this becomes more and more problematic.

In addition, besides track following, the servo system must also move the entire head/suspension assembly across the disk surface as fast as possible. This must be done in such a way to minimize residual vibration. Typically the servo controller will drive the actuator to follow an idealized velocity profile calculated based on a rigid body model. The actuator velocity is not measured, since not only is there not a position sensor, there is also not a velocity sensor. Instead, the velocity is estimated from the embedded off-track error using a reduced-order Kalman-type estimator. Therefore, seek settling of the actuator/suspension system is one of the biggest source of off-track error (both residual vibration of the inherently flexible mechanical structures and the unavoidable velocity estimation error).

Obviously, the higher the servo bandwidth, the easier it is to correct these errors; and the higher the track density, the more important it is to have a high-bandwidth servo system. Currently, track density is less than 5,000 and servo bandwidth is approximately 500 Hz, which is limited by inherent in-the-loop mechanical resonances. For 25,000 TPI, it is projected that the servo bandwidth must be higher than 2 KHz. Furthermore, with spindle speed increased to 7,200 RPM, the required bandwidth will increase to 3 or 4 KHz. It is well recognized throughout the industry that this level of performance simply cannot be done by using or improving upon the existing hardware. The only solution is to use a dual-stage piggyback actuator system similar to that of the optical disk drives. By moving only the R/W head, it is possible to design a high-bandwidth system without requiring an unreasonable amount of power.

Aside from the aforementioned tracking control problems, which mainly have to do with microactuation, there are other major technology issues pertinent to future-generation super-compact disk drives: for example, mechanical packaging, manufacturing, and electromechanical interconnect. To be relevant to disk drive applications, any proposed microactuator design must be consistent with these concerns. In today's disk drive design, many of these problems are solved by compromising and syner-

gizing the designs of the R/W head, the stainless steel suspension, and the voice-coil actuator.

Therefore, from the perspective of a disk drive system, one cannot design the microactuator without worrying about how it will affect the rest of the interconnecting components. Moreover, one cannot design it without thinking about how it will preserve the traditional volumetric cost advantage (dollar-per-megabyte) of magnetic over optical disk drives (i.e., low disk-to-disk spacing, low media cost, and low unit cost of electromechanical components). Finally, one must also project how the proposed design will coincide with the miniaturization trend of the magnetic disk drive industry such that it can lend itself to manufacturing automation and high-shock environments.

Silicon Microstructures

Conventional suspensions are made of stainless steel of uniform thickness with the various features manufactured by a combination of chemical etching, precision stamping, and metal forming operations. As the drive form factor reduces to less than 2" in diameter and the slider bearing shrinks to about 1 by 1 mm in size, the suspension will be less than 1 cm long and the size of its gimbal (which is the structural component that connects the slider to the load-beam of the suspension) will be less than 1.5 mm square. Therefore, it becomes increasingly difficult, if not altogether impossible, to fabricate the suspension/gimbal system using existing material and manufacturing techniques.

Typically, one thinks of silicon as a brittle material and would not normally use it to construct flexible structures. However, brittle material is also elastic, and the only difference is that unlike ductile material, it will not yield; it will simply fracture when the stress reaches the ultimate strength. It is well known that ultimate strength of silicon microstructures is orders of magnitude higher than that in bulk form. Therefore, silicon microsuspension can be made to be flexible but with a very high load-carrying capacity.

Fig. 2 shows our proposed silicon micromachined microgimbal/microsuspension, which has a number of potential operational advantages. First of all, since silicon is a brittle material, silicon suspensions cannot be plastically deformed during manufacturing and handling; quality assurance therefore consists of only visual inspection. In comparison, plastic deformation of stainless steel suspensions (i.e., de-gramming) is the major contributing factor of reduced production yield and in-drive per-

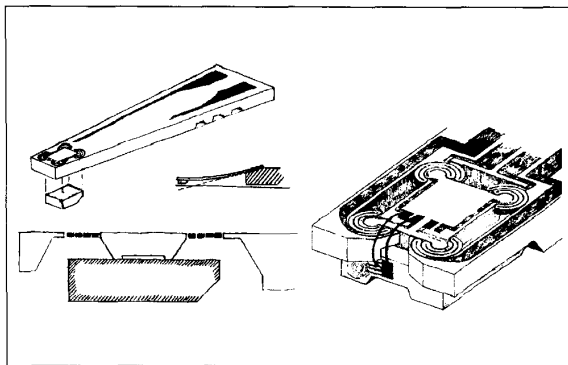

Fig. 2. The proposed design concept of an integrated silicon microgimbal/suspension with built-in electrodes.

formance problems, representing a significant cause of revenue loss.

In addition, due to the difference in process technology, much smaller features can be realized in silicon than in stainless steel (using various anisotropic wet and dry etching techniques), providing much-needed additional degrees of design freedom. For example, in our design, we fabricate very intricate serpentine planar microsuspensions at the four corners of the microgimbal in order to satisfy the conflicting out-of-plane compliance, lateral stiffness, and shock resistance design requirements.

Furthermore, with silicon, it is relatively easy to incorporate electrodes (or even pre-amplifiers) in the suspension arm as well as an electrical coupler in the gimbal area, thereby allowing the possibility of automating not only the mechanical but also the electrical interconnect manufacturing procedures. Currently, in many state-of-the-art products, assembly of the head/gimbal/suspension subsystem represents nearly half of the total manual labor cost.

The design requirements of the silicon microgimbals and microsuspensions are quite challenging. In addition to being soft enough for head/media compliance and stiff enough for tracking (in order to increase servo bandwidth), they must also be strong enough to survive shocks on the order of hundreds of g's. In a way, designing suspensions for the read/write heads is not much different from designing suspensions for our cars; automobile suspensions must be soft enough to give a smooth ride but yet stiff enough to handle fast turns. But most importantly, they must survive shocks with amplitudes well above normal operating conditions.

All suspension springs basically are composed of cantilever beams. The design trick, of course, is to utilize cantilever beams of enough length that for a given tip displacement the operating strains are well below the yield or fracture point of the material. For applications where space is a concern, the obvious solution is to use helical springs, which pack the most material into the smallest area. In the case of the microgimbal, the ideal solution would be to put individual helical springs at the four corners of the slider. Obviously, these soft springs must be designed such that they have sufficient stiffness in the lateral directions, which requires careful optimization of the geometry (aspect ratio, radius, etc.).

Given the form factor that we are designing for, it is nearly impossible to design helical springs out of stainless steel sheet. On the other hand, the advantage of using silicon is that very small features can be achieved. The difficulty, however, is not so much in fabricating a planar helical spring but in fabricating the interconnect between the center of the spring and the slider (or the substrate). Fig. 3 shows the individual planar microsuspensions at the four corners of the microgimbals. These springs are a variation of the conventional helical springs. Instead of spiral beams (which will require interconnects), they are composed of alternating curved beams. Much work has been performed in optimizing the various beam widths and the stress relief holes around the turns.

The fabrication process for the silicon microgimbal/microsuspension is rather simple and consists of only two major steps: reactive-ion etching (RIE) using SF_6 plasma to define the microspring on the front surface of the wafer and anisotropic chemical etching on the back to create a trapezoidal cavity which would allow the attachment of the read/write slider directly under

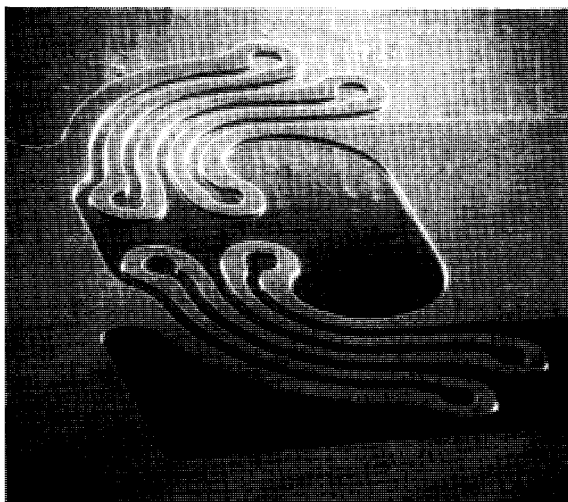

Fig. 3. SEM micrograph of a five-turn silicon microgimbal.

the center coupon. For etch stop, we use epi-wafers which consist of a 20 to 30 μm thick lightly-doped epitaxial layer on top of a 4 μm heavily boron-doped buried layer.

Fig. 4 shows a summary of the complete processing steps which require only three masks. The silicon wafer is first thermally oxidized at 1050° C to form a 3,000 Å thick silicon oxide layer on the top and bottom surfaces, which serves as the protection coating for subsequent chemical etching as well as insulation for the electrical interconnect. 200 Å thick titanium and 1,000 Å copper are then electron-beam evaporated on the top surface. Photoresist is then spun and patterned using the first mask to form the electroplating mold for the electrodes. After electroplating, the seed layer is then patterned using the second mask to define the microsprints. 2,000 Å thick permalloy is then electroplated to protect the copper. The third mask is finally used to pattern the silicon oxide on the back surface for the cavities.

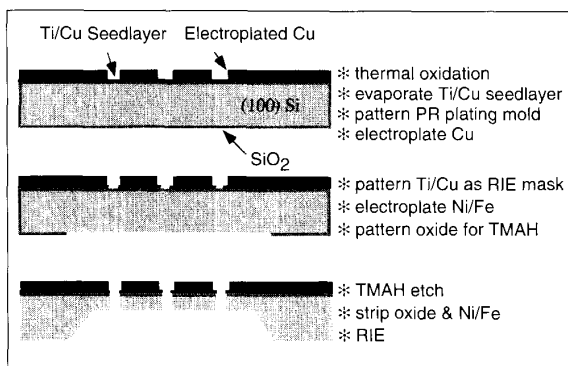

Fig. 4. Processing steps for the silicon serpentine microgimbal.

After the final photolithographic step, the wafer is ready for anisotropic etching using tetramethyl ammonium hydroxide (TMAH). Since the copper seed layer is protected by permalloy,

it will not be attacked by TMAH. After TMAH back-etch and removal of silicon oxide, we perform RIE until the microgimbals are completely freestanding. This is then followed by chemical removal of the permalloy, once again revealing the copper electrodes. The very last step is to dice and individualize the micro-suspensions.

Silicon Microactuators

Our next objective is to design and fabricate a piggyback microactuator which can be packaged to move the slider relative to the suspension such as to completely eliminate any in-the-loop structural resonances. This device must be very low-profile so that it is consistent with the disk-to-disk spacing requirement of future products. In addition, it must be mass-manufacturable and be able to operate in low-voltage, low-power environment. Furthermore, electrical interference must be at an absolute minimum in order not to degrade the read/write operations.

Fig. 5 shows a design concept which uses the aforementioned silicon microgimbal as the structural platform. Instead of a solid coupon in the center, the read/write slider is now attached to the microgimbal by a set of hairpin-like planar springs, which are designed to have maximum in-plane compliance while maintaining adequate out-of-plane, pitch and roll stiffnesses.

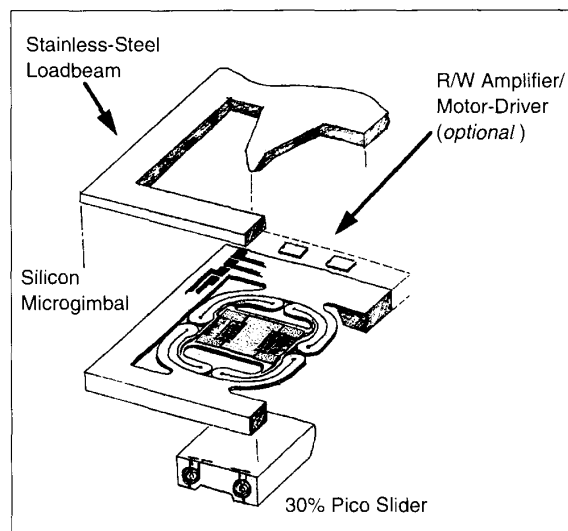

Fig. 5. Design concept for a silicon micromachined electromagnetic piggyback planar microactuator for high TPI applications.

A pair of thin-film variable-reluctance microactuators are used to move the slider/recording head in the in-plane direction, each of which is consisted of two pieces. The stationary piece is mounted on the outside frame and is constructed of one layer of permalloy with a wrapped-around helical flat copper coil. The moving piece is attached to the slider, and when a voltage is applied to the coil magnetic force will be exerted on the moving core, pulling it toward the stator and resulting in in-plane/cross-track micron-level fine motion of the read/write slider. This design has the important advantage that the required fabrication technology is very similar to that of thin-film heads, leveraging the expertise of the magnetic recording industry. Fig. 6 summa-

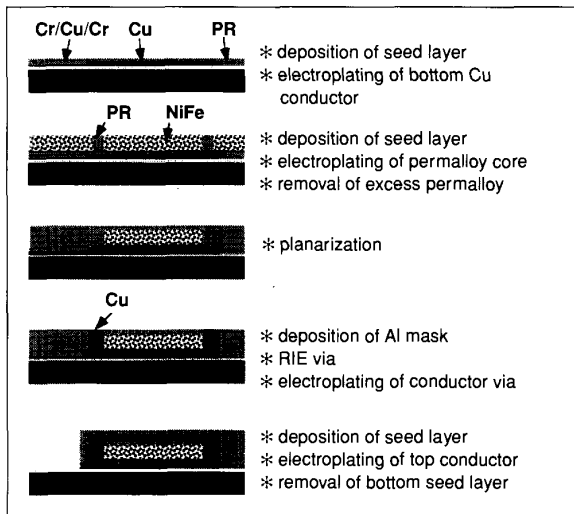

Fig. 6. Process steps for the silicon electromagnetic microactuator.

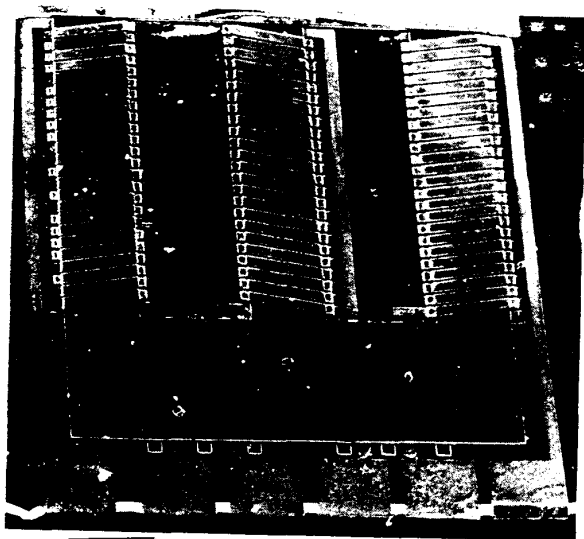

Fig. 7. Micrograph of a fabricated coil-structure for the proposed electromagnetic microactuator.

Fig. 7 shows some typical fabrication results.

Integrated Drive Design

The paths of product development for magnetic disk drives are littered with thousands of technically great ideas whose only sins are being ahead of their time. With hindsight, it is clear that if one wishes the magnetic storage industry (or any industry, for that matter) to accept and to embrace any proposed changes in design paradigm, one must not only solve the fundamental technical problems but must also provide a gradual and logical path such that the industry can proceed one technology step at a time. That is, as an industry, it will never allow itself to fly a new

engine with an entirely new airframe. For that reason, we focus our immediate efforts on a number of strategically important near-term research projects to fabricate silicon microstructures and microactuators using the proposed micromachining technology. Our self-imposed constraint is that each of these proposed silicon devices must be a one-to-one replacement to its conventional equivalent, requiring no (or at least minimal) changes in the drive design.

At the same time, we envision and position these silicon devices to be the enabling precursor technology necessary to achieve a truly integrated design of the future. Fig. 8 illustrates our futuristic product concept for the high-performance super-compact VLSI-level data storage array. At a recording density of 100 gigabits per square inch, the recording capacity for each of the 2-centimeter diameter, 0.5-centimeter high module is approximately 20 gigabytes of digital data. At that form factor, they are compatible with surface-mounting technology, and as an array will significantly increase the online storage capacity, access speed, data rate, redundancy, and reliability of future products.

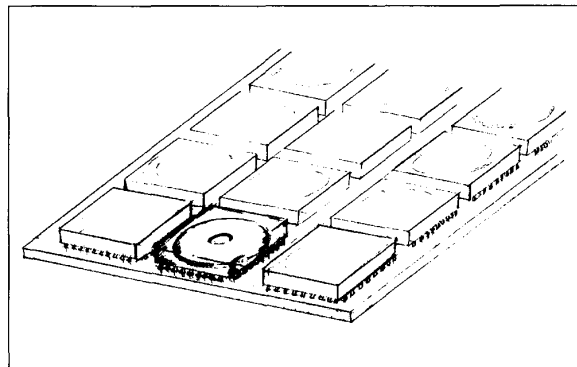

Fig. 8. SCALED Technology: Super Compact Array of Low-cost Enormous-capacity Disk drives.

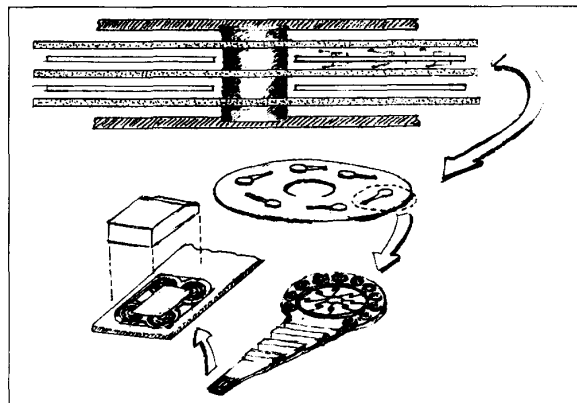

Fig. 9. Array of articulated torsional bearings with integrated electromagnetic microactuators.

Fig. 9 shows the proposed silicon micromachined microelectromechanical actuator array that would allow such integrated design paradigm to take place. Our vision is that disk drives of the future shall consist of only two major components—a stack

of rotating disks, which contain the recording media, and a stack of stationary silicon disks sandwiched between the recording disks, which consist of arrays of high-resolution, high-bandwidth microactuator/suspension/read-write heads to accomplish the required positioning and recording operations. These integrated microdevices will perform all of the sensing, actuation, signal processing, and control functions in a single low-cost, mass-manufacturable, silicon-based package, thereby eliminating much of the costly and complicated external electrical and electromechanical interconnections that exist in the conventional disk drive design.

Perhaps one day we shall think of such silicon micromachined integrated disk drives (IDs) the same way we think of integrated circuits (ICs) today, a logical and rather obvious technology evolution consistent with miniaturization and performance improvement.

Summary

Silicon micromachining techniques offer many exciting opportunities for fabricating both passive microstructures and active electromagnetic microactuators for significant form factor reduction and increase in recording density of future magnetic recording rigid disk drives. In this overview paper, we have presented some recent results and novel product concepts. In other related papers, we have documented detailed results related to design optimization, process refinement, and static/dynamic testing.

Acknowledgments

The work presented here was conducted at the Caltech Micromachining Laboratory with support from the University of California MICRO program and matching funds from the Applied Magnetics, Hewlett-Packard, IBM, Magnacomp, Maxtor, Quantum, Read-Rite, and Seagate Technology corporations, and the National Storage Industry Consortium (NSIC). The results are the combined efforts of our many colleagues, Amish Desai, Wen Hsieh, Raanan Miller, Weilong Tang, Viktoria Temesvary, and Shuyun Wu.

References

[1] D.K. Miu and Y.-C. Tai, "Silicon Micromachined SCALED Technology," *Proc. of the 1993 JSME International Conference on Advanced Mechatronics*, Tokyo, Japan, August 2-4, 1993, pp. 527-532.

[2] D.K. Miu, S. Wu, S. Tatic-Lucic, and Y.-C. Tai, "Silicon Micromachined Microstructures for Super-Compact Magnetic Recording Rigid Disk Drives," *Proc. of the 7th International Conference on Solid-State Sensors and Actuators*, Yokohama, Japan, June 7-10, 1993, pp. 771-773.

[3] D.K. Miu, S. Wu, V. Temesvary, and Y.-C. Tai, "Silicon Microgimbals for Super-Compact Magnetic Recording Rigid Disk Drives," *ASME Advances in Information Storage Systems*, vol. 5, pp. 149-152, 1993.

[4] V. Temesvary, S. Wu, W. Hsieh, Y.-C. Tai, and D.K. Miu, "Design, Fabrication and Testing of Silicon Microgimbals for Super-Compact Rigid Disk Drives," being reviewed for publication in the *IEEE/ASME Journal of MEMS*, 1994.

[5] S. Wu, Y.-C. Tai, D.K. Miu, V. Temesvary, and W. Hsieh, "Silicon Micromachined Integrated Suspension Systems for 30% Read/Write Pico-Sliders," in preparation, to be submitted to the *ASME Journal of Vibration and Acoustics*.



Denny K. Miu has been with the Mechanical Engineering Department at UCLA since 1987 and has been working with the computer rigid disk drive industry since 1983. His previous work includes head/disk dynamics, suspension design, and residual vibrationless tracking accessing control. For the last two years, he has been working with Yu-Chong Tai on silicon micromachining and its application to computer disk drives. Miu is a recipient of the NSF Presidential Young Investigator Award and is also the founding co-chairman of the ASME Subdivision on Information Storage and Processing Systems. He has published over twenty-five journal papers on mechanics and control issues related to computer disk drives as well as a graduate-level textbook with Springer-Verlag on advanced mechatronic problems of controlled electromechanical systems.



Yu-Chong Tai received his B.S. degree in electrical engineering from the National Taiwan University in 1981, and the M.S. and Ph.D. degrees from the University of California, Berkeley, in 1986 and 1989, respectively. After completing his education, he joined the faculty of electrical engineering at the California Institute of Technology, where he is currently an assistant professor. His research interests have included silicon micromachining and its applications, such as neural prosthetic devices, integrated millimeter-wave waveguides, micro fluidic devices, miniature hard-disk drives, microphones, silicon hot-wire anemometers, magnetic milli and micro actuators, shock sensors, and MEMS systems for active fluid control. Tai received the Presidential Young Investigator Award and the David and Lucile Packard Fellowship in 1991. He is a member of the editorial boards for the *Journal of Micromechanics and Microengineering*.