

# ROBUST VIDEO TRANSMISSION OVER MIMO-OFDM SYSTEM USING MDC AND SPACE TIME CODES

*Haifeng Zheng<sup>a</sup>, Congchong Ru<sup>b</sup>, LunYu<sup>a</sup>, Chang Wen Chen<sup>c</sup>*

<sup>a</sup>College of Information Technology, Fuzhou University, Fuzhou, Fujian, China, 350002

<sup>b</sup>Department of Electronic Engineering, Tsinghua University, Beijing, China, 100084

<sup>c</sup>Dept. Electrical & Computer Eng., Florida Institute of Technology, Melbourne, FL 32940 USA

## ABSTRACT

MIMO-OFDM is a promising technique for the broadband wireless communication system. In this paper, we propose a novel scheme that integrates multiple description coding (MDC), error resilient video coding, and unequal error protection strategy with various space time coding codes for robust video transmission over MIMO-OFDM system. The proposed MDC coder generates multiple bitstreams of equal importance which are very suitable for multiple antennas system. Furthermore, according to the contribution to the reconstructed video quality, we apply unequal error protection strategy using BLAST and STBC space time codes for each video bitstream. Experimental results have demonstrated that the proposed scheme can achieve desired trade-off between the reconstructed video quality and the transmission efficiency.

## 1. INTRODUCTION

Video communication over wireless network has been a significant challenge for current multimedia technology. As is well known, wireless channels often suffer from multipath fading, shadowing, inter-symbol interference, and etc. Meanwhile, compressed video is very sensitive to error-prone environment. Any transmission error may lead to the loss of decoding synchronization and severe degradation to the received video quality.

Fortunately, great progresses have been made in the recent development of wireless communication and video transmission. Orthogonal frequency division multiplexing (OFDM) has become a promising technique for transmission of signals applied in the broadband wireless communication systems. Moreover, multiple antennas system with multiple transmitters and multiple receivers, called a multiple-input and multiple-output (MIMO) system, has been shown to be an effective way to transmit high data rates over wireless channels. Therefore, OFDM combined with multiple-input and multiple-output system (MIMO-OFDM) is not only able to increase the diversity gain and enhance the capacity of the system but also able to combat the channel fading and interference effectively.

On the other hand, multiple description coding has been proposed to improve the robustness of image and video

transmission over error-prone network such as Internet and wireless network. MDC generates multiple descriptions (bitstreams) of equal importance from the same source signal with the premise that not all the descriptions would experience the losses simultaneously. As a result, this loss resilient source coding strategy is very suitable for wireless packet network and multiple antennas system, because the probability of all channels falling into deep fading simultaneously is small. There have been several research work to report video transmission over multiple antennas system [1][2][3][4][5]. However, none of these existing schemes has explored the integration of multiple data bitstreams with MIMO-OFDM.

In this paper, we construct a new system that integrates multiple description coding, error resilient video coding, unequal error protection scheme using space time coding for robust video transmission over MIMO-OFDM system. First, video sequence is encoded based on overcomplete motion compensated temporal filtering, and then using multiple description coding scheme to generate four equally important bitstreams. After channel coding with LDPC, the bitstreams are transmitted in two modes according to their contribution to the decoding reconstruction. Important information bits, such as the motion vectors and GOP header, are transmitted in space time block coded (STBC) mode to achieve better error protection, while the other less important bits are transmitted in BLAST mode to gain higher transmission efficiency.

The rest of the paper is organized as follows. The proposed transmission scheme is described in Section 2. Then, simulation results are presented in Section 3 to demonstrate the effectiveness of the proposed scheme. Finally, we conclude in Section 4 with some discussion.

## 2. THE PROPOSED TRANSMISSION SCHEME

### 2.1 Multiple description and error resilient video coding

In this research, video coding is based on overcomplete motion compensated temporal filtering. Unlike the conventional hybrid standardized video coding scheme, motion estimation and motion compensation in the MCTF-

based video coding architecture is performed in an open loop structure. Error propagation may occur only across the temporal levels through the reconstructed L frames. This characteristic also improves the performance of error resilience for the scheme.

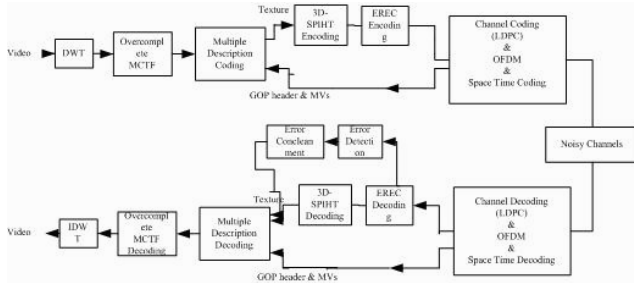

Fig 1: The overall block diagram of the proposed system.

As mentioned before, after the video coding, four equally-important bitstreams is generated using multiple description coding. The MDC scheme adopted in this paper is similar to that of our previous work [6], which is based on the wavelet-domain partitioning strategy. After the overcomplete motion compensated and temporal filtering, the generated texture information in the lowest frequency subband in the lowest frequency frame is divided into four parts, as shown in Figure 2. And the other wavelet coefficients within a GOP are distributed into different descriptions according to 3D-EZW tree structure [7]. Then, we further adopt a method developed by Creusere [8] for partitioning the wavelet coefficients into group to form each 3D-EZW zero-tree and independently encoding and decoding with 3D-SPIHT algorithm [9]. The main advantage of this method is to enhance the performance of error resilience and to facilitate error concealment to be performed for the lost information. For example, when the wavelet coefficients in one wavelet tree are corrupted, we can employ appropriate interpolation algorithm to recover them using the neighboring coefficients from the other bitstreams. In this case, in order to have the basic information for reconstructing the coarse video quality for each description, the motion vectors information is contained in each description.

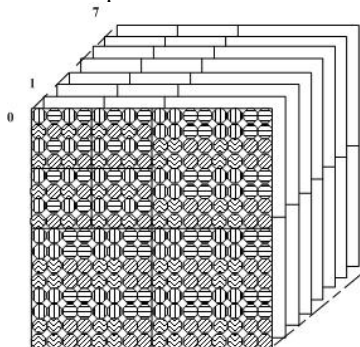

Fig. 2: An example of partitioning strategy.

Meanwhile, in order to guarantee balanced reconstructed video quality for each zero-tree, we encode each zero-tree using variable-length bitstreams to a certain bitplane. Consequently, the coded bitstream is sensitive to bit errors. A single bit error may lead to loss of synchronization between encoder and decoder. Therefore, we apply EREC [10] to reorganize variable-length bitstreams coded by 3D-SPIHT algorithm into fixed-length data slots. Furthermore, in the EREC encoding stage, we add one bit for parity check for each bitplane in the first three bitplanes for the purpose of error detection. Since each antenna assumes that not all bitstreams experience deep fading simultaneously, we can assume that adjacent slots would not be corrupted at the same time. Therefore, if we detect the errors occurring in one slot in some description, we can carry out error concealment. And error concealment for the corrupted wavelet coefficients is carried out only in the lowest frequency subband in the lowest frequency frame. The overall block diagram of the source coding scheme is shown in Figure 1.

## 2.2 Unequal error protection using BLAST and STBC

In this paper, we consider a MIMO-OFDM system with  $M_t$  ( $M_t=4$ ) transmit and  $M_r$  ( $M_r=4$ ) receiver antennas for robust video transmission. Each antenna employs an OFDM modulator with  $N$  subcarriers. Transmitting signals of different subcarriers will be transmitted simultaneously over all transmit antennas. As mentioned before, the coded source bits transmitted over each antenna also contain unequally important information according to their contribution to the decoding process. Motivated by this, we propose an unbalanced transmission scheme for multiple bitstreams generated by multiple description coding scheme as discussed in the previous section. In this research, we combine BLAST and STBC in this multiple antennas system to obtain unequal error protection for robust video transmission. The illustration of the proposed UEP scheme is shown in Figure 3.

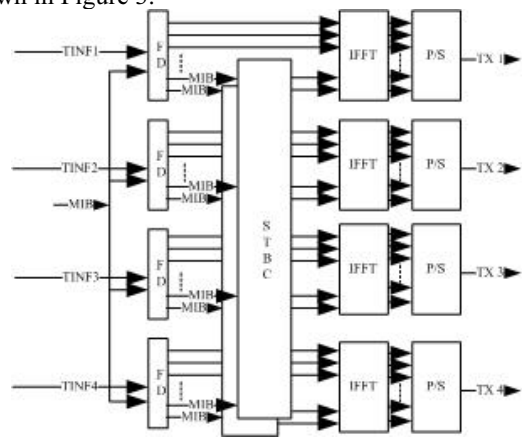

Fig 3: The block diagram of the proposed UEP scheme.

As we have discussed, the coded source bits might be divided into two parts according to their contribution to the decoding process, namely the TINF, which stands for the texture information, and MIB, which presents the more important bits including motion vectors and GOP header. Considering the independent channels generated by BLAST, it is intuitively suitable for the transmission of TINF bits. Additionally, the transmission efficiency will also be increased greatly. However, MIB is crucial component in a video codec. For example, even one bit error in the MIB bits may cause a decoding collapse or cause serious error propagation within a GOP and greatly degraded video quality. Comparing with BLAST, STBC achieves full diversity gain. It performs much better than the BLAST in terms of BER, however, with much lower transmission efficiency. Consequently, to guarantee trade-off between reconstructed video quality and transmission efficiency, we apply different space time coding methods in the scheme, as shown in Fig 3. In this scheme, we employ four transmit antennas to match the four MDC bitstreams from the video encoder. Assuming the space time code rate is  $R$ , MIB has  $B_{MIB}$  bits and TINF has  $B_{TINF}$  bits, we will have  $P = \lfloor B_{MIB}N / (B_{TINF}R + B_{MIB}) \rfloor$  subcarriers to transmit MIB. These subcarriers are denoted as  $\{f_1 \ f_2 \ \dots \ f_P\}$ .

#### A. BLAST

V-BLAST structure is employed in this scheme. At the transmitter, each MDC stream is assigned to one antenna which holds an independent transmit channel as mentioned before. At the receiver, the frequency domain signals at subcarrier  $\{f_{P+1} \ f_{P+2} \ \dots \ f_N\}$  will be sent to a simple ZF detector [11] to recover the transmit symbols. Notice that optimal detect algorithms might bring better performance, but the process complexity and delay would be increased together. An efficient way to solve this problem is to import channel codes. In this scheme, the LDPC code is employed [12]. As a result, the transmission performance is greatly increased.

#### B. STBC

For four transmit antenna system, assuming that the channel is stable during four OFDM symbol periods, we construct a 3/4 rate STBC code with amicable designs [13]. It is obvious that three complex symbols per subcarrier are transmitted during four OFDM symbol periods. At the receiver, in order to obtain an orthogonal channel matrix, we define the received signal at the  $j$  th receiving antenna,

$n$  th subcarrier as

$$Y_j(n) = [y_j^1(n) \ y_j^2(n) \ y_j^3(n) \ y_j^4(n) \\ (y_j^1(n))^* \ (y_j^2(n))^* \ (y_j^3(n))^* \ (y_j^4(n))^*]$$

Here  $(\bullet)^*$  denotes conjugate operation and  $y_j^t(n)$  presents the received signal at the  $t$  th OFDM symbol period. Then the transmit symbol can be recovered as

$$\hat{c}(n) = \frac{1}{M_r * \sum_{i=1}^{M_r} \|h_{i,j}\|^2} \sum_{j=1}^{M_r} H_j^H(n) * Y_j(n)$$

Where  $\hat{c}(n) = [\hat{c}_1^*(n) \ \hat{c}_2^*(n) \ \hat{c}_3^*(n) \ \hat{c}_1(n) \ \hat{c}_2(n) \ \hat{c}_3(n)]^T$ ,

and  $H_j(n)$  is the orthogonal channel matrix at subcarrier  $n$  receive antenna  $j$  and  $(\bullet)^H$  denotes the conjugate transpose operation. Finally, the video coded bit sequence will be ready for decoding after constellation de-mapping and bits rearrangement.

### 2.3 Channel Model

We consider a frequency selective Rayleigh fading channel which has  $L$  independent delay path with arbitrary delay power profiles. The baseband equivalent channel can be modeled as

$$h_{i,j}^k = \sum_{l=0}^{L-1} \alpha_{i,j}^k(l) \sigma(t - \tau_l) \quad (1)$$

Where  $\alpha_{i,j}^k(l)$  is the path gain coefficient of the  $l$  th path between transmit antenna  $i$  and receiver antenna  $j$  at the  $k$  th OFDM symbol period, and  $\tau_l$  presents the  $l$  th path delay. The  $\alpha_{i,j}^k(l)$  is modeled as zero-mean complex Gaussian random variable with variance  $E|\alpha_{i,j}^k(l)|^2 = \sigma_l^2$ . The channel coefficients are assumed spatially uncorrelated.

The received signal at  $n$  th subcarrier at  $j$  th receive antenna during  $k$  th OFDM block may be denoted as

$$y_j^k(n) = \sqrt{\rho} \sum_{i=1}^{M_t} x_i^k(n) H_{i,j}^k(n) + \omega_j^k(n) \quad (2)$$

where  $\rho$  is the average signal to noise ratio per receiver and

$H_{i,j}^k(n) = \sum_{l=0}^{L-1} \alpha_{i,j}^k(l) e^{-j2\pi n \Delta f \tau_l}$  is the subchannel gain. Here

$\Delta f = 1/T_s$  is the inter-subchannel space and  $T_s$  is the OFDM symbol period. The additive noise  $\omega_j^k(n)$  is modeled as independent complex Gaussian random variable with zero mean and unit variance.

### 3. SIMULATION RESULT

In this section, we conduct several simulation experiments to show the performance of the proposed scheme over MIMO channels. The simulations are tested on standard video sequence ‘‘Foreman’’ with 128 frames,

whose frames are in QCIF format with only luminance component. The source coding rate is at 0.93bpp.

We build a MIMO OFDM simulation system as introduced in Section 2. The channel code used is a 1/2 rate irregular LDPC code with a length of 6096 bits. The OFDM symbols are designed following the IEEE 802.11a standard. Specifically, each OFDM symbol occupies 64 sub-carriers, in which 52 sub-carriers may be used for transmitting QPSK data symbols. The frequency selective multipath channel model is referred to COST207 indoor model [14]. Finally, known timing and zero Carrier Frequency Offset (CFO) are given throughout simulations.

Figure 4 shows the PSNR performance of the proposed scheme. In the MIMO-OFDM system without channel coding, we can achieve a great improvement with 35% transmission loss. Moreover, by importing LDPC code, the SNR requirement is greatly reduced and the unequal transmission scheme still obtains a few dB PSNR gains. It can be seen that the proposed scheme outperforms the scheme without STBC. The main advantage of the proposed scheme is that it is simpler than existing schemes using power distribution or adaptive modulation to combat with multi-path fading in MIMO transmission system. Moreover, the proposed UEP scheme is more suitable for multiple antennas system than traditional UEP schemes based on channel coding. However, we should point out that although the proposed scheme can obtain improved performance with STBC to protect important bits, the transmission efficiency still drops with noticeable loss.

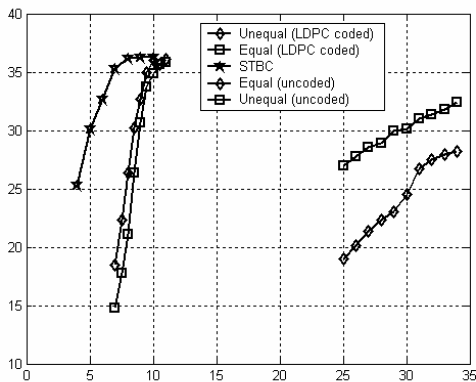

Fig 4. PSNR vs SNR comparison for EEP and UEP schemes.

#### 4. CONCLUSION

In this paper we have developed a new scheme for robust video transmission over MIMO-OFDM system using MDC scheme to improve the robustness of signal source and adopting various space time coding strategies to obtain unequal error protection during transmission. Experimental results have demonstrated that the proposed scheme can achieve the desired trade-off between received video quality and transmission efficiency. We believe such an integrated

approach will provide additional dimensions for optimal design of MIMO-OFDM wireless video communication systems.

#### ACKNOWLEDGEMENTS

This work is supported by China National Natural Science Foundation under Research Grant No. 60328103 and the Fujian Education Department Foundation Grant No. K04004.

#### REFERENCES

- [1] H. Zheng and K. J. R. Liu, "Space-time diversity for multimedia delivery over wireless channels," in *Proc. IEEE ISCAS*, Geneva, Switzerland, May, 2000.
- [2] H. Zheng and D. Samardzija, "Performance evaluation of indoor wireless systems using BLAST testbed," in *Proc. IEEE VTC*, Rhodes Island, Greece, May, 2001.
- [3] Z. Ji, Q. Zhang, et al., "Power Efficient MPEG-4 FGS Video Transmission over MIMO-OFDM Systems", *Proc. of ICC 2003 Conf.*, Vol. 5, pp. 3398- 3402.
- [4] Z. Ji, Q. Zhang, W. Zhu, J. Lu, and Y.-Q. Zhang, "Video broadcasting over MIMO-OFDM systems," *Proc. IEEE ISCAS*, v. 2, May 2003.
- [5] C. Kuo, C. Kim, C. -C. J. Kuo. "Robust video transmission over wideband wireless channel using space-time coded OFDM systems," in *Proc. WCNC'02*. vol. 2, pp. 931-936. Mar. 2002.
- [6] H. Zheng, L. Yu, C. W. Chen, "Robust Video Transmission based on Multiple Description Scalable Coding with EREC," *Proc. SPIE Visual Communications and Image Processing*, Vol. 5960 pp.1891-1902, July. 2005.
- [7] Y. Chen and W. A. Pearlman, "Three-dimensional subband coding of video using the zero-tree method," in *Proc. SPIE 2727— Visual Communications and Image Processing '96*, Mar. 1996, pp. 1302–1309.
- [8] C. D. Creusere, "A new method of robust image compression based on the embedded zerotree wavelet algorithm," *IEEE Trans. on Image Processing*, vol. 6, pp. 1436–1442, October 1997
- [9] B.-J. Kim and W. A. Pearlman, "An embedded wavelet video coder using three-dimensional set partitioning in hierarchical trees," in *Proc. Data Compression Conf.*, Mar. 1997, pp. 251–260.
- [10] D. W. Redmill and N. G. Kingsbury, "The EREC: An error-resilient technique for coding variable-length blocks of data," *IEEE Trans. on Image Processing*, vol. 5, pp. 565–574, April 1996
- [11] J. Liu and J. Li, "A simple soft-detector for the BLAST system", *Sensor Array and Multichannel Signal Processing Workshop Proceedings*, 2002, 4-6 pp.159 -163. Aug. 2002
- [12] C. Ru, L. Yin and J. Lu, "An LDPC coded MIMO-OFDM system with simple detection and channel estimation scheme", *Emerging Technologies: Frontiers of Mobile and Wireless Communication*, 2004. Proceedings of the IEEE 6th Circuits and Systems Symposium on Vol.2, pp.693 – 696, May. 2004
- [13] V. Tarokh, H. Jafarkhani, A. R. Calderbank, "Space-time block codes from orthogonal designs" *IEEE Transactions on Information Theory*, Vol. 45, Issue 5, July 1999 Page(s):1456 - 1467
- [14] "Digital Land Mobile Radio Communications - COST 207", Commission of the European Communities, Final Report, 14 Marzo, 1984--13 Settembre, 1988, Office for Official Publications of the European Communities, Luxembourg, 1989.