

# Force Sensing for Multi-legged Walking Robots: Theory and Experiments – Part 1: Overview and Force Sensing

A. Schneider, U. Schmucker  
Fraunhofer Institute for Factory Operation and Automation  
Germany,

## 1. Introduction

This paper is intended to direct the attention of researchers and designers of multi-legged walking robots to the problem of force sensing for such vehicles. The use of force information enables such systems to achieve new mechanical properties, increases the reliability and functional capabilities of walking robots and simplifies many control algorithms.

Interest in developing walking machines as vehicles with increased passability has picked up in the last sixty years. Walking machines have a number of principle advantages over wheeled and caterpillar machines:

- They can move over terrains with obstacles up to the size of a leg.
- The movement of their legs provides comfortable motion of the body with cargo and passengers over uneven terrain.
- Ground deformation under their support legs creates less of a mechanical load on the ground than a wheel or caterpillar machine's continuous track (especially important for tundra, mountain and hill slopes, forests, etc.).
- They can work in a complexly-structured environment (sloped, confined work and operation, etc.) and move on consolidating ground and unknown terrain with varying load capacity.
- They can use one or more legs as an auxiliary manipulator.

The advantages of walking machines determine their range of potential applications (Song & Waldron, 1989; Okhotsimsky *et al.*, 1992; Berns, 2006).

In order to achieve foot force distribution by any method, the vehicle legs have to be equipped with *force sensors*, as shown in Fig. 1.1, and *force feedback* should be introduced into the control system (Golubev *et al.*, 1979; McGhee *et al.*, 1980; Klein & Briggs, 1980; Devjanin *et al.*, 1982).

Basic areas of research on motion control for walking robots where *the use of force control is necessary* can be specified as follows:

### A. Local Regulation and Gait Cycle Correction of Legs

This section describes the organization of an adaptive step cycle for each leg to step over an unknown obstacle by means of touching movements (Gurfinkel *et al.*, 1981; Devjanin *et al.*, 1983; Steuer & Pfeiffer, 1998; Schmucker, 2002).

Source: Mobile Robots, Moving Intelligence, ISBN: 3-86611-284-X, Edited by Jonas Buchli, pp. 576, ARS/pIV, Germany, December 2006

Most step cycle organization is based on trajectories of movement of the end of a leg and has rigidly programmed kinematics. Modifying a step cycle (support and a transfer phases) on the basis of a leg's contact to an environment (tactile force sensor signals) significantly expands the possibilities to adapt a leg to the roughness of a support surface. An adaptive step cycle has been developed for the legs of a six-legged robot "Masha" (Devjanin *et al.*, 1983).

As the leg touches the ground, the vertical movement is stopped and the trajectory of the foot is modified so that the time of the complete cycle remains constant.

### **B. Force Motion Control of Legs in Interaction with a Support Surface**

One of the central problems of motion control is the distribution of force between legs and the organization of robot motion within margins of static stability. Support reactions need to be controlled during movements on rough terrain and to increase ground passability.

In terms of the foot forces acting on its legs, a multi-legged walking vehicle is a *statically indeterminate* mechanical system. For example, the horizontal components of support reactions cannot be determined in a support phase on three legs. If the number of supporting legs is greater than three, then the distribution of vertical force components cannot be determined.

Actively distributing foot force reactions makes it possible:

- to reduce loads on the vehicle structure and the *energy consumption* of leg drives,
- to increase vehicle passability on a surface with an insufficient load-bearing capability (e.g., sand),
- to generate locomotion over rough terrain and to overcome large obstacles (high ledges, deep holes, etc.),
- to provide control of the horizontal foot force components so that contact forces are within friction cones and
- to minimize the risk of foot slip.

The possibility of force distribution control in a walking vehicle has been in discussion for over twenty-five years. There are a number of approaches to the force distribution problem based on different criteria. At the same time, the problem of optimally distributing support reactions in real time presents significant difficulties. For instance, the movement of the six-legged vehicle consisting of a body and six legs each with two-elements is described by differential equations of the 48th order. Obviously, simplified models need to be developed. Various optimization algorithms for foot force distribution are known. These include: methods based on linear (Orin & Oh, 1981) and square-law programming (Okhot-simsky & Golubev, 1984; Klein & Kittivatcharapong, 1990; Cheng & Orin, 1990; Nagy *et al.*, 1992; Marhef & Orin, 1998):

- methods employing additional equations (Kumar & Waldron, 1988),
- methods based on pseudo-inverse approaches (Whitney, 1969; Klein & Wahavisan, 1984; Waldron, 1986; Kumar & Waldron, 1990; Gorinevsky & Shneider, 1990; Gardner, 1992; Lehtinen, 1994; Jiang *et al.*, 2004).

The use of linear or square-law programming to optimize the distribution of support reactions is complicated in practice because of the necessity to calculate the support reactions in real time. Therefore, most publications only contain simulation results.

*Pseudo-inverse methods* are widely used because they quickly solve foot force distribution in real-time. Most of these methods solve the equilibrium equations in terms of the foot forces, where the pseudo-inverse is used to minimize the sum of squares of the foot forces.

However, the exact condition of energy minimization is more complex (Okhotsimsky & Golubev, 1984).

Pseudo-inverse methods have been presented in connection with the concept of multi-fingered gripping. The *zero interaction force* concept for testing the ASV Hexapod was described by (Waldron, 1986) A more complicated version of *zero interaction force* was presented by (Kumar & Waldron, 1988). The results of computer simulation of vertical foot force distribution for the robot OSU Hexapod while moving by wave gait cycle are presented in e.g. (Klein & Wahavisan, 1984; Schmucker, 2002).

This method has been used to compute the programmed support reactions in (Gorinevsky & Shneider, 1990) and to experimentally demonstrate the distribution of vertical and horizontal foot force reactions for stiff and compliant grounds in real time (see section 4 for more detail).

In (Gardner, 1992), non-linear optimization techniques are used to calculate force distribution that minimizes the maximum ratio of tangential to normal forces at the points of foot contact for the ASV Hexapod. Force distribution is investigated for three tasks (standing on flat terrain, crossing a crest and moving along crest). The force distribution is optimized in such a way that the sum of the squares of the force values is minimized.

The pseudo-inverse method for distributing vertical foot force components in the machine MEGAT1 with fluid drive is described in (Lehtinen, 1994). The results of three pseudo-inverse formulations for real-time optimal foot force distribution (vertical reactions) and the simulation results for a hexapod machine with a tripod gait are presented in (Jiang *et al.*, 2004). The authors developed a method for minimizing the risk of foot slip when there are more than three supporting legs.

### **C. Force control of robot body maneuvering for service operations**

Most research work on the development and application of walking robots deals with their transportation capabilities. However, the use of such robots is not merely limited to the transportation of technological equipment. Another field of application for walking robots is their use as a multi-purpose chassis to perform civil engineering tasks like assembly, repair, emergency and rescue work, etc. The can be used to perform many tasks such as moving the robot in a narrow labyrinth or a pipeline or operation with process equipment, on the robot's body. Operations such as assembly, handling, drilling, repair and machining can be carried out by controlling contact forces caused by interaction with objects. These tasks may be also treated as *constrained motion problems*.

### **D. Force control of locomotion in problems of climbing and overcoming large obstacles**

One of walking robots' basic advantages over wheeled and caterpillar machines is their ability to move over difficult terrain, to overcome larger obstacles by climbing over them and to move over "hummocks", over stones, in a pipe, etc. (Song & Waldron, 1989; Galvez *et al.*, 2001; Kaneko *et al.*, 2002; Golubev & Korianov, 2003; Bretl *et al.*, 2004).

### **E. Problems of oscillation damping and movement stability**

When moving, the walking robot's state may become unstable and nonattenuating oscillations may develop in the system. The most widespread approach to describing walking robots' dynamics and control involves treating the motions of the legs and body separately (Okhotsimsky & Golubev, 1984; Gorinevsky & Shneider, 1987).

However, when the support reactions provide feedback, the control signals in each leg depend on the motion of the robot body and thus on the motions of the other legs.

Other sources of in-system oscillations can be the coefficient of gains, force feedback time delay, force sensor stiffness and body mass (Gorinevsky & Shneider, 1987, 1997; Schneider *et al.*, 2004).

This brief review of the major tasks and problems of motion control, maneuvering, service and other operations reveals that *force sensing* is one of the central problems in engineering highly functional walking robots. Nevertheless and despite the wealth of literature, very few studies have been published on experimental implementation of force control in legged locomotion and other operation.

Unfortunately, many applied problems of multi-legged robot force sensing and force feedback control and problems of force distribution of support reactions in real-time in particular have been insufficiently investigated. At present, it is clear that vehicle legs should be equipped with *force sensors* and that *force feedback* should be introduced into the control circuit.

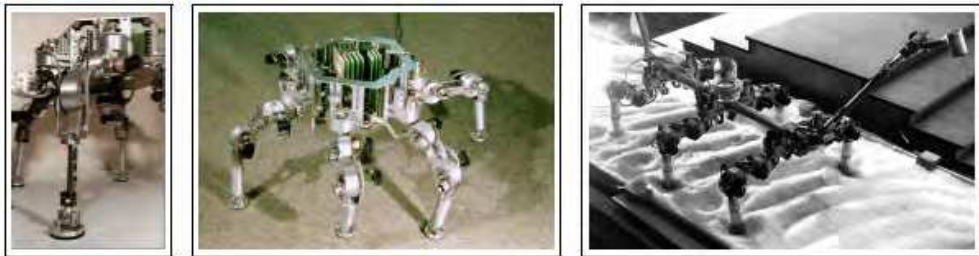

(a) Three  
Component  
force sensor

b) Six-legged robot "Katharina"

" (c) Six-legged robot "Masha"

Fig. 1.1. Illustration of three walking machines.

The results presented in this paper are based on the Fraunhofer Institute for Factory Operation and Automation's (IFF) development of the six-legged walking robot "Katharina" (weight about 25 kg) with a hexagonal body (Fig. 1.1b), which was equipped with an additional manipulator device with two degrees of freedom (Schmucker *et al.*, 1997). Some results were obtained earlier during the development of the "Katharina" prototype, "Masha", a six-legged walking robot (weight about 22 kg) with a rectangular body (Fig. 1.1c) (Gurfinkel *et al.*, 1982). Both vehicles have six legs each with three powered degrees of freedom and equipped with three-component force sensors mounted in the shanks (s. Fig. 1.1a). The manipulator has three-component force sensors as well.

In Section 3 of this paper, we present approaches to the development of force sensors for multi-legged machines. In Section 4, we describe the basic structure of the control system for the robot "Katharina". In Section 5, we consider fundamental force control laws and adduce our own experimental analyses of force control distribution. In Section 6, we report the results of some experiments on locomotion over soft soil. In Section 7, we describe the service operations that have been performed using body displacement and force control.

## 2. Survey of statically stable walking machines

In the history of scientific research there are many examples of designing robotic devices like mechanical toys and anthropoid robots. For example, in the 4th century in China was

built a mechanical crow. Design studies of Leonardo da Vinci and the development of mechanical dolls with human-like behaviour in the middle age may be regarded as groundwork for legged locomotion. For more information, see Thring, 1983; Todd, 1985; Marsh, 1985; Raibert, 1986; Song & Waldron, 1989; Vukobratovic *et al.*, 1990; Okhotsimsky *et al.*, 1992; Rosheim, 1994; Berns, 2006, and other.

One of first walking mechanisms appeared about 1870. The famous Russian mathematician Chebyshev has developed a *four-legs plantigrade mechanism*. His “foot-walking” machine is a combination of several four-link mechanisms and is the prototype of walking mechanisms constructed on the basis of the so-called trajectory synthesis, where the coordination of extremities movement “is fulfilled in a purely mechanical way” (Chebyshev,1945).

In 1893 George Moore constructed the first biped machine, the so-called *Stearn Man* (s. Rosheim,1994).

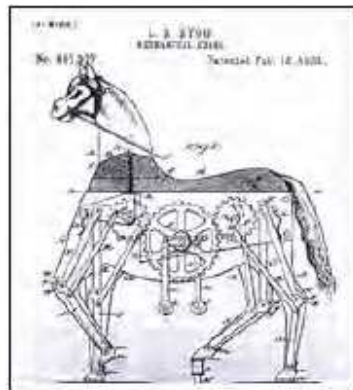

Fig. 2.1. The mechanical Horse.

In the same year, Lewis A. Rygg filed a patent for the construction plans of his *Mechanical Horse* (Fig. 2.1), a four-legged machine with a steering concept similarly to a bike: the driver should move the machine through pedals (Rygg, 1893). However, this machine was never built. The same happened to the *Schreitwagen* of Freiherr von Bechtolsheim designed in 1913. In the following years different walking machines have been constructed, which all were based on the simple mechanical hardware, where the locomotion was reached through a cyclic up and down movement of a mechanism with only one degree of freedom.

Other examples are a mechanism constructed during the First World War (Shigley, 1961), a centipede and a leg driven tractor designed by Thring (Thring, 1983).

## 2.1 The first steps of development of multi-legged walking machines (from 50ies till 70ies)

The first mechanical constructions were based on a predetermined movement so that an adaptation to the ground was not possible. To obtain more flexibility several researches in fifties started to assign the motion control of the walking machine completely to a human operator by controlling the different degrees of freedom manually.

A lot of research concerning legged locomotion was done from Bekker and his colleagues at the University of Michigan and at the US Army Tank Automative Center at Warren, Michigan. Bekker has studied land locomotion for many wheels and walking modes (Bekker, 1969).



Fig. 2.2. GE Quadruped of Mosher.

One of the most advanced machines was the four legged machine *G.E Quadruped*, the General Electric Walking Truck of R. Mosher (Fig. 2.2). This machine was more than 3 meters high and 3 meter long, with a weight of more than 1.400 kg, and was controlled by operator's hands and feet through a bi-lateral force reflecting hydraulic servo system (Mosher, 1968).

Due to the rapid development in space exploration at the end of the 60ies, the NASA ordered new studies concerning the development of machines for planetary exploration. At this period, six- and eight-legged vehicles moving with tripod- and tetrapod-gait were constructed, like for example the eight-legged *Iron Mule Train* (Todd, 1985; Morrison, 1968).

In 1960-1961, Shigley used a hydraulically driven pantographe mechanism to transfer the motion of a horizontal and a vertical actuator. The design had 16 legs, a block of four at each corner (Shigley, 1961). The 70ies are characterized by intensive theoretical research of locomotion of human and animals, mathematical modeling of walking devices on a complex surface, development of a big number of physical models. During this period, the most important results have been received in the research centers of the USA, the USSR and Japan.

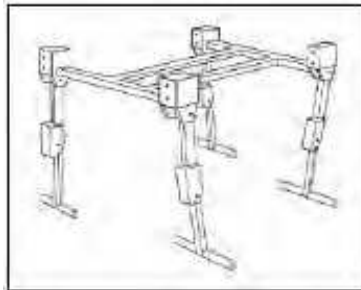

Fig. 2.3. Phony Pony.

In 1966, a four-legged machine named "*Phony Pony*" (Fig. 2.3) was built by Frank and McGhee at the University of Southern California (McGhee, 1976). Each leg had two degrees of freedom. Both joints were actuated by electric motors with gears. Using the method of finite-state control, two types of walking were investigated: the quadruped walk and the quadruped trot. It was only a walking in a straight line. This was the *first legged vehicle which walked autonomously under full computer control*.

Tomovic and McGhee suggested to use the method of finite-state control for a description of a four-legged vehicle movement. In terms of this approach McGhee has developed a four-legged device with pneumatic drives (Tomovic & R, 1966).

In 1968, Morrison constructed a number of six- and eight legged vehicles variants with execution of alternating tripod and tetrapod gaits (Morrison, 1968). Mossi and Peternelle built in 1969 at the University of Rome an electrical hexapod. Its legs were unusual in employing telescopic joints for the vertical motion; they were pivoted at the hip to provide the propulsion stroke (Mocci *et al.*, 1973; Peternella & Salinari, 1973).



Fig. 2.4. Hexapod of McGhee.

In 1977, McGhee and his group at Ohio State University developed the *OSU-Hexapod*, a six-legged insect-like machine (Fig. 2.4). This vehicle was equipped with force sensors, gyroscopes, proximity sensors and a camera system and was fully controlled by a PDP 11/70. Active force sensing has been used in the control system.

The parameters of the machine are as follows: body length 1,3 m body width 1,4 m, weight about 100 kg, velocity about 0,1 m/s (McGhee, 1977; McGhee & Iswandhi, 1979; Klein & Briggs, 1980).

It has been used for a variety of experiments, like walking with different gaits on a flat surface, climbing up shallow stairs and walking over obstacles (Ozguner *et al.*, 1984). These results in building optimal leg construction and the developed theory of walking layed the basis for the biggest walking machine project at that time. In 1982, Waldron and his group at Ohio State University started with realization of the *Adaptive Suspension Vehicle (ASV)* (Fig. 2.5). The aim of the project was an easily steerable, big and efficient machine that could be used at natural ground conditions (Song & Waldron, 1989).



Fig. 2.5. ASV – The Adaptive Suspension Vehicle.

The ASV is 5,2 m long and 3 m high. It reaches a stride length of 1,8 m and a maximum velocity of 3 m per second. However, the mobility of this machine was considerable. The ASV is able to surmount obstacles up to 1 m and to walk on slopes up to 37%.

The project of development of *Ambler* (Fig. 2.6) started in the late 80th aiming at planetary exploration (Bares *et al.*, 1989; Simmons & Krotkov, 1991).

The researchers intended to construct a machine which is fault tolerant to a break-down of mechanical devices, which possesses an autonomous energy supply and particularly, they wanted to have a machine that could work in a completely autonomous way. The operator of the machine should only prescribe more complicated tasks, but the machine should perform the tasks completely on its own.



Fig. 2.6. Walking machine Ambler.

In 1969, the largest off-road vehicle in the world, a coal-mining dragline called "*Big Muskie*" was build and applied in coal mining.

An eight-legged machine named *ReCUS* was constructed in 1979 and used for underwater measurements of ground profiles for the construction of harbours (Ishino *et al.*, 1983).

For similar applications, the six-legged walking machine *Aquarobots* was developed later (Akozono *et al.*, 1989).

The series of six-legged machines *Odex* with their six legs arranged in a circle are similar to the *Aquarobot*. The first model of the *Odex* was presented in 1983, it was determined for maintainance work in nuclear power plants (Fig. 2.12). The robot was steered in a teleoperation modus by an operator who determined the tasks of the robot (Byrd & DeVries, 1990).



Fig. 2.7. Hexapod Odex.



During this period, a number of industrial and research companies in Japan were developing walking robots for application in various areas of the national economy. During the 80ies several four-legged machines have been developed which were controlled by a simple steering of the machines body, e.g., *Titan 1-1V* (Fig. 2.8) (Hirose, 1984), *PV 11* (Hirose & Umetani, 1980), and *Collie* (Miura *et al.*, 1985; Emura & Arakawa, 1991). The *Titan* series and the *PV-11* are four-legged machines with an insect-like leg construction.

Their automated steering devices make the machines easier to handle rather than a manual steering. However, they showed big disadvantages in terms of moving velocity and the energy efficiency. The robot *Collie 1* had a mammal-like structure, but its moving possibilities have been that restricted, that a dynamically stable walking was possible only in one direction.

The electromechanical four-legged machine *PV-11* has been designed at the Tokyo Institute of Technology. Its weight was 10 kg. The legs are special pantograph mechanisms. A larger model (weight about 150 kg) with similar kinematics has been elaborated and tested (Hirose & Umetani, 1980; Hirose, 1984; Umetani *et al.*, 1985). In 1985, the Laboratory of mechanical Engineering (Japan) designed an electromechanical walking robot *MELWALK3*. Its parameters are as follows: weight 35 kg, body length 0,5 m (Kaneko *et al.*, 1988).

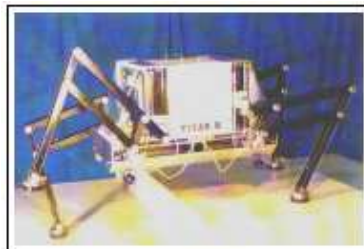

Fig. 2.8. TITAN-2.

Intensive researches have begun at the end of the 60ies in Russia in the field of the theory and development of walking robots of various applications (Artobolevsky & Umnov, 1969). There was published a series of papers about various periodic gaits and optimal gaits for a hexapod (Bessonov & Umnov, 1973).

In 1972, the first Russian walking devices *Ricksha* with two legs has been developed and different gaits have been studied, as well as the interaction between legs (Devjanin *et al.*, 1973; Schneider *et al.*, 1974).

In 1974, a hexapod with legs arranged radially about a central vertical axis was made in the Aviation Instrument Institute in Saint-Petersburg. No information on its tests is available (Ignatyev *et al.*, 1974).

In the early 70s, at the Institute of Applied mathematics (IPM) of the Russian Academy of Sciences in Moscow, a six-legged walking machine controlled on a base of a *mathematical model* of motion control was developed. The machine motion and the terrain were rendered on a display. Motion control algorithms were developed for a walking machine on rugged terrain in both automated and operator control modes. The problems of control were also considered for a dynamic model of a statically stable walking machine (Okhotsimski & Platonov, 1973, 1976).

Two laboratory models of electromechanical walking machines and control systems (1977, 1979) were designed at the Institute of Applied Mathematics (IPM) in collaboration with the

St. Petersburg Mechanical Institute. The machines were tested in supervisory and automated modes.

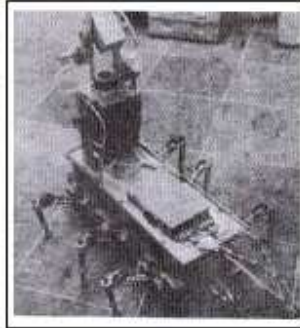

Fig. 2.9. Hexapod IPM.

The *first* six-legged machine was equipped with a laser scanning range finder and is connected with a two-computer system. The walker could move around isolated obstacles which were detected remotely by a scanning distance-measuring system, and could climb over obstacles (see Fig. 2.9).

The parameters of the machine are the follows: body length 0,6 m, body width 0,25 m, weight 56 kg, length of leg 0,4 m, velocity 0,2 m/s (Okhotsimski & Platonov, 1976; Okhotsimski *et al.*, 1978).

A second mechanical model of this robot was developed at the Institute VNIITRANSMASH (St. Petersburg). The parameters of the machine are the follows: body length 0,6 m and body width 0,25 m, weight 40 kg, length of leg 0,4 m (Efimov *et al.*, 1982).

The joint researches resulted in the development of the full-scale six-legged *walking rover* controlled by the human-operator (Fig. 2.10) at VNIITRANSMASH Institute (St. Petersburg) in 1985. Its weight is 450 kg, the machine is equipped with a generator, storage batteries, a control system, and an armchair with joystick for the operator (Kemurdjian, 1995).



Fig. 2.10. Walking Rover (St. Petersburg).

In 1978, the laboratory prototype of an electro-mechanical walking machine at the Institute of Machine Engineering, Moscow, was able to move at a fixed gait with a given step length and clearance. Its simple control system was based on a PLC-like device. The legs are constructed in an orthogonal kinematics scheme with two degrees of freedom (Umnov, 1981).

At end of the 60ies and at the beginning of the 70ies in Moscow there was constructed the six-legged insect-like walking robot “Masha” (Fig. 2.11).

Robot Masha has six legs, with three powered degrees of freedom each. The control system was based first on a general-purpose analog computer and later on an onboard special-purpose computer. The machine was equipped with a triangular range finder, a vertical gyro and force sensors in each leg which measured the three components of the support reaction and ground contact sensors.



Fig. 2.11. Robot “Masha”.

The legs are powered by electric drives with gears and are equipped with joint angle potentiometer sensors.

The triangular optical range finder mounted on the front of the body determined the coordinates of obstacles. A scanning was performed by rotating mirrors. Active force sensing has been used at the control system. The control problems of vehicles moving on deformable grounds were analysed and studied experimentally.

The machine was tested in supervisory (a human operator) and automated (with a range finder) control modes. The locomotion, including by-passing and climbing over obstacles (including the stair-type ones) was controlled automatically. The main geometric and mass parameters of the machine are as follows: the body length 0,7 m and width 0,21 m correspondingly, length of leg 0,28 m, mass is 22 kg, maximal speed 0,25 m/s (Gurfinkel *et al.*, 1981; Gurfinkel *et al.*, 1982; Devjanin *et al.*, 1983).

### **Present research of multi-legged robots**

The 90ies are characterized by a rapid development of theory of multi-legged walking machines, control systems based on classical and on neural networks theory, particularly in the USA, Europe and in Japan. Walking machines are equipped with various sensing systems. Furthermore, AI systems were widely applied to the analysis of an environment and motion of robots on a complex surface.

In 1993, the NASA financed the *Daedalus-project*, which had a similar objective like the *Ambler-project* (Roston, 1994).

The *Dante-project* is one of the few big projects of the 90ies. Under the leadership of Prof. Wittaker two eight-legged robots (*Dante 1 and Dante 2*) for the locomotion on very rough terrain on earth or any other planet have been developed at CMU (Field Robotics Center,

US). *Dante 2* had the task to climb in the crater of the Mound Spurr Vulcano (Alaska, USA) to take measurements of the consistency of gas near the crater bottom.



Fig. 2.12. Dante 2; CMU, USA.

A quadruped machine, intended for the investigation of different gaits of mammal like machines was constructed by Inagaki and Kobayashi (Inagaki & Kobayashi, 1993). Prof. Bekey and his group at University of Southern California, LA developed the quadruped *Meno 2* (Sukhatme & Bekey, 1995).

In the 80-90ies, a big variety of two-, -four- and six-legged walking machines was developed, mostly as research robots for basic investigation of locomotion and behavior, for the construction of walking machines, control systems, and for use in service operations. Features of the developed machines can be found in numerous publications, e.g., in transactions works of annual conferences CLAWAR.

The work of Prof. Cruse and his research group on the walking behavior of the stick insect as well as on the role of neural synapses in control of movements inspired several projects to transfer the results of those studies to walking machines (Cruse *et al.*, 1998).

The six-legged walking machine of the Technical University of Munich (TUM), for example, is a result of this idea (Pfeiffer, *et al.*, 1994). The machine is designed and steered similar to a stick insect (Pfeiffer *et al.*, 1995). The control system was realized as a neural structure.

In the 90ies, research and development of multi-legged walking machines were intensively performed in European countries. Some examples of the most known walking machines are shown in Fig. 2.13. Their description and characteristics can be found in the catalogue of walking machines (Berns, 2006) and, e.g., in literature (Pfeiffer *et al.*, 1994; Schmucker *et al.*, 1996; Berns *et al.*, 1998; Roßman & Pfeiffer, 1998; De Santos *et al.*, 2003; Halme *et al.*, 1994; Kirschner & Spennberg, 2001); Arikawa & Hirose, 1996; Hirose *et al.*, 1991; Galvez *et al.*, 2001).

When the speed of walking machines increases, it is more advantageous from energy point of view to pass from statically stable to dynamic modes of motion, as animals do. This transition to dynamic modes makes it possible to increase relative duration of the leg transfer phase, to decrease the frequency of leg oscillations with respect to the body, and to reduce power consumption on the leg motion relative to the body.



(a) Robot *Katharina* (25 kg) with hexagonal body. IFF Magdeburg.

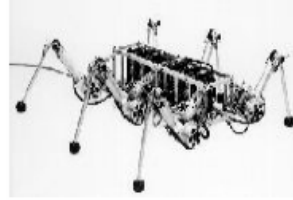

(b) *TUM Walking Machine* (23 kg) with rectangular body. TU, Munich.



(c) *Lauron* (12 kg) with rectangular body. FZI, Karlsruhe.



(d) Four-legged walking machine *SILO4* (67 kg). CSIC, Madrid.



(e) Eight-legged robot *Skorpion* (9,5 kg). Inst. for Autonomous Intelligent Systems (AiS), Sankt Augustin.



(f) Six-legged robot *Silex* (15 kg). Free University, Brussels.

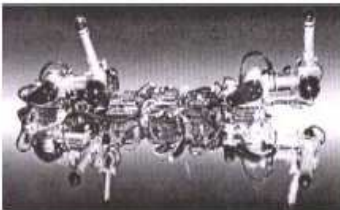

(g) *TUM Pipe Crawling Robot* (20 kg) with 8 legs. TU, Munich.



(h) Four-legged robot *TITAN-6* (160 kg). Tokyo Inst. Technology, Japan.



(i) *Walking Machine Fa*. Plustech Oy. Finland

Fig. 2.13. Multi-legged walking machines developed in Europe.



Fig. 2.14. Big Dog of Robotics Boston Dynamics.

This determines the importance of research in mechanics and motion control and in design of legged vehicles with dynamically stable locomotion. A considerable part of the studies dealing with dynamic stable motion of legged vehicles was purely theoretical or was done by methods of mathematical modeling and simulation.

One of the first who constructed walking machines exclusively for investigation of dynamic walking behavior was Raibert. He first started with experiments with one-legged machines in 1983. His *2D*- and *3D-Hopping Machines* are very robust to external disturbances (Raibert, 1986).

As an example, the research company Robotics Boston Dynamics developed a dynamically stable four-legged walking machine *BigDog*, with a size of a greater dog which can bear a cargo in weight up to 55 kg (Fig. 2.14), (<http://www.bostondynamics.com>).

### 3. Force sensors

Forces and torques are measured by *deformation or displacement* in an elastic mechanical element of a sensor. Various physical principles are employed to convert these quantities into sensor output (Baumann, 1976). The theory of force sensors, design specification, their parameters and engineering methods of calculation are presented for example in (Green & Zerna, 1968; Bray *et al.*, 1990; Gorinevsky *et al.*, 1997). The majority of force sensors established in robotics use strain gauge transducers.

#### 3.1 Fundamentals of force sensors design

At present, only a relatively small number of multi-legged walking robots have foot force sensors and force control systems. Possible reasons might be the great variety of designs of walking vehicles, their different leg and foot structures and differing loads on supporting legs that do not allow the use of commercial force sensors in many cases.

In many cases, gimbals connect the feet to the shin and thus force sensors measure only three components of the support reaction. There are also force sensors that measure five and six components of the support reaction. These are necessary for example for robot climbing of (Galvez *et al.*, 2001).

The basic types of force sensors and their elastic elements are the *bending element* (Fig. 3.1a), *double bending beam element* (Fig. 3.1b), *parallelogram elastic element* (Fig. 3.1c), *Maltese cross*

element with elastic beam support (Fig. 3.1d) and their modifications. Some typical force sensors with one, three and six components were designed for application in legged robots for various carrying capacities. More detailed information on force sensor designs and parameters can be found in (Gorinevsky *et al.*, 1986, 1997). The basic characteristics: *sensitivity, stiffness eigenfrequency, decoupling, linearity, and hysteresis* were used to evaluate and compare the designs developed for force sensors. Strain gauge transducers were used to measure deformations of elastic elements (Fig. 3.1). Many multi-component force sensors are composed of one or two-component modular elements. Such modules should only be sensitive to the component desired from among the multiple components of force and torque acting on it. The modular elements are usually designed to be *mechanically decoupled*, i.e. to have a selective mechanical response to the measured components.

### 3.2 Design computations for multi-component sensors

#### 3.2.1 Six-component sensors with bending elastic elements

Elastic elements consisting of bending and torsion deformations are typically used to measure moderate loads (less than 1000 N).

We consider the main parameters of the sensors: their sensitivity and stiffness *Sensitivity*. The vector of average strains in strain gauge bridges is linearly dependent on the components of the attached load provided that bending or torsion strain is measured. We can then write  $\varepsilon = \frac{L}{Eh^3} \lambda \left[ \frac{F}{M/L} \right]$  where  $\lambda$  is the nondimensional sensitivity matrix of the sensor,  $L$  the characteristic beam length,  $h$  the beam cross-sectional dimension (thickness) and  $\zeta = L/D$  the nondimensional ratio of the characteristic beam length to the end-effector size.

				
Sensitivity ( $\varepsilon$ )	$\varepsilon = 6Fl / (Eah^2)$	$\varepsilon = Flh_{eff} / (8EI_y)$	$\varepsilon_{(11)} = \bar{F}(1 + \mu) / (4lsE)$	$\varepsilon_x = \beta_x \frac{FL}{Eh^3} \geq \varepsilon_0$
Stiffness ( $\delta$ )	$\delta = 2El / h$	$\delta = \varepsilon l^2 / (3h_{eff})$	$\varepsilon_c^{(11)} = F_c / (4Es)$	$\varepsilon_y = \beta_y \frac{FL}{Eh^3} \geq \varepsilon_0$
Eigenfrequency ( $\nu$ )	$\mathcal{G}_1 = 2h\Delta / a^2$ $\mathcal{G}_2 = 2(1 + \mu)\nu$	$\nu = 1 / \pi \sqrt{6EI_y g / (Fl^3)}$ $\mathcal{G}_1(M_x) = 8\Delta DI_y / (lh_{eff} I_x)$ $\mathcal{G}_2(M_y) = 8\eta DI_y / (stdh_{eff})$	$\xi = \frac{L}{Eh^3} K^{-1} \left[ \frac{\bar{F}}{M/L} \right]$ $\nu = \Omega \cdot f / (2\pi)$	$\delta = \frac{\bar{F}}{Eh^3} 4l^2$

Fig. 3.1. Basic designs of elastic elements used in forces sensors (Gorinevsky *et al.*, 1997).

Stiffness. The external force  $\bar{F}$  and torque  $\bar{M}$  cause small linear displacement vectors  $\delta$  and angular displacement vectors  $\varphi$  in the elastic element of the sensor, which are linearly

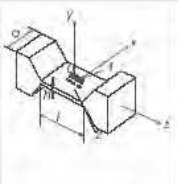
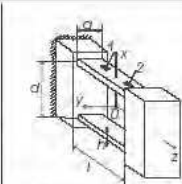
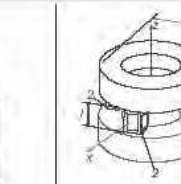
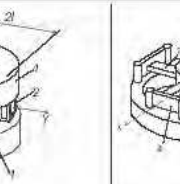

dependent on  $\bar{F}$  and  $\bar{M}$ . Let  $\xi = [\delta^T, \varphi^T L]^T$  be a six-dimensional vector of generalized coordinates. Then we can write  $\xi = \frac{L}{Eks} K^{-1} \left[ \frac{\bar{F}}{\bar{M}/L} \right]$  where  $K^{-1}$  is the nondimensional compliance matrix.

*Maltese cross* elastic elements (s. Fig. 3.1d) consist of four radial beams of the length  $l$ , which connect a rigid hub 2 of the radius  $r$  with an outer flange 3. The outer edges of the beams rest upon the flange via membrane joints 4, which restrain the beam ends from rotation and transversal displacement. Thus we can denote  $L = r + l, \alpha = r/l$ .

### 3.2.2 Compressive-tensile and shear elastic module

This elastic module is generally employed to measure comparatively large loads (exceeding 500 N). The design of the sensor is shown in Fig. 3.1c. Two round flanges 1 are linked by four ( $n1, \dots, 4$ ) elastic struts uniformly positioned along the circumference. The length of each strut is  $l$ ; the cross-sectional area is  $s$  and the distance  $2L$  between the diametrically opposite struts is far greater than the strut dimensions.

## 3.3 Examples of force sensor designs

### 3.3.1 Sensors with bending deformation

To measure the longitudinal component of the support reaction not exceeding 500 N, we developed a compact parallelogram elastic module in which, to reduce the cross sizes, force measuring elastic plates are located in the plane parallel to the action of the longitudinal force. Fig. 3.2 shows the circuit of such a module. External (1) and internal (2) flanges are attached to the top of the elastic plates (3, 4); the bottom ends of the plates are connected with a rigid non-deformable crosspiece (5) in which a hole (6) is made on the symmetric axis of the module. A force-transfer element (7) passes through this hole. The element is connected to an internal flange. Strain gauges (8, 9) are mounted along an axial line on the outside of the plates and measure elastic bending deformations.

The module is mechanically insensitive to torques because the strains caused by lateral components of a supporting reaction in the plates have identical signs. Fig. 3.3a and Fig. 3.3b shows the three-component force sensor developed at the Fraunhofer IFF and integrated in legs of the walking robot "Katharina" with a load carrying capacity of about 24 kg.

It consists of a bending beam with a quadratic cross section for measuring lateral components of the support reaction and the module described above for measuring the longitudinal component. The holes are used to form elastic beam plates.

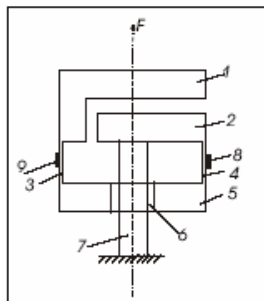

Fig. 3.2. An axial module.



The holes concentrate stress on plates where strain gauges are attached. The module is made of an integral piece of metal, is simple to manufacture and has a small coupling.

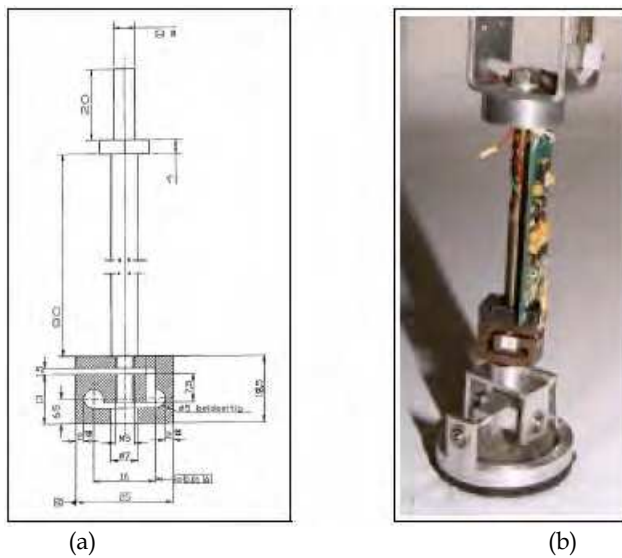

Fig. 3.3. Design of three-component force sensor.

Together with the amplifier, this sensor is mounted in the shank of a leg and the bottom end of the sensor is attached to a gimbal connected to the foot (see Fig. 3.3b). It is designed to be loaded up to 500 N, interference between channels not exceeding 1%. Fig. 3.4 and Fig. 3.5 show the technical solution of the three-component force sensor mounted on a manipulator.

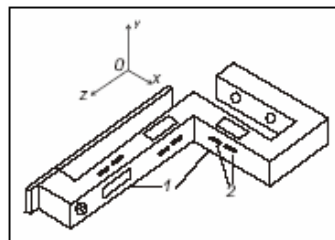

Fig. 3.4. Three-component force sensor composed of parallelogram element.



Fig. 3.5. Three-component force sensor mounted between the arm manipulator and a tool.

### 3.3.2 Sensor with a compressive-tensile and shear elastic element

Elastic elements of this type are generally employed to measure comparatively large loads (exceeding 500 N).



Fig. 3.6. Three-component force sensor for high loading.

Fig. 3.6 shows the three-component force sensor for the large four-legged walking machine “ALDURO” with a load-carrying capacity of about 700 kg. The sensor is made of a heavy-walled pipe (aluminum alloy D16T) in which four elastic beams have been milled. Strain deformations are measured by eight strain gauge rosettes mounted on lateral surfaces of beams and by four strain gauges mounted on the outsides of each beam. One flange of the sensor is attached to a leg shin, another to the articulated foot joint. Manufactured from an aluminum alloy, the sensor is mounted in the foot of a leg and designed for loads up to 3000 N. The beams have a length of  $l = 20\text{mm}$ ,  $r = 30\text{mm}$ , a diameter of  $90\text{mm}$  and a height of  $50\text{mm}$ . The cross-sectional area of the elastic struts measures  $126\text{mm}^2$ .

## 4. Control system structure

In developing the architecture for the control system, we used data from human and animal biomechanics and the control/organization of their motions. The contributions of N. A. Bernstein, 1967 and his followers (Gurfinkel & Fomin, 1973;

Shik & Orlovsky, 1976) connecting a multilevel organization of control in the locomotion system, a central program of movements and interlevel interaction are essential for engineering a walking robot’s control system.

The control system of the robot “Katharina” (Fig. 4.1) consists of upper and lower levels and is based on the idea of the synergy of the quasi-regular gait.

The *upper level* of the control system is supervisory and prescribes such motion parameters as components of linear and angular velocities of the body, gait pattern, track, width, clearance and some cycle parameters of locomotion. Algorithms of the *lower level* are based on the assumption that the vehicle moves slowly enough that its motion can be described kinematically. The *lower level* is made up of a main controller and six leg controllers. The local controllers are connected to the main controller that is connected to a PC by a serial link. All controllers are located inside the robot’s body. The **main controller** contains five basic units: master step cycle generator, step cycle modification unit, coordinate transformation unit, sensor signal evaluation and six leg transformation units.

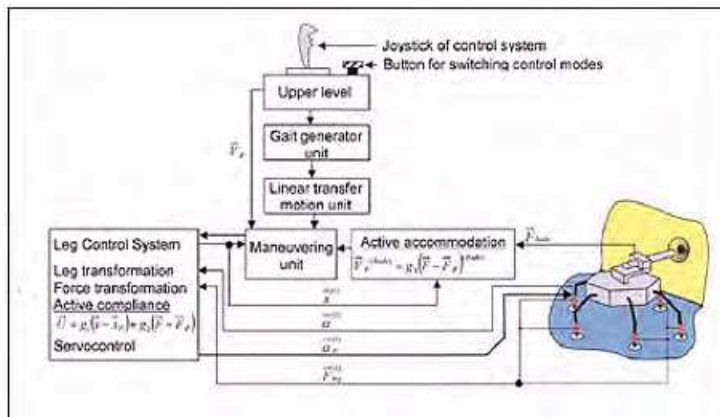

Fig. 4.1. Block-scheme of control system.

*The master step cycle generator.* The tip of each leg moves relative to the vehicle's body along a closed trajectory called a "step cycle". The unit contains one generator that creates prototypes of plane step cycles for each leg in some auxiliary Cartesian coordinates. The step cycles are interrelated to preserve given relationships between step cycle phases and a sequence of states of the legs.

*The step cycle modification unit.* This unit has several functions. A global modification subunit modifies global geometric parameters (vertical and horizontal) of step cycles (Devjanin *et al.*, 1983; Schmucker *et al.*, 2002).

An individual modification subunit activates changes for each step cycle individually. A step cycle consists of a support phase and a transfer phase. The transfer phase consist of three subphases: intrinsic transfer phase, lifting phase of a leg from a surface and lowering phase of a leg to a surface. A transition from the transfer phase to the support phase takes place either after the lowering phase finishes or when signals are received from force sensors indicating the moment when the leg encounters an obstacle.

*The coordinate transformation unit* geometrically links prototype trajectories with the body scheme, scales them and shifts trajectories linearly and angularly in the transfer phase.

*Sensor Signal Evaluation.* This unit operates with force and angle signals and calculates the algorithms of ground detection, force distribution between the legs locomoting over hard and soft surfaces and obstacle crossing. This unit handles internal and external sensor data collectively.

*Six leg transformation units.* These units have the six cycle generators as input and produce the programmed trajectories for each leg in Cartesian coordinates of axes  $\vec{x}_1^{(i)} \vec{x}_2^{(i)} \vec{x}_3^{(i)}$  the origins of which coincide with a leg's point of attachment.

The **leg controllers** contain the local leg transformation unit, the sensor transformation unit and the leg control system.

The *local leg transformation unit* transforms Cartesian coordinates of programmed vectors  $\vec{x}_p^{(i)}$  into the programmed vectors of joint angles  $\vec{\alpha}_p^{(i)}$ . The *sensor transformation unit* transforms the force vector  $\vec{F}_y^{(i)}$  measured by force sensor in the shanks into vector  $\vec{F}_x^{(i)}$  in axes  $\vec{x}^{(i)}$  and the vector of measured angles  $\vec{\alpha}^{(i)}$  into the vector  $\vec{x}^{(i)}$  in Cartesian coordinates. The *leg control unit* consists of the three-dimensional position servo control system for each leg.

The control system algorithms and their technical realization for the robots "Masha" and "Katharina" are described in (Schmucker et al., 1996; Schmucker, 2002).

Each leg of "Katharina" has its own controller based on a microcontroller INTEL 87C196KR which only controls the respective leg. The controller includes the CPU, FLASH-memory and RAM, a PWM output unit (PWM-U), analog input unit (AIU) and a synchronous serial communication unit (SSCU) on the chip. All microcontroller units are connected by a synchronous serial bus.

## 5. References

- Akozono, J., Iwasaki, M. & Asakura, O.(1989). Development on a walking robot for underwater inspection. In *ICAR' 89*. Columbus, Ohio, USA.
- Arikawa, K. & Hirose, S.(1996). Development of quadruped walking robot titan. In 8. *Proc. of IEEE/RSJ Int. Conf. on Intelligent Robots and Systems*, pp. 208–214.
- Artobolevsky, I. I. & Umnov, N.(1969). Some problems of elaboration the walking machines. *Bulletin of Russian Academy of Sciences* 2.
- Bares, J., Hebert, M., Kande, T., Krotkov, E., Mitchell, T., Simmons, R. & Whittaker, W.(1989). Ambler and autonomous rover for planetary exploration. *The Institut of Electrical and Electronics Engineers* 22 (6).
- Baumann, E.(1976). *Elektrische Kraftmesstechnik*. VEB Verlag Technik Berlin.
- Bekker, M.(1969). *Introduction to Terrain-Vehicle Systems*. University of Michigan Press.
- Berns, K.(2006). The walking machine catalogue.
- Berns, K., Kepplin, V. & Dillmann, R.(1998). *Terrain and obstacle detection for walking machines using a stereo-camera-head*, , vol. 2. Aachen, Germany: IECON'98.
- Bessonov, V. & Umnov, N.(1973). The analysis of gaits in six-legged vehicles according to their static stability. In *1st CISM-IFTOMM Symp. on Theory & Practice of Robots & Manipulators*.
- Bray, A., Barbato, G. & Levi, R.(1990). *Theory and Practice of Force Measurement*. Academic Press Limited.
- Bretl, T., Lall, S., Latombe, J.-C. & Rock, S.(2004). Multi-step motion planning for free-climbing robots. In *Workshop on the Algorithmic Foundations on the Robotics (WAFR)*, pp. 1–16. Utrecht, Netherlands.
- Byrd, J. & DeVries, K.(1990). A six-legged telerobot for nuclear applications development. *Int. J. Robot. Res.* 9 (2), 43–52.
- Chebyshev, P.(1945). *Research heritage of Chebyshev, issue, Theory of Mechanisms*. M.-L., Publishing House Academy of Sciences USSR.
- Cheng, F. & Orin, D.(1990). Efficient algorithm for optimal force distribution -the compact-dual lp method.. *IEEE Trans. on Robotics and Automation* 6 (2), 178–187.
- De Santos, P., Galvwez, J., Estremera, J. & Garcia, E. (2003). Silo4: a true walking robot for the comparative study of walking machine techniques. *Robotics and Automation Magazine, IEEE* 10 (4), 23–32.
- Devjanin, E., Gurfinkel, V., Gerfinkel, E., Kartashev, V., Lensky, A., Shneider, A. & Shtilman, L.(1983). The sixlegged walking robot capable of terrain adaptation. *Mechanism and Machine* 18 (4), 257–260.
- Devjanin, E., Kartashev, V., Lensky, A. & Schneider, A. Y.(1982). "Investigation of robotics", chap. Force feedback control of legged vehicle, pp. 147–158. Moscow (in Russian): Press "Nauka".

- Devjanin, E., Lensky, A., Samsonov, V. & Shtil'man, L.(1973). Elaboration of a model of the walking vehicle and correspondin control system. In *Proc. of V IFAC symp. on Automation Control in Space*. Genujy, Italy.
- Efimov, V., Kudriasev, M. & Titov, A.(1982). *Investigation of Robotics Systems*, chap. A Physical Similar of Motion Walking Apparatus, pp. 86-91. Moscow, (in Russian): Publishing "Nauka.
- Emura, T. & Arakawa, A.(1991). Attitude control of a quadrupped robot during two legs supporting. In *Inter.Confer.on Advanced Robotics*. Pisa, Italy.
- Galvez, J., de Santos, P. G. & Pfeiffer, F.(2001). Intrinsic tactile sensing for the optimization of force distribution in a pipe crawling robot. *IEEE/ASME Trans. on Mechatronics* 6 (1).
- Gardner, J.(1992). Efficient computation of force distributions for walking machines on rough terrain. *Robotica* 10 (5), 42 -433.
- Golubev, Y., Kartashov, V. & Schneider, A.(1979). 2 *All-Union conference "Beomechanics Problems"*, chap. Force distribution in legs of legged robot, pp. 152-153. Riga, (in Russian): "Zinatne" Press.
- Golubev, Y. & Korianov, V.(2003). Motion design for six-legged robot overcoming the vertical column by means of friction forces. In *Int. Conf. on Climbing and Walking Robots, CLAWAR'03*, pp. 609-616. Catania, Italy.
- Gorinevsky, D., Formalsky, A. & Schneider, A.(1997). *Force Control of Robotics Systems*, p. 350. N.Y.: CRC Press.
- Gorinevsky, D., Lensky, A. & Schneider, A.(1986). Dependence of the natural frequencies of a force-moment sensor on the design parameters. *Vestnik of Moscow University* 41 (3), 10-16.
- Gorinevsky, D. & Shneider, A.(1987). Dynamics of small motion of a walking robot when there is feedback with respect to the support reactions. *Mechanics of Solids* 22 (6), 37-46.
- Gorinevsky, D. & Shneider, A.(1990). Force control in locomotion of legged vehicle over rigid and soft surfaces. *Int. J. Robot. Res.* 9 (2), 4-23.
- Green, A. & Zerna, W.(1968). *Theoretical Elasticity*, chap. 457. Oxford: Clarendon Press.
- Gurfinkel, V. & Fomin, S.(1973). Biomechanical principles of constructing artificial walking systems. In *Proc. of the First CISM-IFTOMM Sympos., ROMANSY'73*, pp. 28-39. Udine, Italy.
- Gurfinkel, V., Gurfinkel, E., Devjanin, E., Efremov, E., Zhicharev, D., Lensky, A., Schneider, A. & Shtilman, L.(1982). "Investigation of Robotics", chap. Six-legged walking model of vehicle with supervisory control, pp. 98-147. Moscow, (in Russian): Press "Nauka".
- Gurfinkel, V., Gurfinkel, E., Schneider, A., Devjanin, E., Lensky, A. & Shtilman, L.(1981). Walking robot with supervisory control. *Mechanism and Machine Theory* 16, 31-36.
- Halme, A., Hartikainen, K. & Kärkkäinen, K.(1994). Terrain adaptive motion and free gait of a six-legged walking machine. *Control Eng. Practice* 2 (2), 273-279.
- Hirose, S.(1984). A study of the design and control of a quadruped walking vehicle. *Intern. J. of Robotics Research* 3 (2), 113-133.
- Hirose, S., Nacabuko, A. & Toyama, R.(1991). Machine that can walk and climb on floors, walls, and ceilings. In *ICAR*. Pisa, Italy.
- Hirose, S. & Umetani, Y.(1980). The basic motion regulation system for a quadruped walking machine. In *ASME, Design Engineering Technical Conference*. Los Angeles, USA.

- Ignatyev, M., F.M.Kulakov & Mihaeilov, A.(1974). Algorithms for control of robot-manipulators. *Mechanics of Machines* 46, "Nauka", Moscow, (in Russian).
- Inagaki, K. & Kobayashi, H.(1993). A gait for quadruped walking machine. In *Inter. Conference on Intelligent Robots and Systems*, vol. 1. Yokohama, Japan.
- Ishino, Y., Narusa, T., Sawano, T. & Honma, N.(1983). *icar*, chap. Walking robot for underwater construction. Tokyo.
- Jiang, W., Liu, A. & Howar, D.(2004). Optimisation of legged robot locomotion by control of foot force distribution. *Transactions of the Institute of Measurement and Control* 26 (4), 311-323.
- Kaneko, M., Mizuno, A. & Harada, K.(2002). Torque distribution for achieving a hugging walk. In *Proc. of IEEE/RSJ, Int. Conf. on Intelligent Robots and Systems*, pp. 2613- 2618. Lausanne, Switzerland.
- Kaneko, M., Tanie, K. & Than, M. M.(1988). A control algorithm for hexapod walking machine over soft ground. *IEEE J. of Robot. and Automat.* 4 (3), 294-302.
- Kemurdjian, A.(1995). Planet rover today. In *Proc. of V11 Intern. Conference on Advanced Robotics, ICAR '95*, vol. 1, pp. 293-299. Spain.
- Kirschner, F. & Spennberg, D.(2001). *CLAWAR*, chap. Omni-Directional walking in multi-pod robot based on feedback driven oscillators and local reflex mechanisms.
- Klein, C. & Briggs, R.(1980). Use of active compliance in the control of legged vehicles. *IEEE Trans. Sys. Man Cybernet* SMC-10 (7), 393-400.
- Klein, C. & Kittivacharapong, S.(1990). Optimal force distribution for the legs of a walking machine with friction cone. *IEEE Trans. on Robotics and Automation* 6 (1), 73-85.
- Klein, C. & Wahavisan, W.(1984). Use of a multiprocessor for control of a robotic system. *Int. J. Robot. Res.* 1 (2), 45-59.
- Kumar, V. & Waldron, K.(1988). Force distribution in closed kinematics chains. *IEEE J. of Robotics and Automation* 4 (6), 659-663.
- Kumar, V. & Waldron, K.(1990). Force distribution in walking vehicles. *ASME J. of Mechanical Design* 112 (Mach.), 90-99.
- Lehtinen, H.(1994). Force based motion control of a walking machine. PhD thesis, Technical Research Centre, Finland, ESPOO.
- Marhef, D. & Orin, D.(1998). Quadratic optimization of force distribution in walking machines. In *IEEE of IEEE Intern.Conf. on Robotic and Automation*, pp. 477-483.
- Marsh, P.(1985). *Robots*. London: Salamander Book Limited.
- McGhee, R.(1976). *Neural Control of Locomotion*, chap. Robot locomotion, pp. 237-264.
- McGhee, R.(1977). Control of legged locomotion systems. In *Proc. 18th Automatic Control Conf.*, pp. 205-215. San Francisco,.
- McGhee, R. & Iswandhi, G.(1979). Adaptive locomotion of multi-legged robot over rough terrain. *IEEE Trans. on System Man, and Cybernetics* SMC-9 (4), 176-182.
- McGhee, R., Olson, K. & Briggs, R.(1980). *Proc. of 1980 Automotive Engineering Congress. Detroit, Michigan*, chap. Electronic Coordination of Joint Motion for Terrain-Adaptive Robot Vehicles, pp. 1-7. N.Y.: Pergamon Press.
- Miura, H., Shimoyama, I., Mitsuishi, M. & Kimura, H.(1985). *Dynamical walk of quadruped robot..* MIT Press.
- Mocci, U., Peternella, M. & Salinari, S.(1973). chap. Experiences with six-legged walking machines with fixed gait. Belgrade: Advances in External Control of Human Extremities.
- Morrison, R.(1968). *Cornell Aeronautical Lab/ ISTVS Off-Road Mobility Research Symp.*, chap. Iron Mule Train. Washington DC, USA.

- Mosher, R.(1968). Test and evaluation of a versatile walking truck. In *Proc. of Off-Read Mobility Research Symp. Int. Society for Terrain Vehicle Systems*, pp. 359-379. Washington DC, USA.
- Nagy, P., Desa, S. & Whittaker, W.(1992). Predicting force redistribution on walking robots for reliable locomotion: Modelling and experiments". In *ASME Mechanisms Conference, September*, pp. 13-16.
- Okhotsimski, D. & Platonov, A.(1973). Control algorithm of the walking climbing over obstacles. In *Proc. of the Third Intern. Joint Conference on Artificial Intelligence*. Stanford, California.
- Okhotsimski, D. & Platonov, A.(1976). Walker's motion control. In *Proc. of CISM-IFTOMM Symp. "ROMANSY-76"*. Warsaw, Poland.
- Okhotsimski, D., Platonov, A., Gerken-Gubanov, G., Kuznetsov, V., Devjanin, E., Lensky, A., Gurfinkel, E. & Schneider, A.(1978). Integration walking robot simulation and modeling. In *7th Congress IFAC,,*, vol. 2, pp. 917-924. Helsinki: Pergamon Press.
- Okhotsimsky, D. & Golubev, Y.(1984). *Motion mechanics and control of motion on an automated walking vehicle*, p. 312. Moscow, (in Russian): Publishing House "Nauka".
- Okhotsimsky, D., Platonov, A., Kiril'chenko, A., Lapshin, V. & Tolstousova, V.(1992). Walking machines. *Advances in Mechanics. Keldysh Institute of Applied Mathematics, Moscow* 15 (1-2), 39-70.
- Orin, D. & Oh, S.(1981). Control of force distribution in robotic mechanisms containing close kinematics chains. *J. Dyn.Syst. Meas. Contr.* 102, 134-141.
- Ozguner, F., Tsai, S. & McGhee, R.(1984). An approach to the use of terrain-preview information in rough terrain locomotion by a hexapod walking machine. *Int. J. of Robot. Research* 3 (2), 134-146.
- Peternella, M. & Salinari, S.(1973). Simulation by digital computer of walking machine control system. In *Proc. of V IFAC Symp. on Automatic Control in Space*. Genoa, Italy.
- Pfeiffer, F., Eltze, J. & Weidermann, H.(1994). The tum-walking machine. In *ISRAM'94*, pp. 1-20. Wailea, Maui, Hawaii, USA.
- Pfeiffer, F., Eltze, J. & Weidermann, H.(1995). Six-legged technical walking considering biological principles. *Robotics and Automation* pp. 22-23.
- Raibert, M.(1986). *Legged Robots that Balance*, p. 227. Cambridge, Mass.: MIT Press.
- Roßman, T. & Pfeiffer, F.(1998). Control of pipe crawling robot. In *Proc. Euromech 375. Biology an Technology of Walking*, pp. 133-140. Munich, Germany.
- Rosheim, M.(1994). *Robot Evaluation. The Development of Anthrobotics*. John Wiley and Sons, Inc.
- Roston, G.(1994). Lunar rovers for scientific and entertainment missions. *Acta Astronautica* 25, 397-406.
- Rygg, L.(1893). Mechanical horse. patented no 491,927, feb. 114, 1893. *Tech. Rep.*
- Schmucker, U.(2002). *Schwerpunktprogramm "Autonomes Laufen". Abschlußbericht*, chap. Multisensorielle Verfahren zur Bewegungssteuerung sechsbeiniger Schreitroboter, p. 88. Magdeburg: IFF.
- Schmucker, U., Schneider, A. & Ihme, T.(1996). Hexagonal walking vehicle with force sensing capability. In *Proc. ISMCR'96*, pp. 354-359. Brussels.
- Schmucker, U., Schneider, A. & Ihme, T.(1997). Force control for legged robots. In *ICAR'97 - 8th Int. Conf. on Advanced Robotics. Workshop "New Approaches on Dynamic Walking and Climbing Machines"*, pp. 38-43. Monterey, USA.

- Schmucker, U., Schneider, A., Rusin, V. & Zavgorodniy, Y.(2002). Control signals generation for limbs and body of walking robots. In *Int. Conf. on Climbing and Walking Robots, CLAWAR'02*, pp. 495–500. Paris.
- Schneider, A., Gurfinkel, E., Kanaev, E. & Ostapchuk, V.(1974). *Report No. 5, General and Molecular Physics Series*, chap. A system for controlling the extremities of artificial walking apparatus., pp. 64–80. Moscow: Physico-Technical Institute Moscow.
- Schneider, A., Zeidis, I. & Zimmermann, K.(2004). Stability of a “manipulator-drill” system with force control and time delay. *Technische Mechanik* 24 (1), 51–60.
- Shigley, J.(1961). The mechanics of walking vehicles. In *Proc. 1st Int. Conf. on Mechanics of Soil–Vehicle Systems*. Turin.
- Shik, M. & Orlovsky, G.(1976). Neurophysiology of locomotor automatism. *Physiol. Revs.* 56 (3), 456–501.
- Simmons, R. & Krotkov, E.(1991). *IEEE Inter.Conf. of Robotics and Automation*, chap. An integrated walking sytem for the ambler planetary rover. Sacramento, CA.
- Song, S.-M. & Waldron, K.(1989). *Machines that walk: The adaptive suspension vehicle*, p. 314. The MIT Press.
- Steuer, J. & Pfeiffer, F.(1998). Autonomous control of a six-legged walking machine. In *Proc. Euromech 375 .Biology and Technology of Walking*, pp. 141–148. Munick, Germany.
- Sukhatme, G. & Bekey, G.(1995). An evaluation methodology for autonomous mobile robots for planetary exploration. In *First ECPD Inter. Conference on Advanced Robotics and Intelligent Automation*, pp. 558–563. Greece.
- Thring, M.(1983). *Robots and Telechairs*. New York: Ellis Horwood, Limited.
- Todd, D.(1985). *Walking Machines–An Introduction to Legged Robots*. Essex, England: Anchor Press.
- Tomovic, R. & R, B. M.(1966). A finite state approach to the synthesis of bioengineering control systems. *IEEE Trans. on Human Factors in Electronics* HFE-7, 65–69.
- Umetani, Y., Omichi, T., Ibe, T., Hirose, S., Sirozi, K. & Ishibahi, A.(1985). Four legged walking robot. *Robot* (47).
- Umnov, N.(1981). Theory and methods of constructing efficient drives of multi-legged walking machines. PhD thesis, Inst. Mech. Eng., AN USSSR, Moscow, (in Russian).
- Vukobratovic, M., Borovac, B., Surla, D. & Stokic, D.(1990). *Biped Locomotion*. Heidelberg, Berlin, New York: Springer-Verlag.
- Waldron, K.(1986). Force and motion management in legged locomotion. *IEEE J. of Robot. Automat.* 2 (4), 214–220.
- Whitney, D.(1969). Resolved motion rate control of manipulators and human prostheses. *IEEE Trans. Man-Mach.Syst.* 10, 47–53.





## **Mobile Robotics, Moving Intelligence**

Edited by Jonas Buchli

ISBN 3-86611-284-X

Hard cover, 586 pages

**Publisher** Pro Literatur Verlag, Germany / ARS, Austria

**Published online** 01, December, 2006

**Published in print edition** December, 2006

This book covers many aspects of the exciting research in mobile robotics. It deals with different aspects of the control problem, especially also under uncertainty and faults. Mechanical design issues are discussed along with new sensor and actuator concepts. Games like soccer are a good example which comprise many of the aforementioned challenges in a single comprehensive and in the same time entertaining framework. Thus, the book comprises contributions dealing with aspects of the Robotcup competition. The reader will get a feel how the problems cover virtually all engineering disciplines ranging from theoretical research to very application specific work. In addition interesting problems for physics and mathematics arises out of such research. We hope this book will be an inspiring source of knowledge and ideas, stimulating further research in this exciting field. The promises and possible benefits of such efforts are manifold, they range from new transportation systems, intelligent cars to flexible assistants in factories and construction sites, over service robot which assist and support us in daily live, all the way to the possibility for efficient help for impaired and advances in prosthetics.

### **How to reference**

In order to correctly reference this scholarly work, feel free to copy and paste the following:

A. Schneider and U. Schmucker (2006). Force Sensing for Multi-Legged Walking Robots: Theory and Experiments Part 1: Overview and Force Sensing, Mobile Robotics, Moving Intelligence, Jonas Buchli (Ed.), ISBN: 3-86611-284-X, InTech, Available from:

[http://www.intechopen.com/books/mobile\\_robotics\\_moving\\_intelligence/force\\_sensing\\_for\\_multi-legged\\_walking\\_robots\\_\\_theory\\_and\\_experiments\\_part\\_1\\_\\_overview\\_and\\_force\\_sen](http://www.intechopen.com/books/mobile_robotics_moving_intelligence/force_sensing_for_multi-legged_walking_robots__theory_and_experiments_part_1__overview_and_force_sen)

# **INTECH**

open science | open minds

### **InTech Europe**

University Campus STeP Ri  
Slavka Krautzeka 83/A  
51000 Rijeka, Croatia  
Phone: +385 (51) 770 447  
Fax: +385 (51) 686 166  
[www.intechopen.com](http://www.intechopen.com)

### **InTech China**

Unit 405, Office Block, Hotel Equatorial Shanghai  
No.65, Yan An Road (West), Shanghai, 200040, China  
中国上海市延安西路65号上海国际贵都大饭店办公楼405单元  
Phone: +86-21-62489820  
Fax: +86-21-62489821