

# Interference Rejection in Digital Wireless Communications

© Andy Zito Image Bank

## An Overview of the Advances in Single-Channel Adaptive Filtering Techniques

The growth in wireless communications necessitates more efficient utilization of spectrum. The increased sharing of spectrum translates into a higher likelihood of users interfering with one another. Interference-rejection techniques allow a high capacity of users within available spectrum. This overview comprises a literature review of published papers pertaining to single-channel adaptive interference rejection in digital wireless dating primarily from 1980 to the present. Though previous overviews are referenced and summarized, the focus is on advances not covered by previous overviews (consequently, some papers are included that predate 1980 because they are not covered in previous overviews).

The organizational chart shown in Fig. 1 outlines the types of techniques covered by this article. For the benefit of the nonspecialist, tutorial material begins most sections to introduce each category. Following the tutorial material, each section contains a summary of recent advances and contributions to the particular area. For cursory reading, one can focus on the first few paragraphs to gain insight into the general technique and skip the subsequent

summary of particular contributions. To assist in the reading of the material, Table 1 furnishes a list of abbreviations used throughout this article.

## Importance of Interference Rejection

Interference rejection is important for several reasons. Cellular capacity is inherently interference limited, particularly by co-channel interference (CCI) and adjacent-channel interference (ACI). One solution to combat CCI and ACI is to split cells and decrease power, but cell-splitting is expensive. Interference-rejection techniques often represent a less expensive alternative to cell-splitting.

In addition, as newer communication technologies supersede older technologies, interference-rejection techniques are important in helping to facilitate compatibility during transitions between the old and new technologies. Several examples illustrate the need for compatibility: co-utilization of the existing cellular band with new narrowband code-division multiple access (CDMA) and time-division multiple access (TDMA) digital cellular signals, broadband CDMA overlaying advanced mobile phone system (AMPS) signals in the cellular bands, co-utilization of the new personal communication system (PCS) band (1.8-2.2 GHz) with existing microwave systems, the addition of a vast number of new low-earth-orbiting (LEO) satellites with overlapping

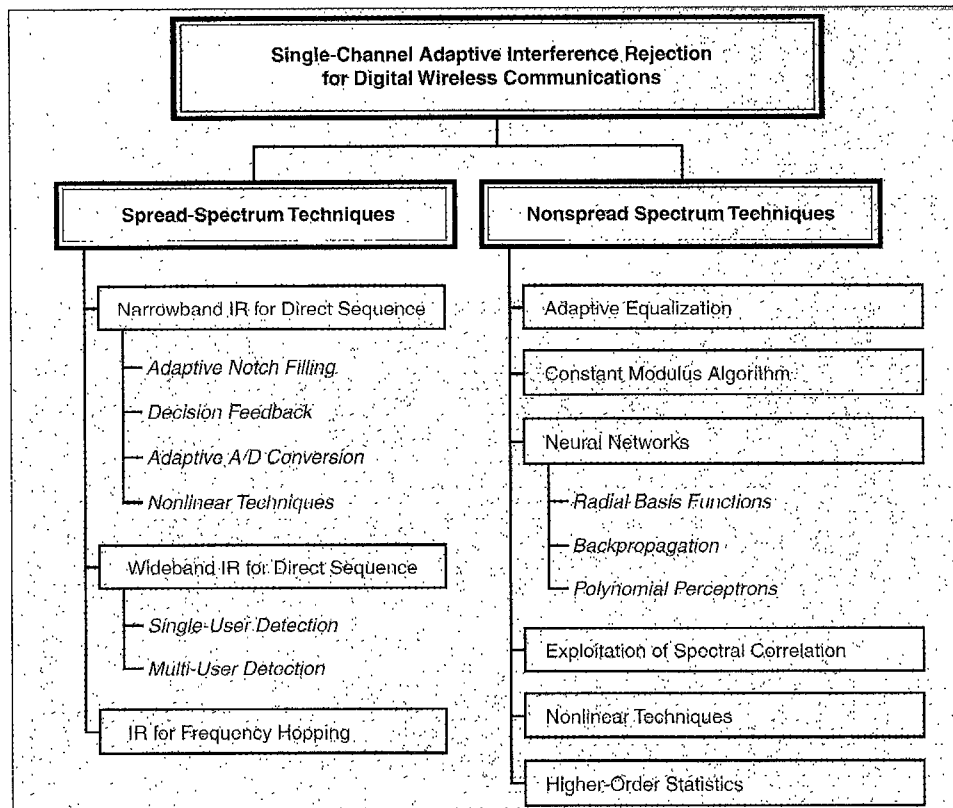

1. Organizational chart of single-channel adaptive interference-rejection techniques for wireless digital communications.

footprints with older satellites, and accommodation of high-definition television (HDTV) transmissions within the current TV band.

The CDMA overlay or coexistence with AMPS results in interference—the key problem in making viable this new digital cellular format. Schilling, Lomp, and Garodnick [147] present a broadband CDMA (B-CDMA) scheme that will overlay the existing cellular telephone spectrum (825-894 MHz). The overlay will provide additional capacity to the network while allowing high-quality voice and high-speed data services to coexist with the existing cellular services (AMPS and IS-54). The absence of mutual interference to and from the B-CDMA overlay will be accomplished by using an adaptive filter. CDMA based on IS-95, even though it is not an overlay system, must also contend with AMPS interference from other cells.

In satellite-based PCSs, geostationary satellites can interfere with each other as well as with LEO satellites, which limits capacity. This issue is especially relevant because of the large number of LEO satellites proposed for worldwide cellular and information networks. An informative overview of satellite interference is found in the work of Kennedy and Koh [86]. Their paper discusses the background and relevance of the problem of frequency-reuse interference in TDMA/QPSK satellite systems and suggests techniques to alleviate interference effects.

Global positioning system (GPS) applications potentially will experience a mixture of both narrowband and wideband interferences. For example, commercial aircraft are suscepti-

ble to having their GPS receivers jammed (intentionally or unintentionally). Sources of unintentional interference range from RF transmitters onboard the aircraft or on nearby aircraft to other RF transmitters such as TV and FM stations and PCSs using mobile satellite services. Onboard RF transmitters (e.g., VHF radio and satellite communications equipment) comprise the most immediate and highest degree of threat to GPS receivers [30].

The military applications of interference rejection are numerous. The most obvious application is in mitigating the effects of intentional jamming. A not so obvious application is the mitigation of self-jamming from harmonics produced by operating transmitters and receivers in close proximity to each other [158]. In addition, in reconnaissance applications, a stand-off receiver covering a

wide geographical region is subject to interference from nonintelligence-bearing signals operating in the same band.

## Adaptive Interference Rejection

Interference-rejection techniques often need to be adaptive because of the dynamic or changing nature of interference and the channel. In this article, methods of interference rejection are viewed as adaptive filtering techniques. The term *filter* is often used to describe a device (in the form of software or hardware) that is applied to a set of noisy data to extract information about a prescribed quantity of interest. The design of an optimum filter requires *a priori* information about the statistics of the data to be processed. Where complete knowledge of the relevant signal characteristics is not available, an adaptive filter is needed, meaning that the filter is a self-designing device that relies on a recursive algorithm to converge to the optimum solution in some statistical sense. A useful approach to the filter-optimization problem is to minimize the mean-square value of the error signal, which is defined as the difference between some desired response and the actual filter output [67]. A general block diagram of an adaptive filter applied to the communications problem is given in Fig. 2.

## Single-Channel versus Multichannel

This article focuses on single-channel adaptive filtering techniques for interference rejection (that is, techniques employing one antenna) as opposed to multichannel techniques

**Table 1. Abbreviations Used Throughout This Article**

A/D	Analog-to-Digital	IMM	Interacting Multiple Model
ACI	Adjacent-Channel Interference	IPA	Infinitesimal Perturbation Analysis
ADC	Analog-to-Digital Converter	IS-54	Intermediate Standard - 54
ADF	Adaptive Digital Filter	ISI	Intersymbol Interference
AEQ	Adaptive Linear Equalizer	J/S	Jammer-to-Signal Ratio
AGC	Automatic gain control	LCCM	Linearly Constrained Constant Modulus
AIC	Adaptive Interference Canceler	LEO	Low-Earth Orbiting
ALE	Adaptive Line Enhancer	LFSE	Linear Fractionally Spaced Equalizer
AM	Amplitude Modulation	LMS	Least-Mean-Square
AMPS	Advanced Mobile Phone System	LO	Locally Optimal
ANC	Adaptive Nonlinear Converter	LPP	Lattice Polynomial Perceptron
ANLE	Adaptive Nonlinear Equalizer	LPF	Lowpass Filter
AR	Autoregressive	LS	Least Squares
ATF	Adaptive Time-Frequency	LTE	Linear Transversal Equalizer
AWGN	Additive White Gaussian Noise	MA	Multiple Access
B-CDMA	Broadband CDMA	MAI	Multiple Access Interference
BER	Bit Error Rate	MF	Misadjustment Filter
BPF	Bandpass Filter	ML	Maximum Likelihood
CCI	Co-Channel Interference	MLSE	Maximum Likelihood Sequence Estimation
CDMA	Code Division Multiple Access	MMSE	Minimum Mean Squared Error
CMA	Constant Modulus Algorithm	M-QAM	Multilevel QAM
CNNDF	Complex Neural-Network-Based Adaptive DF Filter	NBI	Narrowband Interference
COF	Code-Orthogonalizing Filter	NED	Normalized Envelope Detection
CPM	Continuous Phase Modulation	NTSC	National Television System Committee
CW	Continuous Wave	OS	Order Statistics
DEDS	Discrete Event Dynamic System	OTDR	Optimal Time-Dependent Receiver
DF	Decision Feedback	PCS	Personal Communications Systems
DFE	Decision Feedback Equalizer	PSK	Phase Shift Keying
DPSK	Differential Phase-Shift Keying	PN	Pseudo-Noise
DS	Direct Sequence	PP	Polynomial Perceptron
DSSS	DS Spread Spectrum	QAM	Quadrature AM
FDM	Frequency-Division Multiplexing	QPRS	Quadrature Partial Response Signaling
FDMA	Frequency-Division Multiple Access	QPSK	Quadrature PSK
FER	Frame Error Rate	RBF	Radial Basis Function
FFH	Fast Frequency Hopping	RLS	Recursive Least Squares
FH	Frequency Hopping	SDR	Symmetric Dimension Reduction
FIMM	Fast Interacting Multiple Model	SIR	Signal-to-Interference Ratio
FIR	Finite Impulse Response	SINR	Signal-to-Interference Noise Ratio
FLA	Fast Learning Algorithm	SNR	Signal-to-Noise Ratio
FM	Frequency Modulation	SOI	Signal-of-Interest
FRESH	FREquency Shift	SNOI	Signal-Not-of-Interest
FSBLP	Fractionally Spaced Bilinear Perceptron	SOM	Self-Organizing Feature Map
FSDFMLP	Fractionally Spaced DF Multilayer Perceptron	SPREIS	Spectral Redundancy Exploiting Interference Suppressor
FSE	Fractionally-Spaced Equalizer	SSMA	Spread Spectrum Multiple Access
FSRPP	Fractionally Spaced Recursive Polynomial Perceptron	SSMF	Spread Spectrum Matched Filter
FSK	Frequency Shift Keying	SS	Spread Spectrum
GFC	Gradient-Search Fast Converging	TDAF	Time-Dependent Adaptive Filter Tapped-Delay Line
GLRT	Generalized Likelihood-Ratio Test	TDMA	Time-Division Multiple Access
GMSK	Gaussian Minimum Shift Keying	TFD	Time-Frequency Distributions
GPS	Global Positioning System	THE	Threshold Excision
HDTV	High-Definition Television	VSIE	Vector-Space Interference Excision
HOS	Higher-Order Statistics	WF	Wiener Filter
ICE	Interference-Canceling Equalizer	WHT	Walsh-Hadamard Transform

(which employ multiple antennas, such as arrays or cross-polarized antennas). Multiple antennas allow multichannel reception, where each channel carries a different version of the transmitted signal. The differences in the received versions of the signal at each antenna can be used to enhance and detect the desired signal. With single-channel reception, only one version of the transmitted signal is received, usually by only one antenna or sensor.

The military has always been interested in single-channel techniques because they have been generally cheaper, less complex, smaller in size, and more suited to rugged military applications than multichannel techniques. Along the same lines, the commercial wireless community will likely favor interference-rejection techniques that are inexpensive and simple to implement.

## Spread Spectrum versus Nonspread Spectrum

As shown in Fig. 1, this article divides interference-rejection techniques for digital modulation into spread-spectrum (SS) techniques and non-SS techniques (loosely, techniques for wideband signals and techniques for narrowband signals). This categorization is made for several reasons relating to the nature of the interference to be rejected or mitigated. For example, the case of narrowband interference (NBI) on a SS signal leads to a class of different techniques that would not be applicable to the case of NBI co-channeled with a narrowband signal. In SS systems employing CDMA, the users share the same frequency and, at the same time, interfere with each other by design (users are separated by code). Though high levels of interference exist, the interfering users have similar statistics, leading to another class of techniques. One can also take advantage of unique SS properties such as code repetition to reject interference and increase the number of users that can be supported in a given band.

## Spread-Spectrum Techniques

Spread spectrum, by its very nature, is an interference-tolerant modulation. However, there are situations where the processing gain is inadequate and interference-rejection techniques must be employed. This is especially true for direct-sequence SS (DSSS), which suffers from the near-far problem. For this article, SS categories include direct sequence (DS), CDMA, and frequency hopping (FH).

Several tutorial papers have been published on interference rejection in SS, of which Milstein's paper [108] is of

particular interest. Milstein discusses in depth two classes of rejection schemes (both of which implement an adaptive notch filter): 1) those based upon least-mean-square (LMS) estimation techniques, and 2) those based upon transform-domain processing structures. The improvement achieved by these techniques is subject to the constraint that the interference be relatively narrowband with respect to the DS waveform. The present overview focuses on advances in interference rejection not covered by the 1988 Milstein paper. Kohno [87] provides another overview of classic solutions and promising techniques being studied in Japan and, in particular, describes a temporal-domain approach where an adaptive digital filter (ADF) is employed to adaptively identify the time-varying response of the CCI in a DSSS multiple access (MA) system without excessive noise enhancement.

Poor and Rusch [131, 144] give an overview of NBI suppression in SS CDMA. They categorize CDMA interference suppression by linear techniques, nonlinear estimation techniques, and multiuser detection techniques. Using Milstein's 1988 paper, they describe linear techniques that include estimator/subtractor methods that perform time-domain notch filtering and transform-domain methods that operate to block (or suppress) narrowband energy in the frequency domain. In addition, Poor [132] reviews the adaptive filtering techniques for mitigation of MA and NBIs that arise in MA communications applications.

With particular application to CDMA, Duel-Hallen, Holtzman, and Zvonar [41] provide a very useful overview of multiuser detection to mitigate MA interference (MAI) (see the section on adaptive multiuser detection). They describe the concept of multiuser detection and typical techniques that are used, considering both coherent and noncoherent detection. Verdú [164] also gives a survey of various techniques proposed for adaptive multiuser detection.

## Narrowband Interference Rejection for Direct Sequence

Interference-rejection techniques for DSSS systems are numerous. In particular, much literature exists on the adaptive notch filter as it relates to rejecting NBI on a wideband DSSS signal. Decision-directed adaptive filtering is another well-established technique for interference rejection. Other techniques for narrowband DSSS include adaptive analog-to-digital (A/D) conversion and nonlinear adaptive filtering. The following discussion focuses on innovative techniques developed since the 1988 tutorial paper by Milstein [108].

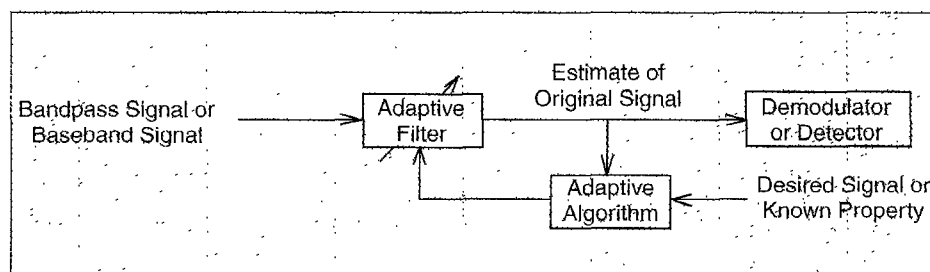

2. A typical adaptive filter applied to the communications problem.

### Adaptive Notch Filtering

The basic idea in employing an adaptive notch filter is to notch out or flatten the spectrum of the interference. SS tends to have a flat and wide spectrum and is affected little by this process, while NBI is characterized by spikes in the spectrum. The adaptive notch

filter places notches at the location of the NBI to bring the interference level down to the level of the SS signal. At least two main approaches exist for creating an adaptive notch filter—1) rejection schemes based on estimation-type filters (using adaptive techniques such as LMS) and 2) rejection schemes based on transform-domain processing structures.

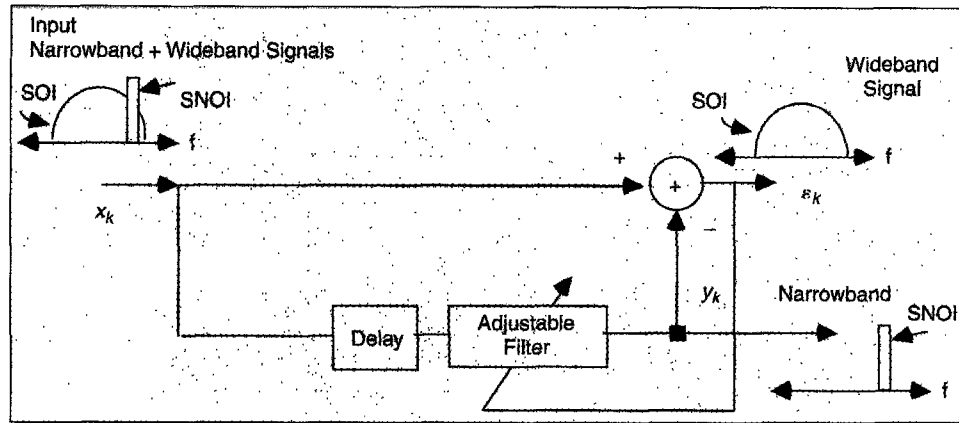

3. An adaptive notch filter or whitening filter.

### Prediction/estimation-type filters.

Estimation-type filters (sometimes called prediction-type filters or whitening filters) can be viewed as performing a whitening (i.e., making the output samples uncorrelated) of the entire received signal. Usually the whitening process is implemented by an adaptive filter configured as a predictor of the narrowband signal. A tapped-delay line (TDL) can implement either a one-sided prediction filter (Wiener filter) or a two-sided filter (which is based on future values, as well as past values) to estimate the present. For a DS signal corrupted by noise and NBI, future values tend to be uncorrelated with past values for DS and noise since they are wideband processes. Other the other hand, the interference, being a narrowband process, exhibits correlation between the past values and future values. The interference can therefore be predicted from past values and subtracted from the input signal. The wideband SS signal would then appear at the error output of the adaptive filter. An example of this type of adaptive notch filtering is shown in Fig. 3 and is sometimes referred to as an adaptive line enhancer (ALE).

The filter weights are updated with some adaptive algorithms such as LMS estimation techniques. The LMS algorithm (complex) can be expressed in the form of three basic relations [67, 172]:

$$1. \text{ The filter output: } y_k = \mathbf{w}_k^H \mathbf{x}_k \quad (1a)$$

$$2. \text{ The adaptation error: } \varepsilon_k = d_k - y_k \quad (1b)$$

$$3. \text{ The tap weight adaptation: } \mathbf{w}_{k+1} = \mathbf{w}_k + \mu \mathbf{x}_k \varepsilon_k^* \quad (1c)$$

where  $k$  denotes the discrete time,  $y_k$  is the filter output,  $\mathbf{w}_k$  is the tap-weight vector,  $\mathbf{x}_k$  is the tap-input vector,  $H$  indicates Hermitian transposition (i.e., conjugate transposition),  $\varepsilon_k$  is the estimation error,  $d_k$  is the desired response,  $\mu$  is the step-size parameter, and  $*$  denotes conjugation.

Doherty [31, 33] presents an enhancement of the whitening filter technique that adds constraints based on the known characteristics of the pseudo-noise (PN) SS sequence to enhance the detection capabilities diminished by interference excision. Operating without training bits, the constrained updating of the filter coefficients retains the

interference-rejection properties of the excision filter while decreasing the variance of the decision variable. The standard LS rejection filter adds distortion to the decision variable at the output of the despreading operation. Doherty [34, 36] describes a constrained LS technique that utilizes a constrained optimality criterion to enhance the detection capabilities of DSSS systems. Two transversal TDLs are operated simultaneously, one containing the received data and the other containing the constraint data, as one set of adaptive weights operates on both TDLs with the LMS algorithm as the update technique. The filter weights are updated with respect to both minimizing the mean-square output error and minimizing the constraint error, with two types of constraint conditions: a correlation-matching condition (which induces the filter to pass the chip sequence undistorted) and a minimum-filter-energy condition. Doherty [35] incorporates vector-space projection techniques to arrive at constraint surfaces used to suppress correlated interference.

Davis and Milstein [29] investigate the NBI rejection capability of the fractionally spaced equalizer and describe an adaptive TDL equalizer that operates in a DS-CDMA receiver, where the taps are adapted to minimize the mean-square error (MSE) of each chip. The overall effect of such equalization is to whiten the noise (in this case, MAI). This structure can be applied to reject NBI, and with sufficiently small tap spacing, it can reject NBI before the jammer is aliased at the chip rate. The technique is also compared to previously published methods of NBI rejection.

Krieger [88] proposes a constrained optimization criterion to drive an adaptive algorithm that operates on the output of a DSSS demodulator. Based on maximum signal-to-interference noise ratio (SINR), the adaptive algorithm estimates the generalized smallest and largest eigenvalues and their corresponding eigenvectors for positive definite matrices. Haimovich and Vadhri [66] state that while the energy of the SS signal is distributed across all the eigenvalues of the data correlation matrix, the energy of the interference is concentrated in a few large eigenvalues. The corresponding eigenvectors span the same signal subspace as the interference. Their method of rejecting NBI in PN SS systems derives an error-prediction filter with the additional constraint of orthogonality to these eigenvectors.

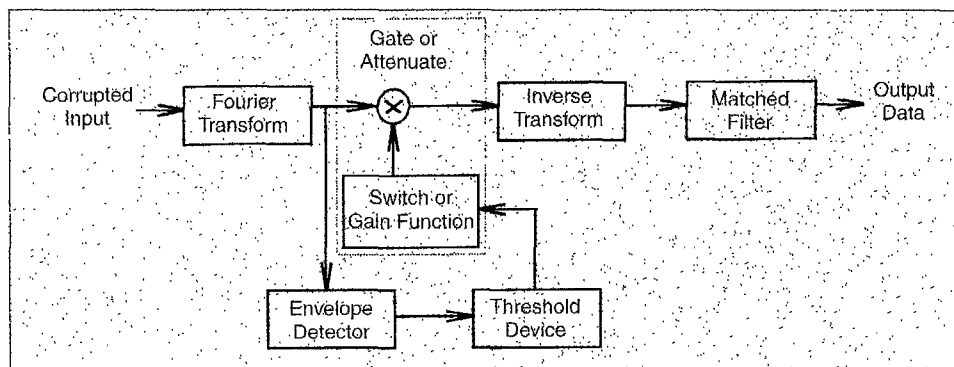

4. Block diagram of an adaptive transform-domain processing receiver, based on [108].

Stojanovic, Dukic, and Stojanovic [152] use LMS estimation to determine the tap weights of two-sided adaptive transversal filters so as to minimize the receiver output MSE caused by the presence of NBI and additive white Gaussian noise (AWGN). The results obtained show a significant reduction of the error rate in comparison to previously published results. Theodoridis et al. [157] propose a block least-squares (LS) order-recursive algorithm for finite impulse response (FIR) filters with linear phase to design an FIR whitening filter for NBI rejection in PN SS systems. Simulations show 4-5 dB improvement in the output signal-to-noise ratio (SNR) over previously proposed schemes.

Several researchers have analyzed the impact of adaptive algorithms on performance. Bershad [16] investigates the effects of the LMS ALE weight misadjustment errors on the bit error rate (BER) for a DSSS binary communication system in the presence of strong NBI. The converged ALE weights are modeled as the parallel connection of a deterministic FIR filter and a random FIR filter. The statistics of the random filter are derived, assuming the output of the random filter to be primarily due to the jammer convolved with random filter weights, yielding a non-Gaussian output that causes significant error-rate degradation in comparison to a Gaussian model.

Lee and Lee [92] suggest a gradient-search fast converging algorithm (GFC). For the case of a sudden parameter jump or new interference, the transient behavior of the receiver using a GFC adaptive filter is investigated and compared with that of receivers using a LMS or a lattice adaptive filter. They maintain that the GFC is superior for suppressing irregular hostile jamming in DSSS. For better stability, He, Lei, Das, and Saulnier [69] discuss the modified LMS algorithm for transversal filter structures and lattice filter structures, comparing their BER performance and convergence characteristics.

Mammela [103] simulates the performance of optimal and adaptive interference suppression filters for DSSS systems. The simulations include the linear M-step prediction and interpolation filters and some of the best-known iterative and time-recursive algorithms (LMS, Burg, and Kalman algorithms). Mammela demonstrates that linear filters work well if the interference bandwidth is a small fraction of the signal bandwidth, and he shows that linear interpolation filters work better than prediction filters.

Iltis [81] proposes a receiver based on the generalized likelihood-ratio test (GLRT) where the interferer is modeled as an  $N$ th order circular Gaussian autoregressive (AR) process and the multipath channel is represented by a TDL. He derives the maximum-likelihood (ML) joint estimator for the channel coefficients and interferer AR parameters. The GLRT receiver outperforms the trans-

versal equalizer-based receiver by 2-3 dB.

**Transform-domain processing structures.** Performing notch filtering in a manner quite different from estimation-type filters, transform-domain processing structures utilize, as a basic building block, a device that performs a real-time Fourier transform. An example of this technique is given in Fig. 4. The lower branch envelope detects the Fourier transformed output, and the output of the envelope detector is fed into a switch (or an attenuator) controlled by a threshold device. The upper branch passes the Fourier-transformed input directly to the multiplier. To implement the adaptive notch filter, the switch in the lower branch is forced to zero (or the attenuator is turned on) whenever the output of the envelope detector exceeds a predetermined level [108].

To suppress powerful NBI in a PN SS system, Guertin [64] develops vector-space interference excision (VSIE) methods that suppress the sidelobes of a sinusewave interferer, in addition to the central lobe, while removing little signal power. VSIE methods are compared to frequency-domain methods, such as threshold excision (THE), which are complicated by the distribution of some of the power in a narrow band in sidelobes lying outside the original bandwidth. Guertin finds that SNR after VSIE is as much as 8 dB better than the SNR after THE.

Dominique and Petrus [37] excise NBI from a DSSS signal by making use of the spectral redundancy between the sidebands of the PN-BPSK signal. The SPectral Redundancy Exploiting Interference Suppressor (SPREIS) uses this redundancy to obtain a better estimate of the spectral energy of the signal-of-interest (SOI), by replacing corrupted spectral estimates with uncorrupted and correlated estimates. They show improved performance over the THE with a small increase in computational complexity.

Gevorgiz, Das, and Milstein [52] demonstrate the advantage of an intercept receiver that uses a transform-domain-processing filter and detects DS BPSK SS signals in the presence of NBI by employing adaptive NBI rejection techniques. The receiver uses one of two transform-domain-processing techniques. In the first technique, the NBI is detected and excised in the transform domain by using an adaptive notch filter. In the second technique, the interference is suppressed using soft-limiting in the transform domain.

Since transversal filter techniques achieve better performance when the reference signal is error-free, Lee and Essman [93] propose a scheme that utilizes a reference-signal generating loop (to generate a reference signal) and makes use of a scalar Wiener filtering technique in the Walsh-Hadamard transform (WHT) domain. The WHT is easy to implement since it requires only addition and subtraction. The scheme is not based on time-averaging methods, as in the lowpass filter (LPF) or chip-decision filter, so that a burst of errors due to the time-delayed reference signal is nearly absent and so that the chip error probability is significantly reduced. The WHT scalar filter prevents the weights from oscillating in steady-state when the additional reference signal is employed in interference suppression.

Ruth and Wickert [145] examine the performance of a DSSS receiver with a transform domain prefilter, as a function of noise power and jammer power. This time-varying interference-rejection filter introduces intersymbol interference (ISI), which must be then addressed. Ruth and Wickert also explore digital-design tradeoff issues such as the transform-domain excision filter bandwidth and window functions. Medley, Saulnier, and Das [106] extend transform-domain processing to include wavelets as the basis functions, in order to excise jamming signals from SS.

Tazebay and Akansu [156] propose a smart adaptive time-frequency (ATF) exciser that intelligently decides the domain of the excision by evaluating both the time- and frequency-domain properties of time-varying signals. The input signal is processed in the domain where the interference is more localized. For frequency-domain excision, adaptive sub-band transforms are utilized to track the spectral variations of the incoming signal. The ATF exciser performs well in NBI and time-localized wideband Gaussian interference, and it is very robust to variations of the input signal when compared to conventional techniques (such as transform-domain filtering).

Amin, Venkatesan, and Tyler [7] exploit the capability of time-frequency distributions (TFDs) to excise interference in SS. TFDs can properly represent single- as well as multiple-component signals in time and frequency. The instantaneous frequency from the TFD is used to construct an FIR filter that substantially reduces the interference power with minimum possible distortion of the desired signal.

With a CDMA overlay in mind, Kanterakis' [84] technique for narrowband/broadband frequency-selective limiting relies on setting the magnitude response of the received signal Fourier transform to a predetermined function while leaving the phase response unchanged. When the Fourier transform magnitude response of the signal is made constant over the entire signal spectrum, this nonlinear processor will operate as a whitening filter.

Wei, Zeidler, and Ku [170] examine the SS overlay problem assuming a realistic scenario that interferers are likely to occupy a significant portion of the CDMA bandwidth and have center frequencies that are offset from the carrier frequency of the CDMA signal. They derive an optimum suppression filter and demonstrate SNR improvement when

compared to the optimal Wiener filter. For suppression filters for CDMA overlay, Wang and Milstein [109, 168, 169] evaluate the average BER and investigate how the performance is influenced by parameters such as the number of taps of the suppression filter, the number of MA users, the ratio of NBI bandwidth to SS bandwidth, the interference power-to-signal power ratio, and so forth.

### Decision Feedback

An alternative to a transversal filter is a decision feedback (DF) filter. Decision feedback, or decision-directed, techniques use an adaptive filter to notch interference. Decisions (or "best guesses" of the signal state) are made at the output of the filter and then fed back to train the adaptive filter and/or be included in the filtering process. Variations of this technique exist where either the incoming signal is filtered and/or the estimation error is filtered. One version of such a filter is given in Fig. 5 and analyzed in [154]. In Fig. 5,  $r(t)$  is the received signal, which is coherently demodulated ( $\omega_0$  is the carrier frequency) and then integrated over the symbol interval ( $T_c$ ) and sampled.  $T$  is the delay,  $c_k$  is the  $k$ th chip of the PN sequence, and  $A$  is the amplitude of the received signal.

The rationale for using DF is to whiten just the noise and interference, necessitating some means of removing the desired signal. Since the output of the receiver is an estimate of the desired DS signal, this estimate can be used to generate a replica of the transmitted waveform, which can, in turn, be subtracted from the received signal. The possibility of error propagation exists, but this effect appears negligible in certain applications [108].

Detection in DSSS systems is often performed by correlating the received signal with the transmitter's spreading sequence. Pateros and Saulnier [125, 126] analyze the BER performance of an adaptive correlator, which has the same structure as a DF filter, that detects the incoming data and compensates for the channel. The adaptive correlator, using DF, is shown to be capable of removing relatively wideband interference in the transmission bandwidth. The method implements a linear minimum mean-square estimator of the transmitted data based on the received samples. The receiver structure (which requires a training sequence but does not require the spreading sequence) is capable of removing single tone interference, and its performance in multipath is shown to be comparable and even superior to that of a Rake receiver in some instances.

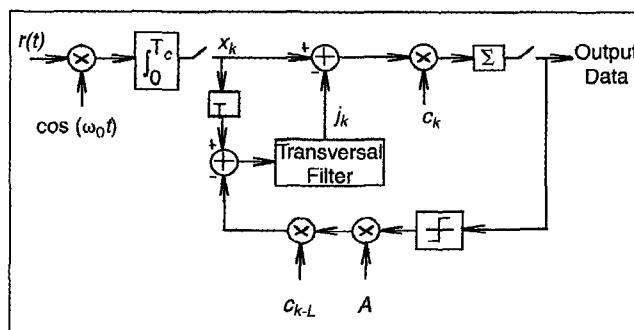

5. Decision feedback receiver, based on [154].

Ogawa, Sasase, and Mori [123] examine suppression of continuous wave (CW) interference and colored noise in a QPSK system using DF filters. They also [124] examine the performance of a differential phase-shift-keying (DPSK) DSSS receiver using DF filters in the presence of NBI and multipath. They find that the two-sided DF filter is superior for suppressing both interference and multipath in the SS system. Miyagi, Ogawa, Sasase, and Mori [112] analyze the performance of three types of quadrature partial response signaling (QPRS) systems using complex one-sided and two-sided transversal filters, with additional DF taps, in the presence of single CW interference and AWGN. They find that both DF filters suppress CW interference and also suppress noise. They also show that the duobinary system has the best performance of the three types of QPRS systems when the frequency of CW interference is low.

Dukic, Stojanovic, and Stojanovic [39, 42, 43, 44] combine two-sided transversal filters along with DF to combat NBI. Their receiver is made up of two branches: the conventional demodulator followed by a DF filter and, in an auxiliary branch, a demodulator with the carrier in quadrature followed by a two-sided adaptive transversal filter. The results show significant NBI rejection, with little dependence on the difference in frequencies of the desired and interfering carriers or on the interfering carrier level. The receiver is also robust to impulsive interference. Dobrosavljevic, Dukic, et al., [32] improve the receiver with two-stage DF filter techniques.

Shah and Saulnier [148] conclude that LMS adaptive filtering improves the probability-of-error performance of a DSSS system operating in the presence of stationary single-tone jammers. They also claim that, when compared with the no-feedback case, LMS adaptive systems with DF do not degrade probability-of-error performance; however, DF does not always appreciably improve system error rates either. Error rates for the systems with DF approach error rates for the no feedback case as the processing gain increases.

Other sections in this article contain examples of DF for interference rejection, such as DF used in CDMA adaptive multiuser detection, in adaptive equalization, in backpropagation neural networks, with radial basis functions (RBFs), in spectral correlation, and in novel techniques.

#### *Adaptive A/D Conversion*

Milstein's 1988 tutorial gives brief mention to another technique proposed by Amoroso [8, 10] and Pergal [129] for making the DS receiver more robust with respect to interference. Adaptive A/D conversion is a scheme using an A/D converter, in conjunction with a variable threshold, to retain those chips of the spreading sequence that, when added to a strong interfering signal, are still received with their correct polarity. The idea behind adaptive A/D conversion is that the bias introduced by a high-power narrowband interferer can be tracked and compensated for before entering the A/D converter. Equivalently, thresholds of the A/D converter can be changed to minimize the impact of the interference. Adaptive threshold A/D techniques exploit the statistical behavior of constant-envelope, angle-modulated, sinusoidal jammers to

enhance the effective processing gain of a PN receiver. For proper operation, it is necessary for this system to have both a large jammer/signal (J/S) ratio and a large ratio of interference power to noise power.

The A/D converter is distinguished from various forms of notch filtering in that the A/D converter performs well against CW even if the interference is frequency or phase modulated, as long as the amplitude of the CW mixed with the signal remains fairly constant. Pergal points out that A/D conversion gain depends only on the statistical distribution of the interfering signal (as opposed to notch filtering, which is spectrally dependent). Bricker [19] derives a closed-form expression for the output SNR of the A/D as a function of the input SNR and the A/D parameter settings.

Amoroso [9] extends previous analyses to give the performance of the adaptive two-bit A/D converter for combined CW and Gaussian interference. The converter yields substantial conversion gain even when the DSSS is much weaker than the Gaussian component of interference. The upper bound on conversion gain depends primarily on the relative strengths of the Gaussian and CW components of interference. Cai [21] discusses the optimization of the two-bit A/D converter.

Goiser and Sust [57, 58] consider digital matched filters for DSSS communications and find that minimum complexity is obtained if hard-limiting analog-to-digital converters (ADCs) are used. This structure, however, while yielding good performance in AWGN, experiences intolerable degradation for non-Gaussian interference. They propose a hard-limited two-bit ADC (with adaptive thresholds) noncoherent receiver and examine its performance in AWGN, CW, and combined CW/AWGN interference. When compared to just hard-limiting, slightly better performance in AWGN with the ADC is overshadowed by increased complexity. On the other hand, results show dramatic improvements in the presence of CW interference for little increase in complexity.

Amoroso and Bricker [6] extend the theory of A/D conversion in the case of noncoherent reception of DS PN signals and find that the A/D converter performs well in both CW and Gaussian interference. Amoroso [11] applies adaptive A/D conversion to suppress co-channel constant-envelope interference in mobile digital links. He proposes a polar adaptive A/D converter, operating in a noncoherent detection setting, that exhibits performance superior to previous Cartesian A/D converters (even when Cartesian converters are allowed to operate in a coherent detection mode).

#### *Nonlinear Techniques*

For prediction of a narrowband interferer in the presence of non-Gaussian noise (such as the SS signal itself), linear methods are no longer optimal and nonlinear methods can yield better performance. Narrowband interference can be mitigated in SS systems (such as CDMA) by techniques based on nonlinear filtering, where, for example, the CDMA signal is modeled as non-Gaussian noise in the interference-suppression process. The narrowband signal is modeled as an AR process (i.e., as the output of an all-pole linear filter



driven by AWGN). When the statistics of this AR process are unknown to the receiver, the parameters can be estimated by an adaptive nonlinear filter that uses a standard LMS adaptation algorithm to predict the interferer by incorporating a nonlinearity that takes the form of a soft-decision feedback of an estimate of the SS signal [131]. As in previous sections, the narrowband prediction is subtracted from the observation, leaving the SS signal plus AWGN.

An example of a nonlinear adaptive predictor is given in Fig. 6, where the nonlinearity involves a soft-decision feedback via the tanh function [144]. The LMS algorithm is employed in this filter where:

$$\epsilon_k = y_k - \hat{y}_k \quad (2a)$$

$$\rho(\epsilon_k) = \epsilon_k - \tanh\left(\frac{\epsilon_k}{\sigma_k^2}\right) \quad (2b)$$

$$\bar{y}_k = y_k - \tanh\left(\frac{\epsilon_k}{\sigma_k^2}\right) = \hat{y}_k + \rho(\epsilon_k) \quad (2c)$$

where  $y_k$  is the input signal,  $\rho(\epsilon_k)$  is a nonlinear function (the output of this transformation represents the residual less the soft decision on the SS signal—ideally noise),  $\hat{y}_k$  is the estimate of the interference,  $\bar{y}_k$  is the observation less the soft decision on the SS signal, the residual  $\epsilon_k$  represents observation less the interference estimate,  $w_{L,k}$  are the tap-weights,  $D$  is the delay, and  $L$  is the number of taps.

Several papers serve as background to the previous illustration. Garth, Vijayan, and Poor [49] generalize the nonlinear filter derived by Vijayan and Poor [165] and show that for channels corrupted by impulsive noise, the binary nature of the DS signals can be exploited to obtain better performance by using nonlinear filters. Garth and Poor [50] develop DSSS suppression algorithms that are based on nonlinear filters that produce predictions of the interfering signals that are then subtracted from the received signal to suppress the interference. Overall, the interference-rejection capability provided by the nonlinear filter (compared to the linear filter) for impulsive noise background is substantial.

Higbie [71] describes a nonlinear signal processing technique designed to suppress interference in DSSS receiving systems. The basic idea is to optimize the detection process dynamically, in the presence of interference, by estimating the statistics of the interference and then by using this information to derive a nonlinear transform to apply to the corrupted signal.

This adaptation is open-loop, thus avoiding convergence problems, and yields large improvements (tens of dB).

Kasparis, Georgiopoulos, and Payne [85] propose the use of a conditional nonlinear median filter, operating in the transform domain, for the detection and suppression of narrowband signals of sufficient power, without regard to their center frequency, bandwidth, or peak power. Nelson and Kasparis [119] extend this work by confronting problems incurred in Rayleigh-distributed fading channels. Their solution is a normalized adaptive median filter, which considers each received bit independently and uses a normalization metric to compensate for fading.

Jacklin, Grimm, and Ucci [83] present the performance results of a two-dimensional DSSS communications system employing locally optimal (LO) maximum likelihood detection. The LO receiver is robust in the sense that no *a priori* interference statistics are assumed. Instead, the required LO memory-less nonlinear transform is estimated directly from the statistics of the received data. The LO nonlinear processor provides a performance improvement over traditional demodulation methods when the SS system is subjected to a CW jammer, and it is shown to depend on the number of chips per information bit and the ratio of the jammer frequency to the transmitted signal's carrier frequency.

Krinsky, Haddad, and Lee [89] propose a system to adaptively mitigate burst-type interference, where the interference is modeled as a combination of an AR process and a Markov process. The optimal receiver is shown to have a computational complexity that increases exponentially with the system's processing gain. They present two suboptimal receivers, one based on the interacting multiple model (IMM) and one based on the simpler fast IMM (FIMM). Since the  $P_e$  performance of these receivers is comparable, the substantial complexity reduction offered by the FIMM-based receiver makes it the better choice. The FIMM-based receiver may be viewed as a time-varying nonlinearity. This nonlinearity is a function of the current model probabilities and interference estimates, and thus is a nonlinear function of past observations. The nonlinearity can resemble a linear filter, a soft limiter, or a noise blanker depending on the current state of the system.

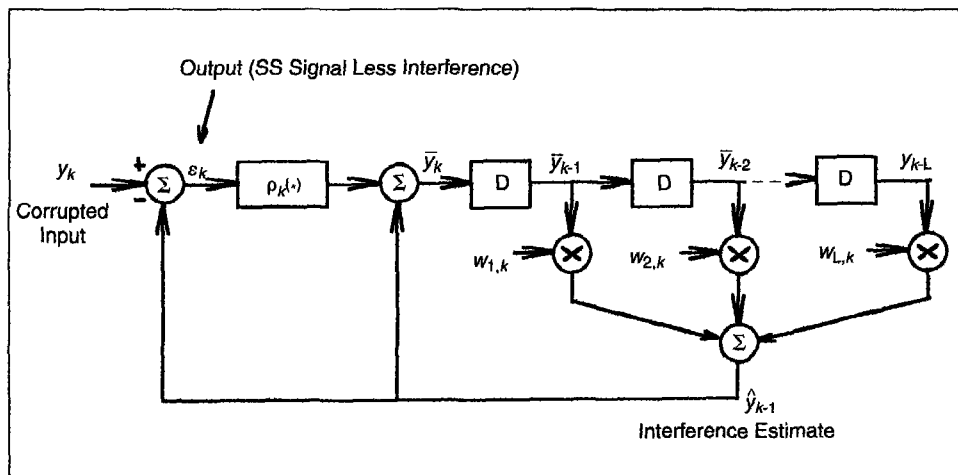

6. Nonlinear adaptive predictor, based on [144].

## Wideband Interference Rejection for Direct Sequence

Whereas the previous section focused on NBI in DSSS, this section considers ways to mitigate wideband interference in DSSS systems. A primary example of the wideband interference problem is found in CDMA systems, where all users (each with his own SS signal) share the same band and interfere with each other. Interference rejection is important to facilitate increased capacity in the licensed bands that deploy CDMA. Wideband interference rejection is also important in other applications, such as the unlicensed ISM bands (902-928 MHz and 2.4-2.835 GHz) where SS is often the best system. The commercial implications of this subject have spawned a great volume of papers in this area in recent years.

We divide this section into single-user detection and by multiuser detection. CDMA interference rejection is accomplished by both techniques. Techniques to mitigate non-CDMA wideband interference (e.g., as encountered in the unlicensed ISM bands) fall under the category of single-user detection. By single-user detection, we mean that only one user's spreading code and delay is known and utilized at the receiver. With multiuser detection, several (if not all) of the users' spreading codes and delays are known and used at the receiver. Some authors categorize single-user detection (in a multiuser environment such as CDMA) under the heading of multiuser detection, but we distinguish single-user and multiuser detection as defined above. As mentioned, Verdú [164] and Duel-Hallen et al. [41] provide surveys, wider in scope than that presented here, of various techniques proposed to mitigate MAI. An organizational chart of wideband interference rejection for a DS CDMA receiver is given in Fig. 7, which represents a combination of charts proposed by [20] and [102] for CDMA interference rejection.

The current generation of CDMA systems employs single stage correlation receivers that correlate the received signal with a synchronized copy of the desired signal's spreading code. The receiver consists of a bank of matched filters, each of which is matched to a particular user's spreading code. Conventional receivers treat MAI, which is inherent in CDMA, as if it were additive noise. However, in asynchronous systems, MAI is generally correlated with the desired signal and thus causes degradation. Synchronous systems (which allow the use of codes that make the MAI uncorrelated) can be implemented on the downlink, but not on the uplink.

In a single cell environment, CDMA systems employing simple correlation receivers cannot approach the spectral efficiency of orthogonal multiplexing schemes such as TDMA or frequency-division multiple access (FDMA) [135]. Furthermore, correlation receivers are particularly susceptible to the near-far problem when MA signals are received with different signal powers. Even if sophisticated power control is employed, the near-far effect can still result in significant performance degradation. Greater channel capacity for CDMA can be achieved by using interference-rejection techniques to mitigate MAI.

### Single-User Detection

By single-user detection, we mean that only one user's spreading code and delay are known at the receiver. The structure (such as spreading codes, delays, and powers) of the MA interferers are assumed to be unknown. The complexity in single-user detection is generally much smaller than that of multiuser detection. Single-user schemes can be adaptive or fixed. We focus on adaptive techniques, which can be categorized as chip-rate structures or fractionally spaced structures. A general block diagram of a fractionally spaced adaptive single-user receiver based on [139] is given in Fig. 8 for CDMA.  $T_f$  represents fractionally spaced sampling,  $T$  is the symbol interval,  $\mathbf{r}$  is the sampled received signal,  $\mathbf{b}$  is the decision statistic, and  $\omega_c$  is the carrier frequency.

**Chip rate.** Using the minimum mean squared error (MMSE) criterion, Madhow and Honig [99, 100, 101] consider interference suppression schemes for DSSS CDMA systems. They look at  $N$ -tap chip-rate filters, the cyclically shifted filter bank, and data-symbol oversampling. These schemes have the virtue of being amenable to adaptation and simple implementation (in comparison to multiuser detectors), while, at the same time, alleviating the near-far problem to a large extent. The channel output is first passed through a filter matched to the chip waveform and then sampled at the chip rate. Because of the complexity and coefficient noise associated with such an adaptive filter when spreading gain,  $N$ , is large, simpler structures with fewer adaptive components are proposed. In each case, the multiple samples per symbol are combined via a TDL, where the taps are selected to minimize the MSE.

Honig, Madhow, and Verdú [74] propose an interesting and simple blind multiuser linear detector that requires only knowledge of the desired user's signature sequence (and associated timing). The received amplitudes need not be known or estimated, and the signature waveforms of the interferers need not be known. The technique is blind because training sequences are not required for any user. The detector always converges to an optimally near-far resistant solution. The strategy is to minimize the output error, which is equivalent to minimizing the MSE (but without the requirement of training sequences). The authors give an overview of blind multiuser detection in [72]. Honig [75] also proposes a blind algorithm using the orthogonal Sato cost criterion, which leads to a stochastic gradient algorithm that has advantages relative to the minimum variance algorithms.

Tahernezhad and Zhu [155] evaluate the BER performance of two adaptive schemes in asynchronous CDMA—the  $N$ -tap filter and the  $D$ -tap cyclical shifted filter-bank filter. LMS and predictive LMS are employed for the adaptation of the tap weights.

Ström and Miller [153] present a common mathematical framework for comparing simpler structures in terms of their probability of bit error, deriving the form of the optimum complexity (dimension) reduction. They propose a simple scheme called symmetric dimension reduction (SDR), which is shown to outperform the cyclically shifted filter-bank

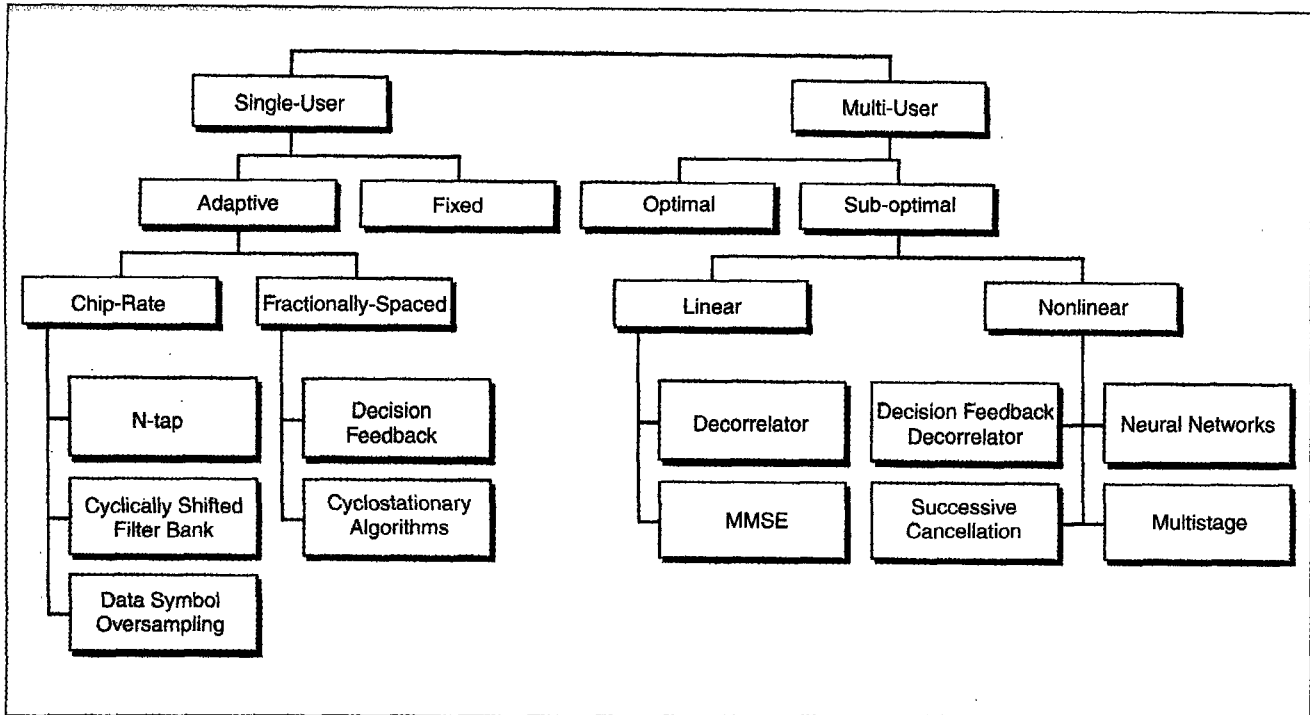

7. Organizational chart for wideband interference rejection in direct-sequence spread spectrum (e.g., CDMA) [20, 102].

structure [99] (another complexity-reduction scheme). Miller [110] proposes an adaptive receiver that uses a chip-matched filter followed by an adaptive equalizer to perform the despreading operation. The receiver is shown to be immune to the near-far problem.

Lee [94] presents rapidly converging adaptive equalization algorithms for interference suppression in DS/CDMA. The algorithms, based on an orthogonal transformation, do not require *a priori* knowledge of interfering signal parameters, such as spreading-code sequences and relative signal power levels. The convergence rate of these algorithms is independent of the eigenvalue spread of the input data correlation matrix. Lee's proposed adaptation algorithm is shown to be superior to LMS and RLS.

**Fractionally spaced. Decision Feedback:** In the context of DSSS CDMA, Abdulrahman, Falconer, and Sheikh [2, 3, 4] present work on a receiver consisting of a spread sequence matched filter (SSMF), matched to a desired user's spreading code, followed by a fractionally spaced decision feedback equalizer (DFE) MMSE filter. This technique does not need the assumption that the spreading sequences of all users are known at the receiver; the receiver only uses information about the desired user's spreading code and a training sequence. The authors document performance in slow fading and how a fractionally spaced DFE can be used as a CDMA demodulator. In an implementation that does not require knowledge of any user's spreading code, the authors replace the SSMF with an LPF having a bandwidth equal to the spread signal band-

width. Simulation of both receivers yields better MMSE performance by the SSMF receiver.

Rapajic and Vucetic [137] describe a fully asynchronous single-user receiver in a CDMA system where the receiver is trained by a known training sequence prior to data transmission and continuously adjusted by an adaptive algorithm during data transmission. An adaptive, fractionally spaced LMS filter, instead of a matched filter with constant coefficients, is employed for each user separately. Experimental results show that a considerable improvement in BER is achieved with respect to the conventional single-user receiver. In [138], Rapajic and Vucetic consider additional adaptive linear and DF structures for coherent demodulation in asynchronous CDMA. In [139], they also investigate the use of adaptive transmitters and receivers, where it is assumed that there is no knowledge of the signature waveforms and timing of other users. The transmitter adapts based on feedback information from the receiver, which is used to calculate the optimum transmitter signature. The signatures are adaptively adjusted according to the MSE criterion during the training period as well as during data transmission. CDMA systems

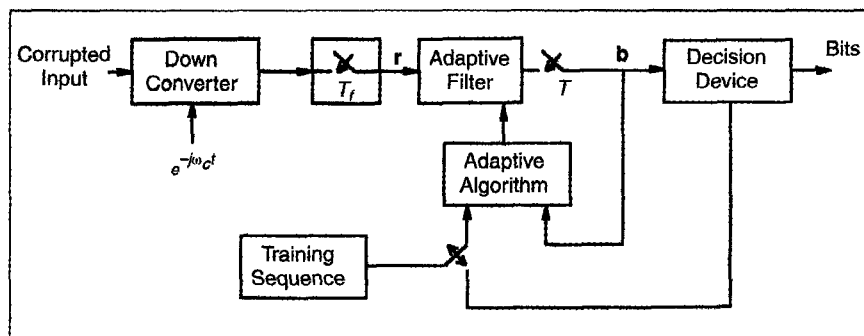

8. Block diagram of an adaptive single-user receiver in CDMA, based on [139].

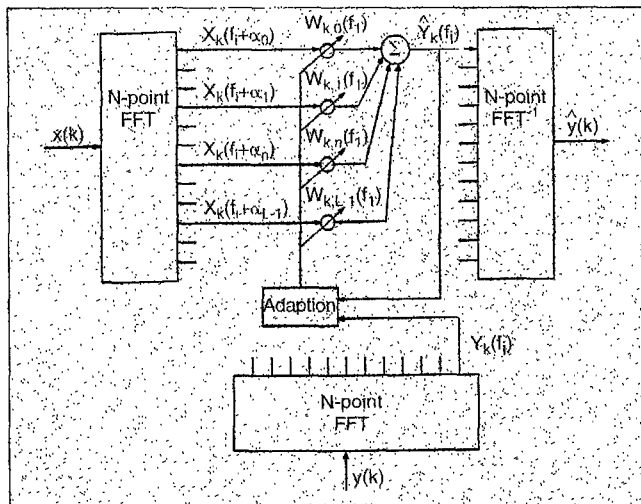

9. FFT time-dependent adaptive filter structure (frequency-domain implementation) showing estimation of one output bin.

employing the adaptive transmitters in the presence of MAI achieve the matched filter bound with no interference.

**Cyclostationarity Algorithms:** Many signals exhibit cyclostationarity; that is, the statistics of the signal are periodic, with resulting spectral correlation. A complete analysis of cyclostationarity in DSSS signals has been presented by [26]. Fundamental statistical periodicities exist at the chip rate, data rate, and code repetition rate, with  $\alpha$  denoting the cycle frequencies associated with these periodicities. Cyclostationarity-exploiting algorithms which, in many instances, resemble fractionally spaced equalizers (FSEs) [12, 13], represent another class of techniques for combating MAI. Although essentially equivalent to the MMSE structures presented earlier, the framework of the analysis is different and provides additional insight to the problem. A complete analysis by Agee [5] shows that the stability and efficiency of near-far power management strategies used in CDMA are greatly enhanced by exploiting the spectral diversity of CDMA networks. Specifically, spectral diversity is easily exploited in CDMA networks employing modulation-on-symbol DSSS modulation formats where the direct-sequence code repeats once per message signal.

Holley and Reed [73] and also Aue and Reed [12, 13] show how spectral correlation properties can be exploited by a time-dependent adaptive filter (TDAF). This technique provides increased capacity for CDMA close to that of FDMA or TDMA using frequency-domain and time-domain filtering structures. CDMA capacity plots shown in [73] are typical of those found in FDMA and TDMA. The idea is to view the spreading process as replicating the data sequence on multiple carriers spaced at multiples of the code repeat rate. The adaptive filter combines this replicated spectrally correlated data using a time-varying filter. A frequency-domain implementation is shown in Fig. 9, where  $x(k)$  is the received signal,  $\alpha$  is the code repetition rate cycle frequency,  $y(k)$  is the desired signal, and  $\hat{y}(k)$  is the estimate of the desired signal.

Monogioudis, Tafazolli, and Evans [113, 114] employ a technique based on adaptive linear fractionally spaced

equalization (LFSE) to adaptively cancel MAI in CDMA systems. Simulation results indicate that the LFSE offers significant gains over the conventional detector, eliminating the near-far problem without explicit knowledge of the interfering spreading sequences. The  $E_b/N_0$  degradation due to multipath propagation is insignificant, so that the LFSE is also able to combine optimally the multipath rays and act as an adaptive Rake combiner-canceller.

Yoshida, Ushirokawa, Yanagi, and Furuya [173] propose an adaptive interference canceler (AIC) consisting of a fractionally chip-spaced code-orthogonalizing filter (COF) and a differential detector. Using only the desired spreading code, the COF adaptively makes its tap coefficients orthogonal to all other users' spreading codes by minimizing the MSE between the detected and decision signal. The COF is a linear adaptive filter used to cancel MAI. After the MAI cancellation, the differential detector removes fast phase variation in the desired carrier due to fading. Placed separately from the COF, the differential detector determines the tracking ability for fast fading. A DS/CDMA system using the proposed AIC is able to accommodate an increased number of MA users when compared with the case of using the conventional matched filter receiver.

#### Multiuser Detection

Much of the motivation for designing better multiuser detectors results from the theoretical capacity work of Verdú [163] for optimal CDMA receivers. Multiuser detectors require that all CDMA users' spreading codes and delays are known at the receiver. Verdú shows that the near-far problem is not an inherent flaw of CDMA, but results from the inability of the conventional receiver to exploit the structure of the MAI. Because, however, the optimal receiver is hopelessly complex, several suboptimal receivers have been proposed to approximate it, resulting in a large number of published papers. These detection schemes are considered adaptive because they adapt to the changing channels of the users to track delays and often power levels.

**Optimal.** A block diagram for an optimum  $k$ -user detector for an asynchronous multiple-access Gaussian channel is given in Fig. 10 [163]. The received signal,  $r(t)$ , is a corrupted composite of the  $K$  CDMA users with  $s_k$  as the unit-energy signature waveforms. The received signal passes through a bank of matched filters, where each filter is matched to a particular user's spreading code. The outputs of the matched filters are sampled, with knowledge of each user's delay (i.e., sync), yielding  $y_k(i)$ , which are passed through a decision algorithm to produce the estimates  $\hat{b}_k(j)$  of the desired signals.

Generally, the optimum receiver processes the received waveform with a bank of matched filters, which produce a vector of observables:

$$\mathbf{y} = \mathbf{R}\mathbf{A}\mathbf{b} + \mathbf{n} \quad (3)$$

where  $\mathbf{A} = \text{diag}\{A_1, \dots, A_k\}$ ,  $A_k$  is the received amplitude of the  $k$ th user,  $\mathbf{b} = \{b_1, \dots, b_k\}^T$ ,  $b_k \in \{-1, +1\}$  is the data stream

modulated by the  $k$ th user,  $\mathbf{n}$  is a zero mean Gaussian vector, and  $\mathbf{R}$  is the cross-correlation of  $s_k$  (the unit-energy signature waveforms of the  $k$ th users) [164].

**Suboptimal. Linear:** An example of a suboptimal receiver is the decorrelating detector [98] that multiplies the matched filter outputs in Eq. (3) by the inverse cross-correlation matrix  $\mathbf{R}^{-1}$ , i.e., it takes the sign of the vector:

$$\mathbf{R}^{-1}\mathbf{y} = \mathbf{A}\mathbf{b} + \mathbf{R}^{-1}\mathbf{n} \quad (4)$$

For frequency-nonselctive Rayleigh fading asynchronous CDMA channels, Zvonar and Brady [179] focus on two low-complexity suboptimal multiuser receivers with diversity reception, namely a coherent decorrelating and a differentially coherent decorrelating detector. They also analyze an adaptive coherent multiuser receiver utilizing decision-directed carrier recovery and maximal ratio combining. They bound its error probability showing the impact of imperfect channel estimates and MAI. The comparison of two receiver structures indicates that the coherent decorrelating detector with diversity reception is preferable in nonselective fading CDMA channels with memory.

A linear MMSE multiuser detector can outperform a decorrelating detector when all the interferers are very weak. The linear MMSE detector replaces the inverse cross-correlation matrix  $\mathbf{R}^{-1}$  by the matrix:

$$[\mathbf{R} + \sigma^2\mathbf{A}^{-2}]^{-1} \quad (5)$$

where  $\sigma^2$  is the background-noise power-spectral density.

Mandayam and Aazhang [104] consider a DS-CDMA system from the framework of a discrete event dynamic system (DEDS) and develop infinitesimal perturbation analysis (IPA) for estimating the sensitivity of the average probability of bit error in such systems. The estimates are shown to be unbiased, and this technique is then further incorporated into a stochastic gradient algorithm for achieving adaptive multiuser interference rejection. They develop an algorithm for an adaptive linear detector with the average probability of error being the minimization criterion. The algorithm is shown to

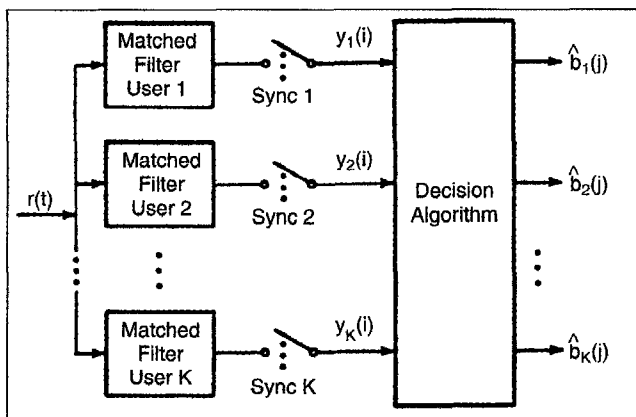

10. Optimum  $K$ -user detector for asynchronous multiple-access Gaussian channels [163].

converge, and the resulting detector performs better than the MMSE detector.

Monk, Davis, Milstein, and Helstrom [115] approximate MA noise by a Gaussian process of the same power spectral density, leading to the criterion of maximizing SNR. They propose and analyze receivers that maximize SNR under various constraints, without requiring locking and despreading multiple-arriving CDMA signals.

**Nonlinear Detection:** Nonlinear detection techniques include decorrelating DF, neural networks, successive interference cancellation, and multistage techniques.

Duel-Hallen [40] proposes a decorrelating DF detector for synchronous CDMA that utilizes decisions of the strongest users when forming decisions for the weaker ones. The complexity of the DF is linear in the number of users, and it requires only one decision per user. Performance gains with respect to the linear decorrelating detector are more significant for relatively weak users, and the error probability of the weakest user approaches the single-user bound as interferers grow stronger. The error rate of DF is compared to those of the decorrelator and the two-stage detector.

Neural networks are receiving increased interest for SS applications. These advanced algorithms simultaneously account for nonlinearity, nonstationarity, and non-Gaussianity. Haykin provides a good introduction into how neural networks expand the horizons of signal processing [68]. Mulgrew [117] also provides an overview into how RBF neural networks (discussed later) can be applied in SS systems.

Multiuser detection using a backpropagation neural net is proposed by Aazhang, Paris, and Orsak [1] to approximate the highly complex optimal receiver. Mitra and Poor [111] also investigate neural network techniques to adaptively determine unknown system parameters. They show that the optimal multiuser receiver for synchronous detection of DSSS multiple access (SSMA) signals can be implemented with a RBF network. The authors consider how to find the optimal weights and the use of clustering methods to determine the centers of the RBF neurons. Simulations show that the RBF network has the desirable properties of moderate weight convergence rate and near-optimal performance in realistic communication environments.

Under the category of tentative-decision-based multiuser detection, Verdú [164] discusses successive cancellation and DF. The idea is to estimate and cancel each user successively. For example, one would detect the data of the strongest user with a conventional detector and then subtract the signal due to that user from the received signal. This process assumes extremely accurate estimation and ordering of received user amplitudes. Viterbi first proposed the use of successive cancellation for CDMA [166], yet in a more recent paper [167] Viterbi states that, at best, this type of interference cancellation would have a similar effect to having same-cell-user orthogonality, and at worst, successive cancellation may lack robustness and, consequently, may make matters worse. Viterbi concludes that the processing complexity and possible processing delay make the application of successive cancellation questionable. Nevertheless, research continues in this

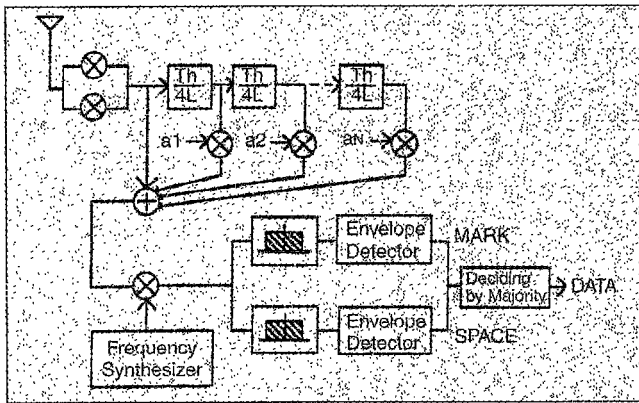

11. Hard-limited combining receiver using a transversal receiver.

area because of the large capacity gains that have been demonstrated theoretically [127].

Multistage techniques also involve making estimates and canceling, where the number of stages represents the number of times that estimates of all the users are made. Successive cancellation could be the first stage of a multistage receiver. We do not cover these multistage techniques in depth; nevertheless, they represent a useful class of techniques for rejecting MAI.

A few examples illustrate multistage detection. Grant, Mowbray, and Pringle [60] model the subscriber interference through channel measurement to permit adaptive cancellation of co-channel CDMA interference. Using a conventional first stage, the authors [116, 133] show a theoretical upper bound on the spectral efficiency approaching 130% or 1.3 normalized channels per hertz for successive cascaded cancellation stages, but their simulations only approach about 80%. Better results might be obtained by using a more accurate first stage. Proposing an adaptive version of a multistage detector, Bar-Ness, Siveski, and Chen [15, 151] present a bootstrapped decorrelating algorithm for adaptive interference cancellation in synchronous CDMA. A combination of a correlation detector and a multiuser AIC uses weight-control criterion based on minimizing the correlation between the signals at the outputs of the canceler. Its performance is compared to that obtained with the minimum power criterion. In [178], Zhu, Ansari, and Siveski investigate this adaptive synchronous CDMA receiver in more depth.

### Interference Rejection for Frequency Hopping

Interference rejection for FH is not as well developed as interference rejection for DS or for CDMA. Typically, FH interference-rejection techniques often employ a whitening stage to reject narrowband and wideband interference. In some instances, they also use the transient property of the hopper to distinguish it from persistent background interference.

Kurita, Sasase, and Mori [90] examine the performance of a hard-limited combining receiver using fractional tap-spacing transversal filters in fast frequency hopping (FFH) BPSK systems in the presence of stationary NBI. A block diagram of their receiver is given in Fig. 11. The fractional tap-spacing filter uses a tap spacing of  $T_h/4L$ , where  $T_h$  is the

duration of each hop and  $L$  is the total number of hops. The output of the transversal filter is demodulated to FFH-BPSK signals that are lowpass filtered and envelope detected. After each chip is decided, MARK (1) or SPACE (0), the bit is decided by the majority. The tap coefficients,  $a_k$ , are updated by an adaptive algorithm. The BER performance of the proposed receiver does not have an error floor and is superior to that of a hard-limited combining receiver without the transversal filters (which is shown to have a lower bound in BER with interferers in two frequency slots).

Unlike DS signals, FH signals are instantaneously narrowband, but when observed over a time span encompassing multiple hops, the FH signal becomes wideband. Exploiting this property, Iltis [80] shows how prewhitening filters designed using linear LS estimation techniques can be applied to improve the detection performance of FH signals. Iltis presents two interference-suppression filters. One filter—with taps spaced at the hop duration,  $T_h$ —can reject interference with a bandwidth of up to  $\pi/T_h$  radians/sec. A second filter uses fractionally spaced taps at intervals of  $T_h/L$  (where  $L$  is the number of hops) and rejects interference with a bandwidth of up to  $L\pi/T_h$  radians/sec, providing improved detection performance when the FH signal is linearly combined over  $L$  hops.

Iltis, Ritcey, and Milstein [82] describe an FFH receiver that employs a prewhitening filter to reject NBI. By using an appropriate fractional tap spacing, it is shown that the interference can be estimated independently of the desired signal. This LS interference-rejection technique is shown to compare favorably with the maximal-ratio combiner technique.

Reed and Agee [141] extend and improve on the idea of whitening by using a time-dependent filter structure to estimate and remove interference, based on the interference spectral correlation properties. The detection of FH SS in the presence of spectrally correlated interference is nearly independent of the signal-to-interference ratio (SIR). The process can be viewed as a time-dependent whitening process with suppression of signals that exhibit a particular spectral correlation. The technique is developed from the maximum-likelihood estimate of the spectral frequency of a frequency agile signal received in complex Gaussian interference with unknown spectral correlation. The resulting algorithm uses the correlation between spectrally separated interference components to reduce the interference content in each spectral bin prior to the whitening/detection operation.

Glisic and Pajkovic [54, 55, 56] analyze the performance of a DS QPSK SS receiver using adaptive filtering to reject a FH MA signal. Considering the adaptive prediction error filter with two-sided taps, they show graphically the conditions and number of FH MA signals that can be efficiently suppressed using adaptive filtering in a DSSS receiver.

Bishop and Leahy [18] present a technique for enhancing a wideband signal of narrow instantaneous bandwidth, such as an FH signal, from wideband and NBI. The central concept is that statistical estimation inherently involves a time average with an accompanying convergence time, and this property can be used to separate signals. A device, such as

an ALE, that separates wideband and narrowband waveforms can use this property to distinguish the SOI from the interference.

Gulliver [65] proposes a concatenation of order statistics (OS) and normalized envelope detection (NED) to combat noise and multitone jamming. He shows that the OS-NED method significantly improves the performance of NED alone in multitone jamming, with only slight degradation in noise jamming.

## Nonspread-Spectrum Techniques

A number of techniques exist for rejecting interference for non-SS signals. Many of these techniques, such as the constant-modulus algorithm (CMA) and decision-directed adaptive filtering, are well-known adaptive equalization techniques. In addition, some emerging interference-rejection techniques that are based on neural nets, time-dependent filtering (which exploits spectral correlation), and nonlinear filtering show great promise.

### Adaptive Equalization

Some techniques for interference rejection find their roots in adaptive equalization research, which primarily focuses on mitigating ISI. Much research on adaptive equalization has been documented in the literature. Proakis devotes an entire chapter to adaptive equalization in his thorough textbook on digital communications [134]. Because this overview focuses on channel interference and not ISI, only adaptive equalization work that is combined with interference rejection is surveyed. The following papers illustrate the application of adaptive equalization to interference rejection. An example of an adaptive linear equalizer (AEQ) is given in Fig. 12 [122], where  $T$  is the symbol duration. The ideal equalizer will extract the transmitted signal,  $s(k)$ , from the received data at each instance in time.

North, Axford, and Zeidler [122] analyze the effects of interference on the steady-state performance of several adaptive equalization algorithms and show that the built-in capability to reject NBI deteriorates in performance as the bandwidth of the interference increases. The existence of a time-varying misadjustment component in the adaptive equalizer weight vector is shown to affect the interference-cancellation properties. By decomposing the output of the AEQ into a Wiener filter (WF) term and a misadjustment filter (MF) term, the authors interpret the AEQ as a device that rejects interference by creating a notch in the frequency response of the WF, but that the time-varying MF under certain conditions fills the notch (i.e., compensates for WF-generated ISI), thereby improving performance over that of the WF alone.

Niger and Vandamme [121] show that synchronous decision-feedback equalizers are powerful countermeasure

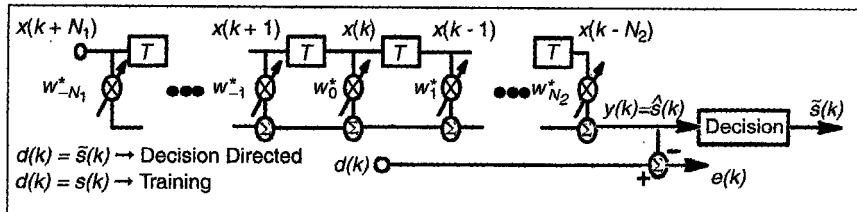

12. A two-sided  $T$ -spaced adaptive linear equalizer [122].

devices for radio channels affected by both selective fading and sinusoidal interferers. They demonstrate that both  $T/2$ -spaced linear and nonlinear equalizers can provide a significant improvement of the ACI margin, especially in the case of multicarrier interleaved-frequency arrangements.

Considering narrowband TDMA, Lo, Falconer, and Sheikh [96, 97] investigate the performance of an adaptive fractionally spaced DFE in the presence of CCI, ACI, and additive Gaussian noise for a frequency-selective quasi-static channel environment. A directly adapted recursive least-squares (RLS) DFE performs better than a computed MMSE DFE, which employs estimates of the channel impulse response and the autocorrelation of interference plus noise. The use of a wide receiver bandwidth yields a performance improvement for channel spacings that allow for sufficient spectral overlap of ACI with the desired signal bandwidth. Thus, a reduction in channel spacing increases the radio capacity while maintaining a desired average BER or outage performance.

Yoshino, Fukawa, and Suzuki [174] propose an adaptive interference-canceling equalizer (ICE) that uses RLS maximum-likelihood-sequence-estimation (RLS-MLSE) to cancel CCI in the received signal in Rayleigh fading environments. Fukawa and Suzuki [46] discuss in detail a blind ICE that can operate well without training signals for the interference.

Petersen and Falconer [130] describe the ability of a linear equalizer/combiner or DF equalizer to suppress all received ACI, CCI, and ISI. They found that with one antenna and a linear equalizer, arbitrarily large receiver bandwidths allow for marginal improvements in spectral efficiency through decreased carrier spacing, because the carrier spacing cannot be reduced to a value below the symbol rate without incurring unsuppressible interference. Their results demonstrate how equalizers are able to extract the SOI and provide interference suppression even under conditions of considerable mutual overlap of all signals. Greater interference suppression is possible using equalizers with larger receiver bandwidths.

Other parts of this overview contain examples of adaptive equalization as applied to interference rejection, including the two sections dealing with CDMA interference rejection presented earlier. The mechanism for non-SS equalizer operation tends to be different from that in SS. For example, equalization in SS tends to operate by exploiting the code-repetition feature. Several non-SS techniques also utilize adaptive equalization, including those employing the CMA, neural networks, spectral correlation, and nonlinear techniques.

## Constant-Modulus Algorithm

Interference and channel distortion will alter the envelope of a constant-modulus (envelope) signal, such as FM or QPSK. For constant-modulus signals (e.g., FM, FSK, and PSK), the CMA works by adapting a filter to restore the constant envelope, thereby rejecting interference and suppressing channel distortion. Treichler and Agee [159] originally formulated CMA where, by sensing the received envelope variations, the complex coefficients of an FIR filter can be adapted to remove the variations and, in the process, remove interference components from the received signal. Much of the literature on CMA focuses on its equalization capability. Here, literature is addressed that investigates CMA's interference-rejection capability. An example of CMA is given in Fig. 13. The error that drives the adaptive (adjustable) filter is derived from the difference between a constant and the magnitude of the output of the filter.

A real-input, real-coefficient version of CMA is formulated by Treichler and Larimore [160], and the algorithm is extended for the enhancement of signals having a nonconstant but known envelope, as might arise in data signals with pulse shaping. Treichler and Larimore [161] also survey developments in applying CMA.

Ferrara [45] presents a method for adaptively canceling interference from a constant-envelope target signal, even when some of the interfering signals also have constant envelopes. The adaptive algorithm distinguishes between target signal and interference on the basis of signal amplitude and envelope shape, given that the amplitude of the target signal is approximately known or measurable.

Gooch and Daellenbach [59] describe a technique for preventing interference capture by using a spectral whitening algorithm to initialize the filter weights prior to switching to the CMA. The method requires no knowledge of the received interference scenario, and it allows notching of one or more interferers. Satorius et al. [146] compare the interference-rejection performance of the CMA to linear prediction or whitening techniques.

Rude and Griffiths [143] develop a fractionally spaced adaptive equalizer based on the linearly constrained constant-modulus (LCCM) algorithm. The LCCM algorithm exploits prior knowledge of synchronization, sampling strategy, and pulse shape to prevent capture of the CMA by narrowband constant-envelope interferers. LCCM uses *a priori* knowledge of only the SOI. Simulations show that this approach greatly reduces the vulnerability of CMA to strong constant-envelope interferers and yields a set of tap values that can be successfully used as initial conditions for follow-on DF adaptation.

Kwon, Un, and Lee [91] investigate the convergence properties of CMA when applied to interference rejection, by analyzing the convergence behavior of the squared-output modulus and the MSE of the modulus. They find that the convergence behavior can be modeled by a recursive equation with a varying convergence factor.

White [171] addresses the problem of blind equalization of constant-modulus signals that are degraded by frequency-selective multipath propagation and additive white noise. An adaptive observer is used to update the weights of an FIR equalizer in order to restore the signal's constant-modulus property. The observer gain is selected using fake algebraic Riccati methods in order to guarantee local stability. When compared to the CMA for simulated FM-frequency division multiplexing (FDM) signals, the performance of this method exhibits significantly better convergence properties, particularly for heavy-tailed noise.

## Neural Networks

Howitt, Reed, Vemuri, and Hsia [76] survey recent developments in applying neural networks (nets) to equalization and interference rejection. Haykin [68] also provides an introduction to the use of neural networks in signal processing. Advantages of neural nets over conventional linear filtering and equalization include: (1) better rejection of non-Gaussian interference, (2) superior rejection of noise, (3) availability of additional blind equalization algorithms, (4) more robust startup, (5) capability of rejecting CDMA interference, (6) better equalization of nonminimal phase channels, and (7) better compensation of nonlinear distortion. On the negative side, with present neural net equalization techniques, there is no guarantee of reaching an optimal solution, and the convergence rate is very slow (and therefore not as viable for dynamic channels).

The ability of neural networks to reject interference can be viewed using different perspectives; that is, 1) neural nets can create nonlinear decision boundaries between signal states, 2) neural nets provide a means of implementing nonlinear filters for rejecting non-Gaussian interference, and 3) neural nets can be used to identify specific error patterns. Three types of neural nets stand out—a feed-forward neural nets (trained using a variant of the backpropagation algorithm), those based on the polynomial perceptron, and those utilizing RBFs. Neural networks using a self-organizing feature map (SOM) are also used for adaptive equalization and interference rejection, but are only referenced here [136, 128, 38]. Applications of neural nets to interference rejection for SS can be found in the section on single-user detection presented earlier.

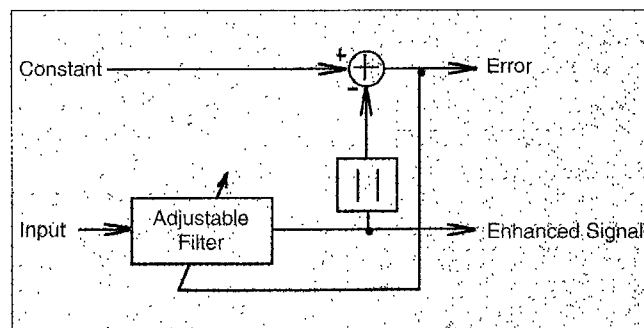

13. Implementation of the constant-modulus algorithm.



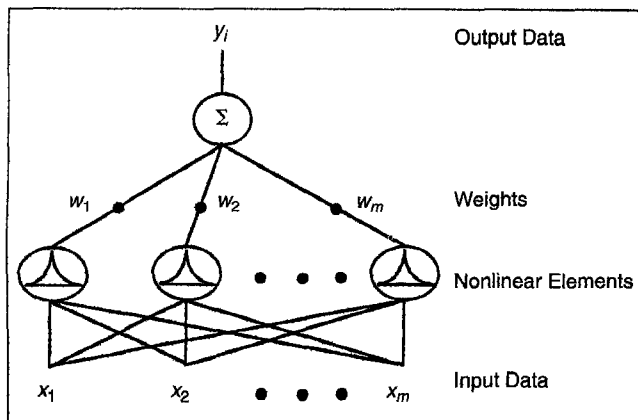

14. An example of a radial basis function neural net.

### Radial Basis Function

The most promising work to date for interference rejection is with the use of RBFs. A general example of an RBF two-layer neural net is given in Fig. 14, where the input data,  $x_m$ , are passed through some nonlinear function (such as a Gaussian function) before being weighted and summed, and  $m$  is the dimension of the input space. The first layer (the hidden layer) takes the input vector  $\mathbf{x}$  and produces a nonlinear mapping based on the nonlinear elements. The second layer is a linear mapping from the output of the hidden layer to the output of the network (i.e., a weighted sum of the hidden-layer output). RBF networks exploit the premise that a classification problem transformed into a higher dimension through a nonlinear mapping is more likely to be solved than if the solution to the problem is attempted in its original space [76].

Cha and Kassam [24] give an overview of adaptive interference cancellation with RBF networks. They investigate the applicability of the RBF network in adaptive-interference-cancellation problems. An extended structure that combines a linear canceller with an RBF network is shown to be more robust than a structure using an RBF network only. In [25], they study RBF networks from the perspective of optimal signal estimation. Optimum interference cancellation usually requires nonlinear processing of signals. Since RBF networks can approximate nonlinear functions, they can be expected to implement or approximate the operation of optimum interference cancellation with appropriate network configuration and training. Cha and Kassam examine a number of different RBF structures as well as training algorithms, showing that RBF networks can be very

useful for interference-cancellation problems in which traditional linear cancelers may fail badly.

Chen and Mulgrew [22, 27] show the results of using an adaptive RBF neural net for interference rejection and equalization. They state that an adaptive RBF neural net equalizer can implement the optimal Bayesian symbol-decision equalizer using a two-stage learning algorithm. The first stage is a supervised or decision-directed clustering algorithm that learns the centers of the desired signal states, and the second stage is a variation of an unsupervised  $k$ -means clustering algorithm for modeling the effect of the interference. In one example, the neural net provides an effective reduction in SINR of 7 dB over the transversal equalizer for a BER of  $10^{-4}$ . The algorithm converges remarkably fast when compared to traditional equalization algorithms. Chen, McLaughlin, and Mulgrew [23] apply the results to digital communication channel equalization and incorporate CCI compensation [28].

A means for growing the RBF network in interference-rejection applications is addressed by Howitt et al. [77]. Howitt points out that direct correspondence can be obtained between RBF networks and the symbol-by-symbol maximum likelihood receiver structure for equalization in the interference environment and also for continuous phase modulation (CPM) receivers [79].

### Feed-Forward Networks with Backpropagation

Nonlinear adaptive equalizers have been implemented using a feed-forward neural net with backpropagation. This structure can also reject interference. The general implementation scheme is a straightforward extension of the linear transversal equalizer (LTE) as shown in Fig. 15, where  $\hat{y}_i$  is the input,  $\hat{x}_i$  is the output, and  $x_i$  is a desired signal. The figure includes a DF extension to the basic transversal equalizer [76].

Bijjani and Das [17] present a multilayer backpropagation perceptron model as a means of detecting a wideband signal

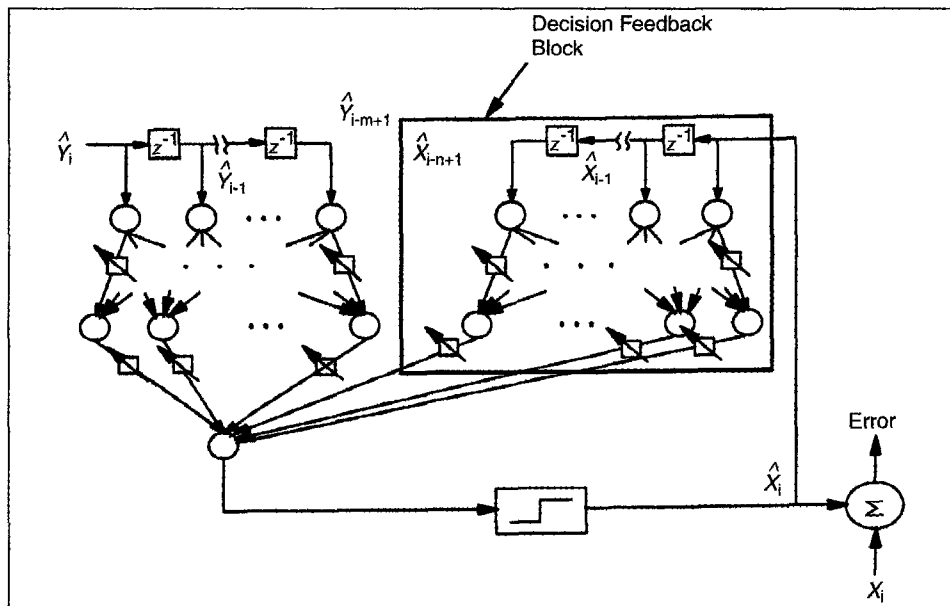

15. Feed forward neural network adaptive equalizer with optimal decision feedback [78].

in the presence of narrowband jammers and additive white noise. The nonlinear neural network filter is demonstrated to offer a faster convergence rate and an overall better performance over the LMS adaptive transversal filter.

Zengjun and Guangguo [175] describe a fractionally spaced DF multilayer perceptron (FSDFMLP) for adaptive multilevel QAM digital mobile radio reception that can reject CCI and AWGN simultaneously. The FSDFMLP is trained by a fast adaptive learning algorithm, called the mixed gradient-based fast learning algorithm (FLA), with variable learning gain and selective updates (based on a combination of the steepest descent and the conjugate gradient methods). FSDFMLP can perform more efficiently than the conventional LMS-based DF filter in the presence of multipath fading of channels with non-Gaussian interferences. Similarly, Zengjun and Guangguo [176] describe the complex neural-network-based adaptive DF filter (CNNDFF) for M-QAM digital communication reception systems. Experimental results indicate that the CNNDFF can simultaneously overcome the performance degradations due to multipath fading of channels and reject the non-Gaussian CCIs efficiently. The convergence rate of the CNNDFF is significantly better than that of the standard backpropagation network.

#### Polynomial Perceptrons

Another adaptive nonlinear equalizer (ANLE) approach is the polynomial perceptron. The idea behind this approach is to approximate the decision function based on the Volterra series polynomial expansion. Figure 16 illustrates the polynomial perceptron for a two-input, third-order structure, where  $\hat{y}_i$  is the input,  $\hat{x}_i$  is the output, and  $w_i$  are the weights.

The complexity is greater than that of the LTE but less than that of the feed-forward network (assuming the order of the network is moderately low).

Zengjun and Guangguo [62] present methods of joint adaptive-channel equalization and interference suppression by neural networks in digital communications systems with high spectrum efficiency and high bit rate. They propose a

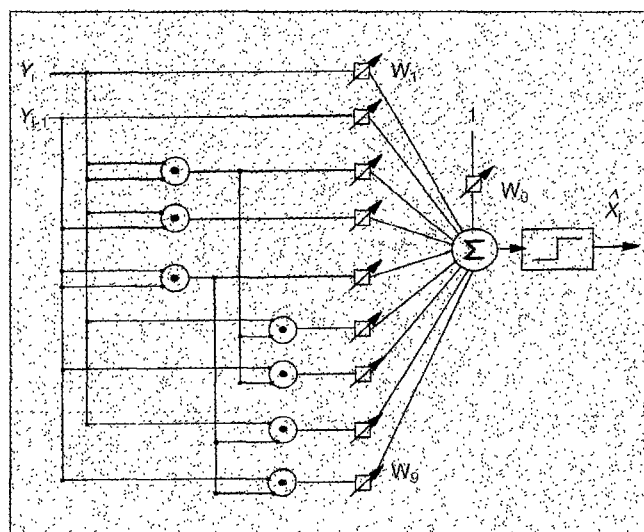

16. Polynomial perceptron structure [78].

lattice polynomial perceptron (LPP) and a FLA to train the LPP. Their simulations show improvement of the LPP over the multilayer perceptron and backpropagation algorithm.

Zengjun and Guangguo [63, 177] extend their previous work by investigating the behaviors of polynomial perceptrons (PP). They show that a PP with degree  $L$  (8 4) satisfies the Stone-Weierstrass theorem and can approximate any continuous function to within a specified accuracy. They also introduce a fractionally spaced recursive polynomial perceptron (FSRPP) with low complexity and fast convergence rate. The FSRPP is a structure of PP that requires a smaller number of coefficients. A fractionally spaced bilinear perceptron (FSBLP) is a simple FSRPP. Simulation results show the performance of the FSBLP is superior to that of previously investigated structures, including the conventional DFE, due to the use of the sigmoid function and the cross terms.

#### Exploitation of Spectral Correlation

An adaptive filter is a time-varying filter, where the filter coefficients change with time, minimizing some error criterion function. If the signal statistics change rapidly, a conventional adaptive filter is incapable of converging to the optimum solution, as is often the case in applications when an adaptive filter is used for filtering digitally modulated signals. When these signals exhibit periodic statistics, they are generally referred to as cyclostationary signals, possessing the property of spectral correlation. Reed and Hsia [140] present the basic theory of the TDAF, which allows for the cyclostationary nature of communications signals by periodically changing the filter and adaptation parameters. By exploiting spectral correlation, the TDAF achieves improved interference rejection capability over that of conventional time-independent filters.

Analog and digital carrier-modulated signals, such as AM, digital QAM, PSK, and FSK, exhibit correlation among spectral components separated by multiples of the keying rate and separated by the doubled carrier frequency plus multiples of the keying rate. Gardner and Venkataraman [48] observe that this spectral redundancy can be exploited to facilitate rejection of CCI, while maintaining minimal signal distortion. Gardner and Brown [47] show how spectral redundancy can be exploited by multichannel frequency shift filtering of the corrupted data and by adding the results to implement a time-dependent filter.

Gardner [51] develops some of the theoretical concepts underlying this type of filtering and summarizes the theory of optimal FREquency SHift (FRESH) filtering—a generalization of Wiener filtering, termed *cyclic Wiener filtering*. The idea is to jointly filter frequency-shifted, but correlated, versions of the signal as shown in Fig. 17, where the input signal  $x(t)$  is shifted in the frequency domain at multiples of the cyclic frequency  $\alpha$ , and then the shifted outputs are adaptively filtered and summed. This “spectral diversity” can greatly improve interference rejection. Gardner also shows how the performance depends on the signal’s excess bandwidth. A

FRESH DF equalizer is a DFE where the forward filter is replaced by a bank of filters whose inputs are frequency-shifted. By exploiting the spectral redundancy of modulated signals, this technique improves the DFE performance in a cyclostationary environment. Hendessi, Hafez, and Sheikh [70] show that the performance of the FRESH-DFE is superior to that of a conventional DFE.

The process of time-dependent filtering is illustrated in Fig. 18, which shows the spectrum of a SOI and that of a signal-not-of-interest (SNOI). Signals frequency shifted by the baud rate of the SOI use the opposite sidebands of the SOI to improve the contribution of the SOI in the estimated signal. The signal spectrum is shifted by the baud rate of the SOI so that the opposite sidebands line up. Redundant information in the sideband is used to improve the signal. In addition, signals frequency shifted by the baud rate of the SNOI are used to reduce the contribution of the SNOI in the estimated signal.

Greene, Reed, Yuen, and Hsia [61, 142] present the optimal time-dependent receiver (OTDR) and show it to be superior to the conventional matched-filter receiver when cyclostationary interference is present, because the OTDR exploits the statistical periodicities of the interference. The matched filter is periodic at the baud rate of the SOI, while the OTDR is periodic at the baud rate of the SOI and any other statistical periodicity of the received signal (including that of the interfering signal).

Mendoza, Reed, Hsia, and Agee [107] present two new blind adaptive filtering algorithms for interference rejection using time-dependent filtering structures that exploit cy-

clostationary signals. They show that the blind (i.e., operating without the use of an external training signal) time-dependent filtering algorithms can provide MSE and BER that are significantly lower than the MSE and BER provided by conventional time-independent adaptive filters (which are nonblind and training-sequence directed).

Nicolas and Lim [120] address the problem of transmitting digital HDTV signals in a CCI limited environment. They describe a new signal processing technique aimed at rejecting CCI from adjacent analog transmitters. The proposed scheme uses a form of joint DFE/trellis-coded modulation to combat the interference. DFE can be used in the application by exploiting the cyclostationary properties of the interference. The technique has several advantages over methods previously proposed: 1) processing is constrained to the receiver, 2) the scheme is able to make use of powerful coding schemes, 3) the scheme is adaptive, and 4) reception on conventional NTSC (National Television System Committee) receivers is not affected by this scheme.

### Nonlinear Techniques

Nonlinear interference-rejection techniques have been applied to non-SS signals as well as SS signals (see the earlier section on nonlinear techniques). The capabilities of a nonlinear filter are illustrated using the nonlinear canceler shown in Fig. 19 [118]. Given:

$$\text{a desired wave: } a \cdot \sin 2\pi f_1 t \quad (a \ll 1) \quad (6a)$$

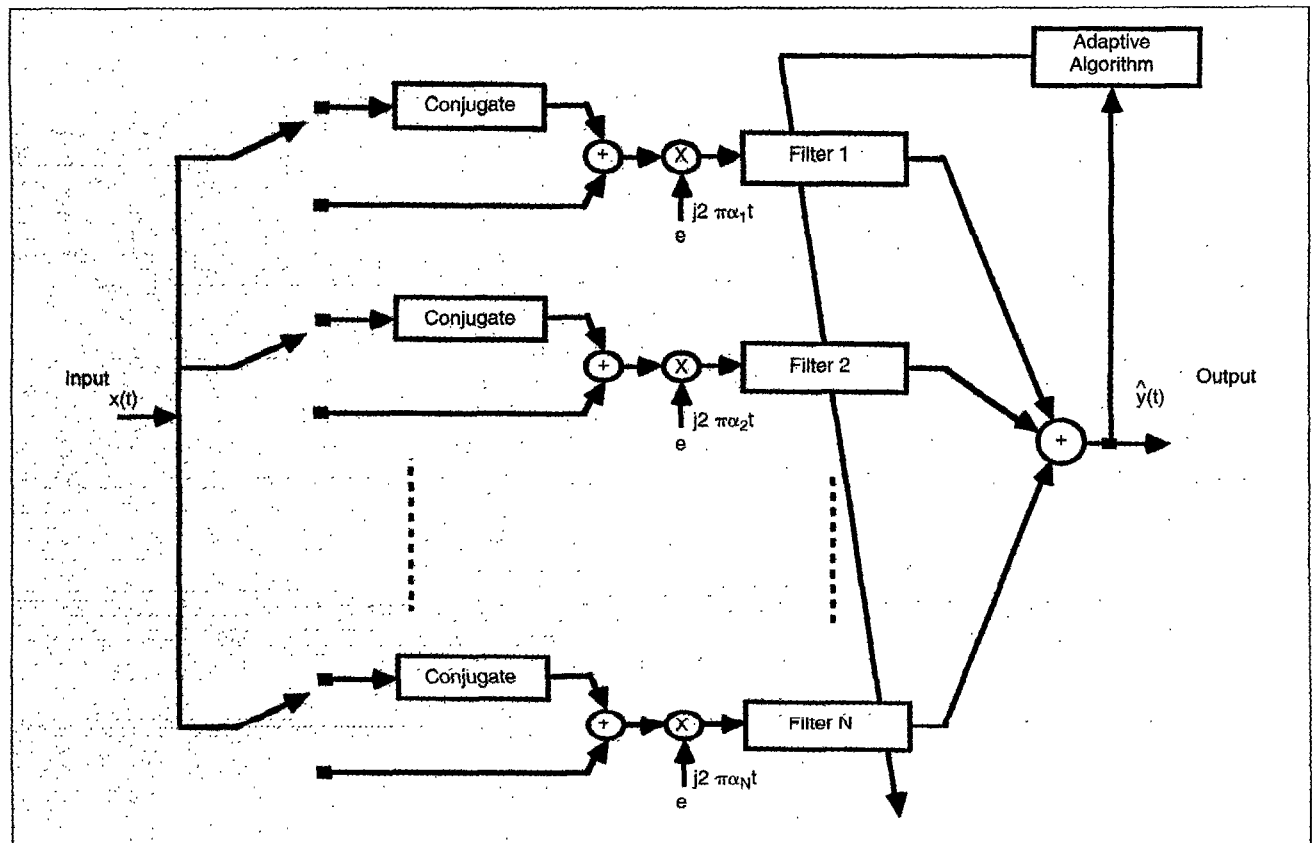

17. Optimal FREquency Shift (FRESH) filtering.

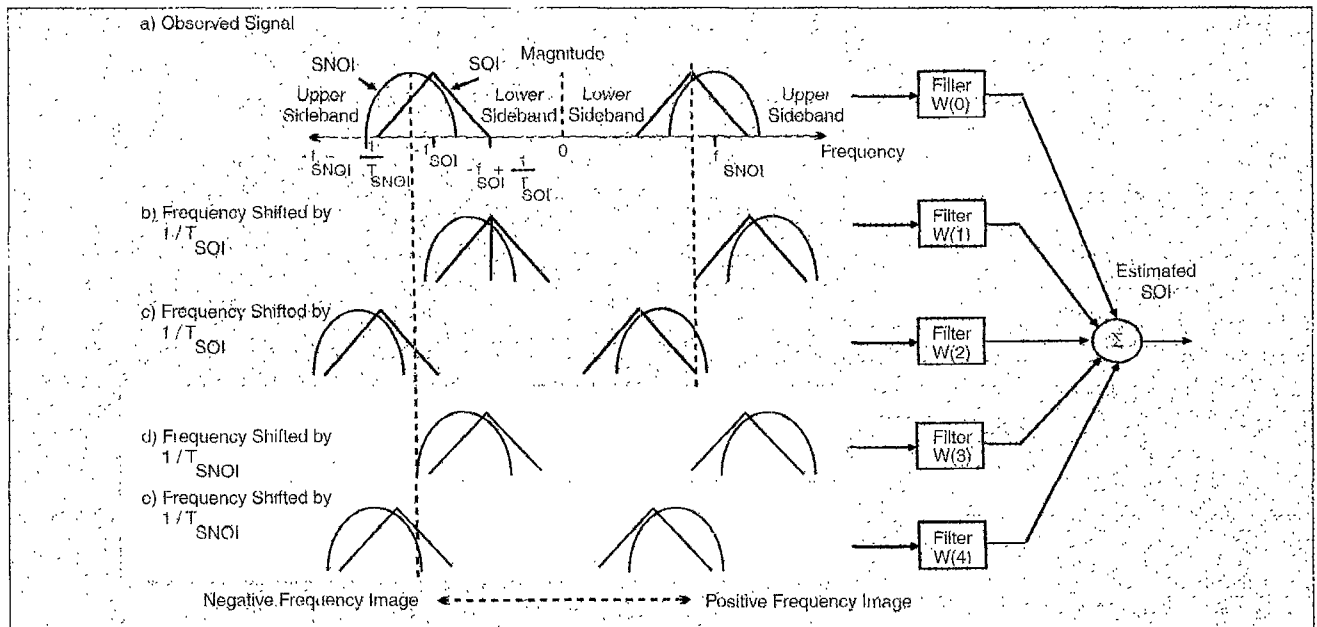

18. The process of time-dependent filtering.

$$\text{a large undesired wave: } \sin 2\pi f_2 t \quad (6b)$$

assuming no noise, the input  $x(t)$  becomes:

$$x(t) = a \cdot \sin 2\pi f_1 t + \sin 2\pi f_2 t$$

and only small signals are amplified by the expander (with cubed elements here) to become:

$$y(t) = x^3(t) \approx 2a \sin 2\pi f_1 t + \sin 2\pi f_2 t + a \cdot \sin 2\pi(2f_2 - f_1)t \quad (7)$$

If ideal amplifier automatic gain control (AGC) is assumed, the output of the canceler becomes:

$$z(t) = y(t) - x(t) = a \cdot \sin 2\pi f_1 t + a \cdot \sin 2\pi(2f_2 - f_1)t \quad (8)$$

and the desired signal is extracted. In real conditions, however, the AGC will sometimes eliminate the desired signal.

To overcome the deficiencies of the AGC, Nagayasu and Sampei [118] propose an ANLE containing the conventional ALE and a nonlinear canceler, which eliminates ACI by nonlinear processing. The intermodulated wave occurring inside the nonlinear canceler is eliminated by the bandpass filter (BPF). The results show that the ANLE can effectively eliminate an interfering wave component whose spectrum has become overlapped with a desired wave, thus giving it better interfering wave-eliminating characteristics than the ALE or the nonlinear canceler by themselves.

Maulhardt, Davis, and May [105] present techniques for designing frequency-domain nonlinear adaptive filters. These techniques make use of hierarchical memory structures that are trained to learn the appropriate transfer functions for a given signal and interference environment. Valeev and Yazovskii [162] consider a method for construction of an adaptive nonlinear converter (ANC) as a preprocessor to a

correlation receiver for improving immunity to non-Gaussian interference. The authors show how to construct the nonlinearity to maximize output SNR.

By viewing noise cancellation as an input/output identification problem, Giannakis and Dandawate [53] develop designs using third-order statistics that are insensitive to corruption of the reference signal by additive Gaussian noise of unknown covariance. As a by-product of designing linear noise cancelers, a parametric time-delay estimate is readily available, and higher-order statistics can be employed to design nonlinear cancelers of the discrete Volterra-type that maximize the output SNR.

## Other Techniques

Bar-Ness and Bunin [14] improve on a method for CCI suppression and signal separation that uses the amplitude variation of the composite signal to estimate the parasitic phase modulation impinging on the strong desired signal by the weak interference signal. This estimate is then used to cancel out the distortion of the composite signal, revealing the desired signal. In the cancellation process, initial amplitude estimates for both signals are obtained from measurements. An adaptive method is proposed that improves these estimates and, hence, results in a better cancellation of interference. In comparison with nonadaptive methods, the adaptive approach exhibits an additional 21 dB of interference suppression.

Libing, Guangguo, and Boxiu [95] examine the suppression of FM interference in QAM systems using adaptive DF filters. They provide analytic expressions and plots of symbol-error probability.

Shin and Nikias [149, 150] introduce a new higher-order statistics-based AIC to eliminate additive narrowband and wideband interferences in environments where the interference is non-Gaussian and where a reference signal, which is highly correlated with the interference, is available. The

scheme uses higher-order statistics (HOS) of the primary and reference inputs and employs a gradient-type algorithm for updating the filter coefficients. The authors demonstrate that the HOS-based adaptive algorithm performs more effectively than the second-order statistics-based adaptive algorithm not only for single and multiple NBI with/without Gaussian uncorrelated noise sources but also for wideband (AM and FM) interferences. Exploiting HOSs can lead to new blind adaptive filtering techniques and is a promising approach that could lead to new blind algorithms for interference rejection.

## Conclusion

Though finding their roots in military anti-jam research, interference-rejection techniques are of increasing interest to industry because of their applicability to commercial wireless communications. The prediction filter is one of the earliest and simplest forms of adaptive interference rejection and has been supplemented by many new interference-rejection techniques capable of rejecting interference with less distortion and under a wider variety of signal conditions.

Among SS techniques, we have surveyed advances in NBI rejection for DS systems (including adaptive notch filtering, DF, adaptive A/D conversion, and nonlinear techniques), wideband interference rejection for DS (dividing into single-user and multiuser techniques, with particular focus on CDMA interference rejection), and interference rejection for FH. Among the non-SS techniques, we have surveyed advances in interference rejection based on adaptive equalization, the CMA, neural networks (including the self-organizing feature map, feed-forward networks with backpropagation, PPs, and the RBF), spectral correlation, nonlinear techniques, and some miscellaneous techniques. Many of the techniques show promise of mitigating interference in digital wireless communications. There remains much work, however, in determining the relative merits and practicality of the newer techniques.

In regard to the future direction of interference rejection, work will now focus more on commercial signals, such as IS-95 and IEEE 802.11 WLAN SS systems, or IS-54, GSM, DECT, PACS, or IS-136 TDMA systems, where techniques will be directly applied. Research will center on specific standards as opposed to generic SS and other generic digitally modulated signal formats. Having fixed standards will also encourage research into hardware implementations of techniques that are applicable to widely acknowledged digital modulation standards (e.g., Gaussian minimum shift keying (GMSK)).

Undoubtedly, many of the MAI CDMA interference-rejection techniques will end up in hardware because of the tremendous gains in spectral capacity provided—doubling or even tripling channel capacity. The inherent spectral inefficiency of single-cell SS systems can be overcome by interference-rejection techniques, approaching and exceeding spectral capacities provided by TDMA or FDMA.

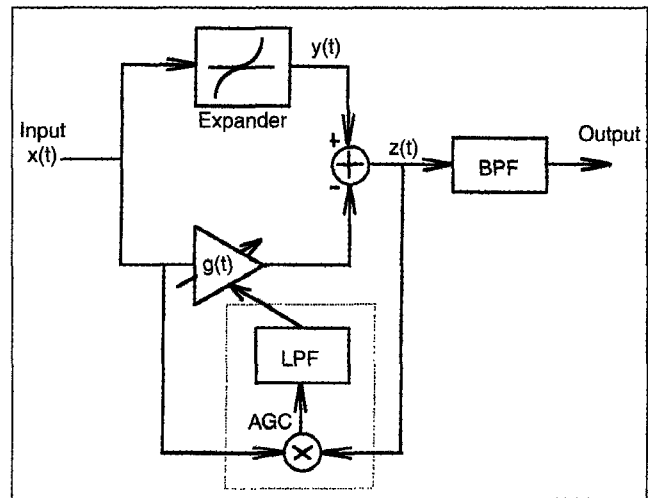

19. Configuration and spectrum of a nonlinear canceller, based on [118].

The performance of traditional notch filtering (or prediction-based filtering) approaches is being exceeded by the use of nonlinear filtering techniques (such as the RBF neural network) and time-varying filtering (such as the FRESH filter).

There is generally a lack of good blind algorithms, though decision-directed training techniques and the CMA still serve as basic, practical blind algorithms. Training techniques derived by using self-training neural networks, HOS characterization, and cyclostationary exploitation algorithms are promising, but these techniques tend to require a heavy computational load and are susceptible to degradation in dynamic channels because of the long time-bandwidth products necessary to obtain consistent statistical estimates. So far, most of the work in these promising interference-rejection techniques tends to be applied to channels that are not realistic for wireless systems. The sophistication of channel models is increasing and is providing more accurate performance predictions via simulations of real-world performance.

The analysis for interference-rejection techniques is beginning to be more complete, providing theoretical BER or FER estimates, instead of MSE (which may or may not be reflective of BER or FER). Furthermore, the analysis of interference-rejection techniques will need to include (and demonstrate) the impact on overall system capacity in order to be fully appreciated.

## Acknowledgments

We thank Mike Buehrer, Milap Majmundar, Ivan Howitt, and Francis Dominique of the MPRG for suggestions that have been incorporated throughout the article. Work partially sponsored by the Center for Wireless Technology and the Center for Transportation Research at Virginia Tech under a Research Center of Excellence project from the Federal Highway Administration.

*J.D. Laster* and *J.H. Reed* are with the Virginia Polytechnic Institute & State University's Mobile and Portable Radio Re-

search Group in the Bradley Department of Electrical Engineering in Blacksburg, Virginia. Fax: (540) 231-2968; phone: (540) 231-2964; email: j.laster@ieee.org

## References

1. B. Aazhang, B.-P. Paris, and G.C. Orsak, "Neural networks for multi-user detection in code-division multiple-access communications," *IEEE Transactions on Communications*, vol. 40, no. 7, pp. 1212-1222, July 1992.
2. M. Abdulrahman, D.D. Falconer, and A.U.H. Sheikh, "Equalization for interference cancellation in spread spectrum multiple access systems," *Proceedings VTC*, pp. 71-74, May 1992.
3. M. Abdulrahman, D.D. Falconer, and A.U.H. Sheikh, "DFE convergence for interference cancellation in SS MA systems," *VTC*, pp. 807-810, 1993.
4. Abdulrahman, Majeed; Sheikh, Asrar U.H.; Falconer, David D., "Decision feedback equalization for CDMA in indoor wireless communications," *IEEE Journal on Selected Areas in Communications*, v 12, n 4, pp. 698-706, May 1994.
5. B. G. Agee, "Solving the near-far problem: Exploitation of spatial and spectral diversity in wireless personal communication networks," *Virginia Tech's Third Symposium on Wireless Personal Communications*, p. 15-1, June 9-11, 1993.
6. F. Amoroso and J.L. Bricker, "Increasing the up-link CW interference immunity of non-coherent direct sequence pseudonoise (DSPN) reception with on-board processing," *International Journal of Satellite Communications*, vol. 11, no. 3, pp. 107-18, May-June 1993.
7. M.G. Amin, G. Venkatesan, and S. Tyler, "A new approach for interference excision in spread spectrum using time-frequency distributions," *Proceedings of the SPIE*, vol. 2563, pp. 59-68, 10-12 July 1995.
8. F. Amoroso, "Adaptive A/D converter to suppress CW interference in DSPN spread spectrum communications," *IEEE Trans. Commun.*, vol. COM-31, pp. 1117-1123, October 1983.
9. F. Amoroso, "Performance of the adaptive A/D converter in combined CW and Gaussian interference," *MILCOM*, 1984.
10. F. Amoroso and J.L. Bricker, "Performance of the adaptive A/D converter in combined CW and Gaussian interference," *IEEE Trans. Commun.*, vol. COM-34, pp. 209-213, March 1986.
11. F. Amoroso, "Adaptive A/D converter to suppress co-channel constant envelope interference in a mobile digital link," *Telecommunication Systems - Modeling, Analysis, Design and Management*, vol. 2, no. 1, pp. 109-19, 1993.
12. V. Aue and J.H. Reed, "An interference robust CDMA demodulator that uses spectral correlation properties," *IEEE Vehicular Technology Conference*, pp. 563-567, 1994.
13. V. Aue and J.H. Reed, "CDMA demodulation and interference rejection using an optimal time-dependent filter," unpublished master's thesis, Mobile & Portable Radio Research Group, Bradley Department of Electrical Engineering, Virginia Polytechnic Institute and State University, February 1994.
14. Y. Bar-Ness and B.H. Bunin, "Adaptive co-channel interference cancellation and signal separation method," *IEEE International Conference on Communications - ICC'89*, pp. 825-830, 11-14 June 1989.
15. Y. Bar-Ness, Z. Siveski, and D.W. Chen, "Bootstrapped decorrelating algorithm for adaptive interference cancellation in synchronous CDMA communications systems," *IEEE Third International Symposium on Spread Spectrum Techniques & Applications*, pp. 162-166, July 4-6, 1994.
16. N.J. Bershad, "Error probabilities for DS spread-spectrum systems using an ALE for narrow-band interference rejection," *IEEE Transactions on Communications*, vol. 36, no. 5, pp. 588-95, May 1988.
17. R. Bijjani and P.K. Das, "Rejection of narrowband interference in PN spread-spectrum systems using neural networks," *GLOBECOM '90: IEEE Global Telecommunications Conference and Exhibition. 'Communications: Connecting the Future'*, vol. 2, pp. 1037-41, 2-5 Dec. 1990.
18. F.A. Bishop and R.S. Leahy, "Enhancement of frequency hopped signals by convergence bandwidth discrimination," *1985 IEEE Military Communications Conference: MILCOM '85. Conference Record*, vol. 2, pp. 334-8, 20-23 Oct. 1985.
19. J.L. Bricker, "Mathematical methodology for analysis of the adaptive A/D converter in combined CW and Gaussian interference," *MILCOM '84*, pp. 545-551, 1984.
20. M. Buchrer and B.D. Woerner, "A survey of multiuser receivers for cellular CDMA," paper yet to be published, Mobile & Portable Radio Research Group, Bradley Department of Electrical Engineering, Virginia Polytechnic Institute and State University, March 1996.
21. K.V. Cai, "Optimization of 2-bit A/D adaptive converter performance in CW interference," *MILCOM '84*, pp. 552-558, 1984.
22. S. Chen, B. Mulgrew, and S. McLaughlin, "Adaptive Bayesian decision feedback equalizer based on a radial basis function network," *SUPERCOMM/ICC '92*, pp. 343.3, 1992.
23. S. Chen, S. McLaughlin and B. Mulgrew, "Complex-valued radial basis function network, Part II: Application to digital communications channel equalisation," *Signal Processing - An International Journal*, vol. 36, no. 2, pp. 175-188, March 1994.
24. I. Cha and S.A. Kassam, "Interference cancellation using radial basis function networks," *IEEE Sixth SP Workshop on Statistical Signal and Array Processing Conference Proceedings*, pp. 221-4, 7-9 Oct. 1992.
25. I. Cha and S.A. Kassam, "Interference cancellation using radial basis function networks," *Signal Processing*, vol. 47, no. 3, pp. 247-68, December 1995.
26. Chihkang Chen, *Spectral Correlation Characterization of Modulated Signals with Application to Signal Detection and Source Location*, Ph.D. dissertation, Department of Electrical and Computer Engineering, University of California at Davis, 1988.
27. S. Chen and B. Mulgrew, "Overcoming co-channel interference using an adaptive radial basis function equalizer," *Signal Processing*, vol. 28, pp. 91-107, 1992.
28. S. Chen, S. McLaughlin, B. Mulgrew, P.M. Grant, "Adaptive Bayesian decision feedback equalizer incorporating co-channel interference compensation," *ICC '94*, pp. 530-533, 1994.
29. M.E. Davis and L.B. Milstein, "Anti-jamming properties of a DS-CDMA equalization filter," *Proceedings of the 12th Annual IEEE Military Communications Conference*, vol. 3, p. 1008-1012, 1993.
30. G. Dimos and T. Upadhyay, "Low-cost solution to narrowband GPS interference problem," *IEEE Proceedings of the National Aerospace and Electronics Conference*, pp. 145-153, 1995.
31. J.F. Doherty, "Linearly constrained interference rejection for improved spread spectrum performance," *SUPERCOMM/ICC '92. Discovering a New World of Communications*, vol. 3, pp. 1257-61, 14-18 June 1992.
32. Z.S. Dobrosavljevic and M.L. Dukic, "On narrowband interference suppression using DFB filter in DSSS systems under impulsive channel conditions," *IEEE Third International Symposium on Spread Spectrum Techniques & Applications*, pp. 530-535, July 4-6, 1994.
33. J.F. Doherty, "An adaptive technique for improving spread spectrum interference rejection," *Proceedings. RF Expo EAST*, pp. 385-7, 29-31 October 1991.
34. J.F. Doherty, "A constrained LMS algorithm for interference rejection," *MILCOM '92 - 'Communications - Fusing Command, Control and Intelligence' Conference Record*, vol. 2, pp. 696-700, 11-14 October 1992.
35. J.F. Doherty, "Direct sequence spread spectrum interference rejection using vector space projection techniques," *Virginia Tech's Third Symposium on Wireless Personal Communications. Proceedings*, pp. 9/1-9, June 1993.
36. J.H. Doherty, "Linearly constrained direct-sequence spread-spectrum interference rejection," *IEEE Transactions on Communications*, no. 2/3/4, pp. 865-872 Feb/Mar/Apr 1994.
37. F. Dominique and P. Petrus, "Spectral redundancy exploitation in narrow band interference rejection for a PN-BPSK system," *MILCOM '94*, vol. 2, pp. 405-409, 1994.

38. F. Dominique and T.P. Subramanian, "Combined self-organising feature map - LMS adaptive filter for digital co-channel interference suppression," *Electronics Letters*, vol. 23, no. 3, pp. 168-9, 1 February 1996.
39. M.L. Dukic, Z.D. Stojanovic, and I.S. Stojanovic, "Performance of direct-sequence spread-spectrum receiver using decision feedback and transversal filters for combating narrowband interference," *IEEE Journal on Selected Areas in Communications*, vol. 8, no. 5, pp. 907-14, June 1990.
40. A. Dual-Hallen, "Decorrelating decision-feedback multiuser detector for synchronous code-division multiple-access channel," *IEEE Transactions on Communications*, vol. 41, no. 2, pp. 285-290, February 1993.
41. A. Duel-Hallen, J. Holtzman, and Z. Zvonar, "Multiuser detection for CDMA systems," *IEEE Personal Communications*, pp. 46-58, April 1995.
42. M.L. Dukic, Z.D. Stojanovic, I.S. Stojanovic, "A new direct sequence spread spectrum receiver using decision feedback and transversal filters for rejection of the narrow-band interference and errors caused by signal distortion," *MELECON '89: Mediterranean Electrotechnical Conference Proceedings. Integrating Research, Industry and Education in Energy and Communication Engineering*, pp. 395-8, 11-13 April 1989.
43. M.L. Dukic, D.O. Cuberovic, Z.D. Stojanovic, and I.S. Stojanovic, "Performance analysis of DS spread-spectrum receiver using decision feedback and transversal interference suppression filters under multiple narrow-band interference," *Communication Systems: Towards Global Integration. Singapore ICCS '90. Conference Proceedings*, vol. 2, pp. 25-21/1-5, 5-9 Nov. 1990.
44. M.L. Dukic, Z.S. Dobrosavljevic, Z.K. Stojanovic, and I.S. Stojanovic, "Rejection of narrowband interference in DSSS Systems using two-stage decision feedback filters," *IEEE Third International Symposium on Spread Spectrum Techniques & Applications*, pp. 526-529, July 4-6, 1994.
45. E.R. Ferrara, Jr., "A method for canceling interference from a constant envelope signal," *IEEE Transactions on Acoustics, Speech and Signal Processing*, vol. ASSP-33, no. 1, pp. 316-19, February 1985.
46. K. Fukawa and H. Suzuki, "Blind interference canceling equalizer for mobile radio communications," *IEICE Transactions on Communications*, v E77-B, n 5, pp. 580-588, May 1994.
47. W.A. Gardner and W.A. Brown, "Frequency-shift filtering theory for adaptive co-channel interference removal," *Twenty-Third Asilomar Conference on Signals, Systems and Computers*, vol. 2, pp. 562-7, November 1989.
48. W.A. Gardner and S. Venkataraman, "Performance of optimum and adaptive frequency-shift filters for cochannel interference and fading," *Conference Record. Twenty-Fourth Asilomar Conference on Signals, Systems and Computers*, vol. 1, pp. 242-7, 5-7 Nov. 1990.
49. L. Garth, R. Vijayan, and H.V. Poor, "A new approach to interference suppression in spread-spectrum systems," *Military Communications in a Changing World MILCOM, 91. Conference Record*, vol. 1, pp. 375-9, 4-7 November 1991.
50. L.M. Garth and H.V. Poor, "Narrowband interference suppression in impulsive channels," *IEEE Transactions on Aerospace and Electronic Systems*, vol. 28, no. 1, pp. 15-34, January 1992.
51. W.A. Gardner, "Cyclic Wiener filtering: theory and method," *IEEE Transactions on Communications*, vol. 41, no. 1, pp. 151-163, January, 1993.
52. J. Gevargiz, P.K. Das, and L.B. Milstein, "Adaptive narrow-band interference rejection in a DS spread-spectrum intercept receiver using transform domain signal processing techniques," *IEEE Transactions on Communications*, vol. 37, no. 12, pp. 1359-66, December 1989.
53. G.B. Giannakis and A.V. Dandawate, "Linear and non-linear adaptive noise cancelers," *ICASSP 90. 1990 International Conference on Acoustics, Speech and Signal Processing*, vol. 3, pp. 1373-6, 3-6 April 1990.
54. S.G. Glisic and M.D. Pajkovic, "Rejection of FH signal in DS spread spectrum system using complex adaptive filtering," *MILCOM 90. A New Era. 1990 IEEE Military Communications Conference. Conference Record*, vol. 1, pp. 349-53, October 1990.
55. S.G. Glisic and M.D. Pajkovic, "Rejection of FHMA signal in DS spread spectrum system using complex adaptive filtering," *Military Communications in a Changing World MILCOM, 91. Conference Record*, vol. 1, pp. 365-9, 4-7 Nov. 1991.
56. S. Glisic, "BER and Interference suppression filter misadjustment analysis for DS/CDMA receiver operating in the presence of FH interference," *MILCOM '93*, pp. 15M.2, 1993.
57. A.M.J. Goiser and M.K. Sust, "Adaptive interference rejection in a digital direct sequence spread spectrum receiver," *IEEE Military Communications Conference - MILCOM '89. Part 2*, pp. 514-520, 1989.
58. A.M.J. Goiser and M.K. Sust, "Adaptive interference rejection for non-coherent digital direct sequence spread spectrum receivers," *GLOBECOM '90: IEEE Global Telecommunications Conference and Exhibition. 'Communications: Connecting the Future,'* vol. 1, pp. 285-90, 2-5 Dec. 1990.
59. R.P. Gooch and B. Daellenbach, "Prevention of interference capture in a blind (CMA-based) adaptive receive filter," *Twenty-Third Asilomar Conference on Signals, Systems and Computers*, vol. 2, pp. 898-902, November 1989.
60. P.M. Grant, S. Mowbray, and R.D. Pringle, "Multipath and co-channel CDMA interference cancellation," *IEEE Second International Symposium on Spread Spectrum Techniques & Applications*, November 29 - December 2, 1992, p. 5.1.
61. C.D. Greene, J. H. Reed, Yuen, and T. C Hsia, "An optimal receiver using a time -dependent adaptive filter," *MILCOM 1989*, 1989.
62. Zengjun Xiang; Guangguo Bi, "Lattice polynomial perceptron based M-QAM digital communication reception systems," *ICCT '92 - Proceedings of the 1992 Int'l Conf. on Communication Technology*, vol. 2, pp. 27.05/1-5, 1992.
63. Zengjun Xiang; Guangguo Bi, "New fractionally spaced recursive polynomials perceptron model for adaptive M-QAM digital mobile radio reception," *Electronics Letters*, vol. 28, no. 22, pp. 2049-51, 22 Oct. 1992.
64. R.F. Guertin, "Narrowband interference suppression in a spread-spectrum system using vector space methods," *MILCOM '89*, 28.5.1-6, pp. 508-513, 1989.
65. T.A. Gulliver, "Order statistics diversity combining in worst case noise and multitone jamming," *MILCOM 91*, vol. 1, pp. 385-389, November 1991.
66. A. Haimovich and A. Vadhri, "Rejection of narrow-band interferences in PN spread spectrum systems using an eigenvanalysis approach," *MILCOM '94*, vol. 3, pp. 1007-1011.
67. S. Haykin, *Adaptive Filter Theory* (2nd ed.), Prentice-Hall: Englewood Cliffs, NJ, 1991.
68. S. Haykin, "Neural networks expand SP's horizons," *IEEE Signal Processing Magazine*, pp. 24-49, March 1996.
69. Y. He, S.-F. Lei, P. Das, and G.J. Saulnier, "Suppression of narrowband jammers in a DS spread spectrum receiver using modified adaptive filtering technique," *GLOBECOM '88. IEEE Global Telecommunications Conference and Exhibition - Communications for the Information Age. Conference Record*, vol. 1, pp. 540-5, 28 December 1988.
70. F. Hendessi, H.M. Hafez, and A.U.H. Sheikh, "Structure and performance of FRESH-decision feedback equalizer in the presence of adjacent channel interference," *Proceedings of the 43rd IEEE Vehicular Technology Conference*, pp. 641-644, 1993.
71. J.H. Higbie, "Adaptive nonlinear suppression of interference," *MILCOM 88: 21st Century Military Communications - What's Possible?*, (San Diego, CA), pp. 381-389, 1988.
72. M.L. Honig, U. Madhow, and S. Verdú, "Blind adaptive multiuser detection," *IEEE Trans. on Information Theory*, vol. 41, no. 4, pp. 944-960, July 1995.
73. R.D. Holley and J.H. Reed, "Time dependent adaptive filters for interference cancellation in CDMA systems," *Workshop on Cyclostationarity SP*, Monterey, August 1994.
74. M.L. Honig, U. Madhow, and S. Verdú, "Blind adaptive interference suppression for near-far resistant CDMA," *GLOBECOM '94*, pp. 379-38, 1994.
75. M.L. Honig, "Orthogonal anchored blind interference suppression using the Sato cost criterion," *Proceedings of the 1995 IEEE Int'l Symposium on Information Theory*, pp. 314, 1995.
76. I. Howitt, J.H. Reed, V. Vemuri, and T.C. Hsia, "Recent Developments in Applying Neural Nets to Equalization and Interference Rejection," *Vir-*

- ginia Tech's Third Symposium on Wireless Personal Communications. Proceedings, June 1993.
77. I. Howitt, J.H. Reed, R. Vemuri, T.C. Hsia, "RBF growing algorithm applied to the equalization and co-channel interference rejection problem," *IEEE World Congress on Computational Intelligence / International Conference on Neural Networks*, Orlando, Florida, June 26 - July 2, 1994.
78. I. Howitt, *Radial Basis Function Methodology for Use in Digital Communications*, Ph.D. Dissertation, University of California, Davis, 1995.
79. I. Howitt, personal conversation, Mobile & Portable Radio Research Group, Virginia Tech, March 1996.
80. R.A. Iltis, "Interference cancellation for enhanced detection of frequency-hopped signals," *ICASSP 86 (Toyko)*, vol. 2, pp. 973-976, April 1986.
81. R.A. Iltis, "A GLRT-based SS receiver for joint channel estimation and interference suppression," *IEEE Transactions on Communications*, vol. 37, no. 3, pp. 277-288, March 1989.
82. R. Iltis, J. Ritcey and L.B. Milstein, "Interference rejection in FFH systems using least-squares estimation techniques," *IEEE Transactions on Communications*, vol. 38, no. 12, pp. 2174-83, December 1990.
83. W. Jacklin, J. Grimm, and D. Ucci, "The simulation of a two-dimensional SS system with locally optimal processing," *MILCOM '93*, pp. 9.6, 1993.
84. E.G. Kanterakis, "A novel technique for narrowband /broadband interference excision in DSSS communications," *MILCOM '94*, vol. 2, pp. 628-632, 1994.
85. T. Kasparis, M. Georgiopoulos, and E. Payne, "Non-linear filtering techniques for narrow-band interference rejection in DSSS systems," *MILCOM '91*, pp. 17.1, 1991.
86. D.J. Kennedy and E.K. Koh, "Frequency-reuse interference in TDMA/QPSK satellite systems," *Fifth International Conference on Digital Satellite Communications*, (Genoa, Italy), pp. 99-107, March 23-26, 1981.
87. R. Kohno, "Pseudo-noise sequences and interference cancellation techniques for spread spectrum systems-spread spectrum theory and techniques in Japan," *IEICE Transactions*, vol. E74, no. 5, pp. 1083-92, May 1991.
88. A. Krieger, "An adaptive algorithm for interference suppression in SS communications systems," *1990 24th Asilomar Conference on Signals, Systems, and Computers*, vol. 1, pp. 373-378, 1990.
89. D.M. Krinsky, A.H. Haddad, and C.C. Lee, "An adaptive DSSS receiver for burst type interference," *IEEE JSAC*, vol. 13, no. 1, pp. 59-70, January 1995.
90. N. Kurita, I. Sasame, and S. Mori, "Suppression of narrowband interference in FFH systems by hardlimited combining receiver using transversal filters," *1992 IEEE Int'l Conf. on Selected Topics in Wireless Communications*, pp. 445-48, June 25-26, 1992.
91. O.W. Kwon, C.K. Un, and J.C. Lee, "Performance of constant modulus adaptive digital filters for interference cancellation," *Signal Processing*, vol. 26, no. 2, pp. 185-96, February 1992.
92. J.H. Lee and C.W. Lee, "Adaptive filters for suppressing irregular hostile jamming in direct sequence spread-spectrum system," *MILCOM 87: 1987 IEEE Military Communications Conference. 'Crisis Communications: The Promise and Reality'*, *Conference Record*, vol. 1, pp. 118-22, 19-22 October 1987.
93. B. Lee and J. Essman, "On a new scheme of reference signal generating method for interference suppression in DSSS systems," *MILCOM '90*, pp. 36.6, 1990.
94. E.K.B. Lee, "Rapid converging adaptive interference suppression for DS CDMA systems," *GLOBECOM '93*, pp. 1683-1687, 1993.
95. W. Libing, B. Guangguo, and W. Boxiu, "Suppression of FM interference in QAM systems using adaptive decision-feedback filters," *China 1991 International Conference on Circuits and Systems. Conference Proceedings*, vol. 1, pp. 161-3, 16-17 June 1991.
96. N.W.K. Lo, D.D. Falconer, A.U.H. Sheikh, "Adaptive equalization techniques for multipath fading and co-channel interference," *VTC 1993*, pp. 653-656, 1993.
97. N.W.K. Lo, D.D. Falconer, and A.U.H. Sheikh, "Adaptive equalization for a multipath fading environment with interference and noise," *VTC 1994*, pp. 252-256, 1994.
98. R. Lupas and S. Verdú, "Linear multiuser detectors for synchronous code-division multiple-access channel," *IEEE Trans. Commun.*, vol. IT-32, no. 1, pp. 85-96, January 1989.
99. U. Madhow and M.L. Honig, "Minimum mean squared error interference suppression for direct-sequence spread-spectrum code-division multiple-access," *ICUPC '92 Proceedings*, pp. 10.04/1-5, 29 Sept.-1 Oct. 1992.
100. U. Madhow and M. Honig, "Error probability and near-far resistance of minimum mean squared error interference suppression schemes for CDMA," *GLOBECOM '92. Communication for Global Users. IEEE Global Telecommunications Conference. Conference Record*, vol. 3, pp. 1339-43, 6-9 December 1992.
101. U. Madhow and M. Honig, "MMSE Interference Suppression for DSSS CDMA," *IEEE Transactions on Communications*, vol. 42, no. 12, pp. 3178-3188, December 1994.
102. M. Majmundar, "Adaptive single-user receivers for DS CDMA systems," unpublished master's thesis, Mobile & Portable Radio Research Group, Bradley Department of Electrical Engineering, Virginia Polytechnic Institute and State University, March 1996.
103. A. Mammela, "The performance of adaptive interference suppression filters used in PN spread-spectrum systems," *EUROCON 88: 8th European Conference on Electrotechnics. Conference Proceedings on Area Communication*, pp. 126-9, 13-17 June 1988.
104. N.B. Mandayam and B. Aazhang, "Adaptive multiuser interference rejection algorithm for DS-CDMA," *Proceedings of the 1994 IEEE Int'l Symposium on Information Theory*, 1994.
105. M. Maulhardt, A.M. Davis, and J. May, "Numerical design of nonlinear adaptive filters," *ICASSP 86 Proceedings. IEEE-IECEJ-ASJ International Conference on Acoustics, Speech and Signal Processing*, vol. 3, pp. 2131-4, 7-11 April 1986.
106. M. Medley, G. Saulnier, and P. Das, "Applications of the wavelet transform in SS communications systems," *Proceedings of the SPIE - The Int'l Society for Optical Engineering*, vol. 2242, pp. 54-68, 1994.
107. R. Mendoza, J.H. Reed, T.C. Hsia, and B.G. Agee, "Interference rejection using the time-dependent constant modulus algorithm (CMA) and the hybrid CMA/spectral correlation discriminator," *IEEE Transactions on Signal Processing*, vol. 39, no. 9, September 1991.
108. L.B. Milstein, "Interference rejection techniques in spread spectrum communications," *Proceedings of the IEEE*, vol. 76, no. 6, June 1988.
109. L.B. Milstein and J. Wang, "Interference suppression for CDMA overlays of narrowband waveforms," *IEEE Third International Symposium on Spread Spectrum Techniques & Applications*, pp. 61-68, July 4-6, 1994.
110. S.L. Miller, "An adaptive direct-sequence code-division multiple-access receiver for multiuser interference rejection," *IEEE Trans. on Comm.*, vol. 43, no. 2/3/4, February/March/April 1995.
111. U. Mitra and H.V. Poor, "Neural network techniques for adaptive multiuser demodulation," *IEEE JSAC*, vol. 12, no. 9, pp. 1460-1470, December 1994.
112. M. Miyagi, T. Ogawa, I. Sasase, and S. Mori, "Suppression of CW interference and filtered noise in QPRS systems using decision-feedback filters," *ICASSP 90. 1990 International Conference on Acoustics, Speech and Signal Processing*, vol. 3, pp. 1703-6, 3-6 April 1990.
113. P.N. Monogioudis, R. Tafazolli, and B.G. Evans, "Linear adaptive fractionally spaced equalization of CDMA multiple-access interference," *Electronics Letters*, vol. 29, no. 21, pp. 1823-5, 14 Oct. 1993.
114. P.N. Monogioudis, R. Tafazolli, and B.G. Evans, "LFSE interference cancellation in CDMA systems," *ICC '94*, pp. 1160-1163, 1994.
115. A.M. Monk, M. Davis, L.B. Milstein, and C.W. Helstrom, "A noiseless-whitening approach to multiple access noise rejection -Part I: Theory and Background," *IEEE Journal on Selected Areas of Communications*, vol. 12, no. 5, pp. 817-827, June 1994.
116. R.S. Mowbray, R.D. Pringle, and P.M. Grant, "Increased CDMA system capacity through adaptive cochannel interference regeneration and can-



- cellation," *IEE Proceedings I (Communications, Speech and Vision)*, vol. 139, no. 5, pp. 515-24, October 1992.
117. B. Mulgrew, "Applying radial basis functions," *IEEE Signal Processing Magazine*, pp. 50-62, March 1996.
118. T. Nagayasu and S. Sampei, "Elimination of adjacent channel interference via nonlinear filters," *Electronics and Communications in Japan, Part I: Communications*, vol. 77, no. 5, pp. 23-32, 1994.
119. R.S. Nelson and T. Kasparis, "Digital processing for non-stationary narrow-band interference suppression in fading channels," *Proceedings of SOUTHEASTCON '94*, pp. 408-12 1994.
120. J. J. Nicolas and J. S. Lim, "Equalization and interference rejection for the terrestrial broadcast of digital HDTV," Research Laboratory of Electronics, MIT, 1993.
121. P. Nigier and P. Vandamme, "Performance of equalization techniques in a radio interference environment," *SUPERCOMM /ICC '90*, pp. 307.6, 1990.
122. R.C. North, R.A. Axford, and J.R. Zeidler, "The performance of adaptive equalization for digital communication systems corrupted by interference," *Asilomar 1993*, vol. 2, pp. 1548-1554, 1993.
123. T. Ogawa, I. Sasase, and S. Mori, "Suppression of CW interference and colored noise in QPSK system using decision-feedback filters," *Transactions of the Institute of Electronics, Information and Communication Engineers E*, vol. E72, no. 7, pp. 804-10, July 1989.
124. T. Ogawa, I. Sasase, and S. Mori, "Suppression of narrow-band interference and multipath by spread-spectrum receiver using decision-feedback filters," *IEEE Pacific Rim Conference on Communications, Computers and Signal Processing*, vol. 2, pp. 673-6, 9-10 May 1991.
125. C.N. Pateros and G.J. Saulnier, "Adaptive correlator receiver performance in direct sequence spread spectrum communication," *MILCOM '92 - 'Communications - Fusing Command, Control and Intelligence' Conference Record*, vol. 2, pp. 427-31, 11-14 October 1992.
126. C.N. Pateros and G.J. Saulnier, "Interference suppression and multipath mitigation using an adaptive correlator direct sequence spread spectrum receiver," *SUPERCOMM/ICC '92. Discovering a New World of Communications*, vol. 2, pp. 662-6, 14-18 June 1992.
127. P. Patel and J. Holtzman, "Analysis of a simple successive interference cancellation scheme in a DS/CDMA system," *IEEE Journal on Selected Areas of Communications*, vol. 12, no. 5, pp. 796-807, June 1994.
128. M. Peng, C.L. Nikias, and J.G. Proakis, "Adaptive equalization for PAM and QAM signals with neural networks," *Twenty-Fifth Asilomar Conference on Signals, Systems, and Computers*, pp. 496-500, 1991.
129. F.J. Pergal, "Adaptive threshold A/D conversion techniques for interference rejection in DSPN receiver applications," in *IEEE Military Communications Conf.*, pp. 4.7.1-4.7.7, October 1987.
130. B.R. Petersen and D.D. Falconer, "Suppression of adjacent-channel, cochannel, and intersymbol interference by equalizers and linear combiners," *IEEE Transactions on Communications*, vol. 42, no. 12, pp. 3109-3118, December 1994.
131. H.V. Poor and L.A. Rusch, "Narrowband interference suppression in spread spectrum CDMA," *IEEE Personal Communications Magazine*, third quarter, pp. 14-27, 1994.
132. H.V. Poor, "Adaptivity in multiple-access communications," *Proceedings of the 34th IEEE Conf. on Decision and Control*, vol. 1, pp. 835-40, 13-15 December 1995.
133. R.S. Mowbray, R.D. Pringle, and P.M. Grant, "Adaptive CDMA co-channel interference cancellation," *Signal Processing VI - Theories and Applications. Proceedings of EUSIPCO-92, Sixth European Signal Processing Conference*, vol. 3, pp. 1591-4, 24-27 August 1992.
134. Proakis, J.G., *Digital Communications* (3rd ed.), New York: McGraw-Hill, Inc., pp. 196, 1995.
135. M.B. Pursley, "The role of spread-spectrum in packet radio networks," *Proceedings of the IEEE*, vol. 75, no. 1, pp. 116-134, January 1987.
136. K. Raivio, O. Simula, and J. Henriksson, "Improving design feedback equaliser performance using neural networks," *Electronic Letters*, vol. 27, no. 23, pp. 2151-2153, 7 Nov. 1991.
137. P.B. Rapajic and B.S. Vucetic, "Linear adaptive fractionally spaced single user receiver for asynchronous CDMA systems," *Proceedings of the 1993 IEEE International Symposium on Information Theory*, p. 45, 1993.
138. P.B. Rapajic and B.S. Vucetic, "Adaptive receiver structures for asynchronous CDMA systems," *IEEE Journal on Selected Areas of Communications*, vol. 12, no. 4, pp. 685-697, May 1994.
139. P.B. Rapajic and B.S. Vucetic, "Linear adaptive transmitter-receiver structures for asynchronous CDMA systems," *European Transactions on Telecommunications*, vol. 6, no. 1, pp. 21-27, January-February 1995.
140. J.H. Reed and T.C. Hsia, "The performance of time-dependent adaptive filters for interference rejection," *IEEE Transactions on Acoustics, Speech, and Signal Processing*, vol. 38, no. 8, August 1990.
141. J.H. Reed and B. Agee, "A technique for instantaneous tracking of frequency agile signals in the presence of spectrally correlated interference," *1992 Asilomar Conference on Signals, Systems, and Computers*, 1992.
142. J.H. Reed, N.M. Yuen, and T. C Hsia, "An optimal receiver using a time-dependent adaptive filter," *IEEE Transactions on Communications*, vol. 43, no. 2/3/4, pp. 187-190, February/March/April 1995.
143. M.J. Rude and L.J. Griffiths, "An untrained, fractionally-spaced equalizer for co-channel interference environments," *Twenty-Fourth Asilomar Conference on Signals, Systems and Computers*, vol. 1, pp. 468-72, 5-7 November 1990.
144. L.A. Rusch and H.V. Poor, "Narrowband interference suppression in CDMA SS communications," *IEEE Trans. on Comm.*, vol. 42, no. 2, part 3, pp. 1969-1979, April 1994.
145. D. Ruth and M. Wickert, "A time varying transform domain excision filter for interference rejection in DSSS," *MILCOM '92*, pp. 38.3, 1992.
146. E.H. Satorius, S. Krishnan, X. Yu, L.J. Griffiths, I.S. Reed, and T. Truong, "Suppression of narrowband interference via single channel adaptive preprocessing," *Twenty-Second Asilomar Conference on Signals, Systems and Computers*, vol. 1, pp. 270-3, November 1988.
147. D.L. Schilling, G. R. Lomp, and J. Garodnick, "Broadband-CDMA overlay," *Proceedings of the 43rd IEEE Vehicular Technology Conference*, pp. 452-455, 1993.
148. B. Shah and G.J. Saulnier, "Adaptive jammer suppression using decision feedback in a spread-spectrum receiver," *MILCOM 88. 21st Century Military Communications -What's Possible? Conference Record. 1988 IEEE Military Communications Conference*, vol. 3, pp. 989-95, 23-26 October 1988.
149. D.C. Shin and C.L. Nikias, "Adaptive noise canceler for narrow-band/wideband interferences using higher-order statistics," *1993 IEEE International Conference on Acoustics, Speech and Signal Processing*, v 3, pp. 111.364-366, 1993.
150. D.C. Shin and C.L. Nikias, "Adaptive interference canceler for narrow-band and wideband interferences using higher-order statistics," *IEEE Transactions on Signal Processing*, vol. 42, no. 10, pp. 2715-2728, October 1994.
151. Z. Siveski, Y. Bar-Ness, and D.W. Chen, "Error performance of synchronous multiuser CDMA detector with multidimensional adaptive canceler," *European Transactions on Telecommunications*, vol. 5, no. 6, pp. 737/719-78/724, November-December 1994.
152. Z.D. Stojanovic, M.L. Dukic, I.S. Stojanovic, "A new method for the narrow-band interference rejection in the direct sequence spread-spectrum systems using transversal filters," *Proceedings of MELECON '87: Mediterranean Electrotechnical Conference and 34th Congress on Electronics Joint Conference*, pp. 149-52, 24-26 March 1987.
153. E.G. Ström and S.L. Miller, "Optimum complexity reduction of minimum mean square error DS-SS receivers," *Proceedings of IEEE VTC*, vol. 1, pp. 568-72, 1994.
154. F. Takawira and L.B. Milstein, "Narrowband interference rejection in PN spread spectrum communications systems using decision feedback filters," *MILCOM '86*, vol. 2, pp. 20.4/1-5, October 1986.
155. M. Tahernezhad and L. Zhu, "Performance evaluation of LMS-based adaptive suppression schemes in asynchronous CDMA," *Int. J. Electronics*, vol. 79, no. 5, pp. 541-550, 1995.
156. M.V. Tazebay and A.N. Akansu, "A smart time-frequency exciser for SS communications," *ICASSP '95*, vol. 2, pp. 1209, 1995.

157. S. Theodoridis, N. Kalouptsidis, J. Proakis, and G. Koyas, "Interference rejection in PN SS systems with LS linear phase FIR filters," *IEEE Transactions on Communications*, vol. 37, no. 9, pp. 991-994, September 1989.
158. G. W. Travis and H. F. Lenzing, "Shipboard HF interference: problems and mitigation," *MILCOM '89: Bridging the Gap. Interoperability, Survivability, Security. Conference Record*, vol. 1, pp. 106-10, October 1989.
159. J.R. Treichler and B.G. Agee, "A new approach to multipath correction of constant modulus signals," *IEEE Trans. on Acoustics, Speech, and Signal Processing*, vol. ASSP-31, pp. 459-472, April 1983.
160. J.R. Treichler and M.G. Larimore, "New Processing Techniques based on the constant modulus adaptive algorithm," *T-ASSP*, vol. 33, no. 2, pp. 420-431, April 1985.
161. J. Treichler and M.G. Larimore, "Constant modulus algorithm based techniques for adaptive interference rejection," *MILCOM '86*, pp. 47.3, 1986.
162. V.G. Valeev and A.A. Yazovskii, "Adaptive nonlinear converters for suppression of non-Gaussian interference," *Radioelectronics and Communication Systems*, vol. 30, no. 8, pp. 60-3, 1987.
163. S. Verdú, "Minimum probability of error for asynchronous multiple-access channel," *IEEE Trans. on Info. Theory*, vol. 32, no. 5, pp. 642-651, September 1986.
164. S. Verdú, "Adaptive multiuser detection," *Proceedings of the 1994 International Symposium on Spread Spectrum Technology and Applications*, pp. 43-50, July 1994.
165. R. Vijayan and H.V. Poor, "Nonlinear techniques for interference suppression in spread-spectrum systems," *IEEE Transactions on Communications*, vol. 38, no. 7, pp. 1060-5, July 1990.
166. A.J. Viterbi, "Very low rate convolutional codes for maximum theoretical performance of spread-spectrum multiple access channels," *IEEE Journal on Selected Areas of Communications*, vol. 8, no. 4, pp. 641-649, May 1990.
167. A.J. Viterbi, "The orthogonal-random waveform dichotomy for digital mobile personal communications," *IEEE Personal Comm.*, 1<sup>st</sup> Quarter, pp. 18-24, 1994.
168. J. Wang and L. Milstein, "Applications of suppression filters for CDMA overlay situations," *SUPERCOMM/ICC '92*, pp. 310.3, 1992.
169. J. Wang and L.B. Milstein, "CDMA overlay situations for microcellular mobile communications," *IEEE Transactions on Communications*, vol. 43, no. 2/3/4, pp. 603-614, February/March/April 1995.
170. P. Wei, J.R. Zeidler, and W.H. Ku, "Adaptive interference suppression for CDMA overlay systems," *IEEE Journal on Selected Areas in Communications*, vol. 12, no. 9, pp. 1510-1523, December 1994.
171. L.B. White, "Blind equalization of constant modulus signals using an adaptive observer approach," *IEEE Transactions on Communications*, vol. 44, no. 2, pp. 134-136, February 1996.
172. B. Widrow and M.E. Hoff, Jr., "Adaptive switching circuits," *IRE WESCON Conv. Rec.* pt. 4, pp. 96-104, 1960.
173. Yoshida, A. Uhirokawa, S. Yanagi, and Y. Furuya, "DS/CDMA adaptive interference canceller on differential detection in fast fading channel," *VTC 1994*, pp. 780-784, 1994.
174. H. Yoshino, K. Fukawa, H. Suzuki, "Interference canceling equalizer (ICE) for mobile radio communications," *ICC '94*, pp. 1427-1432, 1994.
175. Zengjun Xiang and Guangguo Bi, "Fractionally spaced decision feedback multilayer perceptron for adaptive MQAM digital mobile radio reception," *SUPERCOMM/ICC '92. Discovering a New World of Communications*, vol. 3, pp. 1262-6, 14-18 June 1992.
176. Zengjun Xiang and Guangguo Bi, "Complex neuron model with its applications to M-QAM data communications in the presence of co-channel interferences," *ICASSP-92: 1992 IEEE ICASSP*, vol. 2, pp. 305-8, 23-26 March 1992.
177. Zengjun Xiang and Guangguo Bi, "Polynomial perceptrons and their applications to fading channel equalization and co-channel interference suppression," *IEEE Transactions on Signal Processing*, vol. 42, no. 9, pp. 2470-2479, September 1994.
178. B. Zhu, N. Ansari, and Z. Siveski, "Convergence and stability analysis of a synchronous adaptive CDMA receiver," *IEEE Trans. on Comm.*, vol. 43, no. 12, pp. 3073-79, December 1995.
179. Z. Zvonar and D. Brady, "Adaptive multiuser receivers with diversity reception for nonselective Rayleigh fading asynchronous CDMA channels," *MILCOM '94*, vol. 3, pp. 982-986, 1994.