



PROJECT MUSE®

---

## The Expanse of Archaeological Remains at Nalanda: A Study Using Remote Sensing and GIS

M. B. Rajani

Archives of Asian Art, Volume 66, Number 1, 2016, pp. 1-23 (Article)

Published by University of Hawai'i Press

DOI: [10.1353/aaa.2016.0010](https://doi.org/10.1353/aaa.2016.0010)



➔ For additional information about this article

<https://muse.jhu.edu/article/619502>

# The Expanse of Archaeological Remains at Nalanda: A Study Using Remote Sensing and GIS

M. B. RAJANI

*National Institute of Advanced Studies (NIAS), Bangalore, India*

## *Abstract*

Historical records suggest that Nalanda was a Buddhist monastery of considerable repute with immense physical dimensions, which remained in existence from the fourth/fifth century until at least the end of the twelfth. This study investigates the area around Nalanda for evidence of human activity at such spatiotemporal scales using satellite images. Among its finds are: the site is much larger than the property protected by the Archaeological Survey of India; there is evidence of additional temples and monasteries; and there are indications of a large archaeological structure under Begumpur that was either a part of the Nalanda complex or a separate entity.

KEYWORDS: Nalanda, Mahavihara, Buddhist monastery, India, Xuanzang, remote sensing, GIS, DEM, Odantapuri

## Introduction

As a Buddhist center of learning, Nalanda had a reputation that extended beyond the Indian subcontinent.<sup>1</sup> It is unknown exactly when this center came into existence, and we do not have a continuous record for its activities. It must have gained a reputation for importance by the seventh century CE, attracting scholarly monks such as Xuanzang and Yijing from China.<sup>2</sup> By the twelfth century CE, however, there were other well-established Buddhist institutions in the region, such as Vikramasila (Bagalpur district, Bihar), Somapura (Paharpur, Bangladesh), and Odantapuri, competing for royal patronage. Their growing importance may have affected Nalanda's prominence in the region.<sup>3</sup> The Tibetan monk Dharmasvamin's account of his visit to Nalanda in 1234–36 CE does record some lingering activity in the monastery with a handful of monks, but he later reported witnessing the last of the monks abandoning Nalanda due to regional disturbances.<sup>4</sup> There is no record of what happened at Nalanda subsequently, and it is not conclusively known why Buddhist activities in the region ended sometime after the twelfth century.<sup>5</sup> Sparse historical documentation over the subsequent centuries resulted in Nalanda's erasure from living memory and local lore.

Were it not for the accounts of travelers (mainly Chinese) who visited Nalanda in its prime, its very existence might have remained unknown. Those accounts include not only descriptions of travel, stay, and the state of affairs of the region, but some of them also mention distances and directions of places relative to

other prominent and sacred landmarks in the vicinity.<sup>6</sup> The accounts of the Chinese travelers Faxian (337–422 CE) and Xuanzang (596–664 CE) were translated into English for the first time in the nineteenth century,<sup>7</sup> providing added impetus to the already growing interest in the discovery of Indian antiquity among British explorers.<sup>8</sup> Francis Buchanan was the earliest European investigator to visit the area. He indicated that he visited the ruins of Kundulpur near the village of Baragaon on January 8, 1812, and evocatively recorded the expanse of ruins and details of antiquities he observed.<sup>9</sup> Captain Markham Kittoe was an archaeologist who visited the site in 1847–48. Aided by the translation of Faxian's accounts,<sup>10</sup> Kittoe identified Baragaon as “Na Lo” of Faxian; later Alexander Cunningham identified these remains as the ruins of the famous Nalanda that Xuanzang visited.<sup>11</sup> Xuanzang, who resided at Nalanda between 635 CE and 641 CE, made by far the most detailed record of the spatial layout of various structures within the complex. He described structures such as monasteries, temples, images, stupas, a gate, walls, and tanks.<sup>12</sup> These descriptions heavily influenced nineteenth- and twentieth-century investigators in identifying structures revealed through archaeological explorations and excavations. However, the layout of structures excavated at the site does not match the layout described by Xuanzang.

This paper first reviews the historical context and the chronology of explorations and excavations to which the site was subjected, followed by a discussion of the scientific methods and technological tools used or otherwise referenced, together with associated terminology. It then studies water bodies in the immediate vicinity of

Nalanda to suggest a probable extent of archaeological remains at the site, and specifically identifies two large clusters of mounds (northern and southern) within these probable bounds. Details of specific features of interest on the southern and northern mounds are described, most of which lie outside the present boundary of the Archaeological Survey of India (ASI). The historical record is compared with observed facts to understand whether the two mounds were separate entities or part of one establishment. Finally, the new findings presented in this study are summarized, with suggestions for specific ways in which this research can be extended.

This paper uses labels assigned by ASI to refer to the temples and monasteries within ASI's boundary, plus it refers to nine features of interest that do not have ASI labels. While some of these features were hitherto unknown in the existing literature, a few appear to coincide with features in Cunningham's map (referenced frequently in this essay).<sup>13</sup> To avoid confusion, this paper uses labels F1 to F9 for these features of interest, and, where necessary, indicates the corresponding label from Cunningham's map along with justifications for asserting this correspondence.

## Nalanda: Historical Context and Chronology of Explorations and Excavations

### *Investigations by Cunningham and the Archaeological Survey of India (ASI)*

Alexander Cunningham first visited Nalanda in 1861 as Archaeological Surveyor for the Government of India. He undertook field surveys for four seasons between 1862 and 1865, making detailed observations and measurements.<sup>14</sup> Cunningham has been criticized for using unsystematic methods for identifying places,<sup>15</sup> lacking careful procedures for conducting explorations,<sup>16</sup> making crude and unscientific speculations,<sup>17</sup> and being obsessed with finding places mentioned in the accounts of Chinese pilgrims.<sup>18</sup> Despite these shortcomings, Singh notes that Cunningham's obsession yielded a number of major breakthroughs and correlations in the historical geography of ancient India. Furthermore, his "approach to historical geography involved contextualizing historical sites in relation to their physical landscape and ancient routes."<sup>19</sup> Cunningham maintained meticulous records of the spatial and topographical details of the sites he explored. Indeed, his documentation of archaeological sites—including mapping buildings, mounds, water bodies, and settlements almost to scale in relation to the surrounding topography—is unmatched for its time. Chakrabarti has remarked, "One cannot help feeling

that [Cunningham's] work did for Indian archaeology what the great Trigonometrical Survey achieved for the Indian landmass."<sup>20</sup> Cunningham's initial investigations were published in 1871,<sup>21</sup> along with a diagram entitled "Sketch of the ruins of Nalanda Mahavihara" showing the spatial distribution of villages, tanks, and such archaeological features as mounds, stupa, walls, statues, and monasteries.<sup>22</sup> The present work is also concerned with the topography and archaeological features in the environs of Nalanda and frequently refers to Cunningham's map of Nalanda.

ASI has conducted excavations in several phases, the earliest in 1863 and the most recent in 1983.<sup>23</sup> These excavations exposed a total of sixteen large structures (Fig. 1): a row of four temples or chaityas on the west (numbered 3, 12, 13, 14); a row of eight west-facing monasteries or viharas (1, 4, 6, 7, 8, 9, 10, 11) parallel to the temples; two smaller, north-facing monasteries (numbered 1A and 1B); an east-facing temple (2), situated behind monasteries 7 and 8; and, farther east, Sarai temple. Another monastery (12) existed north of monastery 11, but only the floor plan was discovered during excavations. Figure 2 depicts the timescale for the excavation at each of these large structures. The horizontal axis names each structure—the numbered temples and monasteries are prefixed with a "T" and "M," respectively (the only exception is Sarai), and the corresponding labels in Cunningham's sketch are also indicated.<sup>24</sup> The vertical axis indicates the (sometimes fragmented) period over which each structure was excavated.

The excavation of the site began in 1863 with the mound containing ruins of what later was called temple 12 ("F" in Cunningham's sketch). This first location was selected by Cunningham on the strength of measurements and observations that convinced him the mound with "a great hollow in the centre" contained ruins of a temple.<sup>25</sup> Buchanan, too, had earlier singled out this mound from several "heaps" and "conical heaps," noting that it "has been opened for materials, and seems to have contained only a very small square cavity."<sup>26</sup> Buchanan's accompanying sketch described this mound as "heap opened,"<sup>27</sup> which might have influenced Cunningham's initial choice. The actual excavation of temple 12 was conducted by Captain Marshall,<sup>28</sup> and was followed in 1871 by the excavation of temple 2.<sup>29</sup> Nalanda became a protected site under the Indian Monument Act VII of 1904, and explorations and excavations resumed in 1915 after a four-decade hiatus.<sup>30</sup> The period from 1915 to 1938 witnessed excavations that uncovered the largest spatial expanse of Nalanda's hidden treasures: temple 3, monasteries 1, 4, 1A, 1B,

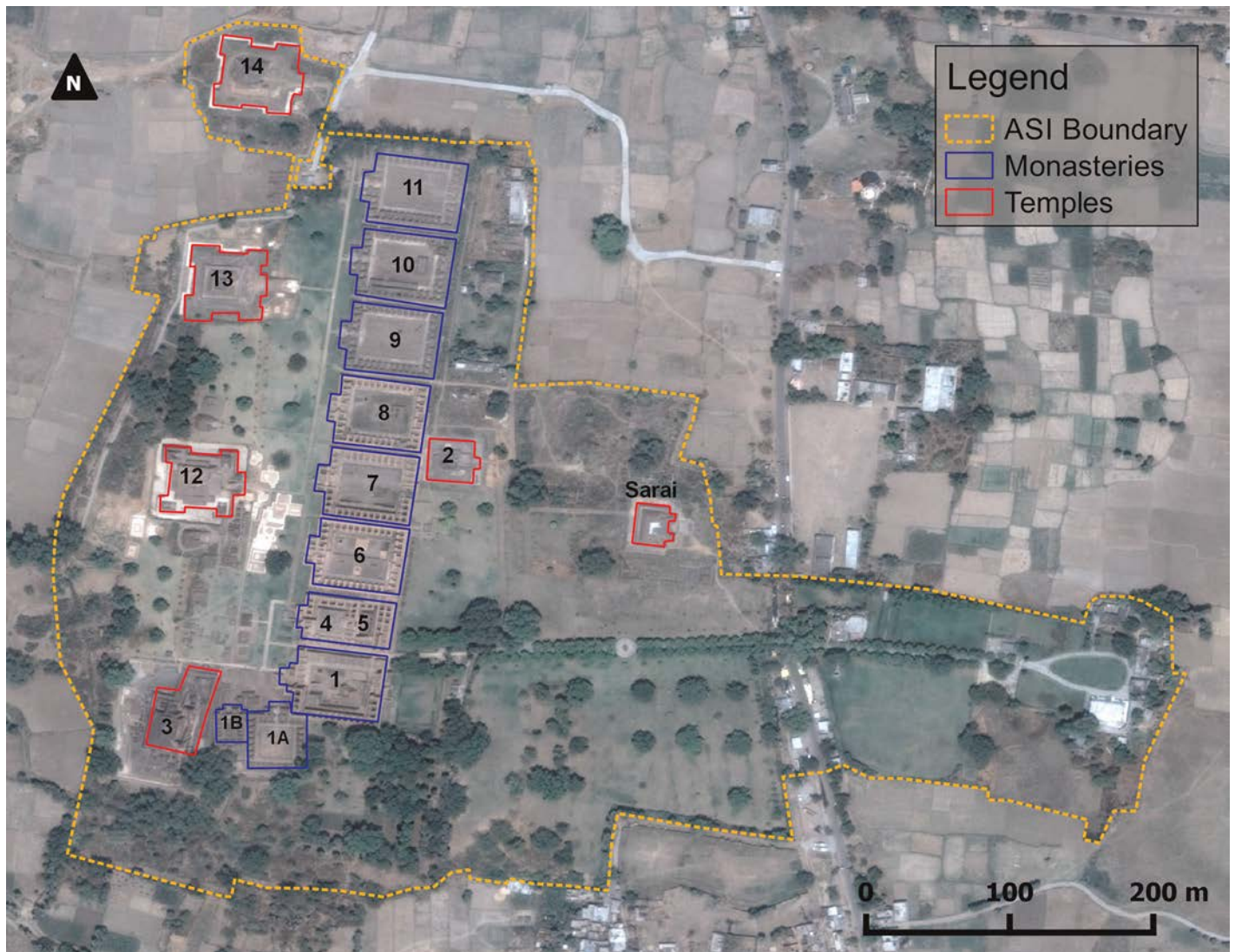

FIG. 1. Image of Nalanda (Google Earth Pro image dated May 8, 2010) showing the large structures within the ASI property boundary.

5–12, and temple 13.<sup>31</sup> Subsequently there were long pauses in activity, and only two additional structures, temple 14 and Sarai temple, were excavated before large-scale excavations ceased, in 1983.<sup>32</sup> The spatial arrangement of structures at Nalanda (see Fig. 1) indicates that the sequence of locations chosen for excavation spread from one mound to the neighboring one, starting from the first location chosen by Cunningham.

#### *The Extent of the Nalanda Site*

In 1812 Buchanan approached Nalanda from the north and observed that the ruins commenced near Dighi Pokhar (the tank east of the village Begumpur).<sup>33</sup> Even in 1907 there were visible ruins at Begumpur: “Bargaon

[Baragaon] and the neighbouring village of Begumpur to the west of Dighi Pokhar contain masses of ruins which have never been properly explored, and there seems little doubt that a detailed and systematic exploration of the whole area would be rich in valuable results.”<sup>34</sup> It is curious that Cunningham’s 1871 sketch did not record any ruins in Begumpur other than the fort built by the eighteenth-century military adventurer Kamgar Khan,<sup>35</sup> but it did identify several other mounds that lie to the south and west of the current ASI boundary, so there was awareness in the nineteenth century that archaeological remains were spread over a large area. The excavation and subsequent conservation and preservation, however, are limited to land that ASI has been able to acquire.<sup>36</sup> Given the painstaking nature

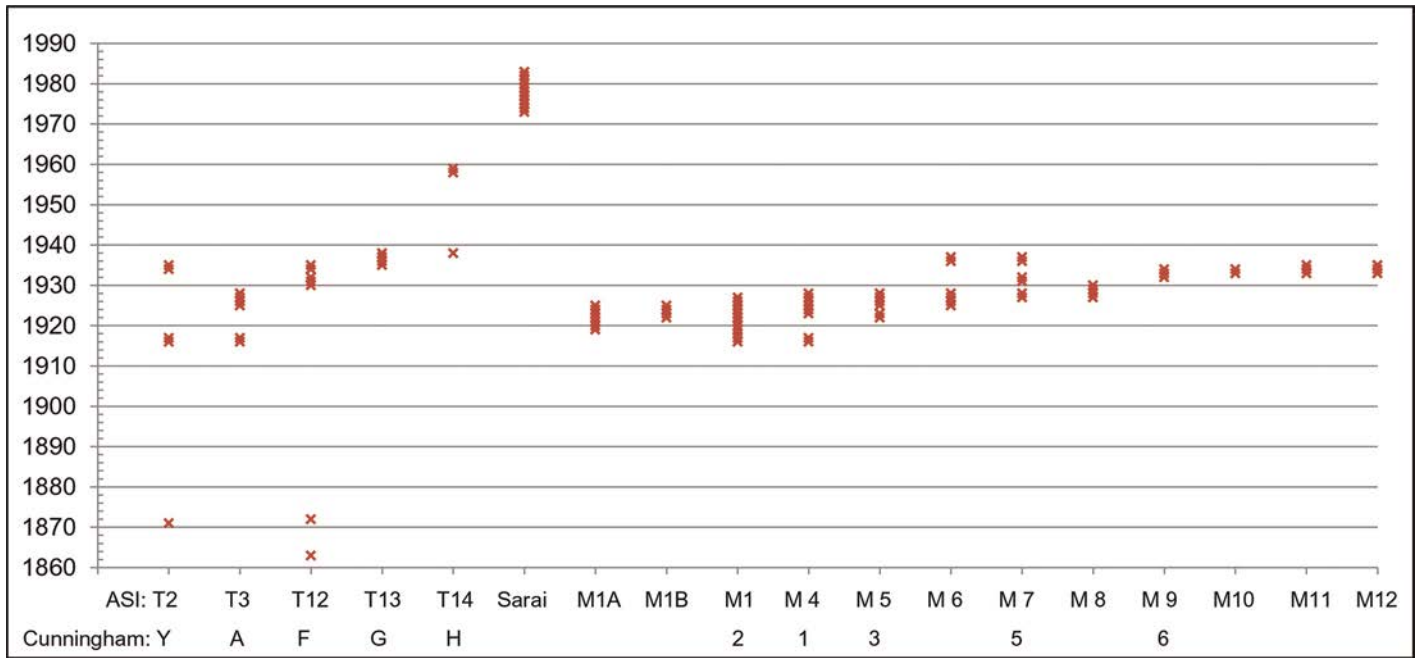

FIG. 2. This graph depicts the excavation time line for each of the large structures at Nalanda. The vertical axis indicates the period during which structures were excavated. The horizontal axis names each structure using the ASI nomenclature and Cunningham's corresponding label (wherever available).

of conventional archaeology, coupled with significant sociopolitical and economic shifts in the region over the past 150 years, it is perhaps unsurprising that only a small portion of the area with archaeological potential has been uncovered. The unprotected area outside the ASI boundary has been exposed to the growing demands of human habitation and agriculture, and the potential of Begumpur appears to have been forgotten.

In addition to physical remains, historical eyewitness accounts also suggest that Nalanda's spread was greater than our present understanding. If Nalanda had sustained anywhere near the 10,000 residents mentioned by Xuanzang<sup>37</sup> (or even the 3,000 residents recorded by Yijing, another Chinese traveler, who stayed at Nalanda between 671 CE and 693 CE<sup>38</sup>) solely within the currently excavated extent, the monasteries would have had to have been multistoried—premodern skyscrapers—which is unlikely.<sup>39</sup> Granting the possibility that the number of residents is somewhat exaggerated, it is nevertheless clear that even the seventh-century extent of the complex must have been substantially larger than the currently excavated area, not to mention any additions that could have been made during the nearly five centuries that Nalanda remained functional after these Chinese travelers visited. The inability to corroborate the excavated remains with facts mentioned in accounts, and the vast quantity and spread of antiquity in the region, has led investigators to believe that the site was

much larger than the currently exposed archaeological remains.<sup>40</sup> In light of this, the present study examines the site of Nalanda and its surroundings using remote sensing technology to identify features of archaeological interest in the vicinity that might be connected to the site.

### Scientific Methods and Technological Tools

Remote sensing is the science of acquiring information about an object without coming into physical contact with it. It is thus a purely noninvasive technique that leaves the object undamaged for posterity. This study is concerned with space-based remote sensing, whereby orbiting satellites take images of the earth's surface. These images allow a site to be studied synoptically, in context with adjacent regions, and enables one to delineate connections and alignments between various surface features. High-resolution images (~1m per pixel) show finer details, like buildings and roads, whereas coarser resolutions (5.8m, 23.5m, or 30m per pixel) show features that are part of the larger landscape, such as drainage patterns and old water bodies, which, somewhat counterintuitively, can be difficult to perceive at higher resolutions. A variety of satellite sensors is available, each attuned to different parts of the electromagnetic spectrum. This study has mainly explored images corresponding to the visible and infrared bands.

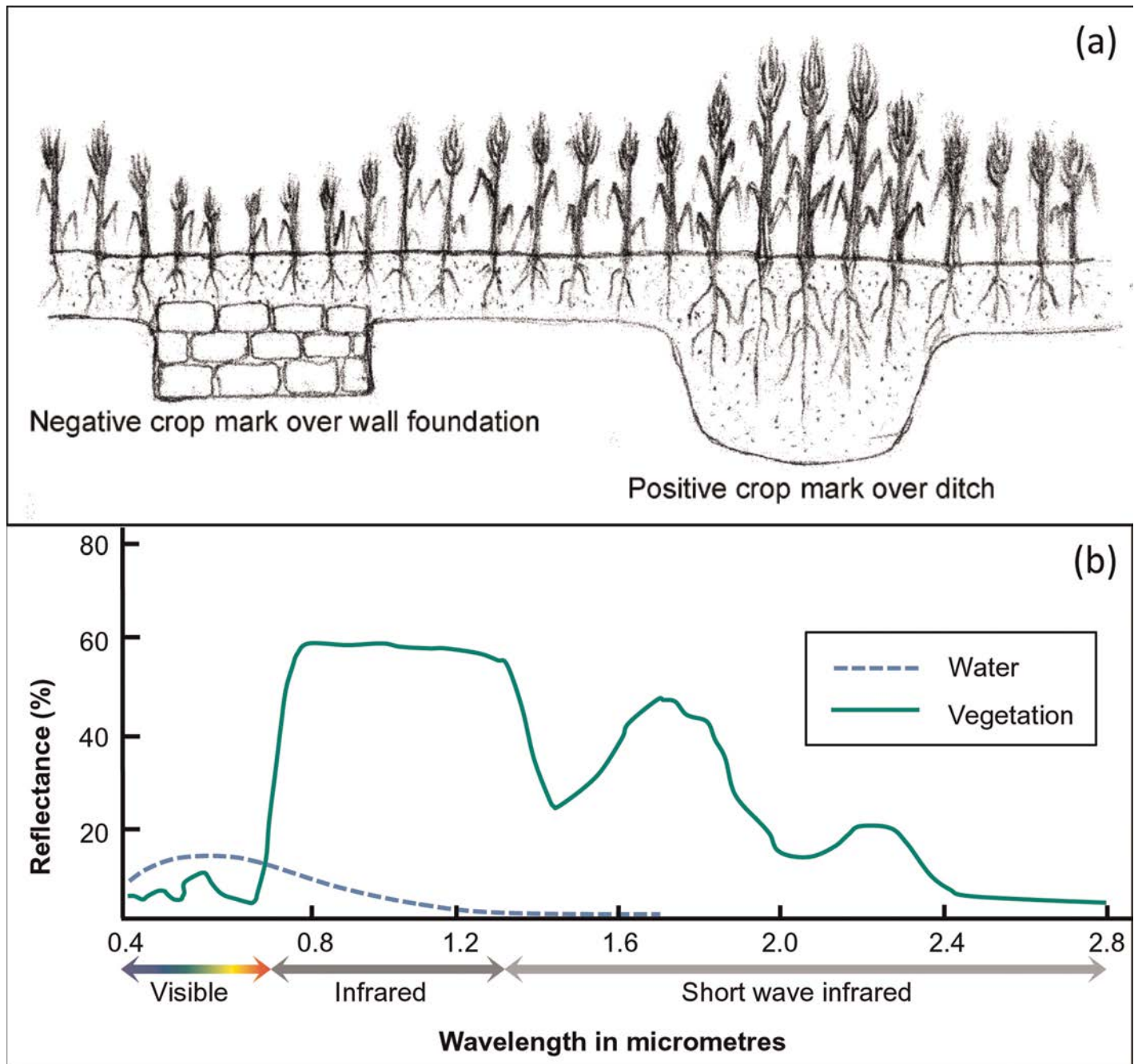

FIG. 3. (a) The effect of buried archaeological features on the growth of crops: negative crop marks over wall foundations and positive crop marks over ditches. (b) Spectral curve showing the percentage of reflectance for vegetation in several spectral bands, with infrared reflectance being markedly higher than others.

### *Infrared Imagery*

Buried archaeological remains often affect the health of surface vegetation and create positive or negative crop marks that reveal themselves as large patterns when viewed synoptically (Fig. 3a).<sup>41</sup> Archaeological features such as disused moats, canals, tanks, and pits collect silt over the years, obscuring their surface forms. If and

when this area is covered by vegetation, the growth is more luxuriant (positive crop marks) compared with adjoining regions: the vegetation benefits from extra moisture and nutrients held by the loose deposition of silt in the subsurface cavity. In contrast, when archaeological structures such as brick or stone walls and foundations, streets, and solid floors are buried beneath soil and vegetation after the original edifices have collapsed,

the surface is often cleared of debris for either reuse of material for new construction or leveling the land for agriculture. Since the tightly packed subsurface obstructs plant roots, conditions are unfavorable for growth (shown as negative crop marks). Such subtle variations in growth are nearly invisible on the ground, and also are often unseen in visible-wavelength aerial/satellite imagery. Using infrared images, however, one can readily discern vegetation growth patterns over the ground following the lines of the buried features, revealing their plan and layout,<sup>42</sup> because vegetation reflects significantly more sunlight in the infrared band than in the visible band (Fig. 3b). Although one is able to see more variation in the shades of vegetation in infrared imagery, patterns indicating subsurface archaeological remains may be visible only under certain weather/moisture conditions. Therefore, vegetation cover should be analyzed across seasons in order to isolate all potential archaeological features, which should then be analyzed in the context of the layout of known archaeological remains.

### *Digital Elevation Model*

A Digital Elevation Model (DEM) is an image that captures three-dimensional topographical details and shows variations in height as a sequential band of colors. When a DEM is visualized on a computer screen, the height associated with each pixel can be examined using Geographic Information System (GIS) software. GIS also enables analysts to overlay images with spatial information from other sources. In this paper, for example, village and ASI boundaries, tanks, temples, and monasteries traced from the Google Earth image illustrated in Figures 1 and 4 have been overlaid on a DEM (see Fig. 6). Although many technologies can generate a DEM, the present study used two specific types: (1) Space Stereoscopy, whereby two images of the same location are taken by a satellite (CARTOSAT1, in this case) from two different positions in space; and (2) Interferometric SAR, whereby two images from a RADAR sensor are used (here, the Shuttle Radar Terrain Mission [SRTM]).

### *Other Tools*

The field studies described in this work were conducted with the aid of a handheld Global Positioning System (GPS) device, which receives satellite signals to determine its exact geographical location at any given point in time. A GPS is useful in this context in two ways:

(1) to guide a researcher to specific features observed on remote sensing images or maps; and (2) to record the latitude and longitude of any additional points of interest observed during field studies, for subsequent analysis in the context of other data in the researcher's GIS database.

Ground Penetration Radar (GPR) is a noninvasive sensor used on the ground surface. It emits radar pulses to produce images of subsurface composition based on return signals. While this study has not used GPR, it advocates the potential of applying this technology at specific sites within and around Nalanda.

## **A Synoptic View of Nalanda**

Any long-lasting residential establishment must draw resources from the local environment for its sustenance, water being one of the most important. A community may settle close to a water source, or conserve rainwater by constructing tanks, dams, and embankments, or draw water by diverting it from nearby drainage. For instance, a number of dams, embankments, and large reservoirs were found during a survey of the Sanchi area in central India.<sup>43</sup> Archaeological evidence suggests that these structures were contemporary with the Buddhist monastic sites nearby.<sup>44</sup> Archaeological surveys have also identified large reservoirs adjacent to monasteries at the Buddhist site of Thotlakonda in Andhra Pradesh,<sup>45</sup> and a survey of the area around Anuradhapura in Sri Lanka has recorded hundreds of reservoirs that were constructed to support agriculture and sustain villages.<sup>46</sup> These man-made alterations to the geomorphological setting often leave tell-tale scars on the earth's surface, which can sometimes be recognized when the overall region is observed using satellite imagery. Satellite-based synoptic observation has revealed several landscape features near Sanchi,<sup>47</sup> palaeochannels near Harappan sites in north-west India,<sup>48</sup> and similar features at a medieval site in southern Karnataka.<sup>49</sup>

### *A Cluster of Water Bodies*

For the purpose of observing larger landscape features around Nalanda, Landsat images of the region at 30m resolution have been used. Landsat Viewer is an online interface for viewing Landsat images in natural color.<sup>50</sup> When zoomed in to Nalanda (25°08'13.60"N and 85°26'36.47"E) one can find a total of 92 images, taken in different seasons across a period of nearly fifteen years (October 12, 1999, to February 6, 2014).<sup>51</sup> A careful examination of these shows a series of water

bodies surrounding Nalanda. South Bihar has several scattered water bodies, but the ones clustered around Nalanda form a pattern not seen elsewhere in the vicinity. This suggests that the water bodies are associated with the site, and their pattern may help trace its extent.

Figure 4 shows the water bodies surrounding the excavated site. It also shows boundaries of neighboring villages, and marks the probable extent of the archaeological remains at Nalanda. This extent should be considered approximate rather than the actual boundary, however. Definite boundaries of a site, such as walls (fortification) or a moat, manifest themselves on satellite images as an encircling crop mark,<sup>52</sup> but such a continuous encircling feature is not detectable around Nalanda. Low-lying areas of desiccated moats can sometimes form isolated tanks, but the continuance between them is often revealed in the shape and pattern of agricultural fields or land cover.<sup>53</sup> Image analysis on Nalanda to date has detected only isolated tanks (some of which have now been converted into agricultural fields), with no indication of connections between them. Therefore, the cluster of tanks seems to indicate the spatial spread of the establishment rather than a definite boundary. Tanks in the vicinity of the site were noticed and explicitly mentioned by Chinese travelers and British explorers. In *Nalanda*, published in 1998, Bhaskaranatha Misra listed the names of about twenty-nine tanks and reported that local tradition speaks of fifty-two tanks.<sup>54</sup> Much earlier, in 1963, D. R. Patil suggested that these tanks were not created to serve as reservoirs, but were dug simply to get the earth necessary to make the enormous quantity of bricks required for building the monasteries, temples, and other structures.<sup>55</sup> In 2009 D. Anand mapped these tanks and calculated the number of bricks that might have been produced from the total volume of earth removed.<sup>56</sup>

The present study has made two observations that suggest brick making might not have been the only purpose for which the tanks around Nalanda were excavated. First, one can extend to several tanks identified in Figure 4 the observation made by J. Kamini et al. in 2007 regarding the geometry in the layout of four tanks along the periphery of the ASI property.<sup>57</sup> The shapes, location, and layout of many of these tanks show careful planning: they are mostly geometrical (squares or rectangles), with sides roughly parallel to the four cardinal directions. Such precision would have been unnecessary if these tanks were excavated solely for purpose of mining earth for brick making. Second, there are indications to suggest that the largest tank, Dighi Pokhar, was river-fed.

### *A Palaeochannel*

The eastward spread in the layout of Dighi Pokhar is in sharp contrast to the other large tanks (Indra Pokhar and Pansokar Pokhar) that snugly bound the area containing the excavated remains (see Fig. 4). Analysis of the CARTOSAT1 image reveals a palaeochannel from the nearby river Panchana to almost the eastern end of Dighi Pokhar (Fig. 5).<sup>58</sup> The water in this palaeochannel would have curved off from Panchana at the location 25°04'50"N and 85°30'49"E (where the average height is sixty-five meters) and flowed northwest for about ten kilometers to the east end of Dighi Pokhar (where the average height is fifty-eight meters). It is also possible that excess water from Dighi Pokhar spilled over to other tanks. The Nalanda region therefore received water through this palaeochannel from the river Panchana at some time in the past, but a ground exploration by archaeologists and geologists is necessary to determine whether this flow was contemporaneous with activity at Nalanda. Similarly, ground explorations similar to those conducted at Sanchi<sup>59</sup> are necessary to obtain hydrological indications to confirm whether the diversion from river Panchana was man-made or natural. (The channel itself is not perfectly straight—the slightly meandering shape seen in Figure 5 could be natural—but even man-made canals sometimes assume shapes dictated by topographical contours.)

### *Two Mounds*

The terrain containing water bodies will obviously be low-lying, whereas one expects the area flanked by these tanks to be elevated. The topography within this area, however, might have finer shapes, indicating concealed archaeological remains. In order to explore this possibility, the present study initially analyzed the DEM of 90m resolution from Shuttle Radar Terrain Mission (SRTM), which is freely available online.<sup>60</sup> This image indicated that the area within the proposed extent comprised two distinct mounds. At such coarse resolutions it was impossible to discern finer details, such as shapes of mounds, so a much higher resolution DEM was analyzed. Figure 6 shows a DEM of 5m pixel resolution (generated using stereo pair images from CARTOSAT1) that reveals two distinct large mounds and the shape of their boundaries.<sup>61</sup> The southern mound is larger and comprises the whole of the excavated area and adjacent regions, including the villages of Muzaffarpur, Kapatia, Surajpur, and Baragaon. The northern mound is smaller, covering Begumpur and its environs. The two mounds are



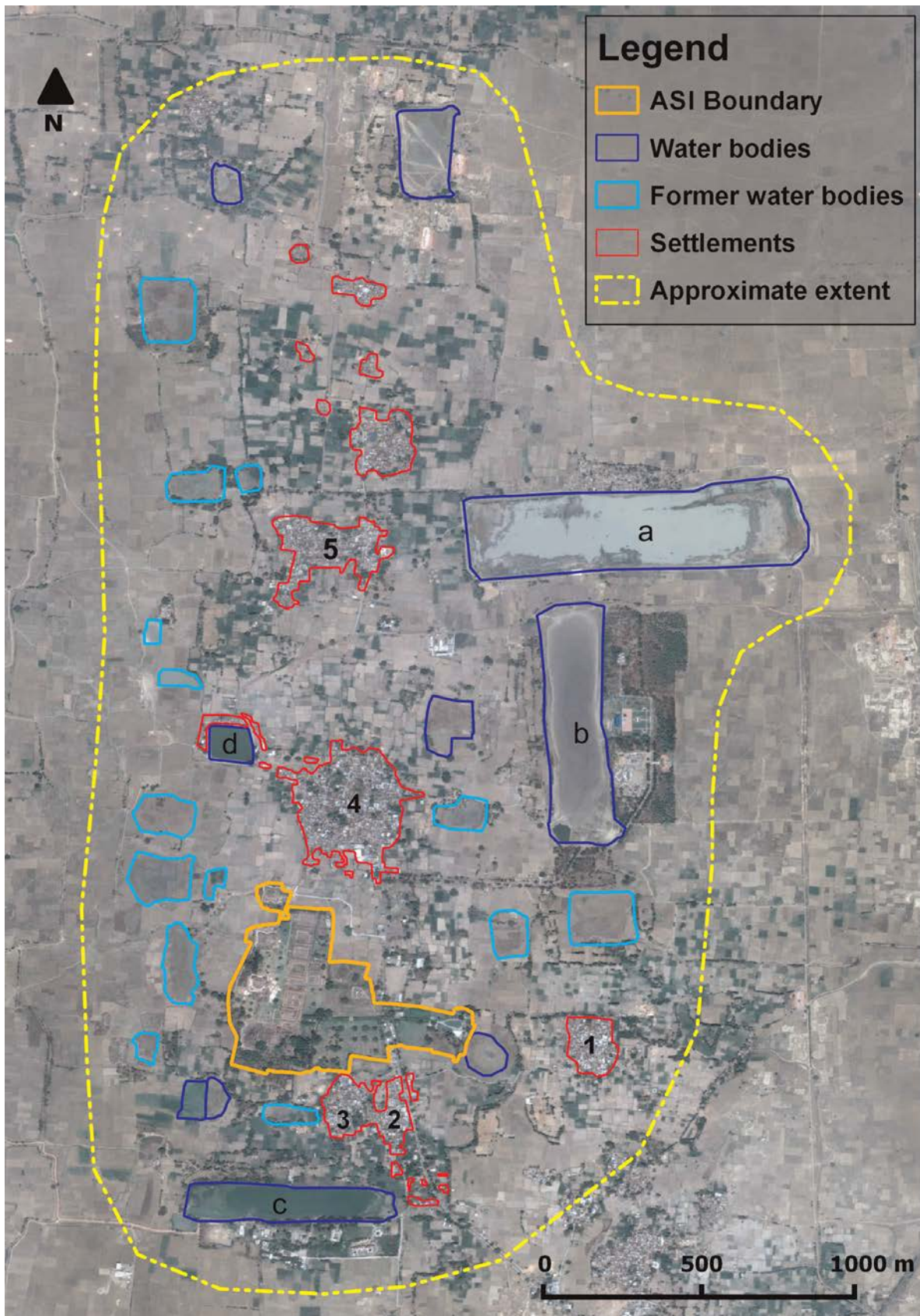

FIG. 4. Water bodies/tanks (Pokhar): (a) Dighi, (b) Pansokar, (c) Indra, (d) Suraj. Settlements: (1) Sari Chak, (2) Kapatia, (3) Muzaffarpur, (4) Baragaon and Surajpur, (5) Begumpur. Map Data: Google, DigitalGlobe.

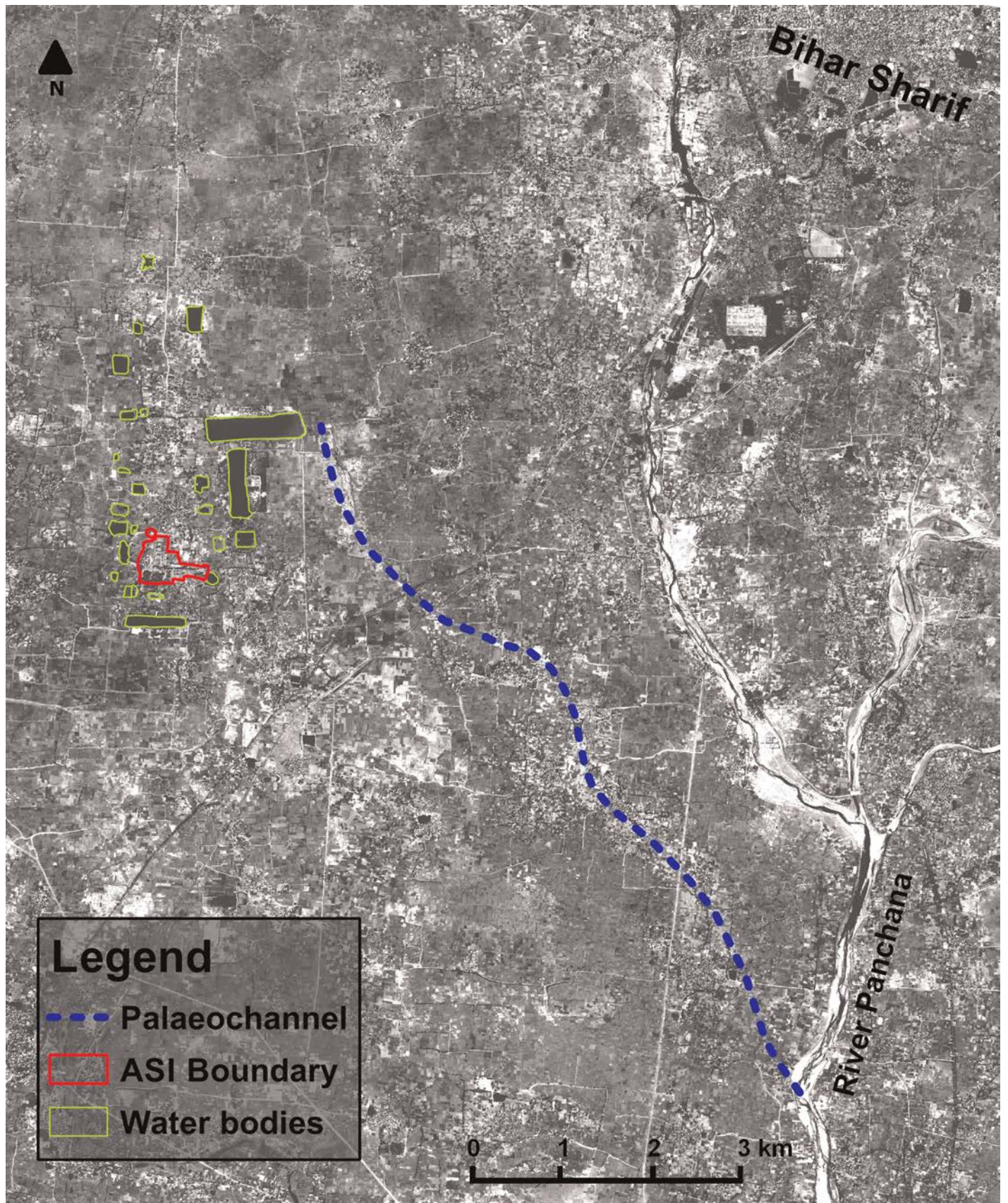

FIG. 5. A regional view of Nalanda and environs as observed by CARTOSAT-1 Aft image showing the river Panchana and the palaeochannel. *Note:* This image has slight differences from that in the print version of this article.

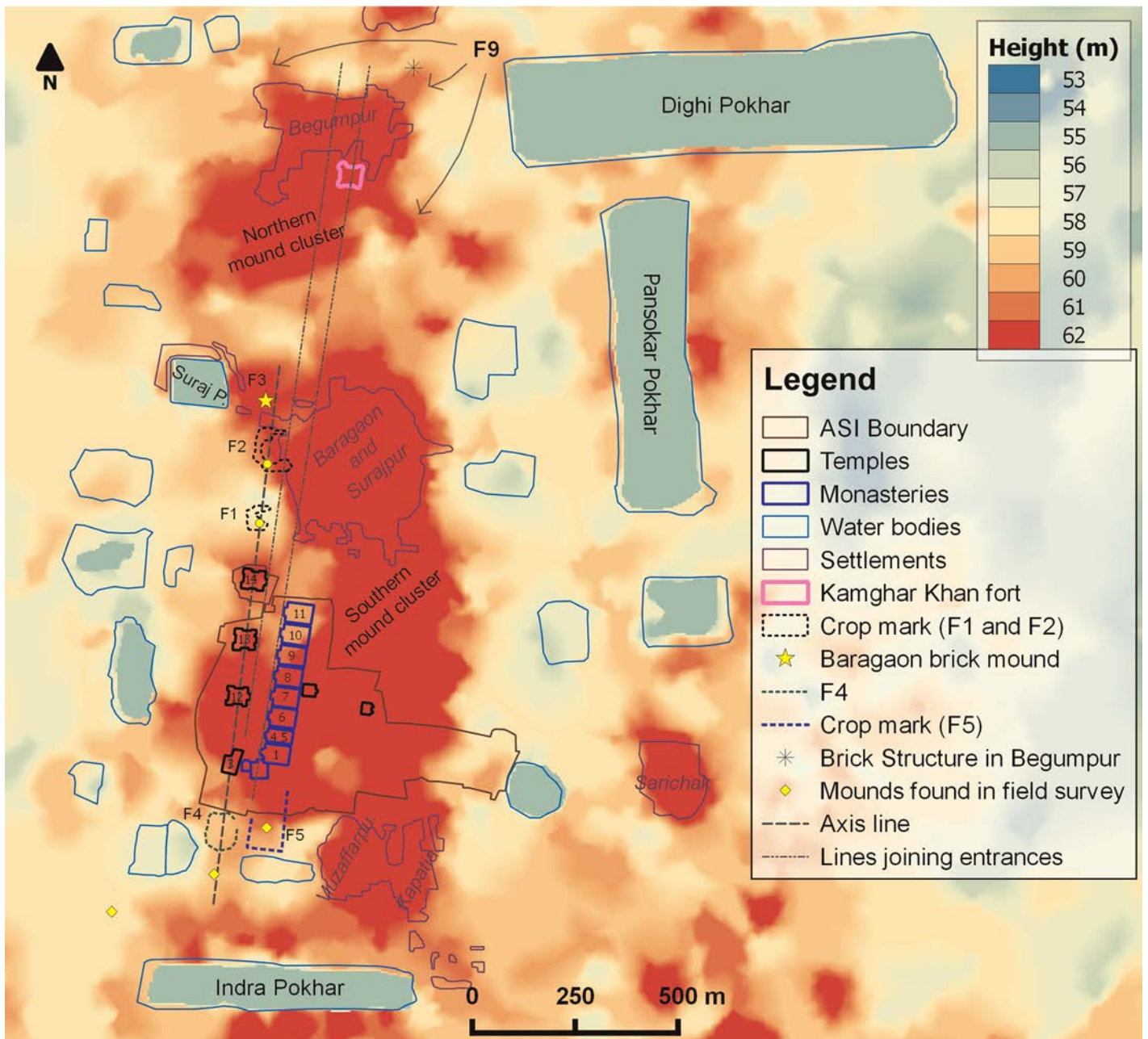

FIG. 6. DEM (5m resolution) showing shapes of mounds in the context of the excavated area, villages, and water bodies/tanks.

separated by a gap of about 500 meters, whose significance will be explored after carefully detailing the extent and spatial context of the archaeological remains in each mound.

### The Southern Mound

First, let us consider the known large structures of the site—the temples (2, 3, 12, 13, 14, and Sarai) and the monasteries (1A, 1B, 1, 4–11). These structures, which

have been excavated and are protected by the ASI, lie within a boundary wall. ASI's property is wholly confined to the southern mound and covers only about one-third of the mound's approximately 180-acre extent. The southern mound is elongated, stretching 1.6 kilometers in a north-south direction. The northern end is as wide as the settlement of Baragaon and Surajpur combined, about 400 meters; the widest band, where temples 2, 3, 12, and Sarai are located, measures about 620 meters across; and the southern end tapers to 300

meters across, covering Kapatia and Muzaffarpur. The Baragaon/Surajpur settlement to the north is connected with the Kapatia/Muzaffarpur settlement to the south by a long, continuous, high mound that lies east of the excavated area.

The present study further explores this region by analyzing multispectral and high-resolution satellite images to identify surface vegetation patterns. Three different multispectral images with seasonal variations were analyzed: a dry season (May 29, 2008); a wet season (November 29, 2005); and a season in between (February 12, 2009).<sup>62</sup>

### *Evidence for Two Temples*

The layout of Nalanda's large structures has a systematic pattern. Patil noted that the buildings "show clearly a sort of preconceived planning and thought..."<sup>63</sup> This is more noticeable in the way monasteries 1, 4, and 6–11 stand in a neat row closely abutting each other. The temples also lie along a straight line, which again indicates careful planning.

Analysis of the multispectral images detailed above has revealed two successive "crop mark" patches, north of temple 14, labeled F1 and F2 (Fig. 7a). When a line through the centers of temples 12, 13, and 14 is extended northward, F1 and F2 lie along this axis. Furthermore, a brick mound in Baragaon (labeled F3 in Figure 7a; coordinates: 25 08'37.69"N 85 26'34.21"E) also lies within a few meters of this axis-line. Its presence has been recorded by Buchanan (1812), Cunningham (1861), and Broadley (1873).<sup>64</sup> In 1998 Misra observed that the mound "appears to have been a chaitya in the row of the excavated Chaityas 3, 12, 13 and 14 of the Nalanda site,"<sup>65</sup> which is corroborated by our observation above.

In addition to their linear layout, there is also regularity in the intervals between temples: temples 12 and 13 are 153 meters apart (measured from center to center), and temples 13 and 14 are similarly 158 meters apart. The distance along the axis-line between temple 14 and mound F3 is about 476 meters, which is almost exactly three times the successive gap between temples noted above. If we place dots at 158-meter intervals along the axis-line between temple 14 and mound F3, they fall within patches F1 and F2 (see Fig. 7a). Taken together, these observations suggest that F1 and F2 were locations of past temples. Note that F1 and F2 are positive crop marks; as mentioned earlier, such marks are created by buried structures where earth was removed (such as pits, ditches, moats, and canals). Therefore, if

structures had indeed existed at F1 and F2, they subsequently were heavily quarried for bricks. The ruins had been a free source of bricks for centuries,<sup>66</sup> until passage of the Ancient Monuments Preservation Act in 1904 made such acts punishable by law.<sup>67</sup> As F1 and F2 are closest to the largest settlements in the region (the villages of Baragaon and Surajpur), it is conceivable that, over the centuries, bricks from these structures were recycled for constructing buildings and paving roads. Mound F3 would have been equally susceptible to heavy brick mining. Indeed, in connection with mound F3 (marked "N" on his map), Cunningham notes: "From its close proximity to the village, this ruin has supplied materials for all the existing houses, and is consequently of much smaller dimensions..."<sup>68</sup> On the basis of his excavations, Cunningham determined: "If the relative proportion of base to height was the same as that of the Buddha-Gaya Temple, the height of this temple could not have been less than 228 or 240 feet, according to which side of the base is taken for calculation."<sup>69</sup> Mound F3 currently is used as a multitiered terrace for drying hay and grains and grazing cattle (Fig. 7b).<sup>70</sup> The temple structure on the summit is modern, housing a Pala period stone sculpture of Mahishasuramardini worshipped by locals.<sup>71</sup> The ground on which temples F1 and F2 might have once stood is now used for agriculture, and no ruins are discernible on the surface.

### *Evidence for Additional Structures*

To the south of the main row of temples 3 and 12–14 and monasteries 1, 4, and 6–11 are two features marked as F4 and F5 (Fig. 8) that were identified on the previously mentioned CARTOSAT1 image. Feature F5 exhibits three sides of a rectangle, the eastern and western edges of which align respectively with the eastern and western walls of monasteries 1, 4, and 6–11. The distance between the southern edge of feature F5 and the southern wall of monastery 1 is 230 meters. This suggests that the row of monasteries may have extended south of monastery 1, and if they were of similar size then F5 is large enough to accommodate three or four more. A ground study of the northeast corner of F5 (approached from within the ASI boundary wall) showed undulations, as though the surface cover was hiding some structure underneath. It would have been desirable to make detailed ground observations along the boundary of feature F5, but obstructions caused by wild vegetation and the ASI boundary wall prevented this. The ground study therefore accessed the remaining features from the south (via Kapatia and Muzaffarpur villages). At

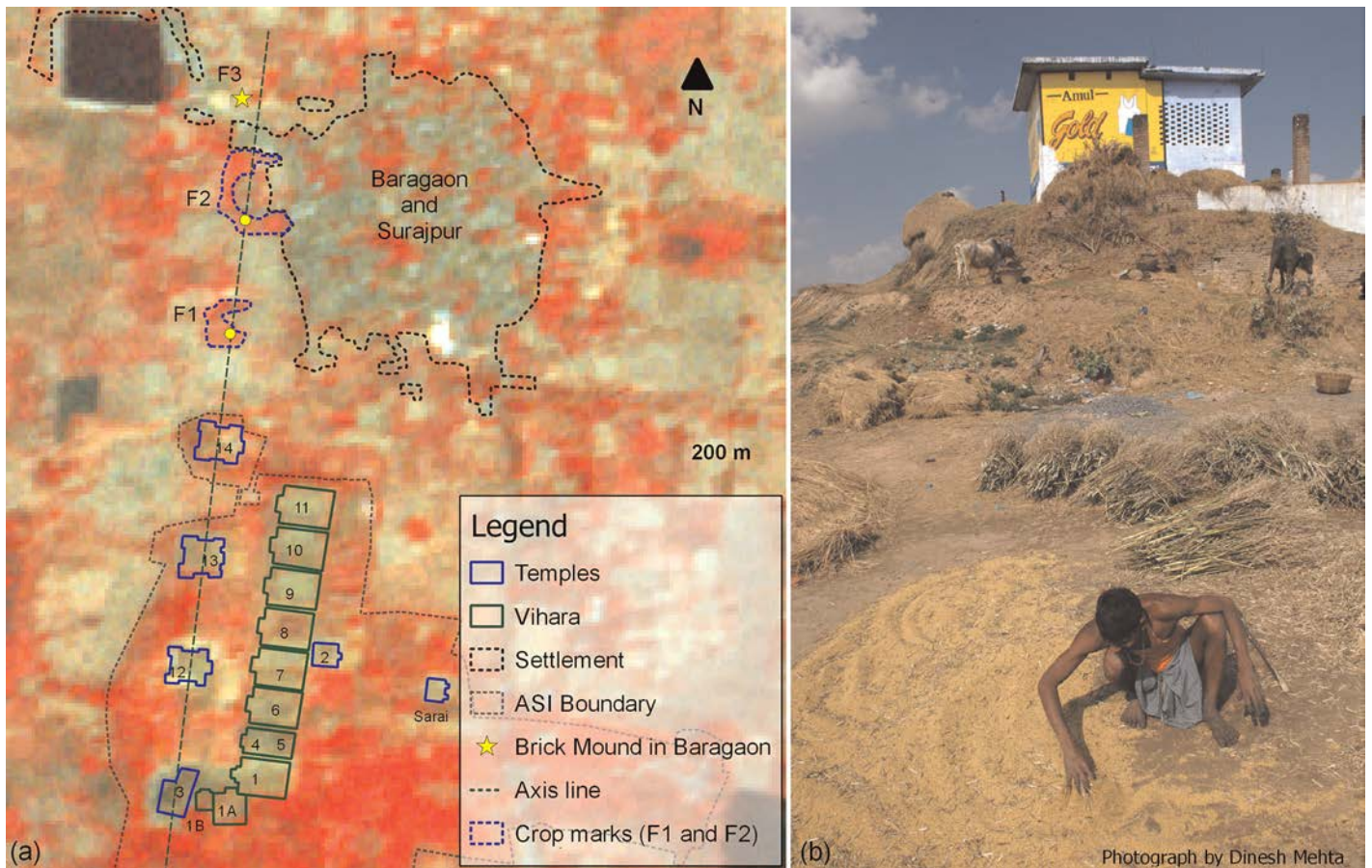

FIG. 7. (a) Multispectral image from IRSP6 LISS-IV showing crop marks north of the excavated site of Nalanda; (b) brick mound in Baragaon.

the center of feature F5 is a circular mound labeled F6 (see Fig. 8), which is about 3–4 meters high, with many trees growing over it.

The region around feature F4 is dotted with mature trees whose canopies obscure the fields below. However, there is a conspicuous gap in the tree canopy at the location of F4 itself (see Fig. 8). On the ground, this area is flat and is used for agriculture. It is possible that the subsurface of feature F4 has a tightly packed foundation that makes it difficult for large trees to take root. F4 lies on the axis-line, and the gap between temple 3 and F4 is comparable to the intervals observed between other temples farther north on this line. These observations suggest that F4 might also be the location of a buried temple.

During the field survey, another circular mound (labeled F7 in Fig. 8) was found to the south of feature F4 along the axis-line. Cunningham's diagram marks a row of mounds (H, G, F, E, A, B, C, and D) running north to south. Of these, H, G, F, and A are identified with temples 14, 13, 12, and 3, respectively.<sup>72</sup> Cunnin-

ham situated C and D between Rahela Pokhar to the west and Kargidya Pokhar to the east. An identical spatial relationship is observed for features F4 and F7, which suggests that they correspond to Cunningham's mounds C and D, respectively.<sup>73</sup> A third mound, about 4–5 meters high, was found 300 meters southwest of feature F4 (labeled F8).<sup>74</sup>

### The Northern Mound

The northern mound is much smaller than the southern one. It covers an area of approximately 75 acres, and contains a very interesting topographical relief feature (labeled F9; see Figs. 6 and 10c). The F9 feature covers most of the middle and northern portion, and constitutes approximately two-thirds of the total area of the mound. The protruding ends on the northwest, northeast, and southeast extremes of F9 form three corners of a shape consistent with the buried foundations of a four-pointed structure. The eastern extreme of F9 is 220 meters west of Dighi Pokhar, and the ruins of this

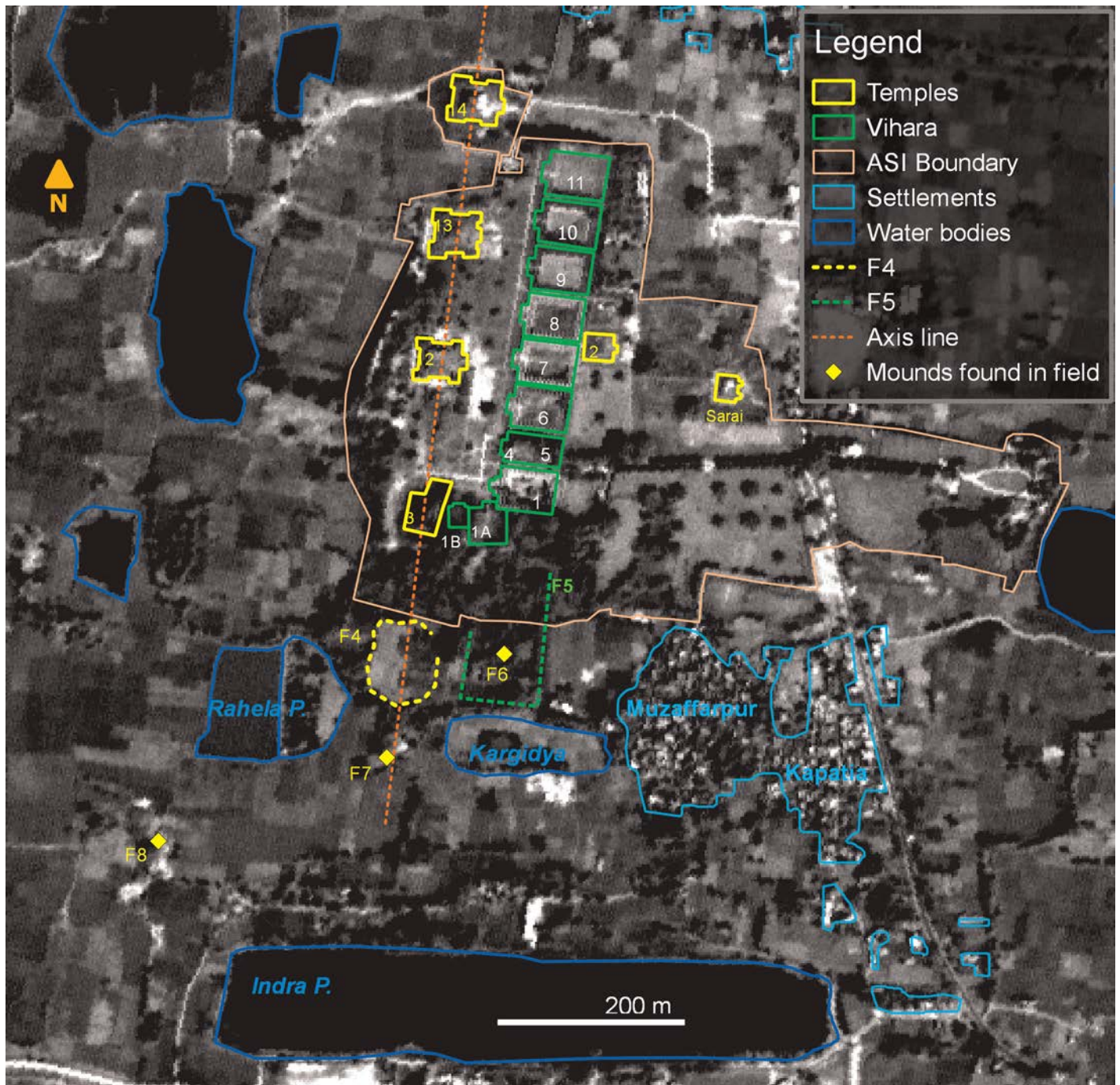

FIG. 8. CARTOSAT-1 image showing crop marks south of the excavated site of Nalanda, and the locations of mounds found during the field survey. *Note:* This image has slight differences from that in the print version of this article.

structure were still visible when Buchanan visited in 1812. He approached Nalanda from the northeast after visiting Bihar Sharif. In his journal, Buchanan noted that he crossed river Panchana and “About four miles from thence I came to a tank called merely Dighi, which is the commencement of the ruins. . . . Immediately west from this tank is a very considerable space elevated with the fragments of brick.”<sup>75</sup> The “considerable

space” he refers to, lying west of Dighi Pokhar, would be the vast area of F9. This ruin “elevated with the fragments of brick” would have been still visible at the time. By way of further confirmation, he states: “Its north end is occupied by part of the village Begumpur, and a small ruinous mud fort erected by Kamgar Khan.”<sup>76</sup> Begumpur has grown since Buchanan saw it and has spread to occupy the whole of the northern part of

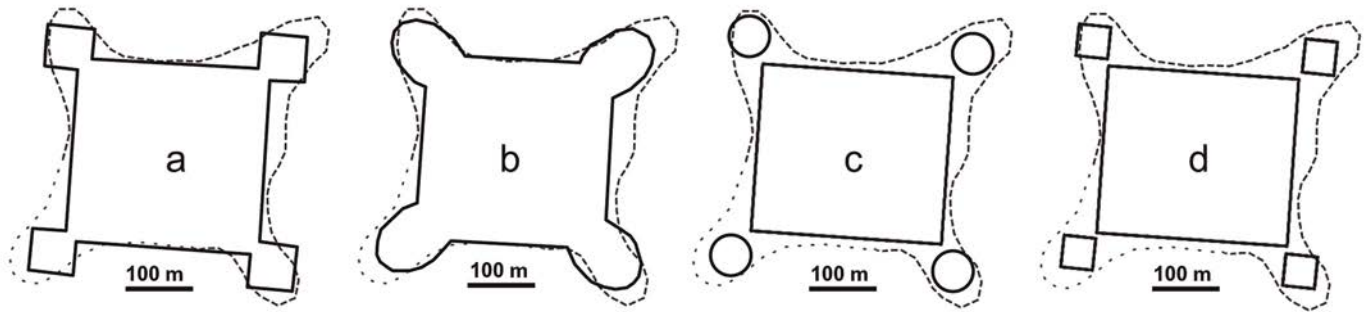

FIG. 9. The dotted line is the outline of feature F9; a, b, c, and d are four possible shapes (of the hypothesized buried structure) that are compatible with this outline.

F9 (see Fig. 6). The Kamgar Khan mound (containing remains of the fort) now lies immediately south of the village, and is clearly visible on Google Earth and GeoEye images. It is marked in the plan made by Cunningham, and Broadley observes that this was a large square mound “three hundred feet to the south of the village.”<sup>77</sup> However, neither of them appears to have noticed the remains of the similarly shaped but at least thirty-six times larger feature of F9, on top of which Kamgar Khan’s mound sits.

The protrusions on the northwest, northeast, and southeast ends of F9 are of similar shape and dimension. Figure 9 shows the outline of the mound as a dotted line and illustrates four shapes consistent with this outline that could resemble the ground plan of the buried structure. The protrusions could correspond to bastions of a fort (as suggested by Figs. 9a and 9b), but the corners of F9 seem to stretch out farther than would the semicircular or angular bastions of a fort. Their size is more consistent with small structures, perhaps stupas, one at each corner (either round, as in Fig. 9c, or square, as in Fig. 9d), separated from the large central square. The debris of collapsed structures could have formed heaps, uniting the isolated structures in the corners with the main square in the middle. Buchanan noted the presence of four heaps to the south of Kamgar Khan’s fort, which he suggested were separate buildings.<sup>78</sup> He also found two Jain images on the easternmost of the four heaps, which may have been at the location of the current Jain temple (Fig. 10). However, two of the three remaining heaps observed by Buchanan might correspond to the southwest and southeast stupas hypothesized above, flanking the central square (see Fig. 10).<sup>79</sup> Broadley noticed “two small Buddhist topes, some fifty feet in circumference and not more than six or eight feet high” to the south of the Kamgar Khan

mound,<sup>80</sup> which might also be a reference to these two southern stupas. The southwest corner of F9 does not conform to the shape of the other three corners. This may be due to other archaeological structures or subsequent constructions built close to this corner, the debris of which would have formed additional heaps obscuring the shape. An indicative boundary of the southwest corner of F9 is marked as a thinner dotted line in Figure 9 and Figure 10c.

#### *Similarities with Known Archaeological Sites*

A careful examination of the angles at which the three clearly defined corners of F9 radiate outward suggests that the overall structure’s orientation is rotated clockwise by a few degrees. For instance, the eastern wall of the hypothesized structure F9 (see Fig. 9a–d) is tilted a few degrees east relative to true north. The shape and dimensions of the mound suggest that structure within was square-shaped, and large enough to comfortably accommodate the vihara structures of both Vikramasila and Somapura, which are tellingly oriented in a similar way. Both monasteries were founded by Dharmapala in the eighth or early ninth century CE.<sup>81</sup> Their ground plans are almost identical, each with a large quadrangle structure consisting of a vihara and a cruciform stupa in the center. Vikramasila (coordinates 25°19′26.36″N and 87°17′05.06″E), with 330 cells in the vihara structure, is slightly larger than Somapura (coordinates 25°01′51.92″N and 88°58′36.47″E), which had 117 cells. The main difference in the two vihara structures is that the outer wall of Vikramasila is dotted with semicircular bastions at regular intervals, giving it the outward appearance of a fort, whereas Somapura’s wall seems to have been plain.<sup>82</sup> These differences are clearly noticeable on Google Earth images (Figs. 10a, 10b).

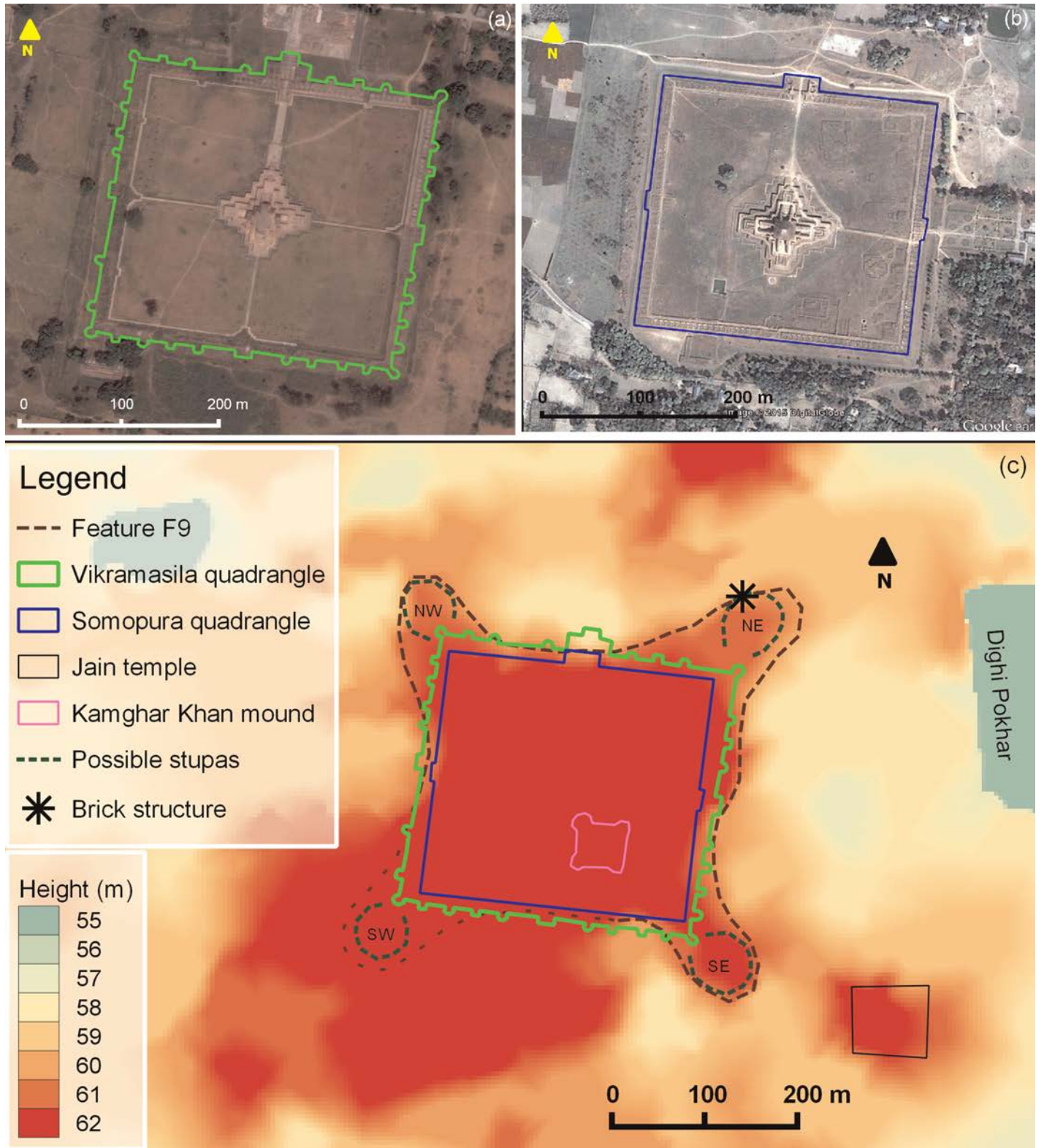

FIG. 10. (a) Google, DigitalGlobe image of Vikramasila Mahavihara; (b) Google, DigitalGlobe image of Somapura Mahavihara; (c) DEM (5m resolution) showing the northern mound with the outlines of Vikramasila and Somapura (shown to scale) superimposed for comparison of size, shape, and orientation.



Despite these differences, the size, shape, and orientation of F9 suggest that the large structure buried under Begumpur is comparable to Vikramasila and Somapura.

### *A Field Study*

A field exploration was undertaken on January 9, 2014, to seek evidence for feature F9, which measures 450 meters (northeast to southeast corners) by 400 meters (northwest to northeast corners), but whose elevation is only around 4–5 meters higher than the surrounding area. It was appropriate to search for undulated surfaces or exposed old walls along the periphery of this feature rather than in the middle. As can be seen in Figure 6, the northern sections of feature F9, including its northeastern and northwestern corners lie below a settlement (Begumpur) or very close to it. The southeast corner, being agricultural land, was therefore the most promising starting point. This area was explored carefully using GPS navigation but nothing remotely indicative of a feature like F9 was observed. The residents of the village, who were curious about the purpose of the study, were very forthcoming with information. When asked if there had been any excavations in the vicinity, or if there were any exposed old structures, they indicated that there had been a large excavation at Kamgar Khan's mound about 6–8 years earlier. One resident reported that a small trench was recently dug on his land where part of a brick structure was found and offered to lead us there.<sup>83</sup> As we followed him, our GPS track traced northward (along the main road that lies east of Kamgar Khan's mound), then eastward, and ended by the trench located almost precisely at the northeast corner of F9. Figures 6 and 10c show the location of the excavated brick structure (labeled with an asterisk) in the context of the larger feature F9. The owner volunteered information that this piece of land, now about 8 feet deeper than adjacent parcels, had a surface level with the surroundings and had been left fallow for some time. The topsoil had become hard and therefore was unable to retain water for cultivation. In order to improve the soil fertility, the owner employed an earth-mover to remove the topsoil and plow the land for cultivation. While executing this activity, the earth-mover encountered some bricks. When this was reported, the authorities excavated a small trench that revealed the brick structure shown in Figure 11a.<sup>84</sup> Figure 11a is a photograph of the brick structure in the excavated trench and Figure 11b shows the plot where the excavation was done. The location of the brick structure in the plot is labeled with a roundel in Google Earth images

of three different dates (Fig. 11c–e). The information given by the owner is consistent with surface activity observable from Google Earth images of various dates. Figure 11c (November 21, 2006) shows that the plot has an even surface texture and tone, with pale, regular stripes running north-south, indicating cultivation. The parcels to the northwest and southeast have similar signatures. Figure 11d (May 8, 2010) shows a rough surface texture without stripes, which indicates scrubland. Figure 11e (November 23, 2013) was taken only forty-seven days before our field visit. It clearly shows the plot stripped of topsoil, with a circular earthen mound at the center to support a lamppost (Fig. 11b). No further archaeological excavations had been conducted, and a subsequent stay order has barred the owner from using the land for cultivation for nearly a year. This plot has excellent potential for a survey using GPR, especially because it has been flattened, the surface activity is minimal, and one knows there is a structure underneath.

### **One Establishment or Two?**

The gap between the northern and southern mounds was noticed by Buchanan in 1812. As stated earlier, he says Dighi Pokhar marks the commencement of ruins and refers to the Begumpur mound as “considerable space elevated with fragments of brick.” Proceeding further, he notes: “South of this mass of building has been another much more considerable, on the north end of which is situated the village of Baragung.”<sup>85</sup> Therefore, Buchanan did observe that the ruins were in two large groups, and the southern group was the larger of the two.<sup>86</sup>

Two pieces of evidence in the layout of Nalanda are consistent with the theory that the northern mound was part of a single Nalanda complex. First, the northern mound falls within the suggestive cluster of water bodies that appear to surround Nalanda. Second, consider two imaginary lines: one joining the entrances of temples 12–14 and another joining the entrances of monasteries 1, 4, and 6–11 (see Fig. 6). If these two nearly parallel lines are extended northward, the center of feature F9 lies almost perfectly in between them. This suggests preconceived planning in laying out the structure F9 in order to align it with the other, perhaps older, structures on the southern mound. This alignment, unless coincidental, would have been unnecessary if the establishment on the northern mound were separate or independent of the main Nalanda complex. However, the dimensions of the structure F9 and the layout of its floor plan



FIG. 11. (a) The brick structure recently excavated in Baragaon; (b) the plot where the brick structure was found; (c), (d) Google, DigitalGlobe, and (e) CNES/Astrium images of the plot on three different dates. The brick structure is marked as a roundel, and the northeast corner of F9 is marked as a dotted line.

(which suggests a large quadrangle) are inconsistent with the much smaller structures in the Nalanda complex farther south, which lie in regularly spaced rows running south-north.

In support of the alternative theory, observe that the shortest distance between the two mounds is around 300 meters, and the exact distance between archaeological remains buried in these mounds could be even more. For instance, if we suppose that the northernmost part of the main Nalanda complex is the brick mound marked F3 in Baragaon (Figs. 6, 7), the distance from F3 to the northern mound containing F9 is around 500 meters. This gap between the two mounds seems to

be too large if the northern mound was part of the Nalanda complex.

#### *Evidence for Odantapuri*

Could the structure F9 on the northern mound be the celebrated Pala period monastery Odantapuri (or Uddandapura)? This site is known to have been in Nalanda's vicinity, but no location for it has been conclusively established. The historical record is limited and of questionable accuracy, but we present it here and note that much of it is consistent with our hypothesis that structure F9 corresponds to Odantapuri. One of

the monastic seals found in Nalanda contains the name Uddandapura.<sup>87</sup> The Tibetan historian Taranatha (whose account was written in 1608 CE and whose sources are unclear) notes that this monastery was built during the reign of the first Pala king, Gopala,<sup>88</sup> which was around the middle of the eighth century CE. The architectural plan of Odantapuri is said to have been based on the concept of the Buddhist universe with Mount Meru (or Sumeru) at the center and four “continents” around it.<sup>89</sup> It is possible, therefore, that the archaeological remains protruding at the corners of F9 were representations of these four continents. Patil states that around the eleventh century CE, while Nalanda was struggling for survival, Odantapuri “had a rival institution functioning under the royal patronage of Palas and, being a capital town, it must have inevitably snatched away the fortunes of Nalanda.”<sup>90</sup> Taranatha wrote that, during the time of the four Sena kings (twelfth century CE<sup>91</sup>), the number of foreigners, including Muslims, increased in the region and “To protect Odantapurī and Vikramaśīla, the king even converted these partially into fortresses and stationed some soldiers there.”<sup>92</sup> This perhaps explains the semicircular bastions on the outer wall of Vikramasīla’s vihāra quadrangle (see Fig. 10a). The medieval chronicle *Tabakat-i-Nasiri* mentions that in 1197 troops led by Ikhtiyar-ud-Din Muhammad destroyed what they believed was a fort and killed all the inmates, only later realizing that the place was not a fort but a vihāra.<sup>93</sup> It is believed that this vihāra was Odantapuri.<sup>94</sup> However, Odantapuri is identified with Bihar Sharif (which is 10 kilometers northeast of F9), based on the older name of the latter—Dand Bihar or Bihar Dandi.<sup>95</sup> Many Buddhist images and carvings have been found in Bihar Sharif,<sup>96</sup> and Buchanan recorded numerous brick and stone remains there.<sup>97</sup> A brass image inscription mentioning the name Uddandapura was also found in this town.<sup>98</sup> However, very little excavation has been conducted in Bihar Sharif, and no investigation has revealed a large structure comparable to a Pala vihāra.

The records of the Tibetan monk Dharmaswamin, who was at Nalanda during the Muslim invasion, indicate that Odantapuri was in close proximity to Nalanda, but the distances and directions he mentions are inconsistent. In one instance he says Odantapuri is a half-day’s march from Nalanda (which is true for Bihar Sharif), but he also estimates the distance as one yojana (approximately one mile) in some places (which is consistent with Begumpur) and seven yojanas in others.<sup>99</sup> An inscription found in Gaya mentions that Gaya was located in “Uddandapura dese”<sup>100</sup> (the region or district of Uddandapura), which suggests that the name Uddan-

dapura referred to a larger area or a district.<sup>101</sup> The vihāra bearing that name could therefore have been anywhere within the district—in which case both Bihar Sharif and Begumpur are probable candidates.

This study does not seek to conclusively establish the location of Odantapuri, but merely suggests an alternative location for it (while recognizing that Bihar Sharif remains an equally likely candidate) or, at the very least, that feature F9 could be yet another Pala monastery. Taranatha mentioned that Gopala “built the Nalendra *vihāra* near Odantapurī,”<sup>102</sup> which offers another theory for F9.

The anomaly in the layout of Dighi Pokhar and the presence of the palaeochannel that supplied Dighi with water drawn from the river Panchana have already been discussed. As can be seen in Figure 6, Dighi Pokhar is more directly aligned with the northern mound than with the ruins farther south. If there had been a large monastery at the location F9, as hypothesized, it is likely that the excavation of the largest tank, Dighi Pokhar, and the diversion of water from Panchana toward Dighi, was engineered in order to supply water to this establishment.

The presence of the large monastery on the northern mound cannot be fully established unless excavation or noninvasive GPR survey is undertaken on a massive scale. This could be a complicated task, as a large portion of F9 lies beneath the village of Begumpur. However, the southern half of F9 and its northern periphery lie largely under cultivated land and a thorough exploration would be possible there.

The brick structure seen in Figure 11a is likely part of the base or foundation of the protruding structure at the northeast corner of F9 (Fig. 10c). The excavated trench is very small and does not reveal the shape or layout of the structure. The field survey undertaken as part of the present study was very minimal, with the specific goal of finding some evidence for remains of an archaeological structure at the periphery of feature F9. The fact that some excavated brickwork was found at a location coinciding with the boundary of the hypothesized structure F9 supports the belief that there could be similar brickwork all along the periphery. A more thorough exploration should be undertaken by archaeologists to support or refute this hypothesis. The maps produced by this study could guide that effort.

## Conclusions

This study has identified several features that are of archaeological interest in the environs of Nalanda, using satellite images:

1. A pattern of water bodies surrounds Nalanda, possibly indicating the site's extent and spread in a primarily north-south direction. This provides further evidence for the belief that archaeological remains at Nalanda are spread over a significantly larger region than the area excavated, owned, and protected by the ASI.

2. Vegetation patterns indicate that along the line of temples 3, 12, 13, and 14 there might have been two additional temples to the north (F1 and F2 in Fig. 7a) and one additional temple to the south (F4 in Fig. 8). Similarly, on the south of the main row of monasteries a possible extension indicates there might have been three or four more monasteries (F5 in Fig. 8).

3. The northern mound reveals a shape that suggests possible hidden remains of a large four-pointed structure (Figs. 6 and 10c). This could be a monastery architecturally similar to Vikramasila and Somapura, as it resembles the latter two in size, shape, and orientation. It is speculated that this could be the site of the celebrated Odantapuri or another significant Pala monastery. A field expedition has revealed that the location of a brick structure excavated recently in Begumpur coincides with the northeast corner of the four-pointed sub-surface structure. This suggests that such buried brick structures could exist all along the periphery of the four-pointed structure in the northern mound.

## Future Directions

The area around Nalanda has multiple types of features: tanks, settlements, agricultural land, excavated areas, and unexcavated mounds. The archaeological remains themselves are spread across a large region of this complex landscape, so it is invaluable to have an overall perspective in order to view these features simultaneously in the context of the larger environment. Remote sensing images are capable of providing such synoptic views, with the additional ability to “see” in wavelengths certain kinds of archaeological features that are less discernible in visible light. The Nalanda region has much scope for further remote sensing and GIS analysis, even with the kinds of images already used in this study (optical, infrared, and 3D). It is quite possible that additional features may be revealed by analyzing images from dates covering a wider range of weather conditions, or from images taken by radar/hyperspectral/LiDAR technology and other emerging technologies. A GPR survey could be undertaken on selected locations, with the plot in Begumpur being extremely promising. All available maps (made by Buchanan, Kittoe, Broadley, Cunningham, ASI, and others) can be integrated into a GIS database as individual layers so that features marked

in them can be spatially analyzed. Archaeological findings can also be geo-tagged and spatially analyzed. Such a database would allow images to be reanalyzed in light of each new layer, and would be a valuable asset for subsequent research on this fascinating site.

*M. B. Rajani is Assistant Professor in the School of Humanities at the National Institute of Advanced Studies, Bangalore, India. Her research interests are in the field of landscape archaeology. She is currently writing a book for archaeological researchers on using Remote Sensing and GIS technologies to supplement traditional investigative methods. [mbrajani.nias@gmail.com]*

## Notes

I thank the new Nalanda University for granting a nine-month fellowship to support the commencement of this research, and for providing opportunities to discuss and disseminate results via a workshop, a conference, and three colloquia. I thank the Karnataka State Remote Sensing Applications Centre (KSRSAC) Bangalore for providing access to lab facilities for conducting satellite data analysis. I thank Prof. Fredrick Asher and Dr. Mary Stewart for their input during discussions, and Dr. John Marr for providing valuable reference material. I thank Prof. Donald Lopez for consulting original Tibetan sources to check the accuracy of translations for selected pages of Dharmasvamin's accounts. I thank Prof. Max Deeg for insights into Xuanzang's translations. Finally, I thank the reviewers of this article, whose insightful comments have helped me enhance the scope of the paper.

1. The area has multicultural importance. The name Nalanda refers to the famous Buddhist monastery, but the region is rich with Jain and Hindu antiquities too.

2. The established chronology is problematic as the site may have had a longer antiquity going back to the Maurya Period. B. R. Mani, “Excavations of Stupa Site No. 3 at Nalanda and Early Chronological Evidence,” in *The Heritage of Nalanda*, ed. C. Mani (New Delhi: Aryan Books International, 2008), 13–22.

3. D. R. Patil, *The Antiquarian Remains in Bihar*, Historical Research Series 4 (Patna: Kashi Prasad Jayaswal Research Institute, 1963), 303.

4. George Roerich, trans., *Biography of Dharmasvamin (Chag lo tsa-ba Chos-rje-dpal), a Tibetan Monk Pilgrim* (Patna, India: K. P. Jayaswal Research Institute, 1959), xlii, 93–94.

5. Janice Leoshko, *Sacred Traces: British Explorations of Buddhism in South Asia* (Aldershot, Hants, England; Burlington, VT: Ashgate, 2003), 10.

6. Samuel Beal, trans., *Si-yu-ki: Buddhist Records of the Western World*, 2 vols. (London: Kegan Paul, Trench, Trübner, 1884) (1906 ed., vol. 2, available online: <http://archive.org/details/siyukibuddhistroobealgoog>); Samuel Beal,

- trans., *The Life of Hiuen-Tsiang by the Shaman Hwui Li, with an Introduction Containing an Account of the Works of I-Tsing* (London: Kegan Paul, Trench, Trübner & Co., 1888) (1914 popular ed., available online: <http://archive.org/details/lifeofhiuentsiano30569mbp>); J. W. Laidlay, trans., *The Pilgrimage of Fa Hian, from the French Edition of the Foe Koue Ki of MM. Rémusat, Klaproth, and Landresse, with Additional Notes and Illustrations* (Calcutta: Printed by J. Thomas, Baptist Mission Press, 1848), <https://archive.org/details/pilgrimagefahiaoormgoog>; J. Takakusu, trans., *A Record of the Buddhist Religion as Practised in India and the Malay Archipelago (A.D. 671–695)*, by I-Tsing (Nan-ae-ki-kwei-niu-fa-ch'uen) (Oxford: Clarendon Press, 1896), <https://archive.org/details/arecordbuddhistootakagoog>; Li Rongxi, trans., *The Great Tang Dynasty Record of the Western Region*, by Xuanzang, BDK English Tripitaka 79 (Berkeley, CA: Numata Center for Buddhist Translation & Research, 1996).
7. Laidlay, *The Pilgrimage of Fa Hian*; Beal, *Si-yu-ki*.
  8. Upinder Singh, *The Discovery of Ancient India: Early Archaeologists and the Beginnings of Archaeology* (Delhi: Permanent Black, 2004), 1–22.
  9. V. H. Jackson, ed., “Journal of Francis Buchanan (Patna and Gaya Districts),” *The Journal of the Bihar and Orissa Research Society* 8, pt. 3–4 (1922): 266–73, <https://archive.org/details/journalofbiharre08bihauoft>.
  10. Laidlay, *The Pilgrimage of Fa Hian*.
  11. Diwakar Kumar Singh, “Sacred Sites and Sacred Identities: A Study of Nalanda and Its Vicinity (c. 600–1200 A.D.),” M.Phil. diss., University of Delhi, India, 2010, 43–44.
  12. Beal, *Si-yu-ki*, 168; Shaman Hwui Li, *The Life of Hiuen-Tsiang*, popular ed., introduction by Samuel Beal (London: K. Paul, Trench, Trübner, 1914), 110, <https://archive.org/details/lifeofhiuentsiano30569mbp>; Li Rongxi, *The Great Tang Dynasty Record of the Western Region*, 281.
  13. Alexander Cunningham, *Archaeological Survey of India*, vol. I: *Four Reports Made During the Years 1862–63–64–65* (Simla: Printed at the Government Central Press, 1871), 28, pl. XVI, <https://archive.org/details/reportoocunngoog>.
  14. In 1871 he became the first Director General of the ASI.
  15. James Fergusson, “On Hiouen-Thsang’s Journey from Patna to Ballabhi,” *Journal of the Royal Asiatic Society of Great Britain & Ireland* (new series) 6, no. 2 (July 1873): 213–74; A. M. Broadley, “On the Identification of Various Places in the Kingdom of Magadha Visited by the Pilgrim Chi-Fa-Hian (A.D. 404–415),” *The Indian Antiquary* 1, pt. I–III (1872): 18–21, 67–74, 106–110, also quoted in Leoshko, *Sacred Traces*, 44, 61, 69.
  16. Leoshko, *Sacred Traces*, 46.
  17. Vincent Smith, *General Index to the Reports of the Archaeological Survey of India*, vols. I–XXIII (Calcutta, 1887), quoted in Singh, *The Discovery of Ancient India*, 343.
  18. Singh, *The Discovery of Ancient India*, 347.
  19. Ibid.
  20. Dilip K. Chakrabarti, *A History of Indian Archaeology from the Beginning to 1947* (1988; repr., New Delhi: Munshiram Manoharlal Publishers, 2001), 115–16.
  21. Cunningham, *Archaeological Survey of India*, vol. I.
  22. Ibid., 28, pl. XVI.
  23. Excavated under the superintendence of Captain Marshall (1863): Cunningham, *Archaeological Survey of India*, vol. I, 33; A. M. Broadley (1871–72): Alexander M. Broadley, “The Buddhist Remains of Bihar,” *Journal of Asiatic Society of Bengal* 41 (1872): 299–312; David Brainard Spooner (1915–19), Hirananda Sastri (1919–21), J. A. Page (1921–29), M. H. Kuraishi (1928–30), G. C. Chandra (1932–36), N. Nazim (1936–37), A. Ghosh (1937–38), and V. K. Misra, B. Nath, B. S. Jha (1973–83): Singh, “Sacred Sites and Sacred Identities,” 51–60.
  24. Cunningham, *Archaeological Survey of India*, vol. I, 28, pl. XVI.
  25. Ibid., 32–33.
  26. Jackson, “Journal of Francis Buchanan (Patna and Gaya Districts),” 269.
  27. MSS EUR/D87, p. 127, Asia and Africa Collections, British Library.
  28. Cunningham, *Archaeological Survey of India*, vol. I, 33.
  29. This mound was labeled “Y” in Cunningham’s sketch; Broadley called it “mound VII” and excavated it in 1872. Broadley, “The Buddhist Remains of Bihar,” 99–312.
  30. About this long interval, Diwakar K. Singh (“Sacred Sites and Sacred Identities,” 51) remarked: “Perhaps the reason was that after retirement of James Burgess as Director General of the ASI in 1889, archaeological surveyors of Bengal and Punjab were directed to close all field operations and the emphasis was laid on a large number of archaeological publications.”
  31. This expansion might have been due to availability of funds. Singh has elaborated on the details regarding various grants that ASI received during this period. Singh, “Sacred Sites and Sacred Identities,” 51–60.
  32. There are no known records of when Temple 14 was excavated. Its architectural features were mentioned on two occasions by A. Ghosh, who worked in the Archaeological Survey of India (ASI) from 1937 and rose to become Director General from 1953 to 1968, but he does not say when it was excavated. See A. Ghosh, ed., “Excavations at Alamgirpur,” *Indian Archaeology—A Review* (1958–1959): 92; and A. Ghosh, *A Guide to Nalanda* (Delhi: Manager of Publications, 1939), 19–20. Therefore, the dates of these two publications have been used for the graph in Fig. 2. The Sarai temple was excavated by V. K.

Misra, B. Nath, and B.S. Jha, 1973–83; Singh, “Sacred Sites and Sacred Identities,” 59.

33. Jackson, “Journal of Francis Buchanan (Patna and Gaya Districts),” 267.

34. L.S.S. O’Malley, comp., *Bengal District Gazetteers: Patna* (Calcutta: Bengal Secretariat Book Depot, 1907), 184–85.

35. Patil, *Antiquarian Remains in Bihar*, 328.

36. The social and religious nature of certain antiquities sometimes limits ASI in acquiring or retaining such assets. The nine-foot-tall black stone portrayal of Buddha in Baragaon, believed to have unique healing power and worshipped by local Hindus as Teliya Baba and by Thai pilgrims as Black Buddha, is one prominent example of this phenomenon (see Aruna Deshpande, *Buddhist India Rediscovered* [Ahmedabad: Jaico Publishing House, 2013]). The shrine is on the west of monastery 11 and southeast of temple 14; the cleft in the ASI boundary in this region, seen in Fig. 1, indicates exclusion of this shrine from the protected area since the worshippers fought legally for full access to and control over the shrine. See Suresh Bhatia, “Nalanda: The Other Side of Its History,” *The Buddhist Heritage*, October 1, 2009, [http://bhpromo.org.in/index.php?option=com\\_content&view=article&id=59&Itemid=65](http://bhpromo.org.in/index.php?option=com_content&view=article&id=59&Itemid=65) (accessed March 1, 2015). This image must have been prominently situated and frequently attended to as an object of worship, for all the early explorers encountered it. Buchanan recorded it as “Baituk Bairobh” (Jackson, “Journal of Francis Buchanan [Patna and Gaya Districts],” 269) and also marked in his sketch (see note 27), Cunningham referred to it as “Baithak Bhairav” (Cunningham, *Archaeological Survey of India*, vol. I, 35, marked “M” in his sketch), and Broadley as “Telia Bhandar” (Broadley, “The Buddhist Remains of Bihar,” 303).

37. Shaman Hwui Li, *The Life of Hiuen-Tsiang*, 112.

38. Takakusu, *A Record of the Buddhist Religion as Practised in India . . .*, 154.

39. Fredrick M. Asher, “India, Magadha, Nalanda: Ecology and a Premodern World System,” keynote address presented on January 8, 2014, at the Cultural Heritage: Environment, Ecology, and Inter-Asian Interactions conference held January 6–8, 2014, at Nalanda University in Rajgir.

40. Mary L. Stewart, *Nalanda Mahavihara: A Study of an Indian Pala Period Buddhist Site and British Historical Archaeology, 1861–1938*, BAR International Series 529 (Oxford: B.A.R., 1989); Bhaskaranatha Misra, *Nalanda*, 3 vols. (Delhi: B. R. Publishing, 1998); Le Huu Phuoc, *Buddhist Architecture* ([S.I.]: Grafikol, 2010).

41. John Bradford, *Ancient Landscapes: Studies in Field Archaeology* (London: G. Bell and Sons, 1957); D. R. Wilson, *Air Photo Interpretation for Archaeologists* (1982; 2nd ed., Stroud: Tempus, 2000).

42. M. B. Rajani and K. Kasturirangan, “Multi-spectral Remote Sensing Data Analysis and Application for Detecting Moats around Medieval Settlements in South

India,” *Journal of the Indian Society of Remote Sensing* 42, no. 3 (September 2014): 651–57, <http://link.springer.com/article/10.1007%2F12524-013-0346-4>; M. B. Rajani, “Bangalore from Above: An Archaeological Overview,” *Current Science* 93, no. 10 (2007): 1352–53; Athos Agapiou and Diofantos G. Hadjimitsis, “Vegetation Indices and Field Spectroradiometric Measurements for Validation of Buried Architectural Remains: Verification Under Area Surveyed with Geophysical Campaigns,” *Journal of Applied Remote Sensing* 5, no. 1 (published online September 26, 2011, doi:10.1117/1.3645590).

43. Julia Shaw and John Sutcliffe, “Ancient Dams, Settlement Archaeology and Buddhist Propagation in Central India: The Hydrological Background,” *Hydrological Sciences Journal* 48, no. 2 (2003): 277–291, doi:10.1623/hysj.48.2.277.44695; Julia Shaw and John Sutcliffe, “Ancient Dams and Buddhist Landscapes in the Sanchi Area: New Evidence on Irrigation, Land Use and Monasticism in Central India,” *South Asian Studies* 21, no. 1 (2005): 1–24, doi:10.1080/02666030.2005.9628641; Julia Shaw, *Buddhist Landscapes in Central India: Sanchi Hill and Archaeologies of Religious and Social Change, c. Third Century BC to Fifth Century AD* (London: British Association of South Asian Studies, 2007).

44. Shaw and Sutcliffe, “Ancient Dams, Settlement Archaeology and Buddhist Propagation in Central India,” 271.

45. Lars Fogelin, *Archaeology of Early Buddhism*, *Archaeology of Religion* 4 (Lanham, MD: AltaMira Press, 2006), 136.

46. Robin Coningham, Prishanta Gunawardhana, Mark Manuel, Gamini Adikari, Mangala Katugampola, Ruth Young, Armin Schmidt, K. Krishnan, Ian Simpson, Gerry McDonnell, and Cathy Batt, “The State of Theocracy: Defining an Early Medieval Hinterland in Sri Lanka,” *Antiquity* 81, no. 313 (September 2007): 699–719.

47. A. Beck, J. Shaw, and D. Stott, “Best Practice Approaches for Applying Satellite Imagery for Landscape Archaeological Applications: A Case Study from the World Heritage Site of Sanchi, India,” *Proc. SPIE (Remote Sensing for Environmental Monitoring, GIS Applications, and Geology VII, 674905)* 6749 (October 29, 2007), doi:10.1117/12.737553.

48. M. B. Rajani and A. S. Rajawat, “Potential of Satellite Based Sensors for Studying Distribution of Archaeological Site along Palaeo Channels: Harappan Sites, a Case Study,” *Journal of Archaeological Science* 38, no. 9 (September 2011): 2010–16, doi:10.1016/j.jas.2010.08.008.

49. Mandyam B. Rajani, Satadru Bhattacharya, and A. S. Rajawat, “Synergistic Application of Optical and Radar Data for Archaeological Exploration in the Talakadu Region, Karnataka,” *Journal of the Indian Society of Remote Sensing* 39, no. 4 (December 2011): 519–27, <http://link.springer.com/article/10.1007%2F12524-011-0102-6>.

50. <http://landsatlook.usgs.gov/>.

51. As of February 6, 2014; images get added to this list every few days or weeks.
52. Rajani and Kasturirangan, "Multispectral Remote Sensing Data Analysis and Application for Detecting Moats around Medieval Settlements in South India."
53. As in the case of the northern section of the moat in Halebidu. See *ibid.*, fig.4e.
54. Misra, *Nalanda*, 1:170.
55. Patil, *Antiquarian Remains in Bihar*, 307.
56. D. Anand, <http://nalanda-insatiablenoffering.blogspot.in/2009/07/current-situation-of-nalanda-mahavihara.html> (accessed March 21, 2014).
57. J. Kamini, Malatesh Kulkarni, V. Raghavaswamy, P. S. Roy, and P. K. Mishra, "CARTOSAT-1 Views the Nalanda Buddhist ruins," *Current Science* 93, no. 2 (July 2007): 136.
58. Cartosat1 (also known as IRSP5) is a satellite in the Indian Remote sensing Satellite (IRS) series. It has two on-board cameras that view Earth, both in Panachromatic band but in different angles (fore: +26° and aft: -5°) thus producing a stereo pair; the aft image is used here for image interpretation. The date of the image used for this study is February 29, 2008.
59. Shaw, *Buddhist Landscapes in Central India*; Julia Shaw and John Sutcliffe, "Ancient Dams and Buddhist Landscapes in the Sanchi Area."
60. SRTM DEM download link: <http://srtm.csi.cgiar.org/SELECTION/inputCoord.asp>.
61. The DEM covering the study area was corrected to a higher precision using anaglyph images in the software ERDAS LPS Photogrammetry Suite.
62. All three from the satellite RESOURCESAT1 (also known as IRSP6), sensor: LISS IV.
63. Patil, *Antiquarian Remains in Bihar*, 307.
64. Jackson, "Journal of Francis Buchanan (Patna and Gaya Districts)," 268; Cunningham, *Archaeological Survey of India*, vol. I, 34; Alexander M. Broadley, *Ruins of the Nālanda Monasteries at Burgāon, Subdivision Bihār, Zilla Patna* (Calcutta: Bengal Secretariat Press, 1872), 5; Broadley, "The Buddhist Remains of Bihar," 303.
65. Misra, *Nalanda*, 1:169.
66. Jackson, "Journal of Francis Buchanan (Patna and Gaya Districts)," 271; Cunningham, *Archaeological Survey of India*, vol. I, 34-55; Broadley, *Ruins of the Nālanda Monasteries at Burgāon*, 6-7, and Broadley, "The Buddhist Remains of Bihar," 4.
67. The full act is available online at [http://Asi.nic.in/pdf\\_data/5.pdf](http://Asi.nic.in/pdf_data/5.pdf) (accessed December 31, 2015).
68. Cunningham, *Archaeological Survey of India*, vol. I, 28, pl. XVI.
69. *Ibid.*, 34-35.
70. I thank Dinesh Mehta for this photograph.
71. I thank Deepak Anand for the information about the sculpture inside this structure.
72. Stewart, *Nalanda Mahavihara*.
73. Cunningham, *Archaeological Survey of India*, vol. I, 28, pl. XVI.
74. The measurements of F6, F7, and F8 mentioned here are approximate. Their heights have not been measured physically.
75. Jackson, "Journal of Francis Buchanan (Patna and Gaya Districts)," 266-67.
76. *Ibid.*, 267.
77. Cunningham, *Archaeological Survey of India*, vol. I, 28, pl. XVI; Broadley, *Ruins of the Nālanda Monasteries at Burgāon*, 4.
78. Jackson, "Journal of Francis Buchanan (Patna and Gaya Districts)," 267.
79. At present there is another Jain temple in the location of the protrusion at the southeast corner.
80. Broadley, *Ruins of the Nālanda Monasteries at Burgāon*, 4.
81. James C. Harle, *The Art and Architecture of the Indian Subcontinent*, 2nd ed. (New Haven, CT: Yale University Press, 1994), 204.
82. Faruque Hasan, *The Making and Symbolism of Paharpur Stupa* (Lulu.com, 2010), 8, pl. 1; Harle, *The Art and Architecture of the Indian Subcontinent*, 204.
83. I thank people of the neighboring villages, especially Begumpur, for being very forthcoming with information. My special thanks to the owner of the plot in Begampur. I thank Mr. Anil Jha from Nalanda University, Rajgir, for accompanying me on the field visit and aiding in discussions with local residents, and our driver, Rajesh Kumar.
84. It was not clear from the information provided by the owner of the plot whether the authorities who excavated were from ASI or Bihar's State Archaeology Department.
85. Jackson, "Journal of Francis Buchanan (Patna and Gaya Districts)," 267.
86. Buchanan also captures this in his sketch referred to earlier. MSS EUR/D87, p. 127, part of the Asia and Africa Collections, British Library.
87. Monastic seals usually contain the name of the monastery and the assemblage of monks who issued it. Hiranand Sastri identified one from Nalanda that referred to Uddandapura, which he correlated with Bihar Sharif. It reads: *Śrimad-Uddandapura-śrī-Bodhisatvāgama-Mahāvihārīy-ārya-bhikṣusanghasya*. Hirananda Sastri, "Nalanda and Its Epigraphic Material," *Memoirs of the Archaeological Survey of India*, Archaeological Survey of India 66 (1942; repr. New Delhi, 1999), 175.
88. *Tāranātha's History of Buddhism in India*, trans. Lama Chimpa and Alaka Chattopadhyaya, ed. Debiprasad Chattopadhyaya (Delhi: Motilal Banarsidass Publishers, 1990), 262.
89. *Ibid.*, 264. The earliest Buddhist monastery in Tibet, Samye, is said to have been modeled on Odantapuri Vihara. Geoffrey Samuel, *The Origins of Yoga and Tantra: Indic Religions to the Thirteenth Century* (Cambridge: Cambridge

University Press, 2008), 307–8; Françoise Pommaret, *Lhasa in the Seventeenth Century: The Capital of Dalai Lamas*, Brill's Tibetan Studies Library 3 (Leiden, Netherlands: Brill, 2003), 165; Ram Rahul, *March of Central Asia* (New Delhi: Indus Publishing Co., 2000), 33. Samye has four Chorten (or stupa) at the four sub-cardinal directions outside the central square monastery structure. The current structures in Samye are modern, but they are built along the old layout. In one of the buildings is an old mural painting that depicts what the old monastery looked like. A photograph of this mural can be found online at <https://www.flickr.com/photos/eriktorner/9763639613/in/photostream/> (accessed May 30, 2014).

90. Patil, *Antiquarian Remains in Bihar*, 326.

91. The dating of these reigns is given in Vincent A. Smith, *The Early History of India from 600 B.C. to the Muhammadan Conquest: Including the Invasion of Alexander the Great*, 3rd ed., rev. and enl. (1914; New Delhi: Atlantic Publishers, 1999), 421.

92. *Tāranātha's History of Buddhism in India*, 318.

93. *Tabakat-i-Nasiri: A General History of the Muhammadan Dynasties of Asia, including Hindustan, from A.H. 194 [810 A.D.], to A.H. 658 [1260 A.D.], and the Irruption of the Infidel Mughals into Islam*, trans. Major H. G. Raverty, 2 vols. (London: Printed by Gilbert & Rivington, 1881), 1:552.

94. Patil, *Antiquarian Remains in Bihar*, 326.

95. J. D. Beglar, *Archaeological Survey of India*, vol. VIII: *A Tour through the Bengal Provinces in 1872–73* (Calcutta, 1878), 75–76; Alexander Cunningham, *Archaeological Survey of India*, vol. XI: *Tours in the Gangetic Provinces from Badaon to Bihar in 1875–76 and 1877–78* (Calcutta, 1880), 185; Patil, *Antiquarian Remains in Bihar*, 45–46.

96. Patil, *Antiquarian Remains in Bihar*, 45; Mohammad Hamid Kuraishi, *List of Ancient Monuments Protected under Act VII of 1904 in the Province of Bihar and Orissa*, Archaeological Survey of India, New Imperial Series 51 (Calcutta: Government of India, Central Publication Branch, 1931), 55.

97. Jackson, “Journal of Francis Buchanan (Patna and Gaya Districts),” 263.

98. Sastri, “Nalanda and Its Epigraphic Material,” 2.

99. Roerich, *Biography of Dharmasvamin*, 93.

100. Alexander Cunningham, *Archaeological Survey of India*, vol. III: *Report for the Year 1871–72* (Calcutta: Office of the Superintendent of Government Printing, 1873), 128–29, <http://books.google.co.in/books?id=-wk3AQAAMAAJ&printsec=frontcover#v=onepage&q&f=false>.

101. F. Kielhorn, “Gaya Stone Inscription of the Reign of Sultan Firuz Shah: The Vikrama Year 1429,” *Indian Antiquary* 20 (September 1891): 312.

102. *Tāranātha's History of Buddhism in India*, 258.