

We are IntechOpen, the world's leading publisher of Open Access books Built by scientists, for scientists

4,600

Open access books available

120,000

International authors and editors

135M

Downloads

Our authors are among the

154

Countries delivered to

TOP 1%

most cited scientists

12.2%

Contributors from top 500 universities



WEB OF SCIENCE™

Selection of our books indexed in the Book Citation Index
in Web of Science™ Core Collection (BKCI)

Interested in publishing with us?
Contact book.department@intechopen.com

Numbers displayed above are based on latest data collected.
For more information visit www.intechopen.com



Licensed Shared Access Evolution to Provide Exclusive and Dynamic Shared Spectrum Access for Novel 5G Use Cases

Juha Kalliovaara, Tero Jokela, Heikki Kokkinen and Jarkko Paavola

Additional information is available at the end of the chapter

<http://dx.doi.org/10.5772/intechopen.79553>

Abstract

This chapter studies the Licensed Shared Access (LSA) concept, which was initially developed to enable the use of the vacant spectrum resources in 2.3–2.4 GHz band for mobile broadband (MBB) through long-term static licenses. The LSA system was developed to guarantee LSA licensees a predictable quality of service (QoS) and exclusive access to shared spectrum resources. This chapter describes the development and architecture of LSA for 2.3–2.4 GHz band and compares the LSA briefly to the Spectrum Access System (SAS) concept developed in the USA. 5G and its new use cases require a more dynamic approach to access shared spectrum resources than the LSA system developed for 2.3–2.4 GHz band can provide. Thus, a concept called LSA evolution is currently under development. The novel concepts introduced in LSA evolution include spectrum sensing, short-term license periods, possibility to allocate spectrum locally, and support for co-primary sharing, which can guarantee the quality of service (QoS) from spectrum perspective. The chapter also describes a demonstration of LSA evolution system with spectrum user prioritization, which was created for Programme Making and Special Events (PMSE) use case.

Keywords: spectrum sharing, Licensed Shared Access (LSA), LSA evolution, PMSE, LTE, incumbents, 5G

1. Introduction

Demand for radio spectrum is constantly increasing as wireless services; especially, video streaming and emerging Internet of Things (IoT) are being adopted at an accelerating pace.

Mobile phones, laptops, and tablets are becoming more and more common, and the quality of available content and services is also increasing. This has resulted in rapid increases in the amount of traffic in mobile networks, and the increases are predicted to continue [1–3]. This presents extreme challenges for mobile communication systems, as there is a lack of new spectrum resources to be allocated for the growing number of connected devices, services, and users.

The wireless communication technologies themselves are approaching the fundamental theoretical limits of bandwidth efficiency, but simultaneously the frequency bands are exclusively licensed to different services which might not utilize all of their spectrum resources. Valuable spectrum resources can be left unexploited at different frequencies if the license owner does not use them at all times or at all locations. For example, several spectrum measurement campaigns covering frequencies up to 3 GHz state that the spectrum utilization rate is on the scale of 10–20% [4–6], and thus, most of the spectrum resources remain unused. It is necessary to utilize the existing frequency resources more efficiently to satisfy the growing demand for spectrum, but the current exclusive licensing methods do not allow this. Recent international studies have concluded that spectrum sharing will play a major role in maximizing the amount of available spectrum for wireless communication systems [7, 8].

The current exclusive spectrum licensing needs to be updated or replaced to enable spectrum sharing. In spectrum sharing, the users who currently hold an exclusive license to use a frequency band are called incumbents and are the primary users of the band. If the incumbents are using their spectrum resources inefficiently, their spectrum resources could potentially be shared with other users who could use the vacant spectrum resources at certain times or at certain locations where the license holder does not have any transmissions. Spectrum occupancy measurements have been proposed to find candidate frequency bands for spectrum sharing [4]. The vacant spectrum resources could be utilized through dynamic spectrum access methods, such as opportunistic spectrum access (OSA) [9] or Licensed Shared Access (LSA) [10]. In OSA, the shared spectrum user chooses the best available vacant transmission channel in an opportunistic and dynamic manner as an unlicensed secondary user of the spectrum, who does not need a license but does not have any guarantees on the amount and quality of available spectrum and has no protection from any harmful interference.

Cognitive radio spectrum sharing can be divided into three different types: underlay, overlay, and interweave. In underlay spectrum sharing, the cognitive users are allowed to operate if the interference they cause to the incumbents is below a given level. In overlay spectrum sharing, the cognitive user needs to know the incumbent signal. The cognitive user then adds its own data to the incumbent data and transmits the combined signal. In interweave spectrum sharing, the cognitive radios exploit spectral holes. The spectral holes are spectrum which is not used to be the incumbent in time, frequency, or spatial dimension. In each of the cognitive spectrum sharing types, accurate spectrum sensing data are of paramount importance both to guarantee the protection of the incumbents and to maximize the capacity available for the cognitive users. The currently standardized LSA belongs to interweave category, typically uses static vertical long-term spectrum leasing, and does not include spectrum sensing capabilities.

In LSA, vacant spectrum resources can be leased to shared spectrum users, known as LSA licensees, who are guaranteed an exclusive access to the leased spectrum resources and are

protected from harmful interference. The incumbents are also protected from interference and might receive economic benefits from leasing their underutilized spectrum resources. The traffic load of the incumbent (licensed) users in LSA does not affect the performance of the LSA licensees, as the LSA licensees' transmissions are restricted so that they do not cause harmful interference to the incumbents under any circumstances. The terminology and definitions for shared spectrum access methods are diverse, but OSA and LSA could be considered as the two main categories in frequency bands with existing incumbents. Regardless of the used shared spectrum access method, it is essential to guarantee that the incumbents currently present in the band are protected from any harmful interference that could be induced by the newly introduced shared spectrum users.

The future LSA evolution will enable spectrum sensing and thus more dynamic use of spectrum. The current control solutions for network coordination are insufficient for heterogeneous 5G networks, where the performance of dense deployments could be further enhanced by advanced spectrum sharing [11]. 5G-PPP project called COHERENT considers the novel methods for coordinated control and spectrum management for 5G heterogeneous networks in LSA evolution.

Section 2 describes the development and architecture of LSA system for 2.3–2.4 GHz band. Section 3 discusses the feasibility, current status, and evolution of LSA toward 5G and makes a comparison to Spectrum Access System (SAS) concept developed in the USA. Section 4 describes an LSA evolution PMSE use case trial. Section 5 discusses the use of LSA evolution in 5G networks, and Section 6 gives the concluding remarks.

2. Development and architecture of LSA for 2.3–2.4 GHz band

The development of LSA concept began in European regulation and standardization to create a method for the mobile network operators (MNOs) to deploy their networks into bands allocated for mobile broadband (MBB), which currently have incumbents operating in the band. The concept allows spectrum sharing between an MNO and the incumbents with licensing conditions and rules that benefit both stakeholders. Radio Spectrum Policy Group (RSPG) proposed LSA concept [12] as an extension to an earlier proposal by an industry consortium, called Authorized Shared Access (ASA) [13]. ASA is limited to the International Mobile Telecommunications (IMT) use, while LSA can also be applied to other types of spectrum sharing. The 2.3 GHz band was chosen as the first frequency band for which to develop the operating conditions for LSA.

International Telecommunication Union Radiocommunication Sector (ITU-R) has globally allocated the 2.3–2.4 GHz band for mobile broadband (MBB) systems at the World Radiocommunication Conference 2007 (WRC-07) [14]. However, the frequency band is currently used by different incumbents in European Conference of Postal and Telecommunications Administrations (CEPT) countries [15]. The main users are PMSE applications, such as wireless camera links [16]. They are typically used to transmit video and audio wirelessly from a camera to an outside broadcasting (OB) van, and the typical users thus are the broadcasting companies.

The spectrum occupancy of the 2.3 GHz band in a single location in Finland was studied using several weeks of spectrum measurement data from Turku spectrum observatory in [17, 18]. The results showed that spectrum occupancy was very low and sporadic, and the detected busy periods were only 3–9 seconds long. The wireless camera transmissions typically occupy a bandwidth of 20 MHz, meaning a 20% occupancy per transmission over the whole 100 MHz frequency band. The instantaneous channel occupancy values were between 0 and 30%, but when the occupancy was filtered with a 5-minute moving average filter, the occupancy was between 0 and 5%. The filtered values confirm that the periods when the spectrum is occupied are very short in time. In addition to the signals interpreted as wireless cameras, only a small number of higher power peaks, probably from narrowband amateur radio services, was detected. The wireless camera transmissions are very low power and difficult to detect, and the studies conducted with a professional level wireless camera in [18] demonstrate that the spectrum observatories are able to detect the wireless cameras only from distances smaller than 250 m. Thus, single-location spectrum occupancy measurements cannot be used to draw strong conclusions on the spectrum occupancy trends over large geographical areas.

One reason why allocating the 2.3 GHz band for MBB in Europe is important is that the frequency band is already in MBB use in other regions. Thus, the transmitter hardware already exists and can be easily implemented in mobile receivers for European market. An economic analysis [19] also indicates that the impact of making 2.3 GHz band available for MBB in Europe could be worth 6.5–22 billion euros. However, the national administrations are unwilling to move the current incumbents to other frequency bands. Such an operation would result in expenses to the incumbents who would need to update their equipment, and in addition, there is a lack of suitable unallocated frequency bands. As the utilization of the 2.3 GHz frequency band appears to be very low, an optimal solution would be to let the current incumbents stay in the frequency band and to allow the MBB operation by exploiting the vacant spectrum resources. Again, the protection of the current incumbents is essential. LSA is needed in the 2.3 GHz band to provide exclusive shared spectrum access to the MBB and to protect the current incumbents.

Working Group Frequency Management (WG FM) established Frequency Management 53 (FM53)—Reconfigurable Radio Systems (RRS) and LSA project team in September 2012. The aim of FM53 was to provide generic guidelines to CEPT administrations for the implementation of the LSA. The European Commission (EC) requested an opinion from RSPG on regulatory and economic aspects of LSA in November 2012 [20], and their final opinion from November 2013 [21] defined that LSA is “a regulatory approach aiming to facilitate the introduction of radiocommunication systems operated by a limited number of licensees under an individual licensing regime in a frequency band already assigned or expected to be assigned to one or more incumbent users. Under the LSA approach, the additional users are authorized to use the spectrum (or part of the spectrum) in accordance with sharing rules included in their rights of the use of spectrum, thereby allowing all the authorized users, including incumbents, to provide a certain QoS.”

Thus, LSA gives the MNOs a predictable QoS through individual licensing and exclusive shared access to the spectrum resources. The MNO accessing shared spectrum through

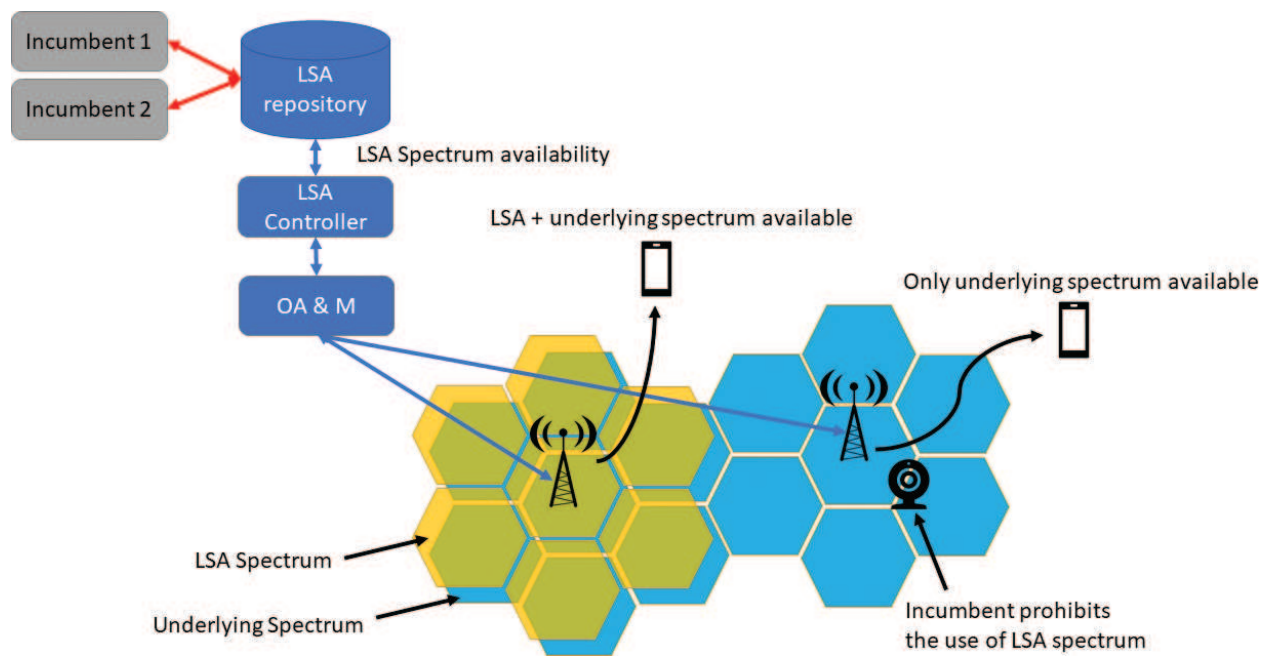

Figure 1. LSA architecture (Adapted from [22]).

temporary leasing is called LSA licensee. The functionalities of LSA are enabled mainly by two additional units on top of the existing mobile networks: the LSA Repository and the LSA Controller. The LSA Repository is a database containing information on incumbent spectrum utilization, while the task of the LSA Controller is to guarantee protection and interference-free operation for both types of users by using the data from the LSA Repository. The LSA Repository can be managed by the National Regulatory Authorities, the incumbents, or a trusted third party.

The LSA Repository contains information on the spectrum availability for LSA licensees and spectrum sharing rules. This information is communicated to the LSA Controller through a secure and reliable communication path. Based on the information from the LSA Repository, the LSA Controller controls the spectrum use of LSA licensee(s). There may be several LSA Repositories from which the LSA Controller gets the information on spectrum availability and also several LSA licensees' networks.

Figure 1 illustrates the LSA architecture. Several incumbents provide information on their spectrum utilization to the LSA Repository, which communicates it to the LSA Controller. The LSA Controller provides this information to the MNO operations, administration, and maintenance (OAM), which instructs that the relevant base stations of the MBB network can use the spectrum resources which are not used by the incumbents in the band. These newly available spectrum resources are taken into use to provide additional capacity through carrier aggregation (CA). The underlying spectrum in other frequency bands (blue cells in the figure) is exclusively licensed for MBB transmissions, while the orange cells can provide additional capacity using the LSA spectrum resources in the 2.3 GHz band. On the right side of the figure, the incumbent operation prevents the use of LSA spectrum, and only the underlying MBB spectrum resources can be used. This is illustrated through the absence of orange LSA cells.

LSA Spectrum Resource Availability Information (LSRAI) contains the information on the LSA spectrum resource that may be used by the LSA licensee. LSRAI is generated in the LSA Repository and sent to the LSA Controller over the LSA₁ interface using LSA₁ protocol messages as defined in the ETSI technical specification [23]. The LSA Information Exchange Function to maintain the LSRAI synchronization between LSA Controllers and LSA Repositories and the LSA₁ protocol are described in detail in [23].

As defined in [23], LSRAI has the following characteristics:

- It contains one or more zones. A zone is an information object which describes a set of operational conditions or restrictions to be applied by the LSA licensee.
- A zone has a zone type associated to it (e.g., restriction, protection, exclusion).
- A zone contains space, frequency, radio, and time parameters:
 - Space parameters describing the geographical area to which the restriction applies.
 - Frequency parameters describing the frequency range to which the restriction applies.
 - Time parameters describing when the restriction applies.
 - Radio parameters describing the RF restrictions to be applied within the space/frequency/time combination defined by the above parameters
- A zone has a zone ID and a zone configuration index associated to it.

3. The status of LSA and SAS

This section considers the feasibility, current status, and evolution of LSA and briefly compares it to the US concept for licensed shared spectrum access; Spectrum Access System (SAS). The work on LSA has been very active in regulation and standardization: CEPT Reports [24–26], ECC harmonized conditions for the use of the 2.3 GHz band in [15, 27–29], and European Telecommunications Standards Institute (ETSI) standardization in [22, 23, 30, 31] provide all the measures needed for a National Regulatory Authorities in a CEPT country to create an implementation of LSA. A regulatory evaluation in [32] concluded that LSA implementations are feasible as they provide a simple spectrum sharing approach providing a high degree of certainty for both the incumbent and the LSA licensee with low impact to the systems and the concept has already been tested and approved. The use of LSA is a national matter, which does not require modifications to the ITU-R Radio Regulations (RR) but needs to comply with the current regulations.

A study on the feasibility of LSA from business perspective [33] concluded that LSA implementations could be profitable for MNOs in Finland if they have a reasonably good customer base and well-defined network launch and management. Most importantly, the MNO has to carefully investigate the techno-economics to see if there is a customer base large enough to justify the investments in new spectrum and network resources. A Finnish LSA

trial environment is operated in Ylivieska [34, 35], but no commercial deployments of LSA in 2.3 GHz band are available yet. A service pilot with LSA radio licenses to commercial end users operating with incumbent wireless cameras in the 2.3 GHz band was announced in the Netherlands in May 2016 [36], and more pilots are expected in the near future. The LTE MNOs are expected to make fairly static multiyear spectrum sharing contracts with the incumbents to justify investments in building mobile network infrastructure for LSA operation [37]. LSA could also provide mechanisms to mitigate intra-MNO-system interference [37].

A concept called SAS is in development in the USA. It is very similar to LSA, as both of them include incumbent users and licensed shared users who have exclusive shared access to the spectrum. The Licensed Shared Access in SAS is known as Priority Access License (PAL). LSA excludes opportunistic access where no protection from incumbents is provided, but SAS adds an additional third tier for unlicensed opportunistic spectrum access with General Authorized Access (GAA), as shown in **Figure 2**. PAL users are protected from interference from GAA tier, but not from the incumbents.

The SAS design ensures protection also for the incumbents who cannot provide a priori information to a central database. This is a major difference to LSA, where this information has to be communicated to a central database (LSA Repository) in order to protect the incumbents. The incumbents operating in the Citizens Broadband Radio Service (CBRS) band include military services whose information is too sensitive to be stored in a database. Instead, SAS includes Environmental Sensing Capability (ESC) component which uses spectrum sensing to provide the needed data for spectrum access decisions. As [38] states, spectrum sensing is not a trivial matter, especially with the strict requirements in SAS. ESC will not be used in the first phase of SAS deployment, which restricts the SAS operation in the zones with military incumbents near coastal areas until a suitable ESC technology is available. ESC technologies have

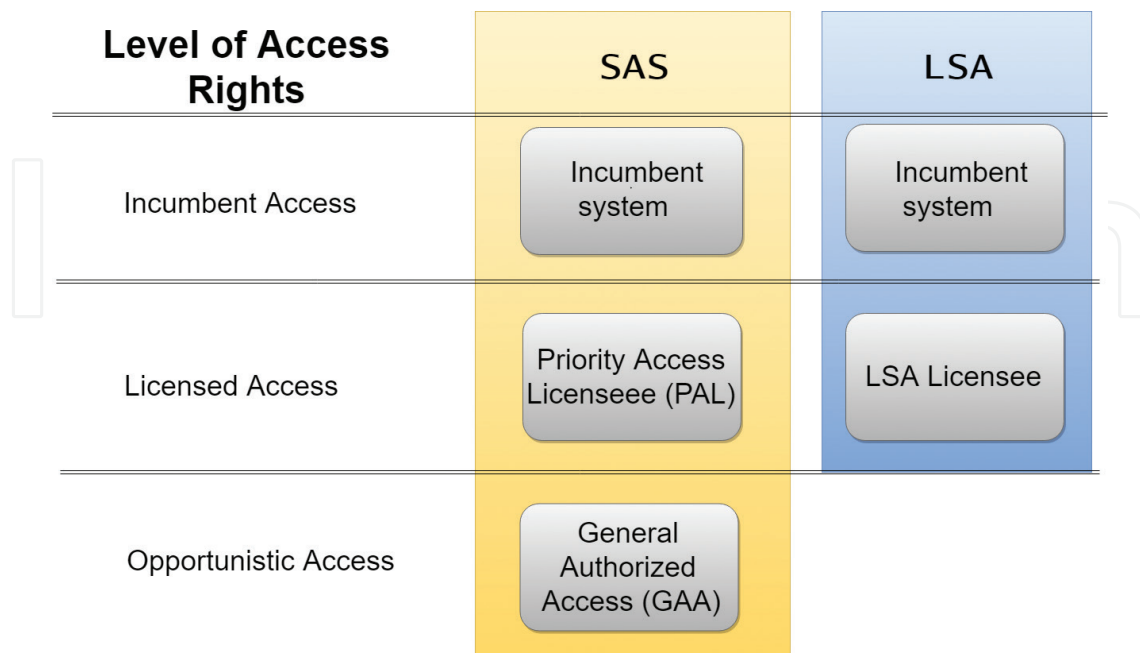

Figure 2. Overview of the level of access rights in different tiers of SAS and LSA sharing models.

already been developed and demonstrated in SAS trials [39]. Unlike LSA, SAS standardization is still in progress, but the industrial interest in CBRS Alliance [40] is strong and advances are expected in the near future. The first commercial SAS deployments are expected during 2018 [41] in 3.55–3.7 GHz CBRS [42] band in the USA. **Table 1** gives a brief comparison of the key features of the LSA and SAS concepts. More detailed considerations and comparisons from both technical and business perspectives are given in [43, 44].

LSA and SAS are currently defined for use only in the mentioned frequency bands with their specific incumbents, but the basic operational principles are straightforward to adopt to other sub-6 GHz frequency bands, where spectrum sharing is more relevant. Spectrum sharing is less relevant in higher frequency ranges, such as mmWaves, where wireless communication is not so much limited by interference, but the higher path losses. The ETSI LSA standardization was done partly in liaison with the 3rd Generation Partnership Project (3GPP) [45], which has studied how LSA could provide a global solution for a 3GPP MNO in [46]. LSA has also been recognized as one of the future technology trends for IMT in the ITU-R Working Party 5D on IMT systems [47].

5G and its new use cases require a more dynamic approach to access shared spectrum resources than ETSI LSA for 2.3–2.4 GHz band can provide. Spectrum sensing techniques are needed as the more dynamic access to spectrum cannot be achieved by using static a priori information. The dominant problems in spectrum sensing are the removal of shadowing and multipath fading. Methods to overcome these problems through cooperative mobile measurements to create interference maps are discussed in [48], but the current technologies related to spectrum sensing are still not able to guarantee protection from harmful interference [43].

	LSA	SAS
Tiers	Two tiers with individual access	3-tier system; two tiers with individual access and a third license-exempt tier
Database	Centralized geo-location database based on static a priori information on the incumbents	Centralized geolocation database with information based on spectrum sensing technologies
Spectral efficiency	Less efficient use of spectrum	More efficient use of spectrum
Use of spectrum	Current version is a static framework for long-term spectrum leasing in 2.3 GHz band. Future LSA evolution will include spectrum sensing to provide more dynamic use of spectrum	GAA tier enables very flexible and dynamic short-term use of spectrum with a very low entry barrier, but the GAA spectrum access and quality are less certain than with the exclusive LSA licenses
Software and hardware	Minimal additions to the existing 3GPP network ecosystem.	Requires new near real-time sensing capabilities and big data and spectrum analytics
Complexity	Less complex	Very complex due to the spectrum sensing needed for the GAA tier
Adaptability	Initially focused on Europe but easily adaptable to other regions	Initially specific to US federal use, additional adaptability is needed for other regions

Table 1. Brief comparison of LSA and SAS concepts.

A concept called LSA evolution is currently under development. The use of spectrum sensing is considered to provide more dynamic version of LSA, which is needed for the novel 5G use cases [49, 50]. The original LSA specification assumes that the spectrum is available for the operator always when the incumbent does not use the spectrum. The spectrum is available for the operator within the regulative area, like country borders, excluding the areas where the incumbent uses the spectrum. From spectrum perspective, high QoS is achieved when the incumbent does not use the spectrum.

The interest in private LTE and 5G networks has grown due to the increased number of IMT frequency bands, higher frequency ranges, variety in spectrum assignments for 3GPP technologies, and revolution of wireless industrial communication [51]. The feasibility study [52] addresses these issues and applies learning from the later developed SAS/CBRS system at the same time. The study considers, for example, how to provide temporary spectrum access for local high-quality wireless networks.

The new concepts for LSA evolution include short-term license periods, possibility to allocate spectrum locally, and supporting co-primary sharing, which can guarantee the quality of service from spectrum perspective [49, 53]. Most LTE use is static, when the spectrum assignments are considered. Even if the user equipments (UEs) are mobile, the spectrum use is more determined by the eNodeBs. They traditionally require masts, electricity, backhaul connectivity, and professional installers.

The temporary LTE or 5G spectrum access is most likely to be related to PMSE, Public Protection and Disaster Relief (PPDR), or Test and Development (T&D) licenses. The current mobile networks are wide area networks even if they are built for capacity. Most private LTE and 5G networks are local. PMSE, PPDR, and T&D networks are both temporary and local and thus can benefit most from LSA evolution.

4. LSA evolution system for 5G PMSE use case trial

This section presents a trial of LSA evolution system developed for 5G PMSE use case. The trial focuses on utilizing LSA for sharing spectrum in 2.3–2.4 GHz band between wireless cameras (PMSE) and mobile network operator (MNO) serving users. When the spectrum is required by the incumbents, such as wireless video cameras during a sports event, the transmissions of the mobile network in this area need to be controlled to allow the operation of the wireless cameras in the band. The mobile network base stations on this band can be shut down or their transmission powers and potentially operating frequencies controlled.

The developed LSA evolution system allows to set priorities for different users of the spectrum, and thus it is possible, for example, to give the highest priority to the old/proprietary PMSE systems which cannot communicate bidirectionally with the spectrum manager, which includes the functionalities of LSA Controller and LSA Repository. The LTE/5G-based equipment can be controlled (their transmission frequencies and power levels adjusted) so that no interference is caused toward the old/proprietary PMSE equipment or other LTE/5G-based equipment.

The trial assumes that the broadcasters and other PMSE stakeholders may have a mixture of proprietary and LTE/5G PMSE wireless technology in use in the future. This trial demonstrates how broadcasters can gradually move from proprietary 2.3 GHz wireless camera technology to 2.3 GHz LTE/5G PMSE. Both old and new equipment can be used simultaneously within the trial system. One major advantage of LTE/5G radio-based PMSE is that the spectrum manager can directly control the equipment (e.g., change its operating frequency to avoid interference). Another advantage of having an own PMSE LTE/5G system compared to using commercial LTE/5G networks for the PMSE traffic is that the PMSE stakeholder is able to fully control the use and thus the load of its own PMSE system.

The architecture of the trial setup shown in **Figure 3** consists of PMSE equipment operating occasionally on 2.3 GHz band and MNO LTE network operating on 700 and 2.3 GHz bands. This represents a situation where MNO employs additional capacity on 2.3 GHz band using, for example, supplemental downlink (SDL) concept. Proprietary PMSE equipment represents an OFDM-based proprietary solution for wireless cameras operating on the band. PMSE LTE in **Figure 3** is a rapidly deployable LTE/5G network for PMSE purposes. Commercial base stations and LTE terminals were used in the trial. The proprietary PMSE equipment was emulated in the trial with a DVB-T/DVB-T2 transmission and Samsung S8 phones streaming video served as LTE-based PMSE equipment.

Spectrum manager orchestrates the operation of the different systems on 2.3 GHz shared band. PMSE system information is collected with a web-based reservation system, where the users of the devices can make reservations for their intended use. The reservation system has been piloted in the Netherlands in 2017–2018 [34]. The control of the PMSE devices also takes place through the reservation system so that the user of the devices is informed about the required spectrum use changes and the user has to deploy the configuration changes in their devices.

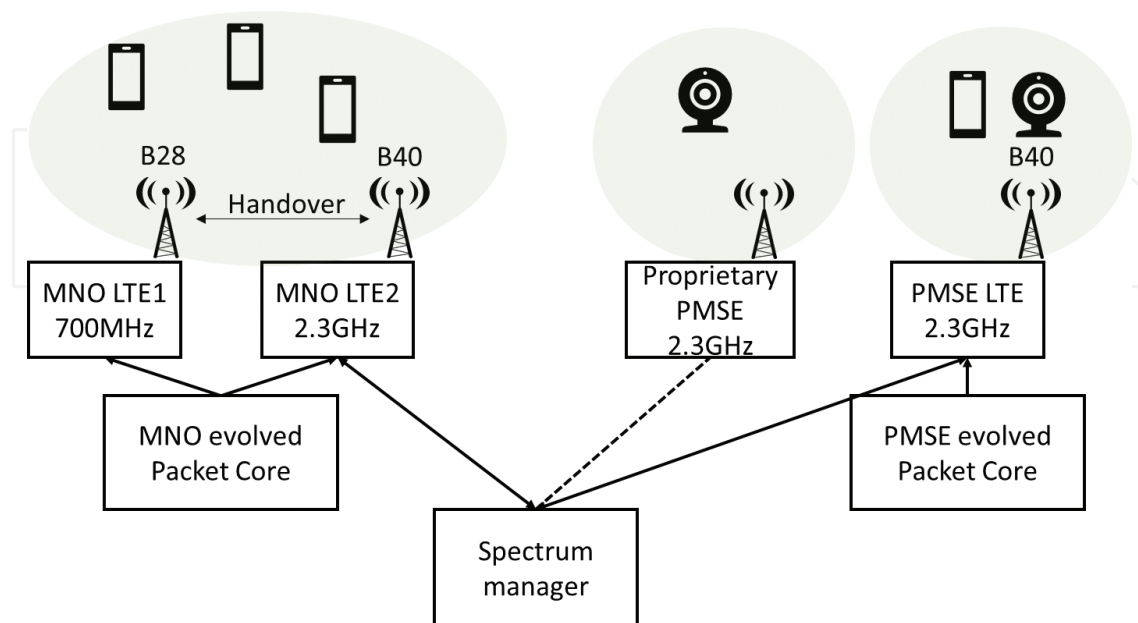

Figure 3. Spectrum demonstration architecture.

Both PMSE LTE and MNO LTE systems have a direct machine-to-machine (M2M) interface between the radio equipment and the spectrum manager. The priority order considered in the trial is as follows, from highest to lowest: PMSE, PMSE LTE, and MNO LTE. When the priority user changes the configuration of the LTE network, a notification about the change is automatically received in the spectrum manager. The spectrum manager processes the changed spectrum situation and evaluates if the lower priority use may cause harmful interference to the higher priority use. If there is a risk of interference, the spectrum manager evaluates which changes would be required to accommodate the higher priority use and to maintain the best possible service level also for the lower priority use.

On the high level, interference mitigation is implemented so that if there are frequency channels available, the lower priority use is transferred to those channels. If there are no other channels available, the power level of the secondary user is reduced or the transmission is denied. In this demonstration, the higher priority user is able to select the frequency channel to be used. An option for this could be that the higher priority user has the right to the spectrum resource in the band, but the specific frequency channel is determined by the spectrum manager.

The main target of the performed trial is to demonstrate the LSA evolution functions developed to the spectrum manager to enable dynamic spectrum sharing between users with different levels of priority. The steps performed in the trial were:

1. MNO LTE1 (700 MHz) and MNO LTE2 (2.3 GHz) serving users (web surfing, video streaming).
2. PMSE LTE (2.3 GHz) turns on as a rapidly deployable network for PMSE, and spectrum is available for both MNO LTE2 and PMSE LTE.
3. PMSE user registers to the spectrum manager registration system, on the frequency currently in use for PMSE LTE.
4. MNO LTE2 limits its transmission power (if necessary) to follow interference limits, and the users remain connected to at least B28 (700 MHz) base station.
5. PMSE LTE changes channel to give space to PMSE.
6. Proprietary PMSE equipment turns on.

Corresponding snapshots of the 2.3 GHz spectrum band are illustrated in **Figure 4**. First, the lowest priority LTE service, such as SDL of MNO LTE2, operates in the band. Then, PMSE using rapidly deployable LTE air interface (PMSE LTE) requests for spectrum. At the same time, there is enough free spectrum for both to operate. Then, the proprietary PMSE equipment requests for spectrum, and the spectrum manager allocates suitable frequencies and power levels for all users. If necessary, MNO LTE2 adjusts the transmission power according to regulated interference limits to allow for the operation of higher priority users. Also, PMSE LTE that is controlled by the spectrum manager via M2M interface switches frequency (e.g., due to the limitations of proprietary PMSE equipment tuning range). Finally, all three networks operate on the shared spectrum without causing interference to each other.

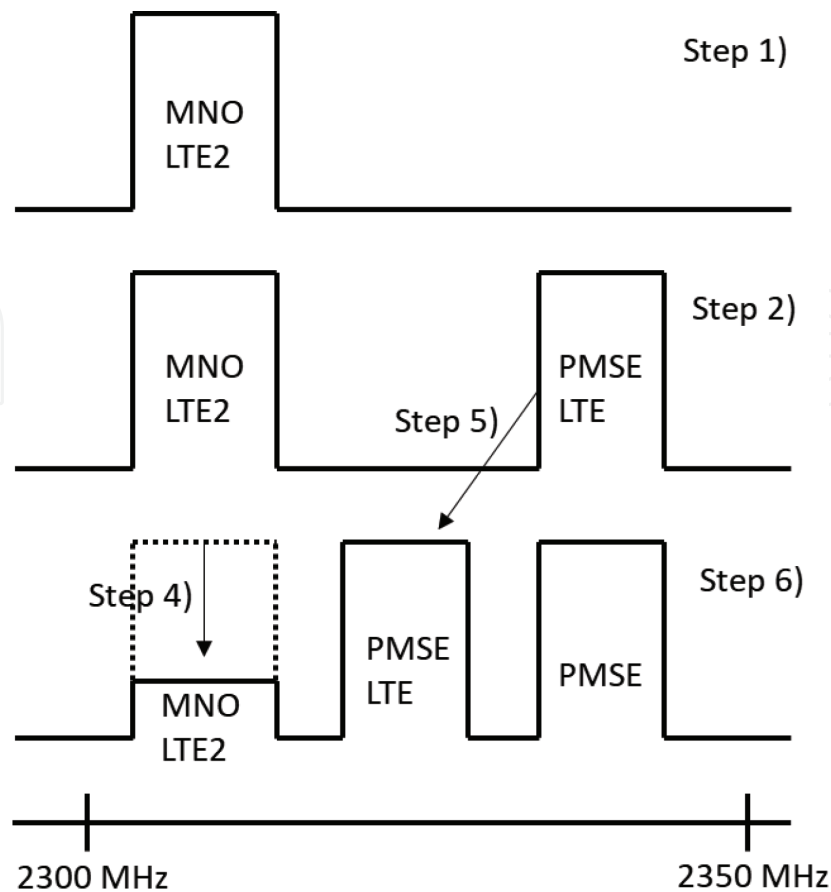

Figure 4. 2.3 GHz spectrum use corresponding to trial steps.

5. LSA evolution in 5G networks

A mobile service of a mobile network operator consists of different mobile network technologies, like GSM, WCDMA, LTE, and 5G. Each of the technologies, especially LTE, has several frequency bands. The bands below 1 GHz are coverage bands, and the bands above 2 GHz are capacity bands. The capacity bands are available only in densely populated areas.

Mobile phones primarily make the decision which technology and which band(s) they use. The availability of the LSA secondary bands cannot be guaranteed at any time or location, but the situation does not differ much from the availability of the capacity bands, when considering the availability of the bands from the mobile device perspective. At an arbitrary location and time, only a part of the deployed technologies and frequency bands are available for a specific mobile device. The generic secondary LSA spectrum use fits best to 5G enhanced Mobile Broadband (eMBB).

The original LSA was developed to allow mobile as a secondary user on the bands, which have other types of priority users. The recent development in ETSI RRS considers LSA for local high-quality networks. The main issue to ensure a guarantee of quality is to have a sharing agreement, where the LSA user is the primary user and is protected from interference.

When the LSA users have a primary status and when they are protected from interference, LSA can be used also for 5G Ultrareliable Low-Latency Communication (URLLC).

When the 5G massive Machine-Type Communication (mMTC) is deployed in coverage networks, LSA may not be the best solution, as the spectrum sharing in the coverage bands is not as beneficial as in the capacity bands. On the other hand, many of the sub-GHz wide-area IoT networks operate on license-exempt bands, which cannot guarantee quality of service either.

The LSA spectrum sharing does not change mobility or handovers in the mobile networks compared to non-LSA mobile networks. The main issue in this respect is the graceful shutdown. The sharing agreement may allow a reasonable delay, i.e., several minutes or more, between the moment information that the primary user requiring interference protection arrives and the moment when the interference protection has to be carried out in the LSA system. In that case, the operations, administration, and maintenance (OAM) of the mobile network can force the mobile to non-LSA bands before the LSA system deploys the interference protection in the LSA band. The graceful shutdown is not a part of the LSA system but rather a feature of the OAM.

6. Conclusion

This chapter has discussed why spectrum sharing is needed and introduced the LSA concept developed to provide a predictable QoS and exclusive access to shared spectrum resources. The first phase of LSA development and standardization created a somewhat static system and rules for the use of LSA in the 2.3–2.4 GHz frequency band. This version of LSA is best suited to facilitate access to sub-6 GHz frequency bands where the existing incumbents are not efficiently using their spectral resources.

However, the novel use cases in 5G require a more dynamic access to the spectrum and novel solutions for coordinated control and spectrum management. Spectrum sensing techniques are needed to provide the more dynamic access to spectrum, as the current version of LSA and its static spectrum allocations are insufficient for this. The spectrum sensing techniques however still need to evolve to be able to guarantee protection from harmful interference.

The development of LSA evolution is underway, and the other new concepts needed for LSA evolution include short-term license periods, possibility to allocate spectrum locally, and support for co-primary sharing, which can guarantee the QoS from spectrum perspective. The chapter also described a demonstration of LSA evolution system with spectrum user prioritization, which was created for 5G PMSE use case.

Acknowledgements

This work is supported by Business Finland under the project Critical Operations over Regular Networks (CORNET). The views expressed in this contribution are those of the authors and do not necessarily represent the projects.

Author details

Juha Kalliovaara¹, Tero Jokela¹, Heikki Kokkinen² and Jarkko Paavola^{1*}

*Address all correspondence to: jarkko.paavola@turkuamk.fi

1 Turku University of Applied Sciences, Turku, Finland

2 Fairspectrum, Espoo, Finland

References

- [1] Cisco. Cisco visual networking index: Global mobile data traffic forecast update, 2016-2021 white paper. Feb 2017
- [2] Ericsson. Ericsson mobility report 2017. Nov 2017
- [3] ITU-R. Report ITU-R M.2290: Future spectrum requirements estimate for terrestrial IMT. Dec 2013
- [4] McHenry MA, Tenhula PA, McCloskey D, Roberson DA, Hood CS. Chicago spectrum occupancy measurements & analysis and a long-term studies proposal. In: Proceedings of the First International Workshop on Technology and Policy for Accessing Spectrum (TAPAS 06). 2006
- [5] Valenta V, Fedra Z, Marsalek R, Baudoin G, Villegas M. Towards cognitive radio networks: Spectrum utilization measurements in suburb environment. In: 2009 IEEE Radio and Wireless Symposium. Jan 2009. pp. 352-355
- [6] Lopez-Benitez M, Umbert A, Casadevall F. Evaluation of spectrum occupancy in Spain for cognitive radio applications. In: Vehicular Technology Conference; 2009. VTC Spring 2009. IEEE 69th; Apr 2009. pp. 1-5
- [7] European Commission. COM/2012/478: Promoting the shared use of radio spectrum resources in the internal market. Sept 2012
- [8] President's Council of Advisors on Science and Technology. Realizing the full potential of government-held spectrum to spur economic growth. Jul 2012
- [9] Zhao Q, Sadler BM. A survey of dynamic spectrum access. IEEE Signal Processing Magazine. May 2007;24(3):79-89. DOI: 10.1109/MSP.2007.361604
- [10] Ponomarenko-Timofeev A, Pyattaev A, Andreev S, Koucheryavy Y, Mueck M, Karls I. Highly dynamic spectrum management within licensed shared access regulatory framework. IEEE Communications Magazine. Mar 2016;54(3):100-109. DOI: 10.1109/MCOM.2016.7432155
- [11] COHERENT. Deliverable D4.1: Report on enhanced LSA, intra-operator spectrum-sharing and micro-area spectrum sharing, Coordinated control and spectrum management

- for 5G heterogeneous radio access networks [Online]. 2015. Available from: http://www.ict-coherent.eu/coherent/wp-content/uploads/2015/10/COHERENT_D4_1_v1.pdf
- [12] RSPG. RSPG11-392: Report on Collective Use of Spectrum (CUS) and other spectrum sharing approaches. Nov 2011
- [13] CEPT/ECC. FM(12)084 Annex 47: Report on ASA concept. 2012
- [14] ITU. Final acts WRC-07: World Radiocommunication Conference (Geneva 2007). 2007
- [15] ECC. ECC decision (14)02: Harmonised technical and regulatory conditions for the use of the band 2300-2400 MHz for Mobile/Fixed Communications Networks (MFCN). Jun 2014
- [16] ECC. ECC document FM(12)017rev1: Results of the WG FM QUESTIONNAIRE to CEPT ADMINISTRATIONS on the current and future usage of frequency band 2300-2400 MHz. Apr 2012
- [17] Höyhty M, Matinmikko M, Chen X, Hallio J, Auranen J, Ekman R, Röning J, Engelberg J, Kalliovaara J, Taher T, Riaz A, Roberson D. Measurements and analysis of spectrum occupancy in the 2.3-2.4 GHz band in Finland and Chicago. In: 9th International Conference on Cognitive Radio Oriented Wireless Networks and Communications (CROWNCOM), Jun 2014. 2014. pp. 95-101
- [18] Höyhty M, Matinmikko M, Chen X, Hallio J, Auranen J, Ekman R, Röning J, Engelberg J, Kalliovaara J, Taher T, Riaz A, Roberson D. Spectrum occupancy measurements in the 2.3-2.4 GHz band: Guidelines for licensed shared access in Finland. EAI Endorsed Transactions on Cognitive Communications. May 2015;1(2),e2:1-11. DOI: 10.4108/cogcom.1.2.e2
- [19] Lavender T, Marks P, Wongsaroj S. The economic benefits of LSA in 2.3 GHz in Europe. Dec 2013
- [20] RSPG. RSPG12-424 final: RSPG request for opinion on licensed shared access (LSA). Nov 2012
- [21] RSPG. RSPG13-538: RSPG opinion on licensed shared access. Nov 2013
- [22] ETSI. ETSI TR 103 113 v1.1.1.: Mobile broadband services in the 2300-2400 MHz frequency band under Licensed Shared Access regime. Jul 2013
- [23] ETSI. ETSI TS 103 379 V1.1.1: Reconfigurable radio systems (RRS); Information elements and protocols for the interface between LSA controller (LC) and LSA repository (LR) for operation of licensed shared access (LSA) in the 2300 MHz–2400 MHz band. Jan 2017
- [24] CEPT. CEPT report 55: Report A from CEPT to the European commission in response to the mandate on harmonised technical conditions for the 2300-2400 MHz (2.3 GHz) frequency band in the EU for the provision of wireless broadband electronic communications services: Technical conditions for wireless broadband usage of the 2300-2400 MHz frequency band. Nov 2014

- [25] CEPT. CEPT report 56: Report B1 from CEPT to the European commission in response to the mandate on harmonised technical conditions for the 2300-2400 MHz (2.3 GHz) frequency band in the EU for the provision of wireless broadband electronic communications services: Technological and regulatory options facilitating sharing between wireless broadband applications (WBB) and the relevant incumbent service/application in the 2.3 GHz band. Mar 2015
- [26] CEPT. CEPT report 58: Report B2 from CEPT to the European commission in response to the mandate on harmonised technical conditions for the 2300-2400 MHz (2.3 GHz) frequency band in the EU for the provision of wireless broadband electronic communications services: Technical sharing solutions for the shared use of the 2300-2400 MHz band for WBB and PMSE. Jul 2015
- [27] ECC. ECC report 205: Licensed shared access (LSA). Feb 2014
- [28] ECC. ECC recommendation (14)04: Cross-border coordination for mobile/fixed communications networks (MFCN) and between MFCN and other systems in the frequency band 2300-2400 MHz. May 2014
- [29] ECC. ECC recommendation(15)04: Guidance for the implementation of a sharing framework between MFCN and PMSE within 2300-2400 MHz. Jul 2015
- [30] ETSI ETSI TS 103 154 V1.1.1: Reconfigurable radio systems (RRS); System requirements for operation of mobile broadband systems in the 2300 MHz–2400 MHz band under licensed shared access (LSA). Oct 2014
- [31] ETSI. ETSI TS 103 235 V1.1.1: Reconfigurable radio systems (RRS); System architecture and high level procedures for operation of licensed shared access (LSA) in the 2300 MHz–2400 MHz band. Oct 2015
- [32] Mustonen M, Matinmikko M, Roberson D, Yrjölä S. Evaluation of recent spectrum sharing models from the regulatory point of view. In: 1st International Conference on 5G for Ubiquitous Connectivity (5GU), Nov 2014. 2014. pp. 11-16
- [33] Luttinen E, Matinmikko M, Ahokangas P, Katz M, Yrjölä S. Feasibility assessment of licensed shared access (LSA) concept—Case of a Finnish mobile network operator (MNO). In: 1st International Conference on 5G for Ubiquitous Connectivity (5GU), Nov 2014. 2014. pp. 252-257
- [34] Palola M, Matinmikko M, Prokkola J, Mustonen M, Heikkilä M, Kippola T, Yrjölä S, Hartikainen V, Tudose L, Kivinen A, Paavola J, Heiska K. Live field trial of licensed shared access (LSA) concept using LTE network in 2.3 GHz band. In: IEEE International Symposium on Dynamic Spectrum Access Networks (DYSPAN), Apr 2014. 2014. pp. 38-47
- [35] Matinmikko M, Palola M, Saarnisaari H, Heikkilä M, Prokkola J, Kippola T, Hänninen T, Jokinen M, Yrjölä S. Cognitive radio trial environment: First live authorized shared

- access-based spectrum-sharing demonstration. *Vehicular Technology Magazine, IEEE*. Sept 2013;8(3):30-37. DOI: 10.1109/MVT.2013.2269033
- [36] Radiocommunications Agency of the Netherlands. Licensed shared access pilot in the Netherlands [Online]. 2016. Available from: https://cept.org/Documents/wg-fm/33535/5-3_pmse-lsa-in-the-band-2300-2400-mhz-nl [Accessed: 20-04-2018]
- [37] Badic B, Drewes C, Karls I, Mueck M. *Rolling out 5G: Use Cases, Applications, and Technology Solutions*. New York, US: Apress; 2016
- [38] Vartiainen J, Höyhty M, Vuothoniemi R, Ramani VL. The future of spectrum sensing. In: 2016 Eighth International Conference on Ubiquitous and Future Networks (ICUFN). Jul 2016. pp. 247-252
- [39] Aho P, Palola M, Kippola T, Heikkilä M, Mäkeläinen M, Hänninen T, Tudose L, Hartikainen V, Yrjölä S, Kivinen A, Paavola J. Field trial of citizens broadband radio service (CBRS)/spectrum access system (SAS). In: *Wireless Innovation Forum European Conference on Communications Technology and Software Defined Radio (WinnComm-Europe 2016)*; Paris, France. Oct 2016
- [40] CBRS Alliance [Online]. Available from: <http://www.cbrsalliance.org/> [Accessed: 25-04-2018]
- [41] CBRS WinnForum Standards. CBRS Status Summary [Online]. Available from: <https://www.cbrs.wirelessinnovation.org/cbrr-status-summary> [Accessed: 25-04-2018]
- [42] FCC. 3.5 GHz Band/Citizens Broadband Radio Service [Online]. Available from: <https://www.fcc.gov/rulemaking/12-354> [Accessed: 25-04-2018]
- [43] Massaro M. Next generation of radio spectrum management: Licensed shared access for 5G. *Telecommunications Policy*. Jun 2017;41(5-6):422-433. DOI: 10.1016/j.telpol.2017.04.003
- [44] Yrjölä S, Matinmikko M, Mustonen M, Ahokangas P. Spectrum sharing transforms mobile broadband networks towards markets—Analysis of sharing economy antecedents for recent spectrum sharing concepts. *International Journal on Advances in Intelligent Systems*. Dec 2017;10(3&4):410-422
- [45] Mustonen M, Matinmikko M, Palola M, Rautio T, Yrjölä S. Analysis of requirements from standardization for licensed shared access (LSA) system implementation. In: *IEEE International Symposium on Dynamic Spectrum Access Networks (DySPAN)*, Sept 2015. 2015. pp. 71-81
- [46] 3GPP. 3GPP TR 32.855 V14.0.0: Study on OAM support for licensed shared access (LSA); (Release 14). Oct 2015
- [47] ITU-R. Report ITU-R M.2320-0: Future technology trends of terrestrial IMT systems. Nov 2014

- [48] Höyhty M, Mammela A, Eskola M, Matinmikko M, Kalliovaara J, Ojaniemi J, Suutala J, Ekman R, Bacchus R, Roberson D. Spectrum occupancy measurements: A survey and use of interference maps. *IEEE Communications Surveys & Tutorials*;18(4):2386-2414, Fourthquarter 2016. DOI: 10.1109/COMST.2016.2559525
- [49] Yrjölä S, Kokkinen H. Licensed shared access evolution enables early access to 5G spectrum and novel use cases. *EAI Endorsed Transactions on Wireless Spectrum*. Dec 2017;3(10),e1:1-11. DOI: 10.4108/eai.12-12-2017.153463
- [50] Frascolla V, et al. Dynamic licensed shared access—A new architecture and spectrum allocation techniques. In: 2016 IEEE 84th Vehicular Technology Conference (VTC-Fall); Montreal, QC. 2016. pp. 1-5. DOI: 10.1109/VTCFall.2016.7880971
- [51] Kokkinen H, Yrjölä S, Engelberg J, Kokkinen T. Pricing private LTE and 5G radio licenses on 3.5 GHz. *Cognitive Radio Oriented Wireless Networks and Communications (CROWNCOM)*. 2018
- [52] ETSI. ETSI TR 103 588 V1.1.1: Reconfigurable radio systems (RRS); Feasibility study on temporary spectrum access for local high-quality wireless networks. Feb 2018
- [53] Guirao MDP, Wilzeck A, Schmidt A, Septinus K, Thein C. Locally and temporary shared spectrum as opportunity for vertical sectors in 5G. *IEEE Network*. Nov 2017;31(6):24-31. DOI: 10.1109/MNET.2017.1700079