

Received June 30, 2020, accepted July 17, 2020, date of publication July 23, 2020, date of current version August 5, 2020.

Digital Object Identifier 10.1109/ACCESS.2020.3011550

Driver Lane Change Intention Recognition of Intelligent Vehicle Based on Long Short-Term Memory Network

LIANG TANG¹, HENGYANG WANG², (Student Member, IEEE), WENHAO ZHANG³, ZHONGYI MEI¹, AND LIANG LI³, (Senior Member, IEEE)

¹School of Technology, Beijing Forestry University, Beijing 100083, China

²School of Electrical Engineering, Beijing Jiaotong University, Beijing 100044, China

³State Key Laboratory of Automotive Safety and Energy, Tsinghua University, Beijing 100084, China

Corresponding author: Liang Tang (happyliang@bjfu.edu.cn)

This work was supported in part by the National Natural Science Foundation of China under Grant 51975057.

ABSTRACT Driving intention prediction is one of the key technologies for the development of advanced assisted driving systems (ADAS), which could greatly reduce traffic accidents caused by lane change and ensure driving safety. In this paper, an advanced predictive method based on Multi-LSTM (Long Short-Term Memory) is proposed to predict lane change intention effectively. First, the training data set and test set based on real road information data set NGSIM (Next Generation SIMulation) are built considering ego vehicle driving state and the influence of surrounding vehicles. Second, the Multi-LSTM-based prediction controller is constructed to learn vehicle behavior characteristics and time series relation of various states in the process of lane change. Then, the influences of prediction model structure change and data structure change on test results are verified. Finally, the verification tests based on HIL (Hardware-in-the-Loop) simulation are constructed. The results show that the proposed prediction model can accurately predict the vehicle lane change intention in highway scenarios and the maximum prediction accuracy can reach 83.75%, which is higher than that of common method SVM (Support Vector Machine).

INDEX TERMS Intelligent vehicle, lane change, driving intention prediction, advanced assisted driving systems, multi-LSTM.

I. INTRODUCTION

With the development of advanced sensor technology and artificial intelligence method, ADAS have been studied a lot in recent decades, which can effectively ensure driving safety, avoid traffic accidents, reduce energy consumption and improve ride comfort [1]–[4]. For example, collision avoidance system (CA) [5], [6], adaptive cruise control (ACC) [7]–[9], active front steering (AFS) [10], [11], autonomous emergency brake system (AEB) [12], [13] and lane keeping assistance (LKA) [14], [15]. Driving intention prediction is one of the core technologies of the next generation of ADAS products, which have the ability to infer the future intentions of drivers to predict the likelihood of potential collisions and take measures in advance to avoid accidents [16]. Among all kinds of driving maneuvers, the change of

traffic way, including lane changing, lane merging and lane turning, involved a relatively high percentage (27%) [17]. Lane change, as a common driving behaviour, is one of the main causes of vehicle collision and how to accurately predict lane change intention has drawn a lot of interest of many foreign universities, research institutes and vehicle factories.

Lane change refers to the driver's driving behavior of driving away from the current lane and merging into the target lane according to the driving demand after analyzing the traffic information of surrounding vehicles. In general, lane change intention recognition methods can be divided into two types: driver behavior data based on prediction and vehicle trajectory data-based prediction. At the driver level, we mainly test the facial expression information and body movement of the driver through the cameras installed in front of the driver and then analyze the characteristics of drivers before lane change process, which is suitable for the prediction of ego vehicle intention. Meanwhile, the lane change

The associate editor coordinating the review of this manuscript and approving it for publication was Dian Tjondronegoro¹.

process is a continuous process with temporal characteristics, which means the running state of vehicle has the characteristics of continuity. Thus, we can analyze the driving trajectory data of vehicle to predict lane change intention.

A personalized LCPM based on deep learning method, was constructed to predict the lane change intention of the driver through analyzing the ego vehicle dynamics data and driver physiological data [18]. A novel driver monitoring algorithm was proposed to monitor the driver's facial expression and then decided which operation would be performed, which could improve the performance of ADAS [19]. However, in order to predict the lane change intention of other vehicles, the driver physiological data is not available. Before the large-scale application of artificial intelligence technology, the rule-based lane change intention recognition method was proposed in [20], which determines the vehicle motion maneuver by calculating lateral velocity cue and lateral position cue. Through the rule-based method has advantages of low computational complexity and flexibility, it has no ability to predict lane change intention.

Meanwhile, A driver intention recognition system was proposed in [21]. Continuous Hidden Markov Model is applied to recognize drivers' lane change maneuver by collecting time information about car velocity, car acceleration, and steering angle. Reference [22] studied the lane change prediction problem by using the support vector machine composed of feature variance and Simulation results verified the effectiveness of the method. Meanwhile, [23] constructed Relevance Vector Machine controller, a Bayesian extension of support vector machine, to predict the lane change intention. As we all know, the lane change process is sequential process and lane changing operation is continuous. However, the mentioned methods above don't take into account this characteristic. With the achievement of LSTM in speech recognition and machine translation, LSTM becomes the main method to solve the timing problem. For example, [24] proposed a DBN-based LCD (Lane-changing decisions) model and LSTM-based LCI (Lane-changing implementation) model to predict LC process and testing results indicated that it had a good performance on accurately predicting lane change intention, and a meaningful conclusion is conducted that relative positions of the surrounding vehicles have an greater impact on driver decision making than relative speed. Moreover, a novel car-following method with lane change intention estimation was presented in [25], which can estimate vehicle's behavior by a threshold-based classification method and optimize the car-following acceleration through MPC method, meanwhile, the accuracy of lane change prediction based on this method is compared with that of SVM in this paper.

In this paper, an advanced lane change intention prediction method based on Multi-LSTM is presented. The method uses real traffic information data set (NGSIM) to train the prediction model, which has the ability to predict left turn intention, right turn intention and going-straight intention. The first LSTM network is used to extract the lane changing feature,

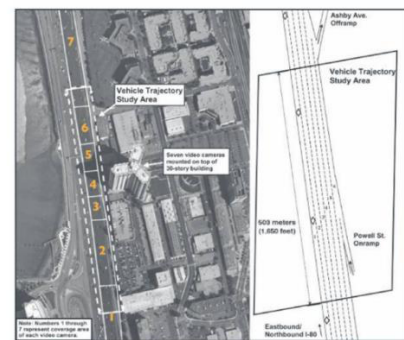

(a)

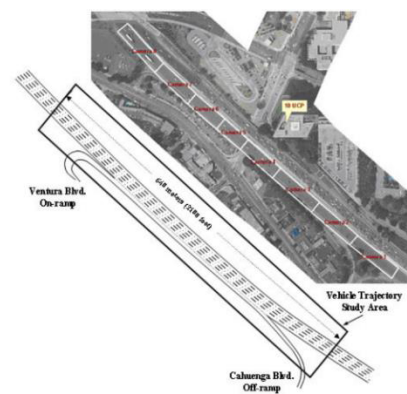

(b)

FIGURE 1. Road segments of NGSIM. (a) Interstate 80 (b) U.S. Highway 101.

and the second network has the ability to judge the intention. The remainder of this paper is organized as follows: How to make training data set and test data set accurately through NGSIM is presented in Section II. Section III describes the construction of prediction model based on LSTM. The influence of prediction model structure change and data structure change on test results is proposed in Section IV. The performance of proposed prediction method is tested by simulation experiments in Section V. Then, conclusions are provided in Section VI.

II. DATA SET CONSTRUCTION

A. NGSIM INTRODUCTION

In this paper, the real traffic trajectory data of NGSIM project conducted by the Federal Highway Administration is used to construct the training data set and test data set for lane change intention prediction, which contains traffic data on the segment of southbound U.S. Highway 101 (Hollywood Freeway) in Los Angeles, CA, and the segment of Interstate 80 in San Francisco, CA. U.S [26], as shown in Figure 1. The recording time on each segment is 45 minutes (Interstate 80: 4:00 P.M. to 4:15 P.M. and 5:00 P.M. to 5:30 P.M. / U.S. Highway 101: 7:50 A.M. to 8:35 A.M.), which can be divided into two processes: the first 15mins for building up congestion and the last 30mins for traffic congestion [27].

NGSIM data includes Vehicle ID, Position X, Position Y, Vehicle Speed and Lane ID etc. Because the state data is measured by the camera installed in the roadside, the measured values of vehicle speed and location exhibit measurement noise [28]. In order to improve the data quality, symmetrically exponentially weighted moving average filter is used to smooth vehicle trajectories. The smoothing method is presented as follows:

$$\bar{x}_\alpha(t_i) = \frac{\sum_{k=i-D}^{I+D} x_\alpha(t_k) e^{-\frac{|i-k|}{\Delta}}}{\sum_{k=i-D}^{I+D} e^{-\frac{|i-k|}{\Delta}}} \quad (1)$$

where, $\bar{x}_\alpha(t_i)$ denotes state value after filtering at t_i , D is size of sliding window and Δ is average window of intermediate data.

B. INPUT VARIABLES

Lane change means that the vehicle drives from the current lane to the adjacent lane without collision, which will cause the changes of Lane ID and Lateral Speed. In order to build the training data set and test data set for lane change, we need to select the vehicles with lane change behavior and determine their corresponding lane change starting points, which can be obtained by the rule-based method. First, we traverse the entire NGSIM data set to find the vehicle whose Lane ID has changed and record the time stamp when lane changing. A right turn means an increase of lane ID and a left turn denotes a decrease. If a vehicle has multiple lane changes, each lane change is recorded separately. Then, the starting points of lane change can be determined when the change of lateral velocity is greater than a certain threshold value. The selected data set is crucial for the accuracy of neural network model. If the network model is trained with inaccurate data set, the incorrect features will be learned by the model and then the accuracy of identification will not be guaranteed. Thus, all data must be reviewed manually. The upper figure in Figure 2 shows the rule-based data set making method produces inevitable errors. The starting point of lane change appears in the process of driving on the lane line, which is obviously not consistent with normal driving behaviour. The real process is to change lane before driving on the lane line and the reason for driving on the lane is to wait to ensure the complete safety of the target lane. Thus, the real starting point of lane change is shown in the below figure in Figure 2.

As we all know, drivers decide whether to change lane or not according to real-time traffic information. The traffic situation of current lane and the target lane will directly affect the decision of the driver on lane change. So, nine normal factors are considered as the inputs of prediction model to train the model:

V_{ref_cf} : The speed difference between the ego vehicle and the lead vehicle in the current lane. V_{ref} means the ego vehicle speed and V_{cf} is the lead vehicle speed in the current lane.

$$V_{ref_cf} = V_{ref} - V_{cf} \quad (2)$$

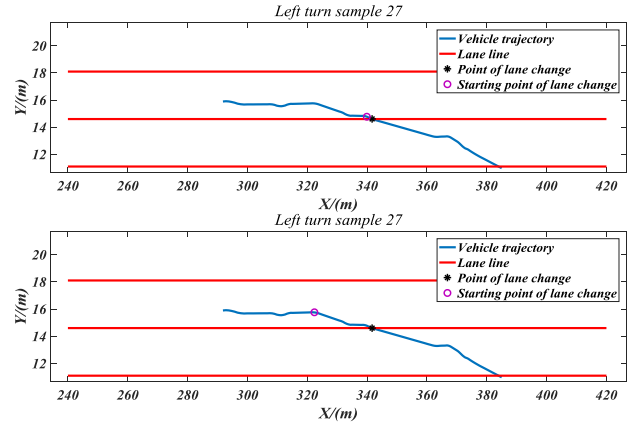

FIGURE 2. Data review process.

D_{ref_cf} : the gap distance between the ego vehicle and the lead vehicle in the current lane. D_{ref} means the absolute position of the ego vehicle and D_{cf} is the absolute position of the lead vehicle in the current lane.

$$D_{ref_cf} = D_{ref} - D_{cf} \quad (3)$$

V_{ref_cr} : The speed difference between the ego vehicle and the lag vehicle in the current lane.

D_{ref_cr} : the gap distance between the ego vehicle and the lag vehicle in the current lane.

V_{ref_tf} : The speed difference between the ego vehicle and the lead vehicle in the target lane.

D_{ref_tf} : the gap distance between the ego vehicle and the lead vehicle in the target lane.

V_{ref_tr} : The speed difference between the ego vehicle and the lag vehicle in the target lane.

D_{ref_tr} : the gap distance between the ego vehicle and the lag vehicle in the target lane.

V_{ref} : the ego vehicle speed.

In order to verify the influence on the intention of lane change of vehicles in the adjacent lane of the target lane, the following four factors are constructed:

V_{ref_tar} : The speed difference between the ego vehicle and the lag vehicle in the adjacent lane of target lane.

D_{ref_tar} : the gap distance between the ego vehicle and the lag vehicle in the adjacent lane of target lane.

V_{ref_taf} : The speed difference between the ego vehicle and the lead vehicle in the adjacent lane of target lane.

D_{ref_taf} : the gap distance between the ego vehicle and the lead vehicle in the adjacent lane of target lane.

III. MODEL

A. REVIEW OF LSTM

At present, the widely used classification method in the field of artificial intelligence is the deep learning model based on CNN (Convolutional Neural Networks), which easily lead to vanishing gradient problem due to gradient update information decaying exponentially. In order to overcome the vanishing gradient problem, LSTM based on gate structure is proposed, which is consisted of three gates, i.e., the input

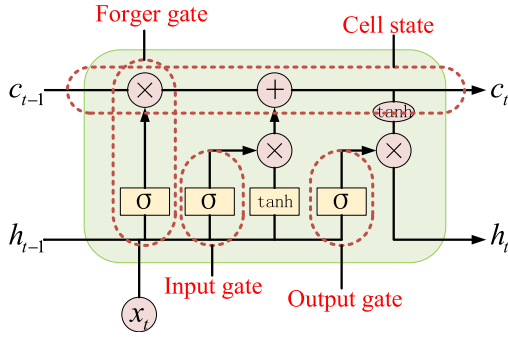

FIGURE 3. The architecture of LSTM.

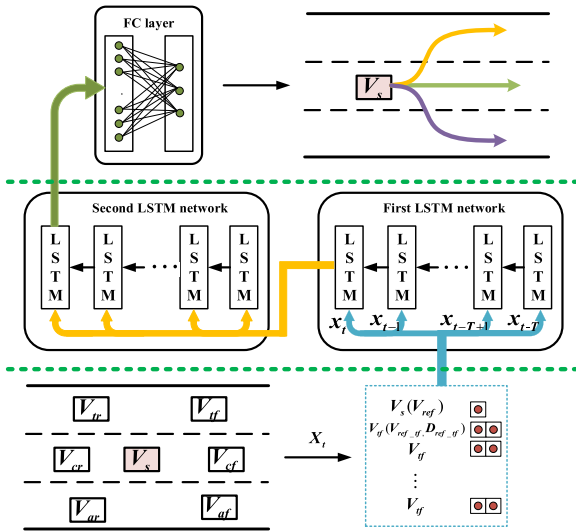

FIGURE 4. The architecture of Multi-LSTM.

gate, the forget gate, and the output gate [29], [30], as shown in Figure 3. The inputs can be divided into the cell state c_{t-1} at $t - 1$ time, the output h_{t-1} and the input x_t at the current time and the outputs are c_t and h_t . The functions of gates can be described as: forget gate determines the influence of the cell state c_{t-1} at the last moment on c_t , the input gate defines the share of the current input x_t reserved to c_t , and the output gate determines the amount of cell unit c_t transferred into the output h_t . The calculation process can be constructed as [31]:

$$f_t = \sigma(W_{xf}x_t + W_{hf}h_{t-1} + b_f) \quad (4)$$

$$i_t = \sigma(W_{xi}x_t + W_{hi}h_{t-1} + b_i) \quad (5)$$

$$o_t = \sigma(W_{xo}x_t + W_{ho}h_{t-1} + b_o) \quad (6)$$

$$c_t = f_t \odot c_{t-1} + i_t \odot \tanh(W_{xc}x_t + W_{hc}h_{t-1} + b_c) \quad (7)$$

$$h_t = o_t \odot \tanh(c_t) \quad (8)$$

where, $\sigma(x)$ means sigmoid function, \odot is element wise product, and f_t, i_t, o_t are gating vectors.

B. MULTI-LSTM MODEL

Inspired by the LSTM encoder-decoder architecture [32]–[34], a Multi-LSTM prediction model is proposed in this paper, as shown in Figure 4. At t time, the sequence $x_{t-i} = [V_{ref_t-i}, V_{ref_tf_t-i}, \dots, D_{ref_taf}]$, $i = 0, 1, \dots, T - 1$

is fed into the first LSTM network to classify lane changing characteristics. T means length of time series and is a variable. [34] has proven that the traffic condition around vehicle is very difficult to analyze since it is influenced by various latent factors and these factors change dynamically in all real-time, e.g., driver's intention and improper operation. Therefore, the first LSTM network is constructed to extract lane changing features as many as possible.

After feature extraction network processing, 726 lane changing features are identified and then transmitted to the intention recognition network. As a representation of a specific traffic phenomenon, lane changing features also have continuity in time sequence. Thus, the intention recognition network is designed as federation of LSTM to capture the temporal relations between successive lane changing features. In order to suppress overfitting, prediction outputs are not directly connected to intention recognition network but transferred from an output layer, which can increase nonlinearity of the whole network.

Note that the outputs of the Multi-LSTM network are the probabilities of left turn, right turn and going-straight and the operation with the maximum probability value will be considered as the prediction intention. The proposed recognition model separates feature extraction from intention prediction, i.e., a specified feature extraction network is designed, which extends the network capacity enough to capture the complex structure of the trajectory data to predict lane change intention more accurately. Compared with traditional LSTM, our proposed Multi-LSTM method can not only take into account the sequential and continuous characteristics of lane changing process, but also extract deeper lane changing features.

IV. INFLUENCE OF NETWORK STRUCTURE AND DATA STRUCTURE

Model network structure and data structure have fundamental impact on effect of lane change intention recognition. The number of hidden layers, one of basic parameters of LSTM network structure, represents the number of nodes used to remember and store the past state, which determines how much information is remembered and how much is forgotten. In terms of the principle of neural network construction, the more hidden layers, the more data features will be mastered, and the higher adaptability of network. However, too many hidden layers will lead to the overfitting phenomenon of neural network, which will result in the failure of classification task. 2 seconds traffic state data set is used to test the impact of different number of hidden layers on recognition accuracy, as shown in Figure 5.

In Figure 5, we can conclude that the recognition accuracy increases from 0.764 with 10 hidden layers to 0.81164 with 400 hidden layers as the network structure becomes more and more complex, which shows more lane change features are found and mastered for more specific understanding of lane change operation. However, over complex network structure will lead to overfitting phenomenon, which means that some

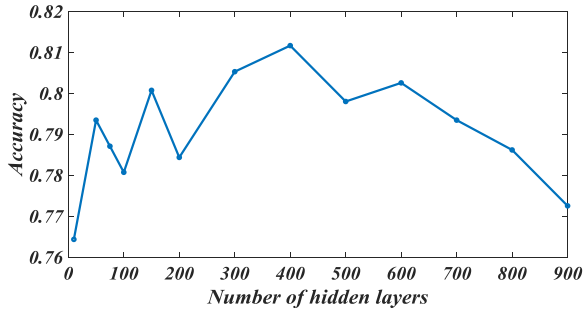

FIGURE 5. Influence of the number of hidden layers.

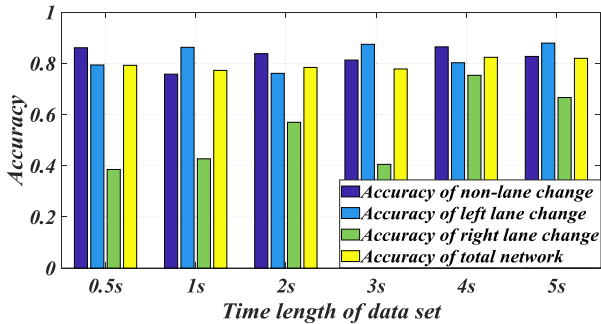

FIGURE 6. Influence of the time length of data set.

characteristics of random motion are wrongly learned and results in the decrease of the robustness of intention recognition. The accuracy of intention judgment is decreasing when the number of hidden layers is greater than 400. In summary, 200-400 hidden layers are appropriate for ensuring the recognition accuracy and the calculation pressure of the network.

The lane change process is time continuous and the time length before lane change is one of important factors in making training data set. On the one hand, data set with small time span cannot guarantee that it covers all the preparation stages before lane change. On the other hand, data set with too large time span will not only increase the pressure of network computing, but also introduce some interference features affecting prediction of lane change intention. Thus, data sets with different time span with 200 hidden layers are trained to verify the effect of data structure on network performance, as shown in Figure 6. Extracted datasets from NGSIM include 1363 samples of left turn change, 280 samples of right turn change and 1687 samples of going-straight. 70% of the data samples are used to train the model, and the remaining 30% are used to test the accuracy of the prediction model. Comparing the left turn change intention recognition and right turn change in Figure 6, we can draw the conclusion that the more data samples are, the higher the accuracy of model recognition is. When the number of data samples is small, e.g., the right turn change, increasing the time span of data appropriately can increase the judgment characteristics and the prediction accuracy. The reason why the accuracy of 5 seconds data set reduces is that the time span is so long that the interference characteristics are also learned.



FIGURE 7. Hardware-in-the-Loop platform.

TABLE 1. The settings of the Multi-LSTM network model.

Item	Value
Hidden layer	400
Epoch	200
Iteration	7400
Iterations per epoch	37
Learning rate	0.001

V. EXPERIMENT VERIFICATION

In order to verify the accuracy of the proposed model, rule-based method and SVM (Support Vector Machine) are introduced to predict the lane change intention using the dataset constructed in Section 2. SVM is a machine learning method to find the maximum classification interval, which is applied to lane change intention recognition, lane departure warning and collision avoidance [35], [36].

In the experiment, we select 2231 data samples from NGSIM as training set (1125 for non-lane change, 919 for left lane change and 187 for right lane change) and 1118 data samples from HIL simulation as test set (562 for non-lane change, 444 for left lane change and 112 for right lane change) as shown in Fig. 7. 0.5 seconds, 1seconds, 2seconds, 3seconds, and 4seconds time span datasets are proposed to compare the performance of the proposed intention prediction controller and that of SVM. The settings of the Multi-LSTM network model are shown in Table 1. Based on the conclusion in Section 4, in order to achieve the higher accuracy, 400 hidden layers are selected to construct the memory neural network. Then, the whole network is trained for 7400 iterations with a learning rate of 0.001. With the increase of training iterations, the accuracy for training dataset approaches 100% and the loss of the whole network reaches the minimum value of 0.00012. Meanwhile, a large learning rate will cause the loss function to ignore the minimum loss and too little learning rate means that the training will progress very slowly. Based on former researches and experiences, the learning rate is set as 0.001.

Figure 8, 9, 10, and 11 show the overall performance of lane change intention prediction and the individual effects of three different intentions between the proposed Multi-LSTM model, SVM model and rule-based method. Figure 8 presents the prediction accuracy of Multi-LSTM is gradually raising from 0.7962 to 0.838, and 0.7435 to 0.8141 for SVM as the

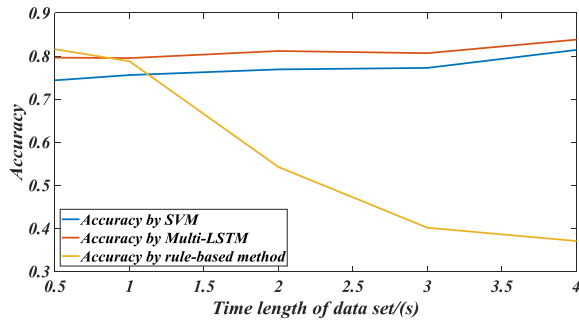

FIGURE 8. The accuracy of three methods.

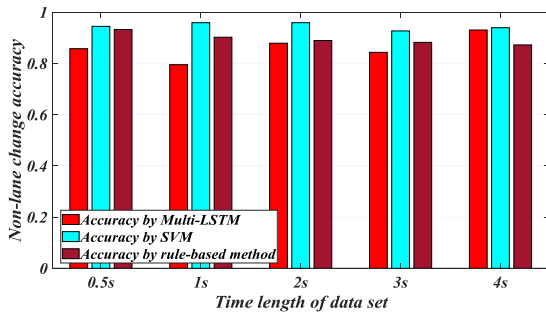

FIGURE 9. The accuracy of non-lane change of different methods.

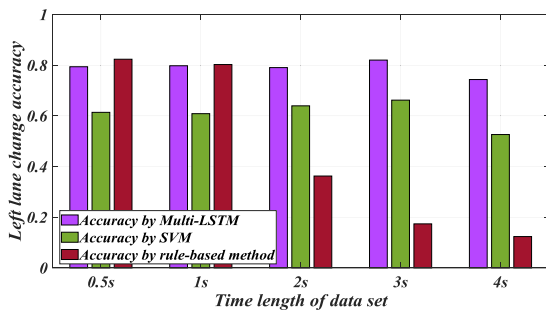

FIGURE 10. The accuracy of left lane change of different methods.

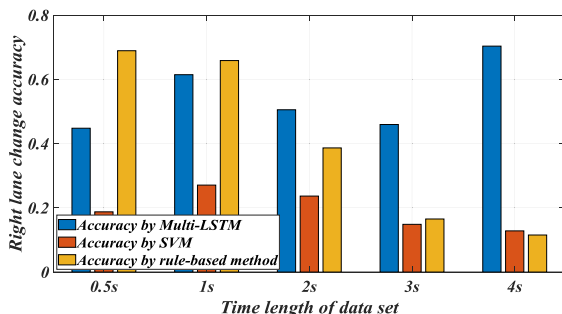

FIGURE 11. The accuracy of right lane change of different methods.

time length of data set increasing, but the performance of rule-based method is decreasing from 0.81563 to 0.37042, which indicates it has no ability to predict lane change intention. In general, our proposed Multi-LSTM network has a better prediction performance than that of SVM and rule-based method. As shown in Figure 9, the three intention prediction models are very accurate for the recognition of non-lane change, with an average accuracy more than 80%.

Meanwhile, SVM recognizer can achieve more than 90% recognition accuracy for non-lane change. In Figure 10, the maximum accuracy for left turn intention recognition using SVM is less than 70%, while the maximum accuracy of Multi-LSTM network model is more than 80%. And the rule-based method can achieve a similar performance compared with that of our proposed model with short length data set (0.5s and 1s), but the accuracy of rule-based method decreases deeply with prediction time increasing. What's more, the maximum recognition accuracy of SVM for right turn intention is less than 30% and the minimum value of recognition accuracy is only 12.82%, which means SVM has a completely poor ability to predict right turn intention. However, the maximum recognition accuracy for right turn using Multi-LSTM model exceeds 70%.

Based on the above analysis, our proposed Multi-LSTM model can not only get high overall lane change prediction accuracy, but also has advantages in the recognition for each lane change intention. compared with the recognition performance of SVM and rule-based method, the Multi-LSTM model can explore deeper features of data set to make up for the lack of samples because of the strong nonlinear characteristics of the model, which proves that the model is more robust to the influence of sample number on prediction results. On the contrary, as the number of single intention samples decreases, the prediction accuracy of SVM model declines rapidly, which means the model is highly dependent on the number of samples.

VI. CONCLUSION

In this paper, a vehicle lane change intention recognition controller based on LSTM network is proposed, which can not only get high recognition accuracy for three lane change intentions, but also show high robustness to the number of data samples. First, the lane change data set is established by extracting from NGSIM, which consists of three intention recognition samples: non-lane change, left lane change and right lane change. Then, based on the temporal characteristics of the lane changing data set, we establish a Multi-LSTM network to learn the lane changing characteristics and predict the lane change intention. the first LSTM network is constructed to extract lane changing features as many as possible and the second LSTM is proposed to predict the lane change intention, which can increase the nonlinear components of the model and improve the robustness for the number of samples. Furthermore, the influence of the number of hidden layers and the time length of data sample on the recognition accuracy is presented. Finally, by comparing with the lane change prediction performance of SVM, it is proved that the Multi-LSTM model is more suitable for vehicle lane change intention recognition. Applying the Multi-LSTM model to the field test will be the focus of the future work.

REFERENCES

- [1] F. Zhang, X. Hu, R. Langari, and D. Cao, "Energy management strategies of connected HEVs and PHEVs: Recent progress and outlook," *Prog. Energy Combustion Sci.*, vol. 73, pp. 235–256, Jul. 2019.

- [2] B. Xu, X. Hu, X. Tang, X. Lin, H. Li, D. Rathod, and Z. Filipi, "Ensemble reinforcement learning-based supervisory control of hybrid electric vehicle for fuel economy improvement," *IEEE Trans. Transp. Electrific.*, vol. 6, no. 2, pp. 717–727, Jun. 2020.
- [3] H. Zhang, J. Liang, and Z. Zhang, "Active fault tolerant control of adaptive cruise control system considering vehicle-borne millimeter wave radar sensor failure," *IEEE Access*, vol. 8, pp. 11228–11240, 2020.
- [4] F. Yan, K. Wang, B. Zou, L. Tang, W. Li, and C. Lv, "LiDAR-based multi-task road perception network for autonomous vehicles," *IEEE Access*, vol. 8, pp. 86753–86764, 2020.
- [5] H. M. Fahmy, M. A. A. E. Ghany, and G. Baumann, "Vehicle risk assessment and control for lane-keeping and collision avoidance at low-speed and high-speed scenarios," *IEEE Trans. Veh. Technol.*, vol. 67, no. 6, pp. 4806–4818, Jun. 2018.
- [6] N. Gageik, P. Benz, and S. Montenegro, "Obstacle detection and collision avoidance for a UAV with complementary low-cost sensors," *IEEE Access*, vol. 3, pp. 599–609, 2015.
- [7] L. Tang, F. Yan, B. Zou, K. Wang, and C. Lv, "An improved kinematic model predictive control for high-speed path tracking of autonomous vehicles," *IEEE Access*, vol. 8, pp. 51400–51413, 2020.
- [8] D. Moser, R. Schmied, H. Waschl, and L. del Re, "Flexible spacing adaptive cruise control using stochastic model predictive control," *IEEE Trans. Control Syst. Technol.*, vol. 26, no. 1, pp. 114–127, Jan. 2018.
- [9] L. Xiao and F. Gao, "Practical string stability of platoon of adaptive cruise control vehicles," *IEEE Trans. Intell. Transp. Syst.*, vol. 12, no. 4, pp. 1184–1194, Dec. 2011.
- [10] S. Lu, S. Cen, X. Hu, C. Lim, and J. Zhang, "Correction to the 'Integrated control of braking and steering subsystems for autonomous vehicle based on an efficient yaw moment distribution,'" *IEEE Trans. Ind. Electron.*, early access, Aug. 29, 2017.
- [11] X. Na and D. J. Cole, "Application of open-loop stackelberg equilibrium to modeling a Driver's interaction with vehicle active steering control in obstacle avoidance," *IEEE Trans. Human-Machine Syst.*, vol. 47, no. 5, pp. 673–685, Oct. 2017.
- [12] N. Kaempchen, B. Schiele, and K. Dietmayer, "Situation assessment of an autonomous emergency brake for arbitrary Vehicle-to-Vehicle collision scenarios," *IEEE Trans. Intell. Transp. Syst.*, vol. 10, no. 4, pp. 678–687, Dec. 2009.
- [13] Y. Xing and C. Lv, "Dynamic state estimation for the advanced brake system of electric vehicles by using deep recurrent neural networks," *IEEE Trans. Ind. Electron.*, vol. 67, no. 11, pp. 9536–9547, Nov. 2020.
- [14] J.-Y. Hsu, K.-L. Ku, T.-K. Jhang, H.-P. Lin, and C.-J. Yeh, "Integration and implementation of a lane keeping system with vehicle dynamics control," in *Proc. Int. Autom. Control Conf. (CACCS)*, Nov. 2017, pp. 1–6.
- [15] A.-T. Nguyen, C. Sentouh, and J.-C. Poupieul, "Driver-automation cooperative approach for shared steering control under multiple system constraints: Design and experiments," *IEEE Trans. Ind. Electron.*, vol. 64, no. 5, pp. 3819–3830, May 2017.
- [16] L. Li and P. Li, "Analysis of driver's steering behavior for lane change prediction," in *Proc. 11th Int. Conf. Intell. Hum.-Mach. Syst. Cybern. (IHMSC)*, Aug. 2019, pp. 71–75.
- [17] *National Motor Vehicle Crash Causation Survey Report to Congress*. National Highway Traffic Safety Administration, Washington, DC, USA, 2008.
- [18] J. Gao, H. Zhu, and Y. L. Murphey, "A personalized model for driver lane-changing behavior prediction using deep neural network," in *Proc. 2nd Int. Conf. Artif. Intell. Big Data (ICAIBD)*, May 2019, pp. 90–96.
- [19] A. Simić, O. Kocić, M. Z. Bjelica, and M. Milosevic, "Driver monitoring algorithm for advanced driver assistance systems," in *Proc. 24th Telecommun. Forum (TELFOR)*, Nov. 2016, pp. 1–4.
- [20] J. Nilsson, J. Fredriksson, and E. Coelingh, "Rule-based highway maneuver intention recognition," in *Proc. IEEE 18th Int. Conf. Intell. Transp. Syst.*, Sep. 2015, pp. 950–955.
- [21] D. Tran, J. Du, W. Sheng, D. Osipychyev, Y. Sun, and H. Bai, "A human-vehicle collaborative driving framework for driver assistance," *IEEE Trans. Intell. Transp. Syst.*, vol. 20, no. 9, pp. 3470–3485, Sep. 2019.
- [22] H. Mandalia and D. Salvucci, "Using support vector machines for lane-change detection," in *Proc. Hum. Factors Ergonom. Soc. 49th Annu. Meeting*, 2008, pp. 1–5.
- [23] X. Hu and F. Sun, "Fuzzy clustering based multi-model support vector regression state of charge estimator for lithium-ion battery of electric vehicle," in *Proc. Int. Conf. Intell. Human-Machine Syst. Cybern.*, Aug. 2009, pp. 392–396.
- [24] D.-F. Xie, Z.-Z. Fang, B. Jia, and Z. He, "A data-driven lane-changing model based on deep learning," *Transp. Res. C, Emerg. Technol.*, vol. 106, pp. 41–60, Sep. 2019.
- [25] Y. Zhang, Q. Lin, J. Wang, S. Verwer, and J. M. Dolan, "Lane-change intention estimation for car-following control in autonomous driving," *IEEE Trans. Intell. Vehicles*, vol. 3, no. 3, pp. 276–286, Sep. 2018.
- [26] *Next Generation Simulation Fact Sheet*. Washington, DC, USA. [Online]. Available: ops.fhwa.dot.gov/trafficanalysisstools/ngsim.htm
- [27] H. Yeo, A. Skabardonis, J. Halkias, J. Colyar, and V. Alexiadis, "Over-saturated freeway flow algorithm for use in next generation simulation," *Transp. Res. Rec., J. Transp. Res. Board*, vol. 2088, no. 1, pp. 68–79, Jan. 2008.
- [28] Y. Hou, P. Edara, and C. Sun, "Modeling mandatory lane changing using bayes classifier and decision trees," *IEEE Trans. Intell. Transp. Syst.*, vol. 15, no. 2, pp. 647–655, Apr. 2014.
- [29] X. Shi, Z. Chen, H. Wang, D.-Y. Yeung, W.-K. Wong, and W.-C. WOO, "Convolutional LSTM network: A machine learning approach for precipitation nowcasting," in *Proc. Int. Conf. Neural Inf. Process. Syst.*, 2015, pp. 802–810.
- [30] A. Alahi, K. Goel, V. Ramanathan, A. Robicquet, L. Fei-Fei, and S. Savarese, "Social LSTM: Human trajectory prediction in crowded spaces," in *Proc. IEEE Conf. Comput. Vis. Pattern Recognit. (CVPR)*, Jun. 2016, pp. 961–971.
- [31] B. Liu, Z. Ding, and C. Lv, "Distributed training for multi-layer neural networks by consensus," *IEEE Trans. Neural Netw. Learn. Syst.*, vol. 31, no. 5, pp. 1771–1778, May 2020.
- [32] M. Schreier, V. Willert, and J. Adamy, "A combined model-and learning-based framework for interaction-aware maneuver prediction," vol. 47, no. 1, pp. 24–32, 2017.
- [33] M. Bahram, M. Z. Q. Chen, Z. Zeng, X. Yu, "Fuzzy control for uncertain vehicle active suspension systems via dynamic sliding-mode approach," *IEEE Trans. Intell. Transp. Syst.*, vol. 17, no. 6, pp. 1538–1550, 2016.
- [34] S. Dai, L. Li, and Z. Li, "Modeling vehicle interactions via modified LSTM models for trajectory prediction," *IEEE Access*, vol. 7, pp. 38287–38296, 2019.
- [35] R. S. Tomar, S. Verma, and G. S. Tomar, "SVM based trajectory predictions of lane changing vehicles," in *Proc. Int. Conf. Comput. Intell. Commun. Netw.*, Oct. 2011, pp. 716–721.
- [36] E. Salari and D. Ouyang, "Camera-based forward collision and lane departure warning systems using SVM," in *Proc. IEEE 56th Int. Midwest Symp. Circuits Syst. (MWSCAS)*, Aug. 2013, pp. 1278–1281.



LIANG TANG received the Ph.D. degree in mechanical engineering from the Department of Automotive Engineering, Tsinghua University, Beijing, China, in 2010. Since 2014, she has been an Associate Professor with Beijing Forestry University. From 2015 to 2016, she was a Visiting Scholar with the University of Michigan, USA. She was a Visiting Scholar with the University of Michigan, USA, in 2018. Her research has been funded by the National Science Foundation and the

Beijing Science Foundation and Auto Industry. Her research interests include vehicle dynamics and control and injury biomechanics in motor-vehicle crashes by a multidisciplinary approach.



HENGYANG WANG (Student Member, IEEE) received the B.E. degree in electrical engineering and automation from Beijing Jiaotong University, Beijing, China, in 2018, where he is currently pursuing the Ph.D. degree in electrical engineering with the School of Electrical Engineering.

His research interests include intelligent vehicle perception and intelligent vehicle control.

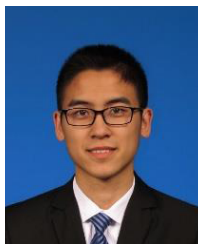

WENHAO ZHANG received the bachelor's degree in automotive engineering from Tsinghua University, Beijing, China, in 2017, where he is currently pursuing the master's degree in mechanical engineering with the School of Vehicle and Mobility. His research interests include vehicle dynamics and control and autonomous driving.



ZHONGYI MEI received the B.S. degree in automobile service engineering from the School of Automotive Engineering, Wuhan University of Technology, Wuhan, China, in 2019. He is currently pursuing the M.S. degree in mechanical engineering with the School of Technology, Beijing Forestry University, Beijing, China. His research interest includes vehicle dynamics and control.



LIANG LI (Senior Member, IEEE) received the Ph.D. degree in mechanical engineering from the Department of Automotive Engineering, Tsinghua University, Beijing, China, in 2008.

From 2011 to 2012, he was a Researcher with the Institute for Automotive Engineering, RWTH Aachen University, Aachen, Germany. Since 2017, he has been a Tenured Professor with Tsinghua University. His research interests include vehicle dynamics and control, adaptive and nonlinear system control, and hybrid vehicle develop and control. He received the China Automotive Industry Science and Technology Progress Award for his achievements in the hybrid electrical bus, in 2012, and the National Science Fund for Excellent Young Scholars of China, in 2014. He is currently an Associate Editor of *IET Intelligent Transport Systems* and *PLOS One*.

• • •