

A Look-Ahead Method for Forecasting the Concrete Price

Qing Liu^{1,2}, Minghao Huang², Woon-Seek Lee^{2*}

¹School of Economics and Management, Huainan Normal University, Huainan, China

²Graduate School of Management of Technology, Pukyong National University, Busan, South Korea

Email: *liuq2012@pukyong.ac.kr

How to cite this paper: Liu, Q., Huang, M.H. and Lee, W.-S. (2022) A Look-Ahead Method for Forecasting the Concrete Price. *Journal of Applied Mathematics and Physics*, **10**, 1859-1871.
<https://doi.org/10.4236/jamp.2022.105127>

Received: April 25, 2022

Accepted: May 28, 2022

Published: May 31, 2022

Abstract

Price movement of building materials increases the uncertainty of architectural planning. As a basic building material, commercial concrete is an important part of various construction costs. It is of great significance to predict its price change trend in advance. In this paper, a univariate autoregressive series is constructed based on the daily average price of concrete in major cities in China; then it uses a combined model of Convolutional Neural Network (CNN) and Long Short-Term Memory Network (LSTM) to extract the spatial and temporal rules of time series, to achieve accurate prediction of the trend of concrete price changes 10 days ago. The prediction accuracy rate of the model is 97.13%, and the precision, recall rate, and F1 score are: 97.15%, 97.27%, and 97.20%, respectively. The prediction result is of great significance to various architectural planning.

Keywords

Price Forecasting, Concrete, Deep Learning, Autoregression

1. Introduction

Digital empowerment, smart cost, and an increasingly competitive environment have brought new challenges to building construction planning. In the construction cycle of several months, movements in material prices have increased the economic risks in construction. Commercial concrete is one of the main materials for various types of buildings, such as railways, highways, tunnels, bridges, buildings, etc., and is an important part of construction costs. Accurately predicting the price changes of commercial concrete is of great significance to the construction planning and economic risk control of buildings. The complex market environment makes price forecasting a challenging problem. Scholars at

home and abroad have carried out research on the price forecasting of various commodities from various perspectives. However, we have not found any research papers related to the price forecasting of commercial concrete.

References [1] [2] [3] respectively forecast and study the fluctuating electricity prices in the electricity markets of Australia, Spain, and the United States. These studies all use wavelet transform (WT), which is widely used in the field of electricity price prediction, as the data preprocessing algorithm. They are very similar in data preprocessing but differ in model selection and parameter selection. References [4] [5] [6] [7] conducted a forecast study on the price fluctuation of the energy market. Reference [4] compared the forecasting ability of forecast combination and contraction method in predicting oil price fluctuation. Reference [5] developed an improved oil price prediction model based on the support vector machine (SVM) algorithm. Reference [6] demonstrates how the real-time forecast accuracy of oil price forecast models changes over time, and a forecast combination method is proposed to address this instability. Reference [7] proposes a real-time forecasting procedure that utilizes multiple factors with different sampling frequencies to predict weekly carbon prices. Stock and futures markets are also the main research fields of price forecasting. References [8] [9] [10] studied stock forecasting from different perspectives. In [9], the language sentiment in Twitter is added to the deep learning model through natural language processing, which enhances the performance of stock price prediction. In addition, the price prediction of agricultural products is also a research topic that scholars like. Reference [14] considered the impact of seasonal factors on vegetable prices and used the seasonal autoregressive integrated moving average model (SARIMA) to predict the price of cucumbers.

To sum up, in the field of price forecasting, the research fields of scholars mainly focus on electricity [1] [2] [3], energy [4] [5] [6] [7], stock futures [8] [9] [10], cryptocurrency [11] [12] [13], agricultural products [14] and other fields that have a direct and important impact on economic life; although the price fluctuation of building materials is of great significance to architectural planning, the relevant price forecasting research is rarely concerned by scholars. In addition, researchers mostly focus on predicting the accurate price of commodities (or quantitative prediction), while predictions about commodity price trends are rare [12], and researchers usually use complex feature extraction methods [2] [3] [10] [11] [13] feature data to predict prices, which makes the selection of features and advanced processing of features, particularly important, and feature processing directly affect the performance of the prediction model.

In a complex market game, it is a difficult and complicated project to select characteristic variables that have a direct impact on concrete prices to construct appropriate panel data or multivariate time series (MTS), and whether the selection of feature variables is appropriate or not and the availability of data will directly affect the performance of the prediction model. Therefore, we took another approach to construct a univariate time series (UTS) based on the daily average price of concrete in major cities in China. The univariate time series is auto-

regressive. Therefore, we take another approach to construct an autoregressive series based on the daily average price of concrete in major cities in China, which is a special univariate time series (UTS). The historical price data contains the law of price fluctuations, we try to mine these kinds of rules and transform the concrete price prediction problem into a time series classification (TSC) problem.

This paper presents a novel expression of the above autoregressive sequence data and folds each time series into a set of highly correlated graph data. These graphs show the spatial rules of time series from different perspectives, which can be directly trained with a convolutional neural network. In this paper, a convolutional neural network is used to extract the spatial rules of time series, supplemented by a long short-term memory network to extract the time series rules of time series, to achieve an accurate prediction of the concrete price trend 10 days ago. Experimental results show that the prediction accuracy rate of the CNN-LSTM combination model is 97.13%, and the precision, recall rate, and F1 score are 97.15%, 97.27%, and 97.20%, which can accurately and accurately predict the price trend of concrete, and is of great significance to all kinds of construction investment planning.

The main contributions of this paper are as follows:

- 1) Accurate prediction of concrete price changes 10 days ago has been achieved, which is of great reference significance for all kinds of building construction planning.
- 2) A combined CNN-LSTM model is constructed, which can be used for reference by other time series classification tasks.

The rest of this paper is organized as follows: Section 2 is the related work of this research, Section 3 presents the network model architecture, Section 4 is experiments and results, and Section 5 is the conclusion and outlook.

2. Related Work

This section mainly introduces three models related to the research: Autoregressive Sequence (ARS), Convolutional Neural Network (CNN), and Long Short-Term Memory Network (LSTM).

2.1. Autoregressive Series

Suppose $\{X_1, X_2, \dots, X_N\}$ are time series training samples with number N , $\{y_1, y_2, \dots, y_N\}$ are the class labels corresponding to the training samples and $y_i \in 0, 1, \dots, C$, so time series training set D can be expressed as $\{(X_1, y_1), (X_2, y_2), \dots, (X_N, y_N)\}$. In deep learning, it is often necessary to perform one-hot encoding on the category labels $\{y_1, y_2, \dots, y_N\}$, at this time, y_i is represented as a vector Y_i , and the encoded time series training set D can be represented as $\{(X_1, Y_1), (X_2, Y_2), \dots, (X_N, Y_N)\}$. The label y_i or Y_i is the result label corresponding to the feature vector X_i , and the feature vector X_i is the panel data at the moment of the label data y_i or Y_i , so the goal of time series

classification (TSC) is to predict label of test instance, which is the process of using feature vector X of the test instance to predict the class label y .

Autoregressive sequence (ARS) is a special kind of time series, as the name suggests, it does not use feature data X to predict classification label y , but uses X to predict X itself, which is a regression of the variable itself, and the basic logic of an autoregressive sequence can be described by the following formula:

$$X_{t+d} = f(X_t, X_{t-1}, \dots) \quad d \in (1, 2, 3, \dots).$$

If the data of X_{t-1} is used to predict the result of X_{t+d} , it is called a 1st-order autoregressive sequence model or ARS(1), at this time $X_{t+d} = f(X_t, X_{t-1})$, so that by analogy, ARS(2) model can be described as $X_{t+d} = f(X_t, X_{t-1})$, and the ARS(p) model can be described as $X_{t+d} = f(X_t, X_{t-1}, \dots, X_{t-p+1})$.

To sum up, the autoregressive sequence analyzes the deterministic or uncertain relationship between the past and the future through the observation of historical data in the time axis to predict possible future observations. The autoregressive analysis is a special kind of time series classification, which provides a new path for price trend prediction.

2.2. Convolutional Neural Network

Fully connected networks will squash data of various shapes into 1-dimensional data input, which makes the shape of the data ignored, for example, typical image data is a 3-dimensional shape of height, width, and channel, this shape contains important spatial information, ignoring this spatial information will greatly reduce the recognition probability of the image.

The convolutional neural network replaces the cyclic structure of the fully connected network Affine-RELU with the typical Convolution-RELU-Pooling cyclic structure, which makes the convolutional neural network completely retain the spatial characteristics of the data. Today, convolutional neural networks are widely used in speech recognition, image recognition, and various classification tasks.

The advantage of CNNs is that they can directly learn the rules of feature data, reduce complex feature engineering, and the impact of these feature engineering on classification results. As shown in **Figure 1**, in the time series classification task, convolution can be seen as applying a sliding filter on the time series, applying multiple filters to a time series will produce a multivariate time series with the same dimensions as the number of filters. At the same time, CNN has the characteristics of weight sharing, which enables it to maintain translation invariance when learning time series, this is a huge improvement over fully connected networks because the timestamps of each time series in fully connected networks have their weights, which leads to loss of temporal information [15].

As shown in **Figure 1**, a filter with a shape of (3, 3) means that three-time series is extracted each time, and three feature data of three subsequences are extracted for each slide with a stride of 1, which is an advanced way of extracting time-series features. For the filter F_j (with $j \in 0 \dots FN - 1$), as j becomes larger,

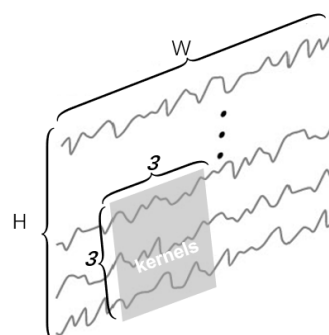

Figure 1. Filter features extraction.

the extracted information becomes more and more complex, from the edge, texture, and gradually to the internal features of the texture, the extracted feature information is more and more advanced, and each step of the slide extracts a section feature of the time series, multiple filters obtain multiple information mirrors of the time series.

2.3. LSTM Network

In traditional neural networks (including CNN), the input and output are independent of each other, but the subsequent output of some tasks is related to the previous content, and the local information is not enough to enable the subsequent tasks to proceed, such as machine translation and sequence processing. The emergence of a Recurrent Neural Network (RNN) solves this problem. RNNs use the output of the previous moment as part of the input of the next moment, which is conducive to the processing of sequence data.

If the convolutional neural network is good at obtaining spatial features, then the recurrent neural network is good at extracting the features of the time dimension. The advantage of the recurrent neural network is that it can transmit information from the past to the future, however, traditional recurrent neural networks may have problems with gradient vanishing and gradient explosion, as the network depth increases, subsequent nodes will gradually become weaker in their perception of previous nodes, and when the input sequence is too long, it is easy to lose the state information of the sequence header. In general, the problem of gradient explosion can be solved by gradient clipping, but the problem of gradient vanishing is not so easy to deal with until the emergence of Long Short-Term Memory (LSTM), LSTM calculates the state in the form of accumulation instead of product, and by introducing the concept of the gate, remember what should be remembered and forget what should be forgotten, which alleviates the problem of gradient dispersion to a certain extent, and then, recurrent neural networks and their variants have been further implemented and developed, and have achieved good results in issues including machine translation, QA systems, speech recognition, and text classification.

As a variant of RNN, LSTM has the native ability to process time series, and they can transmit information from the past to the future, which makes LSTM,

like CNN, widely used in various spatiotemporal sequence classification and prediction tasks [16] [17], in the field of class price prediction, LSTM also has many successful applications [3] [10].

3. Combined Model of CNN-LSTM

This section mainly expounds on the network architecture used in the study, including three aspects: the graphical representation of time series, the CNN architecture, and the LSTM network architecture.

3.1. Graphical Representation of Time Series

Univariate time series cannot take advantage of the advantages of convolutional neural networks in the field of image processing, to make them directly learned by convolutional neural networks, it is often necessary to graphically represent the data. Traditional feature map extraction schemes are often complex and single in expression, and cannot fully display the spatial rules of time series. We present a novel expression of the above autoregressive sequence data, which collapses each time series into a set of highly correlated graphical data, which show the spatial rules of time series from different perspectives.

As shown in **Figure 2**, we decompose the time series length T by multiplicative decomposition $T = H \times W$, and this decomposition will have multiple decomposition methods. We use an enumeration method to obtain a set of all folded shapes, this set can be represented as $M = \{(H_1, W_1), (H_2, W_2), \dots, (H_m, W_m)\}$. where the minimum value of H or M is There is a limit, otherwise the convolution operation may not be possible. The minimum value of H or M is limited here, otherwise the convolution operation may not be possible. In addition, in some cases, the number of multiplicative decompositions of T is small, and even

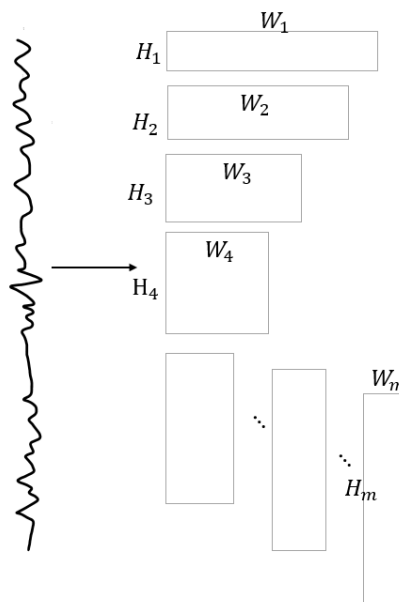

Figure 2. Multiple graphical representations of time series.

the decomposition operation of $T = H \times W$ cannot be performed, at this point, we can perform a zero-fill operation on the original time series, and fill in several zeros at the tail of the time series feature data, so that it can be decomposed in various forms, this is a padding-like operation that will not negatively affect the classification performance of the data. We use x to represent the padding length, at this time $T + x = H \times W$.

Algorithm 1 describes the enumeration process of the above-mentioned multiplicative decomposition of the length of time series. The original data set D_{raw} is represented graphically according to the shape in M , and a set of data sets with all shapes $D = \{D_1, D_2, \dots, D_m\}$, Each dataset in D contains a side of the spatial characteristics of the time series, and their combination will give a more comprehensive description of the spatial characteristics of the time series, which is very beneficial to TSC. This is like taking pictures of a person from different angles, showing her full pose, this scheme is conducive to obtaining the best spatial representation of time series data, and is very simple and intuitive

3.2. Convolutional Neural Network Architecture

In this paper, a simple convolutional neural network is designed to extract the spatial rules of time series, which only contains 2 convolutional layers and 1 pooling operation. At the end of the network, a fully connected layer is used to flatten the data for output. RELU activation function is used for the layer and the pooling layer, the convolutional layer, and the fully connected layer, and the network structure is shown in **Figure 3**. RELU activation function is used between layers, and the network structure is shown in **Figure 3**.

Input: MSL : Minimum Side Length;

T : Time series length;

x : Zero padding length

Output: M : Enumerated collection of shapes

initialization : $M = \{\}$: Initially set the shape's collection to an empty collection

1. **for** $h \leftarrow MSL$ **to** $T + x$ **do**
2. remainder $\leftarrow T \% h$
3. $w \leftarrow T / h$
4. **if** remainder = 0 and $w \leq MSL$ **then**
5. add (h, w) to M
6. **end**
7. **end**
8. **return** M

Algorithm 1. Time series folding enumeration process.

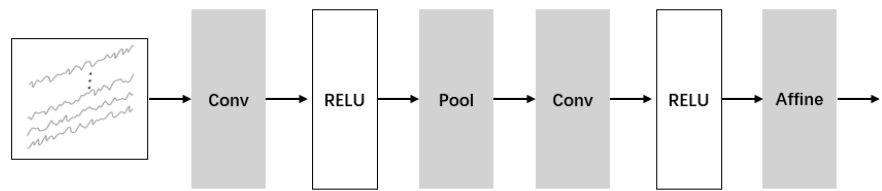

Figure 3. Convolutional neural network architecture.

The graphically represented time series is used as the input of the convolutional neural network, and the initialization weight θ of the data input obeys a Gaussian distribution with mean 0 and variance $2/(in + out)$ (XAVIER initialization).

The first convolutional layer uses 20 filters ($FN = 20$), the shape of each filter is $(3, 3)$, and the stride of the convolution operation is 1. The first convolutional layer is followed by a max-pooling of shape $(2, 2)$, which is a non-linear form of downsampling performed between two consecutive convolutional layers. The output of the pooling layer is directly passed to the second convolutional layer with a filter shape of $(2, 2)$ and a stride of 2. This convolution further extracts the high-level features of the feature map and passes the output to a full connection layer, the fully connected layer will squash the output of the features by the convolutional layer to 200.

3.3. LSTM Network Architecture

Univariate time series can be directly learned by the LSTM network without any preprocessing, and LSTM has the advantage of learning the temporal rules of the data, which makes it attract the attention of time series researchers from the beginning. As shown in **Figure 4**, time-series feature-length T is the input length of the LSTM net, the first LSTM layer outputs a feature vector of length 800, which is to capture the deep features from the input sequence of T values. The output of the first LSTM is passed to the second LSTM layer, and the second LSTM performs deep extraction of the input 800 feature data and outputs 400 high-level features. The output of the second LSTM is passed to a fully connected layer, which flattens the feature data and outputs 100 features, RELU activation function is applied between each layer.

3.4. Net Combination

As shown in **Figure 5**, after using a convolutional neural network and long short-term memory network to extract the spatial rules and time series rules of the time series, the output data of the two are combined to form a new data sequence. The new data will be input to a fully connected layer and the final classification output is made through the SoftMax function. This combined model makes full use of the advantages of convolutional neural networks that are good at extracting spatial rules of images and LSTM networks that are good at extracting temporal rules of data.

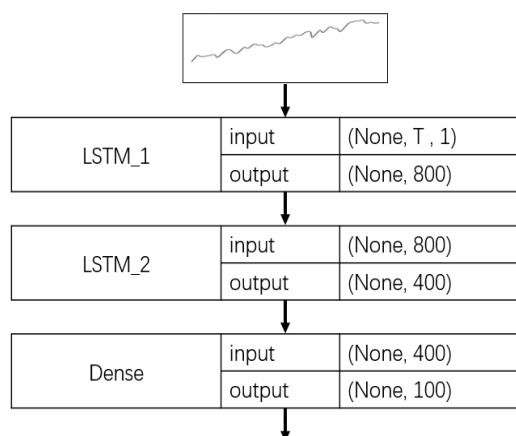

Figure 4. LSTM network architecture.

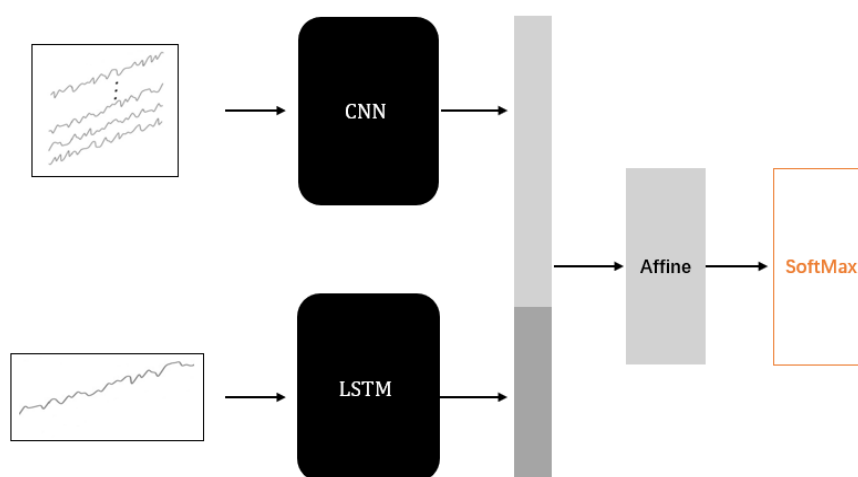

Figure 5. CNN-LSTM combined network.

The input to the combined model is two datasets: the graphically represented time series and the original time series, since we represent the time series as a set of graphical data, we need to train the model once for each graphical representation and validate the model with a validation set to obtain the best predictive model.

4. Experiment

We use the network architecture described in the third part of the article to conduct an empirical study on concrete price forecasting, with prediction accuracy as the main metric, precision, recall, and F1 score are used as secondary metrics to comprehensively evaluate the prediction of three types of data samples.

The CNN-LSTM combined model is used to run the training dataset for 20 rounds; after each round of training, the model is used to predict the label of the test dataset to observe the prediction performance of the model; experimental results are shown in **Table 1**.

Table 1. Predicted results of 20 epochs training.

nEpochs	Accuracy	Precision	Recall	F1 Score
1	0.4877049	0.5140877	0.4634291	0.5742972
2	0.5532787	0.5958559	0.5600603	0.5280951
3	0.6147541	0.6898585	0.6214168	0.6017285
4	0.7786885	0.7777344	0.7792497	0.7774454
5	0.8401639	0.8480348	0.8441942	0.8405346
6	0.9098361	0.9121541	0.9089332	0.9099650
7	0.7868852	0.8542175	0.7838634	0.7912077
8	0.8155738	0.8610672	0.8117310	0.8168633.
9	0.8975410	0.9032191	0.8951889	0.8976688
10	0.9344262	0.9348024	0.9356402	0.9347699
11	0.9467213	0.9465214	0.9492020	0.9469480
12	0.9549180	0.9552030	0.9569539	0.9547717
13	0.9590164.	0.9585008	0.9609667	0.9592337
14	0.9631148	0.9630292	0.9648883	0.9637704
15	0.9713115	0.9714511.	0.9726858	0.9719628
16	0.9713115	0.9714511	0.9726858	0.9719628
17	0.9713115	0.9714511	0.9726858	0.9719628
18	0.9713115	0.9714511	0.9726858	0.9719628
19	0.9713115	0.9714511	0.9726858	0.9719628
20	0.9713115	0.9714511	0.9726858	0.9719628

The experimental results show that after 15 rounds of training, the prediction performance of the model tends to be stable, and the prediction accuracy rate of the concrete price change trend is 97.13%, which is an excellent prediction result, and the prediction results of various label samples are very uniform. **Figure 6** shows the change curve of the prediction accuracy in 20 rounds of training.

Figure 7 shows the prediction confusion matrix after 15 rounds of training, from which we can see more detailed prediction results. The total number of test samples is 244, and there are 237 samples whose predicted labels are consistent with the real labels, accounting for 97.13% of the total number of samples, of which of the 86 samples with unchanged prices, 3 were mispredicted, 85 samples with rising prices, 4 were mispredicted, and all samples with falling prices were correctly predicted.

The experimental results show that the prediction of concrete price movement based on autoregression and deep learning is feasible, and the price changes of concrete can be accurately predicted for a long time, which is of great significance to various architectural planning.

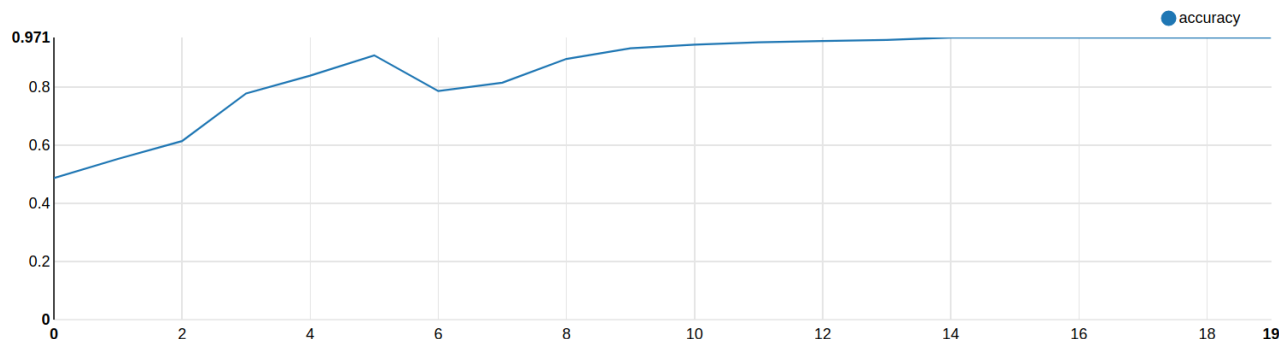

Figure 6. Variation curve of accuracy.

	0	1	2	
83	2	1	0	= 0
3	81	1	1	= 1
0	0	73	2	= 2

Figure 7. Confusion matrix of price change trend prediction.

5. Conclusion and Outlook

This paper uses the concrete price data from 2013-10-23 to 2021-01-20 to construct a univariate autoregressive sequence dataset, and graphically represents the time series in a flat and folded manner, so that the dataset can be directly learned by CNN, and the output of CNN is transmitted to the LSTM network, which realizes the feature learning of the spatial rules and sequence rules contained in the time series, and the combined model of CNN-LSTM realizes the accurate prediction of the trend of concrete price movement 10 days ahead, and the prediction accuracy rate reaches 97.13%, which is an excellent result of the current price trend prediction based on autoregressive series, which can accurately predict the market trend and is of great significance to all kinds of architectural planning.

At present, there are still some problems in this study. We have achieved accurate prediction of price trends, but we have not given the magnitude of price changes, which will cause certain difficulties for decision-makers in construction planning. In addition, the use of autoregressive series for price prediction avoids the trouble of various market factors but also ignores the impact of various market factors on price factors. We will consider these issues in future research.

Conflicts of Interest

The authors declare no conflicts of interest regarding the publication of this paper.

References

- [1] Singh, N., Mohanty, S.R. and Shukla, R.D. (2017) Short Term Electricity Price Forecast Based on the Environmentally Adapted Generalized Neuron. *Energy*, **125**, 127-139. <https://doi.org/10.1016/j.energy.2017.02.094>

- [2] Shafie-khah, M., Moghaddam, M.P. and Sheikh-El-Eslami, M.K. (2011) Price Forecasting of Day-Ahead Electricity Markets Using a Hybrid Forecast Method. *Energy Conversion and Management*, **52**, 2165-2169. <https://doi.org/10.1016/j.enconman.2010.10.047>
- [3] Qiao, W. and Yang, Z. (2020) Forecast the Electricity Price of U.S. Using a Wavelet Transform-Based Hybrid Model. *Energy*, **193**, Article ID: 116704. <https://doi.org/10.1016/j.energy.2019.116704>
- [4] Zhang, Y., Wei, Y., Zhang, Y. and Jin, D. (2019) Forecasting Oil Price Volatility: Forecast Combination versus Shrinkage Method. *Energy Economics*, **80**, 423-433. <https://doi.org/10.1016/j.eneco.2019.01.010>
- [5] Guo, X., Li, D. and Zhang, A. (2012) Improved Support Vector Machine Oil Price Forecast Model Based on Genetic Algorithm Optimization Parameters. *AASRI Procedia*, **1**, 525-530. <https://doi.org/10.1016/j.aasri.2012.06.082>
- [6] Mănescu, C.B. and Van Robays, I. (2014) Forecasting the Brent Oil Price: Addressing Time-Variation in Forecast Performance. *ERN: Other Econometrics: Applied Econometric Modeling in Agriculture*. <https://doi.org/10.2139/ssrn.2493129>
- [7] Zhao, X., Han, M., Ding, L. and Kang, W. (2018) Usefulness of Economic and Energy Data at Different Frequencies for Carbon Price Forecasting in the EU ETS. *Applied Energy*, **216**, 132-141. <https://doi.org/10.1016/j.apenergy.2018.02.003>
- [8] Shynkevich, Y., McGinnity, T.M., Coleman, S., Belatreche, A. and Li, Y. (2017) Forecasting Price Movements Using Technical Indicators: Investigating the Impact of Varying Input Window Length. *Neurocomputing*, **264**, 71-88. <https://doi.org/10.1016/j.neucom.2016.11.095>
- [9] Mehtab, S. and Sen, J. (2019) A Robust Predictive Model for Stock Price Prediction Using Deep Learning and Natural Language Processing. *Econometric Modeling: Capital Markets - Forecasting eJournal*: n. pag. <https://doi.org/10.2139/ssrn.3502624>
- [10] Huang, J.H., Zhong, M. and Hu, Q.C. (2021) LSTM Stock Prediction Model Based on Improved Particle Swarm Algorithm. *Journal of East China University of Science and Technology (Natural Science Edition)*, 1-12.
- [11] McNally, S., Roche, J. and Caton, S. (2018) Predicting the Price of Bitcoin Using Machine Learning. 2018 *26th Euromicro International Conference on Parallel, Distributed and Network-Based Processing (PDP)*, 339-343. <https://doi.org/10.1109/PDP2018.2018.00060>
- [12] Sun, X., Liu, M. and Sima, Z. (2020) A Novel Cryptocurrency Price Trend Forecasting Model Based on LightGBM. *Finance Research Letters*, **32**, Article No. 101084. <https://doi.org/10.1016/j.frl.2018.12.032>
- [13] Liu, C.M. (2009) Price Forecast for Gold Futures Based on GA-BP Neural Network. 2009 *International Conference on Management and Service Science*, 1-4. <https://doi.org/10.1109/ICMSS.2009.5302242>
- [14] Luo, C., Zhou, L.Y. and Wei, Q. (2013) Application of SARIMA Model in Cucumber Price Forecast. *Applied Mechanics and Materials*, **373-375**, 1686-1690. <https://doi.org/10.4028/www.scientific.net/AMM.373-375.1686>
- [15] Ismail Fawaz, H., et al. (2019) Deep Learning for Time Series Classification: A Review. *Data Mining and Knowledge Discovery*, **33**, 917-963. <https://doi.org/10.1007/s10618-019-00619-1>
- [16] Shi, X., Chen, Z., Wang, H., Yeung, D., Wong, W. and Woo, W. (2015) Convolutional LSTM Network: A Machine Learning Approach for Precipitation Nowcasting. *NIPS*.

- [17] Karim, F., Majumdar, S., Darabi, H. and Chen, S. (2018) LSTM Fully Convolutional Networks for Time Series Classification. *IEEE Access*, **6**, 1662-1669.
<https://doi.org/10.1109/ACCESS.2017.2779939>