

THE E-ELT CONSTRUCTION PROPOSAL

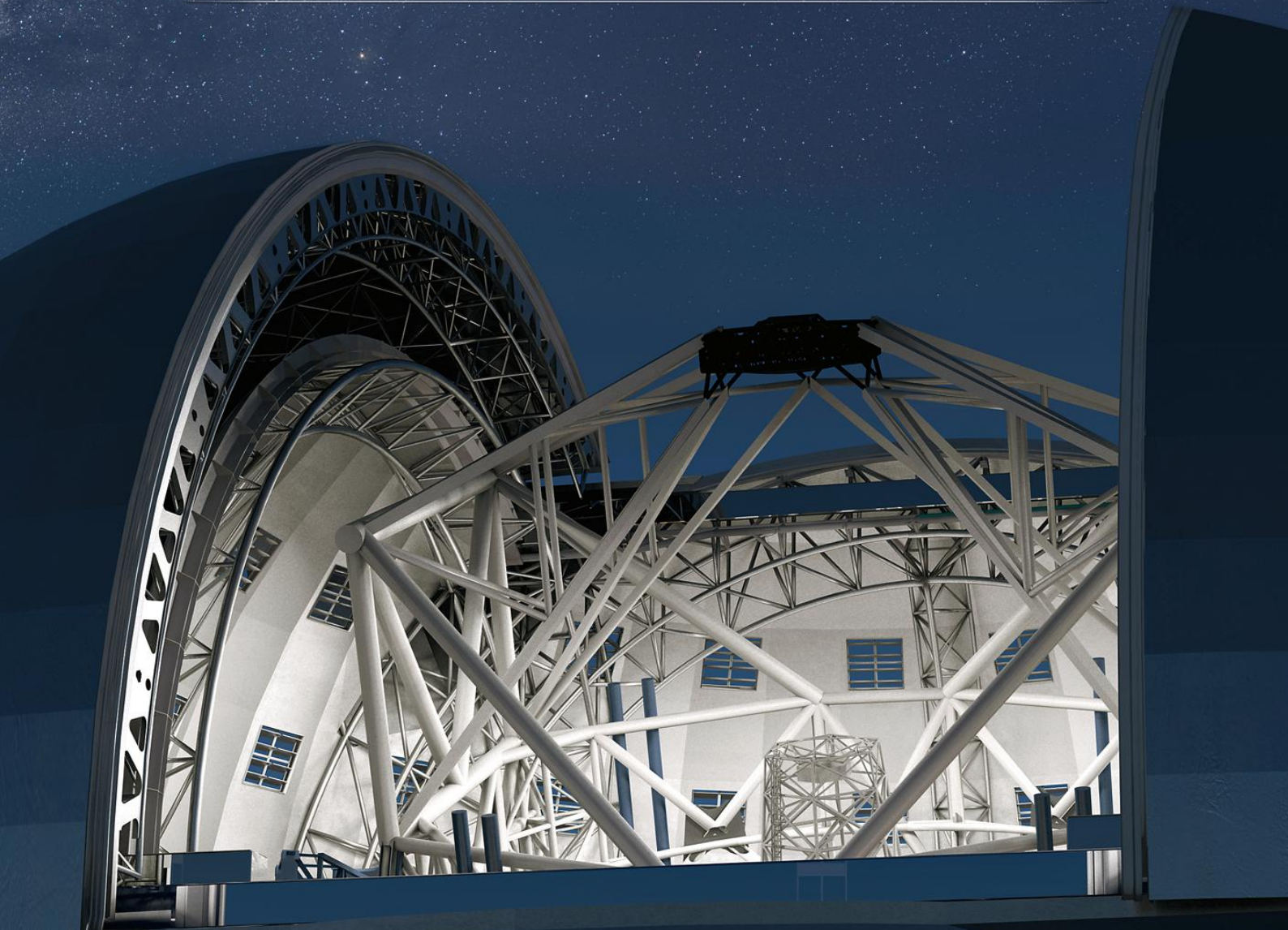

TABLE OF CONTENTS

Table of Contents	3
Executive Summary	5
1 Proposal Digest	7
1.1 Introduction	7
1.2 Science with the E-ELT	7
1.3 Towards the E-ELT Concept.....	12
1.4 Costing Philosophy	13
1.5 The Cost of the E-ELT	13
1.6 The Schedule of the E-ELT	14
1.7 Contingency	14
1.8 The Construction Review and the Delta Phase B	15
1.9 The Cost Review.....	15
1.10 39-metre Telescope Concept	16
1.11 The Instrumentation Plan	16
1.12 The Management Plan	17
1.13 Design Process.....	17
1.14 Operations	20
1.15 Conclusion.....	21
2 The Science Case.....	22
2.1 Contemporary Science	22
2.2 Synergies.....	40
2.3 Discovery Potential	43
2.4 Community Input to the Science Case.....	45
3 Technical Overview	52
3.1 Site and Infrastructure.....	52
3.2 Dome.....	60
3.3 Main Structure	77
3.4 Primary Mirror Units	94
3.5 Secondary Unit	123
3.6 Tertiary Unit	133
3.7 Quaternary Unit.....	139
3.8 Tip-tilt / Field-stabilisation Unit	145
3.9 Pre-focal Stations	150
3.10 Laser Guide Stars	157
3.11 Adaptive Optics Calibration Unit.....	160
3.12 Systems Engineering	161
3.13 Control Strategy.....	167
3.14 Control System	169
3.15 Assembly, Integration and Verification.....	173
4 E-ELT Instrument Roadmap	177
4.1 Introduction	177
4.2 Instrument Roadmap	179
4.3 Instrument Management Plan	188
4.4 Appendix: Phase A Studies of Instruments and Adaptive Optics Modules	193
5 Operations.....	207
5.1 Scope	207
5.2 Science Operations Goals, Services and Performance Monitoring	208
5.3 Observatory Management Overview	208
5.4 Operations Activities	212
5.5 E-ELT Operations Staffing.....	222
6 Economic Impact.....	232

6.1	Introduction	232
6.2	The Interaction between Astronomy, Industry and Innovation	232
6.3	Impact	233
6.4	Generating Knowledge	233
6.5	Providing Inspiration.....	234
6.6	Increasing the Skills Base	234
6.7	Building Industrial Capacity	234
6.8	Stimulating Innovation	234
7	Outreach and Education.....	237
7.1	The Value of Research Infrastructures for Society	237
7.2	The Impact of the E-ELT on Education and Public Outreach	238
8	Management Plan.....	243
8.1	Context.....	243
8.2	Governance	243
8.3	Project Team Structure and Responsibilities	243
8.4	Documentation	246
8.5	Work Breakdown Structure.....	247
8.6	Workflow	249
8.7	Communications.....	249
8.8	Staff Effort.....	249
8.9	Safety Management.....	250
8.10	Escalation	250
8.11	Project Control.....	250
8.12	Risk Management.....	251
8.13	Configuration and Change Management.....	251
8.14	Interface Management	252
8.15	Quality Management	252
8.16	Acceptance and Commissioning	252
9	Schedule and Budget.....	253
9.1	Schedule	253
9.2	Budget.....	254
9.3	Operational Costs	256
10	Acknowledgements	257
11	List of Acronyms.....	258

EXECUTIVE SUMMARY

This document presents a 1083 million euro (M€), 11-year programme for the construction of the European Extremely Large Telescope (E-ELT), the facility that will maintain the European Southern Observatory (ESO) in its leading position, providing research capabilities to the European astronomical community for the coming decades. Specifically, it is proposed to construct a 39.3-metre segmented optical telescope on Cerro Armazones as part of the La Silla Paranal Observatory, proven to be one of the world's best astronomical sites. The telescope will be operated from, and as part of, the existing Paranal site. This will create an outstanding facility in Chile for ESO Member States and will ensure that the maximum advantage can be taken of developments within astronomy and engineering.

This construction proposal includes not only the telescope structure and enclosure, but also all of the optics and instrumentation required to establish this unique scientific facility. Although it will be built as part of the existing infrastructure, extensions to roads, power supplies and services will be required to maintain and operate the facility. In addition, such a powerful telescope requires an array of instruments to achieve its ambitious science goals. This construction proposal includes a plan that will deliver several instruments to the telescope and provides the roadmap and technology development to enable further instrumentation for the future exploitation of the facility. This plan ensures that the telescope will operate with two instruments when it enters service, with one further instrument being delivered every two years thereafter.

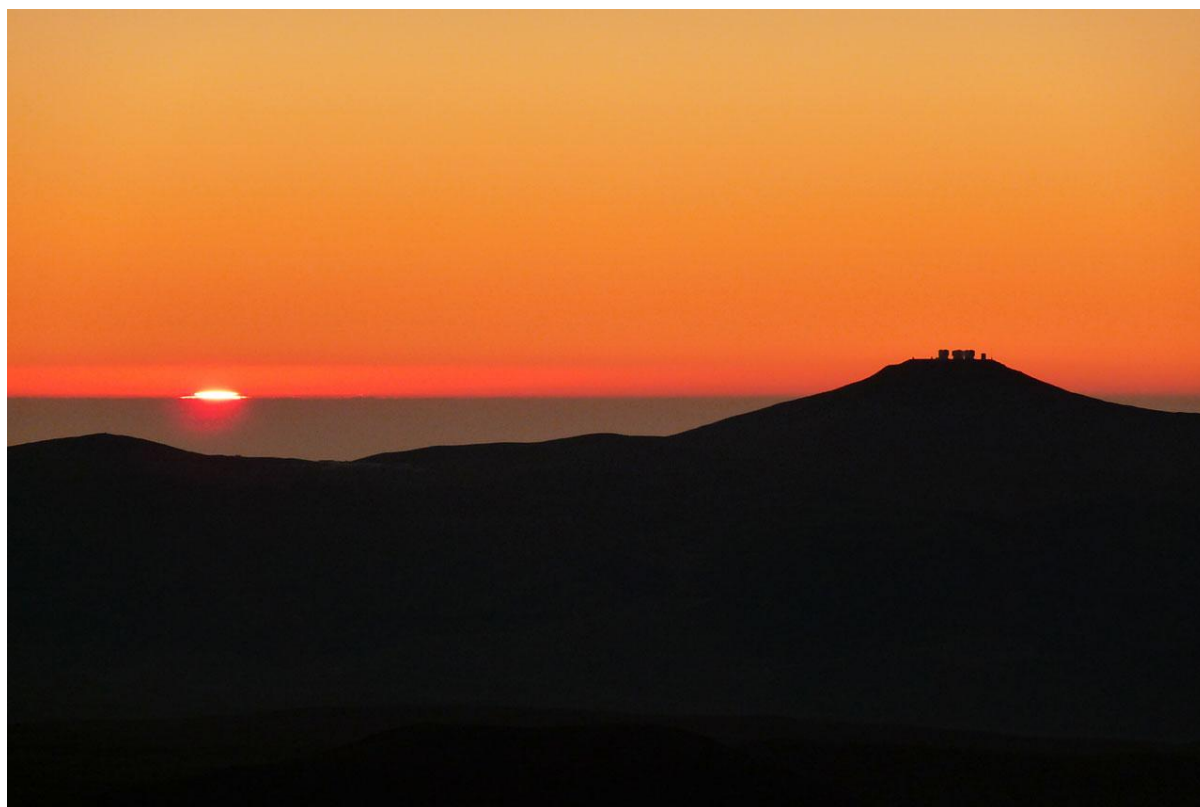

Figure 0.1. Sunset from Armazones (as will be seen at first light of the E-ELT).

The telescope has a mirror 39.3 metres in diameter, viewing an area on the sky about one ninth the size of the full Moon. The optical design itself is based on a novel five-mirror scheme that delivers exceptional image quality. The primary mirror consists of 798 segments, each 1.45 metres wide, but only 50 mm thick.

To take the maximum advantage of the site, the available technology and developments in instrumentation, the telescope will be adaptive, automatically correcting the disturbances introduced by the Earth's atmosphere before light enters the instruments. This follows the development of the adaptive optics deployed on Very Large Telescope (VLT) instrumentation and is an evolution of the adaptive optics facility

being developed for the VLT. The telescope will be delivered with an adaptive 2.4-metre mirror and will utilise six sodium laser guide stars.

Developing the E-ELT is a major endeavour in science, technology and engineering. Partnerships between institutes, universities and industry are already forming to build and exploit the telescope, its systems and instruments. In addition, the technologies and innovations being developed to deliver the E-ELT have already found, and will continue to find, wider applications within industry. Adaptive optics and lasers are two such areas already being spun out.

It is clear that a project of the size and technological challenge of the E-ELT will have a significant economic, cultural and scientific impact with a good chance of direct applications in areas such as medicine. The development of the E-ELT will generate knowledge, provide inspiration, increase our skills base and develop industrial capacity.

As the world's first and largest of a new generation of extremely large telescopes, the E-ELT will be in the prime position to take full advantage of the discoveries made by the James Webb Space Telescope (JWST).

The work carried out to date, primarily with industry, has reduced the risk for both the technical demands and the management of the programme. Following successful technical and financial reviews the programme is in an excellent position to move into construction, and the timing would ensure that Europe maintains its world lead in large astronomical facilities and the resulting research and discovery benefits.

This proposal is concerned mainly with the technological challenges of building the E-ELT, but its main aim is to provide a facility that will allow the community to tackle the exciting scientific questions addressed by the E-ELT science case. Should the governments of the ESO Member States come to a rapid decision about authorising the programme, the involvement and leadership of Europe in these discoveries will be assured.

1 PROPOSAL DIGEST

1.1 INTRODUCTION

The following chapter is intended to provide the reader with a complete overview of the essential elements of the E-ELT proposal. More in-depth material can be found in the remainder of this document.

1.2 SCIENCE WITH THE E-ELT

1.2.1 THE NEXT STEP IN FOUR HUNDRED YEARS OF DISCOVERIES

The European Extremely Large Telescope is the next giant step in four centuries of astrophysical research using telescopes. The year 2009 marked the passing of 400 years since Galileo Galilei first used a telescope for astronomical research, making the ground-breaking observations that would finally refute the geocentric Ptolemaic worldview and establish the heliocentric Copernican one. Since then, astronomical observations with telescopes have increasingly become the norm, until today, when observatories around the world host giant telescopes that work every available second to collect immense quantities of data. Each technological advance has brought new, and often totally unexpected, discoveries about our Universe, enriching our cultural heritage.

Over the last sixty years, astronomers have developed telescopes that are able to observe right across the electromagnetic spectrum. Antennas for long wavelength observations — radio, millimetre and sub-millimetre — were constructed, allowing many scientific breakthroughs, such as the discoveries of quasars, pulsars, the cosmic microwave background, and much more. Further, space observatories allowed observations to be pushed to shorter wavelengths, into the ultraviolet, X-ray and gamma-ray regimes. This opening up of the high-energy frontier generated a further flood of discoveries such as X-ray stars, gamma-ray bursts, black hole accretion discs, and other exotic phenomena. Previously unknown physical processes were taking place in the Universe around us. These astrophysical discoveries led to a number of Nobel Prizes in Physics (in 1974, 1978, 1993, 2002, 2006 and 2011) and to giant leaps in our understanding of the cosmos.

While astronomy has expanded to encompass these new wavelength bands, most discoveries are still made in the visible and near-infrared regimes, where stars predominantly emit their light. Technological advances in the 1980s and 1990s allowed scientists to build ever larger telescopes and ever more sensitive cameras. These instruments have opened up whole new areas of study. For example, the first exoplanets (planets orbiting other stars) were detected, and the current generation of 8–10-metre-class telescopes has even allowed us to take the first pictures of a few of these objects. Another example is the indirect detection of dark energy, previously completely unsuspected, but believed today to dominate and drive the expansion of the Universe. Our knowledge in astronomy continues to progress at an incredible pace, answering many questions, but also raising exciting new ones.

The European Extremely Large Telescope will be key in addressing these new questions, and in the following sections we seek to give a flavour of the kind of fundamental questions that it will finally answer. However, just as Galileo was astounded to find mountains on the Moon and moons orbiting Jupiter, the most exciting discoveries are probably those that we have not yet even imagined.

1.2.2 OPEN QUESTIONS FOR THE E-ELT

A revolutionary telescope such as the European Extremely Large Telescope is designed to answer some of the most prominent open questions in astrophysics.

1.2.2.1 EXOPLANETS: ARE WE ALONE?

For over a decade, we have known that exoplanets exist, but we have not yet been able to detect the faint signatures of Earth-like planets directly. The E-ELT will have the resolution to obtain the first direct

images of such objects, and even analyse their atmospheres for the biomarker molecules that might indicate the presence of life.

Are planetary systems like the Solar System common? How frequently do rocky planets settle in “habitable zones”, where water is liquid on the surface? Do the atmospheres of exoplanets resemble those of the planets in the Solar System? How is pre-biotic material distributed in protoplanetary discs? Are there signs of life on any exoplanets?

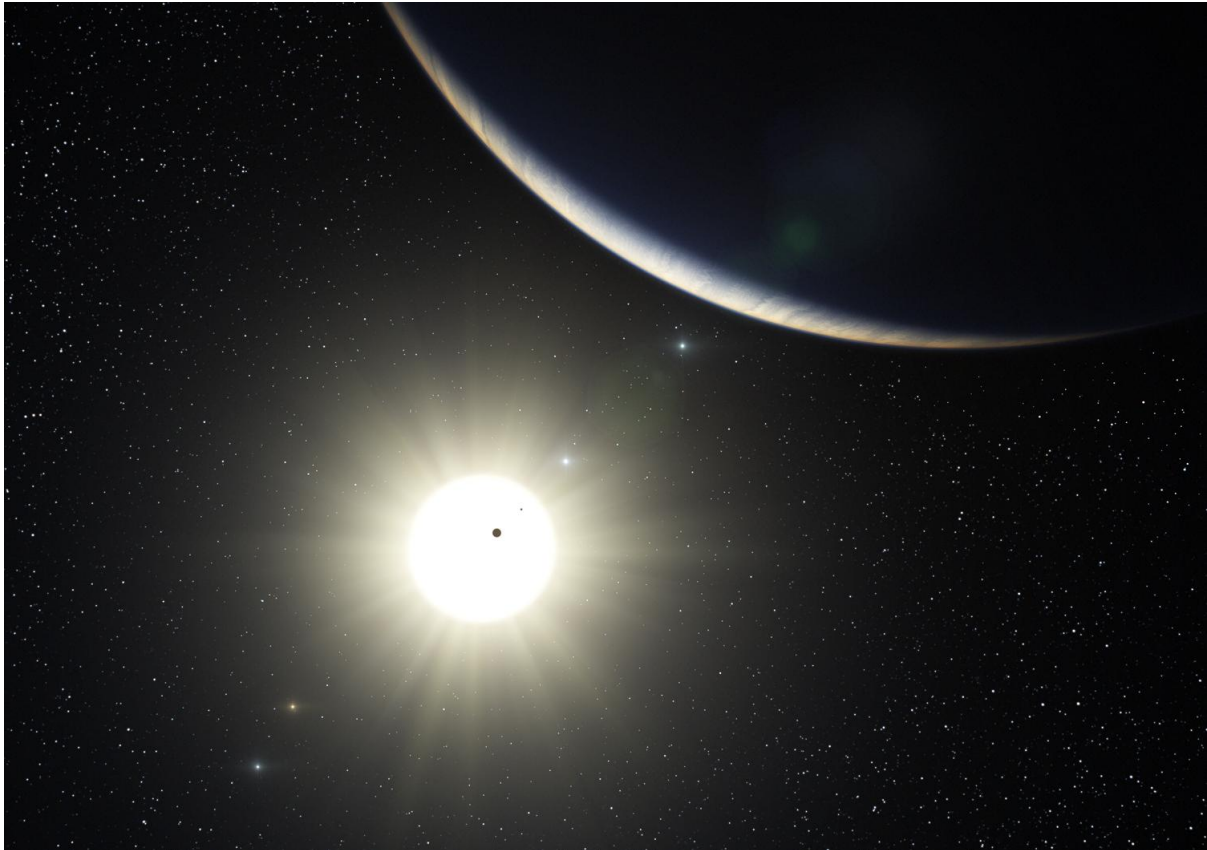

Figure 1.1. An artist's conception of a multi-planet system as they are commonly found now around nearby stars.

1.2.2.2 FUNDAMENTAL PHYSICS: ARE THE LAWS OF NATURE UNIVERSAL?

As far back in time and as far out in distance as we can observe, all phenomena that have yet been investigated seem to indicate that the laws of physics are universal and unchanging. Yet, uncomfortable gaps exist in our understanding: gravity and general relativity remain to be tested under extreme conditions, the amazingly rapid expansion (inflation) of the Universe after the Big Bang is not understood, dark matter seems to dominate the formation of the large-scale structure, but its nature remains unknown, and the recently discovered acceleration of the expansion of the Universe requires a mysterious dark energy that is even less comprehensible.

Were the physical constants indeed constant over the history of the Universe? How did the expansion history of the Universe really proceed? Can we infer the nature of dark energy?

1.2.2.3 BLACK HOLES: WHAT WAS THEIR ROLE IN SHAPING THE UNIVERSE?

Black holes have puzzled physicists and astronomers since they were first postulated in relativistic form a century ago by Karl Schwarzschild. Observations have demonstrated that these bizarre objects really do exist. And on a grand scale, too: not only have we found black holes with masses comparable to stars, but supermassive black holes, a million or even a billion times more massive than the Sun, have also been found at the centres of many galaxies. These black holes also seem to “know” about the galaxies

they live in, as their properties are closely correlated with those of the surrounding galaxy, with more massive black holes being found in more massive galaxies.

Will studies of the supermassive black hole at the centre of the Milky Way reveal the nature of these objects? Do theories of gravitation and general relativity as we know them hold near a black hole's horizon? How do supermassive black holes grow? And what is their role in the formation of galaxies?

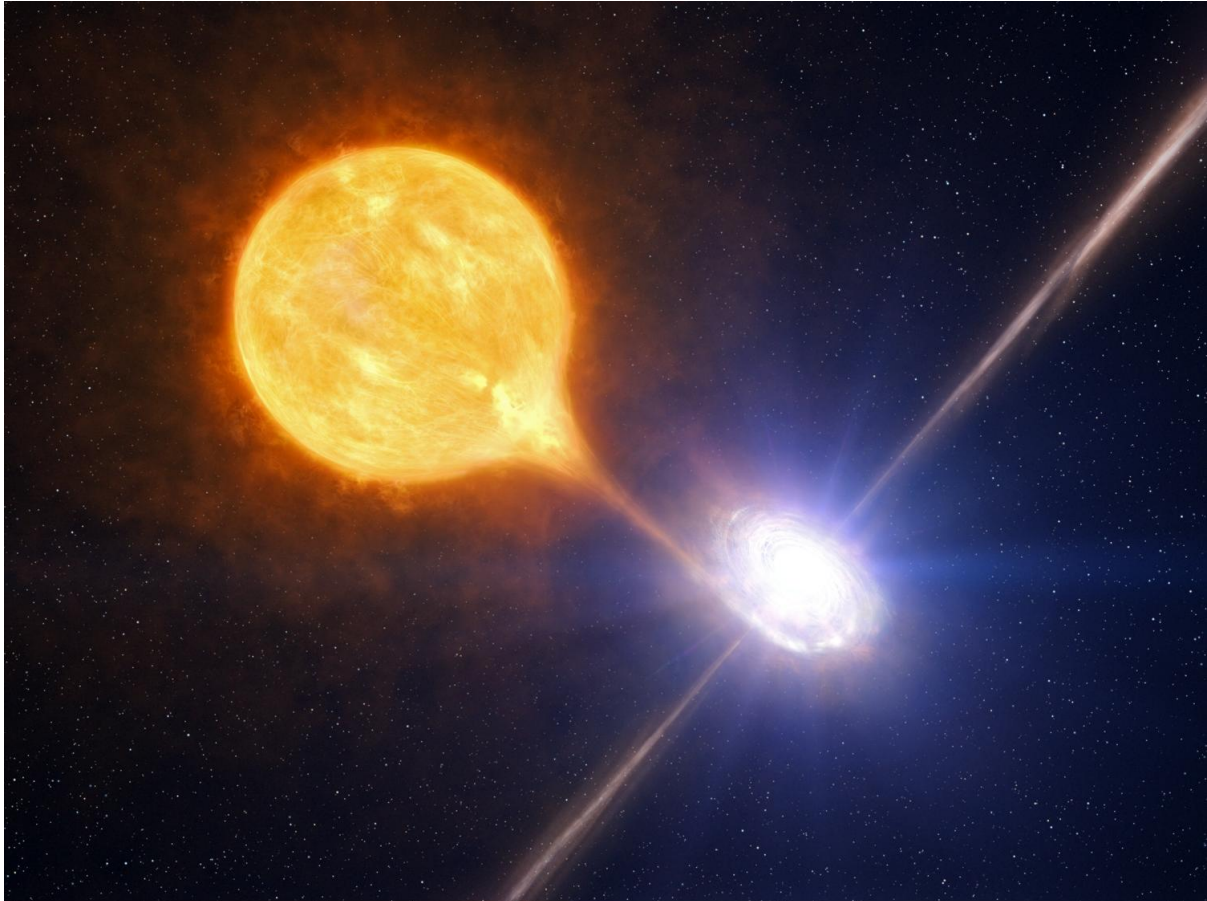

Figure 1.2. An artist's conception of a neutron star, collapsed to a black hole, accreting and ejecting material from its red giant companion.

1.2.2.4 STARS: DON'T WE KNOW ALL THERE IS TO KNOW?

Stars are the nuclear furnaces of the Universe in which chemical elements, including the building blocks of life, are synthesised and recycled: without stars there would be no life. Accordingly, stellar astrophysics has long been a core activity for astronomers. But much remains to be understood. With higher angular resolution and greater sensitivity astronomers will be able to observe the faintest, least massive stars, allowing us to close the current huge gap in our knowledge concerning star and planet formation.

Nucleocosmochronometry — the carbon-dating method as applied to stars — will become possible for stars right across the Milky Way, allowing us to study galactic prehistory by dating the very first stars. And some of the brightest stellar phenomena, including the violent deaths of stars in supernovae and gamma-ray bursts, will be traced out to very large distances, offering a direct map of the star formation history throughout the Universe.

What are the details of star formation, and how does this process connect with the formation of planets? When did the first stars form? What triggers the most energetic events that we know of in the Universe, the deaths of stars in gamma-ray bursts?

1.2.2.5 GALAXIES: HOW DO “ISLAND UNIVERSES” FORM?

The term “island universes” was introduced in 1755 by Immanuel Kant and used at the beginning of the 20th century to define spiral nebulae as independent galaxies outside the Milky Way. Trying to understand galaxy formation and evolution has become one of the most active fields of astronomical research over the last few decades, as large telescopes have reached out beyond the Milky Way. Yet, even nearby giant galaxies have remained diffuse nebulae that cannot be resolved into individual stars. The unique angular resolution of the E-ELT will revolutionise this field by allowing us to observe individual stars in galaxies out to distances of tens of millions of light-years. Even at greater distances, we will be able to make the kind of observations of the structure of galaxies and the motions of their constituent stars that previously have only been possible in the nearby Universe: by taking advantage of the finite speed of light, we can peer back in time to see how and when galaxies were assembled.

What kinds of stars are galaxies made of? How many generations of stars do galaxies host and when did they form? What is the star formation history of the Universe? When and how did galaxies as we see them today form? How did galaxies evolve through time?



Figure 1.3. Centaurus A, 11 million light-years from the Milky Way, is our nearest giant galaxy collision.

1.2.2.6 THE DARK AGES: CAN WE OBSERVE THE EARLIEST EPOCH OF THE UNIVERSE?

For the first 400 000 years after the Big Bang, the Universe was so dense and hot that light and matter were closely coupled. Once the Universe had expanded and cooled sufficiently, electrons and protons could recombine to form the simplest element, neutral hydrogen, and photons could decouple from matter: the Universe became transparent. Only then could the first stars form and start to become organised into larger structures. The E-ELT will allow scientists to look all the way back to these earliest times — prior to the formation of the first stars and hence dubbed the Dark Ages — to see how this first phase of astrophysical evolution began.

What was the nature of the first stars? When did the first galaxies assemble and what were their properties? When did galaxies assemble into larger-scale structures, shaping the distribution of matter as we see it today?

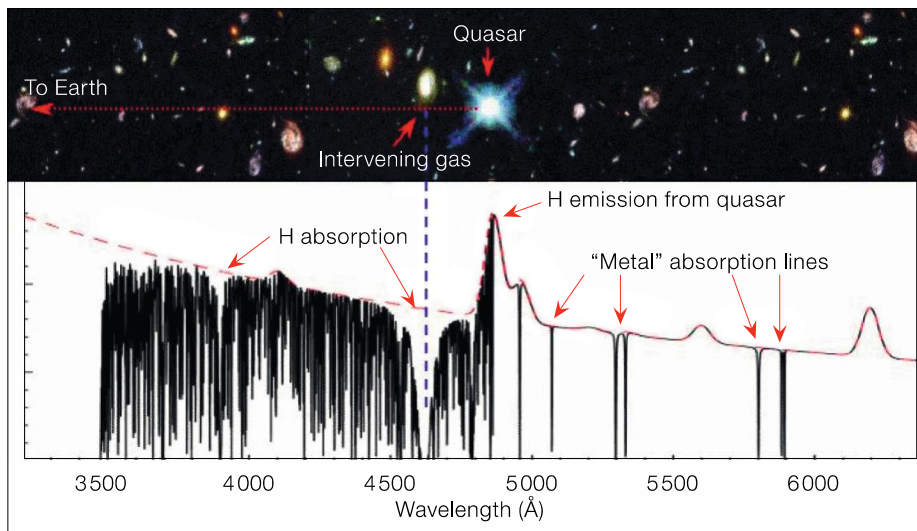

Figure 1.4. The light of distant quasars is absorbed by a variety of components of the Universe on its way to Earth.

The above illustrations merely hint at the science that the E-ELT will carry out, but they give a flavour of the range of problems that it will enable us to tackle, from the origins of the laws of physics to the prevalence of life in the Universe. It will allow scientists to address some of the most fundamental current questions, as well as opening up whole new frontiers of human understanding.

1.2.3 THE ASTROPHYSICAL LANDSCAPE BEYOND 2020

The E-ELT is built to address a very broad astrophysical landscape. Predicting what this will look like between 2020 and 2030 can only be incompletely drafted now. However, planned (i.e., not yet existing) facilities always have some degree of uncertainty attached to them and the exact progress in the relevant scientific fields will also depend on the success of upcoming facilities. The following summary focuses on the facilities and missions that bear most closely on the E-ELT science case.

In 2020, ESO will have operated the VLT for more than two decades. A large fraction of the breakthrough science within the capabilities of the 8–10-metre-class telescopes will have been achieved and consolidation work will dominate. Among the second generation of ESO VLT instruments, MUSE (the wide-field Integral-Field Unit [IFU] optical spectrograph), KMOS (the near-infrared, deployable IFU spectrograph), SPHERE (the planet imager), ESPRESSO (the ultra-stable, high-resolution spectrograph) and potentially one other instrument will have been in use for several years. The La Silla Observatory is likely to be operated at low cost and only for specific large programmes (e.g., similar to the HARPS survey). The survey telescopes, the VLT Survey Telescope (VST) and the 4.1-metre Visible and Infrared Survey Telescope for Astronomy (VISTA), will have finished their first set of large surveys delivering follow-up targets, many too faint for the VLT.

Perhaps more importantly, the Atacama Large Millimetre/submillimeter Array (ALMA) will have been collecting data in full science mode for several years and will have pushed back the frontiers in many scientific areas, predominantly in studies of the high-redshift Universe and star and planet formation.

On the ground, no breakthrough facilities beyond the existing 8–10-metre-class telescopes and potentially a few additional, smaller survey telescopes will be operating, but several game-changing facilities are expected to emerge on the same timescale as the E-ELT: the Large Synoptic Survey Telescope (LSST), as well as the 24-metre Giant Magellan Telescope (GMT) and the 30-metre Thirty Meter Telescope (TMT) optical–near-infrared telescopes. The latter two represent some competition to, as well as complementing, the E-ELT and will be discussed further below. The Square Kilometre Array (SKA) is expected to appear in the decade following the E-ELT and to mainly build on breakthroughs in cosmology.

In space, the James Webb Space Telescope (JWST) might be operating within its five-year minimum lifetime and about to enter its anticipated five-year extension. A dedicated workshop highlighted the strong synergy expected between the JWST and the E-ELT. Current missions such as the Hubble Space Telescope (HST), Spitzer, Herschel, Planck, Kepler will have ended, others might still be flying, but reaching the ends of their lifetimes: Chandra, XMM-Newton, etc. A few new missions such as BepiColombo and Gaia on the European side will be operating; new ones (such as EUCLID, PLATO and LISA) are likely to be launched in the decade following the E-ELT's first light.

Close to the E-ELT science case, many research areas are expected to have progressed significantly by 2020. Thanks to radial velocity surveys (e.g., HARPS, ESPRESSO), but also dedicated imaging surveys (e.g., MEarth, HAT-Net, etc.) and missions such as CoRoT, Kepler and Gaia, the catalogue of exoplanets is likely to have become very extensive. While the discovery of super-Earths in habitable zones is not excluded, it will remain the exception. Neptune- to Jupiter-mass planets will be known in great numbers, enabling progress in planet formation theory. Direct imaging of giant planets distant from their parent stars will be nearly routine. Several atmospheres of (mostly transiting) Neptune- to Jupiter-like planets will have been coarsely studied. With the notable exception of Earth-like planets in habitable zones, which remain to be found, the emphasis in exoplanet research will turn more towards characterisation than further discovery.

In the domain of star formation, ALMA and JWST will follow on from Spitzer, SOFIA and Herschel, and will be making enormous progress. Yet, the picture will remain incomplete as the inner few astronomical units of protoplanetary discs — including the habitable zone and inner rim of the protostellar disc — will await the insights to be generated by the E-ELT's high spatial resolution.

The study of galaxy formation and evolution is the declared strength of the JWST. The JWST will enable the study of mass assembly and chemical evolution of high-redshift galaxies by observing their stars and ionised gas. ALMA will complement these studies by observing the cold gas in these galaxies. Yet again, both facilities will have outstanding sensitivity but lower spatial and spectral resolution, which are the strengths of the E-ELT. While a census and general picture of the formation of the highest redshift galaxies will be in place, a detailed understanding of these objects, which are anticipated to be of small size, will await the E-ELT.

Planned surveys aiming at the better understanding of dark energy will have started (e.g., DES, HETDEX, BigBOSS, EUCLID, WFIRST), complementing the anticipated results of the Planck mission, which is following on from the WMAP mission. The nature of any discovery in this domain is speculative. Ultimately, the direct measurement of the cosmic expansion, only possible with the E-ELT, will allow a fundamentally new approach to measuring the effect of dark energy.

Finally, a number of current and forthcoming space missions will explore our Solar System. The E-ELT promises to be a valuable contributor to understanding the formation of our Solar System, and thus of exoplanets.

1.3 TOWARDS THE E-ELT CONCEPT

The E-ELT programme follows on from the early work by ESO on extremely large telescopes (with a diameter of 100 metres) undertaken in the late 1990s and early this millennium. This work culminated in a design review in November 2005 with concrete recommendations for future work. A period of intense community consultation took place in the first half of 2006 with five working groups comprising a mixture of ESO and community experts that established a starting point for a new baseline design for the telescope based on five reports: on science, site, telescope, instrumentation and adaptive optics.

Initially a 42-metre diameter anastigmatic telescope, incorporating rapidly deformable mirrors in the optical train and providing gravity-invariant foci for instrumentation, was selected as the starting point for the E-ELT. In the second half of 2006, a project office was established and by the end of the year the baseline reference documentation was submitted to the ESO Council as a proposal to move to a detailed design phase. The ancillary information governing this phase B included a management plan, a cost-estimating plan, a resource plan and a schedule. Subsequently this was replaced by the new baseline for a 39-metre diameter telescope with considerably reduced risk and cost.

1.4 COSTING PHILOSOPHY

From the outset ESO strived to establish the technical and managerial feasibility of the project based on technologically demonstrated industrial input. During the design phase, described in Section 1.13 below, the project has followed a consistent philosophy:

- ESO should develop the system-level requirements from the top-level science requirements;
- The design, including the cost and schedule for each subsystem, should be done in competition by industry and reviewed by independent industrial teams;
- The risk associated with high-risk items should be mitigated wherever possible by prototyping, done predominantly in competition by industry.

This has been implemented by using a technique known as Front End Engineering Design (FEED). Multiple competitive FEED studies have been carried out by European industry and reviewed by both the E-ELT project team and separate engineering consultants. All FEED contracts provide as their output, not only the detailed design and all the necessary documentation to put that design out to tender, but also binding cost and schedule estimates backed by firm fixed-price offers to construct. As such the FEED offers are only one (ESO) signature away from being fully implemented contracts. They contain profit and the vendor's margin in order to complete the work for a firm fixed price, to an agreed schedule and with penalty clauses for late delivery. The final contracts will of course be the result of a new round of competitive procurement across the Member States of ESO. However this approach results in a well-qualified design with a very robust cost and schedule estimate. Of course, since these are real contract offers, they must be interpreted as such when assessing the cost and schedule risk of the project.

In parallel with the industrial studies that form the basis for the telescope design, ESO has engaged the astronomical community in the Member States for the development of an instrumentation package that matches the telescope and delivers on the science drivers for the project. Consortia of external institutes, based on initial guidelines from ESO, carried out the instrumentation studies. Eleven different concepts were considered, with over 40 institutes participating in the work. All design concepts were formally submitted by the end of 2010 and subsequently reviewed. Detailed manpower, schedule and cost estimates have been established at the phase A level.

Oversight and guidance to the project have been provided through a variety of committees drawn from the astronomical community at large. The Science Working Group (SWG) worked directly with the project scientist to develop design reference cases and to provide feedback on the capabilities of the telescope and instrumentation as these evolved during the design phase. The Site Selection Advisory Committee (SSAC) received input from the project and advised the Director General. The ELT Science & Engineering (ESE) subcommittee of the ESO Scientific and Technical Committee (STC), with membership overlap with the SSAC and the SWG, followed all aspects of the project and advised the STC and, in turn, the Director General and Council. Finally, the ELT Standing Review Committee (ESRC) reviewed high-level strategic and managerial aspects of the project and provided direct input to Council. Regular updates of the project progress were made to the ESO Finance Committee (FC).

External industrial consultancy was sought by the project for reviews of design and schedule/cost for major subsystems. Astronomers and engineers from ESO and external institutes reviewed the instrumentation reports. The SWG, ESE and STC were involved in this process at all times.

1.5 THE COST OF THE E-ELT

The cost to construct and commission the E-ELT is 1083 M€* including contingency, ESO staff costs and instrumentation.

* ESO's budget is indexed every year to compensate for inflation; therefore all costs in this document are in 2012 euros.

The budget for the telescope (including the dome, optics, main structure, all site civil works, ESO staff costs etc., but without contingency and instrumentation) is 883 M€. Of this 473 M€ (53%) is in firm fixed-price FEED offers.

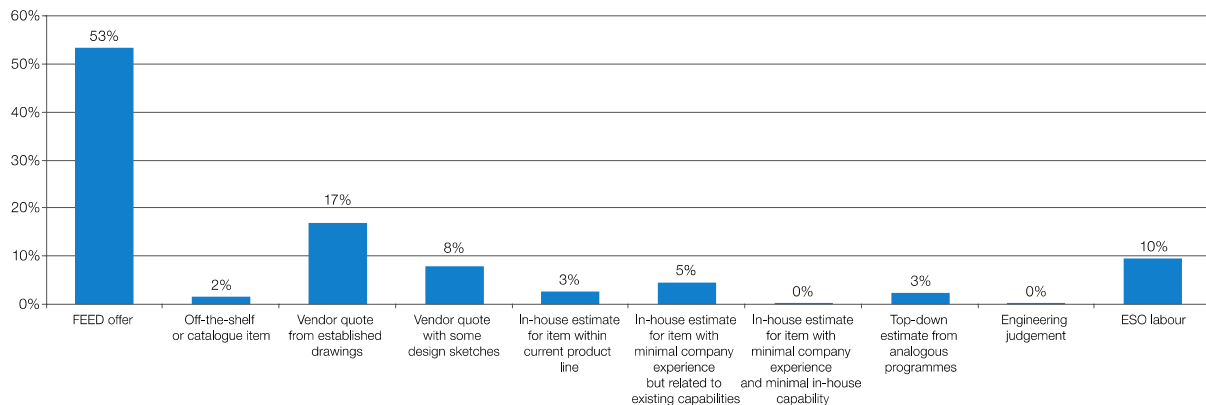

Figure 1.5. The distribution of the basis of estimate of the costs of the E-ELT excluding instrumentation and contingency. 53% is in firm fixed-price FEED offers.

1.6 THE SCHEDULE OF THE E-ELT

Assuming a January 2012 start, the E-ELT programme will take approximately 11 years to execute. Key major milestones are:

- Dome acceptance — March 2017;
- Main structure acceptance — March 2020;
- Technical first light — December 2021;
- Instruments 1 and 2 first light — June 2022;
- Start of observatory operations — October 2022.

1.7 CONTINGENCY

1.7.1 TELESCOPE

The E-ELT budget carries a formal 100 M€ allocation of contingency to cover the risk of building everything except the instrumentation. This budget has been checked in two different ways:

- By comparing with the cost to complete and the FEED offers;
- Bottom-up, by looking at the uncertainty of each element of the Work Breakdown Structure (WBS).

1.7.1.1 CONTINGENCY COMPARED TO THE COST TO COMPLETE AND FEED OFFERS

Because the FEED offers are firm fixed-price contract offers, it is informative to calculate the uncommitted budget if all the FEEDs were to be executed. In this case 473 M€ of the project would immediately be under contract and the 100 M€ of contingency would be 24% of the uncommitted cost to completion. In reality the FEEDs will be competed for again, but the cross-check on the contingency level is reassuring.

1.7.1.2 CONTINGENCY BY LOOKING AT THE UNCERTAINTY OF EACH ELEMENT OF THE WBS

For the FEEDs, contingency is needed to cover the cost of change orders throughout the life of the contract. This is conservatively estimated to be 5%, although ESO's experience of change orders on large contracts is considerably better than this. The contingency required to cover the uncertainties in the remaining 47% of the budget is of course higher and has been estimated using the standard methodology used for ALMA (which is based on the method used in the US Department of Energy and by the National

Science Foundation [NSF] for large projects). Using this approach, the total bottom-up contingency requirement is 86 M€, which again compares favourably with the 100 M€ available.

1.7.2 INSTRUMENTATION

The situation with the instrumentation is very simple. The instrumentation WBS has a ring-fenced budget of 100 M€. This is the construction component of what will be an ongoing instrumentation line of approximately 9 M€ per year. Based on the current cost estimates, the 100 M€ is sufficient to fund the first four instruments, ESO's management of the instrumentation programme and to carry out enabling technology Research and Development (R&D). However, if the cost of the instruments varies as the designs mature (they are only at phase A, which is beyond conceptual design, but not yet at preliminary design level), then the *scope* of what can be delivered within the 100 M€ will be adjusted. The balance of the instrumentation roadmap will be executed from the continuing instrumentation line which starts to ramp up in 2019.

1.8 THE CONSTRUCTION REVIEW AND THE DELTA PHASE B

A technical review in the second half of 2010 found the 42-metre concept to be technically sound and the cost estimates reliable. Concern was expressed regarding the ambitious schedule for such a complex telescope and the recommendation made that the ESO management be prepared for a two–three year extension of the eight-year schedule.

Following phase B, the project has undertaken a series of risk mitigation and cost reduction activities. The project and the technical review concurred that the most challenging areas of the project were the timely completion of the primary mirror segments, the manufacturing of the secondary unit and dealing with the high sensitivity of the telescope to wind loading.

A modified design was adopted by the project in 2010 establishing a 39-metre alternate, which has become the baseline design. The resulting telescope is smaller but also easier to build, faster to erect and more manageable in every aspect. The changes made to the design have been subjected to external industrial review. Without going into the detail that is presented in the rest of this document it is important in this introduction to establish why the smaller E-ELT is a substantially better telescope, other than its manifest increased likelihood of being built, if scientifically somewhat less capable, than the 42-metre version.

The 39-metre telescope has a smaller and faster primary mirror. The reduction in the total number of segments is of order 20%. The fractional cost reduction is smaller than the reduction in telescope size as the non-recurring expenditures account for almost 50% of the total cost of the primary. However, the reduction in schedule risk is significant. The faster and smaller primary mirror allows the design to be optimised for a secondary mirror below 4.2 metres. This critical change permits a realistic diversity of supply in the procurement of the secondary unit. Moreover, the polishing of the convex mirror would only require a single matrix, thereby reducing the complexity and schedule of procuring the test setup. The mechanical safety of the unit under earthquake loading would also be easier to achieve. The other units of the telescope largely scale with the diameter and become proportionally easier to construct. A large benefit of the redesign is the reduction of telescope length and width, thereby reducing the dome volume and the exposure of the telescope to wind disturbances.

1.9 THE COST REVIEW

The cost of the E-ELT, including the contingency and the construction schedule, was subjected to an in-depth external review in September 2011. The Cost Review Committee concluded that the E-ELT project's baseline cost, contingency and schedule planning is ready for the project to proceed to the construction phase.

The committee strongly endorsed the approach of FEED contracts as a way of reducing the cost risk on the project — whereby qualified companies have been paid to perform design studies, at the end of

which they provide a contractually binding offer that is one customer signature away from an executed firm fixed-price contract.

1.10 39-METRE TELESCOPE CONCEPT

The optical design of the telescope is that of a three-mirror anastigmat used within a small field about its axis. Two folding flats are used to extract the beam to a Nasmyth focus. The $f/0.88$ elliptical primary mirror (M1, conic -0.996) has a diameter of approximately 39 metres and an 11-metre central obstruction. The 4.1-metre secondary mirror (M2) is convex and returns the beam, through a hole in the quaternary mirror (M4), to the 3.7-metre mildly aspheric concave tertiary mirror (M3) located at the vertex of the primary. The beam is reflected to the 2.4-metre quaternary flat adaptive mirror that is inclined at 7.7 degrees to the beam direction. The fifth mirror (M5) in the train is flat, elliptical in contour (2.6 metres \times 2.1 metres), defines the altitude axis of the telescope, and steers the beam towards the Nasmyth focus. The output beam at $f/17.5$ is very nearly diffraction-limited over the entire ten-arcminute field of view.

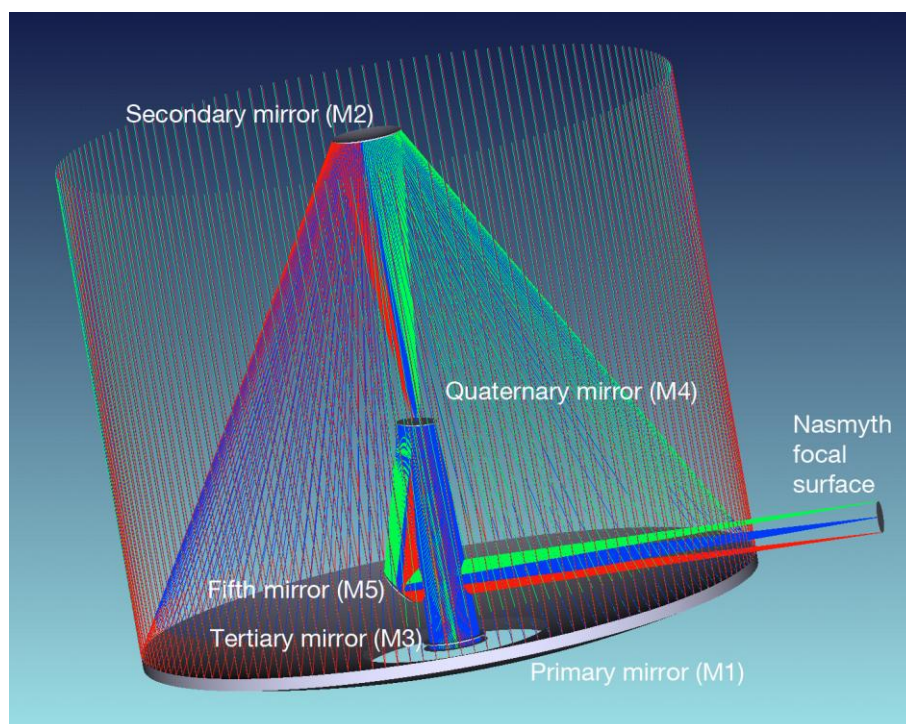

Figure 1.6. Optical layout for the Nasmyth configuration of the E-ELT.

The $f/17.5$ beam can be redirected through relay optics to a coudé focus provided within the telescope foundations at the ground level.

The optics are mounted on an altitude–azimuth telescope main structure that uses the rocking-chair concept with two massive cradles for the elevation motions and two major azimuth tracks. The structure weighs approximately 3000 tonnes. In the central obstruction of the primary a 10-metre-tall tower supports the quaternary and M5 mirrors.

1.11 THE INSTRUMENTATION PLAN

The instrumentation plan for the E-ELT follows on from the 11 design studies developed during the period 2007–2010. The design studies provided an excellent pool of instruments that addressed the broad spectrum of capabilities necessary to attack the E-ELT science goals.

The instrumentation plan is motivated and bound by a wish to deploy cutting-edge instrumentation on the telescope as early as possible without blocking early scientific access to the telescope by excessive commissioning and debugging.

Two instrument concepts have been selected for the first light complement of the telescope: a high spatial resolution multi-conjugate adaptive-optics-assisted camera/spectrograph and an adaptive-optics-assisted integral field spectrograph. These instruments will be mounted on the Nasmyth foci of the telescope. An instrumentation roadmap has been produced that identifies instruments three through five plus the pivotal planetary camera/spectrograph and identifies the key decision points in their construction. The instruments to be mounted on the telescope after first light will start their design and prototyping activities during the period of construction.

The operations budget for the observatory includes of order 20 M€ per annum for investments in new facilities for the E-ELT, of which some 9 M€ per annum is for an ambitious instrumentation programme.

1.12 THE MANAGEMENT PLAN

The management of the E-ELT design project is geared to evolve naturally into the construction project. With this in mind the project office is structured to lead the core decision and control areas of the project while sourcing almost all the manpower resources necessary to follow the contracts and any developments from the matrixed and service divisions of ESO.

Such a lean project office does not carry excessive overheads and provides the ESO management with the flexibility to prioritise activities without an increase in personnel. The E-ELT project will be executed from within the Directorate of Programmes by a dedicated E-ELT Division.

Led by a project manager reporting to the Director of Programmes and with direct access to the Director General, the E-ELT has a project controller, a project scientist, a project engineer, a systems scientist and a systems engineer following the different aspects of the activities and lead engineers in the areas of dome and main structure, optomechanics, control, civil/infrastructure, operations and instrumentation.

Cost and schedule control follows the cost-to-completion and full-cost accounting principles that have guided the VLT and ALMA projects.

Project reporting follows the norms that ESO has established for all significant activities with a biannual report to the Finance Committee and Council.

1.13 DESIGN PROCESS

During phase B, the project initiated a top-down process using the input top-level requirements from the project scientist. In parallel, it launched industrial studies based on requirements extracted from the baseline reference design established at the beginning of the phase B. ESO engineers and scientists form a knowledge base that has a good understanding of telescopes and the assembled team was heavily involved in the VLT. The preliminary design requirements of subsystems were established and documented very early and industrial contracts were launched very soon after the start of phase B.

The subsystem breakdown has been largely conventional, relying on the VLT and other telescope experience within ESO. Five major areas were considered: dome and main structure; optomechanics; infrastructure and site; control system and systems engineering. The project structured its management according to this breakdown, with lead engineers in each area. The detailed work breakdown structure followed product lines, in part avoiding allocation of resources in areas without direct output into the E-ELT project. For each subsystem, three stages of design have been considered.

Phase A design has been conceptual. The functionality of the system was shown, potential solutions were established and volume/weight envelopes set up. This was considered the minimum level of design necessary to advance from phase A to phase B.

Phase B1 design was a preliminary level design of the subsystem undertaken by an industrial partner. It was based on requirements generated by the phase A concepts. A phase B1 design shows the major components of the system and demonstrates, by analysis, that performance can be met. Mass and volume budgets were established. Interfaces to other subsystems were established and plausible cost estimates from industry evaluated. The phase B1 design output includes a thorough revision of the requirements and the technical specification for a next stage of the design.

Phase B2 design stage, referred to as the Front End Engineering Design, is a detailed design stage. FEED studies were undertaken by industry based on the requirements determined by the earlier design stages. FEED detailed design output is considered to be sufficient to tender for construction contracts. Construction will include some degree of final design work to move from the FEED level to shop drawings.

The phase B activities have delivered phase B2/FEED level designs for most of the critical subsystems.

The top-down approach, started in parallel with the design activities, has been coordinated by systems engineering.

In moving from the 42-metre to the 39-metre design, the project has concentrated its resources on risk mitigation and cost reduction elements. As is described below, the dome, main structure, secondary and quaternary mirrors have been the focus of the extended phase B. Delta-FEED contracts or updates to designs have been undertaken during this period, resulting in a revised overall design. A major task has been to revise all interfaces based on the 39-metre baseline.

1.13.1 PHASE B INDUSTRIAL CONTRACTUAL ACTIVITIES

As a preamble, all contracting at ESO is undertaken through the procurement department and, as a norm, all work is tendered for. With very few exceptions, no work is directly sourced to a particular supplier. The procurement of the design work during the phases A and B has followed these rules. There is no binding commitment between ESO and any of the suppliers of design activity for further procurement. With a few exceptions, allowed within the procurement rules, ESO owns the intellectual property of the designs and every effort has been made not to commit to designs that are bound to particular suppliers.

During 2007, the E-ELT dome was the subject of two 500 thousand euro (500 k€) preliminary design (B1) contracts, with ARUP (UK) and IDOM (Spain) respectively, delivering a design and cost/schedule estimates for the procurement. A consolidation phase in 2008 followed in which further analysis in covering mechanisms and airflow issues were considered for one of the designs. The technical specification for the dome was updated to take into consideration the input from the preliminary design phase, and two FEED contracts (B2) were awarded in mid-2009 with IDOM (Spain) and EIE/Cimolai (Italy). The two 1.25 M€ FEED contracts are framed in such a way that a detailed design and construction planning as well as detailed cost estimates are provided. Binding offers to construct are also deliverables of these contracts. For the 39-metre design, contracts were placed with the FEED awardees to update the design and schedule/costs.

Wind tunnel and Computational Fluid Dynamics (CFD) analysis is included in the dome contracts. In addition to that work, the project contracted IDOM to evaluate further the interactions of the telescope and dome in the wind tunnel facilities of a subcontractor in the UK. The 39-metre dome has also been evaluated in the wind tunnel in the UK. The CFD results from the preliminary designs was analysed and further elaborated upon by Weatherpark (Austria). Additional analysis of wind tunnel data was undertaken by CIRA (Italy).

The independent review of the requirements and output (including costs) from the 42-metre FEED contractors was contracted to ARUP (UK) and DSL (Canada).

During 2007, the main structure was the subject of two 500 k€ preliminary design (B1) contracts with EIE/Tomelleri (Italy) and MTM (Germany) respectively, delivering a design and cost/schedule estimates for the procurement. During the consolidation phase, the MTM (Germany) design was selected as a baseline and some further work was undertaken to update the design to match the revised interfaces. The revised

preliminary design was used to update the technical specifications of the main structure that were the basis for the tendering and eventual award of a single 1.25 M€ FEED contract to Empresarios Agrupados (EAI, Spain) in mid-2009. A delta phase B contract for 800 k€ was placed with EAI for the update of the design to the 39-metre baseline.

An independent review of the requirements for the main structure and dome and output of the FEEDs (including costs) was contracted to DSL (Canada).

An independent review of the output of the delta FEEDs (including costs) for the dome and main structure was contracted to ARUP (UK).

DSL (Canada) and DEMONT (Italy) were contracted to evaluate the feasibility and scheduling of the construction and to provide possible optimisation scenarios. Analysis of the ESO handling needs was contracted to Solving (Finland), and an option for a total access platform to Bronto Skylift (Finland).

In mid-2007, two FEED-level prototype quaternary adaptive mirror unit contracts were awarded to CILAS/AMOS/Onera (France/Belgium) and ADS/Microgate/Sagem (Italy/France). Although launched as soon as realistically possible after phase B approval, their specifications had been validated through industrial studies undertaken with CILAS, Sagem and ADS/Microgate during phase A. These were 5.2 M€ contracts to include the construction of prototypes and firm fixed offers to build the final production units. As a risk mitigation activity, additional work was contracted with ADS/Microgate/Sagem for the study of the reference body and no-leak cooling options.

Also in 2007, the M5 electromechanical tip-tilt unit was contracted for 1.2 M€ at FEED-level to NTE/CSEM/Sagem (Spain/Switzerland/France). This included the delivery of a scale-one prototype. The contractor has studied a silicon carbide (SiC) mirror in collaboration with Boostec (France) for the M5. In parallel the project has undertaken conceptual design studies with ITT (USA) and Schott (Germany) for the provision of glass mirrors. With support from BCD (Italy) in the area of finite element model generation, a second heavy M5 study has been contracted to NTE/CSEM/Sagem. A small prototyping activity into SiC by Boostec/Sagem is being monitored by ESO as part of our risk mitigation activities.

In early 2008, two 5 M€ contracts were placed with Sagem (France) and Optic Technium (UK), since renamed to Optic Glyndwr, for the provision of seven aspheric prototype segments for the primary mirror. These FEED-level contracts culminated in firm fixed-price offers to build the entire supply of segments needed for the E-ELT. These contracts include test setups and the necessary tooling and process development for the polishing. Three materials were selected for pairs of blanks, Schott Zerodur (Germany), Corning ULE (USA) and LZOS Astrosital (Russia). The seventh blank has been left free to the supplier to select. Optic Glyndwr has selected ClearCeram from Ohara (Japan) while Sagem chose Zerodur from Schott. In parallel the project has issued a contract for a production study for the primary mirror to ITT (USA). Additional risk mitigation contracts have been placed with Laboratoire d'Astrophysique Marseille (LAM) and Tinsley (USA) to stress polish segments.

In 2007, a 150 k€ contract was placed with CESA (Spain), with the Gran Telescopio Canarias (GTC) acting as a subcontractor, to establish a preliminary design of the segment support structure (connection to the main structure and whiffletree). Following this contract, a revision of the specification was made, taking into account the evolution of the design of the main structure and two FEED contracts for 750 k€ each were placed with TNO (Netherlands) and CESA (Spain) each for the design and construction of three segment support systems. The contracts include some handling equipment. These segment supports have been integrated with the polished mirrors at Sagem and influence function tests have been performed.

In mid-2009, two contracts for 150 k€ each were placed with Physik Instrumente (Germany) and CESA (Spain) for the production of three prototype position actuators for the primary mirror units. A further study by Physik Instrumente for mixed capability actuators has been included in the risk mitigation activities. At the same time one 150 k€ contract was placed with microEpsilon (Germany) for the production of a set of edge sensors for the primary mirror segments.

The airflow and cooling requirements for the primary mirror have been analysed under contract by Kirkholm (Denmark).

In 2008, a preliminary design (B1) 500 k€ contract was placed with MT Mechatronics (Germany) for the design of the secondary mirror cell. In parallel, an evaluation of the requirements and potential solutions for the entire secondary unit, including the mirror and polishing, was contracted to Brashear (USA). The outcome of these studies was used to call and award a 1.5 M€ FEED contract for the entire secondary unit (mirror polishing plus cell). This contract was placed with Sagem/MTM (France/Germany) in late 2009 and has been amended to include the 39-metre secondary option. Design and production studies for the secondary mirror blank have been contracted to Schott (Germany) and Corning (USA).

In 2008 two contracts were awarded to AMOS (Belgium), namely the preliminary design of the pre-focal station at 500 k€ and the preliminary design of the tertiary cell at 300 k€. A further study of the pre-focal station has been contracted to the Danish company Kirkholm. Additionally a 40 k€ contract was later awarded to AMOS/Micromega Dynamics (Belgium) to evaluate a prototype pneumatic shape actuator for the M3 unit.

Active Space Technologies (Portugal) have been contracted to deliver a preliminary design of the adaptive optics calibration unit.

In the area of the control system, contracts have been placed with Observatory Sciences Limited (UK) and SciSys (UK) for the evaluation of existing infrastructures, Røvsing (Denmark) and Critical Software (Portugal) for independent software verification and validation plans, Space Systems Finland (Finland) for the evaluation of real-time requirements, the University of Liege (Belgium) for the control algorithms of the primary mirror cell and KN Systèmes (France) for the design of the primary mirror control system. INES (Switzerland) has provided consultancy for the evaluation of the network requirements and control system demands. In addition, a contract with National Instruments (Germany) assisted with the solution of M1 and M4 control.

Alternate laser technologies based on semiconductors have been contracted to ORC (Finland).

For project control support, contracts have been placed with Franklin & Andrews (UK) for an evaluation of the project risk register, Threon (Germany) for support in the area of risk analysis and with ISQ (Portugal) for product assurance services. Specific support has been contracted to USB (Germany) for the configuration item data list generation.

1.14 OPERATIONS

The operations plan for the E-ELT observatory was one of the deliverables of phase B. The plan has been revised to take into account the new telescope baseline, and aims at maximising the synergies between Paranal and Armazones, which will be operated as a single integrated observatory. The plan describes the operational concepts and plans needed to achieve the E-ELT top-level requirements, and covers aspects related to the observatory management, the science, technical, maintenance and logistic operations, the off-site development and support, the upgrade paths, the staffing requirements and the operations budget.

A number of principles inherited from the experience of operating the Paranal Observatory is at the core of the operations concept. The top-level goal is to maximise the scientific productivity of the E-ELT. This is achieved by ensuring an optimal performance level of telescope and instrumentation by extensive use of metrology, as well as of preventive and predictive maintenance, where the most challenging goal will be to perform, within the available day-time hours, all the required maintenance and corrective tasks necessary to have a “ready-to-go” telescope at sunset.

There will be procedures designed to provide a safe, efficient and cost-effective operation of the facility to deliver scientific data of high and consistent quality together with all ancillary data needed for their calibration, and provide opportunities for technical upgrades and development of new instruments and Adaptive Optics (AO) systems over the lifetime of the facility.

The science operations are based on the VLT paradigm and will be fully integrated, both on-site and off-site, between the VLT and the E-ELT. Extensions taking advantage of technological developments (e.g., high bandwidth) will be implemented for the integrated observatory. The observatory will provide modalities of use of the facility adequate to the scientific goals of each project, and for the most part observations will be flexibly scheduled to make the best use of available atmospheric conditions. A calibration plan will be executed by the observatory to guarantee that scientific data can be calibrated up to a well-specified level of accuracy. The calibration plan will be the basis for monitoring the system performance by continuously monitoring selected parameters. All the science data obtained and their related calibrations will be stored in the ESO Science Archive, to ensure the long-term preservation and accessibility of the data to the entire scientific community through appropriate interfaces.

The operations plan identifies all the activities, both short-term (e.g., daily exchange of two newly coated M1 segments) and long-term (e.g., commissioning of new instruments), needed to carry out the above goals. Work plans have been defined for the technical operations, the inspections, the preventive, predictive and corrective maintenance of all subsystems of the observatory. The tracking of problems with the associated generation of work orders will be managed through appropriate software tools (an evolution of the current problem-reporting system and computerised maintenance management system in use at Paranal today).

Bottom-up estimates of the required time and manpower for each activity, based on the Paranal experience, have been used to determine the staffing (in terms of skills and numbers) and the cost of operating the E-ELT.

1.15 CONCLUSION

The E-ELT design phase has delivered a technically viable solution for an extremely large telescope built by industries and academic institutes in the Member States. The cost and engineering of the project has been validated through extensive interaction with industry and, to the extent possible, prototyping activities have bolstered the confidence of industry to be able to deliver the telescope components.

2 THE SCIENCE CASE

The science case of the European Extremely Large Telescope rests on three pillars:

- Contemporary science — the breakthrough science cases that can be envisaged today for a 40-metre-class telescope;
- Synergies — the interplay of the E-ELT with other major facilities operating in the coming decade or in parallel with the E-ELT;
- Discoveries — the hardest to capture, but probably most interesting potential of the E-ELT.

All three aspects have evolved over the last five to ten years and were subject to many discussions and iterations in the astronomical community. They are discussed in turn below.

2.1 CONTEMPORARY SCIENCE

2.1.1 PLANETS AND STARS

2.1.1.1 EXOPLANETS

Are we alone in the Universe? For millennia, this question was not posed or was purely philosophical. Recently, astronomers have started to provide an answer. With the E-ELT, for the first time in history, technology allows us to observe and to characterise exoplanets in habitable zones.

The first exoplanet orbiting a solar-type star (51 Pegasi) was discovered in 1995 by a European team. Since then, over 600 planetary companions with masses ranging from a few Earth to several Jupiter masses have been found. Most exoplanets are detected indirectly by the radial velocity technique, a method that detects planets by the wobble they induce on their parent star as they orbit it. However, such indirect detections only allow us to infer very limited information about the planet itself, and very few direct observations of planets have been made. With the E-ELT, we will be able to obtain direct images of some of these systems, including planets in the habitable zone, where a rocky planet might hold liquid water on its surface.

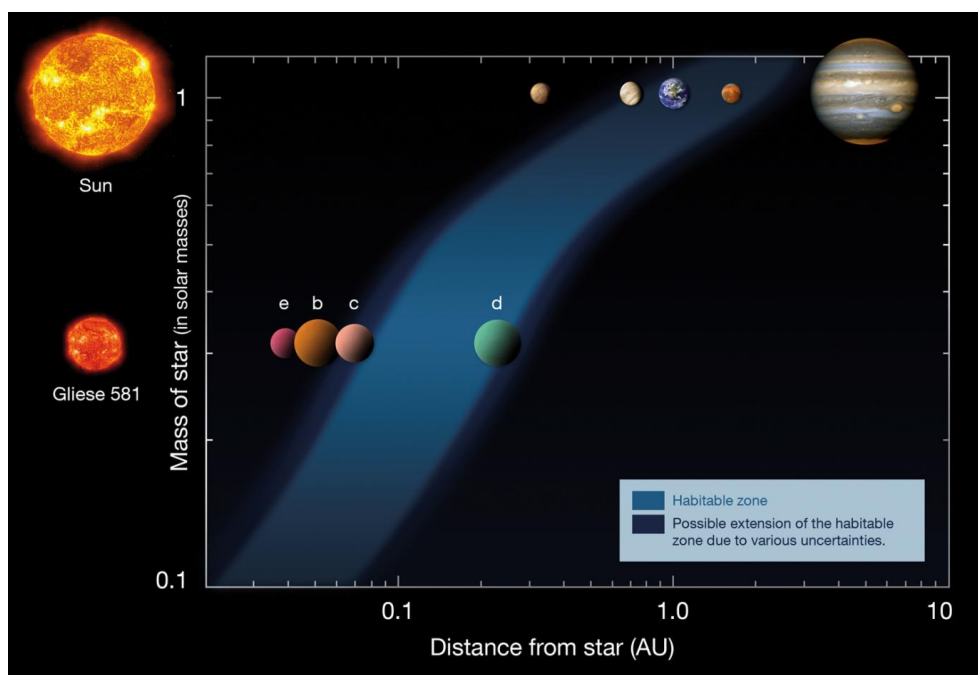

Figure 2.1. The habitable zone, in which liquid water might exist on the surface, varies with stellar mass (i.e., surface temperature). The E-ELT will be able to study Earth twins around Sun-like stars.

2.1.1.1.1 The radial velocity technique — reaching 1 cm s^{-1} accuracy

The radial velocity technique, which measures the induced Doppler shift of features in the spectrum of the parent star, can only find certain kinds of planets. With the current generation of telescopes, this technique is limited both by the precision and the stability of the velocity measurements: current measurements have pushed the limit down to an already impressive $\sim 1 \text{ m s}^{-1}$ precision retained over several years. Unfortunately though, a planet like the Earth orbiting a star like the Sun will only induce a radial velocity of about a tenth this size, which lies at the limit of what can be achieved with even the next generation of instruments on current telescopes. In contrast, ultra-stable spectrographs, combined with the large collecting power of the E-ELT, will achieve measurement precisions of $\sim 1 \text{ cm s}^{-1}$ over periods ranging from minutes to years. For the detection of rocky planets in habitable zones, this precision is needed in order to overcome measurement contamination by seismic oscillations, granulation and magnetic activity of the parent star.

Thus, the E-ELT is essential for finding Earth-like planets in habitable zones, for characterising them and for understanding the properties of their parent stars. This will allow a complete census of rocky Earth- to Neptune-mass planets around nearby stars for the first time, and will provide an understanding of the architecture of planetary systems with low-mass planets. These studies will lead to an understanding of the formation of Solar System twins and will provide an answer to an important part of the fundamental question: just how unique are we?

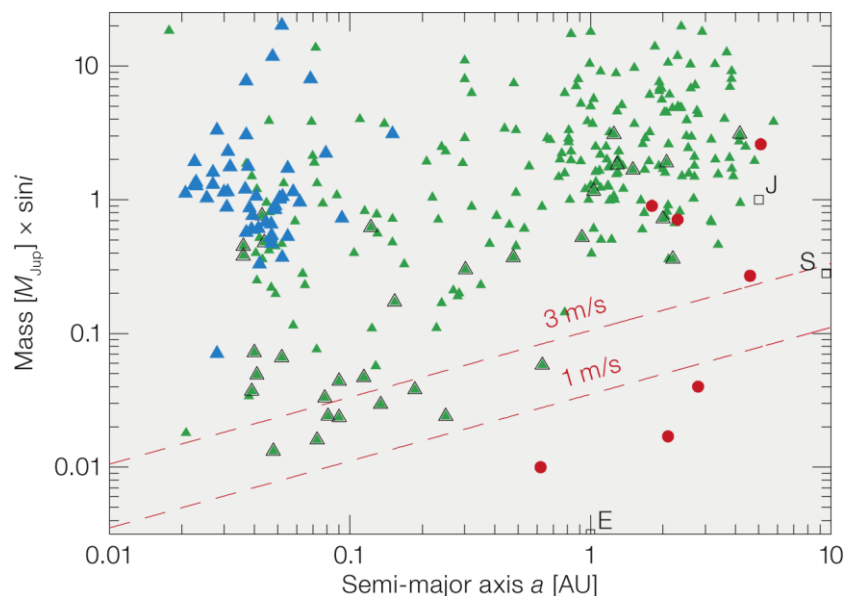

Figure 2.2. Mass plotted against semi-major axis of known exoplanets. The stars currently detected through the radial velocity technique (green triangles) are limited by the accuracy of $\sim 1 \text{ m s}^{-1}$, while the E-ELT will push the limit to $< 10 \text{ cm s}^{-1}$, allowing Earth twins (marked as “E”) to be detected. Credit: Bouchy et al. (2009).

2.1.1.1.2 Direct imaging — approaching 10^{-9} contrast

By 2020, ground- and space-based facilities will have discovered thousands of massive (Neptune- and Jupiter-mass) exoplanets. The E-ELT will start detecting Earth-twin targets in habitable zones using the radial velocity technique described above. By then, the statistical understanding of the properties of the parent stars and the distributions of the masses and orbits of exoplanets will have matured. The next step in exoplanet research will be the physical characterisation of the then known planets.

In order to achieve this, direct light from the planet must be detected and separated from the glare of its parent star. Overcoming this difference in brightness (usually referred to as the contrast) is the main challenge for this type of observation and requires extremely sharp imaging. This capability will be a huge strength of ground-based telescopes. Planet-finder instruments on 8-metre-class telescopes will achieve similar contrasts to the JWST: around 10^{-5} to 10^{-6} at sub-arcsecond distances from the parent stars. The detection of an Earth twin requires contrast of 10^{-9} or better at about 0.1 arcseconds from the star (for the tens of stars within 30 light-years from the Sun). The unprecedented light-gathering power of a 40-metre-class telescope, and the implementation of extreme adaptive optics at the E-ELT are

absolutely crucial for reaching this limit. A planet-finder instrument on the E-ELT will allow scientists not only to study young (self-luminous) and mature giant planets in the Solar Neighbourhood and out to the closest star-forming regions but also to understand the composition and structure of their atmospheres. Around the nearest hundred stars, the E-ELT will enable the first characterisation of Neptune-like and rocky planets located in habitable zones, establishing a new frontier in astrobiology and in our understanding of the evolution of life.

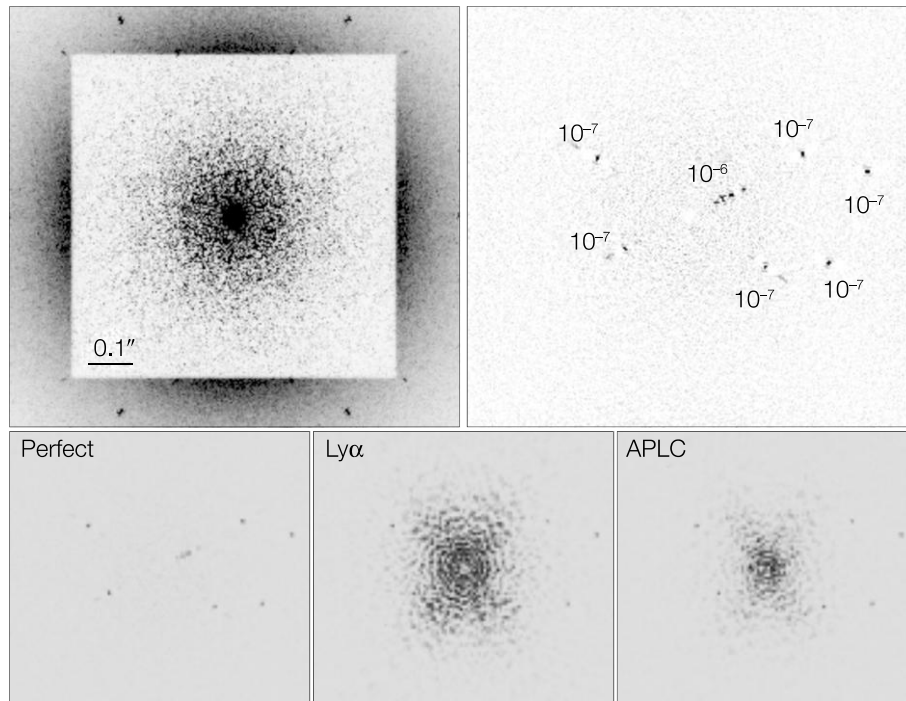

Figure 2.3. Simulation of the direct imaging of exoplanets with the E-ELT. Upper left: Single, one-minute raw exposure at $0.9 \mu\text{m}$ of a star at a distance of 10 parsec (pc) hosting seven planets (with a contrast of 10^{-6} – 10^{-7}), equivalent to up to 10^{-9} in a 10-hour exposure. Upper right: After processing using spectral deconvolution, all seven planets are now clearly visible. Bottom: Simulation of the direct imaging of exoplanets exploring the effects of different coronagraphs — the chromaticity of the coronagraphs is the current limiting factor at small radii.

2.1.1.1.3 Characterising atmospheres

With the E-ELT, the detailed study of the atmospheres of young, massive exoplanets becomes feasible. Indeed, with its unprecedented sensitivity and high spatial resolution at near- and mid-infrared wavelengths, the E-ELT will be able to detect young, self-luminous exoplanets of Jupiter mass. The contrast between star and planet at these wavelengths becomes so advantageous that, for the nearest stars, hydrogen, helium, methane, water ammonia and other molecules can all be detected in low-resolution spectra of the atmospheres of super-Earth planets in habitable zones.

Alternatively, exoplanet atmospheres can be observed during transits in the optical and near-infrared. Ground- and space-based facilities (such as the CoRoT and Kepler missions) are accumulating target stars for which an exoplanet, as seen from Earth, transits in front of its parent star. During these events, which last a few hours every few months or years, spectral features of the exoplanet's atmosphere, back-lit by their parent star, can be seen in the spectrum of the system. Such measurements are barely feasible at present from the ground and space, but lie well within reach of the E-ELT, which will be able to sample several important chemical diagnostic lines.

In the case of rocky planets in the habitable zone, the spectra can be examined for the biomarker molecules that are indicative of biological processes, offering perhaps the best opportunity to make the first detection of extraterrestrial life.

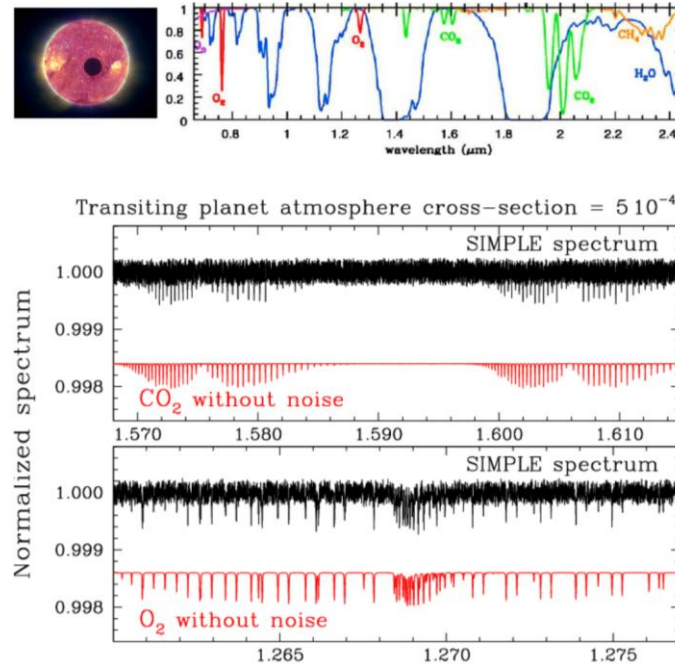

Figure 2.4. Top panel: Near-infrared spectrum of an Earth-like atmosphere. Bottom panel: Expected J-band spectra of the O₂ lines and H-band spectra of CO₂ for a transiting planet with an atmosphere cross-section of 5×10^{-4} . Taken from the science case of the phase A study for the high-resolution near-infrared (NIR) spectrograph.

2.1.1.1.4 Protoplanetary discs and pre-biotic molecules

The observed diversity of properties of exoplanets must be related to the structure and evolution of the discs of protoplanetary material from which they form. A crucial step for our understanding of the origin of life is thus the study of the formation of such protoplanetary discs. The transition from the gas-rich to the gas-poor phases of discs is of particular interest: it is the time when gaseous planets form and rocky planets gradually accrete planetesimals — essentially boulders — onto their cores.

The E-ELT's spatial resolution of a few to tens of milliarcseconds (mas) allows it to probe the inner few astronomical units of these discs out to the distance of the nearest star-forming regions (about 500 light-years), allowing us to explore the regions where Earth-like planets will form for the first time. These data will beautifully complement observations with the new international ALMA submillimetre array that will look at the colder material further out in these systems, together providing a full understanding of protoplanetary disc evolution. Furthermore, the inner discs probed by the E-ELT are those where the key molecules for organic chemistry, such as methane, acetylene, and hydrogen cyanide occur, and more complex pre-biotic molecules are expected to form. Their study will provide a further vital clue in the astrobiology puzzle.

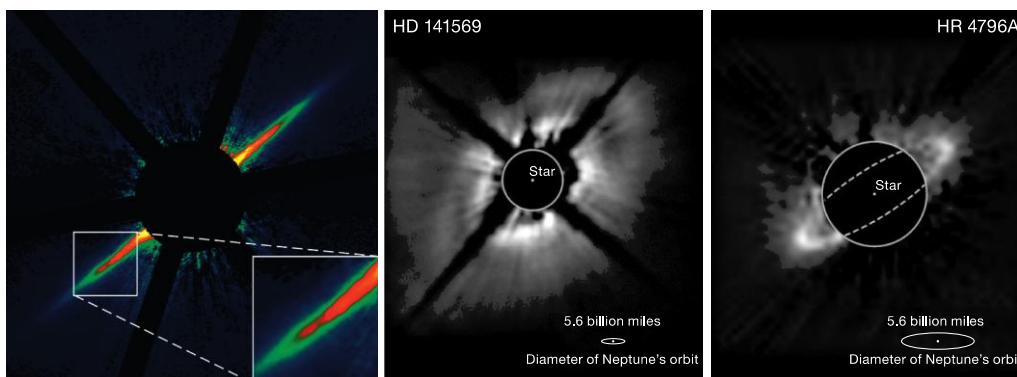

Figure 2.5. Near-infrared scattered-light coronagraphic images of representative circumstellar discs. From left to right: AU Microscopii (Keck image, resolution 0.1 arcseconds, 1 AU at 10 pc; Kalas et al., 2004); HD 141569 (HST image, resolution 0.2 arcseconds, 20 AU at 100 pc; Weinberger et al., 1999); HR 4796A (HST image, resolution 0.2 arcseconds, 15 AU at 70 pc; Schneider et al., 1999).

2.1.1.2 THE BIRTH, LIFE AND DEATH OF STARS

Stars emit nearly all of the visible light that we see in the Universe. The details of their formation process coupled to the formation of protoplanetary discs, their evolution and their (sometimes most energetic) deaths still present some of the most interesting puzzles in astrophysics. The E-ELT is the key facility to answering many of these open fundamental questions.

2.1.1.2.1 *Star formation and the conditions for the formation of planetary systems*

The formation of a star traces a complicated route. The earliest phases of this process during which protostellar cores start to emerge from molecular clouds is often thought to be in the realm of longer wavelength (submillimetre, millimetre, radio) facilities, due to their ability to peer into heavily dust-obscured regions. While this is partly true for present-day optical/near-infrared telescopes, the E-ELT, with its gain in sensitivity and particularly, angular resolution, will be a major player in protostellar/protoplanetary disc research, even in their early stages of evolution.

At mid-infrared wavelengths, the spatial resolution limit of the E-ELT represents, at the distance of the closest star-forming regions (located about 500 light-years away), a few Astronomical Units (AU), i.e. a few times the mean Sun–Earth distance. Thus the E-ELT will be able to probe the innermost regions of the protoplanetary discs and study where rocky planets form. It will also enable a close scrutiny of how a star forms and so make decisive progress in the study of the pre-main-sequence phases.

Many high-mass star-forming regions can be found within a few thousand parsecs from the Sun. At this distance, the E-ELT resolution can probe the very inner regions (tens of AU) of the surrounding accretion discs, allowing us to study in great detail the formation of these luminous stars that so dominate the energy budget and the chemical enrichment of the interstellar medium.

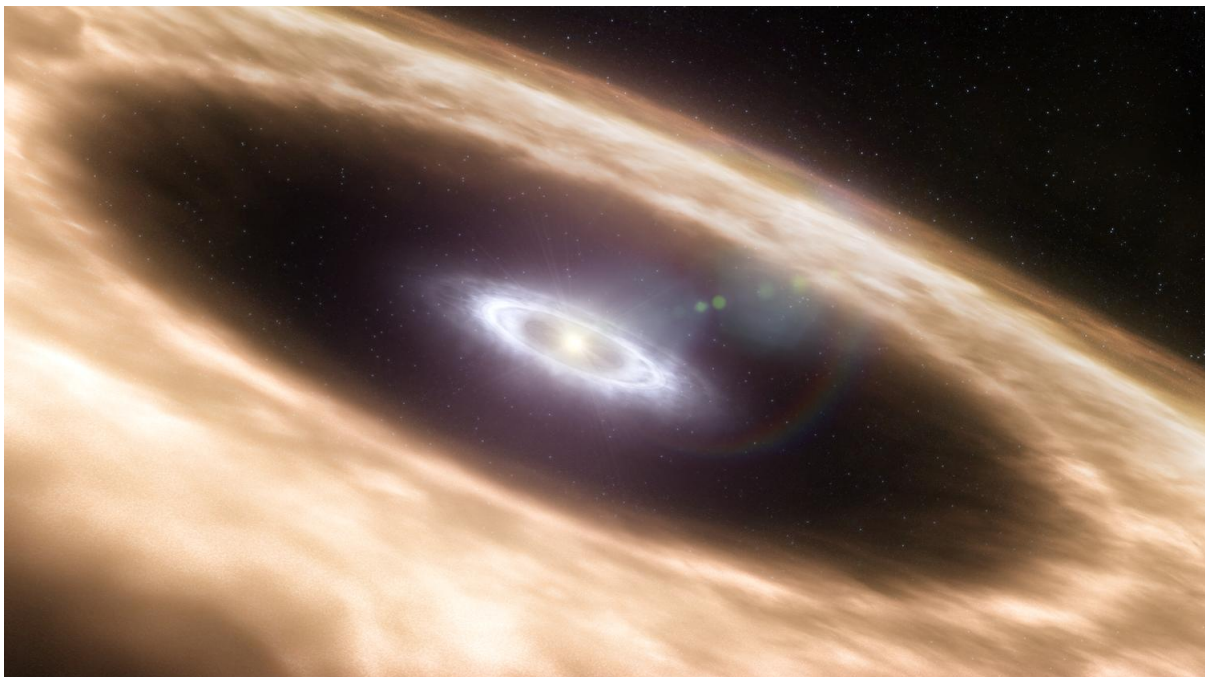

Figure 2.6. With the E-ELT, astronomers will be able to study planet-forming discs in unsurpassed detail at distances larger by a factor of ten than possible today, as illustrated in this artist's impression.

2.1.1.2.2 *Stellar tribulations*

The path taken by a star through its lifecycle varies greatly with its mass. Mass determines not only a star's lifetime and evolution but also its final fate. Understanding the evolution of stars is critical to our understanding of the evolution of the Universe: the continuous recycling process of matter, the energetic processes shaping the interstellar medium, the feedback processes in the evolution of galaxies, and the overall chemical enrichment history of the Universe, all the way to the chemistry enabling life.

High-resolution spectroscopy with the E-ELT from the optical to the infrared will allow unprecedented progress in this field. The E-ELT will allow us to perform nuclear dating (nucleocosmochronometry) on individual stars with ages between 1 and 12 billion years. Current facilities are limited in their collecting power and have performed this measurement on only a handful of stars. The E-ELT will allow measurements of elements such as thorium 232 (half-life 20.3 billion years) and uranium 238 (half-life 6.5 billion years) and their ratios to other elements in hundreds of stars in different regions of the Milky Way. Combined with precise element abundance measurements in stars, and with results from space missions such as Gaia, it will allow us to determine not only the precise age of the major components of our galaxy, but also to date their assembly phases and to describe their chemical evolution. A full understanding of the assembly of the Milky Way is within reach with the E-ELT.

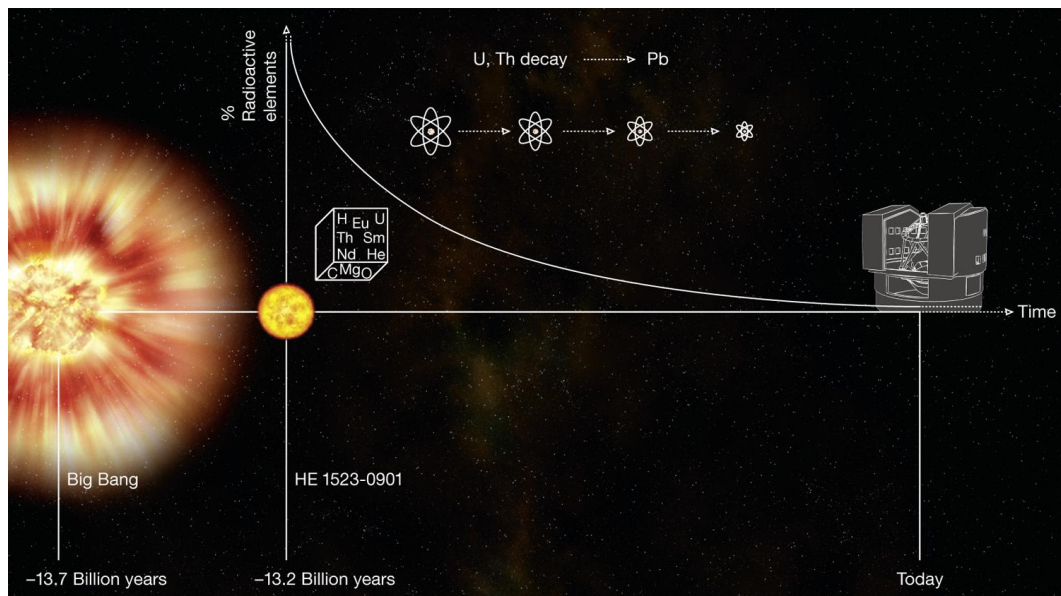

Figure 2.7. Nucleocosmochronometry allows precise measurements of stellar ages, as in the case of the star HE 1523-0901.

At the low-mass end of star formation, we enter the realm of brown dwarfs, which are not massive enough to have started the central nuclear fusion process that powers stars. These objects are particularly interesting as they are expected to have masses and atmospheric properties intermediate between stars and giant planets. Only the E-ELT has the collecting power to reach out in distance and to study in detail the faint brown dwarfs in nearby open star clusters. In addition, the E-ELT has the spatial resolution to study brown dwarfs and planetary-mass objects in so-called ultra-cool binaries, having separations of only a few hundred AU, in nearby environments ranging from young stellar associations (one million years old) to young star clusters (a few hundred million years old). The study of such binary stars allows us to determine precisely the masses of the stars at different evolutionary stages. Thus, the E-ELT will reveal the evolution of sub-stellar mass objects, supporting its work on exoplanets and bringing us closer to a full understanding of the evolution of planets and stars over the full mass spectrum.

2.1.1.2.3 Violent deaths and their consequences

At the high-mass end of the range of stellar properties, the most spectacular events are undoubtedly the deaths in violent explosions of stars of eight or more solar masses. These supernova events seeded the early Universe by ejecting into the interstellar medium carbon, oxygen, iron and other heavy chemical elements. These elements not only critically influenced the formation of stars and galaxies, but were also essential for the later evolution of life. Supernova explosions are amongst the most luminous events in the Universe. As such, they can be used out to great distances as signposts of early evolution.

Gamma-ray bursts have been one of the most enigmatic phenomena in astronomy since their discovery in the 1960s, until they were recently convincingly associated with the formation of stellar-mass black holes and highly collimated supernovae at high redshifts. Gamma-ray bursts are the most energetic explosions observed in the Universe and currently among the competitors for the record holders as the furthest object observed. The collecting power of the E-ELT will allow us to use them as distant light-

houses, shining through billions of years of evolution of the Universe, similar to the way that quasars have previously been used as remote beacons. Gamma-ray bursts have a few advantages: with the E-ELT, they can be detected at redshifts beyond 7, possibly up to 15, taking scientists into the largely unknown epoch of the reionisation of the Universe. Also, as they fade away, they allow us to study the emission components of previously detected absorption line systems. Gamma-ray bursts represent one more route for the E-ELT to study the Dark Ages of the Universe.

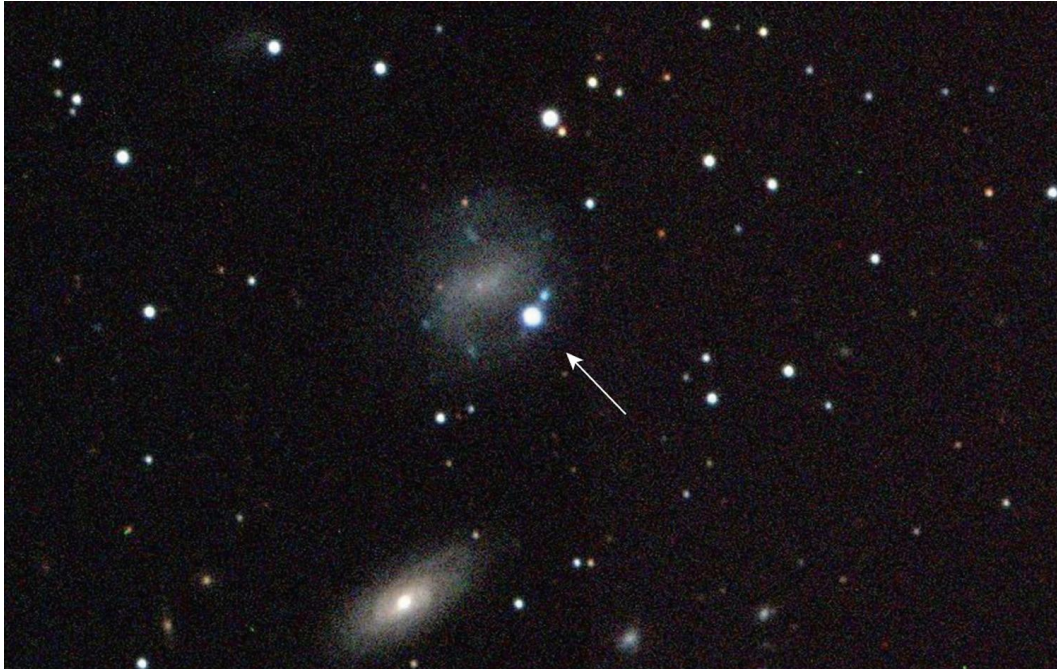

Figure 2.8. This supernova (SN1998bw) has been associated with a gamma-ray burst. The E-ELT will explore such events up to a redshift of 15, i.e. looking back over 13 billion years into the past.

The E-ELT will be able to study supernova explosions in exquisite detail. Similar to gamma-ray bursts, supernova explosions can be used as cosmic probes. Indeed, supernovae provide the most direct evidence to date for the accelerating expansion of the Universe and hence for the existence of a dark energy driving this acceleration. With the current combination of 8-metre-class ground-based telescopes and the Hubble Space Telescope, supernova searches can reach back to only around half the age of the Universe. Infrared spectroscopy with the E-ELT, combined with imaging from the forthcoming James Webb Space Telescope, will allow us to extend the search for supernovae to redshifts beyond four, a lookback time of nearly 90% of the age of the Universe! Supernova studies with the E-ELT will thus critically contribute to the characterisation of the nature of dark energy and the investigation of the cosmic expansion at early epochs.

2.1.2 STARS AND GALAXIES

2.1.2.1 BLACK HOLES

Black holes are some of the most bizarre objects in the Universe, challenging the imaginations of even the most creative scientists. Their environments are places where gravity trumps all other forces, pushing our understanding of physics to the limit. Even more strangely, supermassive black holes seem to play a key role in the formation and evolution of galaxies and structures in the Universe.

2.1.2.1.1 Galactic Centre

Over the last 15 years, an enormous amount of work has gone into improving our understanding of the closest supermassive black hole — Sagittarius A* at the centre of the Milky Way.

Technological progress, in particular in the areas of adaptive optics and high angular resolution with ground-based 8-metre-class telescopes, has allowed impressive progress in understanding supermassive black holes and their surroundings. Key progress was made in proving the very existence of a supermassive black hole at the centre of the Milky Way, in refining our knowledge of how matter falls into black holes, and in identifying gas discs and young stars in the immediate vicinity of the black hole. The Galactic Centre was thus established as the most important laboratory for the study of supermassive black holes and their surroundings.

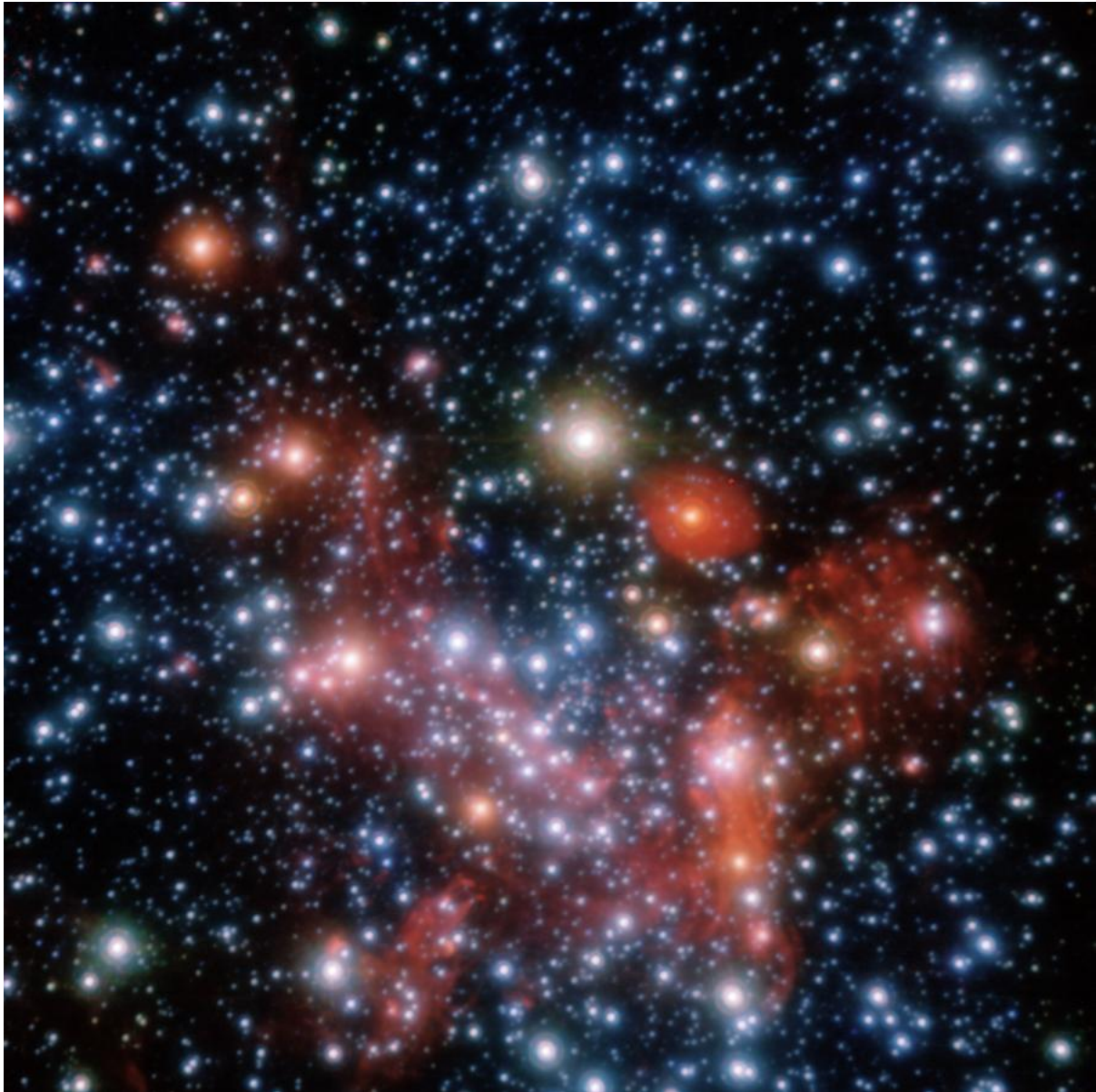

Figure 2.9. The central parts of the Milky Way (field of view $15 \text{ arcseconds} \times 15 \text{ arcseconds}$ as observed with the VLT). By following the motions of the most central stars over more than 16 years, astronomers were able to determine the mass of the supermassive black hole that lurks there. The E-ELT will probe yet closer to the black hole.

But this region's potential for progress in fundamental physics and astrophysics is far from being fully exploited. The Galactic Centre remains the best place to test general relativity directly in a strong gravitational field. The E-ELT will enable extremely accurate measurements of the positions of stars (at the 50–100 microarcsecond level over fields of tens of arcseconds), as well as radial velocity measurements with about 1 km s^{-1} precision, pushing the observations ever closer to the black hole event horizon. Stars can then be discovered at 100 Schwarzschild radii, where their orbital velocities approach a tenth of the speed of light. This is more than ten times closer than can be achieved with the current generation of telescopes. Such stellar probes will allow us to test the predicted relativistic signals of black hole spin and

the gravitational redshift caused by the black hole, and even to detect gravitational wave effects. Further out, the dark matter distribution around the black hole, predicted by cold dark matter cosmologies, can be explored. The distance to the Galactic Centre can be measured to 0.1%, constraining in turn the size and shape of the galactic halo and the Galaxy's local rotation speed to unprecedented levels. Crucial progress in our understanding of the interaction of the black hole with its surroundings will be made. The puzzling stellar cusp around the Galactic Centre, as well as the observed star formation in the vicinity of the black hole will be studied in detail for the first time.

Looking at the Galactic Centre with the collecting power and spatial resolution of the E-ELT will truly allow us to reach new dimensions in our understanding of black hole physics, their surroundings and the extent of the validity of general relativity.

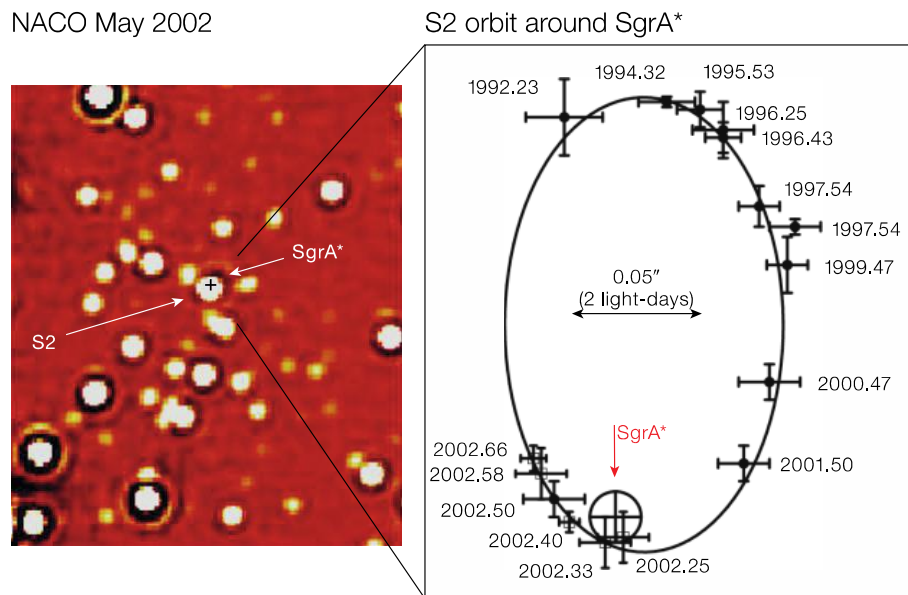

Figure 2.10. Infrared NACO image of an area of ~ 2 arcseconds \times 2 arcseconds, centred on the position of the compact radio source SgrA* at the centre of the Milky Way Galaxy. The angular resolution is about 0.060 arcseconds. In 2002, the star designated "S2" came within 0.015 arcseconds of the radio source. At the distance of the Milky Way Centre, 1 arcsecond on the sky corresponds to 46 light-days.

2.1.2.1.2 Intermediate-mass black holes

Black hole research with the E-ELT will not be limited to the Galactic Centre. An open question awaiting the advent of the E-ELT is the existence and the demographics of intermediate-mass (100–10 000 solar masses) black holes. These black holes represent a currently missing link between stellar-mass black holes and supermassive black holes with the intermediate-mass objects serving as seeds in the early Universe for the formation of the supermassive examples that we see today. They could plausibly form from the first ultra-massive stars or, alternatively, via the same unknown mechanism that forms supermassive black holes. Their existence in the local Universe cannot unambiguously be proven with current observational facilities. To date, only a few detections at the centres of dwarf galaxies and massive star clusters have been reported. Their existence has been inferred either from X-ray and radio emission that is believed to originate from matter falling onto a black hole, or from disturbances in the motions of stars and gas at the centre of these objects. The E-ELT will be able to measure accurately the three-dimensional velocities of stars in these star clusters and dwarf galaxies. This will allow the determination of the masses of the intermediate-mass black holes that are speculated to lie at their cores.

2.1.2.1.3 Supermassive black holes and active galactic nuclei

During the past decade, a correlation between the mass of a galaxy and the mass of its central supermassive black hole has been observed. For these properties to be related, a number of mechanisms must be at work over nine orders of magnitudes in scale, from galaxy environments to the "sphere of influence" of the black hole. The E-ELT will probe scales of less than a few parsecs (~ 10 light-years) in the very central regions of galaxies out to cosmological distances of hundreds of millions of light-years, allowing us to study nuclear clusters and active galactic nuclei in galaxies with unprecedented detail. The

combination of high spatial resolution with spectroscopic capabilities available with the E-ELT will enable us to map the gas motions in the regions immediately around the active nucleus of galaxies and to understand the inflow of material accreted by the central black hole. Furthermore, supermassive black holes will be characterised out to large distances with the E-ELT, allowing us to trace the build up of these central objects in galaxies when the Universe was as young as a quarter of its present age.

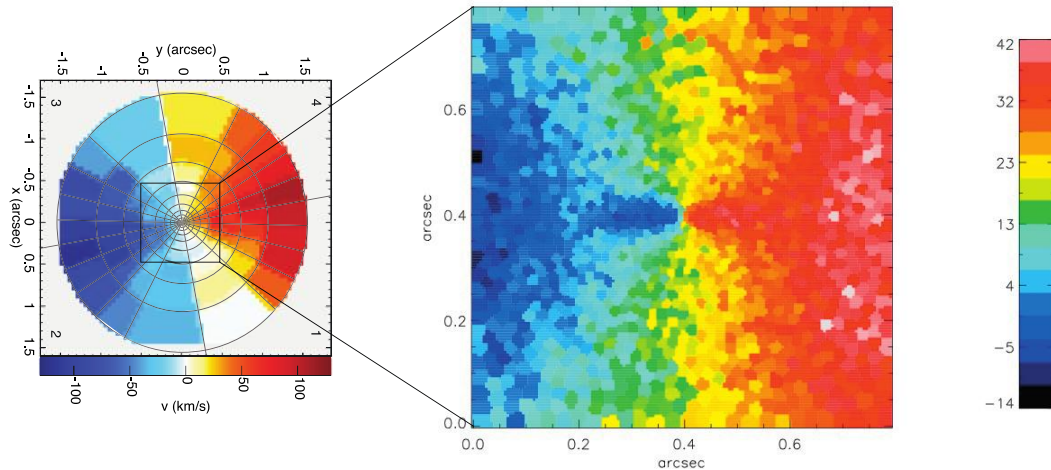

Figure 2.11. Comparison of a VLT observation of the sphere of influence of a supermassive black hole with an E-ELT simulation. Left: Velocity map of the central region of NGC 4486a in the Virgo cluster derived from VLT observations by Nowak et al. (2007), showing the existence of a 10^7 solar-mass black hole at only marginal significance. Right: E-ELT simulation of the same system where the black hole is now detected at 5 sigma.

2.1.2.2 THE STELLAR CONTENT OF GALAXIES

Galaxies are the main building blocks of the visible large-scale structure of the Universe. The galaxies themselves are made up of billions of stars of all ages and chemical compositions. When astronomers study the light of a galaxy, they are observing the diffuse light emitted by all the individual stars in the galaxy. To make significant progress in our understanding of structure formation in the Universe, i.e. of galaxy formation and evolution, many of the individual stars in these distant galaxies need to be analysed. In this regard, the E-ELT is again an unprecedented facility.

The most plausible current theory for galaxy formation is the hierarchical assembly model, in which all galaxies are built up from smaller pieces. This theory has been extensively explored by numerical simulations as a theoretical experiment and tested against the global characteristics of galaxy populations, but not against the detailed properties of individual galaxies. The ultimate test of this model is to compare predictions of the stellar content of galaxies to what we actually see in galaxies of all types: spirals, giant elliptical, irregular and dwarf galaxies.

2.1.2.2.1 Star formation throughout the Universe

The billions of individual stars that make up a galaxy carry information about the formation and subsequent evolution of their host, but only if we can study the stars individually. If we can measure the amounts of the different chemical elements in stars as a tracer of their ages and origins and combine such information with the current motions of these stars, we can begin to unravel the complex formation history of the galaxy. For instance, the first generation of stars contains very low abundances of the heavier elements like iron and oxygen. As supernovae explode and enrich the interstellar medium out of which the next generation of stars forms, subsequent generations will contain more of these elements. By measuring the content of such trace elements in the stars, we can determine how many stars formed where and when and thus extract the star formation history of the galaxy. Current telescopes can only resolve individual stars for the nearest few large galaxies. This has already yielded interesting results, but does not allow us to draw any general conclusions about galaxy formation.

By contrast, the E-ELT will allow the method to be applied to some thousands of galaxies across a more representative slice of the Universe, allowing us to compare the stellar contents of galaxies of all types for the first time and to draw the first general conclusions about their formation histories.

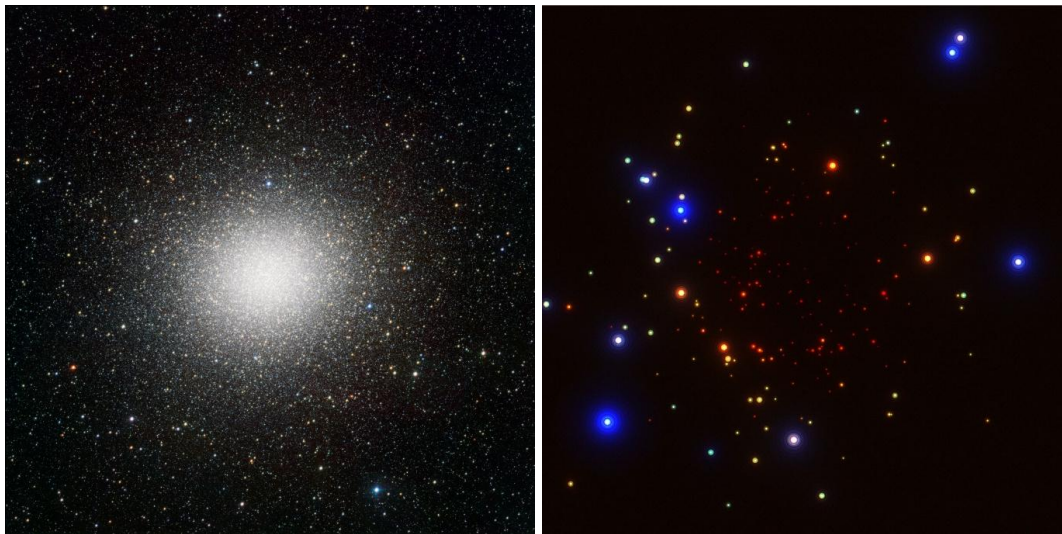

Figure 2.12. Left: The most massive globular cluster in the Milky Way: Omega Centauri, ~ 30 light-years across, potential host of a 10 000 solar-mass black hole to be confirmed with the E-ELT. Right: Simulated mid-infrared image of a massive young star cluster at the distance of the Galactic Centre. The cluster is heavily obscured and reddened by dust, causing up to 200 magnitudes of extinction in the visual. The E-ELT will be able to resolve stars in deeply dust-extincted regions and in other stellar systems out to distances of 55 million light-years.

2.1.2.2.2 Colours and luminosities of individual stars out to nearby galaxy clusters

Pushing out a little further in distance, the nearest galaxy clusters, located at a distance of about 55 million light-years, are prime targets for the E-ELT. These clusters, which contain thousands of galaxies packed in close proximity, are believed to have evolved very differently from the more sparsely distributed field galaxies. Even at these distances, the E-ELT will be able to resolve individual stars and study their basic properties, such as colour and luminosity, to obtain a measure of their ages and heavy element content. Within individual galaxies, it will be possible to see whether the star formation history varies with position, as might be expected if star formation continues in the inner parts of the apparently quiescent galaxies that populate these clusters. Such measurements can then be compared with what we find in the sparser non-cluster environments to see how a galaxy's surroundings affect its star formation history.

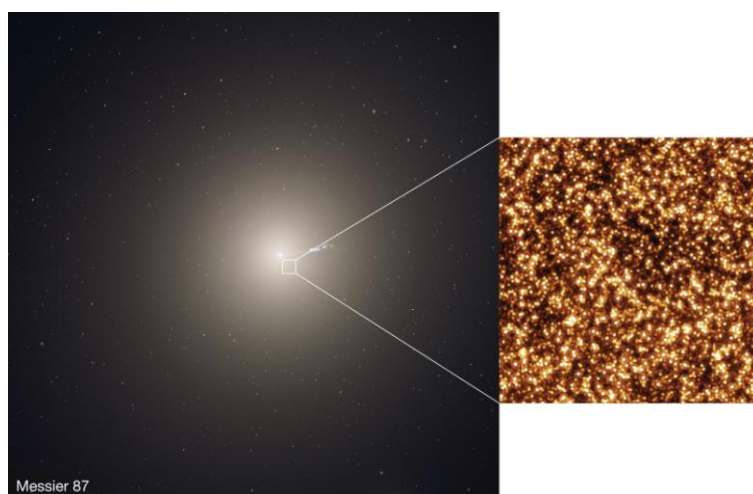

Figure 2.13. This simulated (1 arcsecond \times 1 arcsecond) near-infrared image of a field near the centre of Messier 87, the giant galaxy at the core of the Virgo galaxy cluster, demonstrates that the E-ELT will be able to resolve individual stars even in the dense inner regions of giant elliptical galaxies 55 million light-years away, surpassing the capabilities of the JWST.

2.1.2.2.3 Spatially-resolved spectroscopy of stars and clusters

The chemo-dynamical signature of galaxy evolution is best traced through spatially-resolved spectroscopy of the individual stars. While this domain is inaccessible beyond the Milky Way to the current generation of telescopes, the E-ELT will provide us with precise stellar kinematics measurements of the host galaxy out to distances of ~ 55 million light-years. It will allow us to compute the mass and distribution of dark matter in these systems.

Using, for example, the Ca II triplet, medium-resolution spectroscopy of stellar samples covering the galaxies' different components, e.g., thin disc, thick disc, halo and bulge, will return complete maps of the chemical composition and element abundances and so will test in detail the predictions of galaxy formation and chemical evolution models.

High-resolution spectroscopy will be used to study the chemical composition and kinematics of stars in Local Group dwarf spheroidal galaxies and star clusters to constrain the dark matter content and the presence of multiple stellar populations in these systems. Furthermore, near- and mid-infrared 3D-spectroscopy with the E-ELT will allow us to study deeply embedded young, massive stars in dense Galactic proto-cluster clouds, penetrating as much as 200 magnitudes of visual extinction. The combination of astrometric (50 microarcsecond [μas] on a single image), proper motion ($\sim 1 \text{ mas yr}^{-1}$) and spectroscopic radial velocity ($\sim 1 \text{ kms}^{-1}$) data are crucial for the study of dynamical processes associated with cluster formation. Integrated high-resolution spectroscopy of star clusters ($M \sim 10^6 M_{\odot}$) up to the distance of the Virgo/Fornax galaxy clusters (55–60 million light-years), and low-resolution spectroscopy up to the distance of the Coma cluster (~ 300 million light-years) will enable us to study the kinematics and chemical abundance of these systems which can be used as tracers of star formation in galaxies. With the simultaneous high spatial and spectral resolution of the E-ELT, we will be able to discriminate between different mass functions in these systems thanks to precise velocity profiles ($\sim 1 \text{ kms}^{-1}$) from their inner regions to their outskirts. Precise velocity dispersions beyond the star cluster's core will also be fundamental for testing Newtonian gravitation in low acceleration regimes (10^{-10} ms^{-2}). The Newtonian and the Modified Newtonian Dynamics (MOND) velocity dispersion profiles can indeed differ by 1–2 kms^{-1} according to the models.

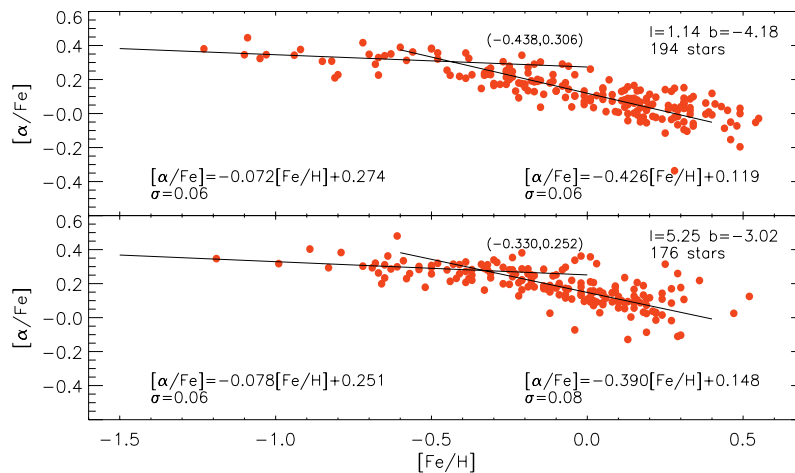

Figure 2.14. Evolution of core-collapse supernova enrichment (traced by the α -element over iron, $[\alpha/\text{Fe}]$, abundance) as a function of chemical enrichment (traced by the iron over hydrogen ratio, $[\text{Fe}/\text{H}]$) for Milky Way bulge stars. Taken from Gonzalez et al. (2011).

2.1.2.2.4 The stellar initial mass function

The study of individual stars in nearby and distant galaxies not only reveals the star formation history of their hosts, but is also crucial to our fundamental understanding of their own formation and evolution. The predominant factor determining the evolution of a star is its initial mass. The initial mass function — IMF, the distribution of the masses of forming stars — is a key ingredient in all interpretations of unresolved stellar populations. However, the relative fraction of low-mass stars in other galaxies, where conditions can be very different from the vicinity of the Sun where we can currently measure it, remains unknown due to the limited abilities of current telescopes to detect low-mass, very faint stars beyond the

Milky Way. With its unprecedented sensitivity, the E-ELT will be able to detect these low-mass stars even in other galaxies.

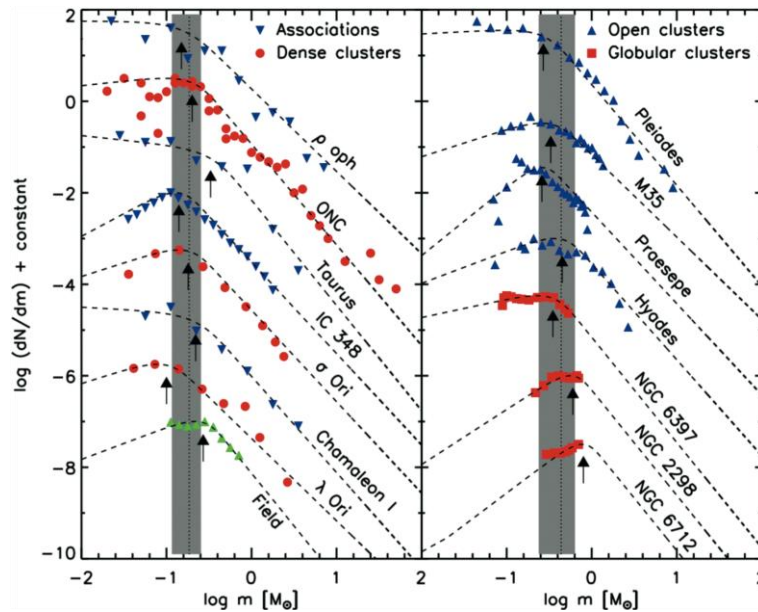

Figure 2.15. Three derived present mass functions for young star-forming regions. The observations are consistent with a single underlying IMF, although the scatter at and below the stellar/sub-stellar boundary clearly calls for further study. Taken from Bastian, Covey & Meyer (2010).

2.1.2.2.5 The intra-cluster stellar populations

Cosmological simulations of structure formation predict that galaxies are dramatically modified by galaxy interactions during the assembly of galaxy clusters, losing a substantial fraction of their stellar mass, which must today exist in the form of intra-cluster stars. Observations now show that there is a substantial intra-cluster stellar population, observed as diffuse intra-cluster light or as individual stars, i.e., planetary nebulae and red giant stars. This light represents up to 10% of the stellar mass in the Virgo galaxy cluster and as much as 50% in rich Abell galaxy clusters. Within a distance of ~ 60 million light-years, the Virgo and Fornax galaxy clusters provide laboratories for studying the effects of different density environments on galaxy evolution and the correlation of intra-cluster light properties with cluster dynamical status. The E-ELT will allow us to study the presence of metallicity gradients and the velocity distribution of the intra-cluster stellar populations, adopting near-infrared imaging and low-to-medium-resolution spectroscopy of red giant branch stars and planetary nebulae.

2.1.2.2.6 Cosmic star formation rate from supernovae

Supernovae are good tracers of the star formation history as they are one of the end products of stellar evolution. Given the short lifetime of their massive progenitor stars ($> 10 M_{\odot}$) and their high luminosity during explosion, they are extremely well suited for tracing the star formation rate of a large fraction of the observable Universe. With the collecting power of E-ELT we will be able to observe and count supernovae out to distances corresponding to a redshift of four (~ 12 billion years lookback time), to probe the global star formation history of the Universe.

The E-ELT will expand the portion of the Universe resolvable into stars by a factor of more than 100. It will allow scientists to obtain accurate knowledge of the present-day stellar populations in galaxies as far out as the nearby galaxy clusters. It will return a comprehensive picture of galaxy formation and evolution through a detailed study of stellar populations in nearby galaxies and provide the most stringent tests to date for current theories of galaxy formation and evolution.

2.1.3 GALAXIES AND COSMOLOGY

2.1.3.1 THE END OF THE DARK AGES — FIRST STARS AND SEEDS OF GALAXIES

What was the nature of the first object to shine through the Universe? How did the gas, dust, heavy elements and stars build up? What caused the re-ionisation of the Universe? Were the first galaxies fundamentally different from present ones? The E-ELT is the key to establishing the physics of the first light-emitting objects in the Universe.

Over the last decade significant progress in determining the processes of galaxy evolution has been made using the combined power of current ground-based telescopes and the HST. The limits of the observable Universe have been pushed to a redshift of 7–8, which corresponds to looking back nearly 13 billion years or 95% of the age of the Universe. The global star formation activity from that epoch to the present day has been estimated and the first insights into the stellar mass assembly history out to a redshift of three (i.e., 11.5 billion years back in time) have been acquired. However, the most uncertain issue in present-day cosmology remains the question of how and when galaxies assembled across cosmic time.

The current cosmological model gives a credible explanation of the formation of structures in the Universe through the hierarchical assembly of dark matter halos. In contrast, very little is known about the physics of formation and evolution of the baryonic component of gas and stars, because the conversion of baryons into stars is a complex and poorly understood process. As a result, all advances in understanding galaxy formation and evolution over the last decade have been essentially empirical, often based on simplified phenomenological models. Cornerstone parameters in this empirical framework are the total and stellar masses of galaxies, together with their physical properties. They include detailed knowledge about the ages and metallicities of the underlying stellar populations, dust extinction, star formation rates and morphological parameters. The study of well-established scaling relations involving a number of these physical parameters, such as those between mass and heavy element abundance, or galaxy morphology and the density of the surrounding environment, are essential for understanding the physical processes that drive galaxy evolution.

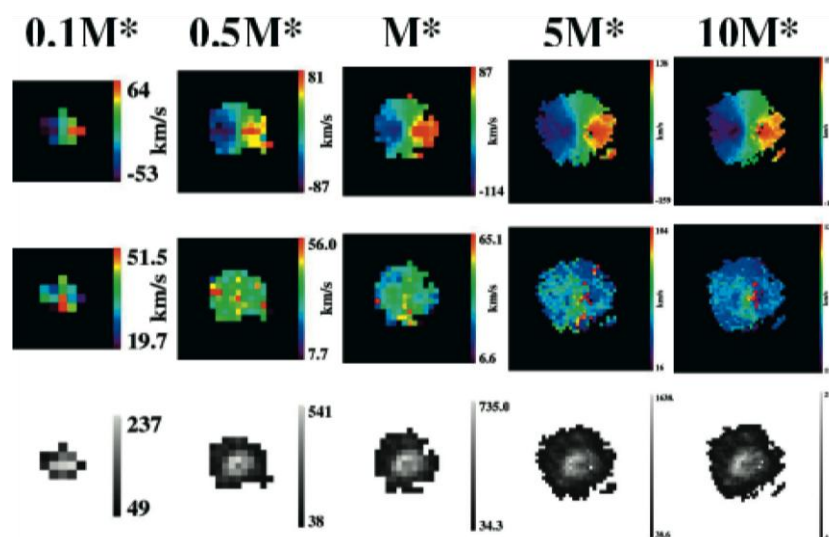

Figure 2.16. Simulated E-ELT observations of the kinematics of rotating disc galaxies at a redshift of 4 (~ 12 billion years lookback time). The velocity maps (blue: approaching stars, red: receding stars) of Milky Way type galaxies (M^) as well as more and less massive cases can be built with the E-ELT, allowing us to distinguish disc galaxies from merging galaxies, even for low-mass systems.*

With the current generation of telescopes, we have been able to study these tell-tale correlations between the properties of galaxies over a wide range of masses in the nearby Universe. However, only the brightest or most massive galaxies have been accessible at redshifts larger than one, and a direct measurement of masses has been almost completely out of reach at redshifts larger than two. Thus, our

ability to explore the evolution and origin of these scaling relations has rapidly reached the limits of current technology telescopes, and will only be advanced in the era of the E-ELT.

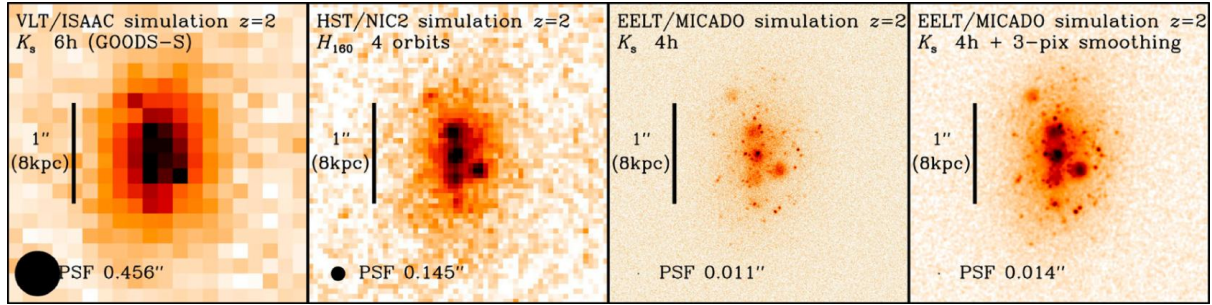

Figure 2.17. Illustration of the gain in spatial resolution when observing a galaxy at $z = 2$ (10 billion years lookback time) with the E-ELT. The E-ELT will be able to resolve such high redshift galaxies and measure structural parameters and scaling relations.

2.1.3.1.1 Observing the epoch of the first stars

High spatial resolution, diffraction-limited imaging and spectroscopy with the E-ELT will provide invaluable information about the morphology, dynamical state and variations in physical parameters across galaxies over large cosmological timescales. With these in hand, our knowledge of galaxy evolution will make a giant leap forward. Detecting the first ultraviolet-emitting sources will push the limits of the observable Universe beyond redshifts of 7–8 and will allow us to probe the era of a few hundred million years right at the end of the Dark Ages: the epoch when the first light-emitting objects, which ionised much of the content of the Universe, switched on.

Questions still to be answered are whether galaxies caused this re-ionisation and whether these galaxies were then similar to, or fundamentally different from, the relatively normal galaxies that we see at somewhat lower redshifts. Direct kinematics of the stars and gas in the first generation of massive galaxies, obtainable with the unprecedented spatial resolution of the E-ELT, will be used to draw a consistent picture of the mass assembly and star formation of galaxies across the entire history of the Universe.

2.1.3.1.2 Peering through the dust

With E-ELT’s enhanced sensitivity in the near-infrared, it will be possible to derive dust extinction maps from intensity ratios of hydrogen emission lines over a variety of redshifts. Star formation rates will be derived from the extinction-corrected emission line luminosities, using suitable diagnostic emission lines. These results will be combined with other indicators coming from multi-wavelength observations to produce a truly definitive measure of the star formation histories of galaxies of different types.

Detailed knowledge of star formation across all cosmic epochs will allow us to explore how the star formation histories of galaxies depend on the environment in which they find themselves. Thus, the migration of the peak efficiency of star formation rate from high to low masses as galaxies evolve, known as the “downsizing effect”, will be studied through the epochs during which the effect is believed to have occurred.

2.1.3.1.3 The intergalactic medium

A key to further progress is a better understanding of the complex interplay between galaxies and the surrounding intergalactic medium. The intergalactic medium provides the reservoir of gas for the continuing infall of fresh material into galaxies. At the same time, it acts as a repository for the gas driven out of galaxies by energetic processes such as active galactic nuclei and supernovae. The combination of these processes is responsible for the regulation of the gas supply that ultimately dictates star formation and black hole growth as well as the chemical and structural evolution of galaxies. Heavy elements play a very important role for most, if not all, aspects of the complex lifecycle of gas in galaxies and the intergalactic medium. Measuring the widths of the absorption lines of triply ionised carbon, C IV, is a powerful tool for studying this lifecycle. However, the intrinsically low column densities of C IV make this cardinal test very difficult with existing telescopes. With the E-ELT we will be able to use this and similar diagnostics to determine the properties of the intergalactic medium around galaxies of different types over a wide

range of cosmic epochs, fully assessing the critical role that it has played in shaping the galaxies that it was feeding.

The E-ELT will directly probe the physical properties of galaxies as a function of their mass and environment for over 95% of the age of the Universe which, for the first time, will cover the entire epoch over which these systems formed. With these additional observational inputs, astronomers will be able to directly determine many of the parameters currently assumed in models of galaxy formation.

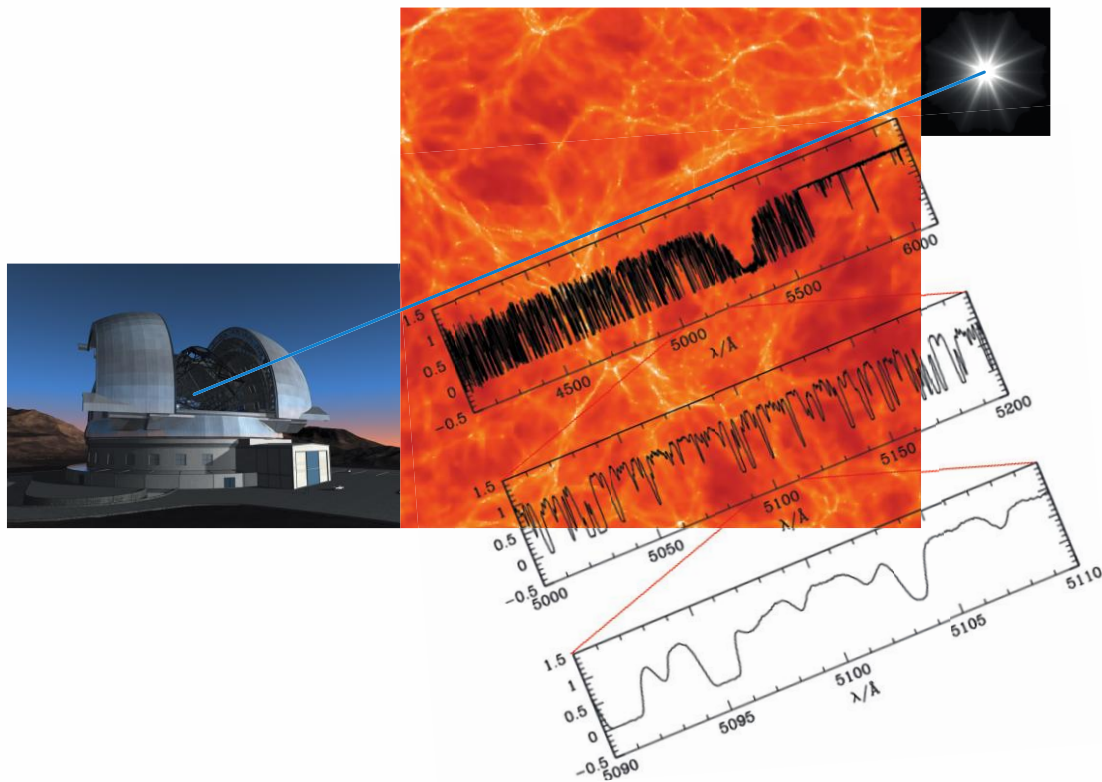

Figure 2.18. A distant quasar is used as a beacon in the Universe. Galaxies and intergalactic material that lie between the quasar and us will reveal themselves by the features seen in the quasar spectrum.

2.1.3.2 FUNDAMENTAL PHYSICS

What is the Universe made of? In the standard cosmological model, only 4% of the energy density of the Universe is composed of normal matter (gas and stars), while a further 23% is made up of some mysterious dark matter. For the remaining 73%, an even more enigmatic dark energy has been invoked. The E-ELT will explore the nature of this dark energy and our theory of gravity by probing two of its manifestations with unprecedented accuracy: the accelerated expansion of the Universe and the variability of fundamental physical constants.

2.1.3.2.1 How does the expansion of the Universe evolve?

The revolutionary observations made by Edwin Hubble in the late 1920s were the first direct evidence that the Universe was not static. The systematically increasing spectroscopic redshift observed in increasingly distant galaxies was a clear sign that the Universe expands. For a long time this expansion was believed to be slowing down due to the combined gravitational pull exerted by all of the matter in the Universe. However, at the end of the 1990s the measured dimming of Type Ia supernovae (used as standard candles) with increasing redshift revealed that this is not the case. Instead, there is now broad consensus that the expansion must have recently begun to accelerate! This result came as a surprise to most, but also as a big challenge. It has profoundly changed cosmology and implies a need for new physics. Indeed, the discovery of the accelerated expansion of the Universe has been awarded the 2011 Nobel Prize for physics.

2.1.3.2.2 Dark energy

Some form of dark energy, acting against gravity, is invoked by many cosmologists as an explanation for the accelerated expansion of the Universe. Ironically the simplest form of such a dark energy is the cosmological constant originally introduced by Einstein in order to explain a now discredited static Universe. With this addition, general relativity can explain this late acceleration very well. Alternatively, it has been proposed that general relativity should be replaced with a modified theory of gravity, which reproduces the new observational facts, but preserves the success of the original theory in explaining the formation of structures in the early Universe.

The most direct way of probing the nature of the acceleration in order to distinguish between these possibilities is to determine the expansion history of the Universe. Observables that depend on the expansion history include cosmic distances and the linear growth of density perturbations. Surveys of Type Ia supernovae, weak gravitational lensing and the signature that perturbations in the primordial baryon–photon fluid imprinted shortly after the Big Bang on today’s distribution of galaxies are considered to be good probes of the acceleration. However, extracting information about the expansion from these quantities relies on assumptions about the curvature of space, depends on the adopted cosmological model, and can only estimate the averaged expansion history over long periods of time.

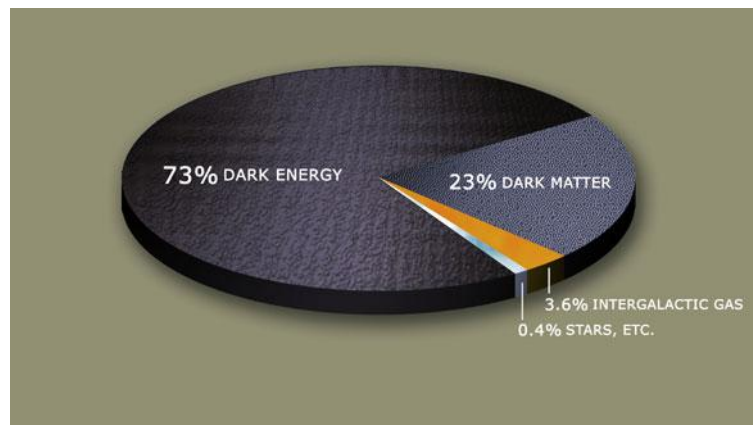

Figure 2.19. The mass–energy content of our Universe. The nature of both dark matter (23%) and dark energy (73%) remains an enigma.

2.1.3.2.3 A new approach — the redshift drift

A model-independent approach that measures the expansion rate directly was proposed as early as the 1960s, but limitations in technology did not allow astronomers to consider making such a measurement in practice. As the redshift of the spectra of distant objects is an indication of the expansion of the Universe, so is the change in this redshift with time a measure of the change of the rate of expansion. The estimated size of this redshift drift over a decade is only about 6 cm s^{-1} . This signal is about 10–20 times smaller than measurements made with today’s large telescopes. However, the huge light-collecting area of the E-ELT, coupled with new developments in quantum optics to record ultra-stable spectra, means that this amazing measurement now lies within reach: the E-ELT will be able to determine the accelerating expansion of the Universe directly, allowing us to quantify the nature of the dark energy responsible for the acceleration.

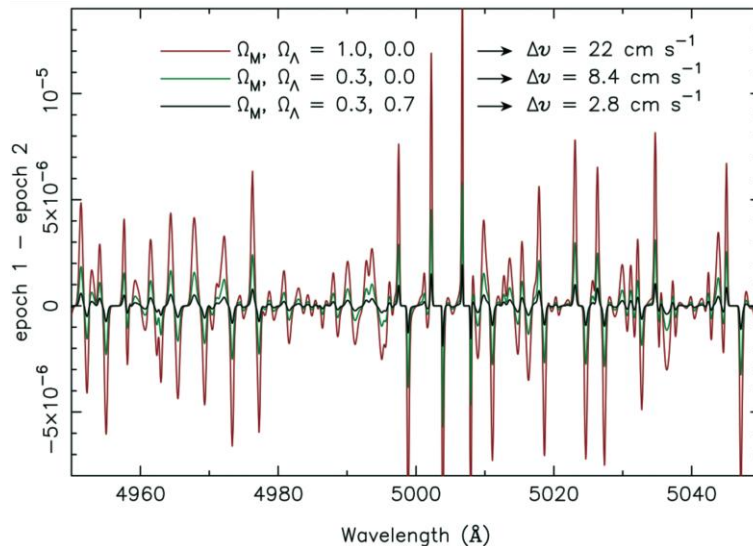

Figure 2.20. Simulation of the difference between two spectra of absorption systems at redshift 3, observed ten years apart. Depending on the cosmological parameters, Ω_M and Ω_Λ , the difference in velocity between the spectra varies by the tiny amounts of 2.8–22 cm s^{-1} . The E-ELT will be able to measure this redshift drift and so deduce the change of the expansion rate of the Universe.

2.1.3.2.4 Are the fundamental constants of physics really constant?

The values of fundamental constants in physics currently have no theoretical explanation: they just are what they are, and the only way we know their values is by measuring them in the laboratory. These fundamental quantities include the fine structure constant, α (characterising the strength of the electromagnetic interaction) and the strong interaction coupling constant, μ . The fine structure constant is central to our understanding of electromagnetism and is constructed from three other constants: the charge on the electron, e , Planck’s constant, h , and the speed of light, c . The strong interaction coupling constant, μ , is the ratio of the mass of the proton to the mass of the electron.

In the traditional understanding of physics, the laws of nature have always and everywhere been the same. This is an assumption that no experiment to date has been able to disprove, but ultra-precise measurements on the cosmological distances that the E-ELT will make possible may be able to challenge it. If this assumption does not hold, then the fundamental constants may vary with the epoch and location of the measurement. Such variations can have a profound impact on the physical properties of the Universe. An *a priori* upper limit is given by the fact that if the value of α were larger by just 4% in the early Universe, then the processes of nuclear fusion would be altered in such a way that the amount of carbon produced in the cores of stars would be drastically reduced, making carbon-based life impossible.

2.1.3.2.5 Strings, scalar fields, dark energy...

Theoretical models have been proposed where the variability of fundamental constants is due to a scalar field that is coupled to the electromagnetic field. We do not know whether such scalar fields exist, but they are predicted by a whole number of theories and the Large Hadron Collider (LHC) experiment at CERN could detect the first such scalar field very soon. String theory also suggests that fundamental constants may vary by a tiny amount, of the order of one part in 10 000 or 100 000. In this case, the variability is due to the changing size scale of hidden spacetime dimensions. Other proposed explanations for a possible variability of fundamental constants are related to the contribution of dark energy to the energy density of the Universe.

Astronomical observations probe much longer timescales and are therefore much more sensitive than laboratory experiments to possible variations in the fundamental constants. By exploring the spectra of distant quasars, the variability can be probed over a large fraction of the history of the Universe. A team led by Australian researchers has applied the “many-multiplets” method to the problem. This method measures the relative shifts between iron and magnesium absorption lines (among others), leading to claims of a detected variation in the value of α . The team measured a very small relative variation of

$\Delta\alpha/\alpha \sim -6 \times 10^{-6}$. It has also been suggested that the strong interaction coupling constant varies. Studies of the vibrational and rotational states of the hydrogen molecule in damped Lyman- α systems have been claimed to vary at a level of $\Delta\mu/\mu \sim 2 \times 10^{-5}$. However all of these claims have been disputed.

The reason for not yet having reached a consensus is that the measurements involved are very challenging. Testing the variability of fundamental constants with quasar absorption line spectra is essentially a measurement of the relative wavelength shifts of pairs of absorption lines whose wavelengths have a different sensitivity to the fundamental constants. The strength of the constraint on the variability is therefore critically dependent on the accuracy of the wavelength calibration. The ultra-stable high-resolution spectrograph proposed for the E-ELT will essentially remove the systematic uncertainties due to the wavelength calibration which plague current measurements. It will improve the constraints on the stability of fundamental constants by two orders of magnitude. The E-ELT will thus confirm or disprove the current claims that fundamental constants vary and that we are living in a fine-tuned location of spacetime where the fundamental constants are conveniently suitable for life.

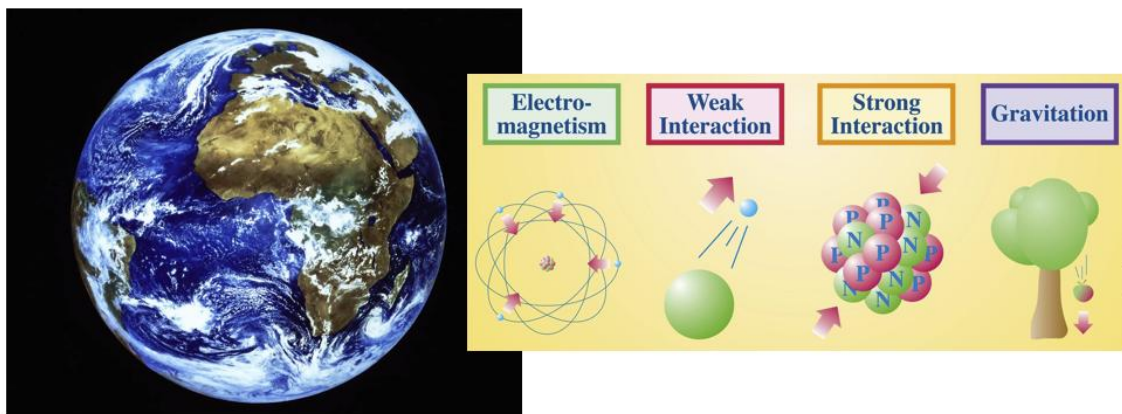

Figure 2.21. Are we living in a fine-tuned location of spacetime where the fundamental constants are conveniently suitable for life?

2.2 SYNERGIES

2.2.1 SYNERGIES WITH COMPLEMENTARY FACILITIES

When the E-ELT starts operations in about a decade from now, astronomy will be in a golden era. By that time, a rich heritage will have been gathered from today's working facilities. In addition, new and ambitious facilities complementing the E-ELT will be deployed on the same timescale.

By 2020, observations with current telescopes will have led to a significant accumulation of knowledge and inevitably stimulated many new questions. Discoveries with ground-based telescopes such as the VLT and its interferometer (VLTI), the GTC and other 8–10-metre-class telescopes will have prepared the scene for further fascinating discoveries with the E-ELT. For example, it is expected that in the field of exoplanets, many candidates for E-ELT follow-up will have been identified using highly specialised instruments such as HARPS, SPHERE and ESPRESSO. Also the first galaxies emerging from the Dark Ages will have been tentatively identified and will be awaiting the E-ELT for characterisation.

Synergy with the VLT and VLTI is expected to be particularly strong and efficient, as ESO already adapts its facilities for an optimal interplay between existing and future telescopes. Many VLT programmes, covering topics from protoplanetary discs to high-redshift star-forming galaxies anticipate the advent of the five-fold higher spatial resolution of the E-ELT. The VLTI starts working at similar spatial resolutions to the E-ELT, although only on the brightest targets. VLT and VLTI science will prepare for and smoothly dovetail with the discoveries expected with the E-ELT.

At the start of E-ELT operations, ALMA will have been exploring the cold Universe for a little less than a decade. A recent consultation of the ALMA and E-ELT communities (see the Workshops report below)

revealed a wealth of synergies between these facilities. The two key domains to profit from this synergy are the high-redshift Universe and star and planet formation. While ALMA will see the molecular gas in distant galaxies, the E-ELT will reveal the ionised gas — together ALMA and the E-ELT will revolutionise our understanding of galaxy formation. Similarly, the two facilities will probe different regions in nearby protoplanetary discs, ideally complementing each other in exploring the early phases of planetary systems. The E-ELT will also complement ALMA observations in many other research areas, e.g., by imaging jet collimation regions and the regions surrounding black holes.

An exciting scientific interplay can also be foreseen between the E-ELT and HST successor, the James Webb Space Telescope, the ambitious optical/infrared space observatory scheduled for launch in 2018. Indeed, just as the combination of 8–10-metre-class telescopes and the HST offered two decades of discoveries, the E-ELT and JWST complement each other perfectly (see the Workshop reports below). The 6.5-metre JWST, unhindered by the atmosphere, will be able to obtain deeper images, in particular in the infrared, while the 40-metre-class E-ELT will have almost seven times higher spatial resolution and will be able to collect fifty times more photons for high-resolution spectroscopy and studies of rapid time variability. In the study of the earliest galaxies for instance, comparison of mid-infrared data from the JWST and the near-infrared data from the E-ELT will be naturally complementary in furthering our understanding of the physical processes at work during the epoch of reionisation.

The next decade will further see the advent of many survey telescopes. ESO's 2.6-metre VST and the 4.1-metre VISTA will have been surveying the sky for a decade, supplemented by many similar facilities worldwide. These telescopes will be complemented by even more powerful survey facilities, such as the Pan-STARRS network and the 8-metre LSST, which will both ramp up over the next decade. While much exciting science will arise from these surveys directly, a wealth of understanding will flow from more detailed follow-up observations of targets identified by such projects. The E-ELT is being developed to optimally follow-up the survey discoveries. It will play a pivotal role in fully exploiting the surveys' scientific potential.

Existing or soon-to-be-launched space telescopes such as the HST, Spitzer, Chandra, XMM-Newton, the Wide-Field Infrared Survey Explorer (WISE), Herschel, Planck, CoRoT, Kepler and Gaia will have been working for a number of years as the E-ELT starts operations. These missions will have produced a major legacy for the E-ELT to exploit. For example CoRoT and Kepler are revealing transiting exoplanets, which will be candidates for exoplanet atmosphere studies with the E-ELT. Gaia will have studied a billion stars in the Milky Way in detail, revealing rare jewels such as the first stars that can be followed up with nucleocosmochronometry with the E-ELT. Herschel, together with ALMA, will collect a sample of galaxies in the early Universe, awaiting the E-ELT to be resolved and analysed. Planck will observe the anisotropy of the cosmic microwave background over the entire sky with high sensitivity and angular resolution and will also create a catalogue of galaxy clusters through the Sunyaev–Zel'dovich effect that will need to be followed up with E-ELT optical/near-infrared imaging and spectroscopy. In a similar wavelength range as that to be covered by the E-ELT, WISE has surveyed the entire sky over the course of six months through images made in the 3–25 μm wavelength range.

The eROSITA instrument to be launched in 2013 will perform the first imaging all-sky survey in the medium X-ray energy range up to 10 keV with unprecedented spectral and angular resolution. This satellite is expected to operate for at least seven years and will provide the E-ELT with targets for the study of black holes and dark matter. The Fermi gamma-ray telescope, launched in June 2008 and with a lifetime of up to ten years, is mapping the high-energy Universe from pulsars to active galaxies and gamma-ray burst events.

In terms of planetary science the Stratospheric Observatory for Infrared Astronomy (SOFIA) will provide new targets from its research on composition of planetary atmospheres and surfaces; structure, evolution and composition of comets; and the physics and chemistry of the interstellar medium as well as stellar formation.

A number of facilities to be approved and commissioned during the construction time of the E-ELT could further contribute to amplify its scientific output. For instance, the Planetary Transits and Oscillations of Stars (PLATO) mission is an ESA-proposed space observatory, with an expected launch date around 2018 that would use a group of photometers to discover and characterise exoplanets of all sizes and

kinds around cool dwarf and sub-giant stars. In the same group of candidates, Euclid, a mission also planned for around 2018, aims to map the large-scale distribution of dark matter and to characterise the properties of dark energy.

The list goes on; it is only by using the amazing power of the E-ELT to understand the detailed physics of the objects discovered by these missions that the benefits from the huge investment in space technology will be fully realised.

Finally, plans for the Square Kilometre Array are advancing. Despite the very different wavelength regimes, the cosmology science drivers of the E-ELT and SKA are remarkably complementary. Survey observations with SKA are likely to follow up on the studies of the fundamental constants and dark energy made with the E-ELT. SKA will reveal a massive population of variable/transient radio sources to be targeted by the E-ELT. In many other fields SKA will probe the cold Universe, whereas the E-ELT can see the luminous one.

In summary, the E-ELT will be built on the most solid foundations: in the coming decade enormous progress is expected from the many ground-based and space observatories. While the E-ELT will have a sharper eye and higher sensitivity than all of them, it will profit from their capabilities to observe at other wavelengths or wider areas of the sky. The synergy between all these facilities will enable the most fascinating discoveries with the E-ELT.

2.2.2 THE E-ELT IN THE CONTEXT OF THE COMPETITION: GMT AND TMT

Two competing Extremely Large Telescope (ELT) projects, the Thirty Meter Telescope and the Giant Magellan Telescope, are currently planned in the United States in collaboration with several international partners. This section puts the E-ELT project briefly into that context.

The most important difference between the projects is their sizes, i.e., the diameters of their primary mirrors: the E-ELT has a diameter of 39 metres, the TMT a diameter of 30 metres and the GMT an equivalent diameter of ~ 24 metres. Accordingly, the E-ELT, with ~ 1000 m² photon-collecting area, will be over one and a half times as large as the TMT (~ 650 m²) and two and a half times as large as the GMT (~ 400 m²). Accordingly, the E-ELT's spatial resolution at the diffraction limit will be 30% better than that of the TMT, and nearly twice that of the GMT.

This difference would be equivalent to the difference between an 8-metre-class telescope and a 6- or a 5-metre-class telescope, respectively. In the E-ELT era, when adaptive optics will become routine, the difference in diameter will be even more decisive.

The GMT is a Gregorian telescope with a primary mirror composed of seven 8-metre diameter segments, seven adaptive secondary mirrors and a focal ratio at the instrument focus of $\sim f/8$ delivering a plate scale of ~ 1 mm arcsecond⁻¹ on the sky over a 20-arcminute field of view. Its key advantages are: the low number of reflections (two until focus), reducing the thermal background and making it an excellent telescope for mid-infrared observations; the wide field of view (four times larger in area than the E-ELT field of view, 16 times larger than the unvignetted E-ELT field of view), optimising it for multi-object, survey instruments; and last but not least, the instrument-friendly plate scale allowing for compact wide-field instruments, and detector pixels matching the seeing limit.

The TMT is a Ritchey-Chrétien telescope with a segmented primary mirror 30 metres in diameter, three reflections to the $\sim f/15$ Nasmyth focus where the plate scale over the 20-arcminute field of view corresponds to ~ 2 mm arcsecond⁻¹ on the sky. The TMT covers a large field of view similar to the GMT. It does not include adaptive optics in the telescope design, but foresees post-focal adaptive optics feeding several of the instruments. The large field of view could be exploited for multi-object, seeing-limited instruments, although the plate scale makes this challenging.

In comparison, the E-ELT with its 39-metre primary mirror and three-mirror anastigmat design including adaptive optics, delivers at the $\sim f/17$ Nasmyth focus, after five reflections, a 10-arcminute (5-arcminute unvignetted) field of view with a plate scale of ~ 3.2 mm arcsecond⁻¹ on the sky. As mentioned above, the E-ELT outperforms its competitors in collecting power and spatial resolution, yet it covers a smaller

field of view on the sky and is optimised for diffraction-limited (small field or single object) observations. It is not optimised for wide-field, seeing-limited observations.

The Design Reference Mission (DRM) and Design Reference Science Plan (DRSP) described below show that the E-ELT community has recognised the E-ELT's specific advantages. The vast majority of the proposed science cases exploit either the diffraction-limited spatial resolution (ten times better than the JWST), and/or the immense collecting power allowing for ultra-high spectral resolution spectroscopy of faint targets.

Two examples demonstrate strongly why the E-ELT followed this uncompromising route. In the case of exoplanets, the best contrast that a telescope up to 30 metres in diameter can achieve at a projected separation of 0.1 arcseconds is around $1:10^8$ – which restricts direct imaging, and thus the characterisation of exoplanets in habitable zones to planets as massive as Jupiter or potentially down to Neptune masses for the closest stars. In contrast, the E-ELT will reach an order of magnitude better contrast ($1:10^9$), accessing the realm of super-Earth exoplanets in the habitable zones (and even Earth-mass exoplanets for the closest stars) that we believe to be the best candidates to harbour life.

In the case of the direct measurement of the Universe's expansion history an increase of the diameter from ~ 30 metres to ~ 40 metres represents a significant improvement in sensitivity; sufficient to observe sources with about 2 cms^{-1} accuracy, needed on a large sample of faint quasars to perform the cosmic expansion experiment.

Thus, while the GMT and TMT will undoubtedly make great discoveries and produce breakthrough science, the E-ELT surpasses both in collecting area and spatial resolution. The E-ELT is the project that focuses most sharply on aspects in which the ELTs are strongest: very high spectral and very high spatial resolution.

2.3 DISCOVERY POTENTIAL

The previous sections presented the great scientific achievements to be anticipated with the E-ELT. These alone represent a giant leap in our understanding of the Universe and potentially the first step towards finding life beyond the Solar System. Yet, all previous telescopes have shown that, no matter how hard scientists have tried to predict the future, many of the greatest discoveries came as totally unexpected. Is this still possible in the case of the E-ELT?

The discovery potential of a telescope is, by definition, hard to quantify. However, the distinguished astronomer Martin Harwit pointed out in his landmark book, *Cosmic Discovery: The Search, Scope and Heritage of Astronomy* (1981) that one key indicator for discoveries is the opening of a new parameter space. The most likely new discoveries come by looking at regions within the vast parameter space, spanned by wavelength, spatial resolution, depth, time resolution, etc., where nobody has been able to look before.

The figures below illustrate nearly a century of discoveries in astronomy made by means of expanding the accessible parameter space. The E-ELT will work at wavelengths, in the units of these figures, of 10^{-3} to a few times 10^{-5} cm and will push the envelopes of these parameter spaces in these figures out by an order of magnitude. But the real strength of the E-ELT lies in the fact that it can do so simultaneously, in addition to providing an unprecedented depth. Indeed, in many cases, the parameter spaces below were opened by dedicated, specialised experiments, while the E-ELT will push back the envelope as a multi-purpose facility.

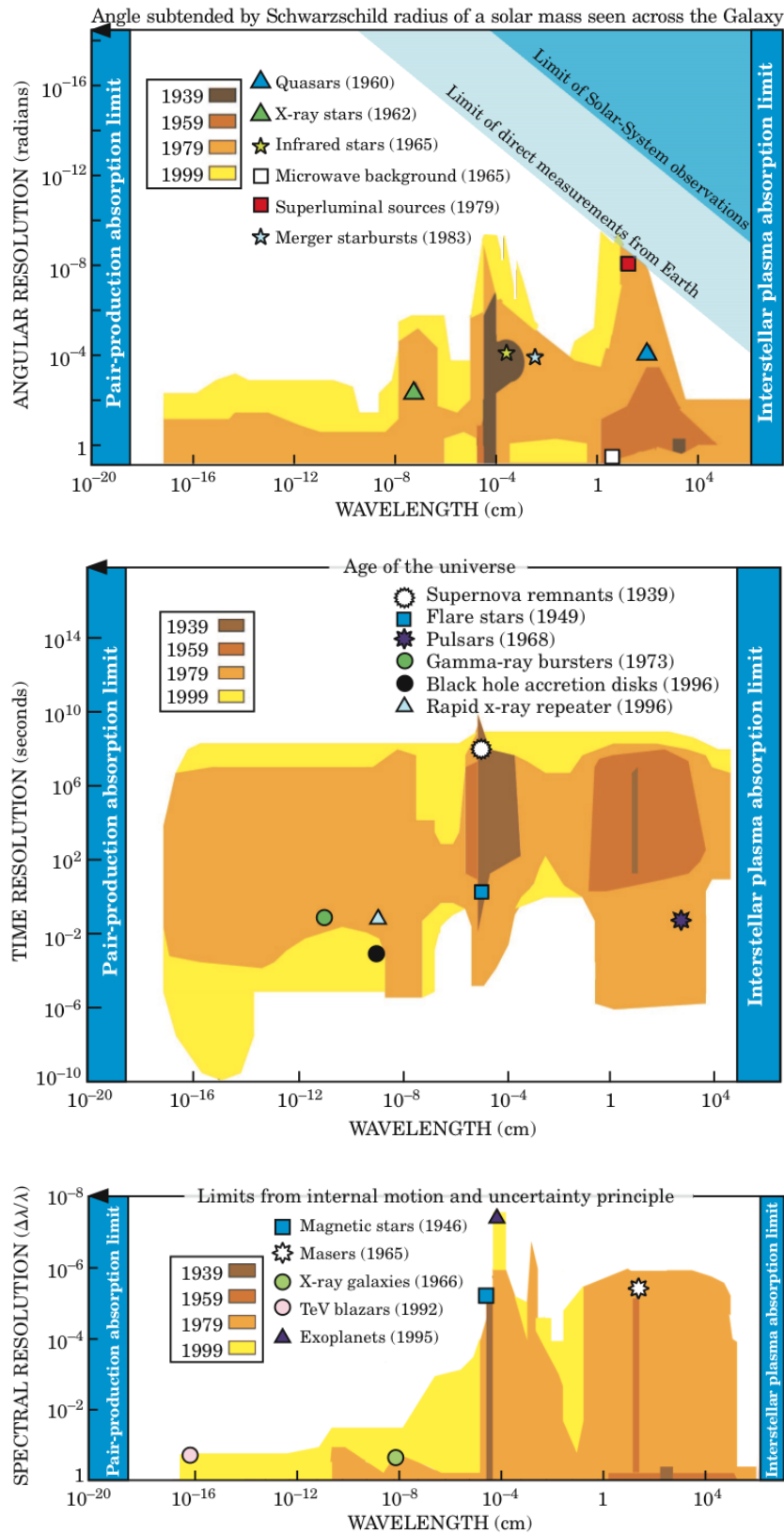

Figure 2.22. The figures illustrate the opening of the angular resolution, time resolution and spectral resolution as a function of wavelength during the course of the last century. The E-ELT (covering in wavelength from 10^{-3} to a few times 10^{-5} cm) will expand the parameter spaces simultaneously by nearly an order of magnitude. Taken from M. Harwit's article in *Physics Today* (November 2003) "The Growth of Astrophysical Understanding".

The E-ELT will open new parameter space simultaneously in at least three ways. First, the E-ELT will, thanks to its immense collecting power, increase the sensitivity of observations by up to two to three orders of magnitude (depending on the observing mode and wavelength range). This gain in sensitivity can be exploited in various ways. It can be used to image objects several magnitudes fainter than is possible today, and to reach depths competing with or exceeding the capability of JWST at shorter wavelengths, but surpassing it in spatial resolution by a factor of ten or more. The sensitivity can also be used to increase the spectral resolution on faint targets with current proposals for E-ELT instruments having spectral resolution of $\Delta\lambda/\lambda = 10^{-5}$, and instruments with $\Delta\lambda/\lambda = 10^{-6}$ being thought of for the future.

Furthermore, as already stressed above, the E-ELT will increase the spatial resolution by an order of magnitude, even improving on the image quality of future space telescopes. As a reference: JWST will have an image quality limited to about 60 milliarcseconds. The E-ELT, by contrast, will have a diffraction-limited resolution of 5 milliarcseconds at 1 μm wavelength (and even better at shorter wavelengths). Reasonably assuming that the second generation adaptive optics (e.g., upgrading the adaptive mirror in the telescope, or adding high-performance post-focal adaptive optics facilities) will enable diffraction-limited images at 500 nm wavelength, the spatial resolution of the E-ELT will shrink to 2.5 milliarcseconds — over a factor 20 better than JWST. An analogy can be drawn to the 1990s when the Hubble Space Telescope improved the spatial resolution over existing ground-based images by a factor of 10 to 20. However, the roles will be reversed this time: the improvement will come from the ground-based facility.

Finally, the E-ELT will open a new window on time resolution, ultimately enabling observations in the nanosecond regime. These leaps forward in what an optical–near-infrared telescope can do, coupled with advances such as unprecedented spectral resolution, new abilities to study polarised light, and new levels of contrast allowing us to see the very faint next to the very bright, demonstrate that we will open up an entire new range of possibilities.

As an anecdote: the VLT instrumentation plan put forward to the ESO STC in 1990 foresaw a speckle camera, at that time state of the art, to achieve high spatial resolution imaging. Adaptive optics was on the horizon, but not yet trusted as a technology. Could we have foreseen that ESO would deploy seven adaptive optics systems with the first generation of instruments? Or that an upgrade of the VLT to become an adaptive telescope would follow soon afterwards? Would people have dared to predict in 1990 that the VLT would image the first exoplanet?

It is in this great unknown that a large fraction of the ultimate excitement of the E-ELT lies.

2.4 COMMUNITY INPUT TO THE SCIENCE CASE

This section provides background information on the community input to the science case. First ideas were developed in the 1990s, and were taken forward through the next decade, on initiatives largely sponsored by the European Commission through Framework Programmes. The development of the science case was carried on by ESO in recent years, reaching out to the community through a number of large surveys and targeted workshops, and, last but not least, through the work of a very active E-ELT Science Working Group.

2.4.1 THE CONCEPTUAL PHASE

In Europe, the discussion of possible 25-metre-class ground-based facilities began in the early 1990s (see Ardeberg et al. [1993], Owner-Petersen et al. [1994] and references therein). The possibility of even larger telescopes, up to 100 metres in diameter, was soon explored (Gilmozzi et al., 1998). By the time of the first Bäckaskog workshop on ELTs in 1999, several concepts for ELT designs had emerged worldwide, and the range of revolutionary science that such telescopes might enable was beginning to be explored.

In 2000, under the Framework Programme 5, the EU-funded OPTICON programme (OPTical Infrared COordination Network for Astronomy, Principal Investigator (PI) Gerry Gilmore (see <http://www.astronopticon.org/fp5/>) initiated a work package for the development of the science case for an extremely large telescope. The goal was to bring together scientists studying the major European extremely large tele-

scope concepts at the time (namely Euro-50 and the OWL 100-metre concept) to produce a single science case. A scientist was hired to coordinate the activity, a list of interested contributors was set up and several workshops were organised, involving over 100 scientists from Europe and further afield. OPTICON continued to be funded under the Framework Programmes 6 and 7 (see <http://www.astro-opticon.org/fp6-index.html> and <http://www.astro-opticon.org/>) and continued to vigorously support developments on all fronts (telescope, adaptive optics, site, instrumentation, science) towards a European ELT.

The first phase of work culminated in the production of two documents in 2005. The first was a top-level brochure, aimed at non-specialists, summarising the science case for a 50–100-metre ELT. The brochure was printed and released in February 2005. This was followed shortly afterwards by the production of a full ELT science case document (about 150 pages). Three thousand copies were printed and three thousand CDs were produced. The document was released as hardcopy in July 2005 at the EU Astronomy press day in Dwingeloo, NL. (“The Science case for the European Extremely Large Telescope, The next step in Mankind’s quest for the Universe”, 2005, I. Hook, Ed.)



Figure 2.23. Executive Summary and Science Case for telescope of 50 metres to 100 metres, published in 2005 (available at <http://www-astro.physics.ox.ac.uk/%7Eimh/ELT>).

In December 2005, following a review of the OWL project, ESO formed five *ad hoc* working groups, involving participants from ESO and the community, to re-assess various aspects of ELT design and science. One of these, the Science Working Group, Chaired by M. Franx (Leiden, NL), was given the task of re-assessing the science case for an ELT in the range 30–60 metres in diameter. Between January and April 2006 the SWG met four times in person and held two teleconferences. Their report, released in April 2006, considered over 30 science cases ranging from studies of our own Solar System to the nature of the Universe itself, and picked out nine Prominent Cases which later formed the basis of the Design Reference Mission (Section 2.4.2.1). The April 2006 SWG report is available at http://www.eso.org/sci/facilities/eelt/science/doc/swg_report_06.pdf.

The work of the five working groups (on telescope, site, adaptive optics, instrumentation and science) was distilled by ESO into the new 40-metre-class European ELT concept, which was presented to the community at a workshop in Marseilles, France in November 2006. The meeting included one and a half days dedicated to science during which previous themes were developed and new ideas explored. The

science cases presented and discussed at this meeting, and the similar discussions at many previous and subsequent meetings, have shaped the science case.

The Science Working Group formally merged with the OPTICON ELT science activity in May 2006. The joint OPTICON-ESO ELT Science Working group (chaired jointly by M. Franx and I. Hook [Oxford, UK], and after April 2009 by I. Hook) has remained active throughout phase B.

Their activities as well as the membership can be found at <http://www.eso.org/sci/facilities/eelt/science/swg/members.htm>. The Science Working Group has followed the evolution of the project over the last few years and has continuously provided input to the project on all aspects: telescope, instruments, site and operations. It has been the main driver in synthesising all input into the science case presented in this document.

2.4.2 THE DETAILED DESIGN PHASE

During the detailed design phase, the Science Working Group, together with the project office, initiated two studies aimed at guiding the telescope design and the instrumentation roadmap. The first initiative, the Design Reference Mission, was aimed at exploring, through detailed simulations, the end-to-end requirements emerging from the key science cases for the E-ELT. The second initiative, the Design Reference Science Plan, called for a broad input from the scientific community in order to identify the full parameter range and the requirements needed to cover the entire science programme.

These initiatives were supported by two dedicated workshops at ESO in May 2008 and May 2009 (see <http://www.eso.org/sci/facilities/eelt/science/drm/workshop08/> and <http://www.eso.org/sci/facilities/eelt/science/drm/workshop09/>) and are described in more detail below.

Further input from the community came through the phase A and conceptual instrument studies carried out between 2007 and 2010, as well as through four workshops organised by the projects and partners aimed towards exploring dedicated interactions between the E-ELT and, respectively, ALMA, JWST, SKA, and survey capabilities.

2.4.2.1 THE DESIGN REFERENCE MISSION

The E-ELT Design Reference Mission encompassed a detailed, hands-on exploration of a selected sample of science cases through the analysis of simulated E-ELT data. The purpose of this exercise was (i) to provide a quantitative assessment of the extent to which the E-ELT will be capable of addressing key scientific questions, (ii) to assist the project in making critical trade-off decisions by quantifying their consequences in terms of scientific gains and losses, and (iii) to support the development of the E-ELT Science Case. The overarching aim of the DRM was to help ensure that the E-ELT will meet the scientific aspirations of its community.

The science cases studied by the DRM were selected by the E-ELT Science Working Group from their April 2006 report. In total, eight science cases, split into 14 subcases, were explored by the DRM, and these are listed in the table below. Although these cases were considered by the SWG to be amongst the highlights of the E-ELT science case, they were not intended to be an exhaustive list of the science that the E-ELT will do. They were rather chosen to encompass a wide range of different science topics and goals, and to exemplify cases that exploit and highlight the key capabilities of the telescope.

Planets & Stars	<p>S3: From giant to terrestrial exoplanets: detection, characterisation and evolution</p> <ul style="list-style-type: none"> • Direct imaging of terrestrial and giant exoplanets • Earth twins in the habitable zone of type-solar stars <p>S9: Circumstellar disks</p> <ul style="list-style-type: none"> • Imaging the planet-forming regions of circumstellar disks <p>S5: Young stellar clusters</p> <ul style="list-style-type: none"> • Characterising the lowest mass freely floating objects in star forming regions • The centres of massive dense young clusters: deep E-ELT infrared imaging and 3D spectroscopy • Giant planet-mass objects in the Large Magellanic Cloud
Stars & Galaxies	<p>G4: Imaging and spectroscopy of resolved stellar populations in galaxies</p> <ul style="list-style-type: none"> • The resolved stellar populations of elliptical galaxies • The chemo-dynamical structure of galaxies • First stars relics in the Milky Way and satellites <p>G9: Black holes/AGN</p> <ul style="list-style-type: none"> • A survey of black holes in different environments
Galaxies & Cosmology	<p>C10: The physics of high redshift galaxies</p> <ul style="list-style-type: none"> • The physics and mass assembly of galaxies out to $z \sim 6$ • High-resolution imaging of high redshift galaxies <p>C4: First light — the highest redshift galaxies</p> <p>C2: A dynamical measurement of the expansion history of the Universe</p>

Table 2.1. Design Reference Mission.

The DRM process began in 2007 with members of the Science Working Group and help from the community, drafting a DRM proposal for each of the DRM science cases. These proposals were written somewhat in the manner of a regular ESO observing proposal: they briefly summarised the science case and then described a more or less well-defined set of E-ELT observations designed to address the scientific question at hand.

The key task of the DRM was to answer, through extensive simulations for each science case, the following two questions.

1. What, precisely, can be achieved with the observations described in the proposal in a given amount of observing time, or, vice versa, how much observing time is needed to achieve a given set of science goals?
2. How do these results depend on the properties of the telescope, the instrument, the adaptive optics performance and/or the site? Which features of the E-ELT system are critical to the success of the proposal?

Followed by:

3. Identification of key requirements for each case and quantification of the scientific losses if the requirements cannot be met, thus helping the project to understand the scientific consequences of any trade-off decisions.

Although the DRM cases were partly selected for being challenging, even for the E-ELT, the DRM analysis has shown that the unique capabilities of the E-ELT have clearly inspired some ambitious thinking. Several of the DRM cases require hundreds and even thousands of hours of observing time. Neverthe-

less, the DRM simulations have confirmed the transformational character of several of these programmes: the E-ELT will undoubtedly revolutionise the field of exoplanet imaging; studies of resolved stellar populations of galaxies out to the Virgo cluster; the mass assembly of galaxies at redshifts of up to six; and provide the first ever dynamical measurement of the expansion of the Universe.

Several of the DRM cases were found (not unexpectedly) to be limited by the diameter of the E-ELT: exoplanet imaging and studies of resolved stellar populations in external galaxies are limited by the achievable resolution, while all of the high-resolution spectroscopy cases are limited by the telescope's photon-collecting power. These cases provide a strong motivation for a 40-metre-class telescope.

The DRM also identified the types and characteristics of instruments that are required in order to address the studied science cases. These requirements were cross-checked against the instrument specifications derived by the eight phase A instrument studies. The conclusion here was that the studied instrumentation suite was a good match to the requirements of the DRM science cases. The only exception is the capability of observing in the ultraviolet below 370 nm.

The full DRM report is publicly available through the project web pages (<http://www.eso.org/sci/facilities/eelt/science/>).

2.4.2.2 THE DESIGN REFERENCE SCIENCE PLAN

The E-ELT Design Reference Science Plan was designed and conducted to explore the full range of science cases for which the E-ELT will be used. It was meant to be a large collection of science cases provided directly by the future users of the E-ELT. Ultimately, it helped to define the boundaries of the parameter space over which the E-ELT will operate. It was used to guide the performance optimisation of the telescope, the prioritisation of the instruments, as well as to plan the science operation modes.

The DRSP was launched at JENAM 2008 in Vienna. In order to collect input efficiently from the community, the DRSP was set up as a web questionnaire, guiding the users through the submission of a dummy proposal for the E-ELT. The questionnaire prompted for the science case (title, abstract, category, ...), the identity of the authors (institute, stage of career, ...) before getting into details of the targets, spatial requirements, spectral requirements, type of instrumentation required, operations requirements, synergies, etc. The users were guided through the submission.

The questionnaire was available to the community from September 2008 until June 2009. During that period, 187 science cases were submitted by 151 principal investigators from 73 institutes across Europe. This well exceeded the goal to collect at least 100 cases. The entries have been collected into a large database and have been analysed statistically.

Proposals have been received from all ESO Member States. The UK, Germany and Spain feature prominently, followed by Italy and France. The number of ESO proposals was partly inflated by the E-ELT Science Office who additionally "submitted" all those DRM cases not already covered by the community. About two thirds of the PIs were faculty members, the other third being made up by post-doctoral researchers.

The proposals were classified into the four categories established for the ASTRONET roadmap (see www.astronet-eu.org). Three quarters of the proposals were shared between the categories "How do galaxies form and evolve?" and "What are the origin and evolution of stars and planetary systems?".

On the technical side, all instruments studied in phase A have been requested and almost all equally, with a slightly higher number of proposals for the only mid-infrared instrument, and a slightly lower one for the most specialised instrument: the planet finder. Only a very few proposals requested capabilities not included in the current studies, confirming that the suite of instruments presently foreseen (see below) covers the entire needs of the community.

The authors were also asked to indicate whether their proposal would work in synergy with another facility. More than a third of the proposals mentioned JWST, and about a quarter mentioned VLT/VLTI. The next most mentioned ones were ALMA and SKA.

Overall, the DRSP provided an extremely useful direct input from the community to the project. It has led to direct requirements on the operations scheme and strongly guided the Science Working Group in its recommendations.

The full DRSP report is publicly available through the project web pages (<http://www.eso.org/sci/facilities/eelt/science/>).

2.4.2.3 THE SCIENCE CASES FROM THE INSTRUMENT PHASE A STUDIES

Throughout the telescope phase B study, ESO launched eleven phase A / conceptual design phases for instruments and adaptive optics modules. The studies ran for 15 to 30 months starting in 2007 and explored a suite of instruments for the E-ELT. More than 200 astronomers and engineers in the ESO Member States and Chile contributed to the different studies. In particular, all studies formed strong science teams that built most compelling science cases to be addressed with the instruments. These science cases were very valuable additions to the DRM and DRSP efforts; they are described in Chapter 4 for each instrument.

The instrument characteristics and institutes forming the study consortia can be found in Chapter 4 or on the project web pages: <http://www.eso.org/sci/facilities/eelt/instrumentation/>.

In summary, the goals of the instrument studies were broad: to explore the scientific capabilities required to meet the E-ELT science goals, to examine the technical feasibility of the instrument, to understand the requirements placed on the telescope design and to develop a delivery plan.

The science cases developed by the instrument science teams largely surpassed in quality and detail the request of the project at this stage and added a large number of very high profile science goals to the E-ELT science case. They provided a solid basis for the instrument roadmap.

2.4.2.4 WORKSHOPS DURING THE DESIGN PHASE

Synergy Workshops:

Four workshops aimed at exploring the synergies between the E-ELT and other facilities were organised with the help of OPTICON between 2009 and 2011. This allowed the project to receive further input from the community on the already strongly perceived links between the E-ELT and other future large-scale facilities.

Title: ALMA and ELTs: A Deeper, Finer View of the Universe

Dates: 24–27 March 2009

Location: ESO Garching, Germany

Organiser: ESO

Participants: ~ 120

Website: <http://www.eso.org/sci/meetings/almaelt2009/>

Comments: The workshop explored the scientific synergies between ALMA and the planned ELTs. It was motivated by a growing interest in the ALMA and ELT communities to better understand the capabilities of these large facilities which are likely to dominate ground-based astronomy for the next two to three decades. One of the main goals of the workshop was to identify common science cases that drive both the ALMA and the ELT communities.

A summary was published in *The Messenger* (2009, Vol.136, 69) and all presentations are available on the conference web pages.

Title: JWST and ELTs: An Ideal Combination

Dates: 13–16 April 2010

Location: ESO Garching, Germany

Participants: ~ 110

Website: <http://www.eso.org/sci/meetings/jwstelt2010/>

Organisers: ESA/ESO

Comments: Similar to the above, the joint ESA/ESO workshop focused on the scientific synergies between JWST and the ELTs. The main goal of the workshop was to bring the JWST and ELTs (GMT, TMT, E-ELT) communities together, to identify the common science cases, and to outline instrumentation/upgrade priorities for the ELTs which would maximise the scientific return in key areas of scientific research requiring both facilities, namely the end of the Dark Ages — first light and reionisation; the assembly of galaxies; the birth of stars and protoplanetary systems; planetary systems and the origins of life. A lively meeting with intense discussion brought some interesting insight.

Title: Astronomy with Megastructures — Joint science with E-ELT and SKA

Dates: 10–14 May 2010

Location: Crete, Greece

Participants: ~ 100

Website: <http://www.physics.ox.ac.uk/users/Karastergiou/Greece2010/home.html>

Organisers: RadioNet and OPTICON

Comments: The third of the series of workshops exploring synergies was the workshop Astronomy with Megastructures — Joint science with E-ELT and SKA. As with the ALMA workshop described above, this meeting provided a valuable opportunity for the optical and radio communities to learn about the capabilities of SKA and the E-ELT, respectively. The workshop was mainly aimed at developing linked science cases for the E-ELT and SKA, although the roles of other future facilities, such as ALMA, JWST, LSST, GAIA, EUCLID and PLATO, were also discussed.

Title: Feeding the Giants: ELTs in the era of Surveys

Dates: 29 August — 2 September 2011

Location: Ischia, Italy

Participants: ~ 100

Website: <http://eso.org/sci/meetings/2011/feedgiant.html>

Organisers: OPTICON and ESO

Comments: This workshop aimed at exploring the synergies between the work of existing and forthcoming survey facilities and the Extremely Large Telescopes. It reviewed the projects in these two areas and addressed the developments that these will bring to a wide range of science areas, including exoplanets, star formation, stellar populations, galaxy formation/evolution and cosmology. It addressed two broad questions: a) Along with surveys conducted by current and forthcoming observatories, how will the upcoming dedicated survey facilities profit from follow-up by the ELTs? and b) To what extent do the ELTs require surveys to prepare scientific breakthroughs? The goal was to bring together the survey and ELT communities and to define first strategies to maximise the success of both paths.

3 TECHNICAL OVERVIEW

3.1 SITE AND INFRASTRUCTURE

The site characteristics are described here to show their influence on the design of the telescope. The design of the necessary infrastructure for the operation of the E-ELT within a single observatory takes into account the existing infrastructure at Paranal. Dedicated site monitoring is installed at Cerro Armazones.

3.1.1 CHARACTERISTICS OF THE SITE

Cerro Armazones, the selected peak for the E-ELT. It is 20 km from the existing VLT site at Cerro Paranal and the VISTA facility at the adjoining peak.



Figure 3.1. Cerro Armazones is 20 km as the condor flies from Paranal.

Armazones is well known to ESO as it was extensively tested as a potential site for the VLT. Moreover, it has undergone comprehensive testing by the TMT project which kindly made the data available to ESO. After the TMT testing was completed, ESO resumed its own testing at Armazones.

The altitude of 3064 metres above sea level does not pose logistical problems for operations and meets the science requirements for low precipitable water vapour and low operating temperatures.

The median seeing of the site (0.7 arcseconds) and coherence times (4.5 ms free atmosphere and 3.5 ms full column) are in agreement with the values used to dimension the quaternary unit actuator density and final fitting error.

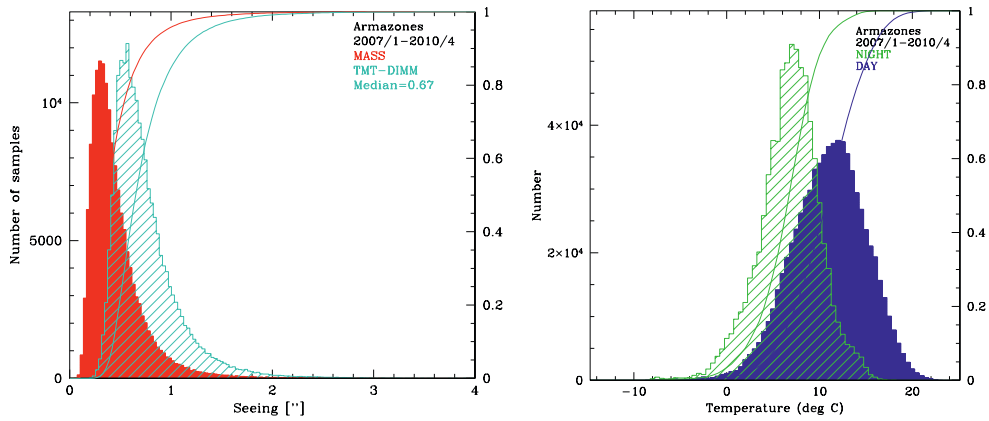

Figure 3.2. DIMM and MASS seeing and temperatures on Armazones.

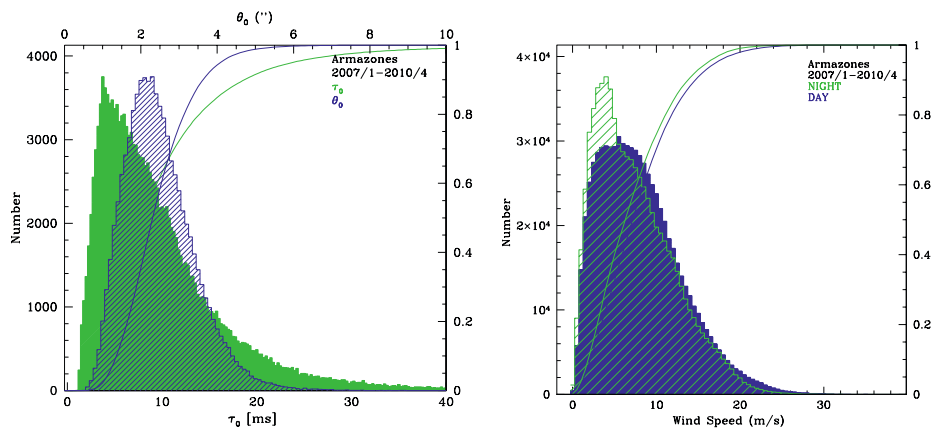

Figure 3.3. τ and θ_b and wind speed at Armazones.

The wind speed at the site is somewhat higher than at Paranal, but is compatible with the design characteristics of the E-ELT. The wind speed of 10 ms^{-1} used by the project to establish the diffraction-limited performance requirements is the 70th percentile of the site conditions and the 18 ms^{-1} telescope operational limit is within the 95th percentile.

The wind rose for Armazones is strongly focused to the north with almost no wind coming from the east. As with Paranal, this provides a natural location for the observatory heat dumps, which are unlikely to interfere with operations.

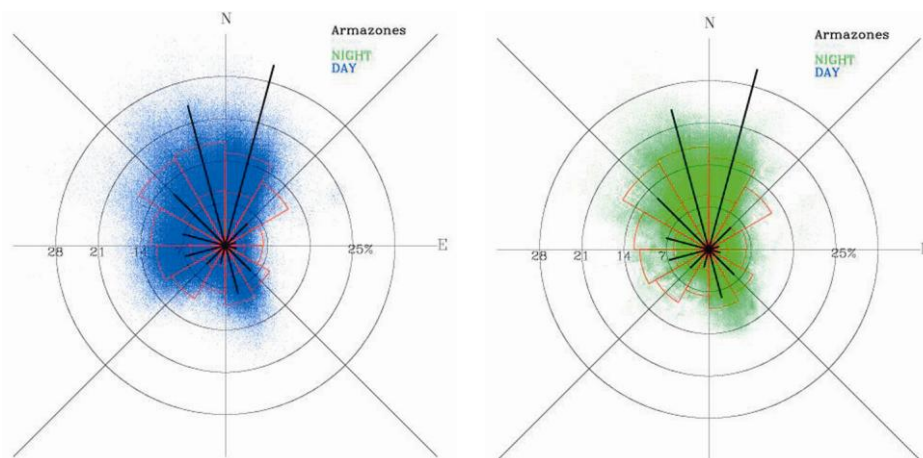

Figure 3.4. Day and night wind roses for Armazones.

Seismicity is an important parameter for any site and so the entire Paranal region has been evaluated for earthquakes. This work has been considered as an update of the work undertaken for Paranal. Such an update was considered worthwhile, both as an issue of due diligence and as a result of newer data becoming available in the intervening period of time. The project office commissioned two independent studies with expert firms in Europe to evaluate the newer data and provide the basic parameters for the surroundings of Paranal. The results of the studies were reviewed by expert firms in the Republic of Chile and by specialist consultants who were employed by ESO at the time of the VLT project.

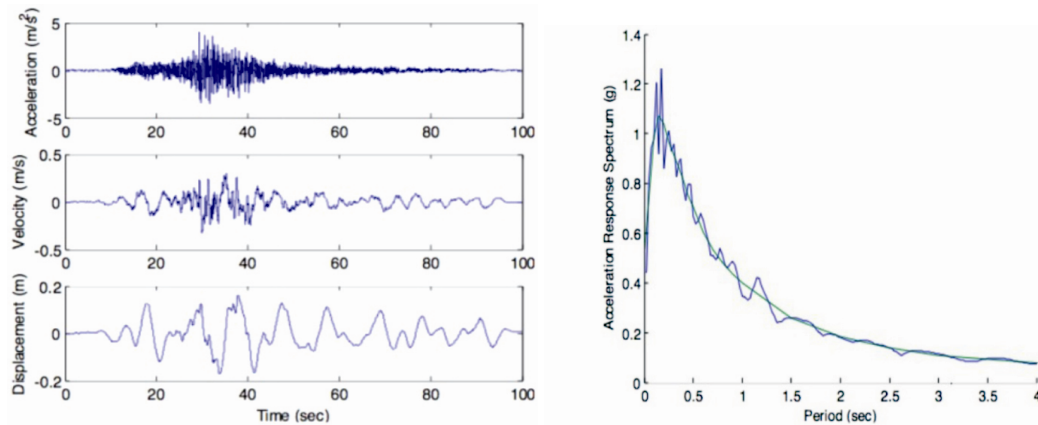

Figure 3.5. Typical earthquake time series. Peak Ground Acceleration (PGA) is the peak absolute value of the acceleration (left) and response spectrum from above time series. PGA is the 0 period value (right).

The output of all the work is a unique set of parameters for the site. The earthquake parameters adopted for phase B design are for a non-seismically isolated structure: an operations basis earthquake of 0.24g, a maximum likely earthquake of 0.34g and a collapse limit state of 0.6g. This would then correspond to the following limit states:

- Serviceability Limit state (SL): The structure is only slightly damaged. Structural elements have not reached significant yielding and have retained their strength and stiffness. Non-structural components such as partitions and infills may show some minor cracking that could, however, be economically repaired or even masked. No permanent drifts are present. This limit state is most influenced by the stiffness of the structural system.
- Damage Control limit state (DC): The structure is significantly damaged, but still retains considerable strength and stiffness. Vertical elements are capable of sustaining gravity loads, hence the structure is far from collapse. Non-structural components are damaged, although partitions and infills have not failed out of plane. Moderate and tolerable permanent drifts are present. The structure is repairable but at a non-trivial cost. This limit state is most influenced by the strength of the structural system.
- Collapse Prevention limit state (CP): The structure is heavily damaged, with very limited residual strength and stiffness. Although vertical elements are still capable of sustaining vertical loads, their resistance cannot be relied upon indefinitely. Most non-structural components have collapsed. Large permanent drifts are present. The structure is near collapse and would not survive another earthquake, even of moderate intensity. This limit state is most influenced by the ductility of the structural system.

The above three limit state formats yield four performance regions: from zero to SL is continued operation; from SL to DC is repairable damage; from DC to CP is irreparable damage; and above CP is collapse.

3.1.2 GEOGRAPHY AND LAYOUT

A suitable platform for the telescope can be generated on Armazones. The removal of approximately 300 000 cubic metres would result in approximately a 150 m × 150 m platform at the top of the moun-

tain. It is evident, and shown by the site testing and analysis of operational data from Paranal and other sites, that the minimal excavation and modification of the mountaintop are strongly recommended. Unsurprisingly, such a minimisation is considered advantageous from a construction cost point of view.

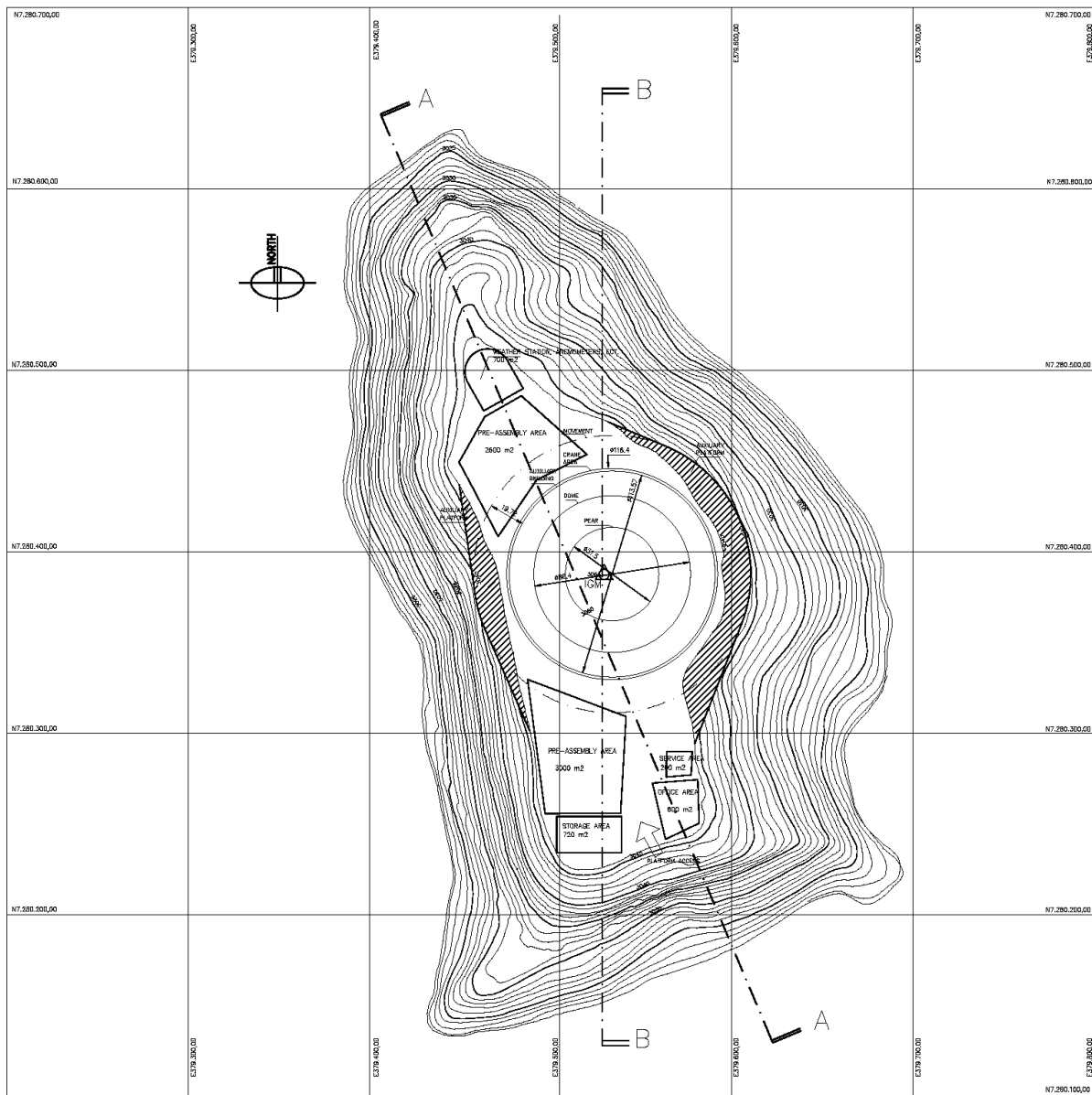

Figure 3.6. The platform.

The resulting site layout has the aforementioned platform (somewhat, but not significantly, bigger than the Paranal deck) at the top of Armazones. At the foot of the mountain, one kilometre from the deck, additional lay-down areas and temporary facilities necessary during construction will be provided.

3.1.3 LOGISTICAL ISSUES

During the construction phase, a temporary camp will be created at the foot of Armazones. The contractors and the ESO personnel overseeing the construction would use this camp.

A road will connect the Armazones site with the B710 road at almost the same location as the turn-off to Paranal. This will not disrupt the landing strip.

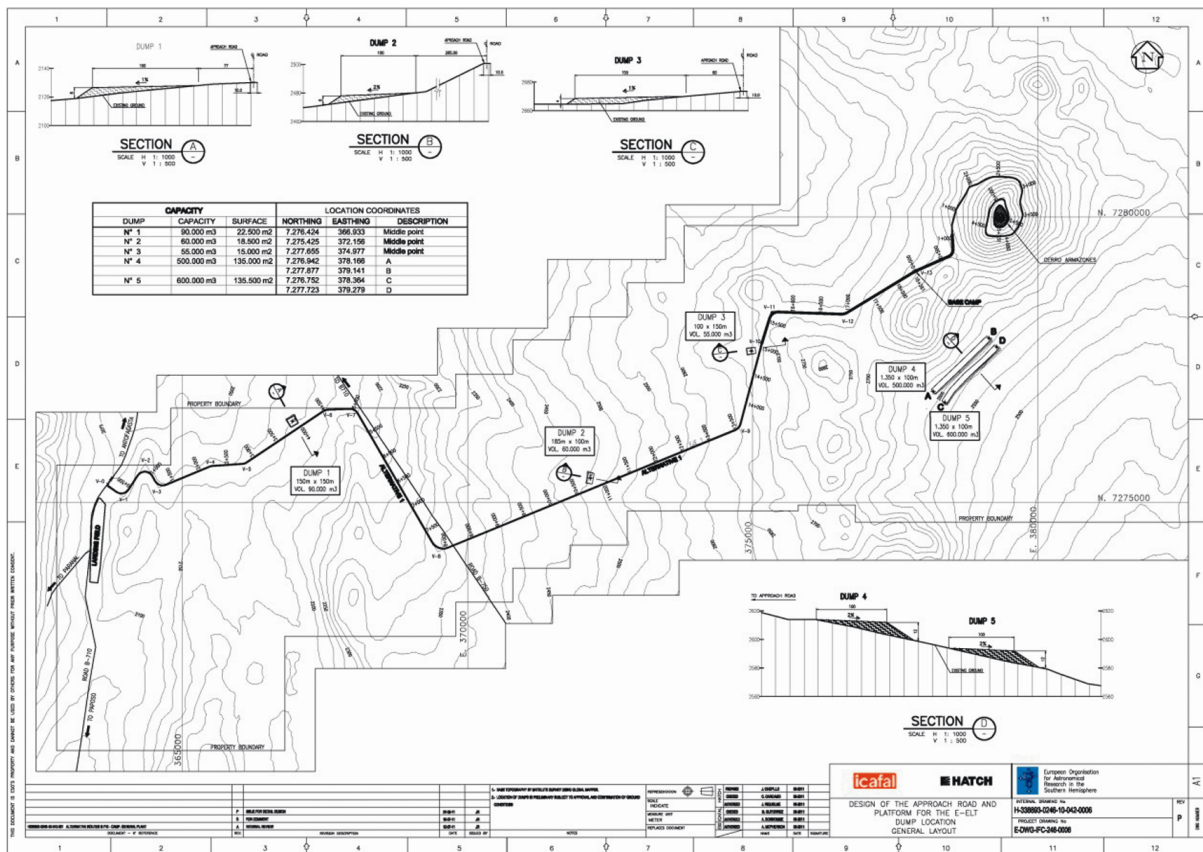

Figure 3.7. Road layout for the connection to Armazones.

During operations, the telescope will be a part of the Paranal facility with logistics management (catering, accommodation etc.), engineering resources and other facilities operated from there. Additional accommodation will be created on the Paranal site. The baseline solution would be to create a suitable accommodation facility, removed from the existing *residencia*, to provide night workers' accommodation for the entire facility, thereby freeing sufficient room at the existing *residencia* for day workers. No additional catering facilities are envisaged for Paranal.

The minimal operation on the Armazones element of the Paranal Observatory would have local facilities for storage and coating as well as firefighting and a small accommodation unit for reception and duty personnel. Integration facilities are to be shared with Paranal.

3.1.4 WASHING AND COATING FACILITIES

The baseline coating for the E-ELT mirrors is the protected silver used for VISTA. The Paranal Observatory already operates the 4.2-metre chamber using sputtering technology. The M1 coating facilities are located in the auxiliary buildings of the dome. This limits the handling operations to a minimum and reduces the risk to the optics. The observatory must handle two primary mirror segments per day and therefore it is assumed that at least two parallel lines of coating for segments will be needed to create a sufficient buffer for maintenance. The viability of the coating requirements of the E-ELT have been validated by limited studies undertaken by a number of firms under a price enquiry. Other mirrors will be coated at Paranal and suitable coating facilities will be made available.

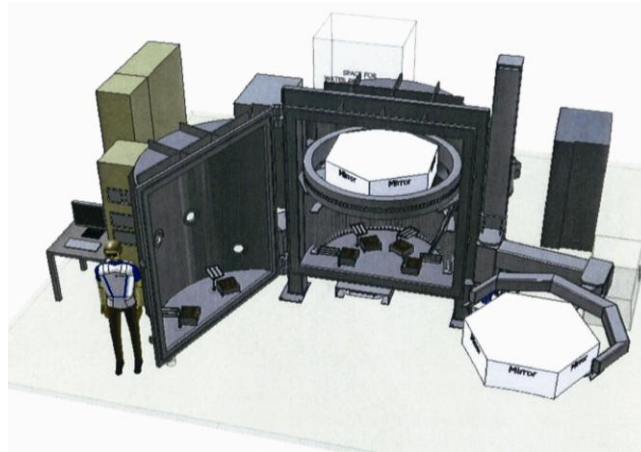

Figure 3.8. Segment coating unit.

The process for coating the thin shells for the quaternary is undergoing prototyping at Paranal in the context of the deformable secondary for the VLT. A high temperature process such as sputtering may be unsuitable as the stresses introduced in the glass by the glue attaching the magnets need to be established. Application of protected silver coatings using evaporation is also possible, and the individual segments of the thin shell are small enough that the chamber would be comparable in size to those for the primary mirror.

Storage space is foreseen inside the dome for the 133 segments in rotation.

3.1.5 POWER SUPPLY

The Armazones peak will be connected to one of the two Chilean grids as part of the agreement between ESO and the Chilean Government to host the E-ELT. The relevant power line will pass by Paranal, where a step-down substation will be erected to supply grid power to the VLT and to establish an electric power link between Paranal and Armazones. This substation does not form part of the E-ELT project. The Paranal power generating station will be expanded in its island-mode power capabilities by installing additional gas turbine generator sets equipped with the second, heat-recycling stage.

Figure 5.1: BFD of Case Study 0.BS

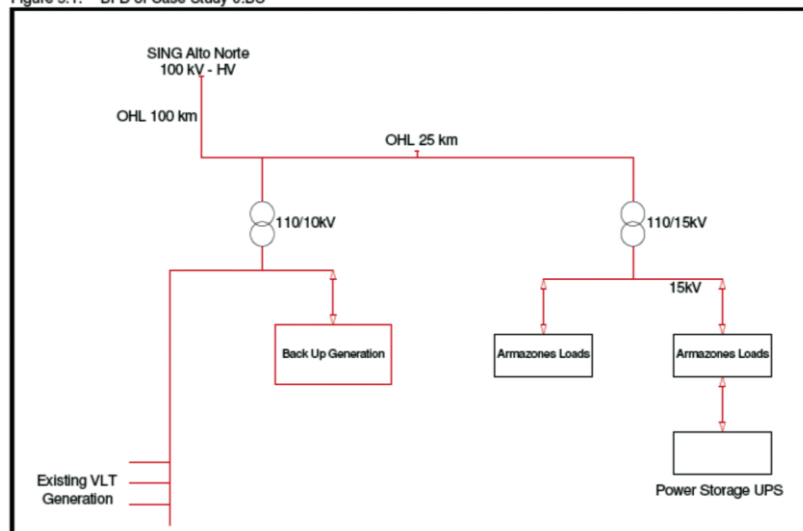

Figure 3.9. Power configuration layout for the E-ELT connection into the Paranal/Chilean grid.

The total generating capability of the Paranal power station would thus be increased to approximately 6 MW_e^\dagger , more than enough to place the domes and telescopes in a safe configuration and sufficient to operate the telescopes in a restricted power mode (slow slewing of the dome during the night and low air-conditioning demand during the day). Alternative energy supplies, either directly connected to the observatories or connected through the grid, are also being evaluated.

3.1.6 WATER SUPPLY

The Armazones peak, as is the case at Paranal, will be equipped with a 400 m^3 tank for firefighting. The increased presence of personnel at the integrated Paranal Observatory, and accommodated at the Paranal basecamp, can be handled within the existing water facilities although an increase in the water supply rate from Antofagasta will be required.

3.1.7 CHILLED MEDIUM PRODUCTION

The telescope subsystems receive a supply of chilled medium via a network of service connection points that are connected to the chilled medium supply via heat exchangers, thereby limiting the total length of piping. The chilled medium production has been analysed in detail in a design study contracted to IDOM. The maximum demand for cooling, 2.5 MW_{th} , comes during the day when the air conditioning of the dome is used to meet the extreme conditions of reducing the temperature by 5°C in 12 hours. The normal demand is forecast to be 900 kW_{th} for the dome during the day and 400 kW_{th} during the night (cooling the azimuth drives of the dome). The telescope cooling needs are estimated at 935 kW_{th} during observation, with 460 kW_{th} allocated to cooling the oil supply. The dimensioning case for the cooling is the maximum demand of 3.4 MW_{th} . Additionally, a heat loss of 50 kW_{th} and a pumping power of 100 kW_{th} are added into the total balance for the system.

Two options, propylene glycol and ethylene glycol, both in a 35% mixture with water, were considered with the latter being selected on cost grounds. The freezing point for the mixture is -17°C which is close to the survival limit for the Armazones site (-20°C). Given normal operating conditions, insulated pipes and operating pumps, it is considered extremely unlikely that freezing would occur.

The dome heat exchanger is dimensioned to transfer 2.5 MW_{th} of cooling while the telescope heat exchanger will operate at a peak of 750 kW_{th} . The load variations will be handled using variable flow rates. Commercially available electric compression chillers cooled by air with helical/screw compressors have been selected.

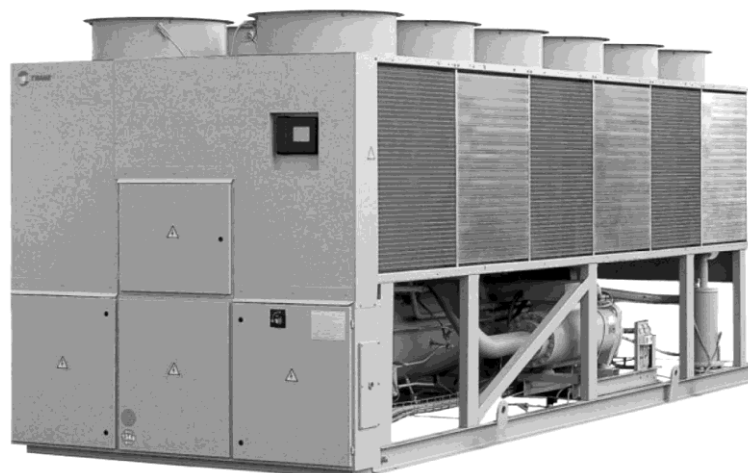

Figure 3.10. Chiller unit.

[†] To differentiate between electrical power demand and thermal power demand the unit symbol W_e and, respectively, W_{th} are used for the relevant unit, that is, the watt.

A study for the distribution of liquid nitrogen to the Nasmyth platforms has been undertaken and this is considered feasible. There is no provision for this at first light, but the ducting and allocation of space for such a facility is foreseen. The volume of liquid nitrogen required for the first years of operation does not justify the installation and maintenance of such a facility ahead of time.

3.1.8 NETWORK

The connectivity of the Armazones site with the Paranal backbone is already completed, within a project undertaken within the Framework 7 programme of the European Union (EVALSO), that in principle provides for fast access from Europe to the data generated at Paranal by the survey telescopes. This network foresaw the connection to Armazones and two pairs of fibres are already in place and commissioned for operation.

3.1.9 LOCAL FACILITIES

The operations plan requires that ten people can sleep on the Armazones peak. Rather than housing them in the dome, a small accommodation unit is to be constructed at the foot of the mountain. The house also acts as a guardhouse for the observatory — as the *porteria* at Pelicano does for La Silla.

3.1.10 AUXILIARY, COATING AND INSTRUMENT HANDLING FACILITIES

The dome foundations are ringed by an auxiliary structure that provides additional space that is planned to be used for distribution (power) transformers, equipment storage, coating facilities for smaller optics and a local control room for the commissioning period.

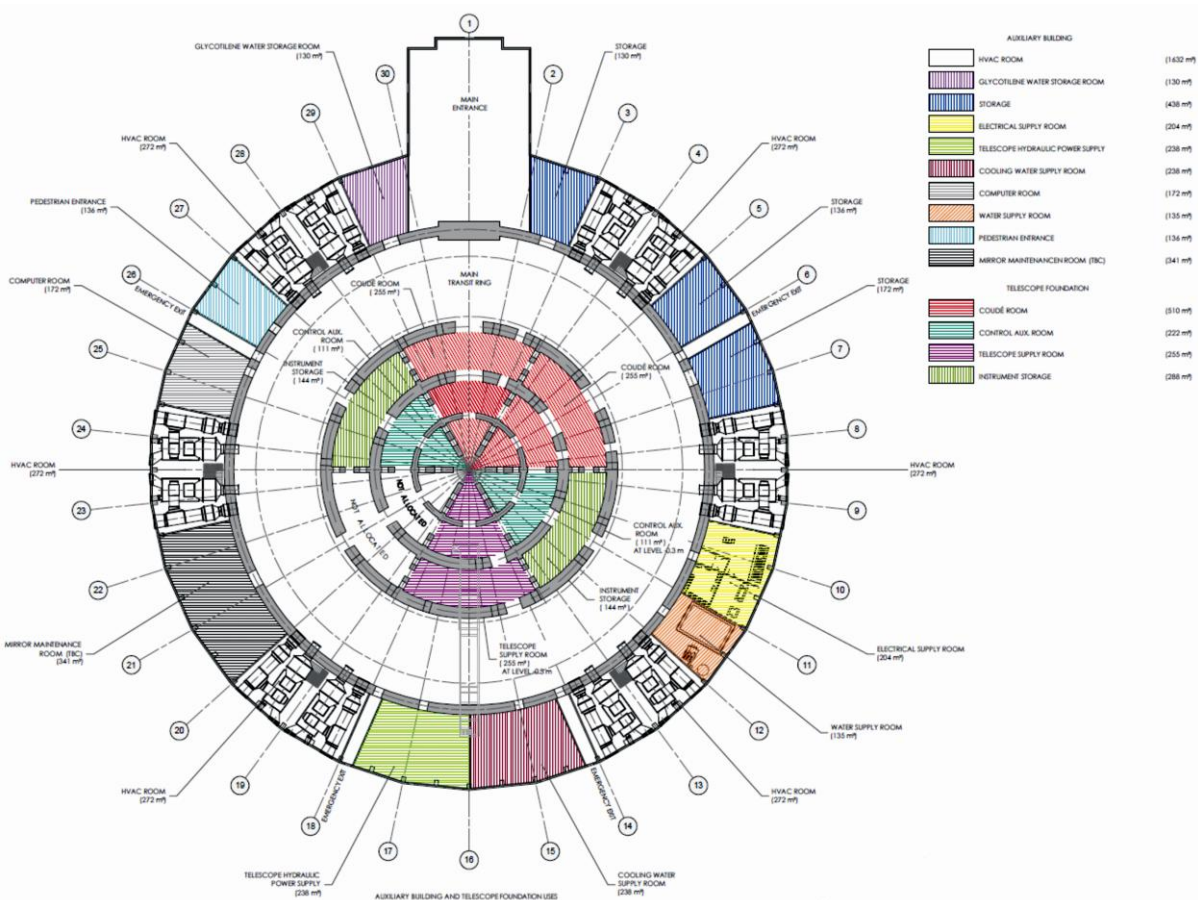

Figure 3.11. Minimalist site footprint including the coating chambers and instrument handling in the dome.

The baseline proposal is to operate the Armazones peak by accommodating staff at Paranal and leaving the Armazones peak with the minimal footprint. Operational scenarios are discussed elsewhere in the construction proposal. Here only the impact on the dome and other infrastructures is considered.

No handling equipment is expected to drive outside the dome volume and therefore airbag systems are foreseen as a baseline solution for the movements inside the telescope. Similar systems are used at Paranal for the movement of the primary mirror cell and coating carts.

3.1.11 CHALLENGES

3.1.11.1 CONSTRUCTION

The construction risk for the site is the possibility of a delay in obtaining access to the site for political or other reasons. Integration into the Paranal Observatory is considered to be a very strong mitigation strategy for this risk.

Geotechnical deviations from the established formations after excavation can result in an extended period to establish the platform. Assuming an early start to the excavations, the schedule has significant slack before the concrete foundations have to start. Geotechnical investigations are currently underway.

3.1.11.2 PERFORMANCE

The evolution of the site characteristics due to the cut of the summit to create the deck has been debated in the case of Paranal. It has been shown that the site evolution at Paranal has been due to shifts in the wind direction and not due to the cut of the summit. In any case, for cost reasons, the size of the platform is minimised.

3.2 DOME

A hemispherical dome with curved, laterally opening doors rotating atop a concrete pier is to house the telescope. The dome allows complete freedom for the telescope to position itself within the dome whether it be open or closed. The dome permits observations from zenith down to 20 degrees from the horizon. A deployable windscreen protects the telescope from high wind speeds, while many louvers increase the ventilation of the internal volume.

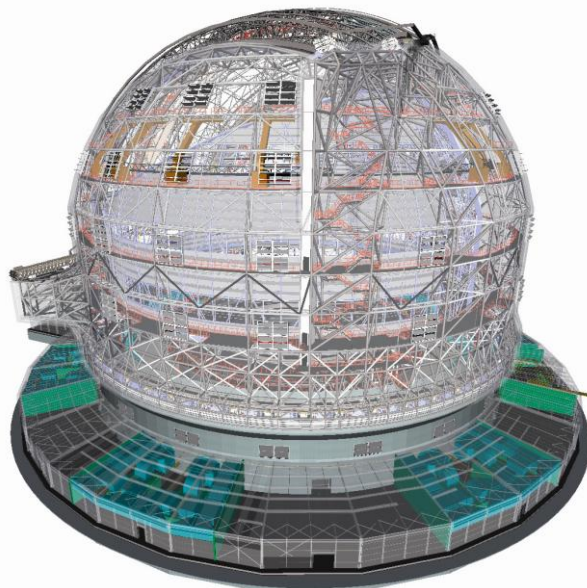

Figure 3.12. General view of the dome.

The dome is specified to be air- and watertight. Airtightness is critical to minimise the air-conditioning load and, while the need for watertightness is self-evident, it is perhaps the hardest to achieve. The current requirement placed upon the instruments being considered for the E-ELT is that they be able to generate their own calibrations without impacting the rest of the observatory operations. The absolute light-tightness of the dome is unlikely to be achieved but can be considered a byproduct of the airtightness.

3.2.1 FOUNDATIONS

The dome provides its own foundations as well as the concrete pier that lifts the telescope azimuth structure above the ground level, ensuring that the primary mirror remains more than 10 metres above the ground at all times.

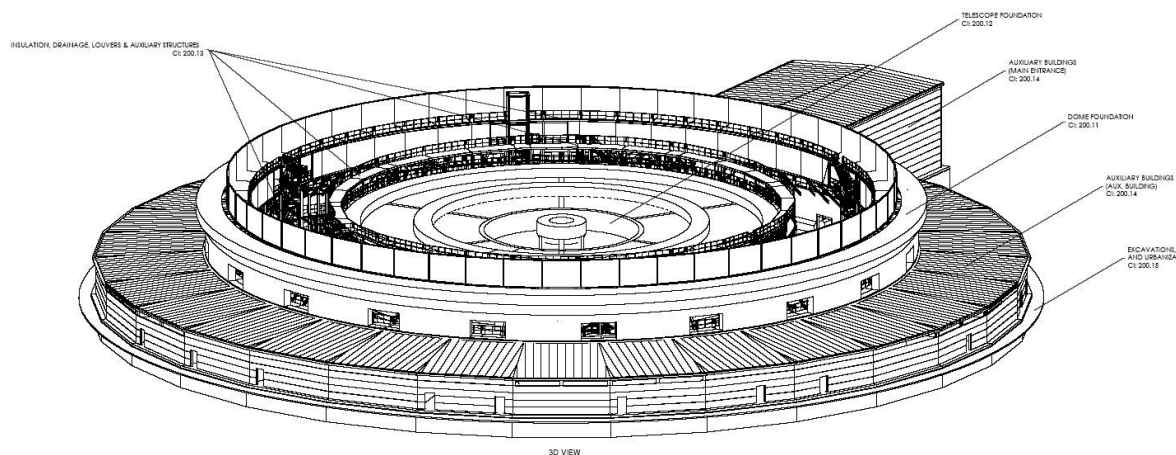

Figure 3.13. The components of the dome and telescope foundations.

The dome foundations consist of an 11.8-metre-high annulus of 1-metre-thick reinforced concrete. The diameter is 86.4 metres and the thickness of the pier is 1 metre. The foundation of the cylindrical wall is 3.64 metres wide and 1 metre deep. The top of the pier carries a 3.1-metre-wide and 2.8-metre-high crown structure upon which the upward facing bogies of the dome rotation are positioned. Excluding the ground slabs, the total concrete volume is 6290 m³ (15 725 tonnes).

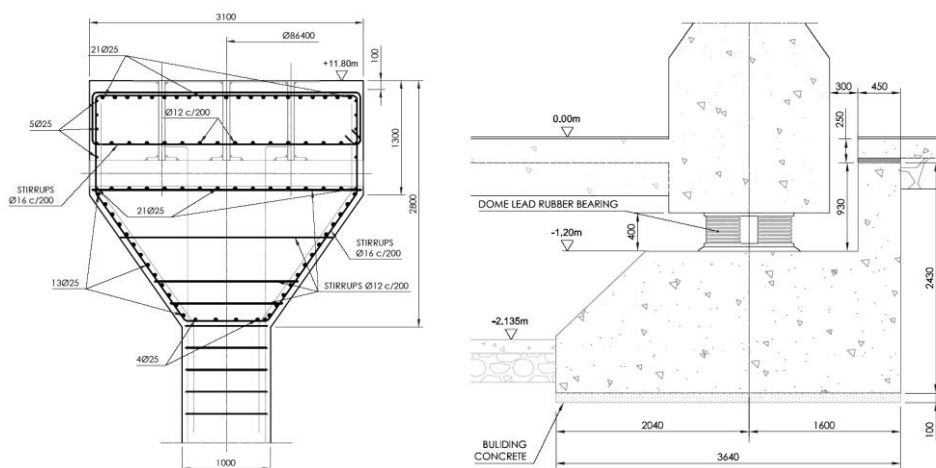

Figure 3.14. Dimensions for the crown and foot of the dome pier showing the seismic isolation.

The dome foundations are designed to take the maximum loads of the rotating part of the enclosure.

A large opening (8 metres wide and 7 metres high) in the dome foundations has been designed to allow large components to be brought in during construction and operation.

A concrete floor with significant load carrying capacity (20 kNm^{-2}) lies between the dome foundations and the telescope pier. Thermal joints separate each section of the floor to allow for horizontal displacement due to thermal effects and, additionally, to permit the motions allowed by the seismic isolation system.

The 9.3-metre-high telescope pier provides two load-carrying annular rings for the interface with the azimuth tracks of the telescope. The rings are 1 metre thick and have 2.2-metre-wide and 2.8-metre-deep crowns in which the azimuth tracks are installed. Additional stiffness is provided to the load-carrying beams by including radial walls every 15 degrees and 40 cm thick floor and 40 cm thick ceiling components that seal the foundations. The floor is located at the 8.125-metre level and extends outside the pier outer diameter to allow access to the lower part of the outer track for maintenance. The inner floor is similar to the dome floor with the same load-carrying capacity (20 kNm^{-2}).

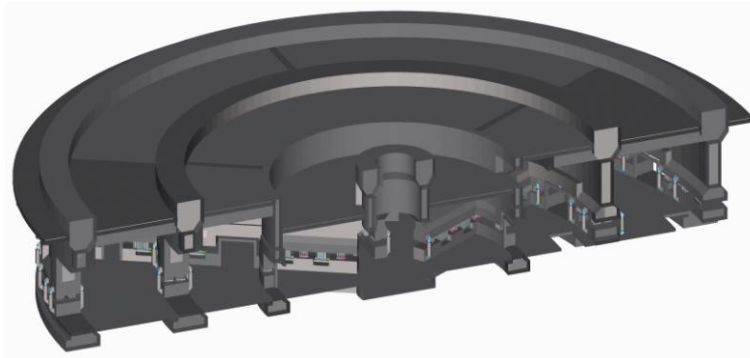

Figure 3.15. Telescope pier general view.

The performance of the telescope pier has been analysed using detailed finite element modelling to establish its impact on the eigenfrequencies of the telescope main structure and its ability to withstand the various load cases (e.g., earthquakes).

To determine the performance of the telescope pier an integrated finite element model of the telescope on the pier has been used.

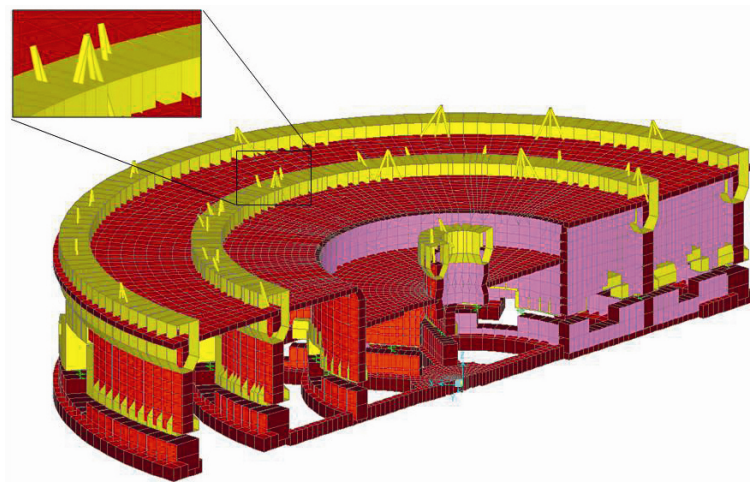

Figure 3.16. Finite element model of the telescope foundations and detail of the telescope foundations.

The foundations have been verified for stiffness. The global vertical stiffness is $44 \times 10^9 \text{ Nm}^{-1}$; the horizontal stiffness $20 \times 10^9 \text{ Nm}^{-1}$ and the stiffness in a tip-tilt mode is $2.8 \times 10^{13} \text{ Nm rad}^{-1}$; all meeting or exceeding the requirements imposed by the telescope performance. Similarly the deflections of the pier under the telescope loads are on average below the 0.225 mm requirement. Local deformations at the locations of the telescope hydrostatic bearing pads are below the 0.165 mm requirement. The eigenfrequencies of the telescope combined with the foundations are expected to drop by about 5%.

Whilst for the dome earthquake protection a conventional isolation system was chosen, for the main structure a more sophisticated system was selected, comprising springs, viscous dampers and pre-loaded units that provide adequate stiffness performance under operational conditions. The baseline isolation system (IDOM and Gerb) is located just above the bottom slab of the telescope foundation. In order to confirm proper functioning of the isolation concept and to determine various parameter assumptions, a scaled prototype of the isolated system will be tested on a shaking table. In addition, independent studies of seismic isolation systems for the telescope foundations have been carried out by specialist companies (SIRVE from Chile and ASDEA from Italy).

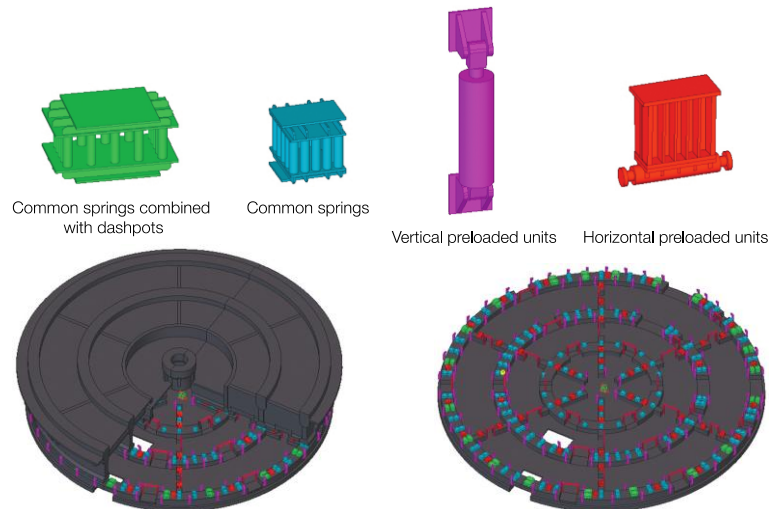

Figure 3.17. Seismic isolation proposal for the telescope foundations.

Transient earthquake simulations of the isolated configuration shows a significant reduction of telescope accelerations and base reaction forces. The seismic isolation system shows maximum deflections of 60 mm and 100 mm in the vertical and horizontal directions under the most demanding load combinations.

A gallery connects the equipment housed in the auxiliary buildings with the telescope pier.

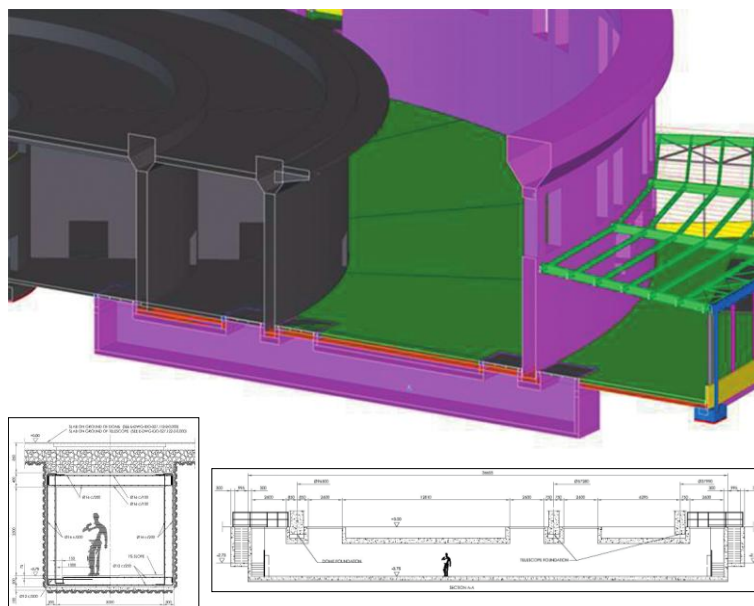

Figure 3.18. Gallery for telescope supplies.

Within the ribs there is ample room for coude instrumentation and other facilities such as the telescope cable wraps.

3.2.2 THE PRIMARY AND SECONDARY STRUCTURES

The size of the opening relative to the total dome size is very large. For reference, the ratio of dome to telescope size is however four times smaller for the E-ELT than for the 3.6-metre telescope on La Silla. A normal self-supporting space frame structure is not an optimum solution for this configuration of opening to diameter ratio.

The primary structure of the dome is formed from two slit arch girders, a nape/inner arch and a backbone arch, both resting on a base ring. The slit arches are located at the edge of the slit opening. The nape arch provides the stability at the rear of the dome while the backbone arch provides additional support for the door tracks.

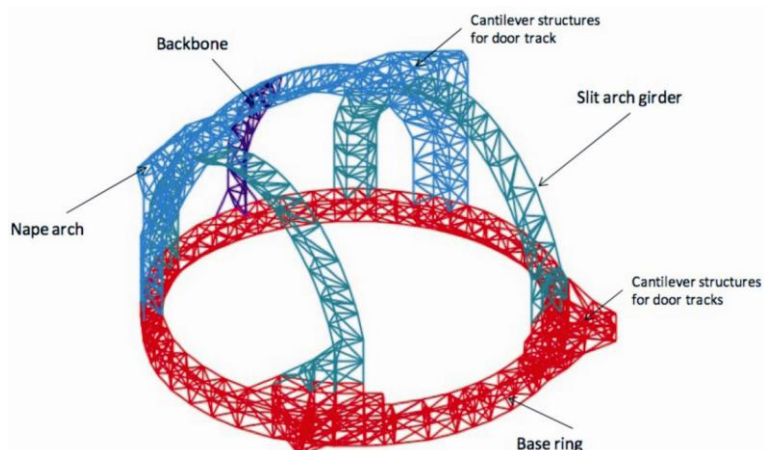

Figure 3.19. The dome primary structure.

Between the girders, a secondary structure is erected that carries the cladding of the dome. The secondary structure is based on vertical rib trusses and horizontal bracing. The cladding is mounted on trusses that are placed on this secondary structure. The horizontal bracing doubles up as walkways that permit access to all levels of the dome.

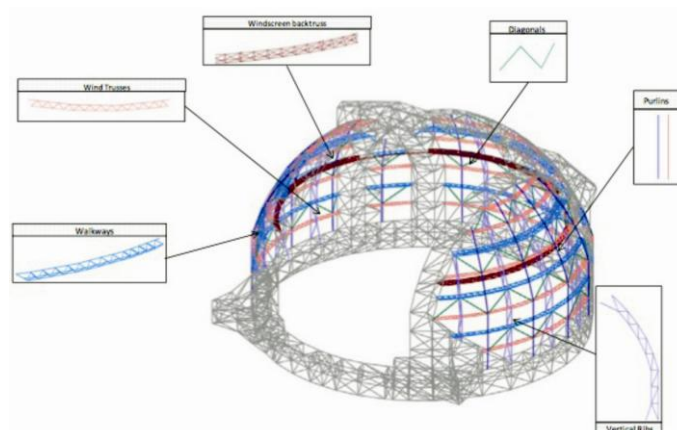

Figure 3.20. The dome secondary structure.

3.2.3 THE DOORS

The two slit girders and the nape girders carry the tracks upon which the doors travel. The door support is not isostatic as this would require larger overhangs and potentially very large deflections of the overhanging beams. A four-point support is ensured by the bogies that carry the doors. The relative flexibility of the enormous doors has been taken into account in the analysis and it is determined that the system is not over-constrained.

The door structure is based on two arch girders stretching from the top to the bottom tracks that are connected horizontally by a series of trusses. The dimensions of the doors create sufficient depth to house systems such as locking mechanisms and cranes.

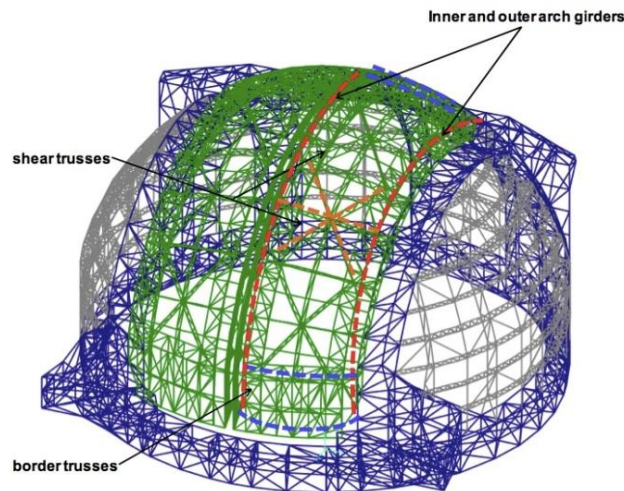

Figure 3.21. The structure of the doors.

The door bogies are oriented at 15 degrees to the vertical in the direction of the door loads. A chain drive system is foreseen to drive the bogies for the doors.

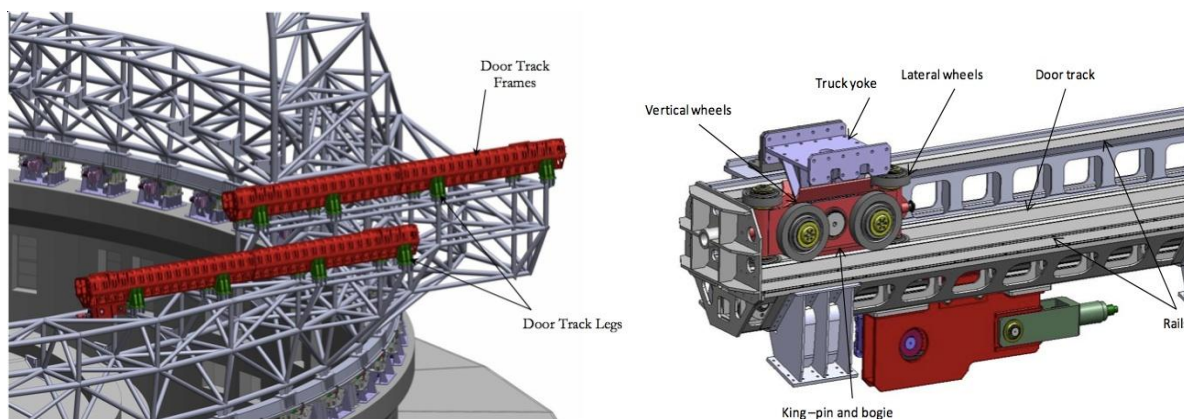

Figure 3.22. The door tracks and bogie.

The door bogie is composed of four main wheels (diameter 610 mm for the top bogies, diameter 740 mm for the bottom bogies) that are located with their axes normal to the predominant (operating) reaction load direction (about 15–20 degrees from the vertical plane) and four smaller restraining lateral wheels (diameter 465 mm for the top bogies, diameter 535 mm for the bottom bogies) in the perpendicular direction. The wheels roll on rails mounted within the track structure. The bogie is connected to the door using a yoke with a king pin and a spherical bushing, thereby allowing some load-sharing between the wheels.

The choice of a chain and sprocket system was preferred to a friction drive as it was considered more deterministic and the drive can be on the fixed part of the enclosure. The doors can close in three minutes with an average line speed of 0.15 ms^{-1} using 24 kW per motor.

The door control has been simulated and limits have been placed on the imperfections of the tracks. In addition, it has been determined that even with only one driving mechanism operational it is possible to

close the doors. The ability to close the doors under all operational conditions has been identified as a critical requirement by the project[‡].

The door locking mechanism is a latch-type system employing a single drive system that deploys a harpoon-like system into a latching mechanism. The same action engages and releases the clamp. A scaled prototype has been constructed to demonstrate the process. The mechanism permits the doors to be locked without a precise pre-alignment.

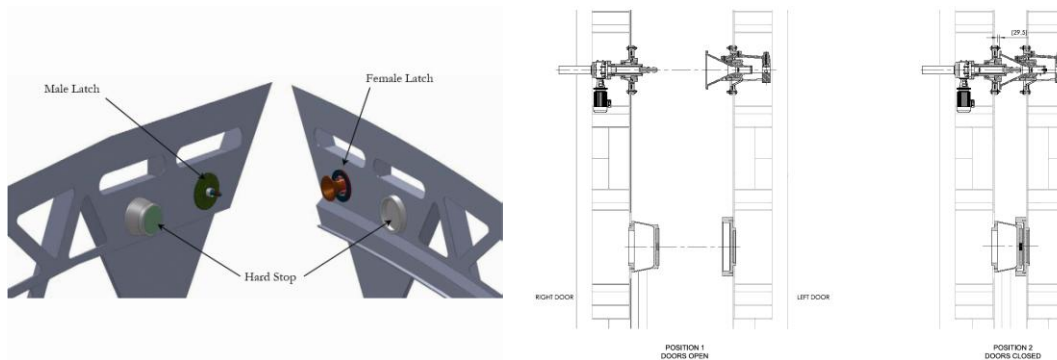

Figure 3.23. Door latching mechanism.

To seal the doors against water and to permit the dome to be pressurised for air conditioning and cleanliness, a combination of a water-capturing labyrinth and an inflatable seal is located in the doors.

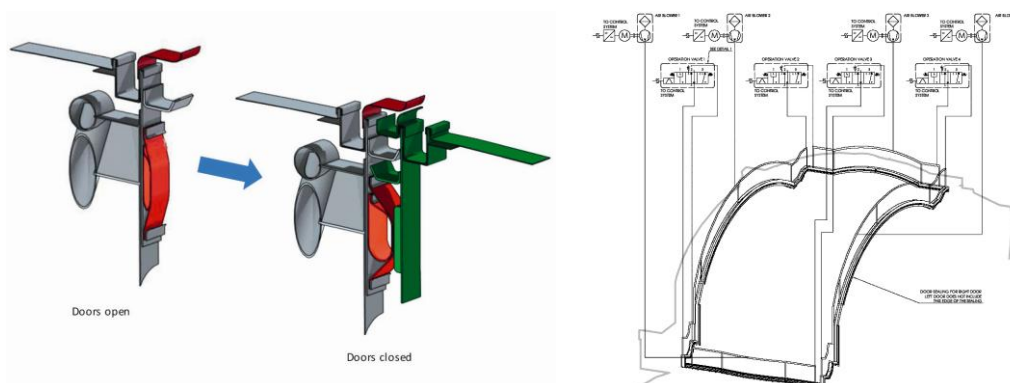

Figure 3.24. Door seals and water-labyrinth scheme.

The operating pressure of the GF+PTFE fabric seals is between 500 and 1000 Pa and, once inflated, they have an effective width of 250 mm. The total air volume in the seals is 39 m³ and the process of sealing the dome takes approximately ten minutes using four blowers. The compressed air system is located along the observing door edges to avoid complex connections.

3.2.3.1 ROTATING THE DOME

A large base ring on the rotating part of the dome provides the radial constraint for the two large arch girders that carry the doors and the cross-bracing arch nape girder in the back. This base ring also carries the rail upon which the dome turns.

The dome rotation is performed using 54 upward-facing bogies. The spacing of bogies is set at a 5/4 ratio with respect to the structure grid spacing, designed to avoid resonances during the travel.

[‡] In the words of the control team: “the observing slit doors are the most critical system in the whole telescope. If they don’t open we don’t do anything at all”.

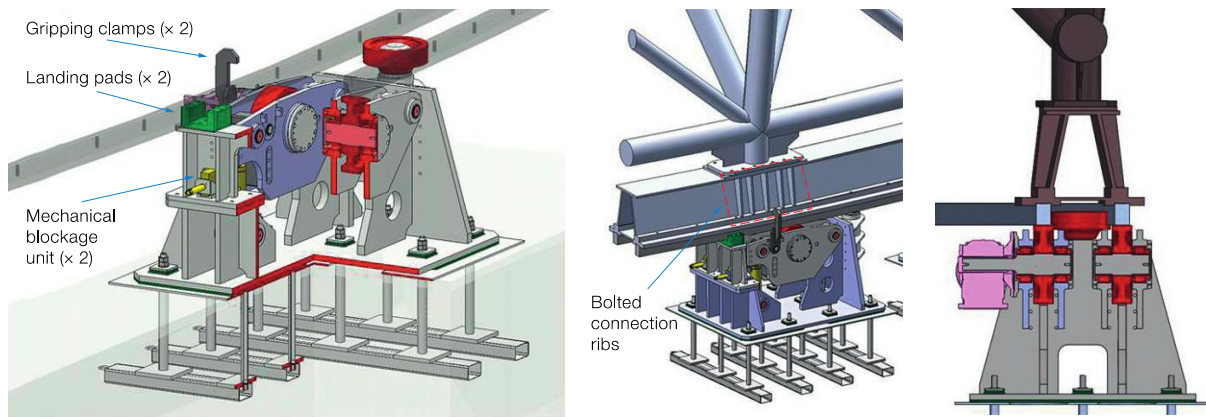

Figure 3.25. Left: Anchoring of the dome bogies into the crown. Right: Load transmission paths.

The choice between upward-facing bogies, resulting in variable loads on the bogies, and downward-facing, with constant, but in places, permanently higher, loads, was made by the suppliers. Each bogie has two sets of wheels mounted parallel to each other supporting the dome rotation on two tracks. The individual bogies have hydraulic actuators that permit them to be disconnected for maintenance, but also allow the distribution of the axial loads between different bogies.

In order to naturally follow the rotation of the dome, the vertical — conical in profile — wheels are inclined at 0.5 degrees with respect to the horizontal. This is achieved by vertically shifting the wheels with respect to the bogie structure. It is considered that this is an easier way of achieving the required precision. The spherical bearings used in the bogies are specified to work within this range without loss of performance. The bogies incorporate a provision for operating with blocks replacing the hydraulic cylinders in case of failure.

The 108 hydraulic actuators provide 770 kN lifting capacity and 515 kN pulling capacity, each for a total lifting capacity approximating 80 000 tonnes.

The power consumption of the dome rotation mechanisms is significant, peaking at approximately 2.5 MW_e.

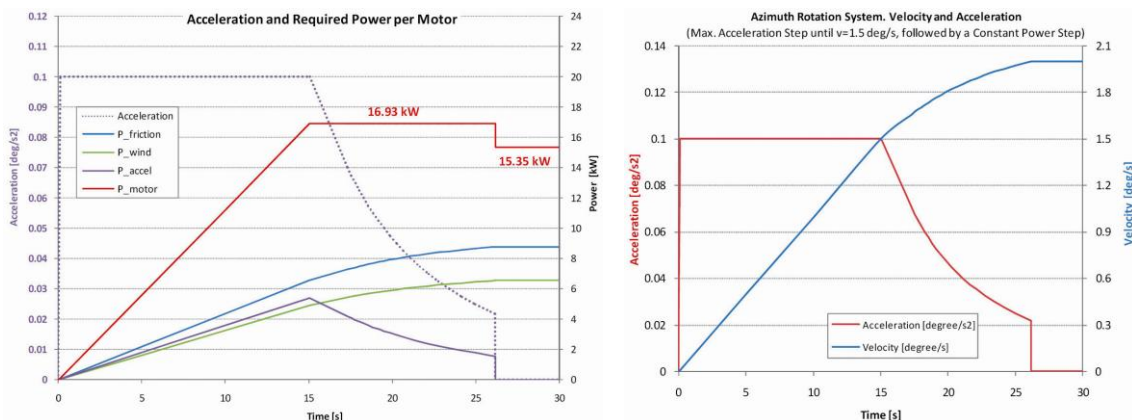

Figure 3.26. Dome rotation power demand per motor (left) and acceleration and velocity (right).

To avoid contamination of the dome volume by the heat dissipated by the drives embedded in the bogies, the entire azimuthal rotation mechanism is isolated and insulated from the telescope enclosure.

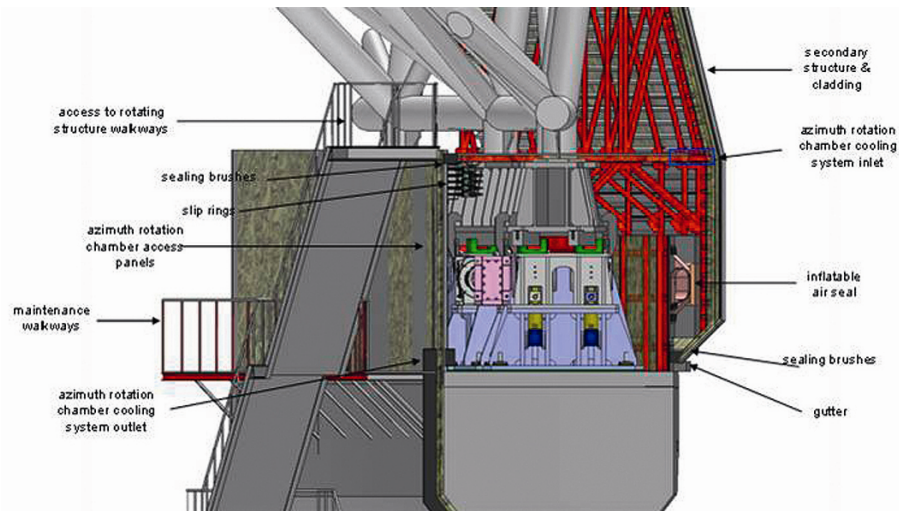

Figure 3.27. The azimuth rotation chamber.

This volume will be air conditioned whenever the drives are operational and the heat extracted to the normal Heating, Ventilation and Air Conditioning (HVAC) systems of the dome.

3.2.4 THE WINDSCREEN

With its large opening, the E-ELT dome requires the presence of a windscreen to protect the telescope primary and other mirrors, other than the secondary, from direct exposure to the wind.

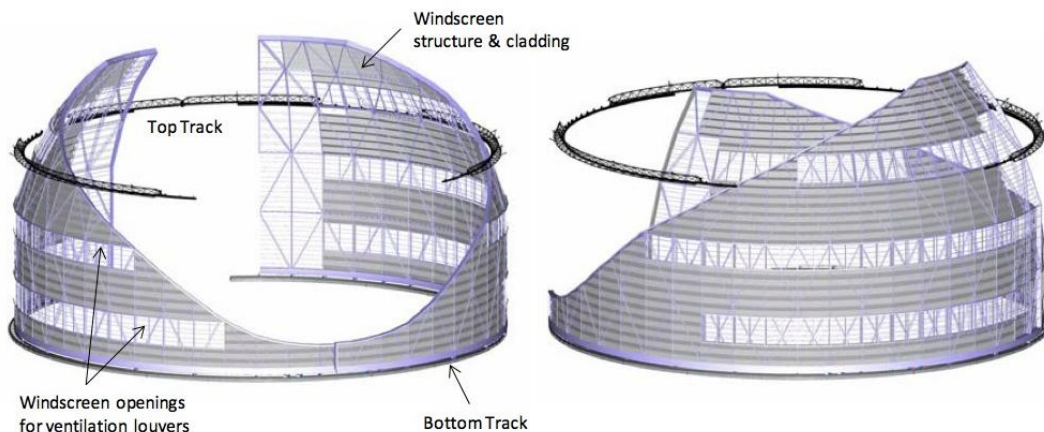

Figure 3.28. The windscreen solution.

The baseline design of the windscreen minimises the volume required to house it and limits the mechanisms operating in a variable gravity vector environment. Two spherical blades, either side of the observing slit doors, slide in front of the telescope aperture to restrict the wind. The blades are large but relatively lightweight. The horizontal rotation is performed using a rack and pinion motor driving the screen along two rails located at the bottom of the structure.

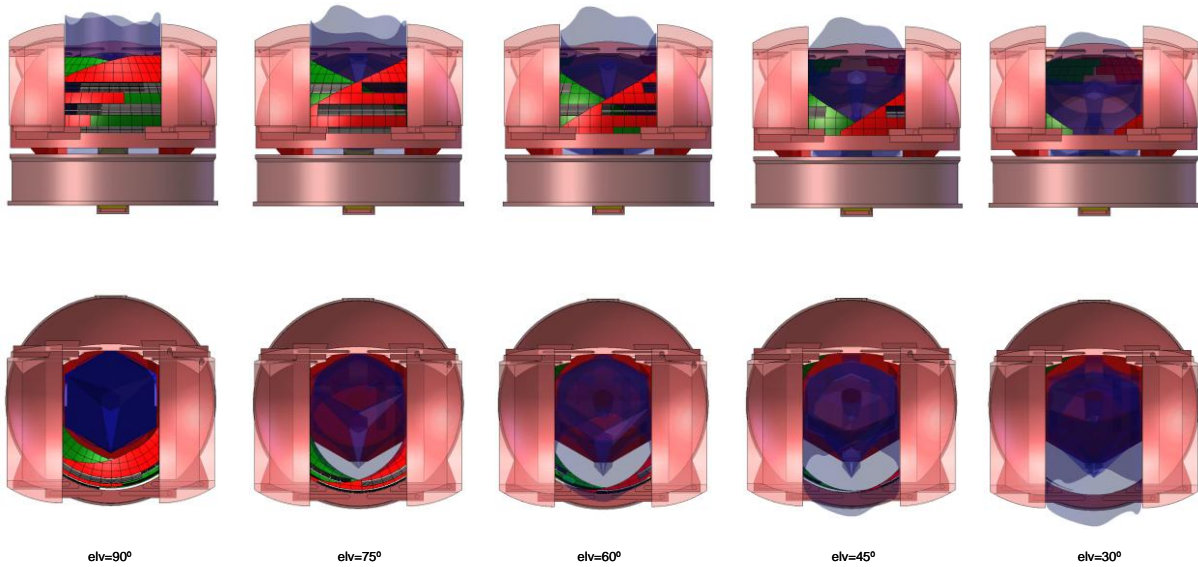

Figure 3.29. The windscreen deployed at different elevations.

Additional ventilation louvers are located on the windscreen in locations matching the louvers of the dome.

3.2.5 CLADDING

The dome cladding is designed to provide the maximum insulation during the day. Large ventilation louvers are located at regular intervals to allow the ventilation to be adjusted.

A single skin has been selected for the dome, based on a rain-screen panel system. An outer steel skin is formed by 1.5 mm sheets covered in Aluzinc effective coating. A naturally ventilated cavity of 100–150 mm is created to protect the inner layers from the effects of sun and rain or snow. Beneath the skin are a waterproofing membrane and the insulation layers, mounted on a structural panel that is then laid upon the dome.

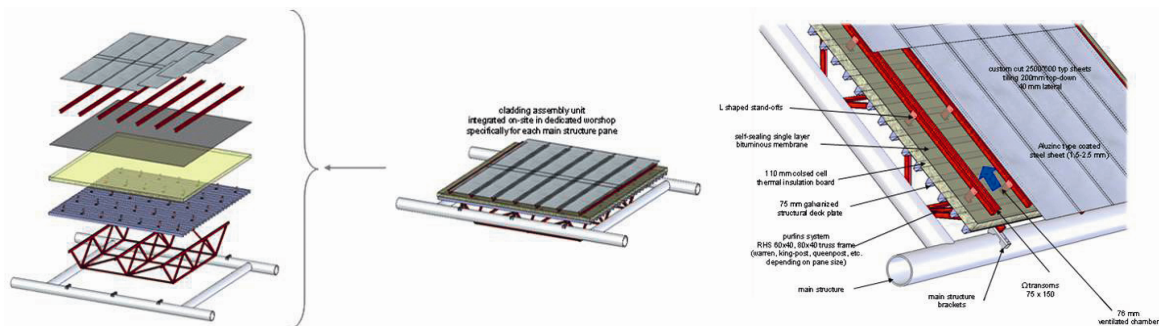

Figure 3.30. Details of the cladding structure.

Such systems are in common use in buildings with variable surfaces. A similar system is also deployed on the VLT domes. Three suppliers have been contacted with the baseline design and options are available for meeting the requirements of the E-ELT based on the specific manufacturing and construction technologies of these suppliers.

The dimensions of the panels have been determined using a 9 degrees radial and 6.66 degrees vertical grid. This results in all dome panels being approximately 5 metres long and where each panel in the same row is the same.

3.2.6 VENTILATION LOUVERS

Twenty ventilation louvers are located in the concrete pier just below the crown. A further 40 louvers are located in the dome-rotating structure in four levels. All louvers are 4 m × 4 m in size with four quadrants containing two slats each. A single motor using a chain moves all eight slats together. The slats are sandwiches with metal layers providing the internal and external skins and insulation filling the gap. The sealing is performed using rebates and soft seals at the edges.

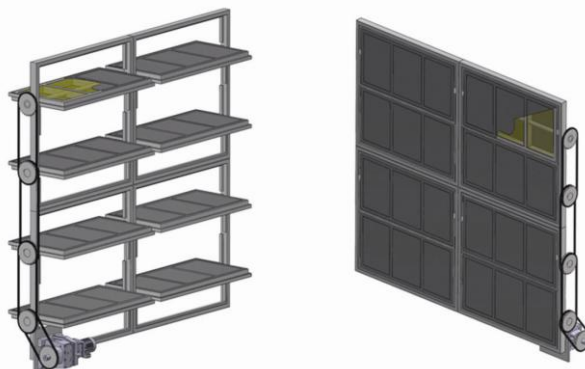

Figure 3.31. Louver design in open and closed configurations.

Two possible suppliers for the louver units have provided technical solutions for the louvers to the baseline design based on their own manufacturing and construction processes.

3.2.7 HEATING, VENTILATION AND AIR CONDITIONING

The air conditioning of the dome is necessary not only to thermally prepare the telescope for the forthcoming night, but also to keep the telescope optics clean.

For the purposes of airtightness, an ability to maintain a positive pressure of 50 Pa is specified. A conservative air leakage of $21 \text{ m}^3\text{s}^{-1}$ has been assumed across 8000 cm^2 of gap. This is considered achievable using seals on mechanisms (such as the inflatable seal described above) and double doors wherever possible. The Air Handling Units (AHUs) can provide up to $217 \text{ m}^3\text{s}^{-1}$.

The insulation built into the cladding has been estimated to cut down the thermal load on the dome due to solar radiation to $160 \text{ kW}_{\text{th}}$. The modelling of the telescope chamber assigns $1700 \text{ kW}_{\text{th}}$ of equivalent thermal inertia to the telescope system. This is the equivalent of cooling down the telescope by 5°C with respect to its starting configuration, a specification the air-conditioning system is required to achieve within 12 hours. Additional loads on the enclosure system are self-generating heat that has conservatively been taken to be $450 \text{ kW}_{\text{th}}$, i.e., in the condition of poor filtration in the air handling units ($270 \text{ kW}_{\text{th}}$ in case of clean filters), $70 \text{ kW}_{\text{th}}$ is lighting and handling equipment, 300 kW in the dome rotation system and $34 \text{ kW}_{\text{th}}$ in the windscreen drives. The telescope is assumed to be actively cooled and therefore that dissipation inside the dome volume is $100 \text{ kW}_{\text{th}}$, as well as a rather negligible 1 kW_{th} for human presence.

A detailed analysis of the performance of the air-conditioning system has been undertaken using the most extreme conditions found in the weather logs of the site. Four load cases were considered:

1. Combination of the highest logged difference between dawn and sunset with a peak solar radiation and peak internal loads;
2. The possibility of a rapid rise of the dew point and the need to avoid condensation inside the telescope;
3. The possibility of inverted demand (for heating rather than cooling);
4. The high-level requirement to be able to cool the telescope volume by 5°C in 12 hours.

Case 1, which can be considered the limit of a normal operational condition, is well within the power of the designed cooling system with a total peak demand of $1800 \text{ kW}_{\text{th}}$. In all cases, the HVAC system handles the loads required.

The total requirement is $2.5 \text{ MW}_{\text{th}}$ in a worst-case scenario. Critically however, for the power consumption at the observatory, the Armazones site does not experience wild variations in temperature. This is also important for the more inert components of the telescope, such as the mirrors, which are made of zero-expansion glass or glass ceramic that, by construction, does not react to temperature variations, but retains heat and, therefore, would otherwise be a source of thermal turbulence.

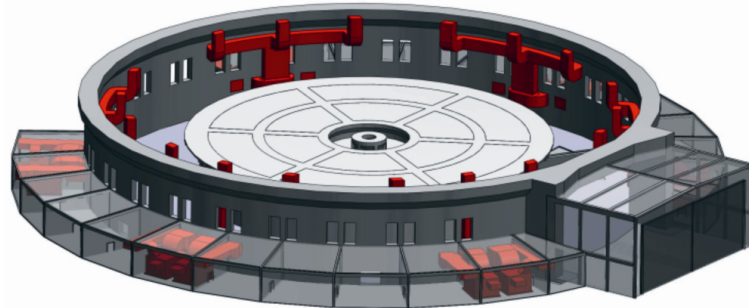

Figure 3.32. The distribution of the air handling units and ducting.

The design of the air-conditioning system avoids the interconnecting ducts employed between the rotating and fixed part at the VLT enclosures. Air handling units are placed at the base of the dome and high induction jet nozzles are located at the top of the concrete foundations. Twelve de-stratification fans are located at the +56 metre level of the dome with the nozzles at +65 metres. These 1.3 kW_e units move $13\,500 \text{ m}^3$ of air per hour and allow the recirculation of air to avoid trapping of warm air at the top of the dome.

3.2.8 VIBRATION CONTROL

The dome mechanisms and external perturbations are not permitted to transmit vibrations to the telescope main structure beyond the specified $0.5 \mu\text{g}/\sqrt{\text{Hz}}$. The value is selected to ensure that the dome contributions remain at the same level as the accelerations due to micro-seismicity. Until now, no specific vibration simulations have been carried out for the 39-metre baseline. Nevertheless, it can be assumed that the simulation results for the 42-metre remain valid to a large extent.

Dome mechanism induced vibrations have been considered to arise from the azimuth drives and from pumps or other equipment in the auxiliary buildings. A model of the dome structure and foundations as well as the soil propagation properties has been created and frequencies up to 100 Hz have been analysed. The soil has been assumed not to provide any damping while a conservative 1.5% damping has been assumed for the concrete.

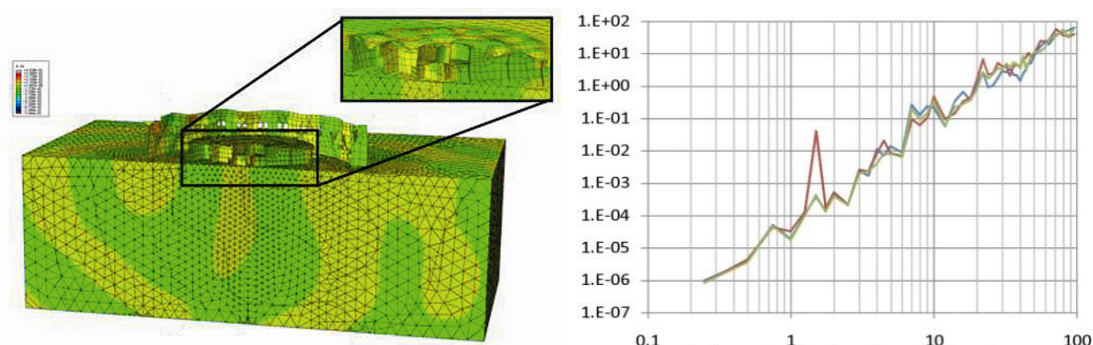

Figure 3.33. Model for the calculation of the transfer function from the dome bogies to the telescope foundations and transfer function in units of ms^{-2}/m vs. Hz.

Two major components are considered for the source of vibrations from the dome itself: the smoothness of the track and the wind loading that would produce vibrations transmitted through the track. The roughness of the wheel and rail interface is a vibration and noise source and applicable standards from

the railway industry exist. Assuming the applicable International Organization for Standardization (ISO) norms for the tracks, the resulting accelerations at the telescope pier exceed the specification at high frequencies for tracking speeds close to a quarter of a degree per second. At higher speeds (presetting 2 degrees s^{-1}) the vibrations exceed the specification above 20 Hz.

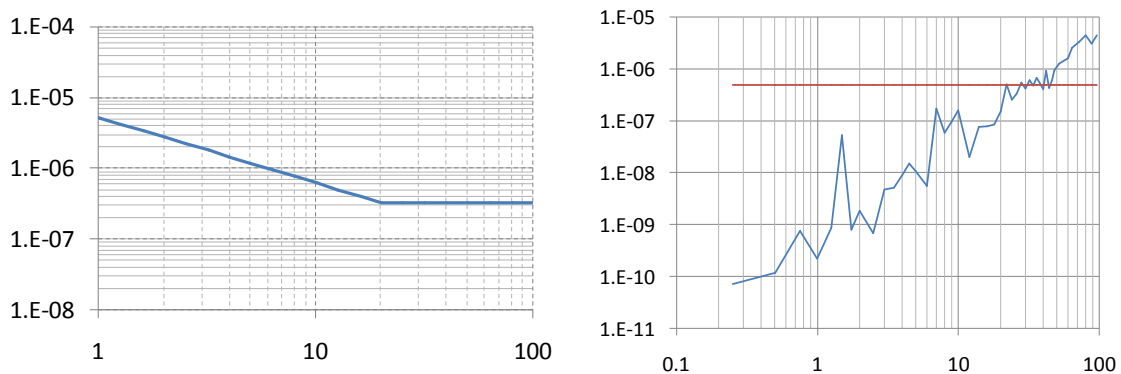

Figure 3.34. Track smoothness in m vs. Hz (rotational frequency) and acceleration per square root of frequency vs. frequency ($g/\sqrt{\text{Hz}}$ vs. Hz).

The vibrations from the track rotation are largely compliant and can easily be improved by careful machining of the tracks and track maintenance. Elastomeric pads can be placed below the azimuth rotation bogies to reduce the coupling of the bogies to the dome concrete.

The part of the dome exposed to the wind will also shake and the vibrations are transmitted through the bogies along the same path analysed above. The wind analysis has taken the maximum operational speed of 18 ms^{-1} and used a rear of the dome exposure to the wind direction thereby reflecting the foreseen operational condition and providing the least aerodynamic exposure of the dome to the wind. A von Karman spectrum for the wind has been used with a 15% turbulent intensity. The vibrations due to the wind transmitted to the main structure lie two orders of magnitude below the $0.5\text{-}\mu\text{g}/\sqrt{\text{Hz}}$ requirement.

During telescope operation, with the exception of the large air handling units, the bulk of the machinery remains in operation. As almost all the equipment is driven off the same mains power supply, the vibrations are assumed to be in phase. The analysis of this source of vibration has used the resonant frequencies expected for the equipment rather than a Power Spectral Density (PSD). To achieve the acceleration spectrum the isolation system shall have an efficiency of 98%. Particular attention is paid to the pumps that re-circulate the chilled medium and the air handling units that keep the azimuth rotation chamber cool. To limit the vibrations in the piping, flexible connections and suspended piping are foreseen. Additionally, expansion tanks are planned to avoid the propagation of pump vibrations along the column of chilled medium.

3.2.9 ACCESS AND MAINTENANCE

The dome provides utilities to the telescope with the dome crane, the dome auxiliary crane and the dome lifting platform. The 20-tonne dome crane is embedded in the observing door arch and therefore accesses the bulk of the telescope volume. The dome auxiliary crane is a 20-tonne jib crane mounted on the secondary structure of the dome. It provides easy access over the Nasmyth platforms of the telescope.

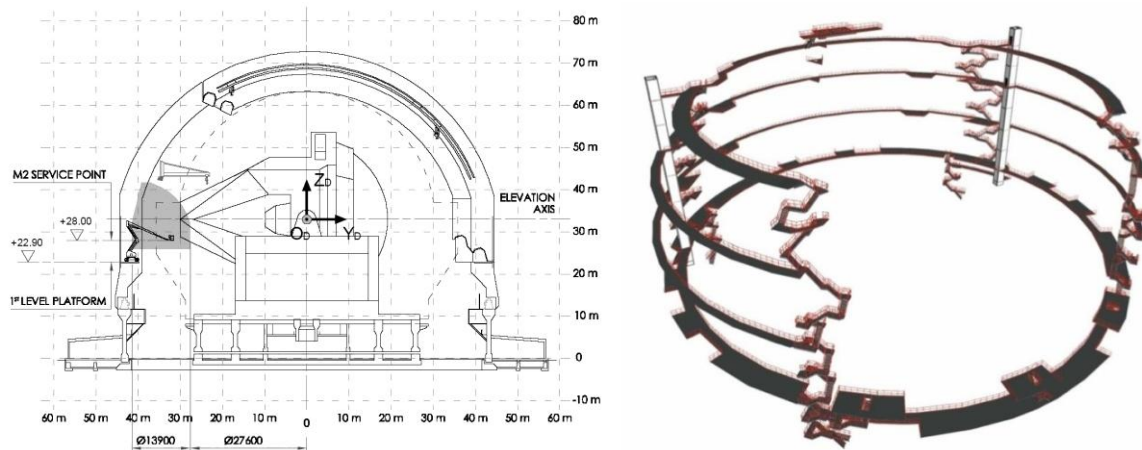

Figure 3.35. Access for the secondary mirror unit (left) and walkways inside the dome (right).

The cladding and upper door mechanism access is provided via the walkways, ladders and elevators mounted as part of the dome secondary structure. The dome drives can be accessed directly from beneath the base ring. Specific tooling will be needed if a whole bogie is to be exchanged although they are not considered to be Line Replaceable Units (LRUs).

3.2.10 MASS BUDGET

The following tables show the mass budget of the dome and foundations:

Fixed parts:

Item	Description	Mass (in tonnes)
Dome foundations	Concrete walls and slabs	15 725
	Concrete floor	1 560
Telescope foundation	Concrete walls and slabs	17 815
	Concrete floors	794
Access structures and equipment	Steel structure	392
	Access structures	117
Auxiliary building (including main entrance)	Concrete	5 848
	Concrete floor	1 416
	Steel	377
	Cladding	168
Azimuth bogies		805

Table 3.1. Mass budget for fixed parts of the dome and foundations.

Moving parts:

Item	Description	Mass (in tonnes)
Dome azimuth rotating part	Primary structure Secondary structure Access structures Walkways slab Azimuth track Dome cladding Door tracks Main crane Auxiliary crane	3329
Slit doors	Left	398
	Right	436
Windscreen structure	Structure Mechanisms	593

Table 3.2. Mass budget for moving parts of the dome and foundations.

3.2.11 ERECTION SEQUENCE

The dome erection sequence has been analysed by the designers and, in addition, two external suppliers (DSL and Demont) have provided independent analysis of a probable erection sequence and schedule. All suppliers have slightly varying sequences and different tooling based on their particular experiences.

The delivery of the equipment to the site is considered to be by ship to the port of Mejillones and from there by truck to the lay-down areas at the summit and basecamp of the observatory.

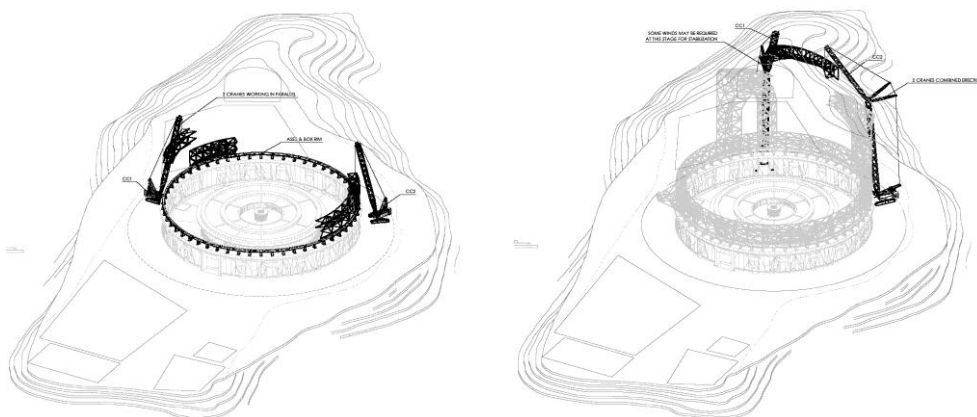

Figure 3.36. Selected images from the erection sequence of the dome.

3.2.12 EARTHQUAKE ANALYSIS

A detailed analysis of the dome structure in case of earthquake has been performed. Both quasi-static and dynamic analyses have been performed.

The structure has been verified to be able to withstand the peak ground accelerations specified in the environmental conditions without damage. Additionally the baseline solution for the dome includes a seismic base isolation system based on lead rubber bearings located at the foot of the dome and telescope pier.

Several analyses have been carried out to investigate the performance of the dome isolation system under the No-Collapse Requirement (NCR) conditions.

The seismic isolation units provide an equivalent 27% damping and shift the fundamental frequency of the building to 0.51 Hz, therefore no longer coupling the stiff sections of the dome structure above to the high accelerations of the earthquake. For this frequency, the horizontal acceleration experienced by the structure is reduced to 0.14g obtained from the NCR response spectrum and assuming 27% damping of the isolation system.

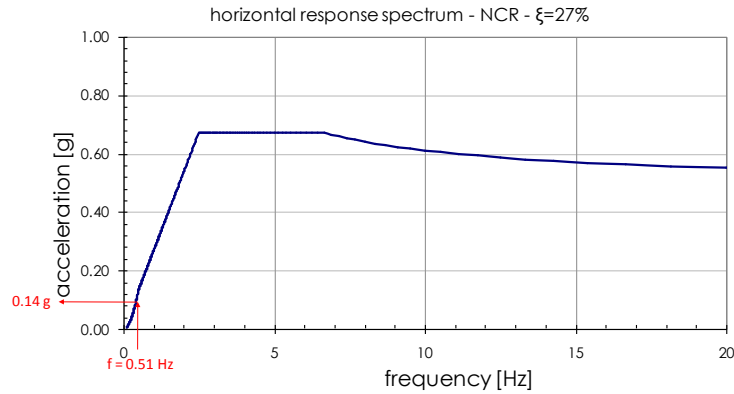

Figure 3.37. Effect of seismic isolation system on the accelerations experienced by the structure.

The maximum loads and displacements of the dome foundations, the auxiliary building and the dome foundation isolators do not exceed the allowed values. The strength verification of the dome structure was carried out for the upper bound of stiffness and lower bound of damping, because this is the most unfavourable case for dimensioning the structure. The telescope and its subunits are designed to deal with an earthquake that would couple with the main structure at above 1g acceleration. The use of seismic isolators would reduce the exposure of the system significantly. However, this does not imply a change in the design of the hosted units. The usage of seismic isolation would only engage at larger earthquakes and therefore relatively minor, for the region, events would be felt by the structure directly. This process ensures that the necessary stiffness of the pier for the telescope is maintained in routine operations. The optimum threshold value for the activation of the seismic isolators will be defined to be above the operational loads and below the critical earthquake loads both with sufficient margin.

The use of such isolators is nowadays common in high seismicity areas.

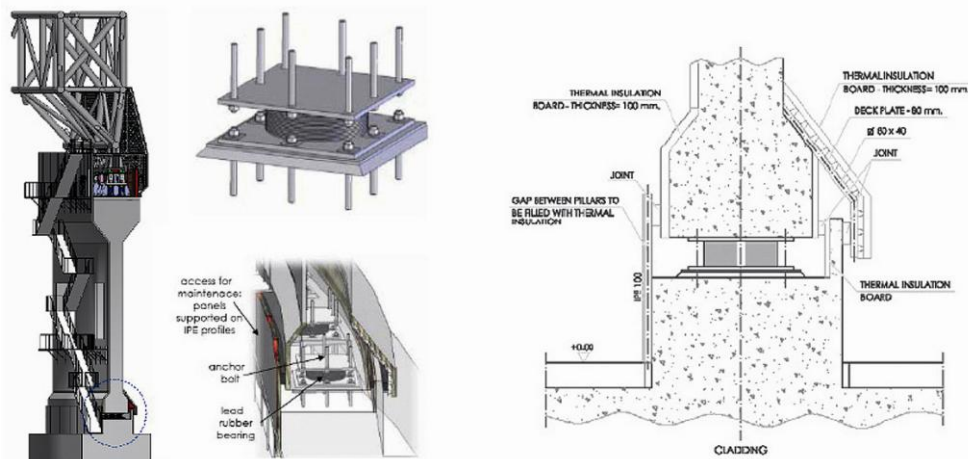

Figure 3.38. Location of the dome seismic isolators.

The erection sequence has considered earthquake accelerations in evaluating the shoring necessary in the temporary structures.

3.2.13 WIND LOADING AND WIND FLUSHING OF THE TELESCOPE CHAMBER

To assess the wind loading for the structural design of the 39-metre dome, a boundary layer wind tunnel study has been done. It covers the main configurations of the dome: door closed (survival configuration) and open (operation configuration). Several test scenarios were conducted as part of the wind tunnel study: the azimuth angle of the dome, the position of the windscreen (deployed or undeployed) and the louver window configuration (closed or open). The test scenarios and the dome model for the wind tunnel study are shown in Figure 3.39.

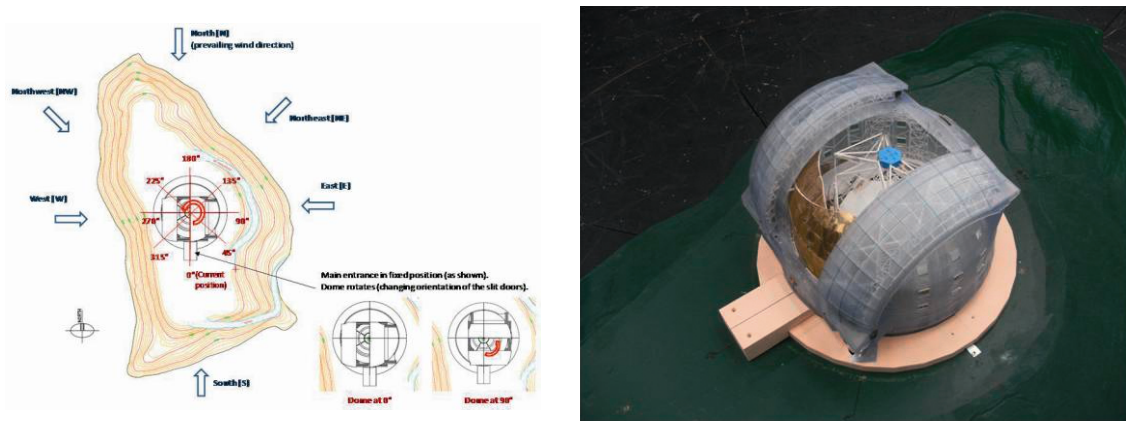

Figure 3.39. Test scenarios and the dome model for the wind tunnel study.

The wind properties applied were based on the Armazones environmental conditions. The results were obtained as a worst case equivalent pressure distribution. Figure 3.40 shows the worst case equivalent pressure distribution for one load case. The pressure distribution was included in the finite element model, but the wind loads are less restrictive than the seismic loads for the dimensioning of the structure and the mechanism.

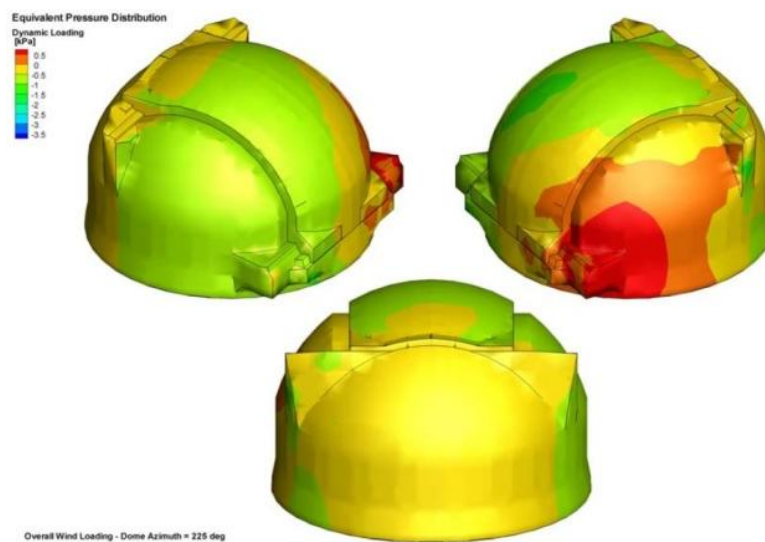

Figure 3.40. The worst case equivalent pressure distribution for one load case.

The wind flushing study of the telescope chamber shows the mean wind speed, the turbulence intensity and the time history curves of the velocity measurement. Therefore the air changes per hour can be measured. These studies were done for different configurations. The measurements of the air change rates were made using an array of aspirating probes with their receptors mounted directly inside the dome. There is a clear conclusion for the foundation louvers: closing the foundation louvers reduces the number of the air changes per hour appreciably. Therefore it was decided to include the foundation louvers in the design.

3.2.14 RELIABILITY AND OPERABILITY

The fire safety analysis, acoustic analysis, lightning protection, electrical systems, electromagnetic capability analysis, safety analysis, air handling equipment design and chilled water stress analysis all support the conclusion that the dome, while complex and large, can be constructed and operated with reasonable resources.

3.2.15 ALTERNATE SUPPLY FOR THE DOME

Two alternative designs for the dome have been evaluated during the design phase. The design by ARUP was established at the preliminary design level and offered to the FEED suppliers in parallel with the IDOM design. The second FEED contractor, EIE/Cimolai, has established a variant of the preliminary design supplied to the contractors and completed their FEED study. A complete set of the documentation is also delivered but will not be cited here.

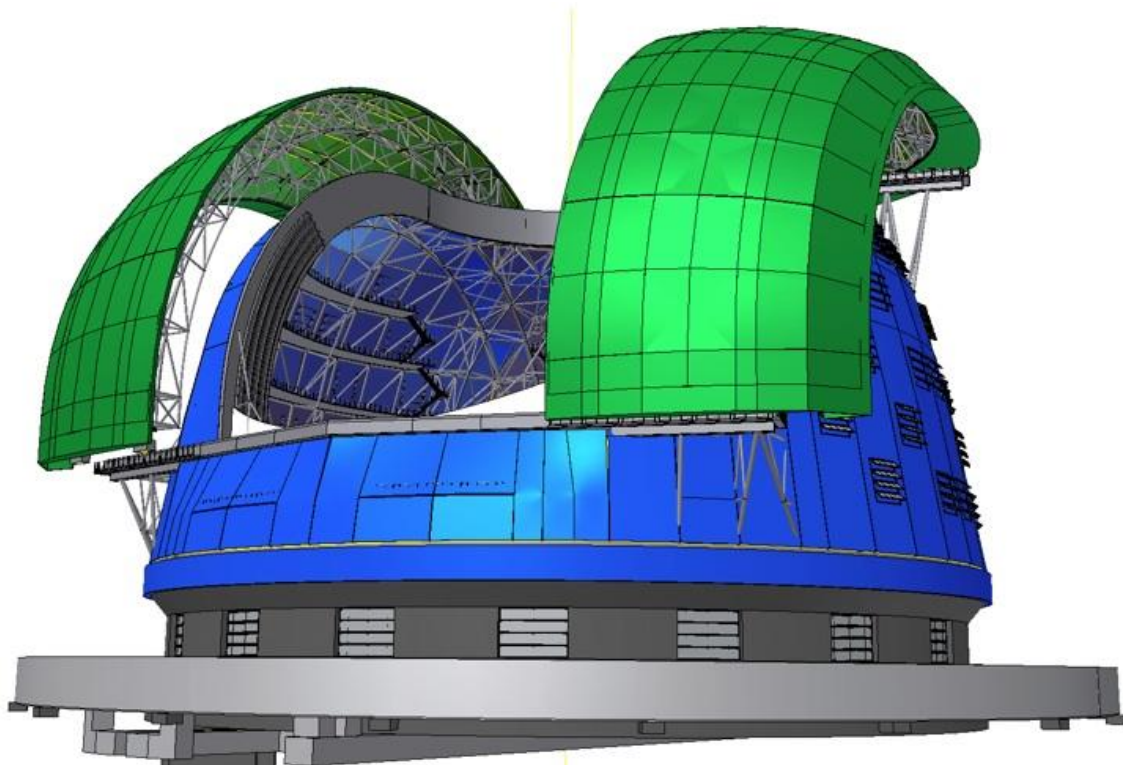

Figure 3.41. EIE/Cimolai alternate dome FEED design.

The design provides variants on a number of components and in particular on the windscreen design that is based on carbon-fibre blades. Additionally, the erection sequence of EIE is based on the experience of their partner Cimolai in lifting structures from below rather than with large cranes.

3.3 MAIN STRUCTURE

The E-ELT main structure (telescope mount) provides for coarse pointing and tracking (approx. 1 arcsecond root mean square (rms) and 0.1 arcseconds rms respectively). As per the control scenario, the fine alignment of the optics and the beam steering is done by the optical element control.

The main structure design delivers a lowest eigenfrequency of 2.9 Hz. In combination with a number of other requirements, for example on pointing and tracking specifications, the designers are constrained in providing the critical performance needs for the main structure. As part of the control strategy, the main structure needs to be able to track sufficiently well under wind loads such that the M4 and M5 units can absorb any residuals, both in amplitude and frequency.

The movement of the secondary unit with respect to the primary, both statically and dynamically, is also a potential major source of wavefront error. The design of the upper support of the telescope limits both the amplitude and frequency of the M2 unit deflections.

The performance of the primary mirror cell determines the total actuator stroke used to position the segments. The dominant source of error for the telescope cell is gravity. The deflections enter into the error budget by introducing low order aberrations and in the stroke budget.

Thermal deflections are low by comparison to gravity.

3.3.1 CONCEPT

The design has evolved during the phase B and is now set on a 39-metre diameter telescope, based on the main concepts presented in the 2010 construction proposal. The telescope is an alt-azimuth mount based on a rocking-chair concept. Two massive cradles provide the rotation of the altitude axis while two azimuth tracks take the axial loads and allow the rotation of the telescope about the zenith. The cross azimuth platform is used to provide access to the hosted units for exchanges.

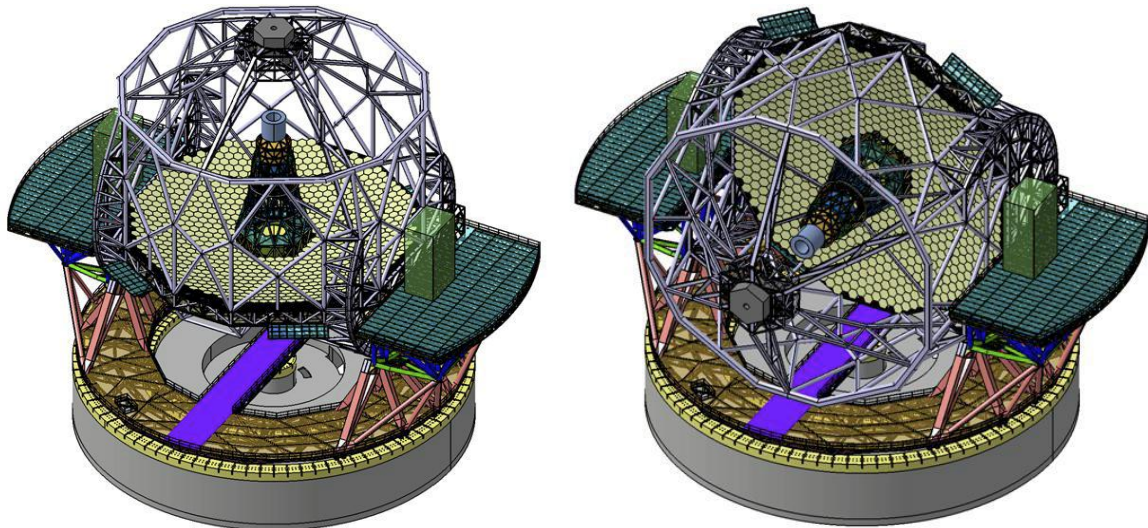

Figure 3.42. The main structure at zenith pointing and horizon pointing.

Axial and radial hydrostatic bearings and direct drive motors form the baseline for the design.

The challenge in such a massive design is to provide a stiff enough interface for the primary mirror segments while at the same time not dramatically increasing the weight of the structure or overcomplicating the support (e.g., multiple cradles).

3.3.2 AZIMUTH STRUCTURE

The azimuth structure is based on a two joined rings that ride on hydrostatic bearings on the two azimuth tracks at diameters of 34 metres and 51.5 metres that form the baseline interface to the telescope pier.

The azimuth structure, excluding Nasmyth platforms and floors, weighs 1288 tonnes. The structure is made of hollow beams of various sections which optimise mass while retaining stiffness.

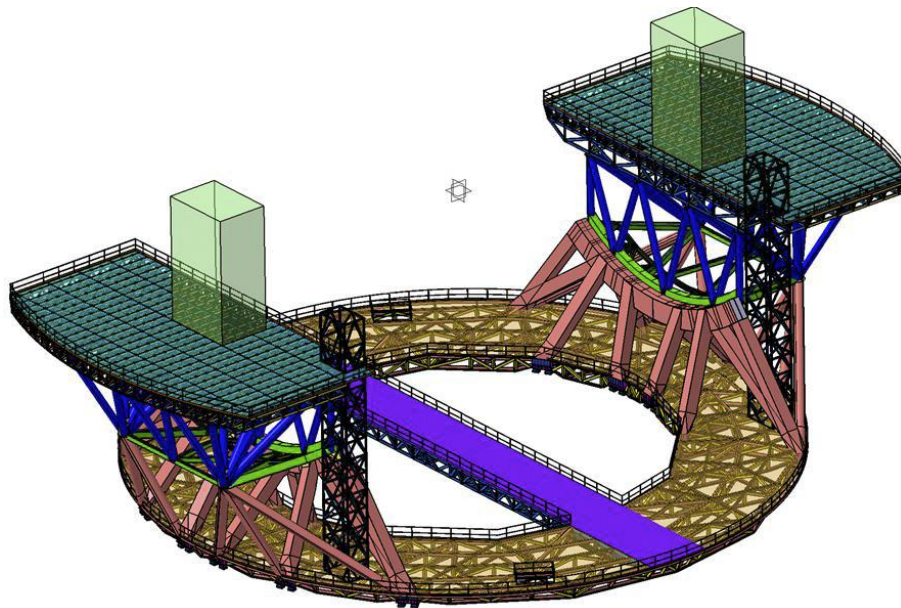

Figure 3.43. The azimuth structure and the floor for extracting hosted units.

The azimuth floor encompasses a gateway that crosses over the centre of the pier to carry the hosted units out of the main structure.

The tracks at diameters of 34 metres and 51.5 metres and one central pier take the axial and radial loads.

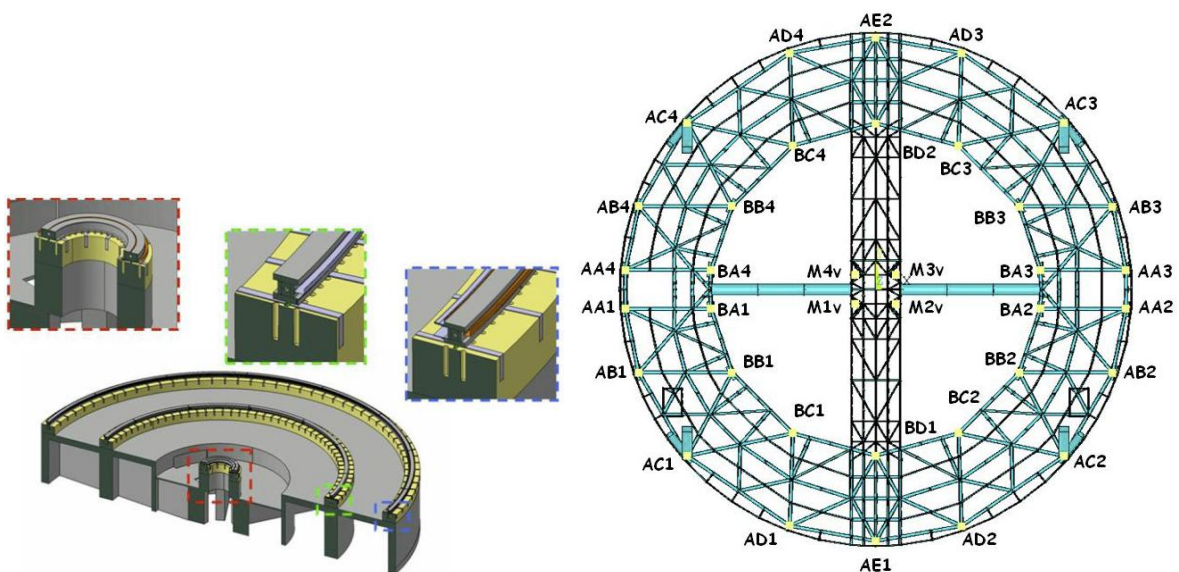

Figure 3.44. The azimuth rings and arrangement of the support points for the azimuth structure.

Axial hydrostatic bearings placed in 36 positions under the three tracks supporting the main structure.

The axial pads are concentrated around the most loaded areas (below Nasmyth platforms — positions AA, AB, BA, AC and BB — with pad supports), as the other locations (positions BC, AD and AE — with single pad supports) have a lower contribution.

The load distribution is based on static hydraulic chambers pressure control, the exact strategy depending on detailed design.

A finite element model of the track reveals the need for tight stiffness optimisation of the tracks during detailed design in order to minimise deformations during operations.

Worst case simulations (thermal, wind, gravity and worst earthquake combined loads) show that admissible stresses stay below 90% of the material yield limits. For operational loads, the equivalent operational figures for wind, thermal and earthquake loads are used and the admissible stresses stay below 67% of the yield limits.

The 34-metre diameter track is used for the radial constraint using 24 supports of equally distributed pads (typically single ones).

Four radial bearings in the central 4-metre ring support are used to define the azimuth axis during the on-field machining phase for the inner and outer tracks for which altitude cradles are needed. These hydrostatic bearings are later decoupled from the track or dismantled. The baseline radial pad design is spring-loaded (120 kN nominal + 30 kN spring) during operations to compensate for track radial run out and to incorporate a friction interface limiting the maximum allowable load in case of earthquake until the seismic stops actuate.

3.3.3 THE NASMYTH PLATFORMS

The two Nasmyth platforms are mounted on the sides of the azimuth ring.

Their carrying structures are the base for the support of the altitude cradles. The standalone Nasmyth structures do not provide any buttressing for the telescope altitude structure. The Nasmyth platforms host the pre-focal stations and provide stable platforms for the post-focal instrumentation.

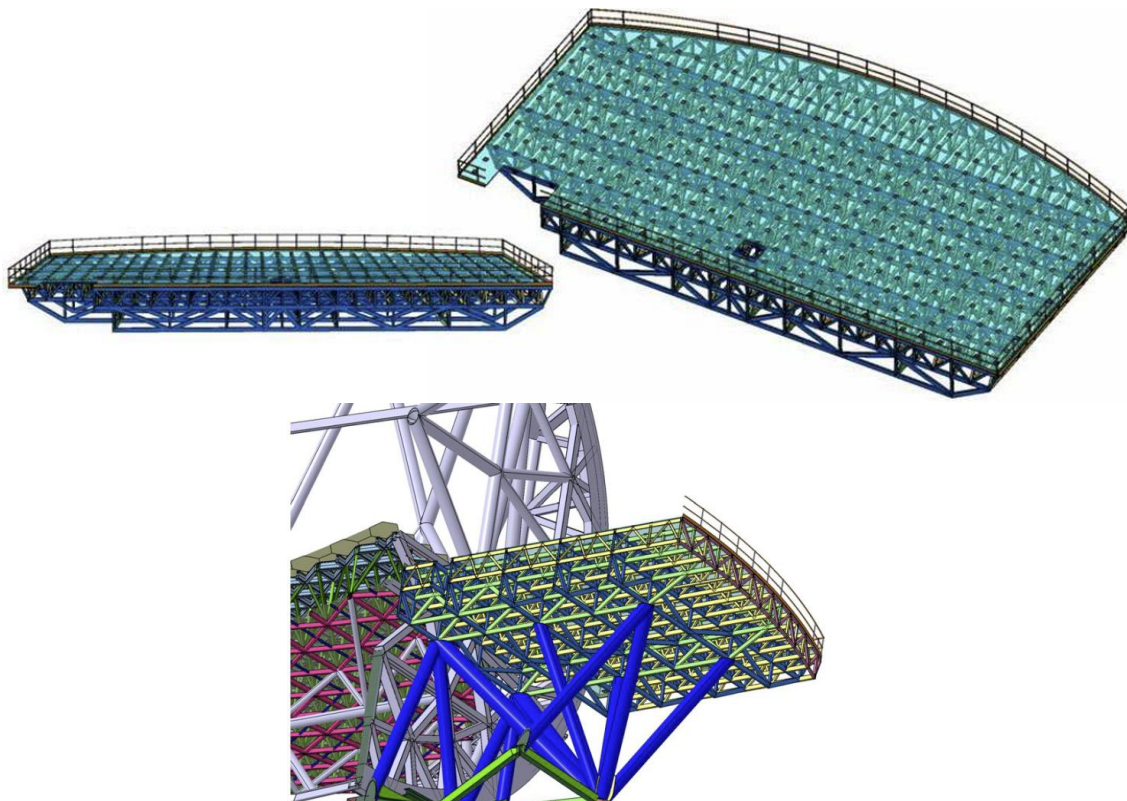

Figure 3.45. View of the structure of the Nasmyth platform.

The pre-focal stations are expected to weigh 28 tonnes each. Each platform carries 98 tonnes when fully loaded with pre-focal station and full instrument capability. The static deflections of the Nasmyth platform can be compensated by other static means (e.g., shims) or pointing terms. The dynamic behaviour of the platforms forms part of the interface to instrumentation that may be mounted directly on the platform rather than on the rotators of the pre-focal station. The deflections of the Nasmyth platform interface for

instrumentation relative to the pre-focal station are considered too high to permit instrument exchanges without re-alignment. The analysis however shows that the installed instrumentation will be able to cope with small adjustments to its pointing solutions rather than a complete re-alignment when other instruments are located on the platform. Instruments hosted directly on the Nasmyth, and using their own de-rotators, will need to provide their own slow guiding capabilities to correct the changes between the telescope pointing and their mounting on the Nasmyth platform.

The azimuth structure also provides interfaces for the coudé train mirrors and has volume provisions for the installation of either an evacuated or open coudé train. The optical design of the coudé train is part of the instrumentation.

3.3.4 ALTITUDE STRUCTURE

The altitude structure hosts the telescope optics. The major challenges that have been addressed in the design are the need to keep the primary mirror segments within a reasonable range from their prescribed locations and the need to minimise the deflections, both static and dynamic, of the secondary mirror. The minimisation of the deflections of the primary mirror cell is a key metric for the design of the altitude structure. The total weight of the altitude structure without the hosted units and mirror cell is 1498 tonnes. It is almost entirely assembled from steel tubular sections with a variety of diameters.

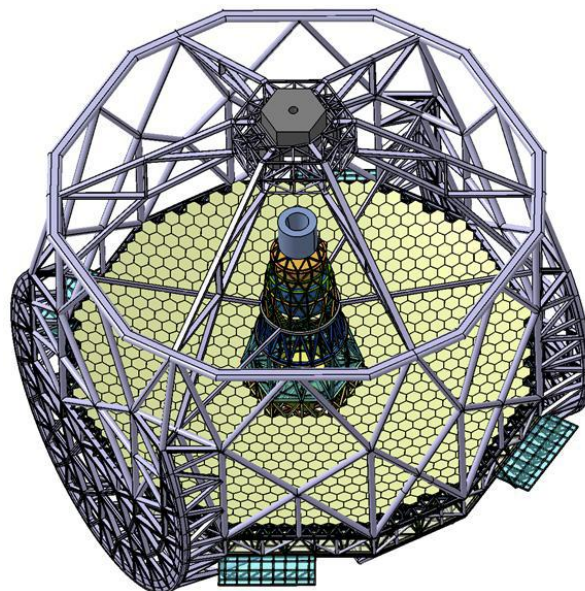

Figure 3.46. The altitude structure of the telescope.

The two large cradles are supported by radial and lateral hydrostatic bearings.

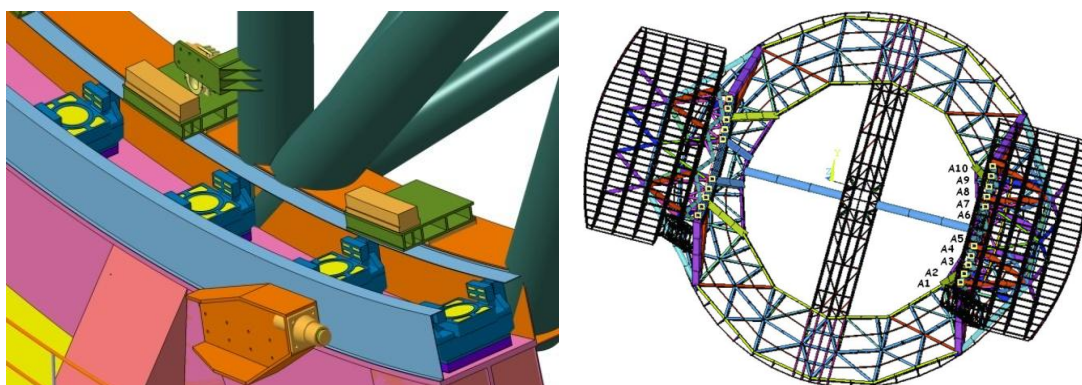

Figure 3.47. The altitude support assembly and identification.

Each cradle has ten locations of identical supports encompassing one radial and two lateral hydraulic pads. The pads are mounted on a common structure and in close proximity to the motor segments. The analysis shows that in this configuration, in spite of some deflections of the structure, the nominal motor gaps of 2.9 mm can be maintained within operational tolerances.

3.3.5 HOSTED UNITS

The telescope will provide to all hosted units network, power, cooling and compressed air supplies as needed via one or more service connection points (the VLT-type concept).

The needs of each unit are to be found within their descriptions in the relevant chapters. As a matter of strategy, each unit has been required to minimise its demands on cooling. This reduces the risk of leak-ages.

The primary mirror cell provides a mechanical interface to each of the segment units. The location of these interfaces is considered to be true to ± 5 mm at the time of erection of the structure.

The more accurate alignment, necessary for the installation of the segments, will be performed using dedicated dummies that will reflect the correct loading and distribution on the structure. The interfaces for cooling and network will depend on the final solutions chosen for the primary mirror control system. It is not expected that the primary mirror cell will require a compressed air supply.

The mirror cell is made in a single layer with a floor that permits air circulation and provides for standing human access to all locations under the cell.

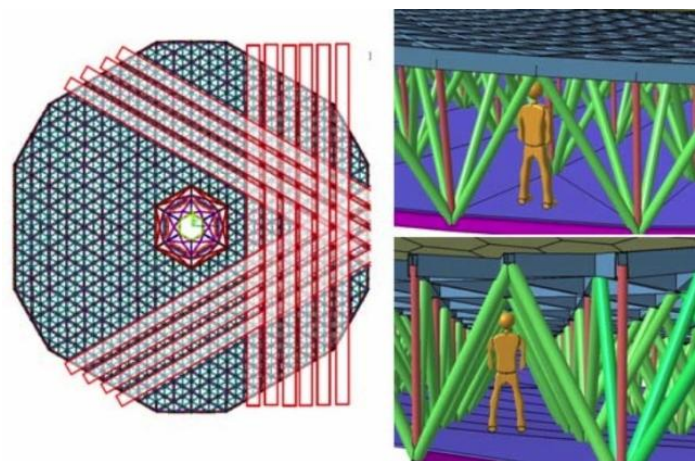

Figure 3.48. The telescope mirror cell structure.

The primary mirror cell also provides the interface for the tertiary mirror cell at its apex, and the interface for the central tower that hosts the quaternary and M5 mirror units.

The large central obstruction of the optical design also provides ample room for the erection of the central tower. There is no dedicated interface for the tower as it forms an integral part of the main structure.

Four spider arms support laterally the tower at M3/M5 crane level and allow 20% dynamic behaviour improvement. At the top of the tower, the M4 unit is hosted.

The baseline design assumes that M4 will be mounted on a rotating stage with a hexapod for fine alignment. Both of these functions are part of the M4 unit and the main structure provides a stiff interface against which the unit is mounted. The specifications for both M4 and M5 are such that a single 8kW service connection point will suffice for cooling and other services.

Above the M4 unit, an interface provision for a full-field Atmospheric Dispersion Compensator (ADC) is provided. Immediately below the M4 unit there is an interface provision for optomechanical devices

wishing to access the $f/4$ intermediate focus (e.g., calibration sources for adaptive optics systems, polarimetric modulators).

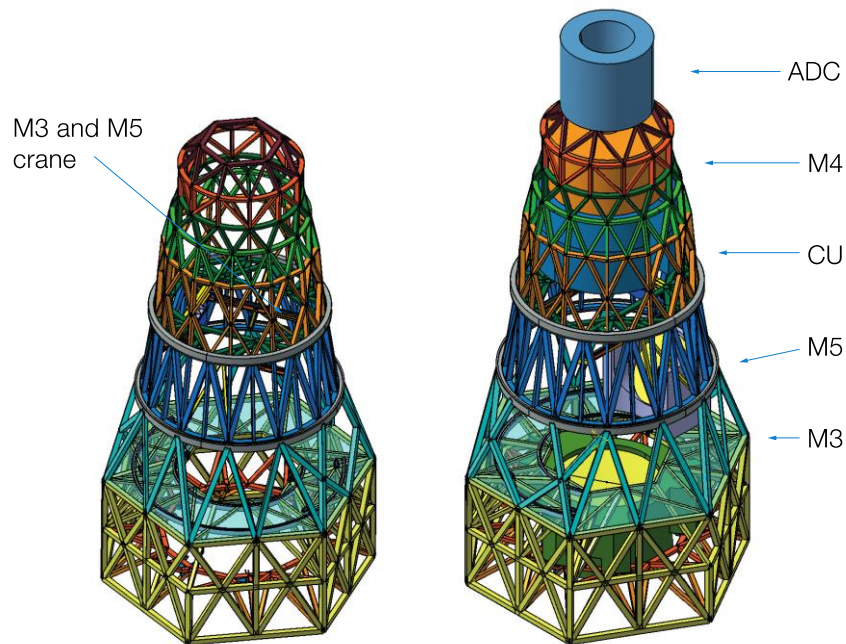

Figure 3.49. Adaptive relay tower with and without hosted units (volumes).

On the tower below the height of the altitude axis, a bearing is mounted that allows the rotation of the M5 unit.

The rotation of the M5 unit, aiming to select one of the two Nasmyth locations, is part of the main structure. The repeatability requirements in the α -Alt, β -Alt and γ -Alt angles is ± 0.5 arcminutes while the repeatability in the X-Alt, Y-Alt and Z-Alt axis is ± 0.5 mm.

In the 39-metre design, the balancing and stiffness performance of the M2 supporting can be achieved with a mild steel structure.

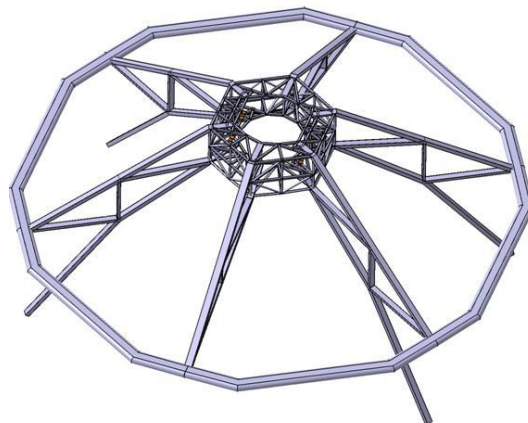

Figure 3.50. The spider and secondary mirror crown.

On the periphery of the M1 mirror cell, there are four locations where launch facilities and laser units can be located. The mechanical interface is relatively simple as the launching units have provisions for correcting for pointing differentials between them and the telescope (see Section 3.10).

3.3.6 MODELLING THE STRUCTURE

The behaviour of the entire telescope under conditions deemed critical has been simulated for the 39-metre baseline. The model used retains the bulk of the finite element modelling, the optical sensitivity matrix and details of the control system for the main structure. The output of the modelling is used to validate the requirements and the design choices.

The predominant eigenfrequencies and modal masses of the telescope structure when pointing to zenith and horizon are listed in the tables below. The first eigenmode (locked rotor) is found at 2.9 Hz with the telescope pointing to zenith, reducing to 2.5 Hz for horizon pointing.

Mode	Frequency [Hz]	Effective mass [%]						Mode shape
		X	Y	Z	R_x	R_y	R_z	
1	2.91	0	53.7	0	7.3	0	0	Locked rotor
2	3.19	76.5	0	0	0	0	0	Cross-elevation
3	3.99	0	0	0	0	0	4.2	M2 spider rotation
4	4.45	0	38.3	0	56.8	0	0	Second locked rotor
5	4.74	0	0	0	0	0	50.3	Azimuth rotation
8	5.17	0	0	21.7	0	0	0	Vertical pumping

Table 3.3. Eigenfrequencies and effective modal masses for the telescope pointing at zenith.

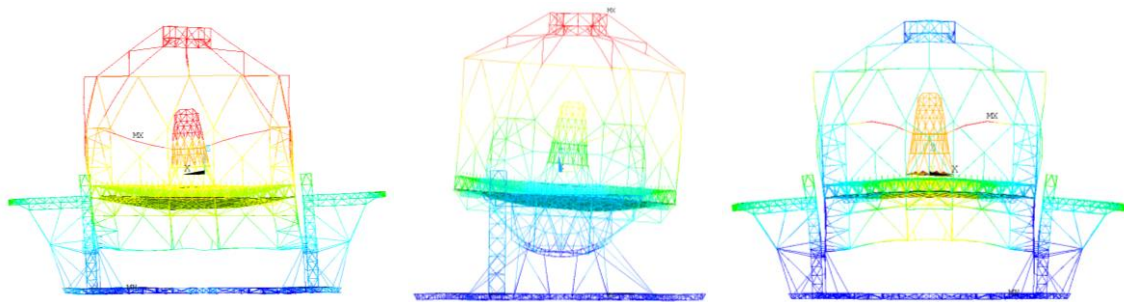

Figure 3.51. Mode shapes for pointing to horizon: modes 1 (2.9 Hz), 2 (3.2 Hz) and 8 (5.2 Hz).

Mode	Frequency [Hz]	Effective mass [%]						Mode shape
		X	Y	Z	R_x	R_y	R_z	
1	2.50	0	45.5	0	10.7	0	0	Locked rotor mode
2	3.26	75.1	0	0	0	0	0	Cross-elevation
3	4.03	0	0	0	0	0.5	0	M2 spider rotation
4	4.20	0	41.4	1.3	50.9	0	0	Second locked rotor
5	4.40	0.3	0	0	0	0	48.7	Azimuth rotation
18	7.11	0	0	21.7	2.4	0	0	Vertical pumping

Table 3.4. Eigenfrequencies and effective modal masses for the telescope pointing at horizon.

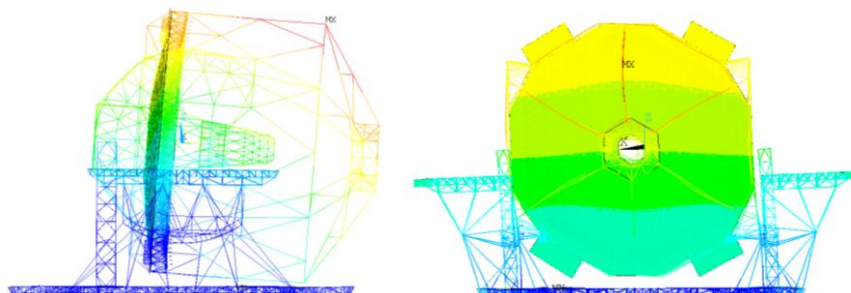

Figure 3.52. Mode shapes for pointing to horizon: modes 1 (2.5 Hz) and 2 (3.3 Hz).

The structure provides the required stiffness at the mounting locations of hosted mirror units.

3.3.6.1 THERMAL EFFECTS

The effects of differential temperatures on the structure have been analysed. In the case of a gradient of around 3°C along the Y-axis of the structure the displacements of the hosted units remain below 0.5 mm except for M2 (0.51 mm) and the rotational deviations are 2.6 arcseconds in the primary mirror units and 6.1 arcseconds for the secondary mirror, a rotation about the X-axis (joining the altitude cradles).

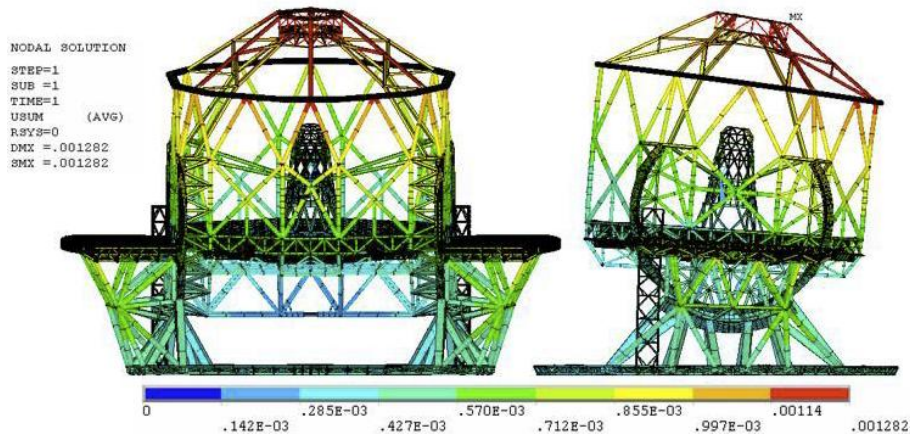

Figure 3.53. Displacement due to a temperature gradient of $0.05^{\circ}\text{Cm}^{-1}$ along y.

For a gradient of around 6°C along the Z-axis the variations are all reasonably small with displacements of less than 2 mm.

3.3.7 VIBRATIONS

The 39-metre telescope version is expected to behave in a similar way to the 42-metre version which, following analysis, was shown to have an acceptable stability performance.

Confirmation of this assessment will be verified before the construction phase.

3.3.8 DRIVES, ENCODERS, METROLOGY

The baseline design uses direct drive motors. For azimuth, the stators are mounted on the 51.5-metre track, while the coils are attached to the moving structure. The altitude axis inertia is $2.9 \times 10^8 \text{ kgm}^2$ and the inertia around the azimuth axis is $1.13 \times 10^9 \text{ kgm}^2$.

The motor torque allocation is 577 kNm continuous and 3708 kNm non-continuous for the azimuth axis and respectively 605 kNm and 2084 kNm for altitude, including a 10% margin.

Twenty-four axial single gap coil sections compose the direct drive motors for the azimuth and 16 single cylindrical gap coil sections compose the motors for altitude (eight on each side).

The balanced single gap configuration on azimuth and altitude allows cost reduction and is viable if motor coils are co-located with stiff points (i.e., hydraulic bearing pads) for tight air gap control.

The baseline design for the altitude axis uses co-located encoders (located on cradles near the drive system) to provide position and velocity information to the drive control system. The past experience of ESO at the VLT has been very positive in this respect. The co-location allows the use of the encoder as a digital tachometer and removes what, in the experience of ESO, has been a significant source of noise in the control of the main axes of telescopes.

A rough absolute position measurement is implemented, in addition to the fine incremental one, in order to allow axis initialisation in small displacements and increased redundancy in position knowledge.

For azimuth, the studies and analysis show that the installation of the encoder system at the 34-metre track has nearly the same properties as co-locating and hence it is a good compromise between feasibility/cost (encoder tape length) and performance.

The exact design of axis position measurement will have to be detailed/refined in order to optimise technology choices versus performance/price and operational robustness requirements.

3.3.9 CABLE WRAPS

Two altitude cable wraps are provided for, one on either side of the telescope. They have 0.2 m² of available cross-section, of which 20% is reserved for future cabling needs. The minimum bending radius is 1.2 metres. The location of the altitude cable wraps is on the side of the pre-focal stations.

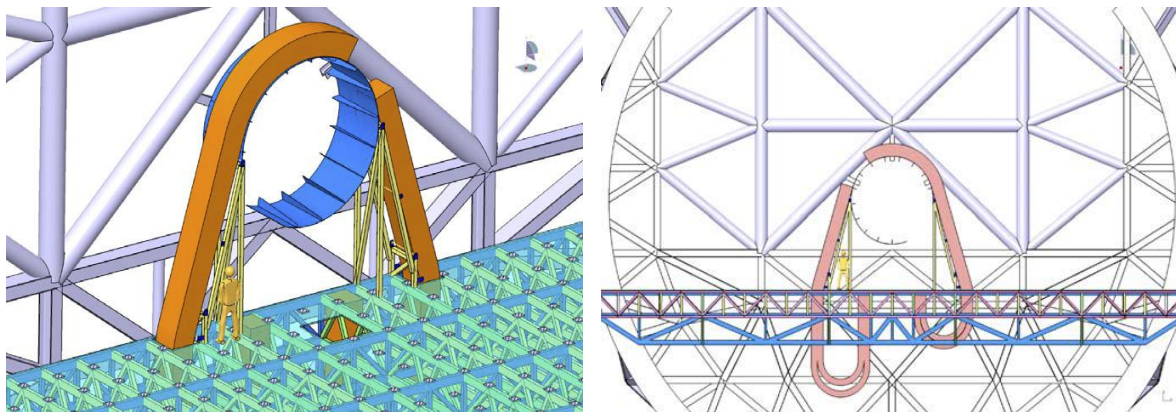

Figure 3.54. Altitude cable wrap.

A normal chain link cable container is placed on guide rails.

The azimuth cable wrap is located within the central pier of the telescope foundations and provides 0.15 m² of available ducting with the same provisions for free space and similar bending radii as for the altitude wrap.

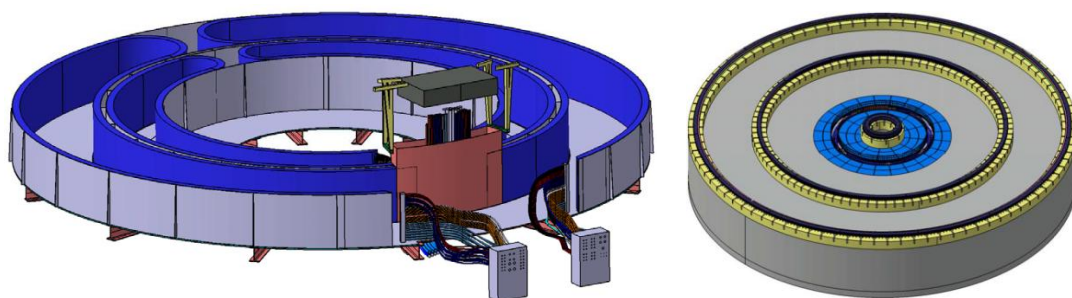

Figure 3.55. Azimuth cable wrap dual kinematic chain and location with respect to the tracks.

3.3.10 WIND

The analysis of the telescope behaviour under wind loading has adopted the exposure figures determined in the wind tunnel experiments. Specifically the secondary mirror sees a 20% reduction in wind speed relative to the external conditions and the primary mirror one sixth of the external wind.

The analysis was then performed assuming a 10 ms⁻¹ external operational wind speed.

The worst case is at a 45-degree altitude position, for which maximum rigid body displacements are within required values, with a wind tunnel test confirming the conservative approach of the analysis. The corresponding maximum displacement of M2 along the altitude Y-direction is 0.23 mm and the rotation about X-axis is 1.34 arcseconds.

3.3.11 PERFORMANCE OF THE MAIN STRUCTURE

The telescope main structure has interfaces to almost all subsystems of the observatory. Each of these interfaces can be considered a performance issue and indeed impacts the design. The design largely respects these interface-related performance (stiffness, maximum deflections etc.) requirements. In this section we only consider the context of pointing and tracking behaviour of the main structure.

The deflections of the telescope main structure under gravity and the static components of loads such as wind are significant. A basic pointing solution based on the alignment scenarios can be considered to be viable. The altitude and azimuth of the main structure will point with an accuracy of order a couple of arc seconds on the sky[§]. For the purposes of the telescope this performance is largely irrelevant as the dominant error in pointing comes from the static deflections of the optics and not the actual position of the axes. The absence, or very low levels, of hysteresis in the system are important in establishing the necessary models.

The tracking performance is important to the extent that the bandwidth of the local control is sufficiently high that it can act as an offload channel for the rest of the control. The first eigenfrequency of the main structure is a very respectable 2.9 Hz. Control simulations show that the enormous inertia of the telescope combined with the relative stiffness result in tracking errors on the main axes of approximately 0.25 arcseconds rms.

The dominant dynamic disturbance is the wind. The performance simulations are made for a frontal 10 ms⁻¹ external wind that in exposed elements is reduced to 8 ms⁻¹ while for elements behind the wind-screen is reduced to below 2 ms⁻¹. Additionally a simulation using a 20-degree angle of attack is used to investigate non-symmetrical effects of the wind, the tracking errors on the azimuth axis and consequently the wavefront tip.

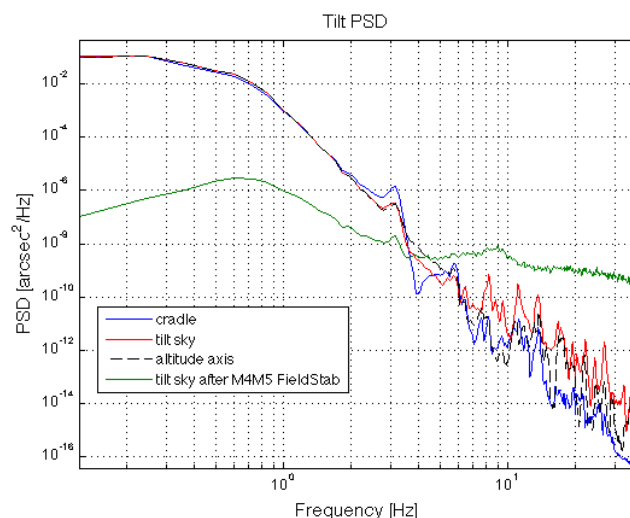

Figure 3.56. The PSD of the tracking error on the cradle encoder (blue) and the tilt error on sky (red). A virtual central encoder is also modelled.

The large part of the tilt error is due to rigid body motion of the altitude around its axis (as can be seen from power spectral density responses of encoder and tilt) up to 2 Hz. There are contributions (smaller amplitudes) due to the deflection of the structure and the mirror, which can be observed on tilt PSD for higher frequencies.

The contribution of each mirror to the final tip-tilt on the sky has been analysed in the simulations.

[§] This is already the case at the Unit Telescopes of the VLT, where a collimation sequence is performed automatically by the control system at the end of the preset sequence. Without this the pointing would be poor and conditional on previous history, and the control system significantly more complex.

Other aberrations are also introduced when the optics are out of alignment.

The simulations have also analysed the need for co-location of encoders, effects of cogging/ripple torque, encoder quantisation and periodic errors, and sampling/delays in the system. Particular attention has been paid to the potential coupling of the ripple torque to the control. At high speeds the ripple torque from the motors can couple into eigenmodes of the telescope. This effect has been analysed for the former baseline design and is considered possible only at high azimuth tracking speeds very close to the zenith. In addition, the impact on the wavefront error (tip) turned out to be small but is considered in the error budget of the actual baseline design.

The analysis shows that the main structure system can achieve a 1 Hz closed loop bandwidth (with cascaded velocity and position loops) on both the altitude and azimuth axes with a residual tip-tilt error of order 0.25 arcseconds on the sky resulting almost exclusively from windshake.

The effect of artificially reducing the bandwidth increases the error on the sky almost linearly with 0.5-arcsecond residuals if the achieved bandwidths were 0.5 Hz rather than 1 Hz.

3.3.12 ACCESS AND MAINTENANCE

During the design phase, attention has been paid to the locations of the drives and the hydrostatic bearings to ensure that sufficient access is provided for exchange of complete units. Such operations are to be performed using dedicated on-board cranes and handling tools located near the units.

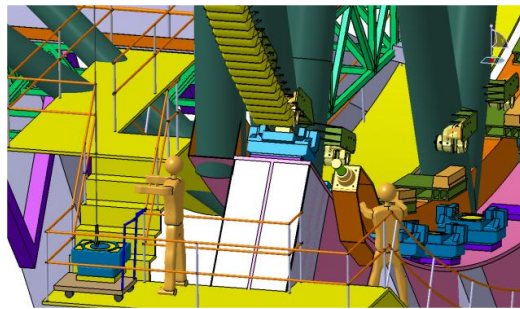

Figure 3.57. Access walkways for the altitude drives and pads.

The telescope provides easy access under the primary mirror units by a set of walkways built into the cell. The access to these walkways is from the Nasmyth level. The walkways work both at zenith and horizon pointing. The access to the tower is also possible both at zenith and horizon pointing.

A walkway on the periphery of the mirror cell provides access to the laser units.

A lift is built into each Nasmyth focus.

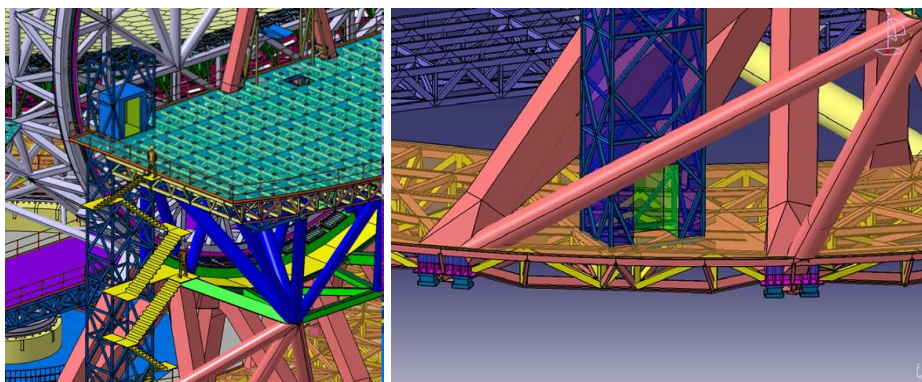

Figure 3.58. Lift for human and tool access to the Nasmyth platforms.

Accessing the primary mirror segments for exchange is an operation that will occur twice daily. A crane is mounted on a circular track mounted on the central tower. The main beam includes a telescopic extension and is supported by two horizontal and one vertical ties.

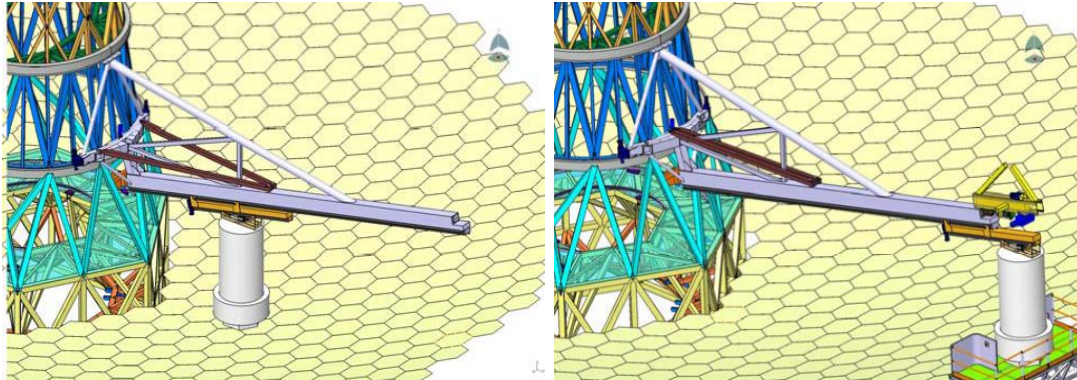

Figure 3.59. The jib crane mounted on the central tower.

The horizontal ties fold over the main beam during observations and the crane is parked below the radial spider to avoid obscuration.

The segment handling tool is responsible for the fine adjustments necessary to access the segment. At the periphery of the primary mirror a platform can be located under the jib crane and the segment can be placed there to be transferred outside the main structure volume for lowering down to the azimuth floor.

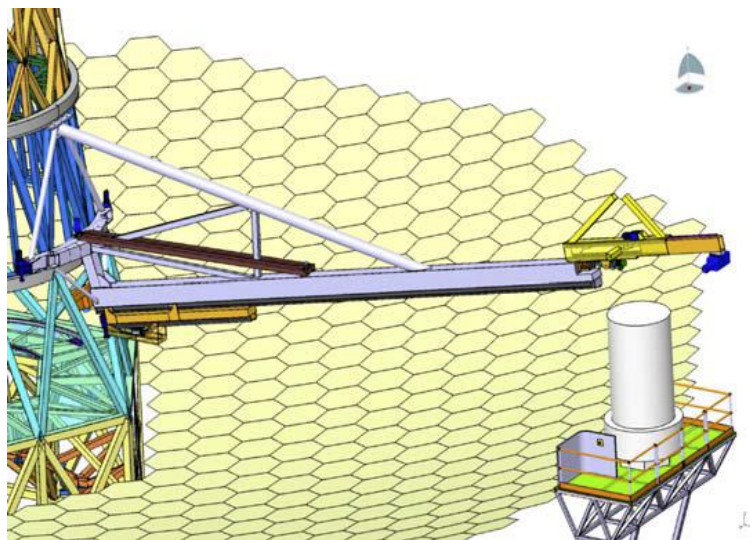

Figure 3.60. The retractable platform and segment lowering operation.

The secondary mirror unit is extracted from the crown with the telescope pointing to horizon. A particular challenge in this case is the management of the unbalance of the telescope with the secondary unit missing. Assuming the telescope is only constrained at the cradles, the crown will lift by 5 mm when the load is transferred from the telescope to the dome auxiliary crane. This is not extreme, although it does mean that the transfer will be complicated. Provision is made to restrain the telescope tube using pre-tensioned cables. Since this operation is likely to be performed a total of ten times in an extended 50-year lifetime of the telescope it is not regarded as overly constraining.

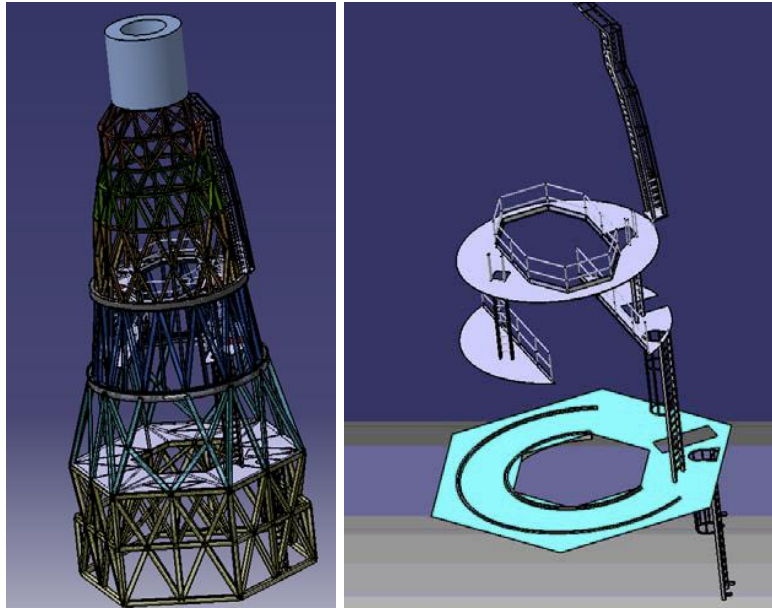

Figure 3.61. Human access to the central tower.

The tertiary mirror is lowered from the centre of the cell down to the azimuth level using an on-board 15-tonne crane mounted within the central tower. This operation is relatively simple. A transport carriage takes the mirror unit from the azimuth level to the edge of the main structure from where the lifting platform can lower it to the floor of the enclosure.

The same on-board crane transfers the M5 unit out of the telescope. The tertiary mirror must first be removed such that an appropriate opening can become available at the centre of the telescope.

The quaternary mirror unit is inserted/extracted with the telescope pointing to horizon. The upper structure of the telescope makes provision for the dome crane to access the unit. The unit is then lowered onto the azimuth floor.

The lasers are inserted using the dome crane.

3.3.13 EARTHQUAKE ANALYSIS

The design of the main structure withstands the Damage Limitation Requirement (DLR) of 0.26g PGA without damage and the no-collapse requirement of 0.49g PGA without major damage. As the design of the seismic isolation system in the telescope foundation is not yet finalised, the isolation effect to the main structure was not yet known at the time of the FEED study contract. Therefore, a simple and conservative assumption has been used for the main structure analysis verification, i.e. for the NCR, a PGA of 0.34g was assumed at the azimuth structure support interfaces (tracks). This corresponds roughly to a load reduction of 30% due to seismic isolation, whereas much larger reductions are expected, as confirmed in several studies. Detailed design and prototype testing of the baseline seismic isolation system is continuing.

The verification was carried out with a detailed nonlinear transient analysis of the main structure to predict the maximum azimuth and altitude support forces occurring during a NCR. As the preloaded hydrostatic bearings may open and bounce back under strong seismic loading, the nonlinear analysis approach was considered to be more accurate than the linear response spectrum analysis technique. The time histories generated for the three orthogonal directions have been applied simultaneously and a constant damping ratio of 2% in the critical frequency range was assumed. The simulations have been performed assuming brakes engaged.

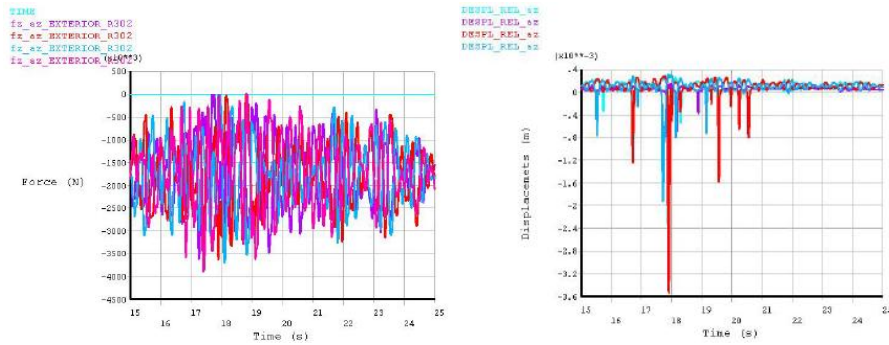

Figure 3.62. Vertical forces [N] and relative displacements [m] in the outer azimuth bearings under maximum likely earthquake without brakes (Pads AB and AC).

The maximum bearing forces and lift-off values under NCR earthquake loading are summarised below.

Bearing		Maximum force [tonnes]	Maximum lift-off [mm]	Comment
Azimuth	Vertical	390	0.4	Outer ring
Azimuth	Radial	63	10	Spring-loading until 10 mm distant end stop and friction interfaces added
Altitude	Radial	357	0.8	
Altitude	Lateral	88	–	

Table 3.5. Maximum bearing forces and lift-off values under NCR earthquake loading.

Almost all maximum accelerations calculated at the hosted units under NCR meet the specified requirements. The maximum acceleration occurs at the ADC with 2.8g, which is slightly above the specification. Most of the accelerations could be reduced considerably thanks to the sliding friction device implemented in the radial azimuth bearings.

The maximum stresses in the steel structure have been obtained from the NCR load cases (nonlinear transient analyses) combined with gravity load. Stresses caused by other loads like wind and thermal are very small. All the maximum stresses are below the allowable ones and are of local nature. The maximum stress distributions in the M1 cell (230 MPa) and in the azimuth floor (216 MPa), respectively are displayed in Figure 3.63.

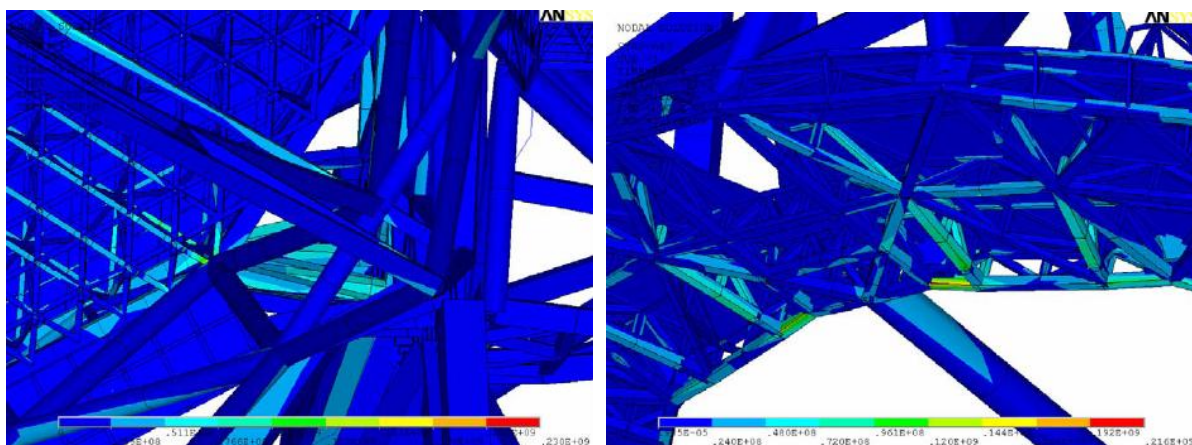

Figure 3.63. Maximum stress distribution in the M1 cell (left) and azimuth floor (right) in Pa.

As discussed in the dome section, a seismic isolation system is envisaged for the main structure pier that would radically reduce the accelerations on all components of the structure. As for the 42-metre design, the analysis here demonstrates that with sensible engineering precautions the telescope can withstand the NCR earthquake without significant damage.

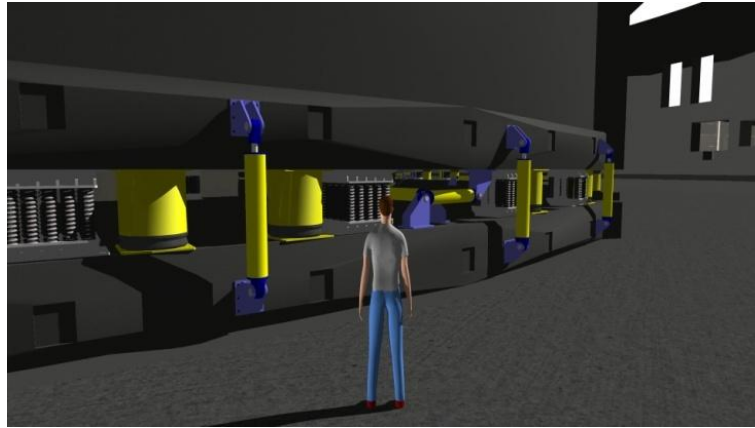
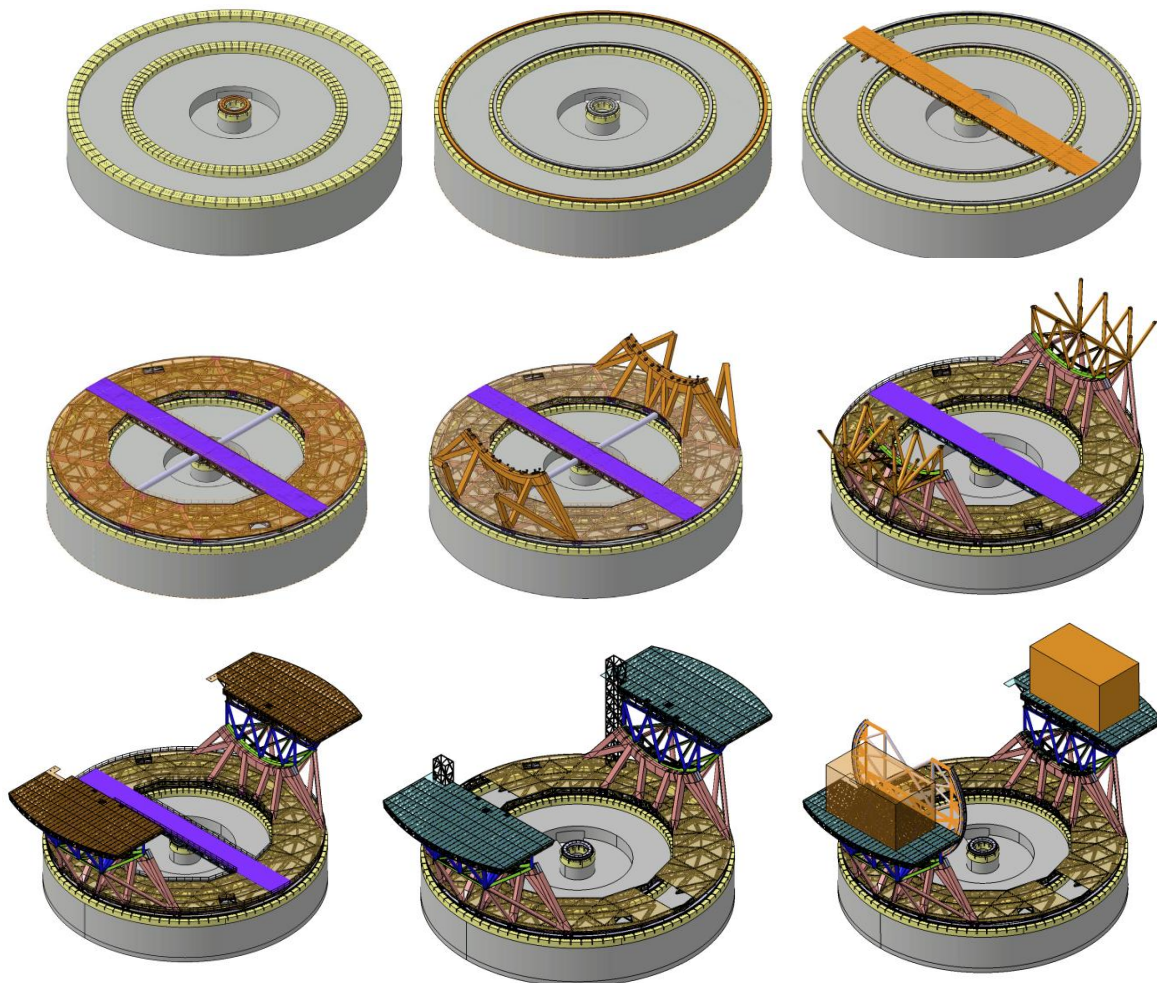

Figure 3.64. Seismic isolation for the main structure combining both vertical and horizontal damping (IDOM solution).

3.3.14 ERECTION SEQUENCE

As is the case for the dome, in addition to the FEED contractors, the erection sequence of the main structure has been evaluated in dedicated contracts with alternate specialist contractors. As these contracts were running in parallel with the FEED contracts and the erection sequences established by these suppliers are based on an earlier variant of the main structure design. The differences are not considered critical and the feasibility and schedule are confirmed by the suppliers.

The erection, predictably, starts with the installation of the interface to the telescope pier (the tracks).



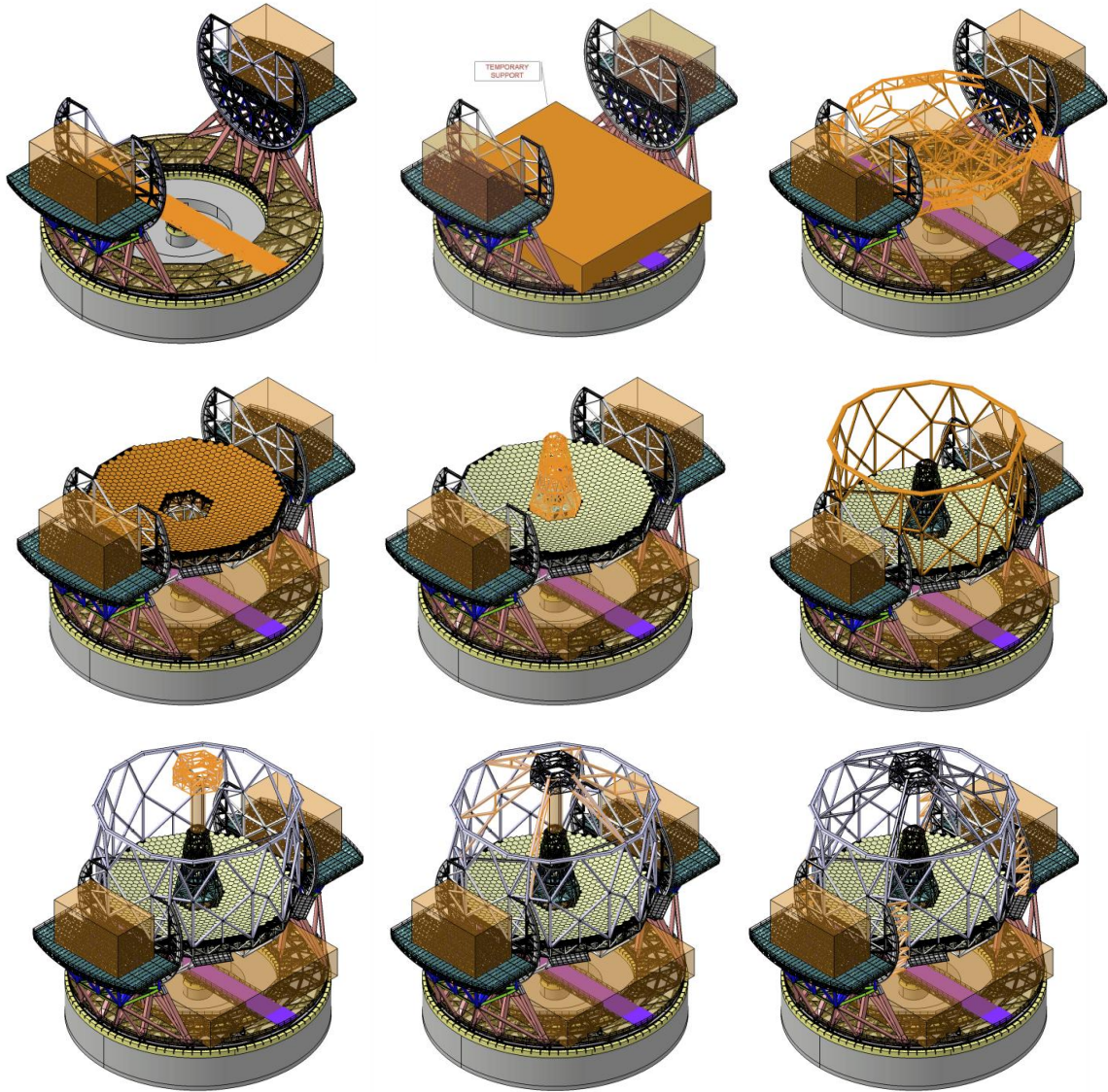

And finally the finished item:

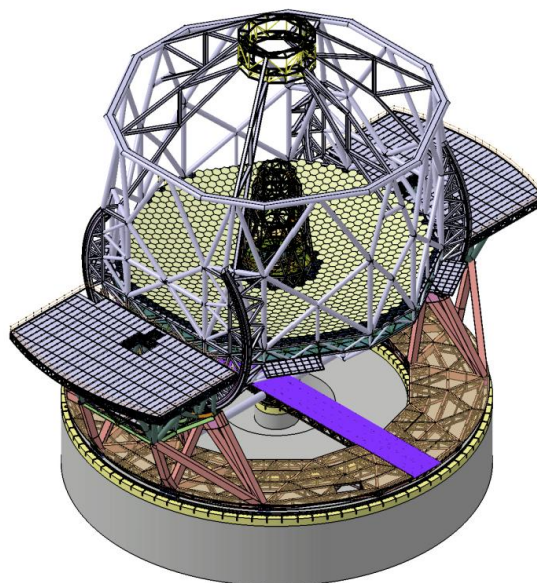

Figure 3.65. The complete main structure erected including all 798 dummy segments.

3.3.15 RELIABILITY AND OPERABILITY

For all subsystems contracted to industry, the project has required the generation of Reliability, Availability, Maintainability and Safety (RAMS) analyses. Updates to the 39-metre design of these analyses do not show critical changes with respect to the 42-metre version.

3.3.16 CHALLENGES

3.3.16.1 MANUFACTURING

The main manufacturing challenges for the main structure are schedule related. For an efficient erection, the necessary pieces have to be present on the site at the appropriate time. The risk that a fairly substantial crew is idle on site waiting for pieces to arrive from Europe is difficult to mitigate without pre-fabrication.

The possibility that adverse weather blocks crane operations for a period of time (e.g., high winds) has been analysed by the contractors based on the weather statistics of Armazones. The tight accuracy requirement of the mechanical elements that define the telescope main axes is a risk that can be mitigated with pre-assembly and site machining.

3.3.16.2 PERFORMANCE

The final performance of the main structure is likely to be limited by its dynamic behaviour. The size of the telescope is such that the differences between the “as built” and “as designed” machine are likely to be significant. It is critical that during the erection great care is taken not to introduce significant additional stresses into the telescope that would produce variable performance over time or introduce alignment issues as the telescope ages.

Over the lifetime of the telescope, it is likely that the performance of the main structure will be judged on the ease with which it is maintainable and permits access to the hosted units. This performance requirement is challenging to evaluate and to generate an objective cost benefit analysis for.

3.4 PRIMARY MIRROR UNITS

3.4.1 CONCEPT

The E-ELT primary mirror (E-ELT M1 or M1) is a 39-metre diameter elliptic concave mirror, with a 69-metre radius of curvature. The M1 mirror is made of discrete optical elements: the primary mirror segments. The segments are quasi-hexagonal, about 1.45 metres in size (corner to corner) and 50 mm thick (thickness at centre). The gap between the segments is 4 mm. The segments are made of low expansion glass or glass-ceramics.

The hexagonal segmentation pattern has a six-fold symmetry. The segments are grouped in six sectors of 133 segments, thus the primary mirror is made of 798 segments. All 133 segments of a sector are different in shape and in optical prescription; there are 133 segment families, or segment types.

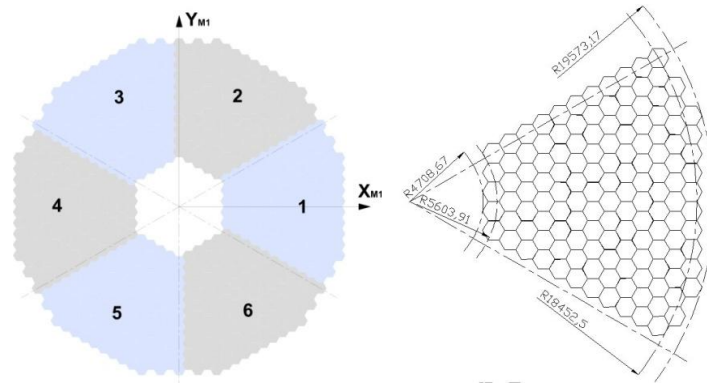

Figure 3.66. Primary mirror segmentation pattern.

A total of seven sectors, 931 segments, are procured. Having seven segments per family allows for a realistic operation scheme in relation to coating. A segment taken out of the telescope for recoating can immediately be replaced by another of the same family, which has been prepared beforehand. The segment reflective coating lifetime is about 18 months, so one or two segments will need to be replaced/coated every day.

The hexagonal geometry permits the use of a common support structure for all segments. Only slight counterweight adjustments are needed to compensate for the 1% segment in-plane shape variation between the different families.

The segment and its support form a segment assembly. The segment support is integrated once for all to the segment. The segment assembly is installed on a fixed frame assembly permanently attached to the telescope main structure.

The segment assembly is moved in piston and tip-tilt using three position actuators (PACT). Inductive edge sensors are used to provide direct feedback to the position actuators and for global reconstruction of the mirror shape.

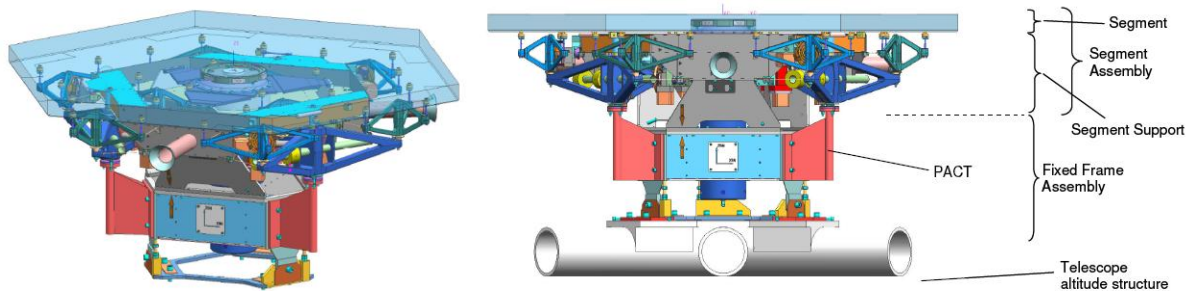

Figure 3.67. The segment assembly and its fixed frame assembly form a segment subunit.

3.4.1.1 SEGMENT

The segment is made of the polished glass-ceramic substrate and its interface to the segment support and to the edge sensors.

The segment attachment to the axial support system uses 27 axial pads. Six lateral pads are bonded in the segment centre pocket to interface with the lateral support. Three azimuthal pads are also added to constrain the rotation of the segment, one of each being used as a reference to define the segment local coordinate system. The axial, lateral, and azimuthal pads are made of Invar.

In addition, a set of 12 edge sensor interfaces are bonded to the back side of the segment.

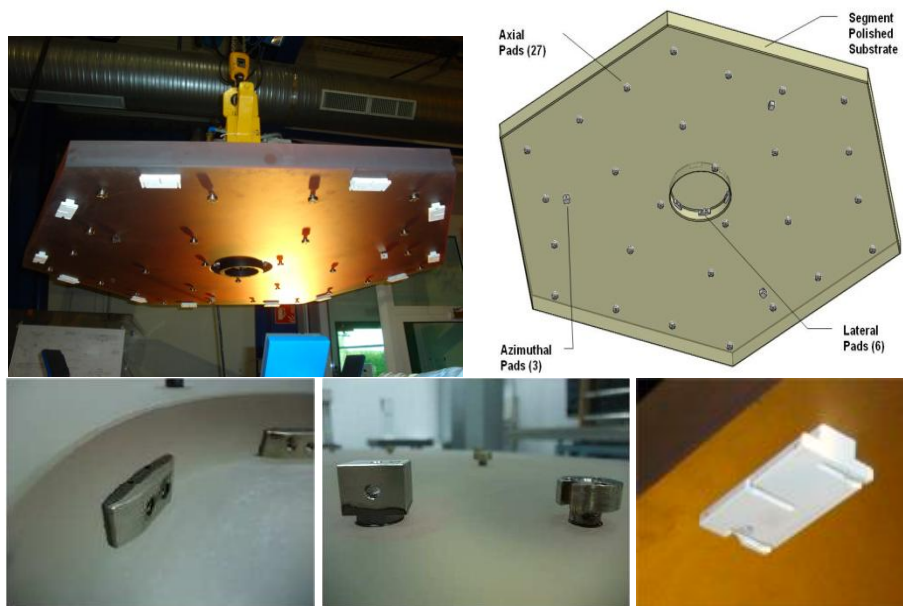

Figure 3.68. Left: Lateral pads. Centre: Axial and azimuthal pads. Right: Interface with edge sensor.

3.4.1.2 SEGMENT SUPPORT

The segments are axially supported on 27-point identical whiffletrees. A lateral restraint is located in the centre of the segment using a membrane to allow limited motion in the direction orthogonal to the back surface. A clocking restraint is used to further limit the rotational freedom of the segment. The whiffletree loads can be adjusted using one or more of nine warping harnesses at selected joints.

The segment support is connected to a moving frame which decouples the segment assembly support from active motion.

3.4.1.2.1 Segment axial support

Three nine-point whiffletrees are joined to provide 27 axial supports for the segment. The whiffletrees have a primary tripod supporting three secondary tripods. The segment load is taken by rods that have high axial and low lateral stiffness.

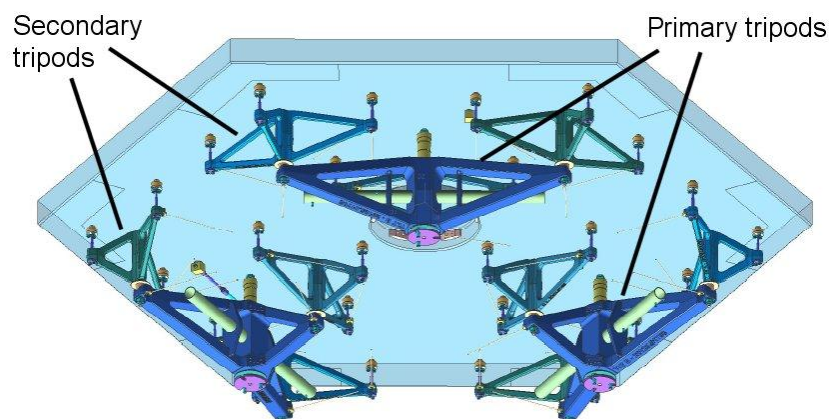

Figure 3.69. The whiffletree structure.

Significant attention has been paid to the ease of manufacture for these components as they will be produced in over one thousand units. The primary and secondary tripods are cast aluminium structures.

The connections between the tripods, and between the main tripods and the position actuators, are made using articulated struts that only transmit axial loads. Lateral struts connect the tripods to the moving frame to constrain their in-plane and rotation motions and obtain high stiffness of the assembly.

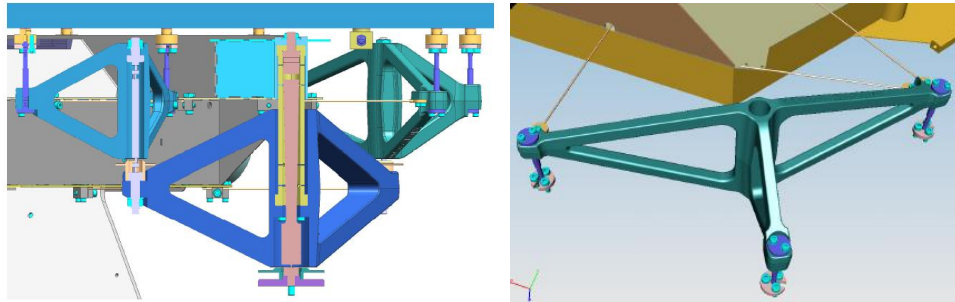

Figure 3.70. Left: Whiffletree struts. Right: Axial and lateral.

For segment shape compensation counterweights are mounted on the primary tripods with a lever arm. The lever arms length is adjusted for each segment family. Those compensate for astigmatism variation. Focus variation is compensated at the level of the lateral support.

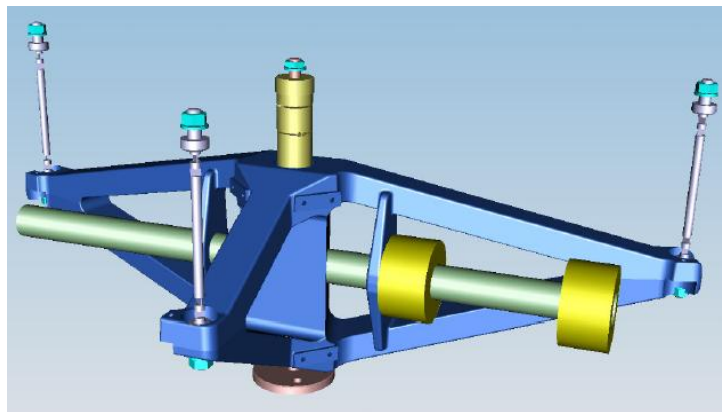

Figure 3.71. Segment shape counterweights.

3.4.1.2.2 Lateral support and clocking restraint

The lateral support is provided by a central membrane installed in the segment central hole, as close as possible to the neutral fibre of the segment. The membrane permits the few tenths of millimetres of travel in the piston direction that is required to compensate integration errors of the mirror on the support structure and thermal fluctuations when in operation.

The central membrane is made of nickel-plated high-strength steel and is about 0.25 mm thick. A counterweight is attached to the lateral support to compensate for the variation in segment shape (focus).

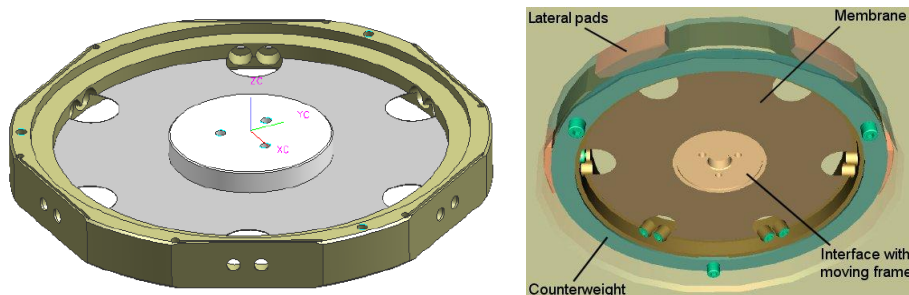

Figure 3.72. Segment lateral support.

A clocking restraint is attached to one of the three azimuthal pads. The clocking restraint is a strut connected to the moving frame. It provides additional stiffness to the assembly in the direction of rotation about the segment optical axis (clocking). The connection of the azimuthal pad can be chosen so as to minimise the segment distortion under gravity when the telescope is pointing towards the horizon, depending in which sector the segment is installed.

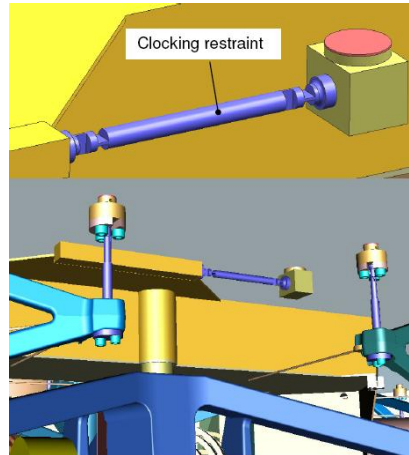

Figure 3.73. The connection of the clocking restraint to the moving frame.

3.4.1.2.3 Moving frame

The axial support, lateral support, and clocking restraint are all attached to the moving frame.

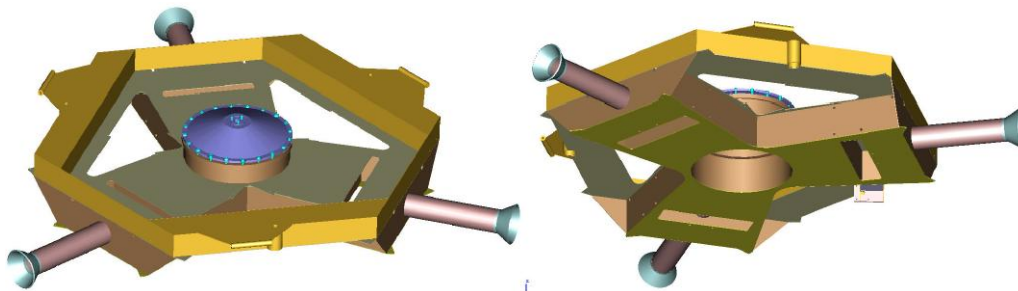

Figure 3.74. The moving frame.

The moving frame is a sheet-metal box structure assembled using plug welding. The material used is stainless steel. The sheet-metal assembly allows the weight and cost of the structure to be minimised.

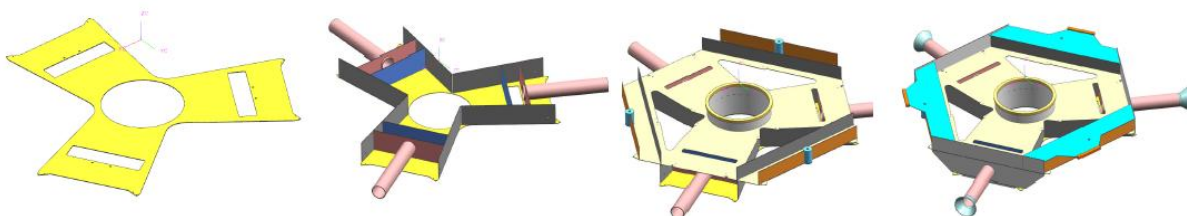

Figure 3.75. Left: The moving frame box structure. Right: Sheet-metal plug welding.

The moving frame has three flexures that provide an accurate attachment interface with the fixed frame. These flexures constrain the lateral and clocking motion and permit the piston/tip-tilt motion of the segment assembly.

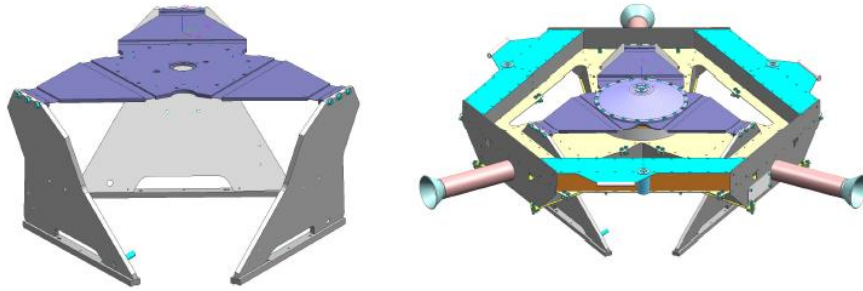

Figure 3.76. The moving frame flexures and moving frame assembly.

The moving frame includes three tubes and conical interfaces which are used to handle the whole segment assembly.

3.4.1.2.4 Warping harnesses

The segment assembly includes nine shape actuators and the warping harness, which allow three aberrations to be corrected: curvature, astigmatism and trefoil. Those aberrations are induced by thermal and gravity distortions of the segment assembly and of the telescope main structure, and by errors from manufacturing and testing.

The actuators modify the forces applied by the axial support to the segment by applying a torque at the location of the tripod pivots.

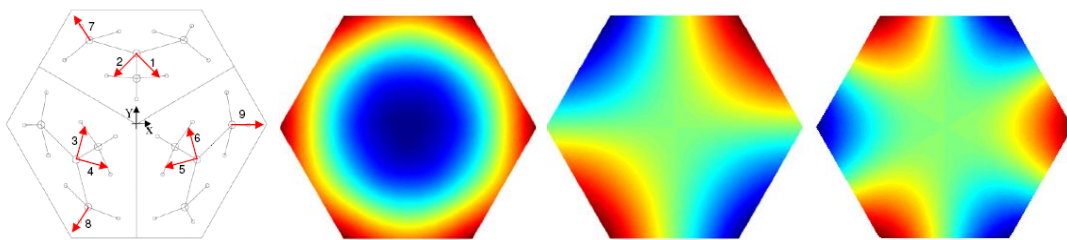

Figure 3.77. The warping harness torque distribution and deformation mode shapes: focus, astigmatism, trefoil.

The moments are applied by rotating a helicoidal spring using a simple stepper motor and gear box, connected between the tripods or between the fixed frame and the main tripods. A potentiometer measures the spring rotation and hence the torque amplitude.

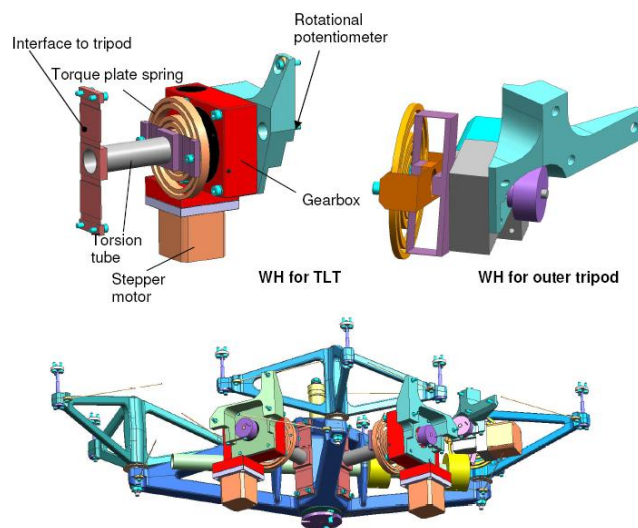

Figure 3.78. Upper image: Warping harness. Lower image: Rotating helicoidal spring and potentiometer.

3.4.1.3 FIXED FRAME

The fixed frame connects the segment assembly to the telescope mirror cell and houses the position actuators. It connects to the moving frame through the primary tripod flexures and moving frame flexures. It includes a segment extractor which allows the segment assembly to be lifted above the primary mirror to provide sufficient clearance to grab it with the segment handling tool.

The fixed frame is attached to the telescope main structure is through the integration stage, which is used during telescope integration to adjust the positions of the subcells along six degrees of freedom very accurately, and so forms a reference for where to locate the segment assemblies.

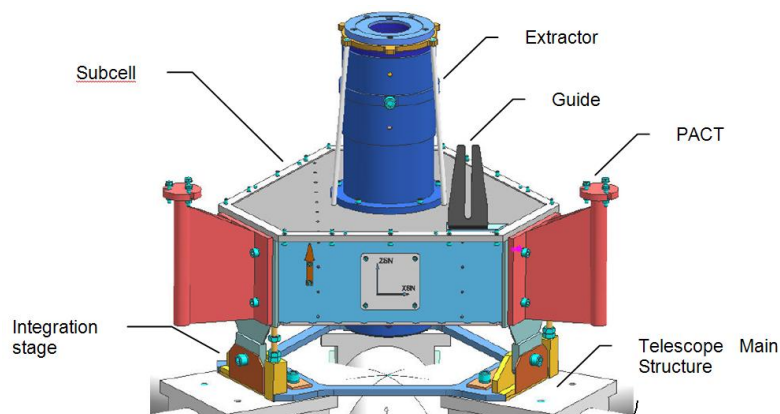

Figure 3.79. The fixed frame.

3.4.1.4 SEGMENT SUPPORT PERFORMANCE SUMMARY

The total mass of each segment subunit is approximately 325 kg including the position actuators, edge sensors and their front-end electronics. The segment assembly accounts for 245 kg.

The first eigenfrequencies of the segment subunit are in the 30–60 Hz range.

The segment surface distortion due to gravity is 12 nm rms lateral, 14 nm rms axial.

The segment surface distortion due to thermal changes is 0.25 nm rms per °C, which is negligible.

The coupling between piston/tip-tilt adjustment and segment shape is negligible, in order of 2 nm rms.

The accuracy of correction of the segment shape variation using the counterweights is in the order of 10 nm rms.

The warping harness segment shape correction has a 2% relative accuracy.

3.4.2 SEGMENT ASSEMBLY MANUFACTURING

3.4.2.1 POLISHING REQUIREMENTS

The polishing specification of the segment assembly pointing at the zenith and including the integration on the supporting structure requires that a segment does not exceed 100 nm rms maximum wavefront error and 50 nm rms wavefront averaging over all the segments. After correction of 85% of focus (Z3), astigmatism (Z4 & Z5) and 85% of trefoil (Z8 & Z9) by the warping harness, the maximum error will reduce to being less than 30 nm rms wavefront and 15 nm rms wavefront on average.

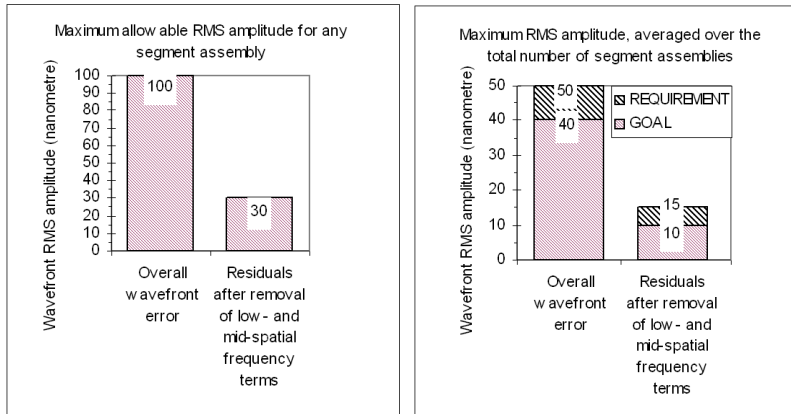

Figure 3.80. Presentation of the segment errors.

The useful area of the segment is defined as the polished area up to 10 mm from the edge with a goal of 5 mm. The specifications allow a maximum wavefront error of 400 nm peak-to-valley in this area and an average of 200 nm. The impact of this specification on the phasing and image quality has been addressed in the design study. However, the point may be moot as the prototyping activities discussed below have largely mitigated the polishing to the edge risks. The micro-roughness is expected to be below 20 Å.

3.4.2.2 PROCESS OVERVIEW

The baseline manufacturing plan of a segment assembly defined during phase B is shown below.

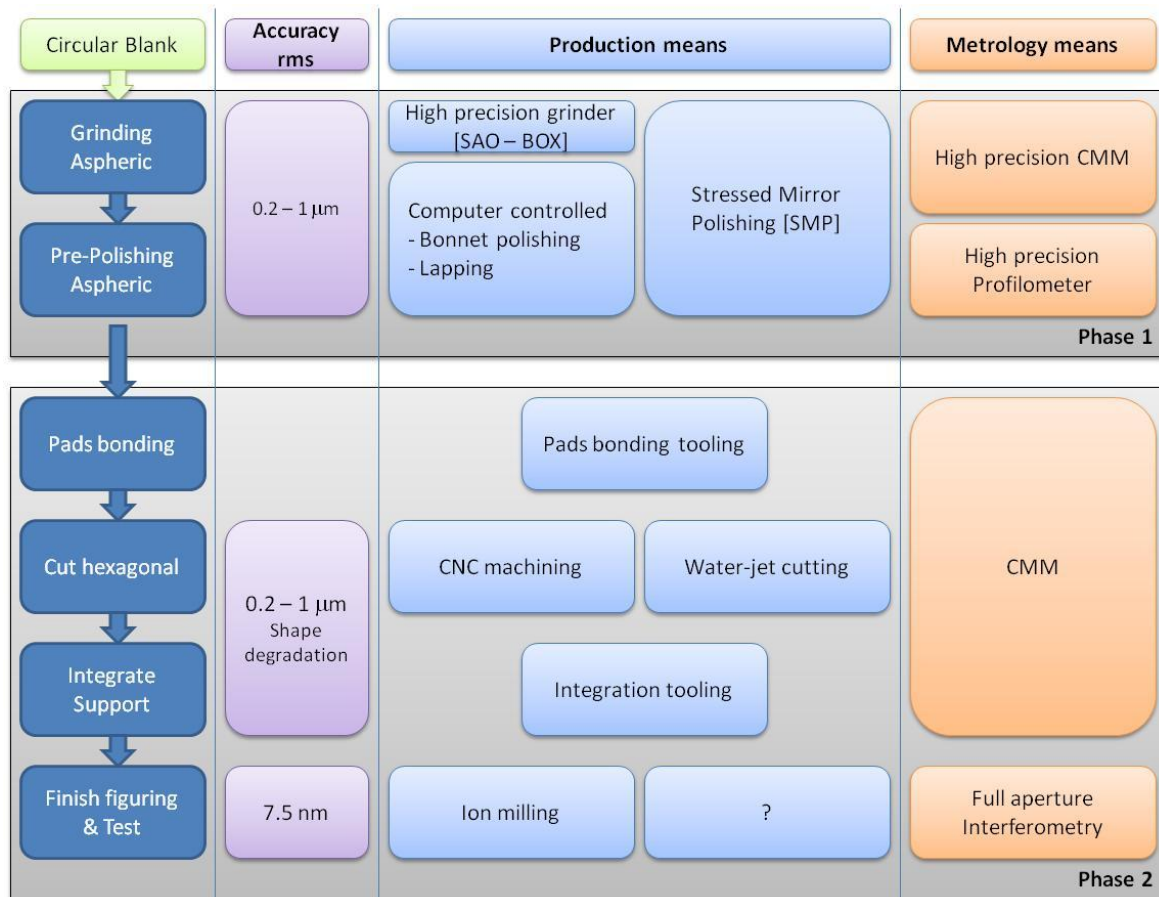

Figure 3.81. M1 segment assemblies – figuring process.

The process is summarised as follows:

- Procure a circular segment blank;
- Figuring phase 1: Pre-polish the circular blank close to its final optical quality;
- Figuring phase 2: Bond the pads, cut the segment to its final dimensions, integrate the segment support and finish figuring the segment assembly by ion-milling.

Ion-milling has the following advantages:

- Polishing circular segments leaves a significant margin on the outer edge of the blanks;
- A lapping process, either full size by stress mirror figuring or by computer-controlled polishing, generates optical shape errors on the edges, such as turn-down or turn-up edges, or combinations of both forming S-shaped errors;
- The segment optical surface needs to be accurate to the very near edges to avoid errors when phasing the primary mirror and to avoid a large energy loss and undesired light patterns;
- For metre-size optics, such errors are typically a few centimetres wide. They are very difficult to correct, both in terms of metrology and in terms of process (high slopes, very local corrections) and thus very time-consuming;
- Working a circular segment allows these errors to be located beyond the hexagonal optical surface of the final segment. The average margin on the edge is 45 mm. This margin is sufficient for both computer-controlled polishing and stressed mirror polishing;
- Cutting the segments to their final hexagonal shape produces a moderate low-order segment distortion (springing), but negligible edge local distortion (hardly detected by local interferometry).

This process has been verified on four segments made by SAGEM, made of Zerodur™ from Schott (G), ULE™ from Corning (US), Sital™ from LZOS(RU). In addition to correcting the errors left by segment pre-polishing and hex cutting, ion-milling can correct the distortions induced by:

- Gravity (zenith pointing), including the distortion induced by the edge sensors;
- Integration of the segment support (at room or operational average temperature);
- Ion-milling does not produce any edge residuals since it is not a mechanical removal process.

3.4.2.3 GLASS PROCUREMENT

The baseline material for the primary mirror is Schott Zerodur. The total amount of Zerodur necessary for the E-ELT primary mirror is significantly less than the installed annual production capacity of Schott. This makes the production of primary substrate a non-critical component of the project.

The production would take place at Schott's Mainz factory and the annealing ovens are already in place. The first segments would be delivered to the project within a few months of the order. Sufficient Zerodur exists on stock to allow early production runs to take place.

The production is scheduled for four and a half years with 50 segments being delivered in the first year and 250 the second. In the following three years approximately a segment will be delivered every day of the year to make the total of 931 discs.



Figure 3.82. Left: Annealing facility at Schott in Mainz. Right: Sample boule.

The specification for the glass has been agreed with the polishers. The optical surface will be finished to D35 while the other surfaces will be acid etched to remove subsurface damage caused by the machining process that extracts the segment from the boule.

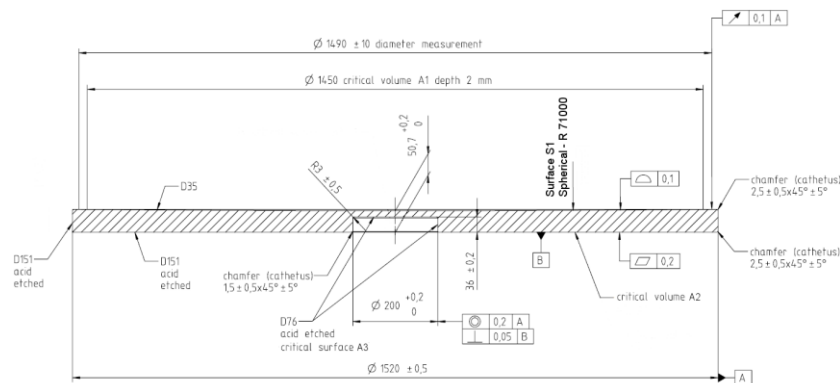

Figure 3.83. Segment blank dimensions.

3.4.2.4 PHASE 1 — ASPHERIC GRINDING AND PRE-POLISHING

3.4.2.4.1 High precision grinding — SAO

SAO is a proprietary process developed by Sagem, based on computer-controlled abrasive fluid jet grinding. It has been successfully used for the fabrication of the segments for the GTC.

The removal and convergence rates of the SAO process are good enough to aspherise one segment per day on average. The subsurface damage left by the process is low, typically less than $10 \mu\text{m}$, and there are no “cusp” residuals left on the surface. A fast fine grinding by computer-controlled lapping is necessary after SAO processing, typically a few hours. The final shape error has been shown to be of order $0.2\text{--}1.0 \mu\text{m rms}$.

3.4.2.4.2 High precision grinding — Box grinder

The Box grinder developed at Cranfield University is a high precision three-axis grinding machine.

A vertically arranged Z linear axis subsystem carries a fixed inclination grinding spindle. The Z-axis is mounted within a horizontal X linear axis carriage. A large rotary C-axis table is employed to hold the mirror. The grinding spindle is tilted at a fixed 20-degree angle to enable machining of free-form optics of slope up to 18 degrees. This maximum slope is suitable for the E-ELT segment surfaces.

The Box grinder has a built-in measurement profilometer employing a non-stressed metrology frame and a form accuracy of $1 \mu\text{m}$ peak-to-valley is targeted with minimal levels of induced subsurface damage.

Grinding is performed by successive rough to fine cuts. The internal metrology of the machine allows the segment shape to be measured along radii. At the current stage of machine development, a measurement of the segment surface using a 3D-coordinate measuring machine is required to provide the feedback and achieve the final accuracy. The recent results obtained on E-ELT prototype segments show that a final shape accuracy of a few micrometres peak-to-valley can be achieved. The total processing time to machine a segment is 20 hours, although this can be brought down to closer to 10 hours by following up on improvements arising from the early work on E-ELT segments.

The subsurface damage has been measured to be 5–10 μm Ultra Low Expansion (ULE) glass. The machining leaves cusps of 0.1 μm over spatial scales of a few millimetres. The combination of the subsurface damage and the cusps implies that a post-generating pre-grinding is necessary.



Figure 3.84. Cranfield Box machine.

3.4.2.4.3 Bonnet pre-polishing

Pre-polishing is performed using raster scans with fast polishing bonnets, combined with a few runs of computer-controlled pitch lapping to get the required surface smoothness.

Different processes are available: CARP (Sagem), precession bonnet polishing (Zeeko), and similar ones from other vendors.

Bonnet polishing has a good convergence rate and quite a high removal rate. The process is fully automated and is not operator dependent.

The process has been demonstrated by Sagem and OptIC in the fabrication of prototype segments for the E-ELT. In closed loop the wavefront error has been shown to be 100–200 nm rms while the surface roughness is at the nanometre level, as is the subsurface damage.



Figure 3.85. Large-scale Zeeko polishing machine at Optic Glyndwr.

3.4.2.4.4 Stressed mirror polishing

The principle of Stressed Mirror Polishing (SMP) is derived from the methods used to produce Schmidt plates: the disc is bent to the negative required final shape, machined, ground and polished spherical.

Since the bent disc is polished spherical, the grinding and polishing can be performed using full- or large-size laps, converging to the final shape and roughness very rapidly. Using full-size laps, the quality of the optical surface is very smooth, with no ripples and very low amount of high spatial frequency errors. The SMP process was successfully used to produce the Keck segments.

At the time of writing, SMP is being tested by several vendors on full-scale E-ELT prototype segments: Tinsley (US), LAM (Laboratoire d'Astrophysique de Marseille, F) in collaboration with Thales-SESO (F), and Sagem (F).

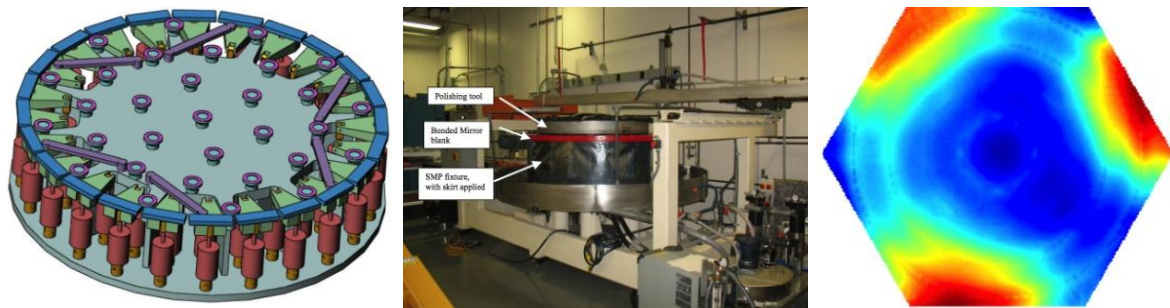

Figure 3.86. Left & centre: The stress mirror fixture from Tinsley. Right: Segment residuals from the Tinsley process (3 μm peak) (hexagonal extract from oversized polished surface).

This is a validated and highly efficient process with existing tools. The prototype studies aim to confirm the accuracy the process can achieve, and the way it can be replicated for mass production.

Prototyping of segments using these tools has also been performed by TMT and surface errors of 1.2 μm (after removal of low-order terms) have been achieved. Better results have been reported to the project but not as yet published.

3.4.2.4.5 Phase 1 baseline

The project baseline is that phase 1, pre-polishing, and phase 2, integration and finishing, should be taken over by a single supplier.

However the project considers that all these suppliers can be offered the option to bid for the first stage work. The schedule established assumes that one or more suppliers will be working on aspherising the segments and that this may include the supplier of the finishing.

3.4.2.5 PHASE 2 — FINISHING THE SEGMENTS

3.4.2.5.1 Cutting

The segments are machined into their hexagonal shape using conventional fixed abrasive grinding on a Computerised Numerical Control (CNC) machine. First a grinding disc cuts the segment edge down to 1.5 mm from the back surface. The outer part is then broken off by hand. In a second step the segment edges are machined using a surfacing tool and finally the 1 mm chamfer is machined on the front surface, and the 3 mm \times 3 mm chamfer on the back surface. The location of the segment (the corners) with respect to the global coordinate system is better than ± 0.1 mm for the location and the surface finish is D64 with a flatness of about 20 μm .

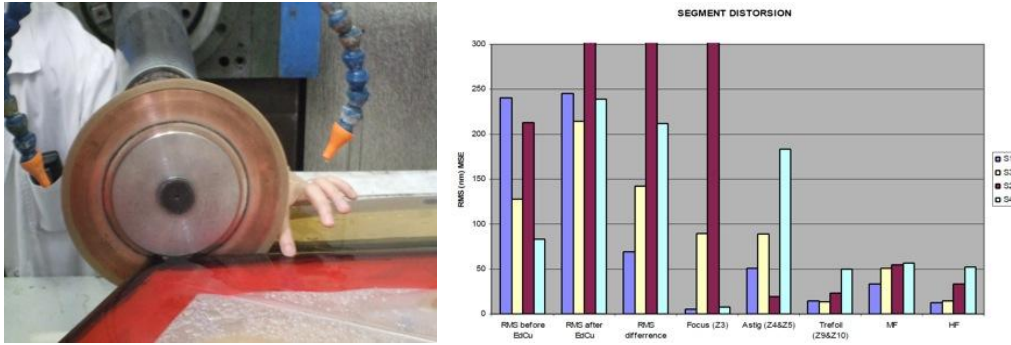

Figure 3.87. Segment cutting and measured segment distortion after cutting (s1/blue Zerodur, s3b/yellowAstrosital, s2/red & s4/cyan ULE).

With the exception of one disc no significant distortion appeared after cutting the prototype segments. Interferometric maps of the edges do not show any local effects arising from the cutting.

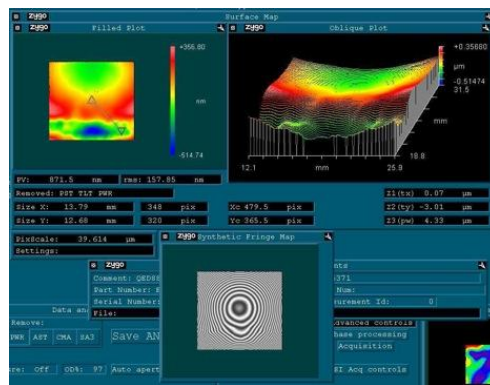

Figure 3.88. Interferometric measurements of the edge of one of the segments. The effect on the lower side of the image is a polishing residual and not related to the cutting (cut edge is on top).

3.4.2.5.2 Finishing

For finishing the segments the ion-beam process is considered as the baseline. This has been validated at two suppliers, Sagem (France) funded by ESO and ITT (US) funded by the TMT project.

The segment support is integrated with the segment to form the segment assembly. The whole segment assembly is vacuum compatible, including the warping harness components. Hence there is no need to dismount any component before ion-milling the optical surface or later for reflective coating when in operation.

The finishing process has been fully demonstrated on four prototype segment assemblies: the process is mostly limited by the metrology, the registration of the segment with respect to the machine, and by the high spatial frequency errors left on the optical surface by the previous polishing steps. The ion-beam size limits the correction to typically 25–50 mm spatial periods. Ion-beam processing is highly deterministic and has convergence rates of 85%.

The ion-beam process has a baseline removal rate of typically 20–50 mm³ hour⁻¹. Higher rates are in principle achievable; the process will be further optimised during construction.

Two iterations as a minimum with the ion-beam finisher are planned. The first run is expected to last 10–15 hours while the subsequent runs are planned at approximately two hours.

Ion-beam figuring delivers the final segment with the print-through and distortions induced by the integration of the segment support removed.

3.4.2.6 METROLOGY

For the generation of the aspheric surface a commercial 3D-Coordinate Measuring Machine (CMM) will be used. At the pre-polishing and polishing stages a non-contact optical profilometer will be utilised. It comprises six or more optical sensors on a radial bar above the segment, which in turn rests upon a rotating table. The combination of sensor translation and segment rotation is used to scan the whole segment surface. A measurement time of 15 minutes is foreseen. The sensors can measure either polished or fine ground surfaces and therefore both the early and late stages of the aspherisation can be monitored using the same machine to an accuracy of below 2.5 μm peak-to-valley surface error.

The system will be calibrated using a reference sphere, already produced during the manufacturing of the prototype segments and cross-checked against a reference segment kept as a datum during production.

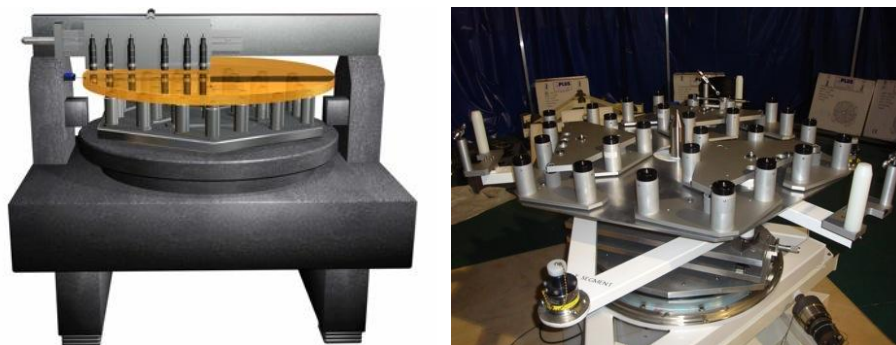

Figure 3.89. Left: 3D-Coordinate Measuring Machine. The baseline optical profilometer to be used during aspherisation. Right: The metrology whiffletree.

During the aspherisation the segment is still circular and a dedicated metrology whiffletree has been built to support the segment. The metrology whiffletree has 27 points and interfaces to the segment at the same locations as the final support. Counterweights compensate the difference in mass distribution between the metrology whiffletree and final support. The difference between the metrology whiffletree and the final support accounts for 50 nm surface error to be removed in the final ion-beam runs.

During production, for the final ion-beam finishing, Sagem proposes that the metrology is provided by a Fizeau matrix test. The test setup for this has been developed by the University of Arizona mirror lab.

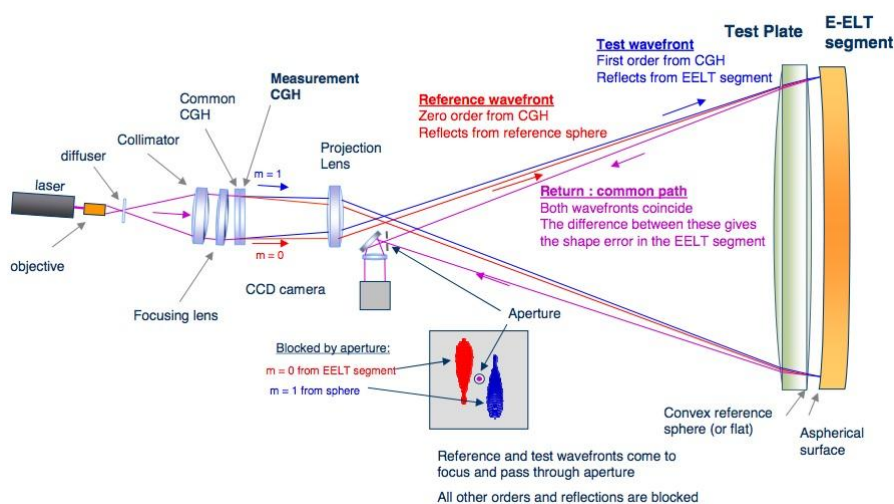

Figure 3.90. Sagem's (Arizona mirror lab) proposed test setup for final production.

The concept of the test setup is that a reference wavefront is generated from the convex surface of the test plate and interferes with the wavefront returning from the concave optical surface of the segment.

Phase shift is created in the interference cavity by moving the test plate using piezo-actuators. The interference pattern is imaged on a CCD (Charged Coupled Device) and used to reconstruct the wavefront error of the segment using phase unwrapping methods.

A common 60 mm diameter Computer-Generated Hologram (CGH), used in zeroth order, shapes the beam to correct both the reference and the test wavefront. A second measurement CGH, also 60 mm in diameter and used in first order, shapes the beam to correct only the test wavefront. The reference and test wavefronts interfere in a common path after reflection on the test plate and the segment, and the pattern is imaged on a CCD camera.

The two CGHs can be engraved as a single pattern on the same substrate.

The full-aperture Fizeau test ensures that curvature matching between the segments is managed. The dominant curvature error comes from the variation of the spacing between the convex surface of the test plate and the segment. In the design adopted, an uncertainty of 0.1 mm causes about 1 nm rms focus surface error. In addition, the effects of turbulence in the environment of the test are expected to be negligible as the interference cavity is only a few tens of millimetres in length.

The test plate has a spherical reference surface and can be easily calibrated *in situ*, using a master spherical concave mirror. The calibration process measures the master mirror at different orientations (clocking) and de-centred positions.

The error budget for the test setup accounts for a number of sources including the overall alignment, fabrication errors in the components of the test setup, calibration errors and residuals from spurious reflections and noise. The error budget provides for 29 nm rms overall wavefront and 10 nm residual wavefront after removal of the focus, astigmatism and trefoil as allowed by the specification.

The option to test the segments at the operating temperature has been considered but at this time, given the test setup dimensions, not considered viable. Allowances for Coefficient of Thermal Expansion (CTE) variations, pad bonding adhesives, segment support thermal distortions and coating stresses have been made in the budget for the warping harnesses correction capabilities.

3.4.3 SEGMENT PROTOTYPES

In preparation for the construction proposal Sagem, Optic Glyndwr, Laboratoire d'Astrophysique Marseille and L3-com (Tinsley) have all been contracted to evaluate technologies and in some cases deliver prototype segments at different finishing levels.

Sagem has relied in part on existing infrastructures and some new toolkits to demonstrate their ability to deliver segments meeting the specifications, while at the same time prototyping production.

The first two stages of the Sagem process are shown below. Rapid aspherisation followed by pre-polishing.

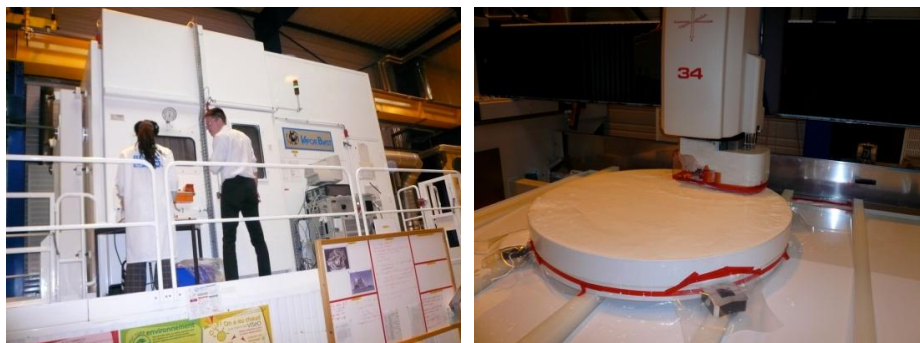

Figure 3.91. Apherising and pre-polishing at Sagem.

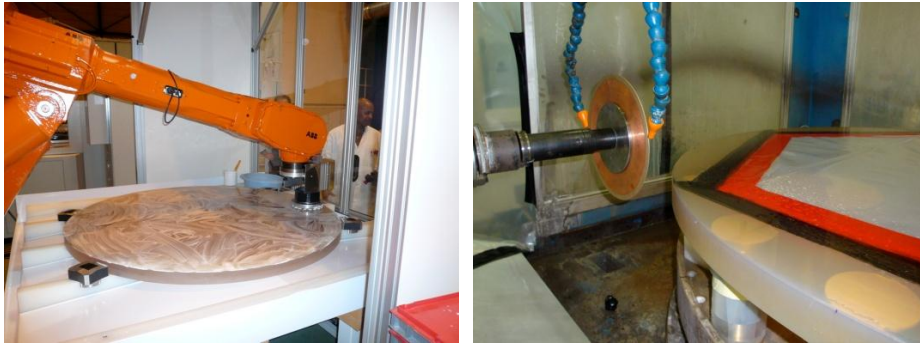

Figure 3.92. Medium-sized tool smoothing and cutting before ion-beam touching up.

It has been demonstrated during prototyping that cutting the segments does not produce edge residuals and that the segment warping after cut is fully compatible with ion-beam figuring. The first four segments at SAGEM have shown low spatial frequency distortions with amplitudes of order 100 nm rms wavefront or less.

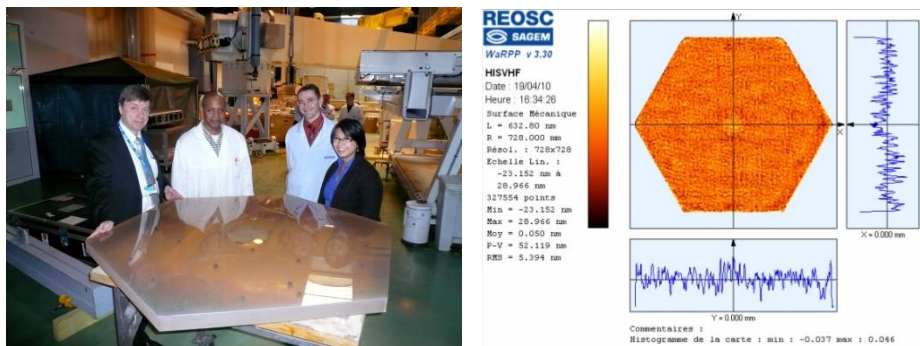

Figure 3.93. The first segment with Sagem personnel proudly surrounding it.

The whole production sequence has been followed, from blank procurement to ion-beam figuring. Three prototype segments have been integrated after hex cutting on segment supports provided by TNO and CESA. After ion-figuring the segment assemblies all have polishing residuals less than 14 nm rms wavefront error.

3.4.4 ACTUATORS

Three position actuators move the whiffletree, and consequently the segment, in piston and tip-tilt. The actuators are required to have sufficient stroke to reposition the segment to its nominal position compensating for the deflections of the underlying telescope structure. In addition, the actuators need to provide the resolution and accuracy necessary for phasing the primary mirror in the presence of disturbances. These are dominated by the wind across the front surface of the primary mirror and possible vibrations arising from machinery either directly under the segments or transmitted through the structure to the primary segments. For the wind we have assumed 1.6 ms^{-1} for the speed across the primary and a von Karman spectrum. The vibrations are simulated by injecting $5 \mu\text{g}/\sqrt{\text{Hz}}$ into the structure. This value has been determined from the measured accelerations at the Unit Telescopes (UTs) at Paranal and is considered a conservative number.

The analysis shows that correlated excitations can result in wavefront errors as high as 160 nm rms before the adaptive optics loop. These excitations are always at relatively low temporal frequencies with the integrated amplitude above 40 Hz (up to 500 Hz) being below 1 nm. The excitations are in low spatial frequencies with 5 nm wavefront error being accounted for by all modes beyond the first 64 modes of the entire primary mirror.

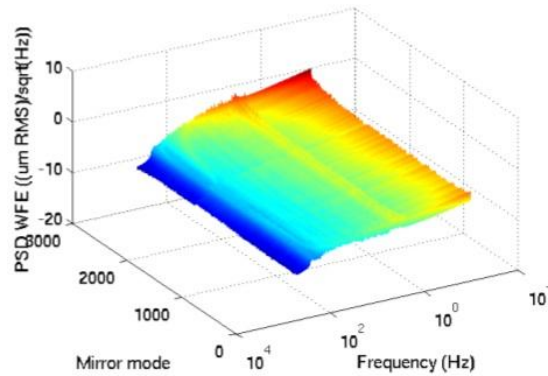

Figure 3.94. PSD of the primary mirror segments from vibration analysis.

The actuator is based on a high-bandwidth voice-coil actuator in series with a gravity off-loading electro-mechanical stage. An encoder is used to close the local loop. The layout of the actuator is shown in the two figures below that identify the key components of the design:

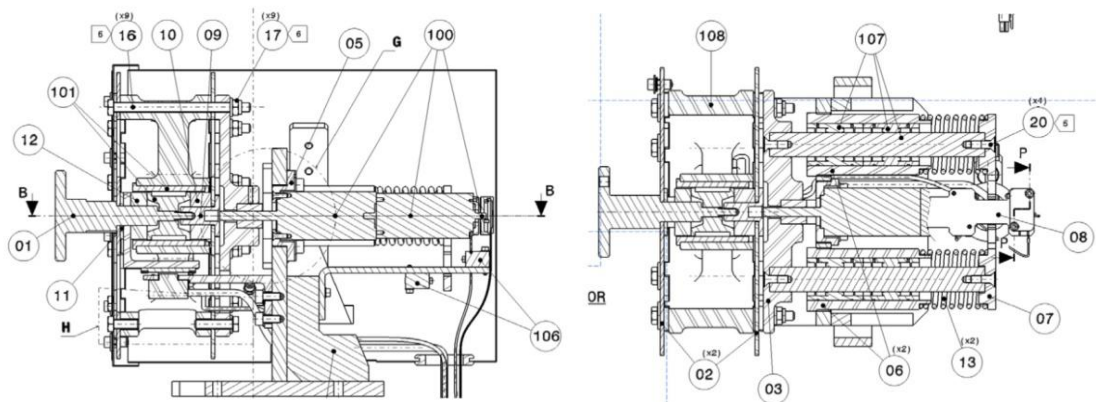

Figure 3.95. Layout of the actuator.

The actuator connection to the interface with the segment support (01) is driven through the voice-coil actuator (101) that is housed (108) between two leaf springs (02). The coarse stage is driven by a brushless motor through a gearbox and a rotary encoder (assembly 100). Linear guides (107) constrain the lateral movements and rotation (13). Two microswitches (106) limit the travel of the coarse stage to 17 mm.

The prototype systems have used a Maxon motor and gearbox with a 50:1 reduction factor which reduces the power demand of the actuator. A rotary encoder is included in the system with 500 steps per revolution. The rotary encoder is used to control the speed loop of the offloading stage. The gearbox requires a preloaded screw to avoid backlash, introducing some control challenges in a holding position. In production the actuator could use a harmonic drive thereby reducing this risk.

The combination of a lead screw (2 mm pitch) and a nut in the drive shaft of the actuator ensures that the system is not susceptible to significant movements should the power be removed from the actuator.

In the prototype system encoding is performed using a Heidenhain sensor with subnanometre resolution and an absolute accuracy over 10 mm travel of 250 nm and, over short travels of 100 nm of 6 nm. The Heidenhain encoder is connected to the output shaft directly and can be used to compensate for control errors as well as other perturbations.

Two flat springs are used to provide axial flexibility to the voice coil while restraining it laterally. Under the operating load of 880 N these aluminium springs deflect by approximately 3 mm and the maximum induced stress is 192 MPa.

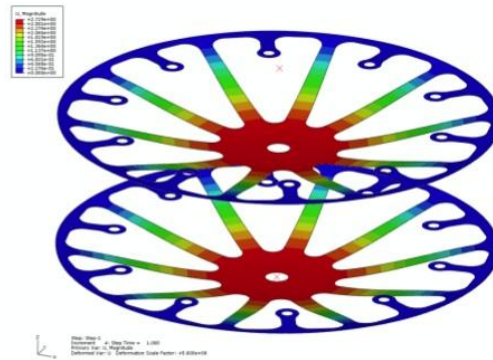

Figure 3.96. Analysis of the flat springs under operational loads.

The lateral displacements under load are very small (8 μm for a 50 N load) ensuring that the position actuators only act axially with respect to the back surface. The overall performance simulation of the segment subunit takes into account all three actuators.

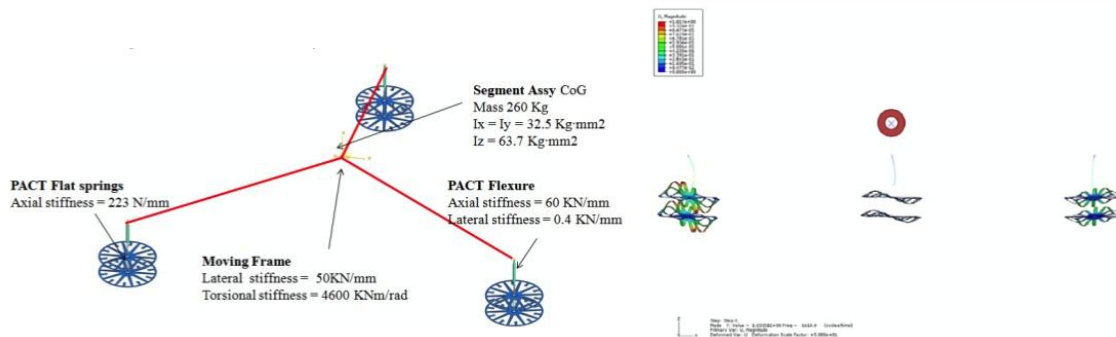

Figure 3.97. The model used for the analysis of the influence of the actuator stiffness and the seventh eigenmode of the support including the actuators at 1620 Hz.

The first three modes of the segment unit in this configuration are found at 8 Hz and 13 Hz tip-tilt and piston respectively about the x - and y -axes. These modes can be controlled by the actuators. Higher order modes that would introduce lateral or torsional errors into the subunit are above 43 Hz.

The position actuator has two operating regimes. Slewing (presetting) speed of $250 \mu\text{ms}^{-1}$ that is used to reposition the segments after a preset of the telescope to a new target and a tracking rate of $1.2 \mu\text{ms}^{-1}$. The regimes are used to calculate lifetime and Mean Time Between Failures (MTBFs) for the actuators and the power consumption of the units.

The actuator power consumption by components within the housing is considered critical as it results in heat dissipation directly under the segment. Power that is consumed by drive electronics and processing and that can be at some distance from the segment may be cooled. The power consumption, during the preset, is dominated by the brushless motor that uses just under 1 W and the total power is just under 1.2 W, including the encoder readout. An additional 1.4 W is taken by the drive electronics. In tracking (where the position actuator spends the most time) the power consumption is still dominated by the brushless motor but is now just under 0.3 W. The total consumption, including the voice coil and encoders is just below 0.6 W.

The prototype systems are under test and are showing promising results.

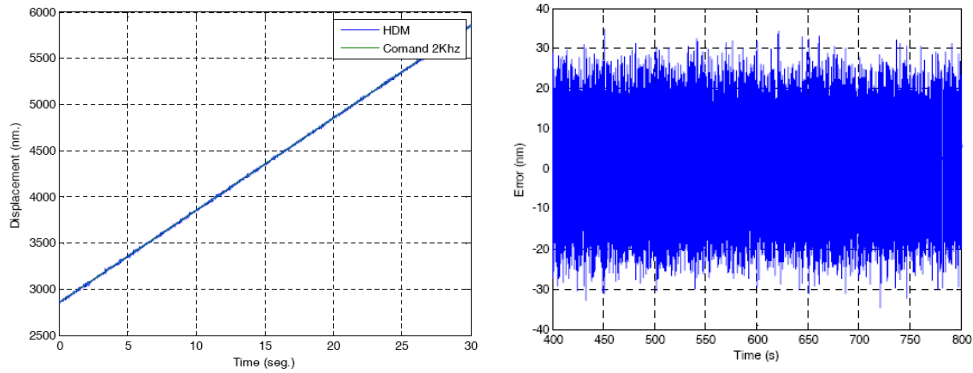

Figure 3.98. Lab measurements of the actuator tracking a ramp of 100 nm s^{-1} over several minutes. Left: Snapshot of the absolute measurement using the internal Heidenhain encoder. Right: The residual of 7.31 nm rms , including the major contributions from the lab environment.

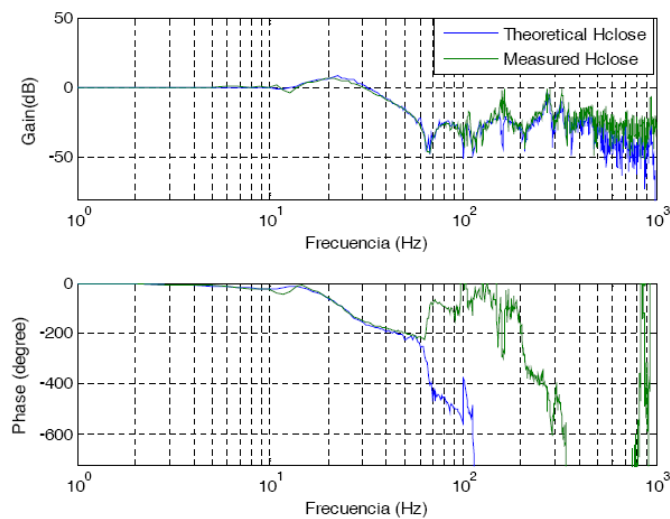

Figure 3.99. Measured closed-loop transfer function of the actuator with an equivalent segment mass attached.

The prototype system has been shown to be compatible with off-the-shelf systems such as PXI by National Instruments and the project does not expect (see section on Control) to need to develop any hardware to drive the actuators.

3.4.5 EDGE SENSORS

Inductive edge sensors from micro-Epsilon form the baseline for the project. The sensors detect piston, gap and shear. The requirements on the edge sensors are to be able to measure piston with a resolution of 0.5 nm over a range of $\pm 200 \text{ }\mu\text{m}$ with a repeatability of 1 nm and a noise level of $1 \text{ nm}/\sqrt{\text{Hz}}$. The shear and gap measurements are required to have a resolution of $1 \text{ }\mu\text{m}$ and an operation range of $\pm 1 \text{ mm}$ with a repeatability of $10 \text{ }\mu\text{m}$. In addition, to enable the fast integration of new or recoated segments into the primary mirror, the edge sensors have a capture range of $\pm 1 \text{ mm}$ with a somewhat reduced resolution of 10 nm . Long-term stability, affected mostly by environmental conditions, is important in order to keep the calibration time of the telescope to a minimum.

Of particular concern to the project has been the maintainability of the edge sensor system. With over 6000 pairs installed on the segments and an average of two segment exchange operations per day the risk of damage to glued blocks of glass on the segments has been considered high. The baseline approach is to establish an accurate interface on the backside of the mirror and to attach and detach the edge sensors. The advantage is that the edge sensor is protected while the disadvantage is that the installation accuracy of the edge sensors becomes more challenging.

The edge sensors consist of the calibrated pair of sensors (an emitter with a single with ceramic boron nitride coil and a receiver with two coils). The sensors are mounted on the back side of the segment using an adjustment system, also ceramic, that permits all six degrees of freedom to be modified. Boron nitride has a similar density to glass and a low thermal expansion coefficient. It is however, significantly cheaper and easier to work with than glass ceramics. The entire design is metal free. All coils are made of low temperature co-fired ceramics with embedded silver palladium conduction paths.

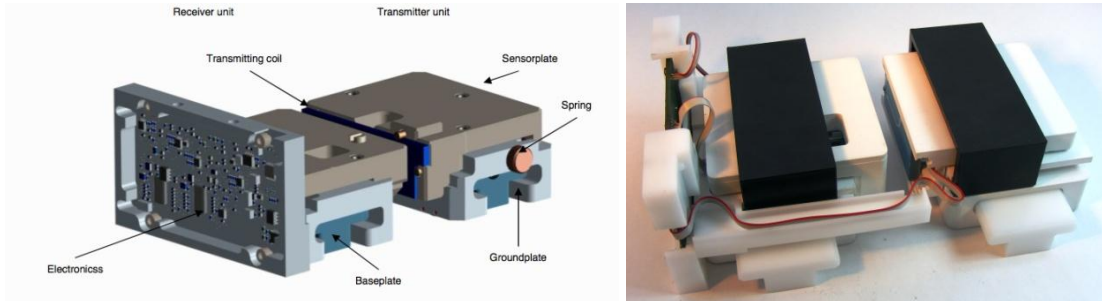

Figure 3.100. Left: Edge sensor components. Right: Prototype edge sensor devices.

The electronics are built into the receiver system and a digital output is generated. Electrically and electronically the edge sensors are by design capable of delivering the required performance. The prototype systems have been measured electrically against a fixed interface and the performance meets ESO specifications.

	pp noise at 1000 Hz in nm	rms noise at 1000 Hz in nm	Resolution in nm/√Hz (@1–1000 Hz)	ESO resolution requirements in nm
Piston 1 (measuring)	14	4.8	0.440	< 0.5 ... 1
Piston 2 (capture)	70	22	2.21	< 10
Gap	86	28	2.72	< 1000
Shear	38	14	1.20	< 1000

Table 3.6. Piston, shear and gap noise measurements from the prototype edge sensors.

The uncalibrated sensors are already linear to 0.2% and with a simple second order polynomial reach the absolute linearity requirements of 0.1%. Additionally the crosstalk between gap and shear and gap and piston are also very close to the specifications before calibration.

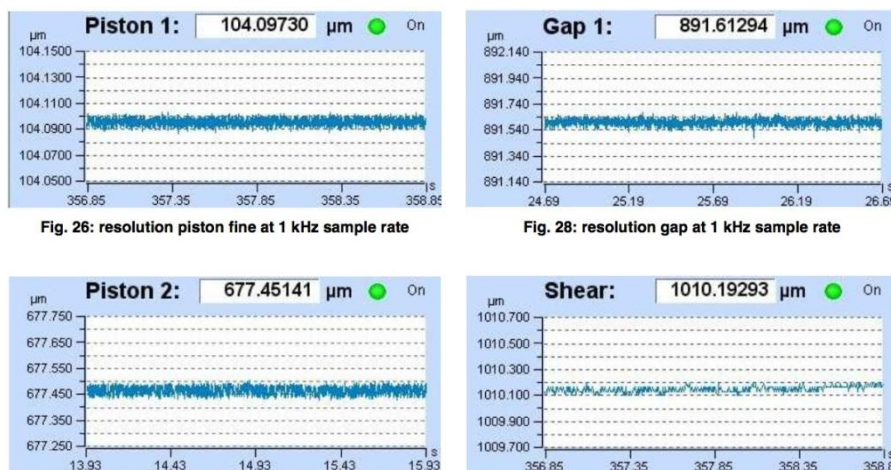

Figure 3.101. Piston, shear and gap noise measurements from the prototype edge sensors.

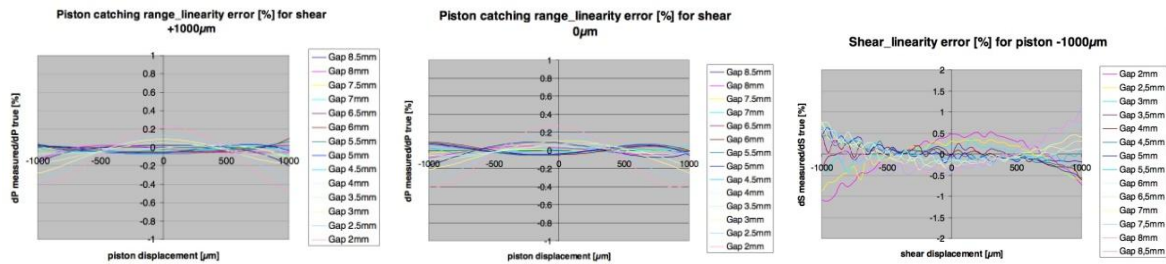

Figure 3.102. The linearity measurements of the edge sensors.

The temperature stability of the device has been measured in a climatic chamber and has been shown to be $< 100 \text{ nm}$ for a 10°C change, in compliance with the upper range of the ESO specification of $5\text{--}10 \text{ nm}/^\circ\text{C}$. The stability of the electronics already at the prototype Printed Circuit Board (PCB) stage is very close to ESO's requirements and the final ceramic electronic board is expected to further improve these values. By moving the electronics on board the edge sensor and providing a digital output the edge sensors become a relatively easily replaceable and controllable component. The drawback is that an additional 0.5 W per edge sensor are dissipated in close proximity with the segment (400 mW in the analogue readout and 100 mW for digitisation).

The choice of paired sensors does provide some complications with respect to mounting procedures and alignment that are addressed below. The integration of the edge sensors onto the segments and the long-term stability and reproducibility of the mechanics has received much attention.

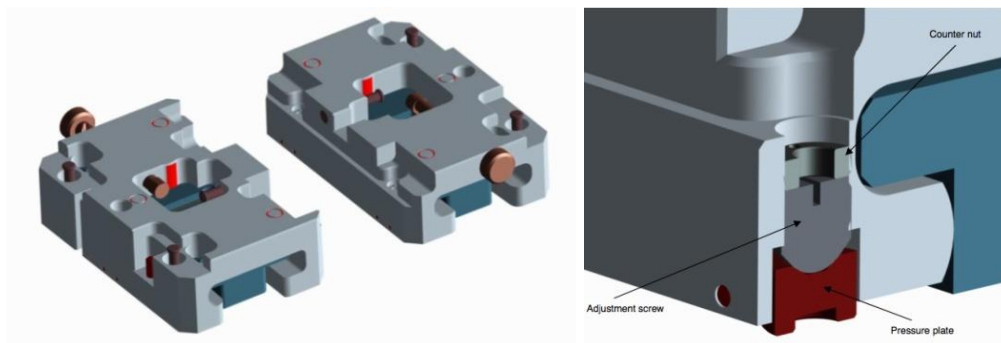

Figure 3.103. The groundplate mounted on the baseplate and adjustment mechanism.

The edge sensors have to be removable from the segment for recoating or due to damage. In addition the accuracy required of the sensors implies that the thermal expansion of any glue used to mount the sensor on to the glass would violate the stability specifications.

These issues are addressed in the design of the mount of the edge sensors. A ceramic rail, the baseplate, is glued onto the segment, referenced to the pads that define the geometry. A ceramic carriage, the groundplate, is then mounted on the rail and is pre-loaded pushing against the glass substrate. The force required is minimal as the preload only compensates for the expansion of the glue. Absolute metrology using a CNC machine defines the interface of the carriage with respect to the front surface of the mirror. The sensor plate is then mounted on the groundplate ensuring the absolute repeatability of the system.

The emitting sensor plate is located on the groundplate using a positioning stop and a centring pin. The receiver is centred using two chamfers and a spring.

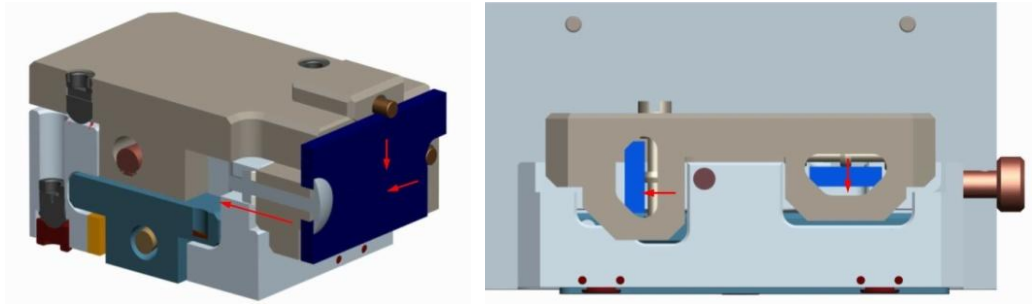

Figure 3.104. Emitter and receiver sensor-plate mounting on the groundplate.

In combination with the exceptional accuracy of the edge sensors the precise mounting should permit a rapid integration of segments after recoating into the telescope optical system.

The procedure for the installation of the baseplate rails on the segments has been established by micro-Epsilon together with ESO and has been iterated with Sagem who have attached the edge sensor baseplates on four of the polished segments with excellent precision ($\sim 20 \mu\text{m}$ absolute with reference to the segment coordinate system).



Figure 3.105. Baseplate prototype integration at Sagem.

3.4.6 M1 CONTROL STRATEGIES

The primary mirror control strategy has been developed, taking into account wind disturbances, sensor noise (edge sensor and the embedded position actuator sensors), changing gravity, thermal expansion and vibrations.

Several control strategies were evaluated at ESO and by an external study with the University of Liege. In the trade-off analysis between global, modal, local and the LTSI (Linear Time and Space Invariant) modal control forms the baseline. Within this baseline the segments are commanded in piston/tip-tilt to reduce cross-coupling at the segment level. For the development of the control strategy the position actuators were assumed to have high stiffness. The stability analysis was subsequently undertaken showing that a variety of actuators (“soft” or “hard”) could be used within this context. The edge sensor loop used a modal control with low bandwidth at low spatial frequencies that suppresses the possible amplification of noise from the edge sensors. The high spatial frequency modes of the primary are controlled with a 3 Hz bandwidth.

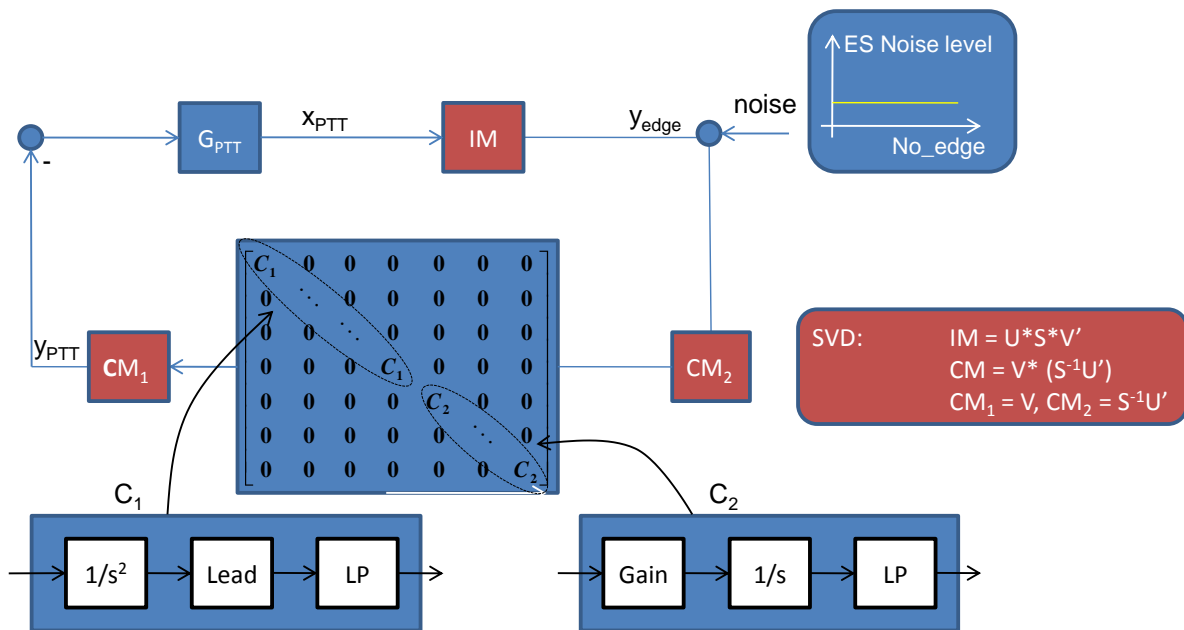

Figure 3.106. Closed loop control, different controllers for different spatial frequencies.

Any strategy that addresses 798 mirrors with almost 2500 actuators and 5000 pairs of edge sensors needs to be investigated for robustness. Four critical effects have been considered. The segments are not infinitely stiff and in particular the supporting whiffletrees have eigenfrequencies at the 35 Hz level. The edge sensors will exhibit noise at a level of $1 \text{ nm}/\sqrt{\text{Hz}}$ and the resolution and noise of the position actuators taken into account. The current specification of 1.7 nm rms tracking error encompasses the sensor noise as well as the offload between the coarse and fine stages of the actuator. Finally the uncertainty in the interaction matrix can lead to instabilities. A study commissioned by the project office with the University of Liege has shown that by introducing a leakage term into the system (effectively a low-frequency low-pass filter in the place of an integral gain term) the robustness of a modal control scheme can be improved significantly.

Simulations of the proposed scheme with realistic data for the stiffness of the position actuators and the disturbances of the system have shown that the performance requirements of 10 nm rms wavefront after the correction by the adaptive mirrors can be met. Before the correction of low- and mid-spatial frequency errors by the adaptive mirror the residuals are of order 600 nm and therefore well within the range of the adaptive mirror to control.

By adopting the modal control, the stiff segments can be driven to provide good wind rejection even for the relatively small bandwidth of the edge sensor loop. In addition, the poor observability of low spatial frequency modes by the edge sensor loop can be taken into account without sacrificing the performance for all scales. The underlying assumption is that the position actuators supporting the segments can be stiffened with respect to the backside structure by control in the case of the adopted baseline soft position actuator**.

Two significant concerns that need to be addressed: first the low bandwidth in the control of poorly observable modes and the related increase of residuals at these modes, and, second, the induced disturbance of the segment by the back structure.

** For a hard actuator this is not an issue.

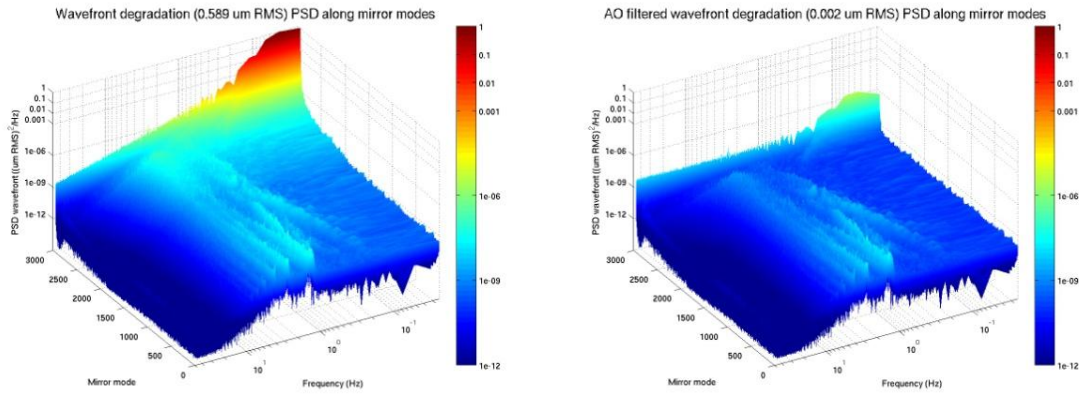

Figure 3.107. Frequency distribution of WFE (before and after adaptive correction).

For both concerns simulations have confirmed that the increase in the Wavefront Error (WFE) is mainly at low spatial and temporal frequencies. These frequency regions are well matched by the rejection characteristics of the quaternary mirror. The provision of this stroke is taken into account in the budget of quaternary.

For both the position actuator and the edge sensor feedback loops, a theoretical stability and robustness analysis was conducted considering the full interaction of the system including the underlying support structure of the telescope. The stability of both loops can be demonstrated using a criterion employing a similarity transformation^{††}.

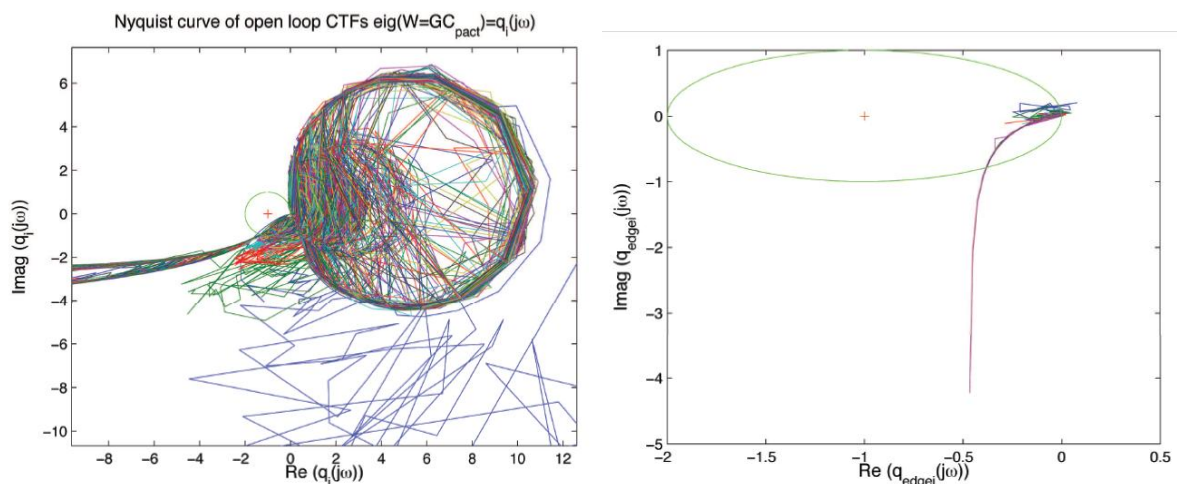

Figure 3.108. Stability analysis for position actuator and edge sensor loops (Nyquist curves).

The performance of the position actuators both in the soft and hard options was evaluated and compared. The performance numbers for wind load rejection were found to be similar for both. In terms of robustness the hard actuator was found to be better as the bandwidth necessary for control in the position actuator loop is lower than the equivalent in the soft actuator case. However, for the purposes of rejecting vibrations the use of a soft actuator is advantageous as its dynamical stiffness is lower at higher frequencies. Especially around 50 Hz, resonances will be better damped and the primary mirror system will be less sensitive to narrowband vibrations.

The control of the primary mirror piston kernel is managed through the introduction of gap and shear measurements in the edge sensor loop. Using these additional edge sensor outputs the piston becomes

^{††} The small gain theorem known from robust control theory could be applied to the edge sensor loop as well, but would fail for the position actuator loop analysis. The proposed solution is robust for both the edge sensor and the position actuator loops.

observable and error propagation due to segment in-plane displacements can be avoided. The edge sensors are only required to measure piston with very high accuracy. The requirements for gap and shear are 1000 times weaker.

The primary mirror control system is the most complex control system of the E-ELT in terms of control hardware. Its architecture was analysed in two independent external studies and some of the main functionalities were verified with a technology demonstrator.

3.4.7 EARTHQUAKE ISSUES

The segments have been included in the global model of the telescope, with their eigenfrequencies, and the analysis shows that even with a non-isolated structure the segments do not individually couple effectively with the earthquake accelerations as propagated by the telescope structure. The accelerations propagated to the segments are 1.4g, 1.2g and 2.6g in the segment coordinates of x, y and z.

As described above the eigenmodes of the mirror units have been analysed and the yield limits of all materials of the segment considered. In all cases the safety margins with respect to the yield strength are positive. Small negative safety margins obtained for the central structure of the moving frame and the tripods of the axial support under coating conditions (thermal load of +70°C) are caused by the specific rigid interface modelling and do not occur in reality.

The absolute and differential motions of the segments in the case of the maximum likely earthquake have been analysed in the context of the soft and alternate hard actuators. A time series analysis was performed including the amplifications of the structure. The absolute motions of the segments are dominated by the behaviour of the structure overall and significant maximum displacements of 117.9 mm in x and y and 61.6 mm in z are found. The maximum absolute rotations, tip and tilt, are 3.4 and 3.5 mrad.

The differential displacements between adjacent segments are 2.43 mm in z and 0.6 mm in x and 0.38 mm in y. The difference between soft and hard actuators in differential displacement is small (2.2, 0.58 and 0.4 respectively for the figures above).

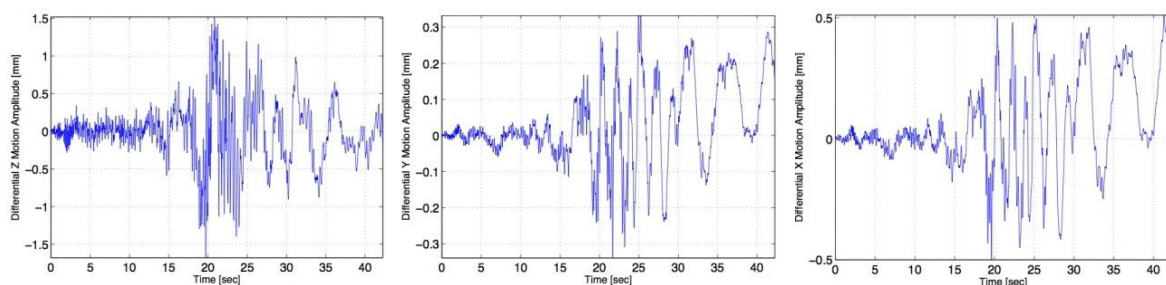

Figure 3.109. z, x and y differential displacements between adjacent segments due to an MLE.

The earthquake analysis assumes there will be no power for the duration of the earthquake so the actuator relies purely on the mechanical stiffness. The Maximum Likely Earthquake (MLE) is applied without the benefit of seismic isolation in the telescope foundations and therefore the analysis is considered conservative.

3.4.8 THERMAL EFFECTS

The effect of temperature on the segment substrate has been considered. The absolute value of the CTE for Zerodur is assumed, conservatively, to be 50 ppb K⁻¹ (parts per billion K⁻¹). An additional term may be introduced from the through thickness gradient of the CTE. Assuming a 1°C difference between the surface and the back side of the mirror the through thickness gradient in the CTE can generate 12 nm of focus. This is a small effect that can add to the noise in the data. The specification for the segment substrates requires the through thickness CTE to be below 10 ppb K⁻¹ or that the orientation of the vector be known. In such a case the through thickness CTE error adds to the segment deformation error system-

atically in the mirror, mimicking scalloping and therefore in principle detectable in the edge sensor loop or on the deformable mirror.

The effect of the change in the back structure of the telescope due to thermal expansion or contraction has been considered within the main structure analysis. While the amplitudes are large the effects are largely in very low order aberrations that can easily be corrected on the active or adaptive mirrors of the telescope during observations and off-loaded to the primary actuators at the time of presetting or during observations.

The heat dissipation under the primary has been analysed with a combination of CFD and Finite Element Analysis (FEA). Our CFD contractor Kirkholm has modelled the airflow above and below the primary mirror. For practical computation time reasons, the volume under the primary has been modelled by a porous structure with parameters adjusted to obtain the same pressure drops as with the detailed (although simplified) segment support structures.

The assumption made was that 15 kW were being dissipated under the primary (15 W per segment).

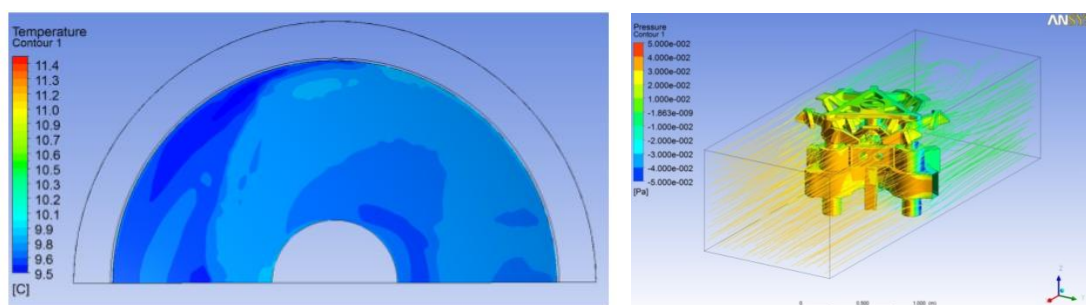

Figure 3.110. Left: Temperature of front face of primary mirror under 2 ms^{-1} wind loading. Right: Simplified segment support used for airflow calculations.

In normal airflow conditions (2 ms^{-1} across the primary) and steady-state conditions, the mirror temperature remained just below the ambient 10°C . This is largely due to the radiative coupling of the mirror to the sky. Another important output of this study has been to define a realistic air speed and temperature below the mirror. In worst case conditions, with mirror horizontal and no wind, a temperature excess of about 2°C with respect to ambient air was computed.

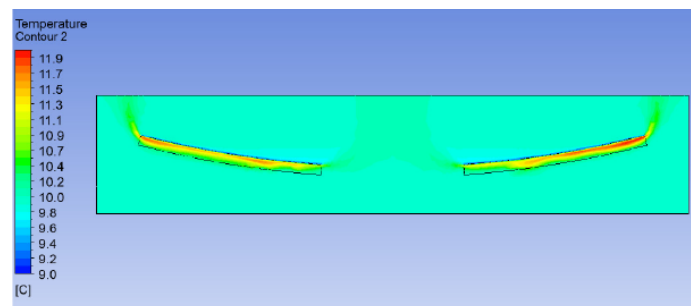

Figure 3.111. Temperature of the air below the primary mirror in worst-case conditions (mirror horizontal, no wind).

This latter result was used in the second, more detailed thermal analysis made on individual segments using FEA techniques. But conservatively connecting the segment to the totality of the thermal load of the actuators and associated electronics, the estimated thermal loads from the edge sensors, actuators and local electronics were applied to the model at their respective locations. A number of load conditions have been analysed to understand the thermal behaviour of the system and perform sensitivity analysis of the various model parameters and assumptions.

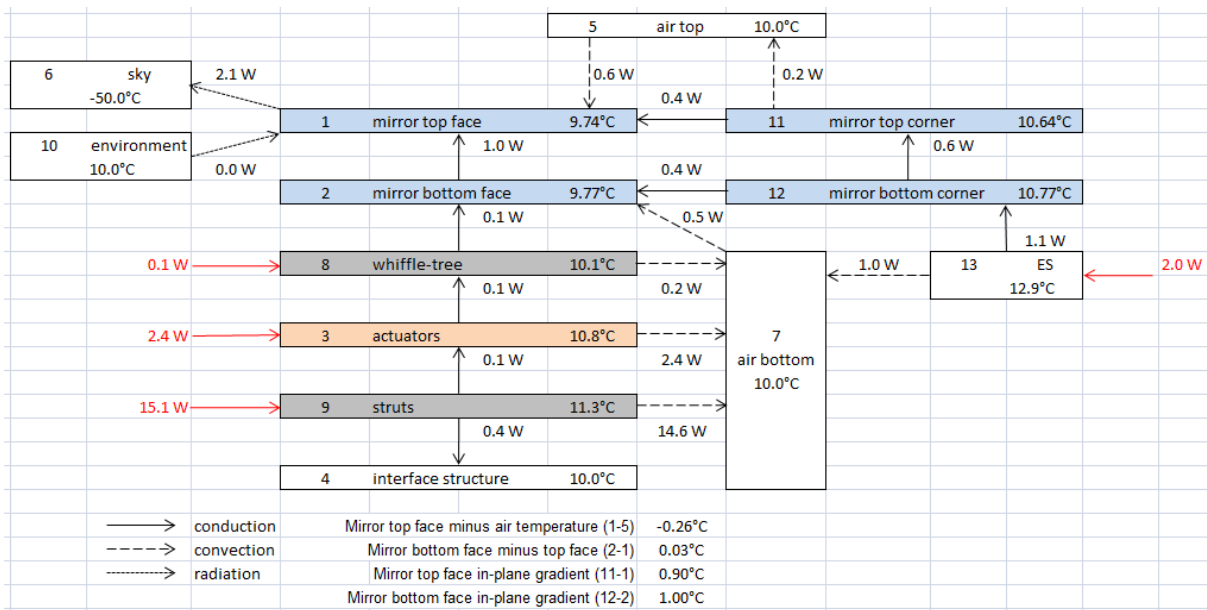

Figure 3.112. Simplified lumped parameter network showing the main of heat fluxes.

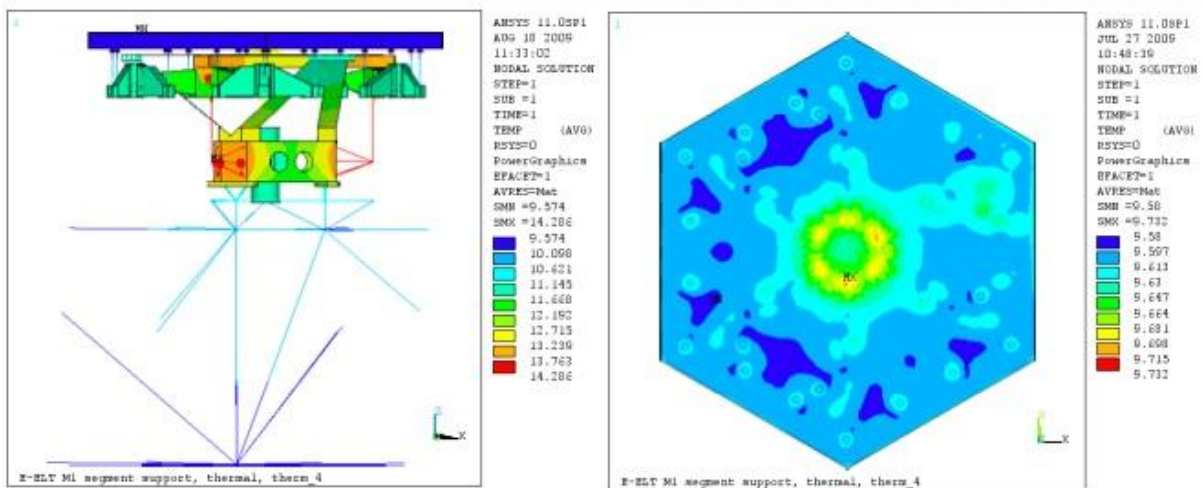

Figure 3.113. Thermal analysis for the segment.

The mirror temperature above the primary exceeds the 1°C difference with the ambient conditions when the temperature of the air under the primary increases significantly (+5°C) with respect to the temperature above the mirror. This reduces the convection cooling of the position actuators and increases the heat transferred through the segment.

As a result of these simulations, the project considers the separation of the drive electronics from the segment unit to be the baseline solution. The analysis is not conclusive on whether the units need to be cooled. Provision for cooling under the primary is available for other hosted units and the total amount of cooling needed is small, although the complication of distribution and risk of leaks provide a strong incentive not to cool.

In addition, transient analyses have been performed to assess the thermal behaviour during a complete daily cycle with air conditioning during the day and passive evolution during the night. An optimisation of the air-conditioning set point during the day (at 10°C instead of 12.5°C in these examples) enables the temperature excess at the end of the night to be reduced at the price of a higher negative difference during the first few hours of the night.

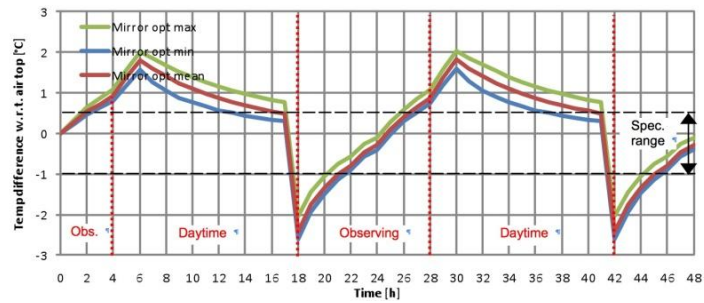

Figure 3.114. Transient thermal analysis for individual segments in a no-wind analysis.

3.4.9 CHALLENGES

As for all sections of the construction proposal this subsection does not represent the detailed risk register, but rather, a more qualitative description of the high-level risks the project has considered for this unit.

3.4.9.1 MANUFACTURING

Multiple manufacturing issues raise their head in the context of the primary mirror. Most critical is the possibility that the length of time needed per segment is higher than the prototyping activities have suggested, resulting in a significant delay in the project and increased costs to the suppliers.

Two programmatic critical interfaces are considered.

The supply of the blanks to the polisher is an obvious risk. The volume of glass required for the E-ELT is significant but not outrageous, corresponding to a year's production for most of our suppliers. Spread over a few years this risk is assumed manageable.

The second critical interface is the provision of whiffletree supports to the polisher to integrate before the ion-beam runs. The supply of the all the 931 supports is considered by the manufacturers to be less than two years of production. This is also not considered to be on the critical path.

Technically the interface that is considered most risky is the sheer number of pads. With over 30 000 pads required to last over 50 years the MTBF is high impossible to achieve or verify. The maintenance of the segments will include the inspection and verification of the pads every 18 months.

3.4.9.2 PERFORMANCE

An incorrect prescription polished into all segments would be problematic. The risk has been analysed and the most likely, and common, error would be that the radius of curvature would be incorrect. This error can be corrected by using some part of the stroke allocation on the other active mirrors. Even if not corrected the error would amount to a change in focal length of the telescope and some degree of field aberrations. This analysis assumes that the mean value of the radius of curvature is incorrect but the dispersion remains within specification. The mean value is to be established during the first production runs. If the dispersion is higher than expected, the project has baselined to use the warping harnesses on the segments to provide the necessary corrections. This would reduce the stroke available for other corrections.

The volume of segments is high and the option of performing a second, independent, optical test on all segments could be complex. The project has ownership of the test setups used during the prototype phase (modulo some existing optics at Sagem) and has access to the Optic Glyndwr complete test setup.

A sensitivity of the edge sensor set points to environmental conditions beyond the current specifications would limit the period of operations between sky calibrations of the primary. The telescope does have a

phasing sensor built into the guide probes and therefore a more regular calibration is possible. The non-selection of this mode as a default is based on MTBF, cost and performance trade-offs.

3.4.10 ALTERNATE SUPPLIERS

In contrast with most chapters of the construction proposal more detail is provided regarding the alternate suppliers, especially in the area of polishing. As mentioned in the construction plan, the project considers that starting production of pre-polished segments as early as possible is a critical area for the supply of segments and therefore alternative suppliers are needed. The project is **not** considering multi-sourcing any of the other supplies such as blanks, actuators and supports.

3.4.10.1 ALTERNATE BLANKS

Alternate suppliers for the M1 blanks are Corning (USA), LZOS (Russia) & Ohara (Japan). All companies have provided price estimates for the supply to the project and to glass polishers directly.



Figure 3.115. ULE polished segment before cutting at Sagem.

3.4.10.2 ALTERNATE SEGMENT SUPPORTS, ACTUATORS AND EDGE SENSORS

For the segment subunits the project has an alternate compliant design/supply from CESA. CESA has designed and delivered three segment supports which were integrated with the segments and successfully finished figured by ion-figuring.



Figure 3.116. Components of the CESA design for the segment support and prototype system.

For the actuators the project has an alternate design/supply from Physik Instrumente. Hard actuators were developed and successfully tested by Physik Instrumente. A soft actuator has been derived from their initial design and is being manufactured at the time of writing.

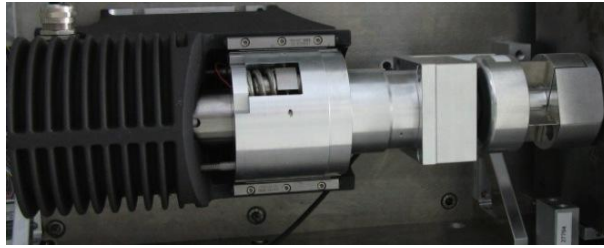

Figure 3.117. Physik Instrumente actuator under test.

For the edge sensors the project has an alternate design/supply from Fogale. The Fogale edge sensors have been used during the Framework Programme 6 on the Wind Evaluation Breadboard (WEB) built by the IAC. The edge sensors are inductive and have shown good performance during the WEB work.

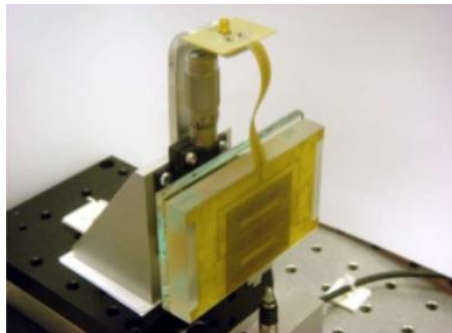

Figure 3.118. Fogale edge sensor under test in the lab.

3.5 SECONDARY UNIT

The convex 4-metre-class secondary mirror is a thin meniscus. Its shape is actively controlled with 84 axial force actuators. Laterally the mirror is supported by eight pneumatic jacks in its centre and by 24 pneumatic jacks along the periphery.

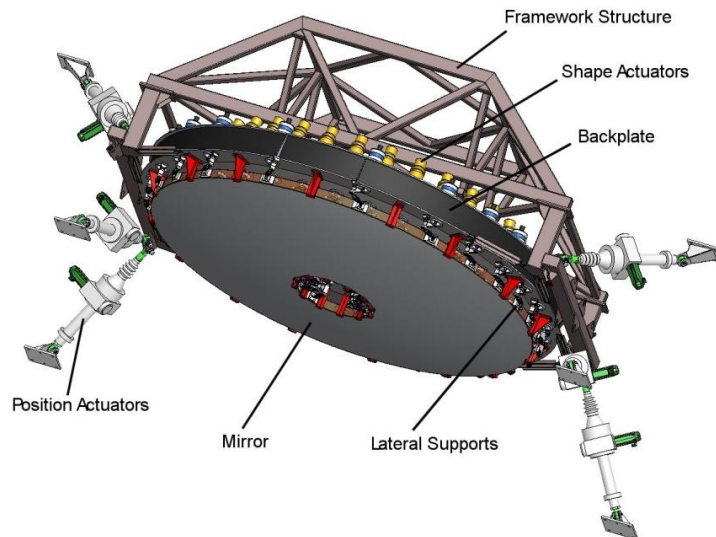

Figure 3.119. M2 unit.

As a baseline, the adjustment of the secondary mirror position is not allowed during an exposure (i.e., while the telescope is observing its target), in order to avoid strong wavefront jumps and to limit power dissipation.

The adjustment of the secondary mirror shape is performed at a low temporal bandwidth, typically at the beginning of an exposure by sending a set point to its active degrees of freedom, and every 20 to 60 seconds to compensate for optical surface distortion induced by environmental conditions, external loads, and system instability.

The mirror and its actuators are connected to a backplate and a framework structure. To provide the mirror alignment function, the whole assembly is moved with respect to the structure by six position actuators distributed in a modified hexapod geometry.

3.5.1 PERFORMANCE REQUIREMENTS

The optical design prescribes a radius of curvature at the vertex of -9313 ± 25 mm, a nominal conic constant of -2.28962 , and fourth power aspheric coefficient of 0.479584×10^{-15} .

The matching of the secondary to the primary requires knowledge of the absolute value of the primary mirror radius of curvature that will be known after the first set of segments have been aspherised. This constraint is considered in the overall schedule. The final conic constant will be calculated accordingly.

The secondary is an active mirror and the specification provides for 30 nm rms wavefront error (excluding the gravity print-through) and after perfect removal of no more than the first 30 eigenmodes. The high spatial frequencies will be no more than 20 nm rms in a footprint of 200 mm diameter and no more than 16 nm rms for footprints of 60 mm. The differential deformation due to print-through of the support into the mirror between zenith pointing and 20 degrees of altitude is required to remain below 25 nm wavefront error.

The final shape of the mirror under active optics (shape control) needs to be within 2% of the command or 50 nm rms wavefront error, whichever is the smallest. The secondary mirror is required to limit the drift of the mirror shape to less than 35 nm rms wavefront for a minimum of 30 seconds.

The secondary unit, mounted on an infinitely stiff telescope structure, should have a first eigenmode at 10 Hz. The absolute accuracy of the positioning system for translations needs to be within ± 0.1 mm and the relative accuracy at level of the mirror within 2% of the absolute accuracy.

The total mass of the unit shall remain below 12 tonnes with goal of 10 tonnes.

3.5.2 MIRROR BLANK

The useful area of the secondary mirror is annular with the inner diameter at 1091.0 mm and the outer at 4090.6 mm. Mechanically, 80 mm are provided as polishing margin on rims.

The mirror blank dimensions have been selected to provide sufficient stiffness in the substrate to be able to polish and support it with a small (25 nm rms wavefront error) print-through from the support, to allow active shape control with minimum force and power dissipation, and to minimise its sensitivity to external loads.

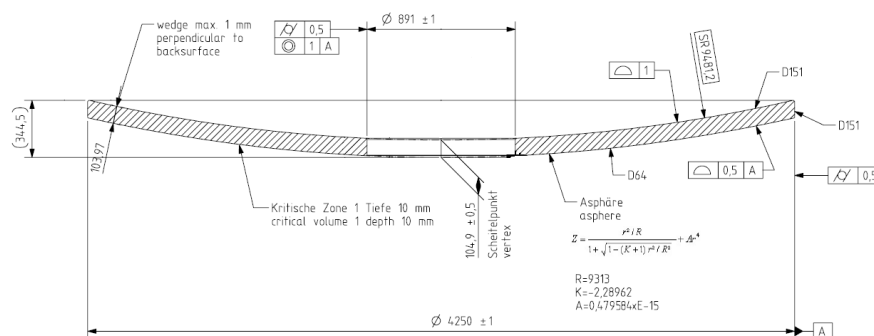

Figure 3.120. M2 mirror blank.

As for the tertiary, the adopted baseline solution is to procure the secondary blank from Schott. The blank fits with the existing production facilities. They were, for instance, used to produce the VISTA primary mirror 4-metre blank.

The machined blank from Schott will be delivered with a surface deviating from the required asphere by less than 0.5 mm.



Figure 3.121. Schott 4-metre blank. Left: Casting. Right: Finished product (Courtesy Schott).

3.5.3 POLISHING

The secondary mirror polishing is challenging, not least because it is convex. While it would be nice to consider alternate options the only realistic solution is that the mirror is polished and tested face up. As a minimum this means that the support print-through will double when the mirror is mounted in the telescope with the gravity vector inverted.

The plan follows the basic principles developed during the VLT, Gemini and VISTA programmes. The mirror is loaded on a stand and the axial pads and lateral pads will be bonded. The mirror will be ground and pre-polished before the final polishing and optical testing.

The grinding and polishing can be performed using computer-controlled lapping, however the mirror f -ratio (F/D 1.13) and aspheric departure (1.5 mm) reduce the maximum possible size of the lapping tools. The production schedule is therefore longer than for more conventional large mirrors such as the tertiary. In addition, reaching the optical quality requirements in the high spatial frequency range will be more challenging.

A combination of computer controlled grinding and polishing bonnets and laps has been found to be the optimum process optics of such a size by a number of polishers over the years. The overall figuring schedule for polishing remains below two years and is driven by the availability of the metrology rather than the figuring.

Several polishing vendors have machines compatible with the mirror size. In addition to the optical test setup, an active polishing support will need to be developed to allow measuring the mirror in accurate loading conditions and to minimise the gravity and polishing print-throughs.

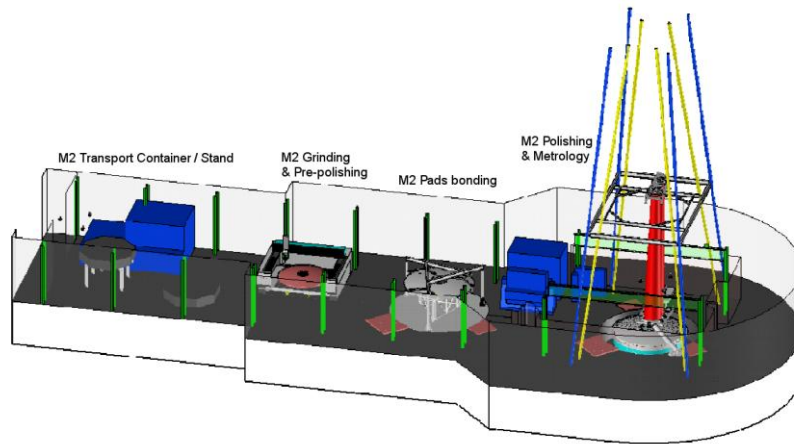

Figure 3.122. Possible M2 polishing workshop — modifications of VLT Primary Mirror workshop (courtesy Sagem).

3.5.4 METROLOGY

For the metrology during the grinding and pre-polishing stage a swing-arm profilometer is planned. The device is based on the units in use at the University of Arizona. A rotating arm is tilted to match the curvature of the mirror and a measurement probe sweeps out an arc that is largely aligned to the mirror while the probe remains normal to the surface of the mirror. A series of circular scans are taken to build a complete surface map. In measuring large aspheric surfaces in Arizona this tool has achieved a repeatability of a few nanometres.

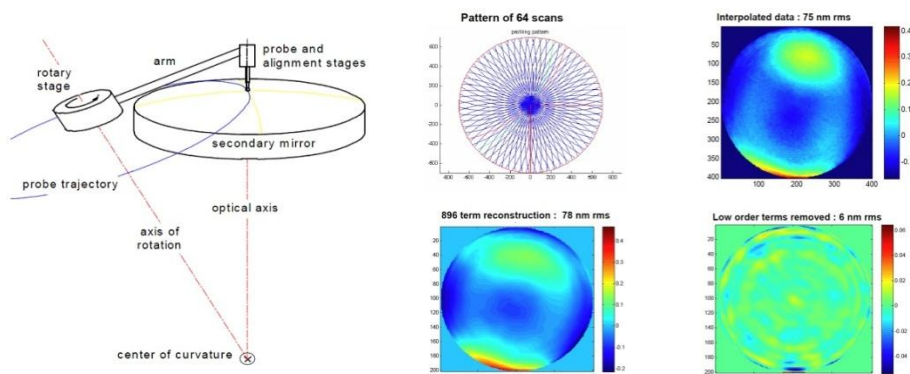

Figure 3.123. Swing-arm profilometer concept and measurement results on a 1.4-metre convex asphere from the University of Arizona.

Extrapolating from a 1.4-metre mirror figured by the University of Arizona to the 4-metre E-ELT secondary, the expected accuracy of the swing-arm profilometer on a polished surface would be approximately 150 nm rms surface error excluding low orders (astigmatism, coma and trefoil). During the grinding phase 50 nm accuracy is considered feasible.

The optical metrology has been studied by several companies. All methods rely on subaperture testing and reconstruction of the full aperture optical quality by stitching. The subaperture tests can be performed using a large reflective 2.7-metre Hindle sphere (Brashear), a Fizeau test using spherical 1-metre transmission matrices and computer generated holograms, as proposed for the primary mirror segments (University of Arizona), or a Fizeau test using 1-metre aspheric transmission matrices (Sagem).

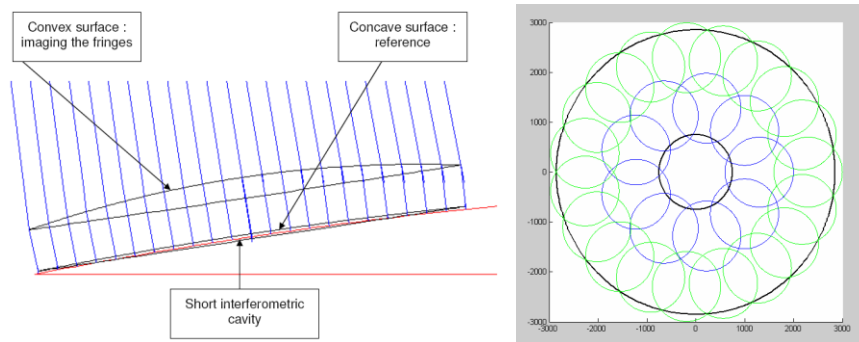

Figure 3.124. Mirror testing using test matrices and stitching.

An advantage of the test methods using transmission matrices is that the interferometric cavity is short (a few centimetres), built from the concave surface of the test matrix to the convex surface of the mirror, thus leading to minimum perturbations due to air turbulence. All methods require about 10 metres of space above the mirror to install large folding mirrors.

The test proposed by Sagem for the mirror is based on a Fizeau test using transmission matrices, similar to that developed for the testing of the VLT, Gemini and the GTC secondary mirrors. In this case Sagem are proposing to use two off-axis aspheric matrices of 1.0-metre diameter and stitch the interferometric results in two rings on the secondary mirror with ten subapertures covering the inner ring and twenty the outer.

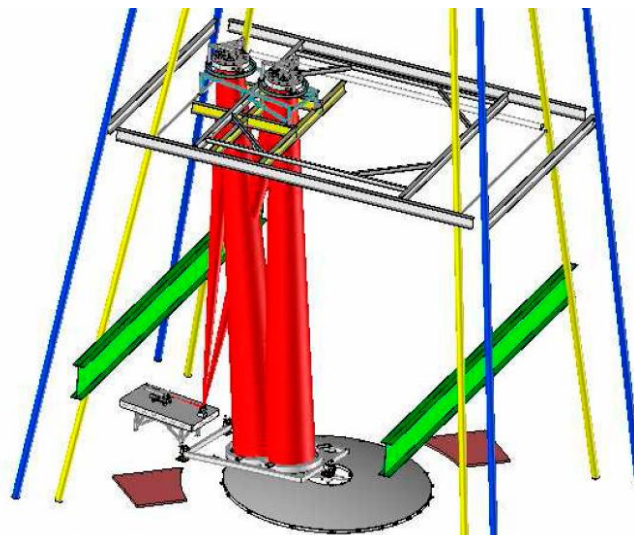

Figure 3.125. Possible layout of M2 mirror testing.

The matrices would be meniscus-shaped and the beam would be folded by two flats at the 10-metre stage of the existing Sagem tower. By folding the test setup all measurements and adjustments (positioning of matrix, usage of the interferometer etc) are on the ground floor and the test procedure can be significantly shortened. The matrices can be made of glassy Zerodur or fused silica.

The alignment errors giving rise to low and high spatial frequencies can be determined with sufficient overlap between measurements and accuracy of test matrix positioning.

The matrices would be manufactured against an interferometric test setup using a CGH and measured mechanically in a 3D CMM providing the required accuracy in the knowledge of the position of the vertex of the matrix and the same accuracy in the knowledge of the radius of curvature.

3.5.5 MIRROR CELL

The adopted baseline for the mirror cell is the design by MTMechatronics.

The cell is made of a back structure made of steel supporting a carbon fibre sandwich plate against which the shape actuation takes place. A steel frame provides the interface for the position actuation of the entire cell.

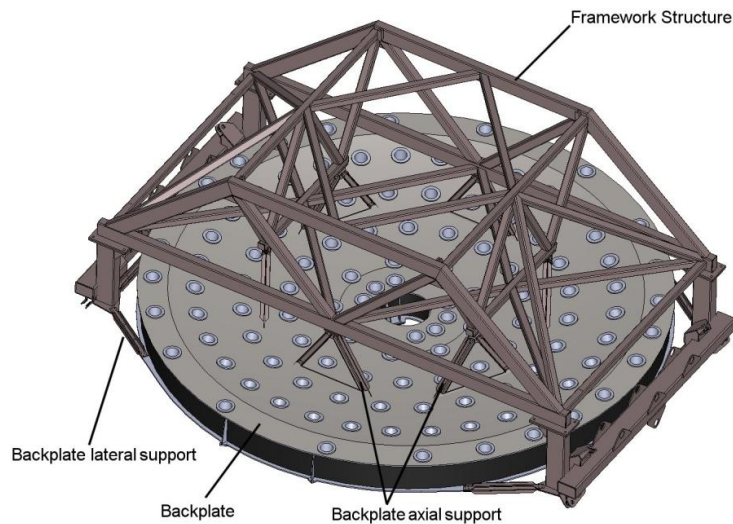

Figure 3.126. Steel framework structure and CFRP backplate.

Carbon fibre was selected for the sandwich structure as its thermal properties match the mirror material better thereby reducing the stroke of the shape actuators. The carbon fibre sandwich has upper and lower Carbon-Fibre-Reinforced Polymer (CFRP) “deck” layers and carbon foam material for the foam. Tube holes provide the interfaces to the actuators.

3.5.5.1 LATERAL SUPPORT OF THE MIRROR

The mirror is supported on its periphery by 24 lateral supports. They are arranged to take the gravity loads and provide support in the y-direction.

They are mechanical cantilever systems incorporating a double chamber pneumatic stage that works in push-pull allowing the same actuator to be used on both the lower and upper side of the mirror. Their support orientation is optimised to minimise the mirror deflection. The double chamber allows the stiffness of the actuators to be adjusted.

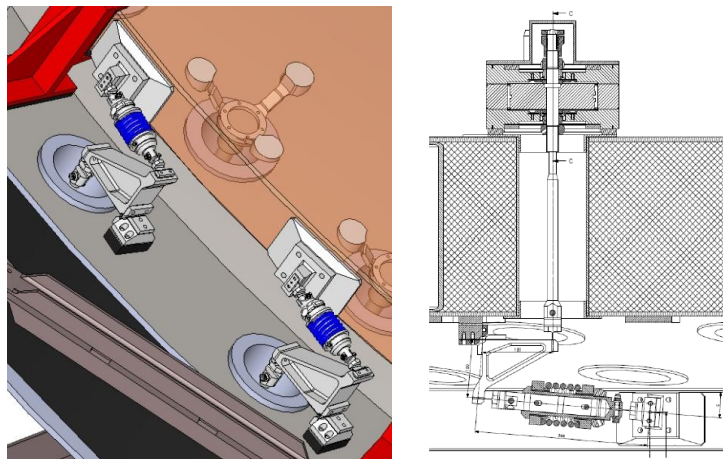

Figure 3.127. Lateral supports.

In order to maintain the position of the mirror relative to the backplate at different altitude angles, a reduced variable pressure is applied to the actuator's air cushions on the opposite side.

Eight additional central supports are installed to provide higher stiffness in the x-direction, especially in case of wind and earthquake. The pneumatic control concept ensures that the reaction forces are equally distributed. During operation the forces at these supports are near zero.

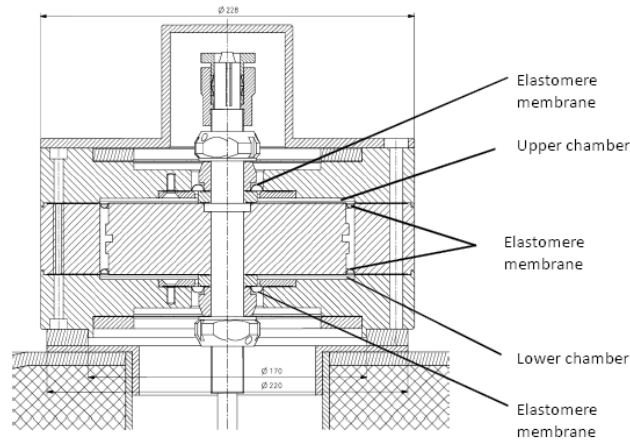

Figure 3.128. Pneumatic actuator. The pressure in the two chambers provides stiffness; the differential pressure between the two chambers allows force adjustment.

Force limiters connect the mirror lateral pads and the lateral supports. During an earthquake the mirror can then “float” and the loads are carried by the earthquake restrainers (see below), avoiding high stress at the support points. The force limiters also protect the mirror from high loads should one pneumatic actuator fail (membrane rupture).

The position of the mirror with respect to the backplate will be monitored in horizontal directions (x-y) with four position sensors on its circumference.

Aberrations arising from the lateral support system have been analysed by locking the force actuation whiffletrees and observing the residual errors (passive mode deformation). The analysis has included temperature, and gravity vector changes, and integration errors. These errors are well corrected by the force actuators.

3.5.5.2 SHAPE ACTUATION

The shape actuators are designed for a mirror-shape maximum residual error of 50 nm rms wavefront error after a force setting is applied. In addition, the shaping system is able to introduce a few micrometres of focus, spherical, astigmatism and coma into the mirror for telescope optical performance optimisation and control.

The actuator concept follows a two-stage design. The first stage is a pneumatic spring carrying the gravity loads of the mirror. The pneumatic units are connected in three pneumatic whiffletree sections. In the second, parallel stage a voice coil actuator produces additional forces to maintain the required mirror surface shape. A load cell allows an accurate closed-loop force control.

In operation the force stroke needed at the level of the whole actuator is 750 N. The force needed at the level of the electromagnetic motor (voice coil) is 150 N. The maximum actuator stroke, mainly driven by the load cell measurement range is 1000 N. The force setting accuracy is 0.1 N.

Following the same principle as for the lateral supports, the shape actuators transmit the force to the mirror via a force limiter, operating at 1000 N. Its function is to protect the mirror in case of failure of the pneumatic spring and to avoid high loads in case of an earthquake.

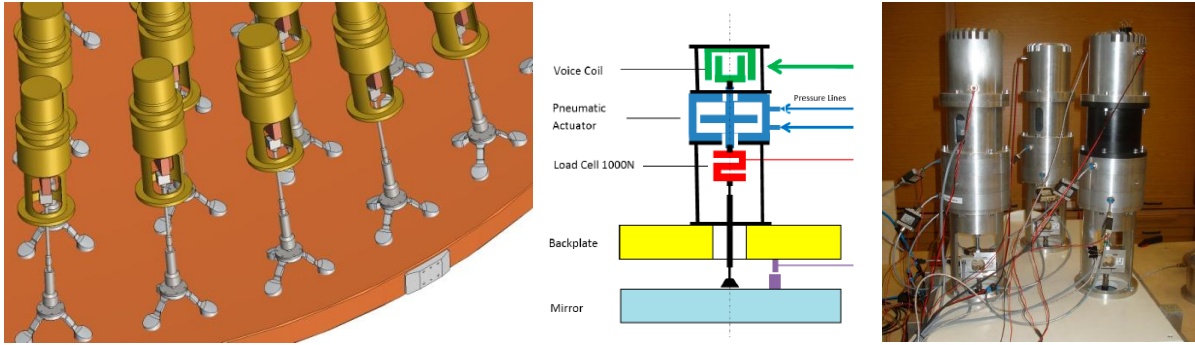

Figure 3.129. Shape actuators.

The pneumatic springs are defined in the baseline concept as active units. While the pressure in one chamber of the pneumatic spring is fixed, the pressure in the other chamber will be varied.

The position of the mirror with respect to the backplate will be monitored in the vertical direction (z) with four position sensors on its circumference.

3.5.5.3 POSITION ACTUATORS

After an extensive trade-off, a worm-gear system has been selected as baseline solution that meets the specification of ± 30 mm stroke, $100 \mu\text{m}$ absolute positioning and $10 \mu\text{m}$ resolution. The angular accuracy is ± 7 arcseconds about the x and y axes with a goal of ± 2 arcseconds.

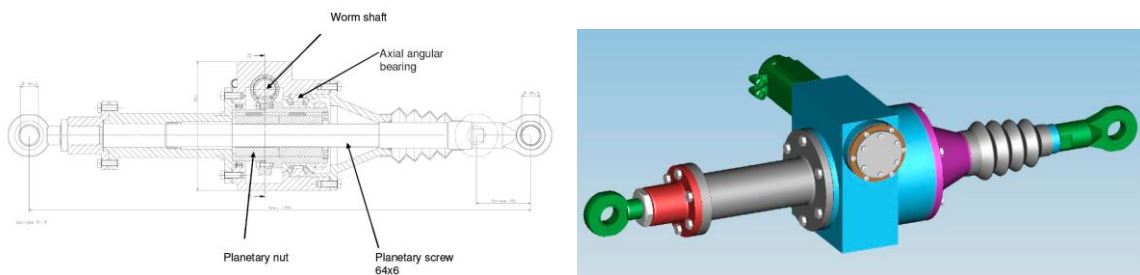

Figure 3.130. Position actuator components and CAD view.

Of particular note is the geometry of the positioning system which ensures that, in operational conditions, the legs do not reverse their operations and therefore avoiding backlash issues by design.

3.5.5.4 CONTROL

As described above the secondary mirror unit baseline design includes several control systems, the positioning system, the mirror shape system and the pneumatic control of the lateral supports. The control analysis provides the synthesis of these.

The positioning system accuracy is not considered to be a design driver and experience by the subcontractor (MTMechatronics) in previous systems (positioning of the 6.5-metre subreflector on the Effelsberg 100-metre telescope) provides confidence in this system.

The control of the mirror shape is significantly more challenging as an accuracy of 50 nm surface error rms within two seconds of actuation is required. Finite element analysis was used to establish that a force accuracy of 0.05 N is necessary to reach the shape specification. This requires the shape forces to be actively controlled, since they cannot be kept stable passively within that accuracy.

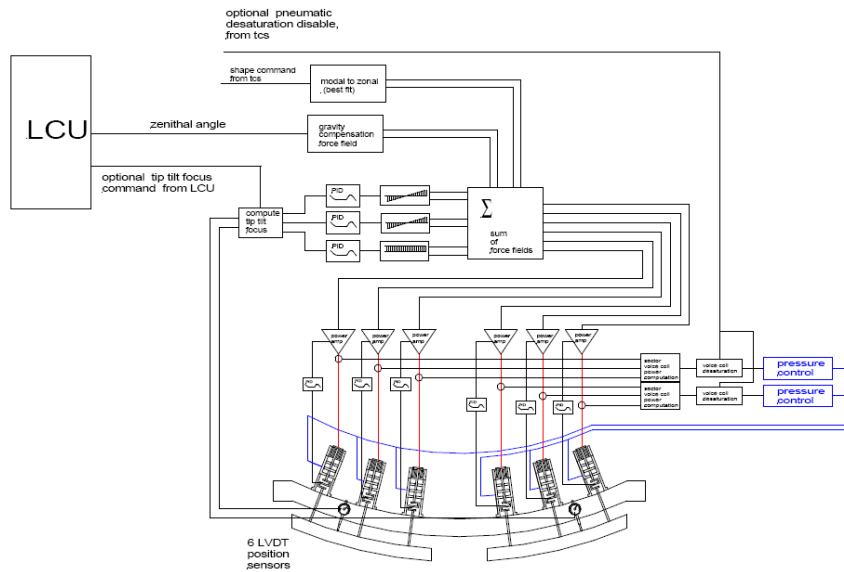

Figure 3.131. Secondary mirror cell baseline control concept — pneumatic whiffletree and separate shape force control.

The baseline mirror shape control concept is based on a nested control structure applying force fields using voice coil force actuators to adjust mirror shape and rigid body tip-tilt and piston.

Additionally, mainly in order to reduce power consumption, the force fields applied by the voice coils are offloaded by the pneumatic actuators connected sector-wise to pneumatic whiffletrees. For this concept it is sufficient to use single force sensors per actuator placed between pneumatic actuator and mirror interface.

The force contribution necessary for mirror tip-tilt and piston control is derived with the help of six contactless position sensors. With this structure, the force control for mirror shaping is free of tip-tilt piston contributions. Position and temperature dependant nonlinearities, drifts and other influences can thus be compensated.

Within the secondary mirror unit FEED study, alternative solutions have been investigated in which individual control of all pneumatic cells is used, bypassing the hardware whiffletree. The whiffletree functionality is created in software rather than hardware. The analysis shows that such an electronic whiffletree could reduce the power consumption of the voice coil actuators as the offloads could be better managed. However, the penalty for such a scheme is in more complex control hardware due to the need to control the individual actuators rather than groups of actuators. The required force transmission accuracy has been proven on an experimental setup and dynamic simulations.

3.5.5.5 THERMAL ANALYSIS

The conventional approach of extracting heat from the unit using a chilled medium was considered particularly risky in the case of the secondary mirror unit. A leak at the location of the secondary could contaminate a large number of segments below resulting in degraded performance of the telescope over an extended period of time.

The secondary unit design is therefore based on passive cooling. The heat budget for the unit assumes 100% utilisation of the shape actuators and a 10% duty cycle for the position actuators.

The shape actuators are expected to consume approximately 120 W average, and 1.0 kW peak, in correcting all errors due to gravity, thermal, test, manufacturing and integration errors. These figures the power consumption of both the pneumatic and electromagnetic actuators and their amplifiers.

Factoring in the duty cycle, the position actuators would consume 80 W with 45 of those at the motor and the remainder at the power amplifiers.

In normal operations, the maximum consumption is considered to be of order 2 kW for the actuation of the cell.

The design of the cell is such that the actuators will be exposed to the wind. It has been calculated that with wind speeds of order 1 ms^{-1} flowing across the actuators their temperature will not exceed 1°C from ambient at zenith and 2.5°C at 70 degrees elevation.

The heat dissipation from the power amplifiers and the other electronic cabinets necessary for the control of the mirror can be achieved using a cold-plate that is assumed to be radiatively coupled to the night sky. Its design is not complete at the time of writing.

3.5.6 EARTHQUAKES

The secondary mirror unit is exposed to significant accelerations during an earthquake. Assuming a non-isolated telescope mount, the peak accelerations at the location of the secondary are $1.7g$, $3.0g$ and $2.6g$, in the local coordinates x , y and z .

Earthquake restrainers are mounted at the periphery of the mirror and in the central hole. These are simple passive brackets with elastoplastic pads (rubber-like) limiting the maximum extent of travel for the mirror to 5.5 mm, absorbing and damping the mirror displacement energy. Contact occurs between the mirror and the earthquake restrainer pads at a mirror at 1 mm displacement.

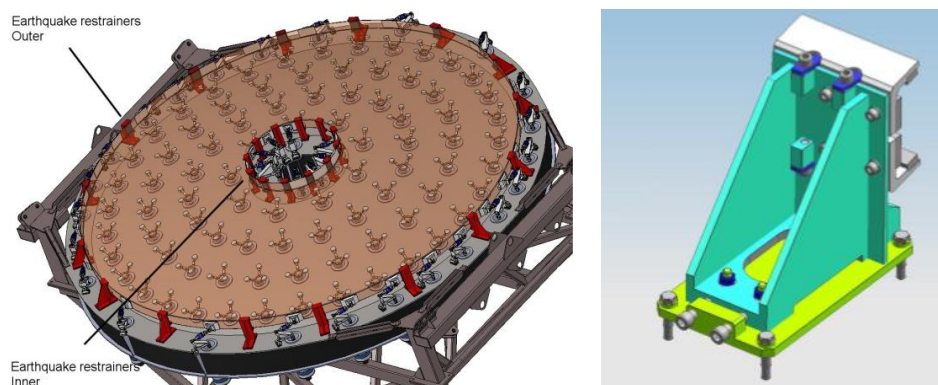

Figure 3.132. Safety restraint for the secondary mirror.

The maximum stress in the glass remains, below 8 MPa admissible tensile stress limit of Zerodur. This condition is met even with three lateral supports and three axial supports missing (e.g., pad glue failure).

3.5.7 CHALLENGES

The secondary mirror hangs upside down and so permanent tensile stresses are present on the mirror surface and in the glue. Failure of this interface would be very unfortunate. The mirror is protected from falling by the safety restrainers and the design of the interface to the back surface of the mirror takes care to reduce the permanent stress level.

3.5.7.1 MANUFACTURING

The procurement of the secondary blank should not be done at the same time as for the tertiary blank. A constraint to this effect is present in the schedule.

The procurement of the matrices for the polishing test setup needs to start early enough to ensure that a sufficient time margin is present in the schedule.

3.5.7.2 PERFORMANCE

The need to produce a secondary mirror unit that does not require active cooling is challenging. A mitigation strategy of cooling part of the unit during the day and creating heat sinks that couple the actuator electronics is an option that can be considered should the passive cooling solution not succeed in meeting the requirements. Alternatively, the cooling with R134 being considered for the quaternary unit may also be a solution to be considered in the case of the secondary, although the logistics would be complex.

3.5.8 ALTERNATE SUPPLY/DESIGN

Corning and LZOS are alternate suppliers for the mirror blank.

For the polishing of the mirror and the manufacturing of the mirror cell, alternative concepts and cost estimates have been provided by Brashear in Pittsburg. Other potential vendors are candidate for the mirror manufacturing, such as AMOS and LZOS. Many vendors can design and provide the M2 mirror cell.

It is worth considering having the design of the M2 unit and of the M3 unit carried out in parallel and possibly by the same supplier. A lot of synergies can be found in the two designs and it is likely that the same shape actuators, lateral supports, back-plate technology and/or position actuators could be used. This would reduce the development costs and schedule, and simplify the maintenance and operation of the systems.

3.6 TERTIARY UNIT

The tertiary mirror is a critical component of the telescope control strategy and performs a critical function in permitting the telescope to achieve a variable focal length. The control strategy requires the tertiary mirror to move instead of the secondary and therefore a flexible positioning system is used to shift the mirror in all six degrees of freedom. The control strategy converts the relative insensitivity of the tertiary into an advantage since, although the strokes are large, the precision of motion is reasonable for a unit of this size with requirements of 0.01 mm resolution in x , y and z and an accuracy of ± 0.1 mm.

The radius of curvature is -21 067.95 mm, the mirror is a mild aspheric with a conic constant equal to zero and moderate fourth and sixth order aspheric terms.

The residuals of the active optics are required to be less than 20 nm rms wavefront error and the shape correction is required to be able to correct the lowest 11 Zernike modes with a residual of 30 nm rms.

Additionally, the tertiary mirror cell is required to passively maintain the mirror shape, allowing a maximum error of 20 nm rms for over one hour (excluding gravity and external thermal variations).

3.6.1 CONCEPT

The tertiary mirror unit is based on a thin meniscus active mirror. The thickness of the mirror, approximately the same as that of the secondary mirror, was selected to provide the relative flexibility of the mirror required to modify its shape when controlling the focal ratio of the telescope with moderate active shape control forces.

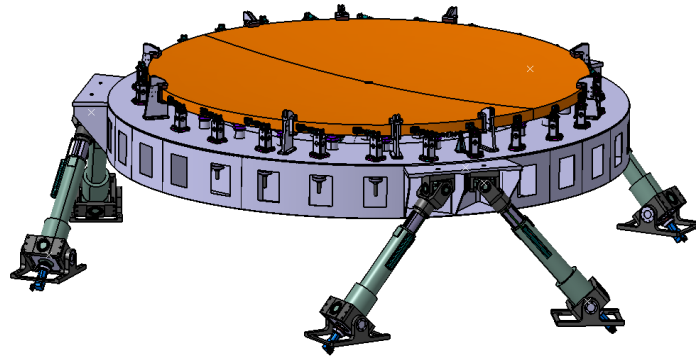

Figure 3.133. Concept of the M3 unit.

The unit consists of the mirror, the cell, six position actuators, 57 axial active supports, three axial fixed points, six axial reference points, three centring reference points, 24 lateral supports, three lateral fixed points and 14 outer axial restrainers.

3.6.2 MIRROR

The tertiary mirror is 3.75-metre across and 100 mm thick with an 80 mm diameter hole in the centre.

The dimensions are within the existing production capabilities of Schott and can be delivered within one and a half years of an order being placed. According to the baseline design of the support structure (see Figure 3.134) the blank is to have pockets machined on the back surface to provide a mechanical interface to the mirror that is in the XY-plane of the mirror.

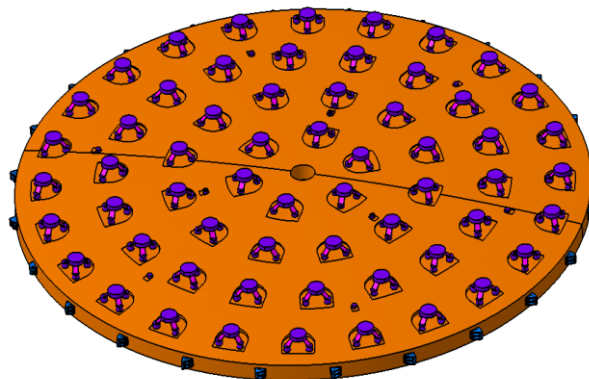

Figure 3.134. Back-side interface tripods on the mirror.

3.6.3 POLISHING AND TESTING

The M3 mirror optical departure from a best-fit sphere is in the order of 26 μm peak-to-valley. Such a low aspheric departure allows the use of quite large polishing tools to figure the mirror and hence to achieve a smooth optical surface in a relatively short time.

Designing and building a full-aperture optical test setup is relatively straightforward. A common interferometric test at the mirror centre of curvature can be performed using a null corrector such as a classical Offner or CGH.

The only difficulty is the large length of the interferometric test cavity (21 metres). Depending on the selected polishing vendor, the optical beam might have to be folded with a flat mirror, typically 1 metre for a 15-metre-high test tower.

The tertiary mirror procurement and polishing is not considered to be a high risk.

3.6.4 THE CELL MECHANICAL DESIGN

The AMOS design for the tertiary mirror cell is adopted as the baseline design. The entire tertiary unit has a mass of just over 12 tonnes. The mirror cell is a stiff box-like steel structure with a steel plate supported on ribs providing the mounting location for the axial supports that follow the curvature of the back surface of the mirror.

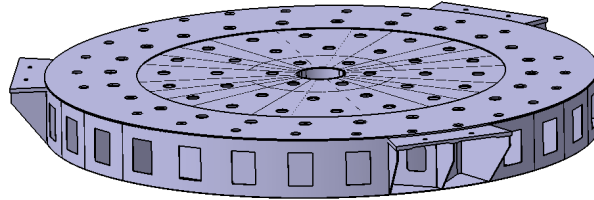

Figure 3.135. Mirror cell basic structure.

The weight of the mirror cell alone is 5100 kg. The finite element modelling shows a maximum deflection of 0.42 mm when the cell is loaded with the mirror. Approximately half of this deflection arises from the mirror cell itself.

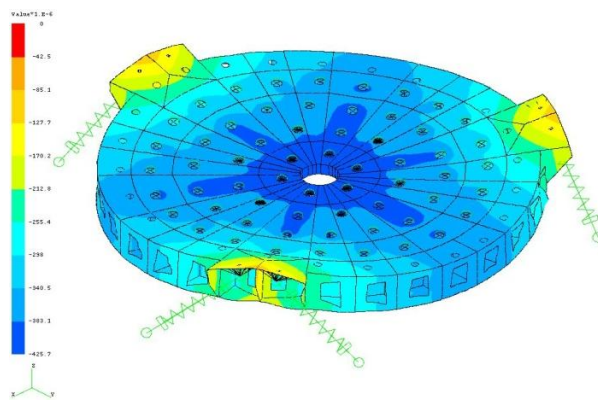

Figure 3.136. FEA modelling of the mirror cell and supports.

The mirror is referenced with respect to the cell using fixed points. Six additional supports are used to distribute the weight and to avoid mirror overload. In operational conditions, the three lateral and the three axial fixed points have non-linear properties due to the preloaded soft springs, thereby providing high stiffness for operational loads while limiting the maximum loads in case of accidents or earthquakes.

3.6.5 AXIAL SUPPORTS

Sixty actuators are located on four rings, three of the outer 24 actuators are passive and are used to define the position of the mirror relative to the cell. The actuator interface to the mirror back surface is through a load-spreading tripod. Invar pads connect the tripods to the mirror.

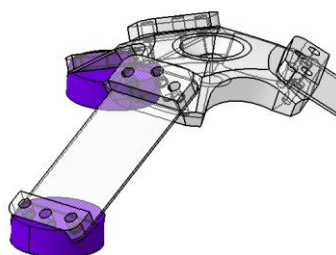

Figure 3.137. Detail of the tripods.

The actuator design is based on a pneumatic double chamber concept that permits push-pull operations. The actuator provides 1 kN of force and the load cells provide an accuracy of 0.2 N.

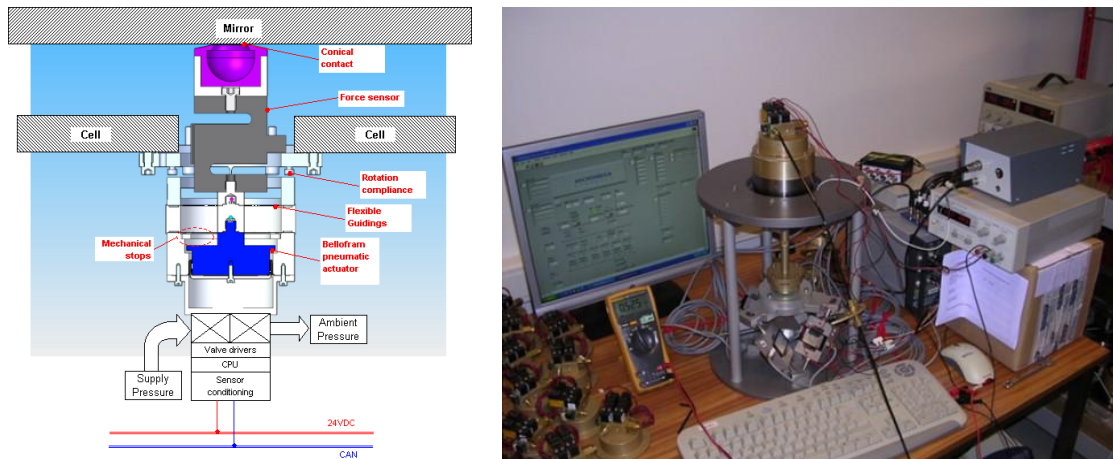

Figure 3.138. Conceptual design of the pneumatic actuator and prototype in the lab at Micromega (B).

A prototype actuator has been manufactured and successfully tested by Micromega Dynamics (B).

3.6.5.1 LATERAL SUPPORT

The lateral supports of the tertiary mirror are 24 astatic levers and three lateral fixed points. As for the secondary mirror, they follow a Schwesinger distribution.

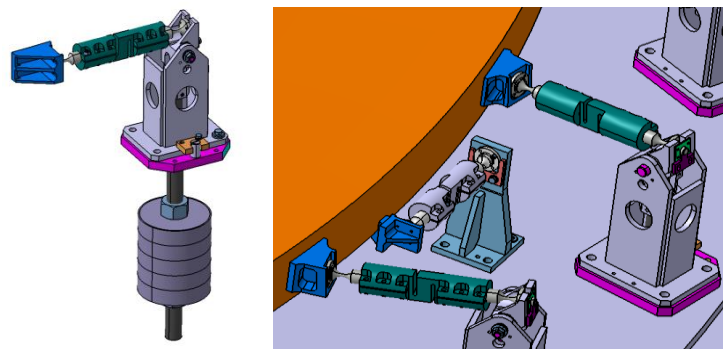

Figure 3.139. Astatic level design and the lateral supports and fixed points on the tertiary mirror.

Excitation of the astatic levers determines the lowest eigenfrequency for the global mirror cell and mirror system. The first modes are at 8 Hz and 16 Hz and consist of a lateral motion of the mirror against the astatic levers, while the mirror cell is not moving.

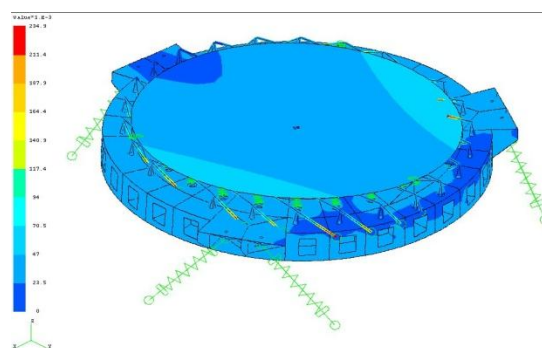

Figure 3.140. First mode of the system at 8 Hz.

Fourteen outer axial restrainers are used to limit the displacements and accelerations due to earthquakes. These are simple brackets with Philan pads located 100 μm axially and 1.1 mm radially from the

mirror. The design is very similar to brackets used in the secondary mirror. The main function is to limit the energy the mirror can attain through accelerations caused by earthquakes or other failures.

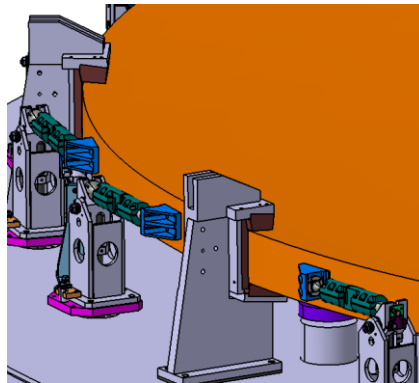

Figure 3.141. Earthquake safety clamps on the tertiary mirror.

3.6.5.2 POSITION ACTUATORS

The hexapod legs are based on the SKF SRSA7510 satellite roller screw actuators combined with an external linear encoder to provide absolute positioning accuracy. Cardanic joints connect the actuator onto the mirror cell and telescope structure.

The total stroke of each actuator is 320 mm allowing for up to 250 mm of actual motion in the direction towards the secondary mirror of which about 200 mm are allocated for focus change, ± 20 mm for control and the remainder for telescope mirror prescription and integration errors. Note that these latter errors are compensated by shimming during the integration and pre-alignment of the telescope optics. The required actuator resolution of 5 μm is provided by an externally mounted Heidenhain LIDA encoder.

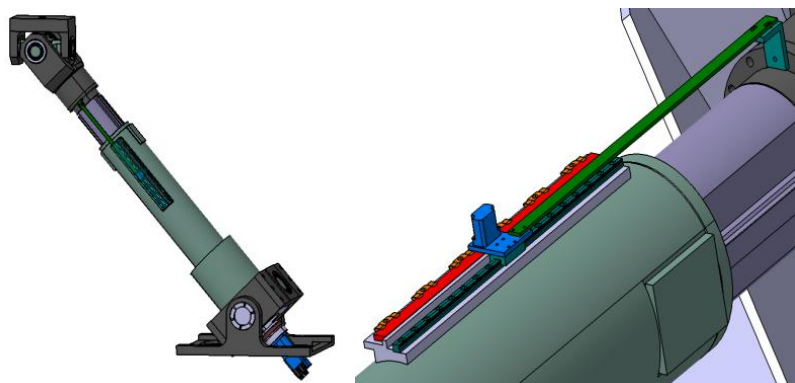

Figure 3.142. The M3 cell position actuator with cardanic joints and the encoder mounting.

3.6.6 PERFORMANCE OF THE MIRROR ON THE SUPPORT

The optical performance of the mirror has been simulated using finite element modelling. Assuming the correction of the first 13 elastic modes the residuals are 15 nm rms of wavefront error. The mirror support requires an active control of the shape actuator forces (based on look-up tables and wavefront sensor signals) as, in passive mode, the differential surface deformation between zenith and 70 degrees from zenith is several micrometres. From the experience gained during secondary unit studies, that gravity distortion can certainly be limited to about 5 μm peak-to-valley, so about 1 μm rms.

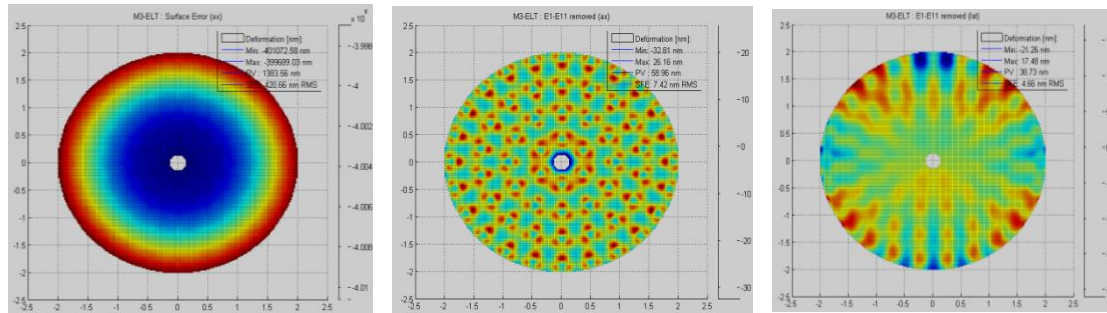

Figure 3.143. Gravity deformation of the tertiary mirror and deformation of the tertiary mirror after removal of the first 11 elastic mode terms and lateral support residuals.

Similarly, the analysis of the lateral supports provides low residuals of just under 10 nm wavefront error.

The tolerances on the lateral and axial supports have been analysed and positioning errors of 1 mm produce surface errors of order a few nanometres after removal of the low order terms.

3.6.7 CONTROL ANALYSIS

The tertiary mirror unit is similar in requirements and solutions to the secondary mirror unit. Two control systems, a positioning and a mirror shape system, are used.

For the positioning system, accuracies of 0.01 mm for the translation in the x , y and z directions and 0.3 arcseconds for a rotation around the x - and y -axes are required. The shape control delivers an accuracy of 10 nm surface error rms.

In contrast to the selected secondary mirror unit concept, the actuators in the tertiary mirror are controlled in force not only for shape control, but also in order to generate the support forces. The shape force is actively controlled for each individual actuator using a co-located load cell and proportional piezo-driven pneumatic valves used in on/off mode with a fixed opening and activation threshold.

The M3 control system architecture is based on an industrial PC and a Controller Area Network (CAN) fieldbus system. More detail of the baseline implementation can be found in the control section.

3.6.8 INTEGRATION

An integration stand is included in the supply of the tertiary mirror unit.

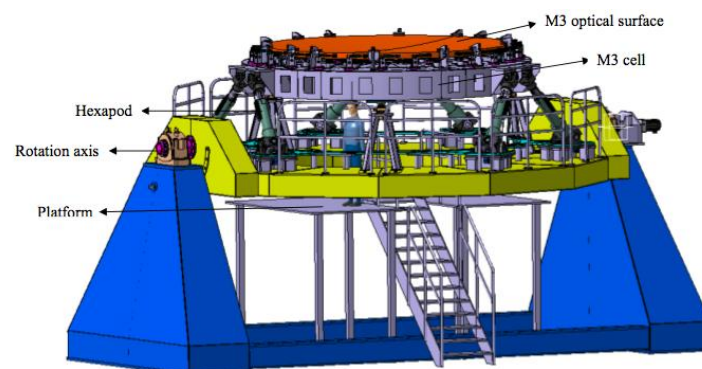

Figure 3.144. M3 cell integration stand.

The integration stand allows the assembly of the complete structure, mapping and calibrating of the unit deformation with gravity, and dismounting of the mirror for coating.

3.6.9 CHALLENGES

3.6.9.1 MANUFACTURING

The manufacturing challenge is likely to be one of availability of testing facilities for the mirror. At 4.0 metres, it is possible to have the mirror tested at a variety of locations, but this depends on the global demand for large optics. Possible commercial suppliers are LZOS, Sagem, AMOS and Brashear.

3.6.9.2 PERFORMANCE

The position actuators are quite challenging, although solutions of the necessary resolution and load-carrying capacity have been built for other projects.

3.6.10 ALTERNATE DESIGN/SUPPLY

The project has alternate offers for the supply of the tertiary mirror blank from Corning. An alternate design for the mirror cell has not been procured by the project.

3.7 QUATERNARY UNIT

The adaptive mirror is specified to deliver near-infrared diffraction-limited images with a Strehl ratio of over 70% in median atmospheric conditions (0.85-arcsecond seeing, t_0 of 2.5 ms). The dimensions of the adaptive mirror are dictated by the optical design, while the spacing of the actuators is limited by existing technologies. The combination of these two factors provides a mirror of approximately 2.5 metres in diameter with up to 5800 actuators (5200 actuators in the active optical area) each projecting to 50 cm on the primary mirror of the telescope.

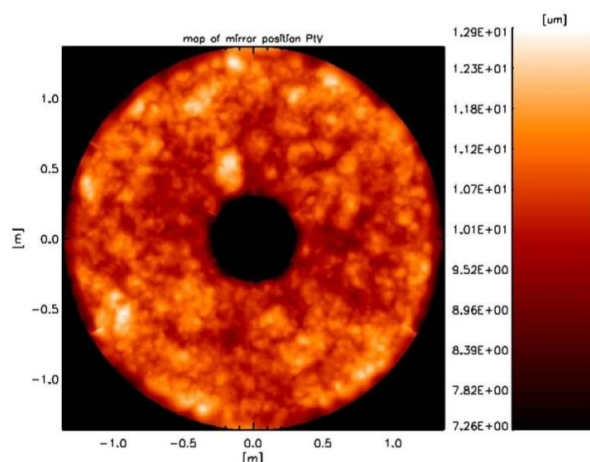

Figure 3.145. Mirror positions calculated for median seeing using 1000 uncorrelated wavefronts.

The baseline adaptive mirror is designed to have a spatial residual fitting error of 120 nm rms and a temporal error below 60 nm rms with a wavefront sensor sampling frequency of 1 kHz. In order to ensure that the mirror is not saturated in poor atmospheric conditions, the stroke requirements that would limit the mirror is specified to be sufficient for 2.5-arcsecond seeing.

In addition, the M4 unit will be capable of correcting residual tip-tilt (120 mas on-sky) arising from telescope wind-shake, but not fully compensated by M5, and residual telescope-accumulated low-order wavefront errors 5 μm .

The baseline for the quaternary is for a six-petal, 2 mm thin deformable mirror actuated with voice coils. The coarse positioning of the adaptive mirror unit, for the purposes of collimation, is performed with a hexapod unit while the rotation of the mirror for the switch between the two Nasmyth foci is performed on a rotating bearing making up the quaternary positioning system.

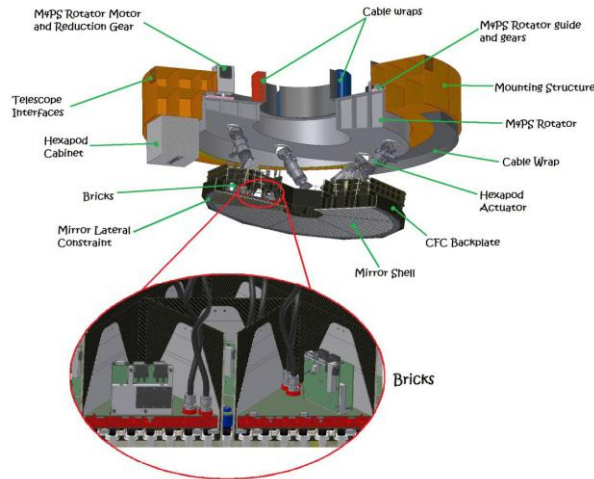

Figure 3.146. Quaternary unit overview.

The actuator pattern is triangular, giving a 31.5 mm spacing for a total of 5790 actuators with 5232 in the useful optical area. The actuators on the periphery compensate for the lateral restraints on the thin shell. Along the radial edges of segments the density of actuators is somewhat higher with a 28 mm spacing.

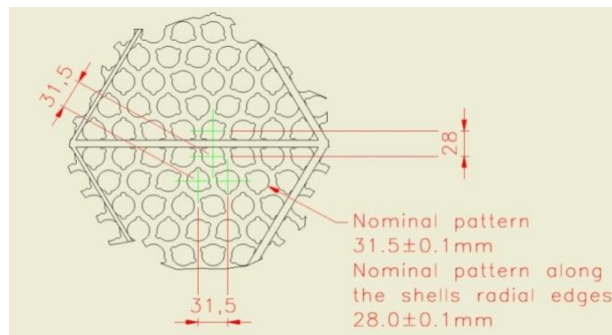

Figure 3.147. Actuator pattern.

The mirror is supported on a stiff reference body that is made either of carbon-fibre-composite material or silicon carbide, providing high stiffness, low weight and good dimensional stability.

The structural design of the reference body is layered with increasing dimensions of the basic units (triangles) as one moves away from the mirror. At the lowest level the triangles match with the actuator units (see below). The increased dimensions in the back make maintenance easier.

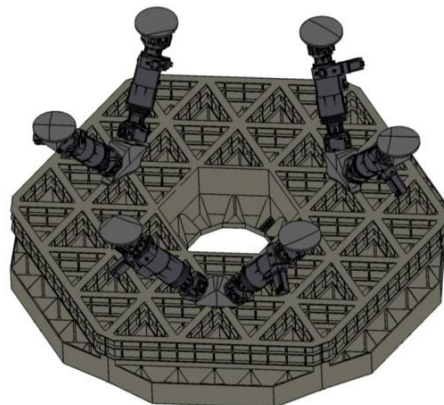

Figure 3.148. The reference body with hexapod legs.

The machining of the actuator inserts will be done either using CNC milling with special tooling or by water-jet cutting. The known problems of carbon-fibre absorption of moisture have been considered and the manufacturers consider this a known issue with well-engineered solutions.

A series of borosilicate inserts installed into the reference body front face will provide the capacitive sensor armature, providing the co-located feedback that allows the actuators to be controlled in position.

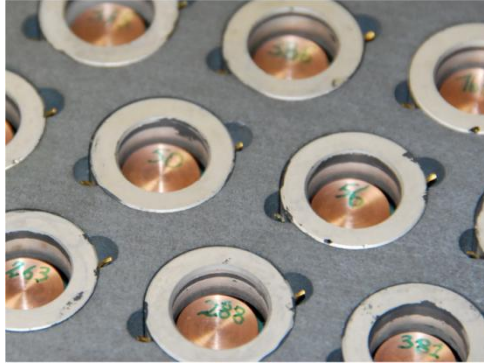

Figure 3.149. Borosilicate inserts in the prototype reference body.

Inside the lowest level of the reference body the “bricks” carrying the actuators and local drive electronics are inserted. These are line replaceable units.

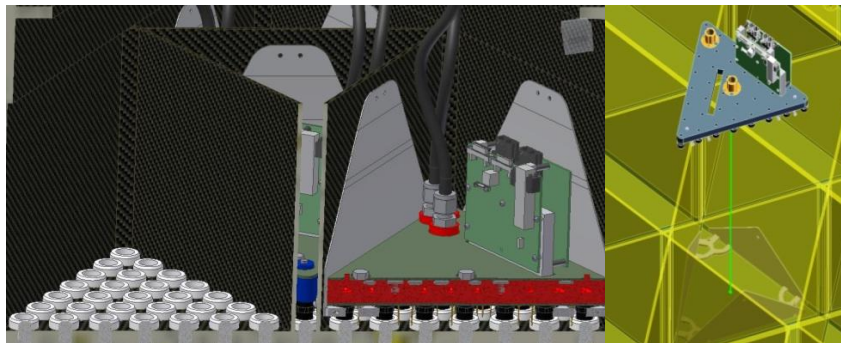

Figure 3.150. A brick interfacing with the borosilicate inserts and being inserted into the structure.

The brick is an aluminium plate with a cooling channel machined into it. Both 33% water-glycol mixture and a liquid gas can be run into the brick to cool it actively. In particular, the novel idea of using liquefied gas as coolant has been successfully tested on a brick breadboard and might be adopted as baseline during construction. The benefit of such an approach is to make the M4 unit fail-safe against possible leakages, which for the liquid gas case would evaporate.

The actuators interface to the lower side of the brick, while the electronic boards implementing digital control, supply and communication for the actuators are mounted on both sides of the brick and on an additional vertical fin. All data, power and cooling interfaces are placed on the top side of the brick for easy accessibility. Lateral plates are used to install the brick into the reference body. The installation and alignment of the bricks is optimised to allow easy replacement for maintenance purposes. The lateral plates remain in the reference body so that when bricks are exchanged, no further alignment is necessary.

With the bricks inserted, the back structure is closed with caps that avoid convective heat dissipation that could pollute the telescope beam.

The voice coil actuators in the baseline design are the same as used in previous deformable mirror systems by ADS/Microgate, and in particular those for the ESO VLT deformable secondary mirror that is being integrated at the time of writing.

The deformable mirror is a flat 1.95 mm thin shell. In the baseline solution, the mirror is segmented into six 60-degree petals with an inner diameter of about 600 mm and a diameter of about 2400 mm at the outer rim (hence a single petal is about 900 mm in its longest dimension). The material selected is Zerodur.

Lateral support is provided to the glass petals from the external ring only, using flexures that are glued to the edge of the mirror.

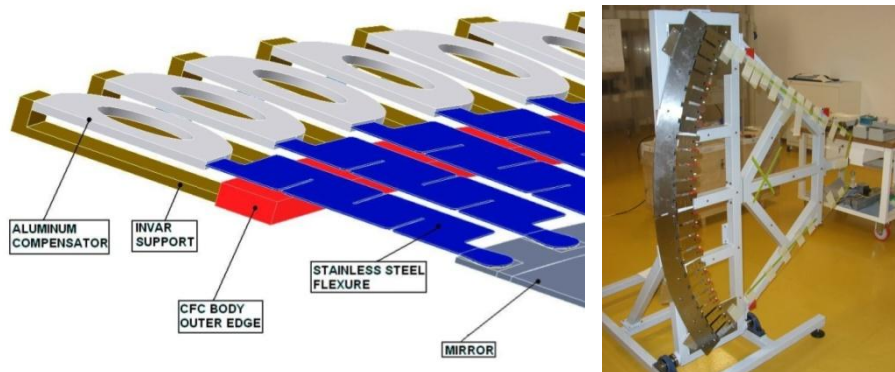

Figure 3.151. The lateral restraint for the thin shell and scale-one breadboard (using plate glass rather than Zerodur).

3.7.1 POSITIONING UNIT

The entire quaternary mirror unit needs to rotate 180 degrees to allow the telescope to access either Nasmyth focus. This is achieved using a rotating bearing based on guides. Normally closed (fail-safe) pneumatic brakes are built into the system. During observations the rotation mechanism is parked and consumes no power.



Figure 3.152. M4 mounting structure and positioning system for the Dark Energy CAMera.

For alignment and for stroke management (tip-tilt), the unit is mounted on a hexapod. The stroke is ± 25 mm with an incremental motion of 250 nm. The nominal load, including safety margin, is 1.5 tonnes per leg while in the case of an earthquake the total load increases to 3 tonnes. The unit is, to all intents and purposes, identical to the unit produced at ADS for the Dark Energy CAMera at the Cerro Tololo Inter-american Observatory (CTIO).

3.7.2 CONTROL SYSTEM

The control system for the M4 unit includes all the necessary components for the control of the actuators, taking into account the safety of the system and maintaining phasing of the segments. It does not include the real-time computer that takes the information from the wavefront sensors and converts it into an aberration command and subsequently to a position command to the M4.

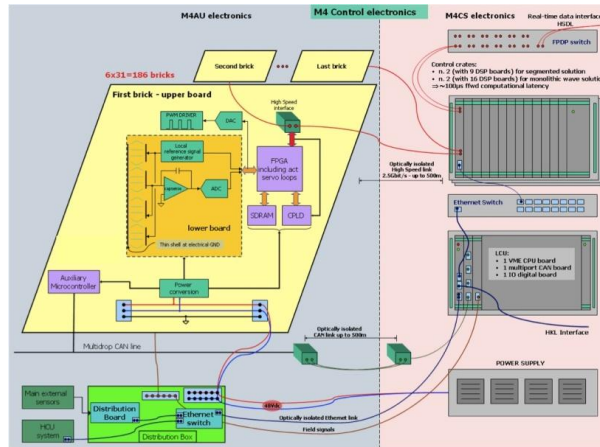

Figure 3.153. Control layout for the M4 unit.

Almost all field electronics are on-board the bricks with minimal connections. In addition to the cooling, only the power and data link are required by the bricks. The data acquisition and processing of the capacitive sensors and the voice coil current drives are all on-board the bricks. The control of the actuators is based on Field-Programmable Gate Arrays (FPGAs) that are on-board the bricks. Besides the high-speed data link, an additional field bus connects the individual bricks for safety and maintenance.

The computationally heavy activities, such as feed-forward command computation, can be located at a distance of 500 metres from the unit thereby reducing the heat load on the telescope.

3.7.3 THIN SHELL MANUFACTURING

The baseline design of the actuation stage is compatible both with a monolithic thin shell and a segmented one. The project baseline for the mirror is the segmented thin shell as it provides for a realistic policy on spares and has reduced maintenance and operation costs.

The thin shells are made in a four-stage process. A flat optical surface is polished into a thick piece of Zerodur. The piece is flipped and placed on a blocking body. It is then relatively rapidly machined down to just under 3 mm thickness. The final millimetre is removed by grinding and lapping, leaving a polished finish on the back side of the glass.

The thin sheet is then cut to petal shape using a water jet or conventional milling. The development of the cutting process, although certainly not without risk, has benefitted immensely from the prototyping activities.

Part of the demonstration activity undertaken at phase B has been the production, using borofloat glass, of a scale-one 2.7-metre diameter 1.9 mm thin sheet. A combined handling tool and blocking body that can be used on the polishing machines has been designed and built for this piece.

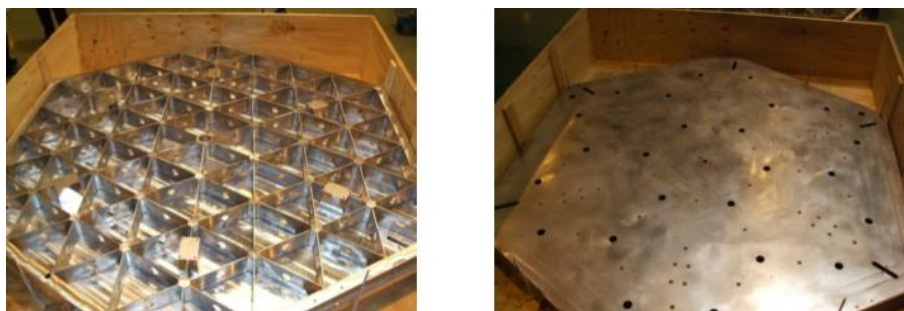

Figure 3.154. Rear and front side of the blocking body for the 2.7-metre 2 mm thin shell prototype.



Figure 3.155. The 2.7-metre 2 mm thin shell on the blocking body and in the thinning process.

3.7.4 PERFORMANCE

The specification for the quaternary unit has been established to enable diffraction-limited operations using this mirror alone. The fitting error has been used by the contractor to evaluate the actuator density, stroke and dynamic performance.

A prototype unit was constructed during phase B and a series of optical and electrical tests have been performed. The prototype is made of two Zerodur segments with eight bricks behind each segment supported on a SiC reference structure.

A stitching interferometer based on a 10 cm beam was used for the high spatial frequencies. A full aperture test at variable spatial frequencies (inclined test setup) was used to provide low spatial frequency information and a piston sensing unit was used to overcome the $\pi/2$ ambiguity at the segment edges.

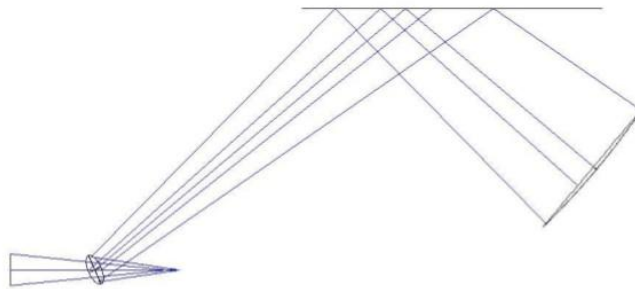

Figure 3.156. Prototype optical layout of the full aperture test.

The project considered a demonstration of the ability to phase the segments to be a critical component of the demonstration prototype activities.

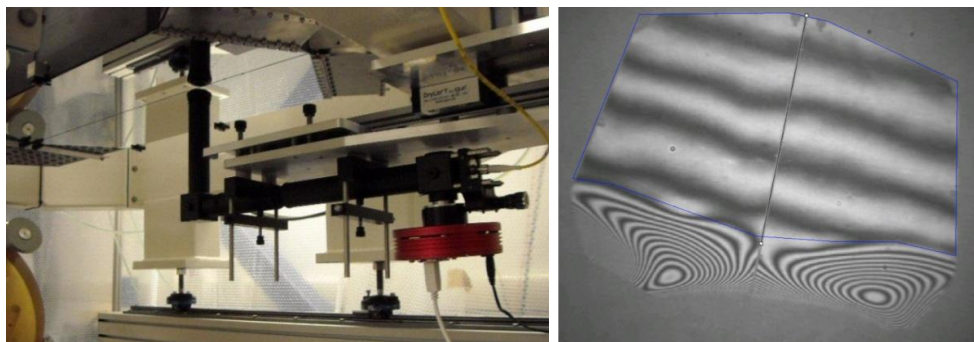

Figure 3.157. Prototype and demonstration of the phasing of thin sheets. The piston sensing unit in front of the demonstration prototype (left) and fringes across two segments at the demonstration prototype (right). The lower regions are deformed due to the supporting structure and are not part of the useful area.

Much attention was also placed on the passive stability of the flattening command to the mirror. The quaternary needs to be able to achieve a flat surface for passive operation or for alignment of other mirrors.

The electromechanical performance of the prototype has been thoroughly evaluated by measuring the modal and local response time and performing simulated turbulence compensation in order to measure the dynamic residual error. Most results were within the specifications. A dynamic following error test gave evidence of a design flaw in the electronics and control software. The design has since been improved to overcome that limitation.

The positioning hexapod has been extensively modelled and, thanks to the production of an almost identical unit, prototyped.

The adaptive unit control system provides shape and tip-tilt control of the thin shell mirror using decentralised position control for all the actuators with their local capacitive sensors. The unit has been studied in great detail using numerical analyses and simulations. The structural models were derived from finite element modelling data. Actuator and sensor characteristics were derived from electronic models and further developed by breadboard tests. Additionally, the fluid dynamic interaction caused by the air layer between thin shell and reference structure and local deformations of the capacitive sensors were taken into account in the control model and validated on the Large Binocular Telescope (LBT) 672-mirror unit that has been successfully deployed. The match between model-predicted and measured dynamic responses is very good and allows very reliable performance predictions. The baseline design reaches a local closed loop position loop bandwidth of almost 700 Hz.

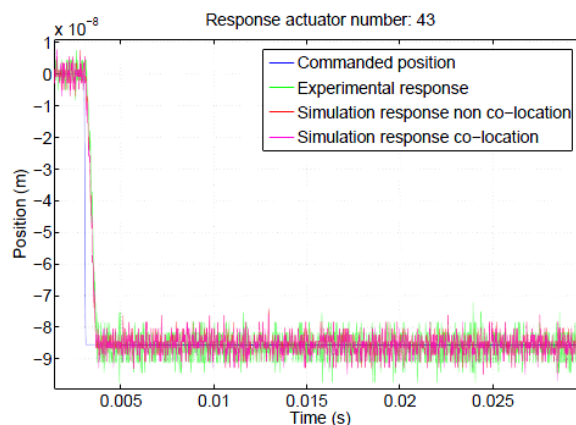

Figure 3.158. Step response of a single actuator — simulation and measurement.

The decentralised control scheme proposed by Microgate foresees damping and coarse position control at actuator level. In order to achieve the demanded dynamic performance on all controlled modes, an additional feed-forward command is necessary, generated at the level of the entire quaternary mirror. The stringent derived requirements in terms of sampling, propagation and computation delays, and signal-to-noise ratio have strongly influenced the final control hardware architecture. Emphasis has been placed on local analogue to digital conversion, decentralised control and digital communication using multimode fibres. Last but not least, the dimensional and power dissipation constraints, as well as the simplification of the interfaces, had a strong impact on the hardware design choices. Due to these specific design constraints the M4 unit will contain a considerable amount of custom electronics.

3.8 TIP-TILT / FIELD-STABILISATION UNIT

The M5 mirror is used to correct for low bandwidth (a few Hz) tip-tilt errors arising from the effects of the wind on the telescope and larger amplitude errors from the atmosphere. Being neither at a pupil nor at an image plane the mirror is required to maintain its flat shape to high precision to limit any field effects. The mirror dimensions are 2.2 metres by 2.7 metres and it is required to have an areal density of less than 90 kgm⁻² and a first eigenfrequency of over 250 Hz.

The wavefront error of the rigid mirror on scales greater than 40 mm has to be better than 0.5 μm peak-to-valley and less than 15 nm rms over smaller patches. During observation, the additional mirror deformation shall not exceed 100 nm rms for scales larger than 40 mm and 15 nm rms for smaller scales.

The tip-tilt performance of the unit has been specified to correct 1-arcsecond rms wind-shake from the telescope leaving a residual of 70 mas over the entire frequency range and 4 mas at frequencies above 9 Hz.

The M5 unit has been designed and prototyped on the basis of a three-point actuated support of the mirror without a counterweight system. The mirror is restrained laterally using a central membrane. The entire unit is inclined at 52.75 degrees and mounted on a rotating stage provided by the telescope main structure.

3.8.1 THE M5 MIRROR

The baseline is a closed-back ULE mirror with a lightweight square core. The design performance of this mirror is exceptional, with an aerial density below 70 kgm^{-2} and a first eigenfrequency at above 290 Hz. The lightweight core is made using abrasive water-jet technology with 2.5 mm thin ribs. The back face sheet is spherical. The cores and face sheets are joined using a low temperature fusion process.

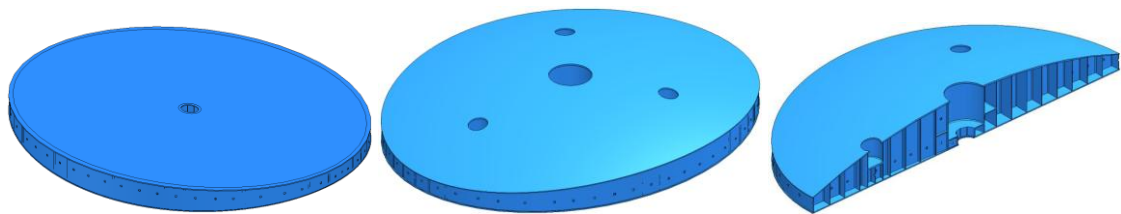

Figure 3.159. ULE M5 mirror design with close-back lightweight structure (left), square core cell (centre) and spherical back surface with dimensions (right): 2180 mm \times 2720 mm, 40 kg and a first eigenfrequency of 296 Hz.

ITT and Corning have collaborated in the past to manufacture similar mirrors using the same basic tools and processes.

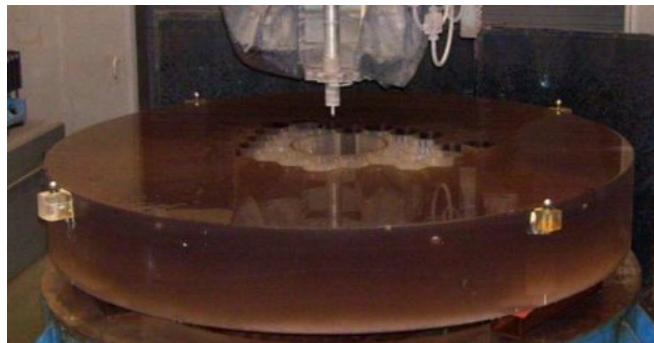

Figure 3.160. A 2-metre diameter 3 mm thick mirror made for another programme, under abrasive water-jet cutting. The final mirror had significantly better performance than our specifications.

The mirror will be optically polished at ITT using large tools and will be finished if necessary using an existing ion-beam machine. Some process development has been undertaken already to water jet deeper cores than previously achieved.

The mirror is constrained laterally with a membrane at its centre and axially at the three interfaces to the actuators. These locations are strengthened by comparison to the other struts in the core. The gravity deformations are to be compensated during polishing by ion-beam polishing into the surface the necessary correction.

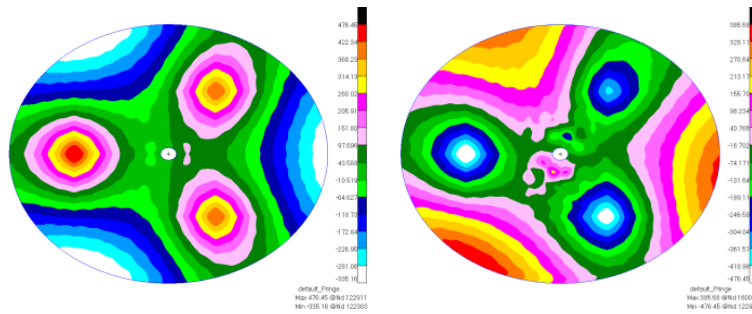

Figure 3.161. Gravity distortion. The wavefront error on M5 is 260 nm rms at zenith and 270 nm rms at 70 degrees orientation.

The behaviour of the mirror under the routine accelerations applied in the tip-tilt operations has been analysed and the contribution to the wavefront error is small (< 20 nm).

3.8.2 ELECTROMECHANICAL UNIT

The support unit is based on a fixed-frame main structure that carries the base frame upon which the actuators and the central restraint are located.

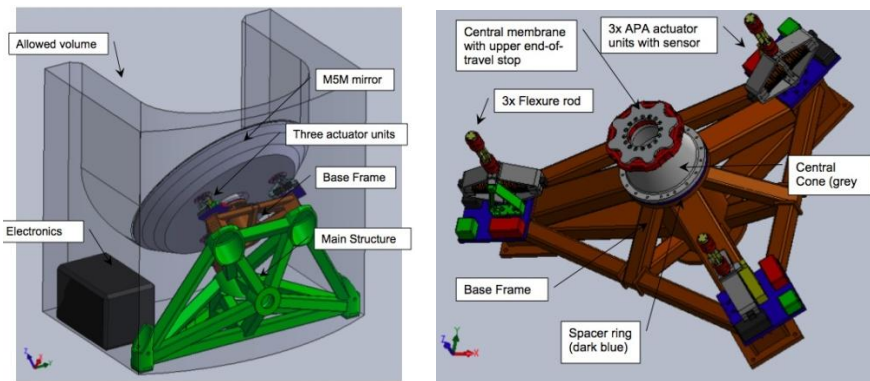

Figure 3.162. The M5 unit and the base frame, actuators and central restraint.

The design, by NTE/SENER/CSEM/Sagem, included a SiC mirror solution and therefore the interfaces make reference to that material. As can be noted above, this SiC mirror does not form the baseline solution for the project and the interfaces will in any case need to be optimised during the production phase^{††}. An integrated model using the NTE design and the ULE mirror has been built at ESO, and the performance of the whole unit matches the requirements well.

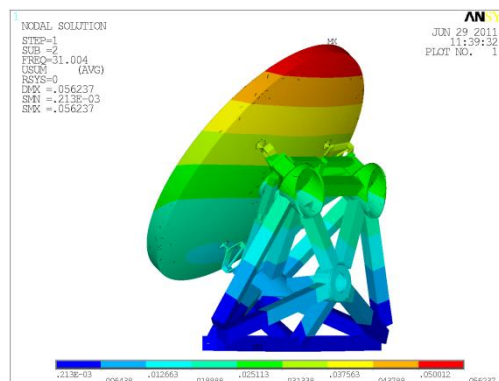

Figure 3.163. Integrated model with M5 ULE mirror.

^{††} Since the mirror is the most difficult component, the natural conclusion is that the interface is best driven predominantly by the mirror constraints.

The 365 mm diameter central membrane restraining the mirror laterally is very similar in concept to the primary mirror restraints. The membrane permits travel in the direction of the actuation while providing stiffness in the orthogonal direction.

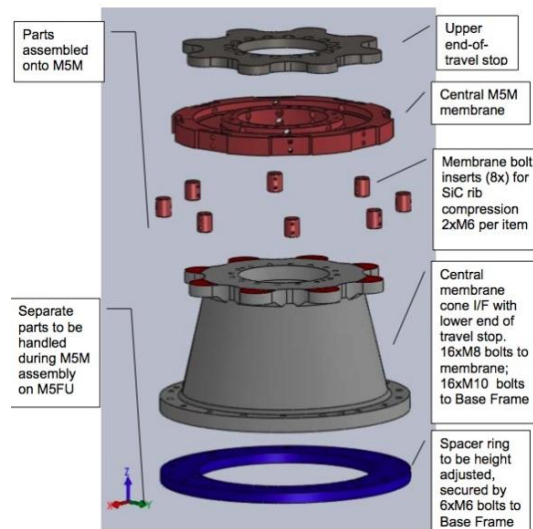

Figure 3.164. Components of the central restraint.

The membrane together with end stops are introduced into the mirror. The conical interface is bolted into the membrane. The entire unit can be shimmed with respect to the fixed frame. The end stop restricts the maximum displacement of the central membrane to ± 75 mm.

The actuators connect to the mirror via flexures that ensure axial stiffness while not introducing lateral forces.

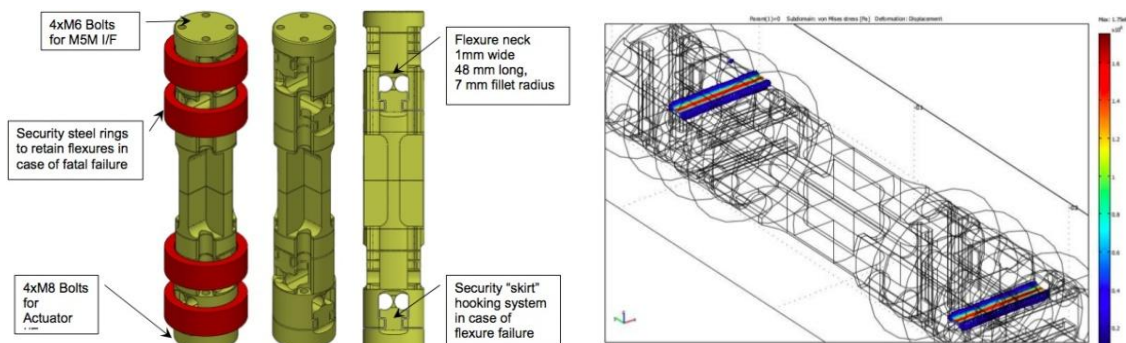

Figure 3.165. Axial flexures connecting the mirror interface to the actuators and the stress calculation for flexures.

The actuator is based on a CEDRAT APA design, custom built for the E-ELT. A preloaded elliptical steel ring is forced open by the action of a piezo stack running along the major axis. The actuation direction is along the minor axis. In the relaxed state, the actuator is at its maximum extent and expanding the piezo compresses the actuator. At zero volts, the actuator has a nominal height of 240 mm while at 1 kV the piezo lengthens by 270 μm and the actuator shortens by 2.25 times more or 600 μm .

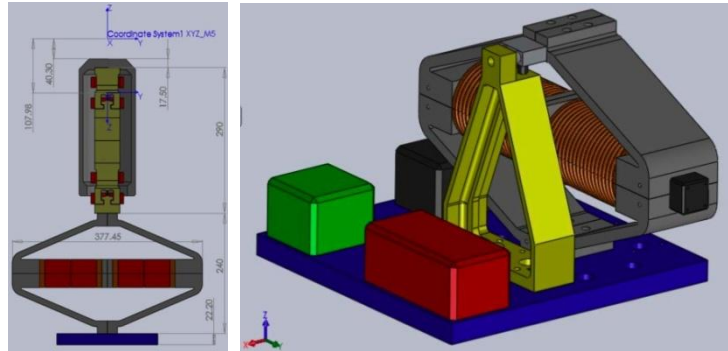

Figure 3.166. Actuator and flexure dimensions and the actuator line replaceable unit.

The intrinsic stiffness of the actuator is high. The actuator is a substantial device with a footprint of almost 400 mm and is a line replaceable unit together with its calibration device and drive electronics. A position sensor is used to provide absolute calibration and feedback to the actuator. It is mounted on the same flange as the actuator.

The position sensor selected is an eddy current device from micro-Epsilon that provides a 15 nm resolution over a 1 mm range. The actuator provides three interfaces for accelerometers to be mounted at the ends of the piezo stack and at the vertex close to the flexure. In controlling the actuator it is therefore possible to have both position and velocity information.

The total stroke of each actuator is 0.75 mm. The atmospheric contribution to the stroke is very small. The wind rejection dynamic stroke is a fourth of the total stroke. The remaining stroke is used for fine alignment and to compensate for gravity deformations.

3.8.2.1 PERFORMANCE

A scale-one prototype unit has been constructed during the phase B by NTE/SENER, the prime contractor. CSEM developed the all-mechanical parts including the dummy mirror design made of a Newport optical table. NTE developed the test stand and the control hardware.



Figure 3.167. Prototype scale-one unit with dummy mirror and one of three actuators mounted in prototype unit.

The scale-one prototype has been manufactured including the inclined support and the fixed frame. All interfaces to the mirror have been reproduced on the dummy aluminium mirror that has the same mass as the real mirror. The eigenfrequencies of the dummy mirror are lower than the real mirror, but this does not affect the performance of the system.

The control of the M5 mirror actuators is based on a series of nested loops. An inner speed loop fed by signals coming from the accelerometers damps the resonances of the actuator, providing stability for the outer position loop that is fed by the position sensors. The set point for the actuators is provided to the system by the “ESO” loop fed by the wavefront sensor.

The co-location of the speed measurement (using accelerometers) with the actuator provides damping in a large frequency range and ensures that evolution of the actuator properties due to aging or maintenance activities will not create inadvertent instabilities.

3.8.3 ALTERNATES

The project has not developed an alternate design for the M5 electromechanical unit. However, the solution developed is not proprietary and can be sourced from alternate suppliers. Moreover, the project has a number of options available for the mirror, including silicon carbide from Boostec (F) and light-weighted Zerodur from Schott (G). In both of these cases the project would need to find a polisher.

3.9 PRE-FOCAL STATIONS

In common with the VLT, NTT and other ESO telescopes, an adapter is envisaged to hold guide probes in fixed positions with respect to the telescope focal plane and the sky. For the E-ELT, two concentric adapters, one for lasers and one for natural guide stars, are located ahead of the natural focus of the telescope. This provides volume ahead of the focus to divert the full field of the telescope sideways to folded ports.

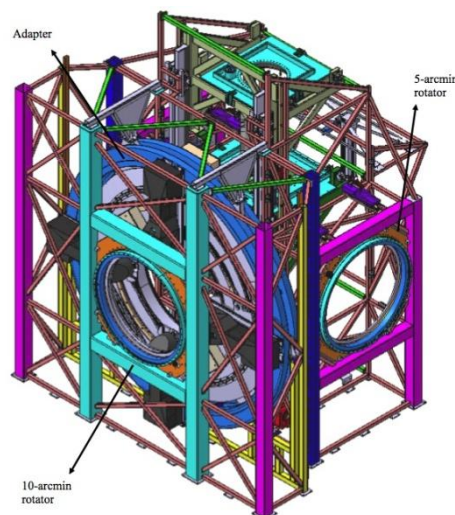

Figure 3.168. The complete pre-focal station.

A large steel structure is mounted on the Nasmyth platform and carries the natural and laser guide probe adapters and an instrument rotator at each of the three ports. In the centre of the structure, an elevator is used to position the M6 mirror that is required for the selection of the focus. In the case of the coudé focus, an arm is located ahead of the structure that inserts the coudé pick-off mirror into the beam.

In the natural guide star adapter, three arms are used in routine operation and a fourth is allocated to a phasing sensor. The laser adapter has four arms oriented permanently in a cross configuration, but with variable radii.

Each natural guide star probe provides a 20-arcsecond field of view for acquisition and a 3-arcsecond field stop for the selection of the star whose light will be sent to the wavefront sensor. The natural guide star probes can track differentially across the field of view correcting for refraction and following moving targets.

3.9.1 PRE-FOCAL STATION STRUCTURE

The common framework structure provides the basis for mounting the two lateral rotators, the straight-through rotator and the adapter that carries the guide probes ahead of it.

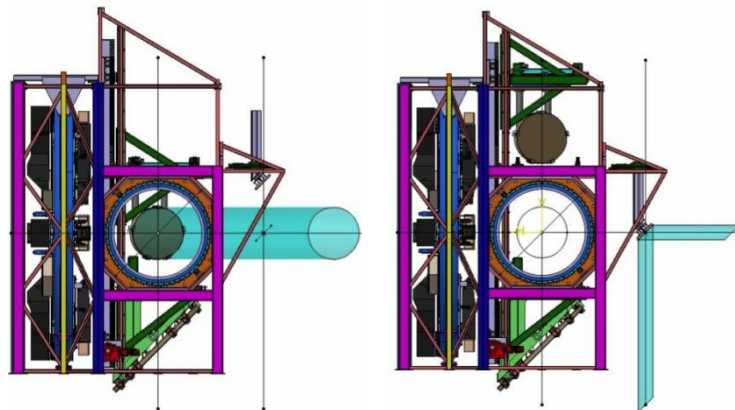

Figure 3.169. M6N in position, directing 5 arcminutes of the beam out of the plane of the paper towards the reader and M6C in position diverting the central 20 arcseconds to the coudé train.

In the mid-section an elevator locates the folding mirror (M6). The pick-off mirror for the coudé (M6C) is located well ahead of the beams.

3.9.2 GUIDE PROBES

The combination of rotation, necessary in any case to follow the field, and radial motion allows the guide probes to be positioned in any location in the field of view. Two bearings mounted either side of a stiff structure carry the guide probes. In the ESO nomenclature the entire unit is called an adapter.

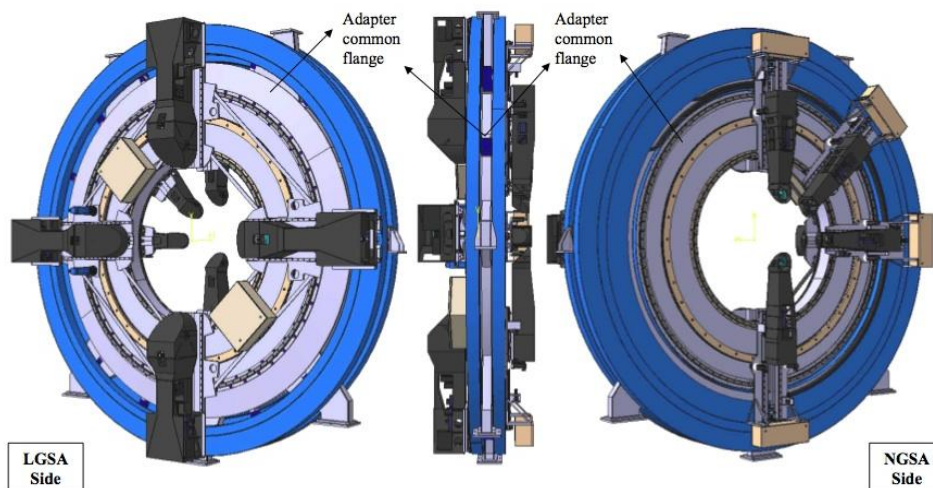

Figure 3.170. Laser and natural guide probe adapters.

3.9.2.1 NATURAL GUIDE STAR

The Natural Guide Star (NGS) guide probes access the entire field of view of the telescope and provides both a direct imaging capability with a limited field of view (20 arcseconds) and a spatially-filtered aperture for the Shack–Hartmann sensors. This design follows very closely the concept that has been extremely successful at the VLT. The guide probe is made of aluminium–beryllium alloy, again similar to the VLT, providing the same stiffness as steel at a quarter of the weight.

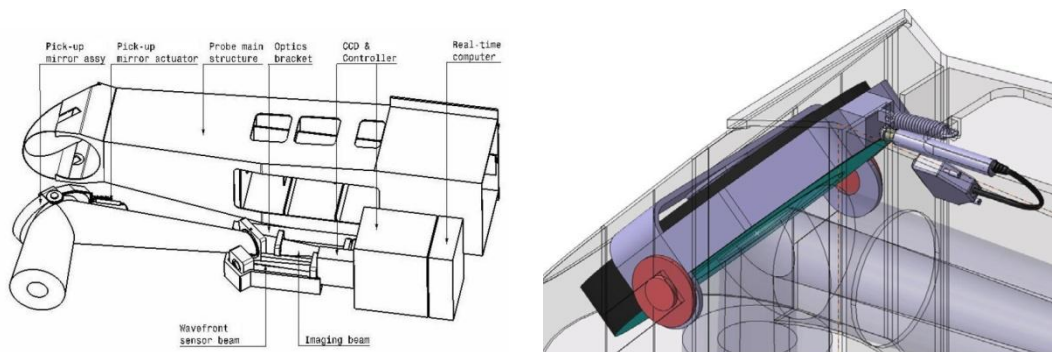

Figure 3.171. Main components of the NGS probe and tilting the pick-off mirror.

The pick-off mirror is actuated with respect to its normal 45 degrees inclination in order to follow the field curvature.

The mechanical dimensions of the probes are significant. The length is just under 1900 mm and the pick-off mirror is 230 mm in diameter. The mass of the probe is approximately 130 kg.

The probe is mounted on a stiff plate that is driven in and out of the field of view of the telescope using a translation stage based on a simple track and screw drive system with an accurate encoder.

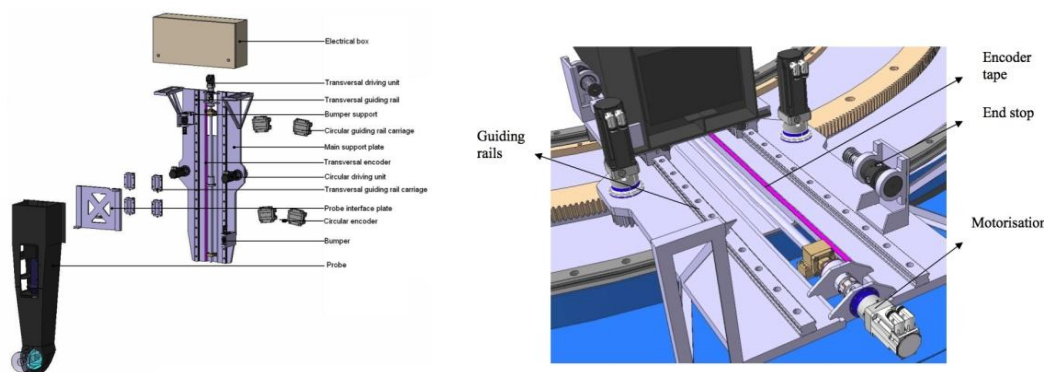

Figure 3.172. The components of the translation stage.

Including the translation stage and electronics, the total mass of each natural guide star probe is approximately 540 kg.

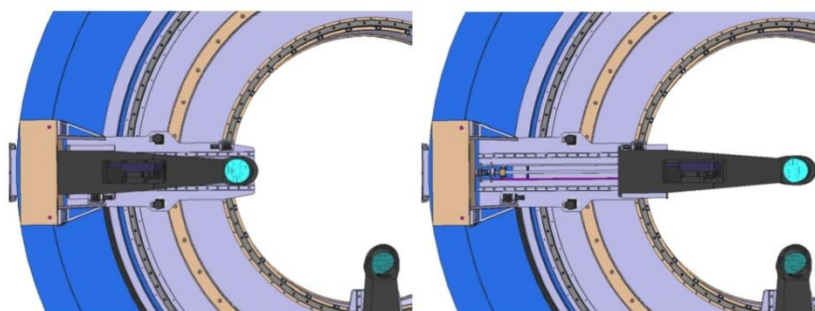

Figure 3.173. The guide probe retracted and extended.

The translation stage rides on parallel rails and is driven by a low torque motor (1 Nm) through a gear-box on a ball screw. The positioning uncertainty of this system based on commercially available components is calculated to be less than 7 μm . A 5 μm resolution Renishaw encoder is used to establish absolute positioning.

The rotation of the probe is made on two THK concentric rails. The probe supporting structure rides on two sets of two ball slides. A high degree of concentricity (within the differential run-out) is required to minimise the friction of the bearings. In collaboration with the bearing supplier the solution adopted is to use eccentric cams to locate the outer rail once the inner one has been installed.

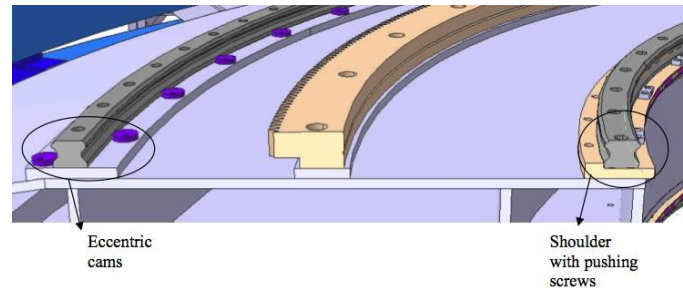

Figure 3.174. The concentric rails for the adapter and the rack for the drive units.

The rotational motion is achieved using two motors, preloaded electronically, and driving against the 4260 mm diameter crown gear. The rotational stage is encoded using a Heidenhain tape encoder. One reading head is considered per probe.

Each probe requires power, network and cooling, necessitating a cable-wrap system to be built into the adapter mechanics. The electrical cabinet that drives the probe components is mounted on the probe thereby limiting not only the numbers of cables going through the wraps but also the possible electro-magnetic noise sources on data and control signals.

A cascading cable wrap system is used. An external 5-metre diameter cable wrap feeds three smaller interior ones.

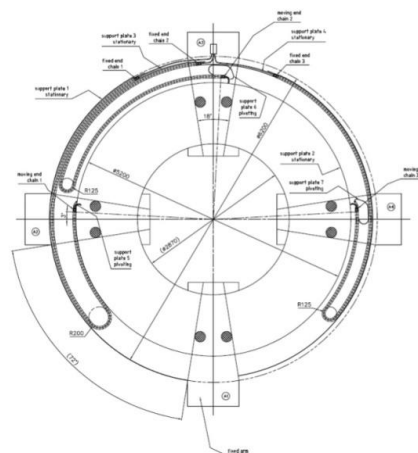

Figure 3.175. The natural guide star cable wrap system.

3.9.2.2 LASER GUIDE STAR PROBES

The laser guide probes are configured in a cross pattern without an option for differential rotational motions, although they can move differentially in the transverse direction.

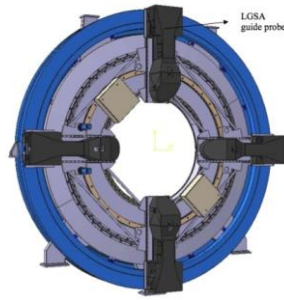

Figure 3.176. The laser guide star adapter.

Each probe is a substantial optical element, 2040 mm long, hosting a 574 mm diameter pick-off mirror.

Similarly to the natural guide star the pick-off mirror, tilt can be adjusted. Additionally, the optical train provides two folding mirrors that are located at a pupil and image plane to permit fine adjustments that ensure the residual differential motions of the laser beam relative to the telescope can be compensated^{§§}.

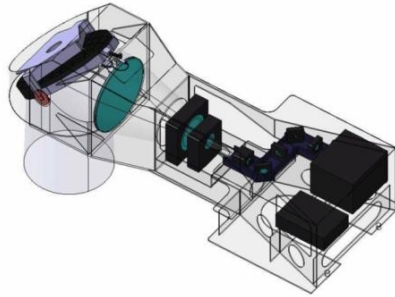

Figure 3.177. The laser guide probe.

Volume provision is made for the fast readout electronics of the wavefront sensors and any near-detector computations that may be necessary. The mass of each laser guide probe arm is 1000 kg.

In terms of mounting and driving, the solutions are almost identical for the laser guide probes as for the natural guide systems, but with some simplifications due to the fixed geometry.

3.9.3 INSTRUMENT ROTATORS

Each pre-focal station provides three instrument-mounting locations and provision is made at the through-focus for an instrument de-rotator, independent of the guide probes. The straight-through focus provides for the full 10-arcminute field of view.

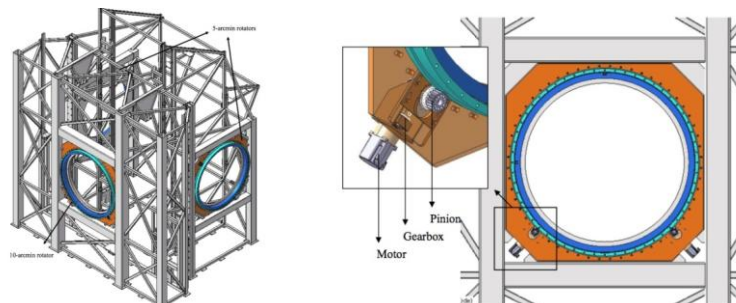

Figure 3.178. The three instrument rotators and the location of the rotator drives.

^{§§} The bulk of the differential tip-tilt is handled by the laser launch system.

Two preloaded motors drive the rotator and a Heidenhain tape encoder is used for absolute referencing. The brakes are built into the motors and no independent braking system is envisaged.

3.9.4 THE ELEVATOR

Locating the folding mirror (feeding the lateral ports) in and out of the beam is achieved by an elevator located in the centre of the pre-focal station framework structure.

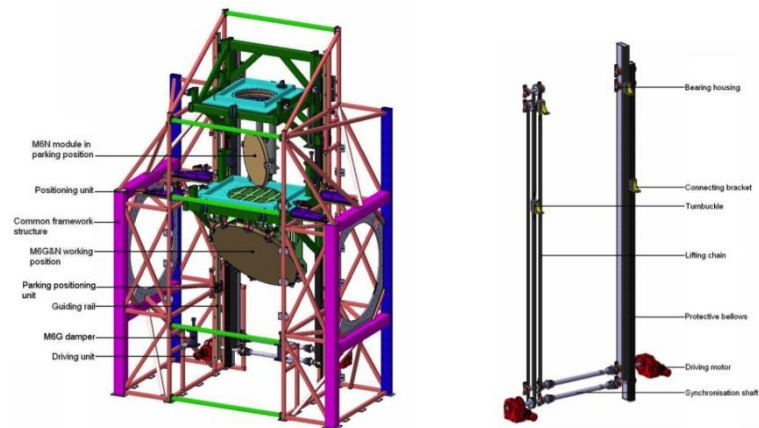

Figure 3.179. The elevator, the M6N units and elevator drive system (M6G mirror shown here no longer exists).

The movement of the mirror and its precise positioning have been decoupled as actions, thereby avoiding the need for a long and precise travel. The driving system for the mirror is based on guiding rails, mounted onto the framework structure, and a lifting chain system. The mirror rotates to provide access to the two folded Nasmyth foci. The M6N mirror is mounted on a rotation stage to select the side focus.

The vignetting of the beam outside the central five arcminutes that are diverted has to be kept to a minimum to allow the straight-through adapters to retain the control of the telescope. The vignetting is minimised by “hanging” the mirror on two pillars that are mounted on a motorised rotating plate.



Figure 3.180. M6N unit and M6C in and out of position.

The small coudé mirror is mounted on a 1600 mm long pillar that is driven in and out of position using a rack and pinion system. The unit is locked into position using a preloaded clamp.

3.9.5 OPTICS SUPPORT

3.9.5.1 M6N

The M6N mirror is an elliptical flat, 2 metres by 1.5 metres in size and 110 mm thick.

The design has assumed the material properties of Zerodur and the mirror is not light-weighted and, although this would be an option to reduce the mass of the overall system, it is expensive. A central membrane is located in a deep central hole to provide the lateral support of the mirror while three axial flexures define the mirror position in the direction of the beam.

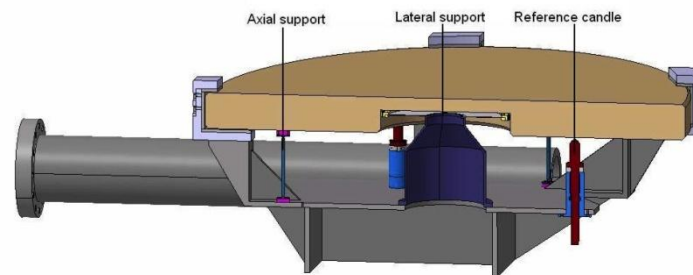

Figure 3.181. M6N mirror support.

Lateral clamps are used to support the mirror and minimise the loads in the case of an earthquake.

3.9.5.2 M6C

The coudé mirror is, by comparison, small and can easily be supported using the same system as for the M6N. In this case the lateral restraints are unnecessary.

3.9.5.3 LASER GUIDE PROBE KICK-OFF MIRROR

Although the unit has been dimensioned for a solid elliptical mirror, 780 mm by 560 mm and 100 mm thick, made of Zerodur, given the dimensions and location of this mirror it is considered that a silicon carbide option is a better match.

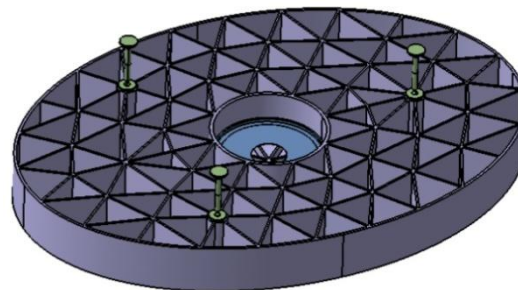

Figure 3.182. Concept for a SiC pick-off mirror for the laser guide probe.

A SiC mirror would weigh 15 kg, saving almost 70 kg relative to the Zerodur baseline.

3.9.6 CHALLENGES

3.9.6.1 MANUFACTURING

The pre-focal station is a very large structure and is critical to the telescope operations. The bulk of the steel structure is not particularly challenging and can be pre-erected in Europe for testing. The total weight of the unit is high and this places a significant constraint on the Nasmyth platforms.

Polishing the M6N will require a dedicated test setup, is likely to be time consuming and is known to be expensive. Depending on first light instrumentation requirements it is considered that the M6N ought to be delayed so as not to become a schedule driver for the overall telescope (first light and instrument at straight-through focus).

3.9.6.2 PERFORMANCE

Keeping the mechanisms of the guide probes cool is considered a significant challenge. Any heat generated so close to the focal plane is likely to pose significant problems to the rest of the optical train. The related risk is that the detector systems used in the guide probes will have data rates that pose challenges to the cabling and the data communication paths. While a solution of embedding the conversion of the wavefront sensor images directly into slopes at the detector head is plausible, the additional computing power is likely to challenge the cooling requirements.

The in-telescope verification of the guide probe performance, independently of the rest of the system, is likely to be challenging. From a commissioning point of view, the adapter is the device against which the telescope will be made to work and therefore the first instruments are likely to be validators. This is considered as part of the commissioning of the telescope, as was the case for the VLT.

3.10 LASER GUIDE STARS

3.10.1 INTRODUCTION

A laser beacon is used to create an artificial star in the mesosphere at an altitude of approximately 90 km by resonant excitation of sodium atoms in the atmosphere using a laser source. The sodium D2 transition corresponds to a yellow laser beam at a wavelength of approximately 589 nm and four such beacons are required by the telescope, while six laser beacons may be required for specific instruments.

They will be mounted on four laser stations (each of which can host up to two lasers) around the rim of the primary mirror in a side launch configuration. The laser stations and design volumes are shown in orange in Figure 3.183, along with a schematic 3D-view of a laser station, populated with two lasers (baffles omitted).

Each laser consists of a source that generates a powerful laser beam with suitable properties for sodium excitation and a relay that projects it onto the sky to create the artificial star.

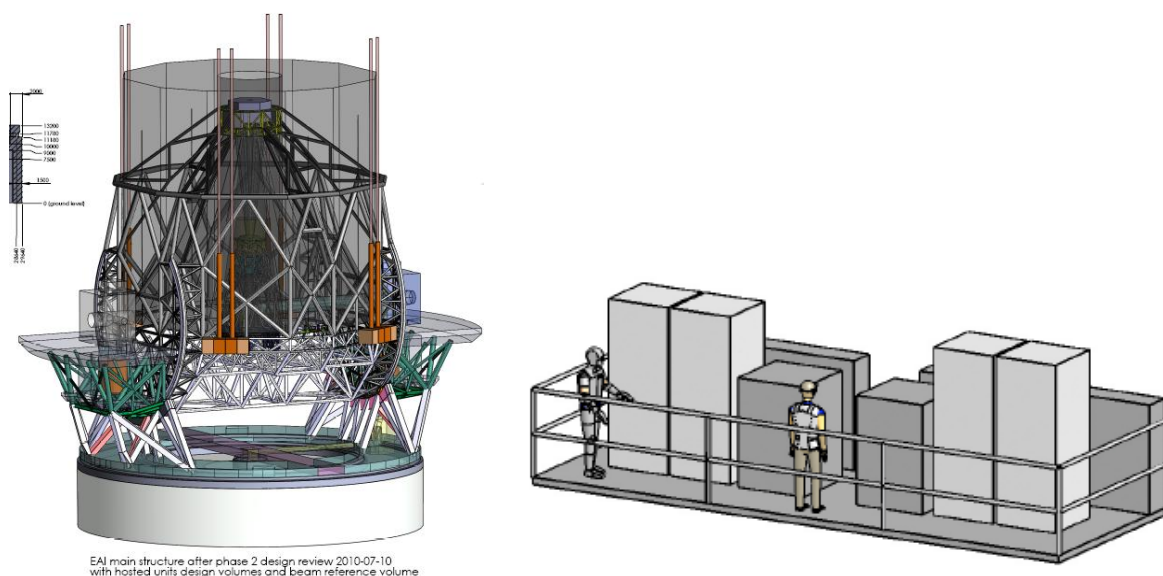

Figure 3.183. The laser stations and design volumes.

3.10.2 PERFORMANCE REQUIREMENTS

The laser guide star specifications are largely driven by the post-focal AO systems incorporated in the instrumentation. The laser launch location has been analysed by the adaptive optics community in the context of GLAO, MCAO and LTAO (Ground Layer, Multi-Conjugate and Laser Tomography Adaptive

Optics). The side-launch configuration was selected as a result of these studies. This mitigates fratricide at the expense of a higher laser power requirement and a wider field of view on the detectors.

Extensive simulations and tests on a dedicated test bench funded by ESO at the Dominion Astrophysical Observatory have shown that with 1000 photons per Shack–Hartmann subaperture at the laser detector, the centroiding accuracy necessary for all flavours of AO can be achieved. The final requirement on photon return flux from each laser is 5 million photons $s^{-1} m^{-2}$ at the straight-through Nasmyth focus at zenith, in median sodium conditions at the E-ELT site of Cerro Armazones. The angular size of the laser guide star is required to be 1.15 arcseconds under a set of reference conditions. Other requirements include the ability to steer the laser beams to generate and maintain the asterism, pointing, calibration functions such as wavelength detuning and diagnostics.

When operating away from zenith, the laser photon return will be reduced due to increased airmass and atmospheric extinction and the increase in the angular size of the laser guide star that will reduce the sodium excitation efficiency. In developing the requirements, an approximate reduction in the return flux by a factor of three at a zenith angle of 60 degrees was taken into account.

In addition a sodium layer variability study at the University of British Columbia is being partially funded by ESO.

3.10.3 CONCEPT

The concept is illustrated in Figure 3.184. The source has an optomechanical interface with the beam relay and projection components. The Laser Projection Subunit (LPS) expands the laser beam and launches it into the atmosphere. The laser projector provides other functionality including pointing, fast and slow beam steering, focus, and diagnostics. The lasers will be stand-alone, identical, modular pieces of equipment. Control will be via the interface with the telescope control system.

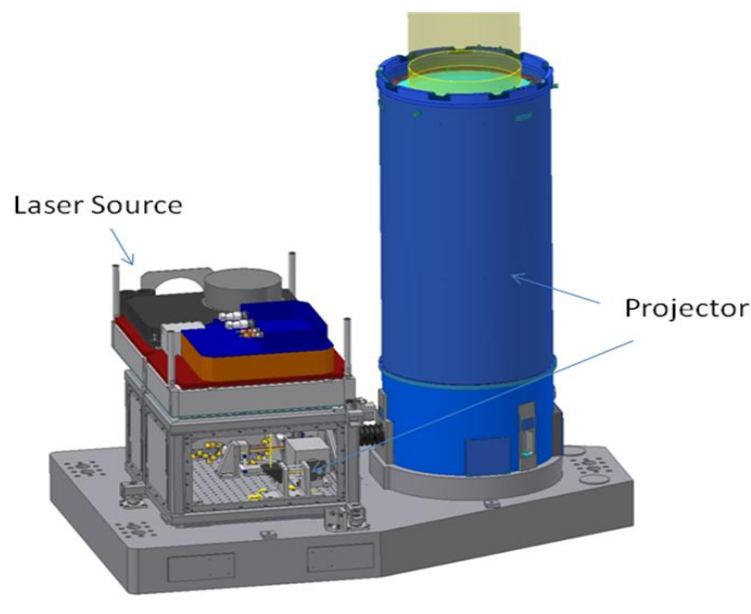

Figure 3.184. Laser guide star unit of the Four Laser Guide Star Facility (main optomechanics).

3.10.4 LASER SOURCES

The E-ELT baseline solution for 589 nm light generation is the same as that adopted for the VLT. Topica GmbH (Gräfelfing, Germany) has been selected to produce the laser units for the VLT adaptive optics facility of the VLT, and their design concepts are described below. Topica subcontracts the manufacture of the Raman fibre amplifiers to MPBC (Montreal, Canada).

Raman fibre amplifiers at 1178 nm with frequency doubling are currently the most promising technology to produce high-power narrowband laser light at 589 nm (yellow). Other technologies, such as VECSELs (Vertical External Cavity Surface-Emitting Lasers), are being investigated in order to mitigate risk. Experience gained from, hopefully, thousands of operating hours on UT4 of the VLT is expected to be available by the time the E-ELT lasers are procured.

The fibre amplifier technology is very attractive since the light runs entirely in glass and hence there are no exposed surfaces that need to be aligned or become dirty over time. The fibre amplifier is followed by a resonant frequency doubling stage which is commercially available. Fibre amplifiers typically feature very high beam quality, which both ensures good frequency doubling efficiency and enables small spot sizes when the beam is projected onto the sky.

A seed laser unit working at 1178 nm with a line width of only 1 MHz is amplified using a two-stage high-power polarisation-maintaining Raman fibre amplifier pumped at 1120 nm, followed by a frequency-doubling non-linear crystal that creates the 589 nm light. The output beam is directly fed into the laser projection subunit. The pump lasers are commercially available 19-inch rack-mounted units and can be replaced within a few hours of work, as can be the laser head.

The technology has been demonstrated at ESO and at Toptica and a contract is in place to produce four 20 W systems for the VLT with a pre-production unit (provisional acceptance in early 2012). Many of the components used in the laser are commercial off-the-shelf items.

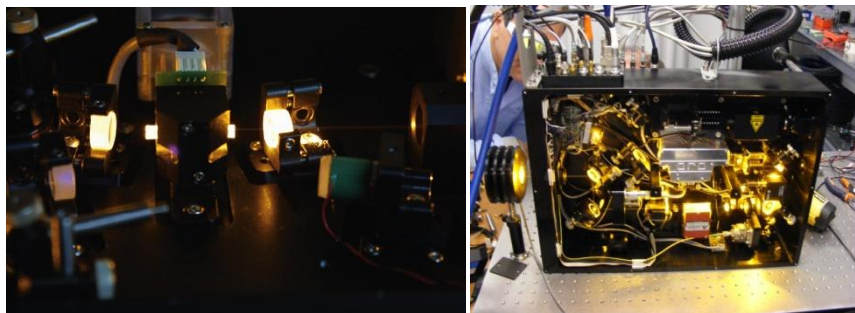

Figure 3.185. Yellow light from a 50 W demonstration in the lab.

With the exception of the 1178 nm seed laser and the 1120 nm pump lasers that are located in the electronics cabinet adjacent to the laser, the rest of the components are housed in the 900 mm × 700 mm × 385 mm laser head with a mass of 85 kg.

The lasers require cooling with a stable flow rate and temperature. Each of the lasers will be provided with a separate heat exchanger/cooling module located on the laser station to buffer against pressure and temperature variations of the telescope coolant.

3.10.5 LASER PROJECTION SUBUNITS

The main requirements are laser beam propagation, beam expansion to an output diameter of 22 cm (30 cm clear aperture), pointing, large-amplitude slow beam steering, small-amplitude fast beam steering (may be required for GLAO mode of telescope), variable focus control, diagnostics including laser power monitoring, mechanical and structural support, enclosure, stray light control and baffling. The optomechanical design is required to be essentially invariant under changing gravity, environmental conditions (particularly temperature and air pressure), and optical power density.

In the baseline design, the main parts are:

- mechanical structure and enclosure;
- beam relay and diagnostics;
- launch telescope;
- control electronics; and
- baffle towers.

A design study of the laser projection subunits was performed during the E-ELT phase B by the UK Astronomy Technology Centre. ESO is also procuring a launch telescope as part of the VLT adaptive optics facility currently being manufactured by TNO in the Netherlands.

3.10.5.1 MECHANICAL STRUCTURE AND ENCLOSURE

The mechanical structure provides support for the optomechanics and a stiff interface for mounting all or part of the laser source subunit. The enclosure provides environmental protection and partially shields the optomechanics from external loads, e.g., wind. The enclosure also provides some thermal insulation to reduce heat dissipation in the dome.

3.10.5.2 BEAM RELAY AND DIAGNOSTICS

The beam relay expands the laser beam diameter, provides variable focus, fast tip-tilt beam steering, and diagnostic functions including laser power.

3.10.5.3 LAUNCH TELESCOPE

The launch telescope is shown as the cylindrical blue structure in Figure 3.184, illustrating the Laser Guide Star (LGS) unit concept. It is approximately 1.4 metres high and 50 cm in external diameter. Some functions of the launch telescope include afocal beam expansion, large-amplitude slow beam steering over an angular diameter of 8 arcminutes with respect to the E-ELT optical axis, and conversion of the beam polarisation state to circular. The telescope is required to maintain excellent optical quality of the wavefront over all operating conditions.

In the baseline concept, the launch telescope is a Galilean refractive design with an actuated turning mirror, providing very precise beam steering to correct for changes in the pointing of the laser beams necessary to generate the required asterism and to compensate for flexures and movement of the structure (possibly in conjunction with a feedback sensor). It also handles the differential rotation of the asterism with respect to the field of the telescope or the pupil.

3.10.5.4 BAFFLE TOWERS

Baffles are required mainly to reduce stray light in the dome. The length of the baffles is a trade-off between stray light and degradation of the optical beam by the baffle. The baseline proposal is a 15-metre tube manufactured out of commercially available ventilation ducting, however the optical quality of this solution requires further analysis. At the top of the tubes a shutter system stops dust reaching the top lens. The system has been analysed for earthquake and extreme wind loading (50 ms^{-1}) and the stresses in the baffles remain well below the yield limits for steel.

3.11 ADAPTIVE OPTICS CALIBRATION UNIT

The Adaptive Optics Calibration Unit (AOCU) is requested by the post-focal adaptive systems for periodic re-calibration of the interaction matrices between the wavefront sensors and the integrated telescope and post-focal adaptive mirrors.

The AOCU is required to be able to accommodate artificial sources within a 7-arcminute field of view, with at least three wavelengths: LGS, NGS-visible and NGS-infrared, with a wavefront quality at the Nasmyth focus close to the diffraction limit.

The adaptive optics calibration unit is foreseen to access the volume reserved immediately below the quaternary mirror to reach the $f/4$ focus of the telescope. The focus is inside the quaternary unit and the expanding beam proceeds towards the tertiary mirror. The calibration unit creates artificial sources at the side of the central tower and projects them on a small mirror positioned close to the quaternary mirror. An optomechanical relay system inserts the source light beam inside the telescope train when the AOCU is in operation.

The dimensions of the system are constrained by the optical design as the folding mirror should not vignette the returning beam from tertiary to the quaternary mirror.

3.11.1 OVERALL SYSTEM DESCRIPTION

The optical design of the projection unit is established and it reproduces both the natural and the laser focal planes (including the extensive differential defocus). The design has been contracted to Active Space to elaborate at the conceptual design level.

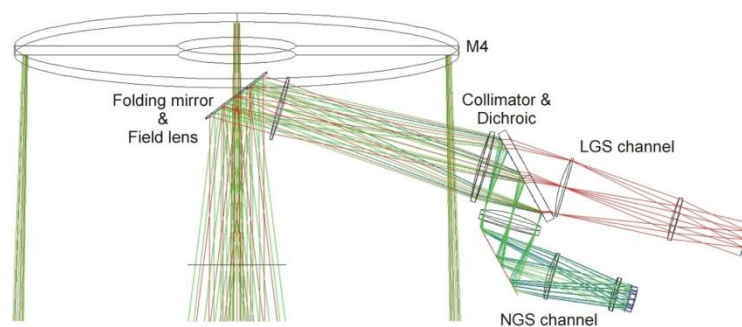

Figure 3.186. Optical design of the beam projection unit.

A trolley system is used to translate the folding mirror and the field lens into the centre of the field directly below the quaternary mirror.



Figure 3.187. Adaptive optics calibration unit trolley and structure supporting the projector.

3.11.2 CHALLENGES

The location of the adaptive optics calibration unit is considered as challenging due to its proximity to the quaternary mirror. The design of the unit is considered conceptual for feasibility purposes. The telescope adaptive systems are considering on-the-fly adjustments to the interaction matrix. This is also under study by some instrument consortia. The calibration unit remains an option that will continue to be studied in detail, although it may not be included in the first light capabilities of the telescope.

3.12 SYSTEMS ENGINEERING

Systems engineering encompasses a number of services and deliverables to the project. Deliverables include high-level requirements, structures, interfaces, the control strategy, technical budgets, and performance estimates. Services focus on the processes required to establish and monitor the system configuration while allowing for its controlled evolution through the project lifecycles. Services also include flowing down requirements from top to lower levels, defining and coordinating interfaces, as well as supporting the preparation, release, and verification of specifications at all levels. Last but not least, Systems

Engineering is relying extensively on GTC technical time (24 nights so far) to build up field experience with phasing, and to support the design of the control strategy.

As for performance characteristics and implied tolerances, two critical aspects of the system need to be considered. On the one hand the increase in the plate scale of the telescope to $3500 \mu\text{m arcsec}^{-1}$ partially relaxes mechanical tolerances at the seeing limited focal plane. On the other hand the need to deliver diffraction-limited performance critically affects almost all components of the telescope. Furthermore, the quasi-static deflections of the telescope are incompatible with the performance requirements without employing some kind of active optics. Furthermore, the correction of dynamic disturbances requires the presence of fast steering and deformable elements.

The performance analysis therefore embeds within it a control strategy that exploits the presence of the adaptive quaternary mirror without which the telescope will not be operable even in “seeing-limited” mode.

At prescription the telescope is largely aberration free, providing a diffraction-limited focal surface at all wavelengths.

3.12.1 TOP-LEVEL REQUIREMENTS

The top-level requirements for the E-ELT observatory were elaborated by a team around the project scientist and have guided the telescope project throughout the design phase; quoting: “The top-level requirements are based on the needs posed by the astronomical research for which the E-ELT is being built.”

The lifetime of the E-ELT is 30 years and it is expected that major upgrades will be undertaken during this lifetime.

The telescope, being adaptive, should be compatible with 0.7-arcsecond seeing and relatively short coherence times (of order 5 ms). Without reproducing the bulk of the level one requirements document the overall performance of the system is expected to be well within the standard telescope range. Pre-setting, tracking and ranges of operation are all evolutions of those of the 8-metre generation telescopes.

Excluding the size of the telescope, a complex interplay of requirements that arise from the science cases needs to be managed.

The performance specified to be achieved after the post-focal adaptive optics drives the telescope deformable mirror to deliver near-diffraction-limited performance (Strehl ratio > 70%) and laser guide stars have to be provided as almost complete sky coverage (99%) is expected in some of these modes.

The requirement to perform high-contrast imaging at relatively short wavelengths with a segmented telescope is a challenge in controlling of the edges of the individual segments both during the polishing stage and later during phasing. As is discussed in the section on the primary mirror, polishing the edges of any optical element is particularly difficult.

The requirement for the telescope itself, rather than the instruments, to acquire targets all over the observable sky and be able to start a ground layer adaptive optics system establishes the need for a telescope adapter hosting guide probes for natural and laser guide stars.

The requirement on the instrument complement and exchangeability drives the size of the Nasmyth platforms and the need for pre-focal stations able to distribute the telescope beam to multiple instruments.

The specific scientific requirements on the instrument suite, elaborated together with the Science Working Group, form the basis of the developed instrument roadmap.

The narrow-field, high-resolution, ultra-stable spectrograph top-level requirement drives the need for a coudé focus. This is not an absolute requirement and alternate solutions may be feasible for such an

instrument. However, all necessary provisions have been included in the telescope design for implementing a coudé train.

Requirements on the instrument maintenance and calibration, as well as on the science operations call for an operations model expanded on, but largely similar to the successful VLT one. The data flow from the E-ELT does not represent a challenge compared to the survey facilities operated by ESO.

Finally, the required high scientific output calls for a stringent site operations model. Telescope and instrument downtime should be minimised, leading to a finely tuned site operation concept, inspired by that of the VLT.

3.12.2 LEVEL ONE REQUIREMENTS AND SYSTEM ARCHITECTURE

The cascade of the top-level requirements to telescope design requirements is captured in the extensive level 1 requirements for the telescope, which are owned by the telescope lead systems engineer.

Requirements (down to contracted level), their hierarchical relationships, justification and verification methods are entered in a DOORS database. The consistency of the requirements with the specifications has been checked by internal and external (for the dome and main structure) reviews. The requirements placed on the adaptive mirrors have been subject to intense scrutiny by designers of the post-focal adaptive optics systems being worked on by the astronomical community.

The systems architecture has been consolidated through several iterations. Having been initiated bottom-up, it is product-oriented and reflects the hardware rather than the functional architecture. Systems engineering maintains a project dictionary defining each element of the architecture.

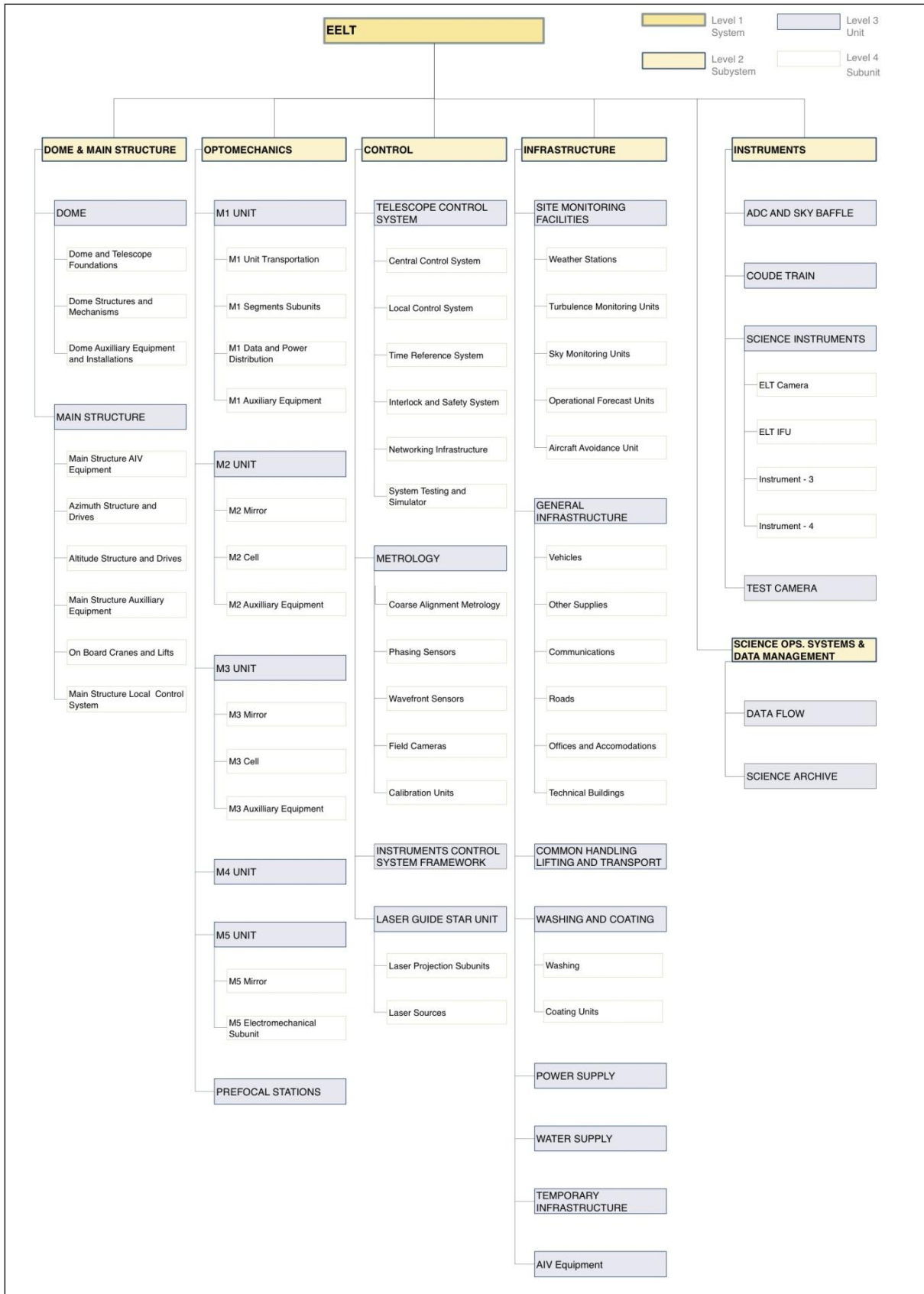

Figure 3.188. E-ELT product architecture (physical items, to level 4).

3.12.3 SYSTEMS ENGINEERING PROCESSES

Systems engineering also endeavours to provide a number of services and tools for the project in order to manage technical complexity. Besides defining architectures and models, this includes, most notably, requirements, interface and configuration management.

Requirements are entered in a DOORS database maintained by the requirements analyst. Every requirement has a number of attributes, including its planned verification method and its justification. In addition, the systems engineer, the requirements analyst and the work-package managers concerned jointly establish the hierarchical links between individual requirements across the entire system. Currently the database contains 76 modules for a total of close to 20 000 objects and 2700 links. Regular inspections are conducted to track the evolution of the database and perform sanity checks (e.g., suspicious links, number of TBCs and TBDs [To Be Confirmed and To Be Done]). The number of links and requirement rationales is expected to increase significantly in the early phase of construction, with the release of supply specifications. Not so for requirements themselves — at least not substantially — as studies and prototype specifications are made obsolete and replaced by the final supply or production ones.

The status of compliance, of waivers and changes is checked through compliance matrices to be provided by contractors and updated at major milestones (e.g., reviews).

The tool is used to produce ready-for-release contractual specifications, including verification attributes, from the content of the database. It can also generate internal justification reports, and template compliance matrices for contractors to complete during execution of their contracts.

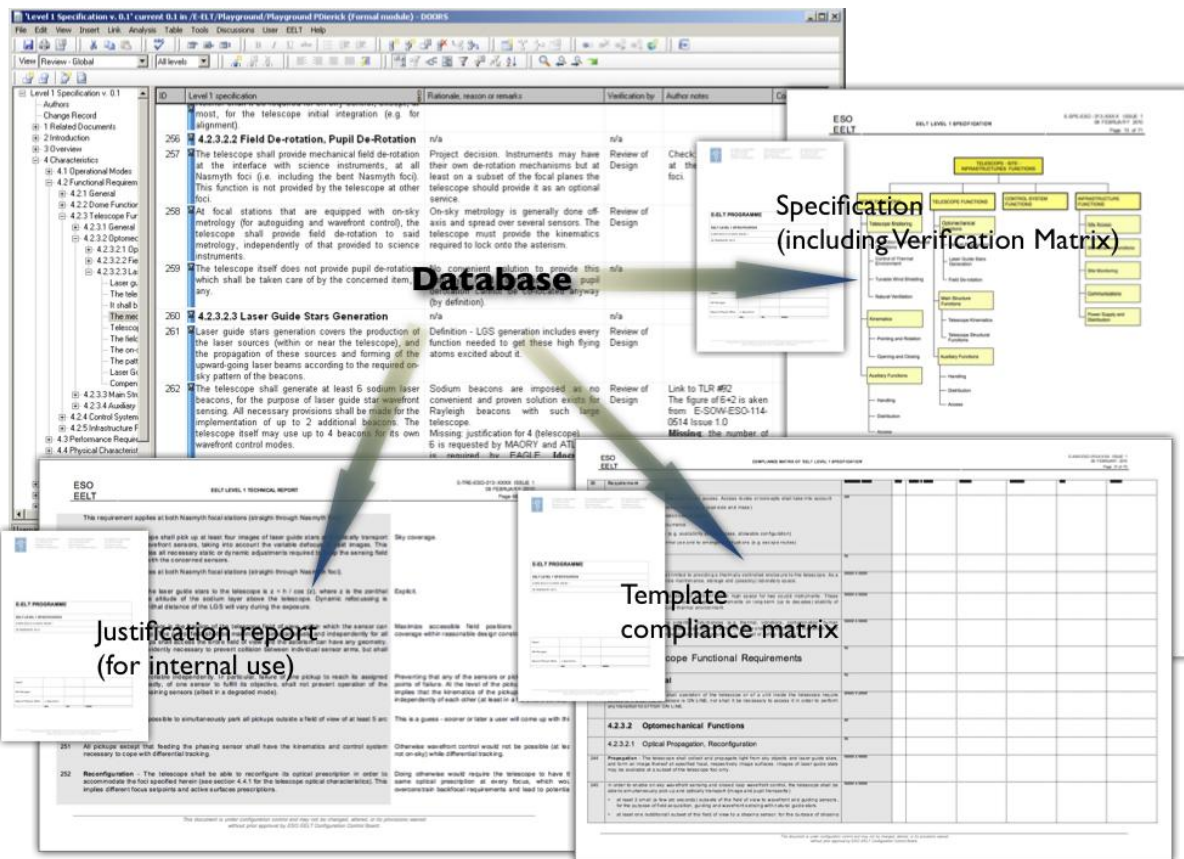

Figure 3.189. Specifications, reports and templates are directly exported from the DOORS database.

The database feeds the project archive, but the latter remains the authoritative source of information. Contractors only receive documents released by the project and have no access to the database.

Interfaces are owned by the interface manager and prepared jointly with the work package managers concerned. They are defined and controlled through an *N*-squared diagram. Interfaces also include design volumes. The interface manager also takes an active part in verifying compliance.

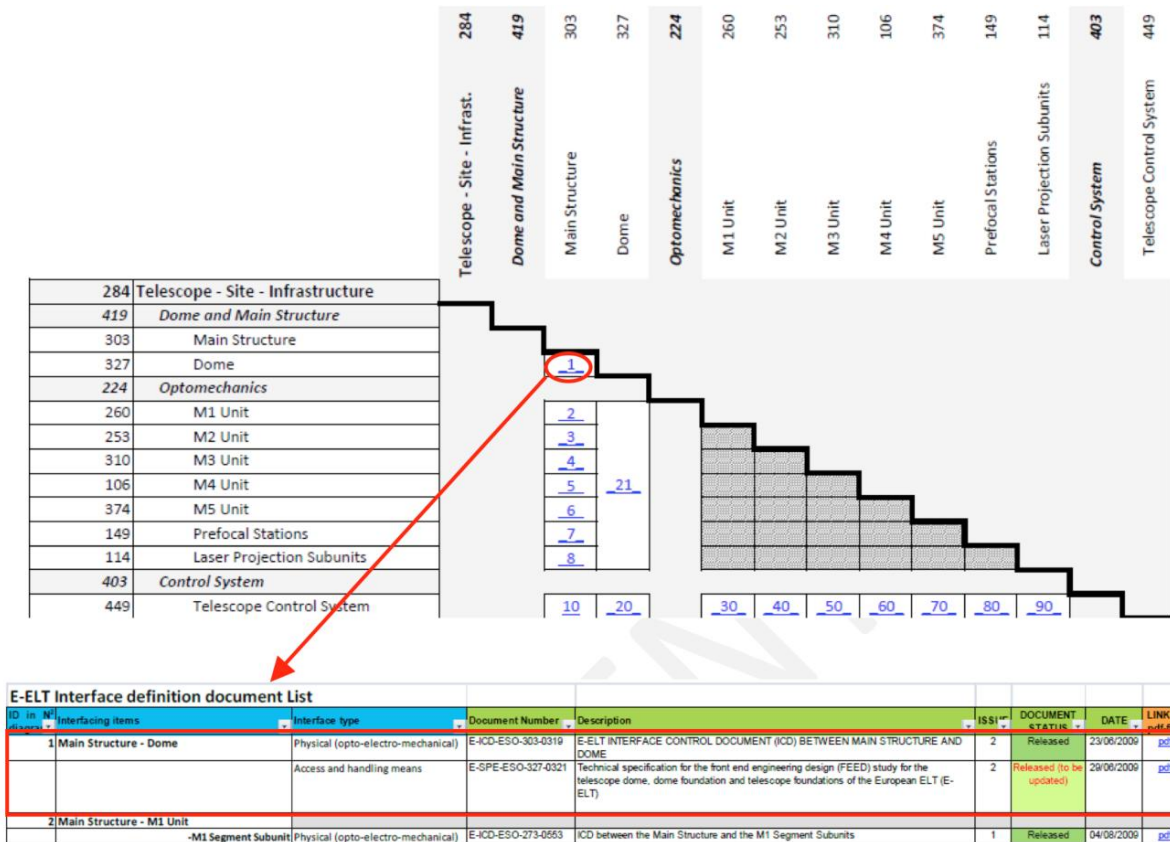

Figure 3.190. Section of the *N*-squared diagram and link to the E-ELT interface document list.

Configuration management supports the definition of the configuration and is responsible for configuration control and change management. The information is structured according to the product architecture. Documentation items are introduced into this structure and procedures are defined to identify and authorise (reviews, signatures) them. They are saved and stored, with controlled access where required (e.g., confidentiality).

Configuration Item Data Lists (CIDLs) are used to identify the documentation items defining a major components of the system. This concept will be extended to include contract CIDLs, in order to identify and track the formal basis of supply contracts. The overall set of CIDLs, organised according to the system architecture, defines the project baseline. CIDLs are updated at all major milestones, and will be integrated into the project.

The processes described above are supported by a tool that has been implemented as a customisation of a commercial database-based product data management software (ARAS/INNOVATOR using MS-SQL as database). In addition, for easy access the data are also formatted and published as web pages (password protected).

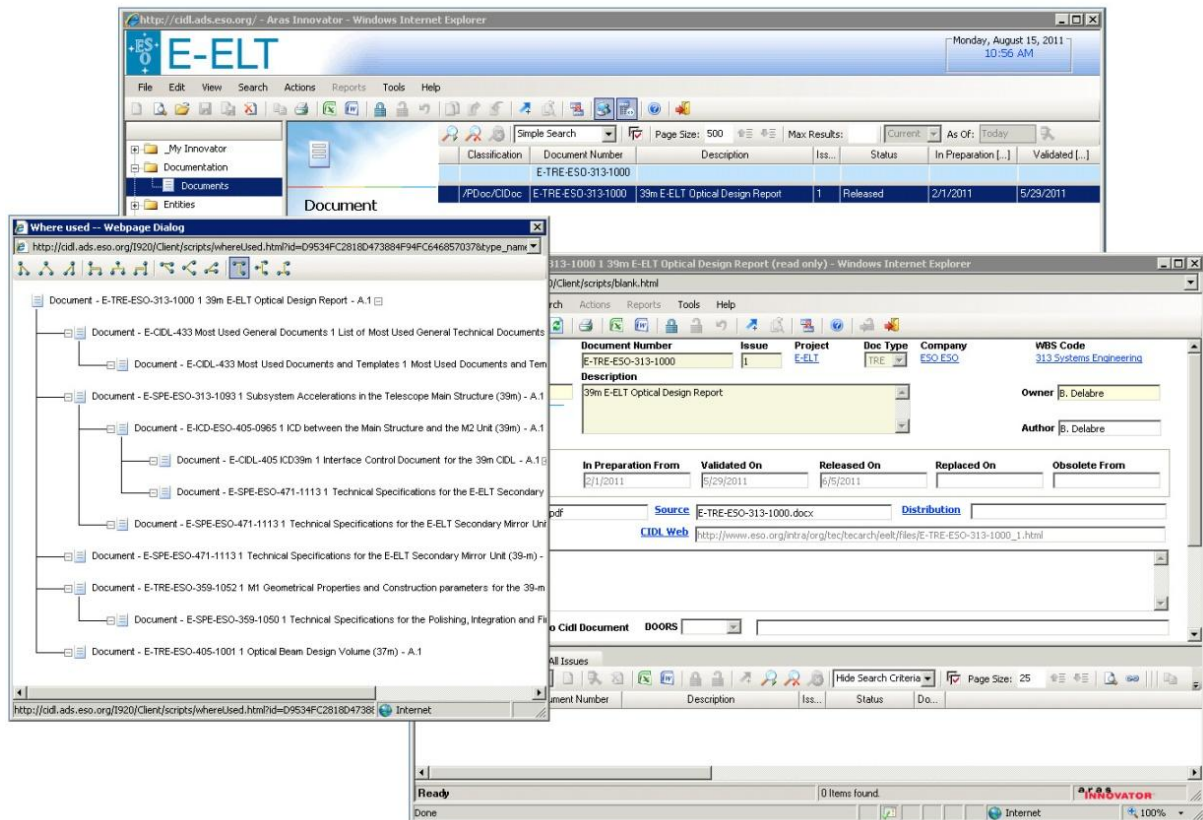

Figure 3.191. Example of use of the CIDL tool in a “where used” analysis.

The change process handles change requests and requests for waiver. Currently it is a manual process using forms and Windows Excel tables for the monitoring. Changes and waivers may result from internal requests as well as external requests from subcontractors. Impact is traced by Systems Engineering through the CIDL tool (“where used” analysis) and the DOORS requirements database (links), the request classified as minor or major, then a technical analysis is performed, leading to a Configuration Control Board recommendation to the project manager — after review by a team of expert if deemed necessary. Metrics are regularly reported in quarterly project reports.

Last but not least, Systems Engineering is actively involved in the preparation of specifications and statements of work, and generates and maintains a number of high level specifications (e.g., level 1 specification, environmental conditions, standards), document templates, procedures, guidelines, and recurrent item requirements.

3.13 CONTROL STRATEGY

With three powered surfaces, tens of degrees of freedom in the system (excluding surface modification and treating the primary as phased) the telescope control is largely under-constrained by the optical sensitivity to rigid body motions and the optical figures of the mirrors. This creates the freedom to manoeuvre the telescope within its optical kernel without impacting the delivered optical quality. The control strategy takes advantage of this to allow the massive secondary mirror to be mounted on position actuators of relatively coarse resolution (micrometres) with respect to its high optical sensitivity. The management of the optical kernel is used to maintain the diffraction-limited performance under dynamic disturbances that would otherwise require continuous adjustment of the position of the secondary mirror. By minimising the work done at the secondary mirror unit we also remove the need for coolant at the level of the M2, thereby mitigating a leak risk.

The telescope is operated in permanent closed loop using three natural guide star guide probes equipped with Shack–Hartmann arrays. This is the same strategy used at the Unit Telescopes of the VLT, just with additional probes.

The control strategy has been developed, working with a sophisticated optical model for the telescope which includes ray tracing of the system, taking into account misalignments, and which closes the loop on the various degrees of freedom (actuators) using wavefront sensors that are positioned in the focal plane as per the pre-focal station (adapter) designs. Furthermore, this model allows the simulation of failure modes such as blocked units. Moreover, actual observing sequences extracted from the operations logs of the VLT have been used as representative cases of telescope usage.

Adaptive telescopes are not new; the MMT and the LBT already have adaptive secondary mirrors. However, these telescopes have exchangeable secondary units and therefore the adaptive mode is but one form of the telescope operations. The E-ELT is different and adaptive is the only mode of operation, albeit at a variety of spatial and temporal bandwidths.

For the sake of clarity, two adaptive modes are considered in the error budget and the control of the telescope. The first is the mode that the telescope engages in when it is using its own guide probes and sensing systems and stabilises the focal plane to meet certain average requirements. Depending on the optimisation made by the telescope control system, this mode may be considered either as a GLAO (Ground Layer Adaptive Optics) or SCAO (Single Conjugate Adaptive Optics) mode. The second mode, expected to be most common, is the higher-order adaptive correction in which instrumentation sensors are used to determine a request to the telescope adaptive components. In this mode, which may serve Extreme Adaptive Optics (XAO), MCAO or LTAO, the telescope provides capabilities for image enhancement to the post-focal instrumentation by commanding the quaternary deformable mirror.

With a view to the longevity of the control system and the safety of the telescope and with the need for clear interfaces to instrumentation, the project has determined that it is best to consider the adaptive systems embedded in the telescope as telescope subsystems providing services (via the telescope control system) to instrumentation rather than as systems directly addressable from instrumentation. The wording chosen to describe this doctrine is that *the E-ELT is conceived and operated as an adaptive telescope and not as a telescope with adaptive optics*. This doctrine has no perceivable performance impact but does require great care in systems engineering and collaboration between the telescope engineering team and the more instrument-oriented adaptive optics community.

The telescope performance has been analysed using a variety of tools. Currently, the models are being updated to the 39-metre baseline; complete performance estimates of the baseline design are not available yet. However, in the specific areas where the change of baseline is expected to have a measurable impact, analyses have been made. In most but not all cases, the current baseline fares more favourably than the former. The higher conjugation altitude of the M4, together with a slightly higher sensitivity to decentring of the optics due to the faster f /ratio of the primary, have negative impact on performance. This is more than compensated by the reduced cross-section of the secondary mirror unit, which plays favourably against the error source that was dominating the former baseline (M2 wind-shaking).

Detailed adaptive optics simulations have been performed at ESO and within the instrumentation consortia to show that the telescope systems as specified are largely capable of reaching high Strehl ratios in the various AO modes. The quaternary and M5 have been specified to be able to correct atmospheric errors to the diffraction limit. Depending on the exact configuration of the natural and laser guide stars, various figures can be extracted from the simulations for the final appearance of the focal plane.

However challenging the atmospheric issues may be, it is critical to appreciate that the telescope's starting point is to provide a field of view that is, in the first instance, correctable. In contrast to existing telescopes that are largely static or quasi-static in their behaviour with respect to aberrations, the E-ELT, with an extremely fast and segmented primary and with enormous dimensions in the all optical elements, must work very hard to bring the telescope to a state such that the wavefront errors in the focal plane are within the range of the post-focal adaptive systems.

At large scales, the supporting structure will compress and expand both as a result of changing gravity orientation and variations in temperature, both absolute and gradients. Therefore the primary mirror of the E-ELT cannot be considered at any time in the operation of the telescope to be at its nominal prescription. In addition, drifts of the edge sensors, inaccuracies in the support structure, and the daily

replacement of a number of segments all have to be taken into account in establishing the contribution of the primary to focal plane aberrations and be accounted for in the error budget.

3.14 CONTROL SYSTEM

The development of the E-ELT control system is built around the interplay between four threads of activity and follows the overall timeline of the telescope construction project.

Firstly, the E-ELT control system hardware and software solutions are deployed on the VLT; the upgrade of the VLT control system is necessary to address obsolescence of its parts and prepare the La Silla Paranal Observatory to support the Assembly, Integration and Verification (AIV), commissioning and operation of the E-ELT. This activity will yield workable and tested hardware and software solutions for the various ESO contractors building the E-ELT telescope units.

The construction of the various components of the telescope with their own parts of the control system will happen in parallel to the development by ESO of supervision, control and acquisition software. To facilitate the work of the industrial partners, inspection, quality control and integration tests will be carried out incrementally by ESO on a system simulator.

The ESO software quality assurance process will be complemented by formal Independent Software Verification and Validation (ISVV) contracted to industry experts.

Lastly, technical time on the VLT and GTC has been used since early phase B of the project to understand, prototype, test and validate novel control strategies and algorithms required for segmented and adaptive telescopes.

The main performance requirements for the control system are therefore long term; they are robustness, scalability, maintainability and cost-effectiveness.

With the exception of the real-time computer for the adaptive mirrors where the control system is allowed a one-cycle computation and transmission lag, no contribution in the error budget is allowed to the overall system architecture in terms of control performance.

The contribution to the thermal environment is demanding, especially in the case of the primary mirror units where the control system is required (together with the actuation and sensing) to dissipate less than 15 W per unit.

3.14.1 OVERALL SYSTEM DESCRIPTION

3.14.1.1 CONCEPT

The concept for the E-ELT control system has been developed on the basis of the three criteria of scalability, maintainability and cost-effectiveness.

In the area of cost-effectiveness, the project has deemed it critical to avoid imposing standards on suppliers that are foreign to the industrial norms and may require significant software and hardware efforts on their behalf. The hardware and software standards selected are Programmable Logic Controller (PLC) and PXI/LabVIEW using Windows as the development and runtime platform. The only units that are currently considered to require a genuine real-time operating system are the M1 and M4 control systems.

The maintainability of the system has been a critical lesson from the VLT. The tight coupling of hardware and software components enabled elegant solutions to a variety of issues but restricted future upgradability, complicated immensely the maintenance of the code and limited the possible evolution of the system. The selected hardware and software standard platforms come with a large palette of supported hardware interface modules, which will enable the project to avoid developing and imposing bespoke hardware components. The removal of custom-built field equipment from the system configuration,

together with the consistent use of Ethernet as field communication technology, creates clear interfaces that are usable over long periods of time.

The distributed nature of the control system mandates the adoption of an efficient and scalable communication infrastructure. Before selecting a solution the project office commissioned independent studies of existing science software infrastructures to determine whether they fit the bill. Robustness and scalability of the control system is ensured by consistently using an asynchronous publish/subscribe communication pattern across distributed control system components. The project has selected switched Ethernet and DDS (Data Distribution Service for Real-time Systems) communication technologies, which are both defined by international standards organisations and guarantee interoperability between different suppliers. While switched Ethernet is a perennial technological choice, DDS is rather new and, like any other software technology, doomed to obsolescence; the project will maintain independence of the application software with the selected communication technology by using appropriate software abstraction mechanisms.

Lastly, the control system architecture shall follow the State Analysis (SA) approach developed by NASA's Jet Propulsion Laboratory (JPL) for future space missions. State analysis provides software design patterns and a formal analysis process to structure and develop distributed and asynchronous software systems. Contrary to command-based systems, the goal-based nature of SA architecture mandates systematic performance and health monitoring and therefore enables enhanced diagnostics and fault detection capabilities, which are the foundation for condition-based maintenance and timely intervention on failed hardware components.

Extensive design work has been undertaken at a variety of software houses external to ESO to demonstrate the feasibility of the solutions above.

3.14.1.2 TIME REFERENCE SYSTEM

An analysis of the E-ELT requirement has shown that the timing needs are very similar to those of the telecom and financial-trading industries. This is particularly fortuitous as it allows the project to piggyback on those developments.

A GPS-disciplined quartz oscillator forms the basis for the time reference system and the synchronisation signal is distributed using IEEE1588-2008 protocol that is transmitted over the switched Ethernet.

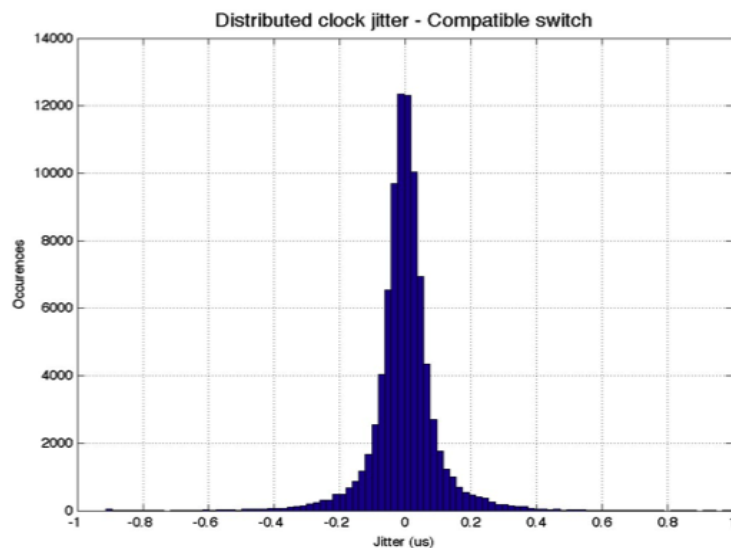

Figure 3.192. Measured jitter on the timing signals across IEEE1588.

Interoperability tests have been performed using Cisco Systems, SIEMENS and National Instruments hardware and a scale-one prototype constructed and validated. The timing residuals from the scale-one prototype units have shown excellent results.

3.14.1.3 INTERLOCK AND SAFETY SYSTEM

Fail-safe PLCs with remote I/O (Input/Output) stations form the basis for the interlock system, providing better diagnostics and normal network access. This is an industry standard and is approved by all national authorities for deployment in human environments.

A scale-one demonstrator unit has been built in-house using hardware donated by SIEMENS and a full-lifetime cycle for the observatory executed without failures.



Figure 3.193. The scale-one demonstrator of the interlock and safety system.

The safety signals travel over normal network cables avoiding the need for powered interlock lines.

3.14.1.4 NETWORK

The complete network infrastructure for the E-ELT has been designed and optimised for existing hardware solutions.

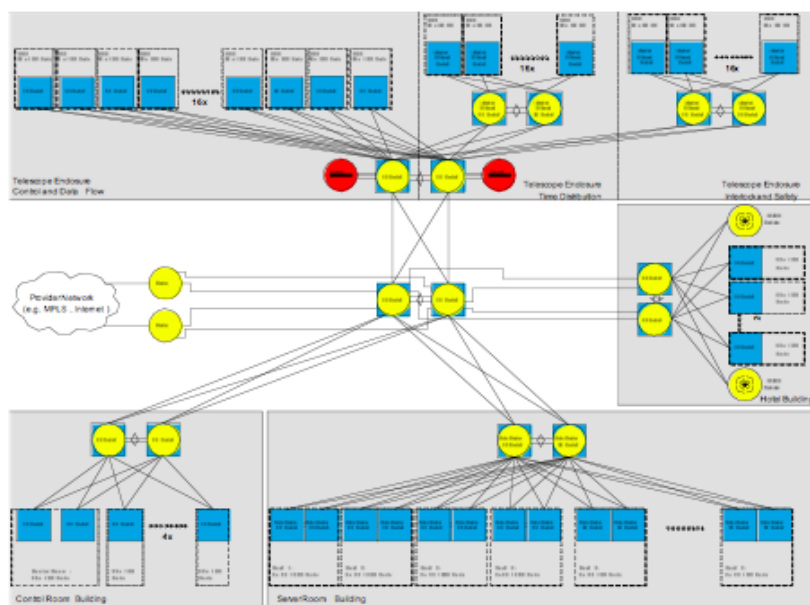

Figure 3.194. The network structure of the E-ELT.

The novel use of Ethernet for high-performance and deterministic transport of control signals has been verified through industrial contracts and demonstrated to be appropriate to meet even the most demanding requirements of the E-ELT.

3.14.1.5 REAL-TIME COMPUTERS

In keeping with the design choices of decoupling the hardware and software solutions and the “no-custom-hardware” doctrine, the solution adopted for the telescope real-time computer is purely PC-based. Two independent studies have confirmed that both the computational and data flow capabilities of existing mainstream multi-core computers and network interconnects meet all requirements for the Real-Time Computers (RTC) of the E-ELT.

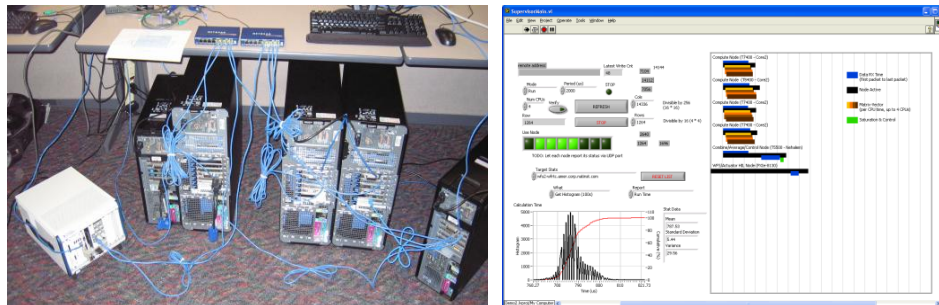

Figure 3.195. Off-the-shelf computers demonstrating the telescope RTC and timing tests on prototype RTC.

3.14.2 SYSTEM PROTOTYPING

The concepts and designs described above have been adopted by Paranal as the basis for the evolution of the VLT control system over the next years. This brings two critical components into play: the battle-testing of the software code in the field and the creation of a single observatory with common hardware and software solutions.

The first stage of this work has already started with the deployment at Paranal of the E-ELT timing system and the successful testing of the DDS-PXI-PLC system at the UT1 dome where it now operates side by side with the VLT control system.



Figure 3.196. The Paranal and Garching UT1 to E-ELT standards dome team following the successful installation.

3.14.3 CHALLENGES

3.14.3.1 MANUFACTURING

The most common failure in control systems is the delay in the software delivery and the associated cost. This risk does not necessarily reflect poorly on the software teams, but rather on the inability of management to contain requirements on something considered malleable and marketed that way.

The risk is mitigated by the project on two fronts: by design, the amount of software to be written is limited and the requirements are decoupled at the interfaces, allowing the suppliers to focus on their deliverables.

The integration of these components into an operable unit is a risk that can be considered to be generated by this approach. This is mitigated by performing serial and incremental integrations of the subsystems and being able to do so from the earliest possible time thanks to the absence of a heavy infrastructure.

Moreover, the adoption of a formal and independent software verification and validation process contracted to industry experts will enable the identification and verification of critical software components and so identify faults early in the development process.

3.14.3.2 PERFORMANCE

The performance risk for the control system is focused on two critical areas: the adaptive optics and the primary mirror unit. The former has been prototyped and a scale-one solution has been built. The latter has been analysed extensively by hardware and software suppliers (National Instruments have built a scale-one solution for the real-time computation problem, and InES in Zurich have analysed the large data distribution problem); a scale-one prototype is currently being built at ESO.

Additional challenges are created by the complexity of the system. This risk, already evident from the limitations of existing architectures, is mitigated by design. This is a common solution adopted by all large infrastructures at this time.

3.15 ASSEMBLY, INTEGRATION AND VERIFICATION

3.15.1 INTEGRATION SEQUENCE

The integration of the main structure and the dome and their verification against functional and performance requirements are undertaken by the respective contractors. This is the same baseline that was adopted for the VLT. Dummy mirror units are foreseen in the main structure contract and the mount will be able to move without the real mirror units installed. In the case of the primary mirror, concrete dummies for each segment are included in the scope of supply. At the time of acceptance of the main structure, targets defining the altitude and azimuth axes of the telescope will be installed. These targets will define the reference frame for the alignment of the telescope optics. The azimuth axis can be established relatively simply by placing targets in the centre of the dummy secondary, dummy quaternary and dummy tertiary mirrors and rotating the telescope while viewing the targets from the centre of the azimuth cable wrap in the telescope pier.

The altitude axis is less straightforward to define since the pre-focal stations will not be installed at this time. Temporary scaffolding will be erected at the Nasmyth platforms of the telescope at the height of the nominal altitude axis. Targets will be located on each side of the telescope and at the centre of the dummy M5. The telescope will be inclined from zenith towards the horizon to determine the altitude axis. As the scaffolding is temporary, the coordinate frame will be translated to reference points on the steel structure of the altitude of the telescope. These reference points will be used (with the necessary transformation — rotation and translation) to determine the positions of optical elements with respect to the altitude axis and to install the pre-focal stations.

Following the acceptance of the main structure, the primary mirror of the telescope will be installed. The mechanical interface from the mirror cell to the mirror units is defined to be good to ± 5 mm. The mirrors need to be located to ± 0.25 mm and ± 0.25 mrad with respect to the mirror cell. The concrete dummies are removed and replaced by the fixed frames of the units. This operation can be performed in stages allowing other activities requiring telescope movement to take place in parallel.

The fixed frames are installed on the M1 cell structure and loaded with dummy mirror segments to ensure that the total weight on the mirror cell is close to the final one. At the same time, the cabling for those primary mirror units will also be installed. The fixed frames will be installed either using the dome crane or a skylift. The fixed frames will be adjusted with the use of laser tracking devices to the necessary precision. The laser trackers will be located on the mirror cell at roughly equidistant locations from the reference marks on the main structure. Normal laser tracker measurement accuracy over distances of

40 metres is better than 0.1 mm and, with more than one reference, the necessary precision of ± 0.25 mm can be achieved. During this operation, the telescope is not assumed to be isothermal as this would impose an operational scenario whereby the air conditioning of the dome is required for the installation and would impose a significant risk for the schedule of the primary mirror installation. The installation procedure takes into account the temperature of the structure that will be monitored with an array of PT100 or equivalent sensors, and modelled in terms of fluctuations. The installation of the frames with the cranes takes 30 minutes per fixed frame while the laser tracker triangulation for a single unit is scheduled to take a further 30 minutes for the linear directions. The installation will take place over 24-hour periods with 30 frames being installed in three days and aligned in three nights while other activities are likely to be reduced, providing for a quieter environment. The entire fixed frame installation is completed when the rotational alignment is performed. This will be done in sectors to reduce the errors due to the small linear dimensions of the segment supports. Once 30 fixed frames are installed and located to ± 0.25 mm, they can be aligned rotationally by locating targets at the periphery and aligning the sector and propagating the alignment towards the centre incrementally. A further four days are allocated to this task. The process requires a degree of continuity in the provision of the segments to be installed.

The installation of the primary mirror fixed frames takes 190 working days assuming seven days per 30 segments. With the primary mirror frames installed, the segments can be inserted into the telescope and connected to the cabling for functional testing. A coated segment insertion is scheduled to last three hours per segment (we expect the first to take significantly longer and the last to be done in approximately one to two hours) including functional testing that can largely be done in parallel. This operation will also take place over three shifts working 24-hour periods and will last 100 days.

The telescope can be inclined and exposed to the sky with a partially-filled primary mirror and, although the sequence establishes a fully populated primary before the installation of the secondary, previous segmented telescopes have never resisted the temptation to observe with a partial primary mirror.

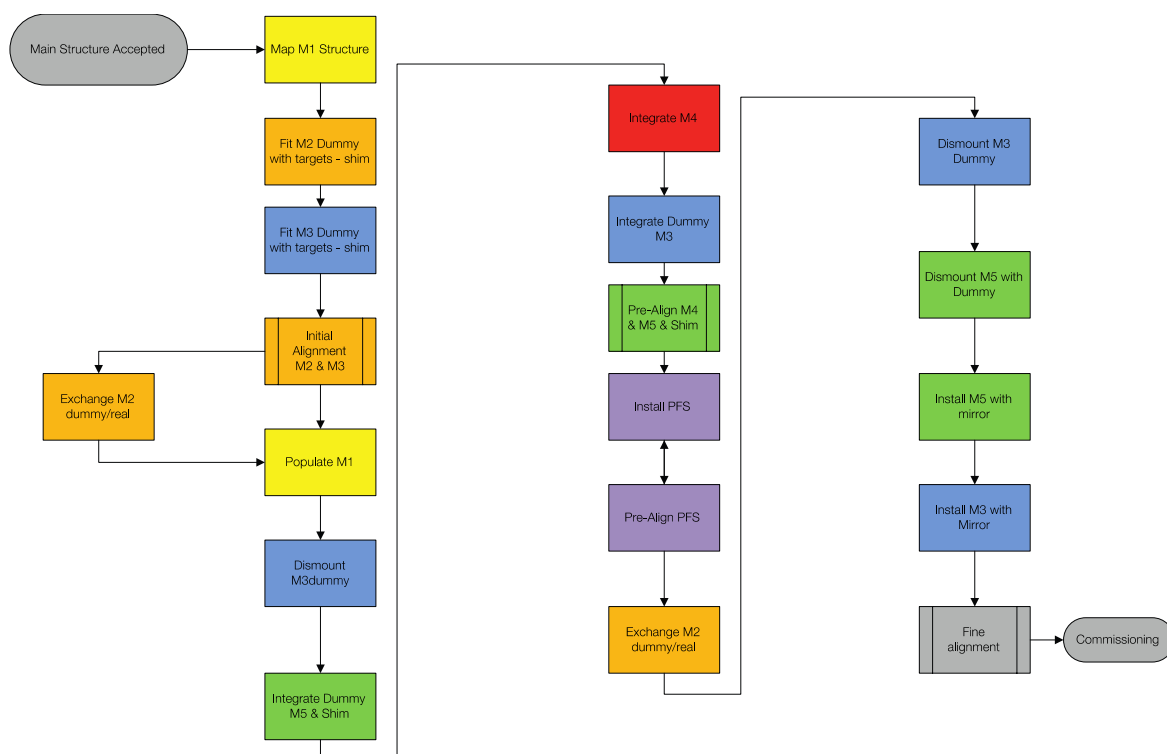

Figure 3.197. Optical pre-alignment flow diagram.

In the enclosure area, the secondary mirror is installed on its cell and functionally tested. Experience from the Paranal primary suggests that 2–3 months should be allocated to this task. The mirror is installed face up into the unit that is then rotated as a whole for the functional test.

The unit will be first tested with the dummy concrete mirror and the installation sequence on the telescope performed in that configuration. The procedure involves the telescope being brought to horizon pointing and the dummy unit removed. The secondary cell with the dummy mirror in place will be inserted into the telescope. The dummy sequence is allocated two weeks in the integration sequence for the telescope, including a re-evaluation of the azimuth axis of the telescope, necessary shimming of the unit and observations of the deflections under gravity load. The dummy mirror will be equipped with targets for alignment and on its “surface” for the laser tracker. The M2 unit is removed and re-installed with the real mirror coated.

With a fully- or partially-populated primary and the secondary mirror in place, the telescope can be left at zenith pointing and, with an open dome, visual observations (piece of paper) can be made at the Nasmyth focus. No provision for instrumentation at that location is made although a simple digital camera would sample the focus adequately for alignment purposes.

The tertiary mirror unit can be installed in the centre of the telescope at any time when the telescope is at the zenith (most of the time). Pre-integration is performed according to the integration procedure and using the integration stand provided by the contractor. The on-board crane in the central tower is used. The unit will be integrated with its dummy mirror and aligned to the azimuth axis of the telescope. Two weeks are allocated for this installation. The unit is removed and re-installed with the real mirror (probably uncoated). Two miniscule flats are mounted on the quaternary and M5 dummies with small adjustment devices (mini-hexapods). The combination of these permits the telescope to project an image towards the Nasmyth platforms to validate basic alignment.

The tertiary is removed and replaced with the dummy unit. The quaternary mirror replaces its dummy as does the M5. All mirrors are installed coated. The units are functionally tested. This operation is allocated one week per unit. The quaternary is aligned to the azimuth axis. The M5 unit is installed and the flange adjusted to align the unit to the altitude axis.

The pre-focal stations are installed mechanically and adjusted relative to the altitude axis positions established for the primary mirror installation. The altitude alignment is checked against the rotation of the instrument bearings on either side of the telescope and the target in the middle of the M5 dummy previously installed. The optical alignment of the bearings is made at the end of the alignment process.

The integration of the quaternary and M5 units will be performed in the dome as soon as they arrive, in the sequence shown in Figure 3.197. Required supporting infrastructure such as overhead cranes, clean areas etc. have been established as part of the FEED contracts.

AIV concludes with the optics of the telescope installed and functionally verified. The telescope is able to point and track and the dome follows it. First light is defined as a filled primary mirror aperture observation that delivers on-axis images on the telescope guide probes that match the external seeing over a 10-minute period of time at an elevation of 45 degrees and a right ascension corresponding to an angle of three hours.

3.15.2 COMMISSIONING

The VLT Paranal model will be adopted for the commissioning of the E-ELT. As described in the control system narrative, the transition of Paranal to E-ELT standards during the construction phase is expected to deliver a control system architecture that is field-tested and functioning. The emphasis of commissioning can then be on the components of the E-ELT rather than the infrastructure.

The commissioning activities will take over after AIV at the time of first light of the telescope. The commissioning personnel, two or three at maximum, will have a continuous presence on site during the final stages of integration to provide support to the AIV team and become familiar with the actual hardware configuration. Although commissioning is not a science-driven activity, it is guided by the science needs and in particular the needs of the first generation of instrumentation.

The commissioning of the telescope will gradually bring successive elements of the optical control loops into operation. The phasing of the primary mirror will be performed with the telescope facing downwind

to minimise the demands on the tip-tilt stages of quaternary and M5. The phasing will follow the path being validated at the GTC.

3.15.3 SCIENCE VERIFICATION

Science verification will be executed as for the Unit Telescopes at Paranal. A close collaboration between the project scientist, the commissioning leader and the commissioning astronomers will provide early access to the telescope to the scientific community without compromising the needs of the commissioning process that are required to complete the job.

3.15.4 CHALLENGES

The AIV and commissioning phases can easily extend as deliverables arrive late or systems fail to function as expected. The most fundamental challenge however is psychological and is the transfer of ownership of parts of a system from one team to another.

3.15.4.1 MANAGERIAL

The managerial risk in AIV and commissioning is in the handover process since contractual acceptance can be a protracted and complex process. The Paranal acceptance procedures developed during the commissioning of the VLT tackle this problem. A clear procedure exists for the Garching team delivering a subsystem to the AIV team to perform this, internal to ESO, transfer without dealing with the contractor. It also provides a clear procedure for the transfer of responsibility between the commissioning team, which is part of the construction project, and the science operations, which is part of the La Silla Paranal Observatory.

3.15.4.2 PERFORMANCE

The performance of the telescope at the start of commissioning and AIV will depend critically on the ability to close the adaptive optics loops at low order (tip-tilt) as early as possible. The infant mortality in the components of the control system is also a potential cause of performance loss. In principle, the staged deployment allows the control system at the subunit level to be exercised during installation. As discussed above, the managerial issues that may arise in the context of changes to the developed solutions are as likely to be an obstacle to a performing system as is the finding of the appropriate solution.

4 E-ELT INSTRUMENT ROADMAP

4.1 INTRODUCTION

The first instruments developed for a new telescope are a critical component if the facility is to achieve early scientific success. Indeed the success of the VLT can be partly attributed to the early delivery of major instruments to the telescope, covering a wide wavelength range and different observing modes. ESO therefore proposes a major programme of instrumentation development in parallel with E-ELT construction to ensure that the facility will be equipped to tackle the key science cases and make major discoveries soon after commissioning. This chapter gives the background information for E-ELT instruments and presents a roadmap for their construction. A matching plan for technology development is then outlined, followed by a management plan for the procurement of the instruments. Finally an Appendix summarises the phase A studies.

The development of the E-ELT science case was accompanied from the beginning by an evolving instrument suite selected to achieve the scientific goals of the project. The merging of the Science and Instrument Working Group reports in April 2006 led to the definition of a number of phase A conceptual studies of instruments. The instrument concepts were defined so that they covered all key science cases defined for the E-ELT. The phase A studies that took place between 2007 and 2010 were then guided by the Science Working Group, and in particular by the Design Reference Mission and the Design Reference Science Plan initiative (see Section 0). The latter assembled nearly 200 community science cases which were subsequently mapped onto the different instrument concepts under investigation. Table 1 lists the studies with details of the consortium and duration.

In the course of 2009, the Science Working Group defined the scientific criteria by which the instruments would be assessed for suitability as first-light and subsequent instruments. Between December 2009 and March 2010, observers from the Science Working Group attended all final reviews of the phase A instrument studies to report at a meeting in April 2010.

First-light instruments were evaluated for their immediate scientific impact, their complementarity with existing high-impact facilities, their scientific flexibility, their secure scientific return and against their coverage of the expected atmospheric conditions. The first-light pair of a diffraction-limited, near-infrared camera ([ELT-CAM], as presented in the MICADO study) and a wideband, integral-field spectrograph ([ELT-IFU], as presented in the HARMONI study) emerged as the clear preference of the Science Working Group in 2010. This powerful combination of an imager and spectrograph satisfied the defined scientific selection criteria very well. These two instruments are able to cover approximately 75% of the science outlined in the science case, as well as offering a solid potential for new discoveries. The impact of the subsequent revision of the telescope baseline to 40-metre-class has not altered this selection. ELT-IFU and ELT-CAM are both versatile workhorse instruments with the goal of achieving high sensitivity and high spatial resolution at the diffraction limit of the largest planned optical-infrared ground based telescope.

Name	PI	Phase A Institutes	Kick-off	Final Review
ATLAS	T. Fusco (ONERA)	ONERA, LESIA, GEPI, LAM, UK ATC	19/09/08	2/02/10
MAORY	E.Diolaiti (INAF OABo)	INAF OABo, OAA, OAP, Univ. Bologna, ONERA	9/11/07	10/12/09
CODEX	L.Paquini (ESO)	ESO, INAF Trieste & Brera, IAC, IoA, Cambridge, Obs. Genève	16/09/08	23/02/10
EAGLE	J.G.Cuby (LAM)	LAM, GEPI, LESIA, ONERA, UK ATC, Univ. Durham	27/09/07	27/10/09
EPICS	M.Kasper (ESO)	ESO, LAOG, INAF-OAPd, LESIA, NOVA ASTRON, Uni. Utrecht, ETHZ, ONERA, Univ. Oxford, FIZEAU, LAM	24/10/07	16/03/10
HARMONI	N.Thatte (Oxford)	Univ. Oxford, CRAL, CSIC- DAMIR, IAC, UK ATC, ONERA	1/04/08	28/01/10
METIS	B. Brandl (Leiden)	NOVA Leiden & ASTRON, MPIA, CEA Saclay, KU- Leuven, UK ATC	07/05/08	17/12/09
MICADO	R. Genzel (MPE)	MPE, MPIA, USM, INAF- Padova, NOVA ASTRON, Leiden, Groningen, LESIA	28/02/08	30/11/09
OPTIMOS- DIORAMAS	O. LeFèvre (LAM)	LAM, STFC RAL, INAF IASF- Milano & OATa, Obs. Genève, IAC, Obs. Haute Provence	3/11/08	30/03/10
OPTIMOS- EVE	F. Hammer (GEPI)	GEPI, NOVA ASTRON, RUN, Univ. Amsterdam, STFC RAL, INAF OATs & Brera, NBI Copenhagen	3/11/08	30/03/10
SIMPLE	L. Origlia (INAF-OABo)	INAF-OABo, Arcetri, Roma, Univ. Bologna, UU, TLS, PUC	30/10/08	04/03/10

Table 4.1. A summary of the phase A studies and the responsible consortia.

The other instruments chosen for inclusion in the Instrumentation Plan were selected to expand the parameter space coverage: extending the wavelength range, the spectral resolution coverage and the multiplex advantage. By adding high-resolution spectroscopy, wide-field multi-object spectroscopy, a mid-infrared imager and spectrograph capabilities, as well as a planet imager, nearly all of the science cases would be enabled. The relative timing and priority of these must be revised periodically in order to allow the instrumentation plan to adapt to the fast-changing scientific landscape over the next decade.

The Science Working Group also recommended the inclusion of more specific modes, such as spectropolarimetry and high time resolution astronomy. Allowing for visitor instruments would further enable the E-ELT to react to important emerging niche science.

4.2 INSTRUMENT ROADMAP

An initial instrument plan, defined in 2010, grouped all instruments beyond first light into a pool from which future selections would be made, providing flexibility against a rapidly changing scientific background. However, meetings and discussions with the instrument-building community in ESO Member States have highlighted the need for a more forward-looking plan, which gives information on instrument planning and selection well beyond first light. This is to enable the community (including funding agencies) to prepare their resource planning and ensure that both staff and funds are in place at the right time. If the construction of a particular instrument is to be deferred for a number of years this is also important information, allowing institutes to undertake other projects in the meantime. For this reason, ESO has decided to develop a *roadmap* for instrument construction that seeks to extend and better define the instrumentation plan for a total of seven instruments. Specification developments, decision milestones and project start dates are selected to try to achieve a balance between giving sufficient information to allow funding, effort and technology development planning while keeping sufficient flexibility to allow for changing scientific priorities.

4.2.1 SCIENTIFIC REQUIREMENTS FOR THE INSTRUMENTS

In the following section we outline in more detail the requirements that emerged from the phase A studies and advisory group meetings.

The diffraction-limited NIR imager, **ELT-CAM**, is based on two concepts from the phase A studies — MAORY and MICADO. The top-level science requirements are for a near-infrared imager capable of sampling the diffraction limit of the 40-metre-class telescope and equipped with a range of standard and narrowband filters. The field of view of the camera should be comparable with the 53 arcseconds \times 53 arcseconds field of MICADO and sufficient to meet the astrometric requirements derived from the science case of that instrument. An adaptive optics system capable of delivering diffraction-limited imaging over a moderately wide field is required to fulfil the science case of this instrument. As mitigation against the risk of late delivery of the MCAO system, it would be scientifically acceptable to deliver the instrument with a SCAO system for the first years of operation. The inclusion of a spectroscopic mode is to be further evaluated during the preparatory phase for the instruments in 2012.

The requirements for **ELT-IFU** are based on those for HARMONI. The extension of the spectral range into the optical, which was a goal for HARMONI, was strongly endorsed by the SWG. The ability for ELT-IFU to operate in seeing-limited conditions as well as at the diffraction limit is also recommended, particularly as the instrument will operate side by side with the diffraction-limited ELT-CAM. The high spectral resolving power ($R \sim 10\,000$) mode is also planned for ELT-IFU, to address science cases in the field of stellar populations and galactic archaeology. The AO module for this instrument is required from the outset of science operations. HARMONI was studied as a client instrument of the LTAO system, ATLAS. This is the scientifically preferred AO mode for this instrument as there are no additional surfaces between the telescope and instrument.

The requirements for **ELT-MIR** are adopted from the METIS study without significant change from their instrument specification. Imaging and spectroscopy at the diffraction limit of the telescope are fundamental requirements for complementarity with the JWST. Key science cases for this instrument require velocity-resolved information for known mid-infrared (MIR) sources and so spectral resolving power in the range $R > 100\,000$ (for example for observations of circumstellar discs) and at lower resolving power ($R \sim 3000$), for the kinematics of high redshift galaxies, is required. *LMN*-band operation is planned for the low-resolution spectrograph and imager, with high-resolution IFU spectroscopy ($R \sim 100\,000$) at *L* and *M* only. The METIS study showed that very high Strehl observations can be achieved in good conditions with just the telescope AO and the on-board SCAO Wavefront Sensors (WFS). Indeed, the highest Strehl ratios are predicted for on-board SCAO using the science targets as natural guide stars. For the initial ELT-MIR configuration, only the on-board SCAO mode will be implemented. However, it is clear that the ELT-MIR should be designed with operation with a full laser guide star AO system for complete sky coverage as a future upgrade, to ensure an advantage over competing facilities.

Efficient use of any telescope for observing large numbers of objects leads to a requirement for Multi-Object Spectroscopy (MOS). Optical MOS instruments have long had success as the workhorses of the

8-metre-class telescopes with NIR MOS instruments now coming online (e.g., KMOS at the VLT, MOSFIRE at Keck). The phase A studies explored the scientific possibilities of high multiplex spectroscopy over the 10-arcminute telescope field via three different studies: EAGLE— a multi-IFU spectrograph with AO-enhanced spatial resolution and spectral resolving power 5000 and 10 000 respectively; OPTIMOS–DIORAMAS — highly optimised for high- z astronomy with high (480) multiplex, high throughput and low resolution ($R \sim 300, 5000$), uniquely with an imaging mode, and OPTIMOS–EVE— more specialised for stellar astrophysics using higher resolving power ($R \sim 10\,000\text{--}20\,000$) optical to NIR spectroscopy with high multiplex and a versatile configuration using single fibres and fibre-bundle IFUs. From these different concepts and their scientific goals, the top-level scientific requirements of a future ELT-MOS will start to be defined from 2012 onwards.

Two high spectral resolution instruments were studied — CODEX in the optical wavelength range and SIMPLE in the NIR wavelength range. The scientific requirements of these two instruments are expected to remain as for the phase A study, with high stability and a fixed spectral format remaining as important top level goals. For an optical ELT-HIRES, based on CODEX, resolving power $R > 100\,000$, high throughput and stability allowing radial velocity measurements in the cms^{-1} regime are key requirements. For the NIR-HIRES, similar spectral resolving power ($R > 100\,000$) is required to meet the science cases. An additional requirement is for high angular resolution to meet science cases such as those on the structure of protoplanetary discs or on the IMF in galaxies. Thus AO is an important scientific requirement for the NIR ELT-HIRES, which also has the technical advantage of reducing the cryostat size. The requirements for the ELT-HIRES capability will ultimately be selected based on one of these two concepts or a combination of both. Refinements to the scientific requirements will be evaluated as new instruments are commissioned on existing telescopes. Of particular interest are ESPRESSO (for the optical HIRES) and GIANO on the Telescopio Nazionale Galileo (for the NIR HIRES).

For the planet-finding instrument, ELT-PCS, the baseline is to implement the science requirements as derived from the EPICS study. Both the IFU and differential imaging polarimeter will be maintained as, of course, will the XAO system. However, this is a fast-moving scientific field and so some significant modifications to the science requirements may be anticipated. These may also be driven by the success of the enabling technology programme for this instrument. Additionally, important inputs to the instrument specification are expected following the commissioning of SPHERE on the VLT.

4.2.2 OTHER REQUIREMENTS FOR THE ROADMAP

In addition to the requirements of the previous section, a number of others emerge from both further scientific discussions with the SWG and practical considerations.

- a. *The three Instruments following the first-light pair should be ELT-MIR, ELT-MOS and ELT-HIRES. These instruments have equal scientific priority.*

This combination covers a broad parameter space with the flexibility to adapt to changing priorities. The Science Working Group ranked these as having equal scientific priority: each contributes substantially to achieving the key scientific programmes of the E-ELT. Therefore their sequencing will be based on requirements readiness and technical maturity.

ELT-MIR has well-defined requirements, a straightforward design and needs relatively little technology development. The key to good performance with this instrument rests with the Aquarius detector which has already been successfully tested in the lab at ESO and will be tried on-sky in 2012 in VISIR. This instrument should therefore be ready to go in 2014 as ELT-3 subject to a technological readiness review in 2013. Currently, three concepts exist for a MOS (OPTIMOS–EVE/DIORAMAS, EAGLE) and two for a high-resolution spectrograph (SIMPLE, CODEX). There is technology development to be done in some of these cases, as well as awaiting results from possible precursor instruments. There is therefore preparatory work to do to define the preferred options and their scientific requirements. This will take most of 2012, allowing a selection of the MOS and HIRES instrument capabilities in 2013 — predominantly on scientific criteria. Further delta phase A design work and/or technology development will be required before instrument starts. In 2015 a decision will be made, based on technological readiness, as to which of ELT-MOS or ELT-HIRES will be ELT-4 and which ELT-5.

- b. *The E-ELT planetary camera and spectrograph (ELT-PCS) is also selected for construction subject to technical readiness.*

This instrument is required for the E-ELT to tackle its principal science case — the imaging and characterisation of Earth-like planets in the habitable zone. The technology required for its construction is ambitious and not yet ready and so the project will begin with technology development for the key components and subsystems. Once the technologies are felt to be at a satisfactory Technology Readiness Level (TRL), the instrument construction project will officially start. This could be as early as 2017 or as late as 2022.

- c. *Instrument projects should start every two years beyond first light.*

The entire suite represents a large investment and so needs to be phased to achieve a smooth spending profile. A roadmap that foresees two instruments at first light, a third the following year, and an instrument start approximately every two years thereafter stays within the available envelope. This phased start will also ensure a phased delivery of the instruments to the telescope that will help to ensure an achievable commissioning schedule, especially during the first years of operation. Nevertheless the plan is ambitious, envisioning delivery of the first four instruments within the first three years of telescope operation.

- d. *Flexibility should be maintained to allow for new concepts and changing scientific priorities.*

This has driven considerations from the beginning and has been stressed by both the SWG and STC in the past. This is incorporated into the roadmap by allocating ELT-6 as an as-yet unspecified instrument whose definition will begin with a Call for Proposals in 2015, subsequent parallel phase A studies and technology development if required, and final selection in 2019. In addition, the precise scientific requirements for ELT-MOS and ELT-HIRES remain to be defined.

- e. *There should be opportunities for new Member States to participate in the programme.*

Four of the seven instruments in the roadmap will be procured by open competition. This will be done in general by issuing a Call for Proposals, selecting which will need to be developed via phase A studies if necessary, and then finally selecting the specific instrument for construction. New Member States will be able to form/join consortia and compete for these instruments. In addition ELT-6 is unspecified and will also be selected by a competitive procedure.

While it is difficult to satisfy all the requirements in a single instrument plan, we believe that the roadmap in Figure 1 provides a satisfactory solution. In particular it attempts to balance a forward look for planning purposes with maintaining scientific flexibility. The following instruments are selected for construction: ELT-CAM, ELT-IFU, ELT-MIR, ELT-HIRES, ELT-MOS and ELT-PCS. Funded work towards the construction of each of these starts in 2012, either by the development of the initial specifications or by the initiation of the research and development programmes required to support them. The final sequence of start dates for instruments beyond the first-light pair (ELT-CAM, ELT-IFU) depends upon a balance of scientific priority and technical readiness.

Year	ELT-IFU	ELT-CAM	ELT-MIR	ELT-4 (MOS or HIRES)	ELT-5 (MOS or HIRES)	ELT-6	ELT-PCS
2012	Decide science requirements, AO architecture.		VISIR start on-sky	Develop science requirements for MOS/HIRES			Call for Proposals for ETD
2013			TRL Review	Call for Proposals for MOS/HIRES			
2014							
2015				Selection ELT-MOS/HIRES		Call for Proposals	
2016							
2017							TRL check
2018							TRL check
2019						Selection	TRL check
2020							TRL check
2021							TRL check
2022 Tel. technical first light							
	Pre-studies taking the form of phase A or delta phase A work and/or ESO-funded Enabling Technology Development (ETD)						
	Decision point						
	Development of Technical Specifications, Statement of Work, Agreement, Instrument Start.						

Table 4.2. The E-ELT instrumentation roadmap.

Table 4.3 shows the roadmap key events year by year.

Year	Key Milestones
2012	Development of specifications and AO architecture for first-light instruments. VISIR start on-sky. Aquarius performance to be evaluated. Develop science requirements for MOS and HIRES spectrometer. Commence technology development for ELT-PCS.
2013	ELT-MIR is reviewed for technology-readiness. Key areas are (1) performance of the Aquarius detector and (2) development of sky-chopping. A decision is made regarding the scientific capabilities required for a MOS, and for a HIRES spectrograph. A Call for Proposals is then issued based on these requirements. Further delta phase A design is then carried out and enabling technology development initiated. First-light instruments (ELT-IFU, ELT-CAM) start.
2014	ELT-MIR project starts, subject to 2013 review. Ongoing ELT-MOS and ELT-HIRES studies.
2015	The allocation of ELT-MOS and ELT-HIRES as ELT-4 or ELT-5 is made based on technical readiness. A Call for Proposals is made for ELT-6. Responses may include reworked designs that were not previously selected, or entirely new instrument concepts. A subset will be selected and funded as further phase A studies.
2016	Start ELT-4. Continue technology development of ELT-5.
2017	Possible start date for ELT-PCS.
2018	Start ELT-5.
2019	An instrument will be selected from completed phase A studies as ELT-6.
2020	Start ELT-6.
2021	Six instruments under construction at this point.
2022	Latest envisioned start for ELT-PCS.

Table 4.3. The key roadmap events.

4.2.3 INSTRUMENT DELIVERY SCHEDULE

The following table shows the instrument commissioning dates. These are selected to have spaced delivery dates and construction periods of approximately eight years. These dates will become contracted delivery dates with consortia, and projects will be structured to meet the delivery schedules.

	ELT-IFU	ELT-CAM	ELT-MIR	ELT-4	ELT-5	ELT-6	ELT-PCS
Commissioning	2022	2022	2023	2024	2026	2028	2025–30

Table 4.4. Commissioning.

The current schedule of deliveries will, depending on whether a coudé instrument is selected, fill all available Nasmyth ports. However, this will not be until 2028–30. A visitor port will therefore be available for at least the first six to eight years of telescope operation.

4.2.4 INSTRUMENT DEPLOYMENT ON TELESCOPE

Figure 4.1 shows a tentative arrangement for the instruments on the Nasmyth platforms and the coudé area. The sizes of the individual items in the figure are scaled according to actual values. In the case of the instruments these values are the allocated design volumes to heavy instruments and post-focal AO modules that were used during the phase A studies (except in the case of the coudé instrument, where the constraints were different).

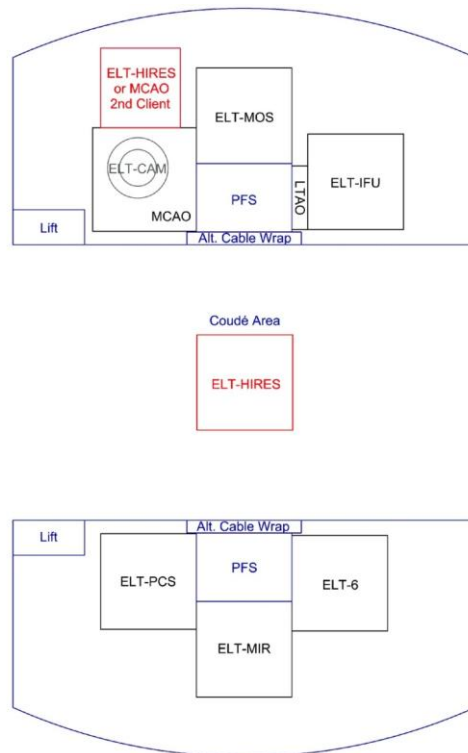

Figure 4.1. A possible arrangement for the instruments on the Nasmyth platforms and coudé area.

The ELT-IFU is shown in the figure being fed by an LTAO module. As already discussed, such a facility could be integrated into the instrument. In that case, the allocated space could vary with respect to what is presented. The ELT-CAM is expected to be fed by the MCAO module in a gravity-invariant fashion and, therefore, will be located underneath the module.

The two instruments placed on the straight-through ports are the ELT-MOS and the ELT-MIR. The former is a large Field of View (FoV) instrument that will use the 10-arcminute field, only available at the straight-through ports. The ELT-MIR will benefit by having only five reflections instead of six, as would be the case if located in a lateral port. The ELT-PCS would also preferably be located at a straight-through port, avoiding M6 in the optical path which, given its inclined position, will introduce a signature in polarimetric observations. If located at a lateral port, a polarimetric calibration unit may be needed for ELT-PCS at the intermediate focus of the telescope.

The ELT-6 is assumed to be located at one of the lateral ports. Finally, the ELT-HIRES, depending on the type of instrument, can be fed by a second port of the MCAO module. In that case this port, already considered in the phase A study, would have to be implemented. Another option is locating the ELT-HIRES in the coudé focal station. Both possibilities are shown in red in Figure 4.1.

4.2.5 ENABLING TECHNOLOGY DEVELOPMENT ROADMAP

The instrument roadmap is supported by a parallel Enabling Technology Development roadmap that is designed to support the instrument selection process outlined above. As the Instrument roadmap evolves, the ETD roadmap will evolve to match the new requirements.

The main input to the ETD roadmap comes from the results of the phase A studies. The final reports of the studies identify the important R&D project areas for each instrument concept. Naturally, the R&D requirements of the instruments proposed range between those with significant development programmes critical for construction of a successful instrument, to those requiring only minor developments of non-critical, performance-enhancing components.

The ETD roadmap will be subject to frequent, possibly major, revision during the course of the instrument construction period due to the changing scientific priority of various capabilities/instruments, the speed of development of key technologies and the possible introduction of new “disruptive” technologies that revolutionise instrument development. Thus the list below summarises our understanding today of the development needs of the instrument suite and is subject to future review.

While remaining flexible and responsive, the principal consideration for the ETD roadmap is that it must support the instrument roadmap by ensuring that any novel component reaches a Technology Readiness Level*** that allows instrument selection and construction to proceed with manageable risks to performance and schedule. This level has typically been TRL 3 for VLT instrumentation and will also be the basis for the E-ELT. Development of technologies to TRL level > 5 is expected during the project. The way in which this goal is achieved is determined by the category of development, according to the following scheme:

Category	Description
A	Components of TRL \geq 3 where the scope of the work is such that the developments can be carried out within the project. These developments and the resources required to deliver them are identified in the management plan for the construction phase of the project. Funding for this is included within the instrument construction cost.
B	Components of TRL < 3 with short development timescales. These developments and the resources required to deliver them to TRL-3 are to be identified by instrument teams in their responses to the Call for Proposals for the phase A or delta phase A study. Funding is allocated from the enabling technologies work package on a case-by-case basis as part of the contract negotiations for the (delta) phase A study.
C	Components of TRL < 3 with long development timescales that are critical to an instrument concept and must be completed before instrument selection. Funding is allocated from the enabling technologies work package after a Call for Proposals for ETD, or award of a Single Source contract if appropriate. Where there is no highly performing fall back option for a given technology, a higher TRL may be required. The key example of this is the MIR detectors for ELT-MIR. Also included in this category are common developments that will be exploited by more than one instrument.

Table 4.5. Description of components per category of development.

In addition to the funding planned by ESO within the instrument budget, ESO will provide guidance and support when possible to the national or International initiatives bringing additional resources to the E-ELT R&D and Enabling Technology Programmes.

Key technologies relating to the instruments on the instrument roadmap are listed in the tables below, Category A developments in Table 4.6 and Category B and C in Table 4.7.

*** ESO TRLs are similar to the NASA scale and run from 1 to 9 with TRL 1 being just a basic concept through to TRL 9 being fully proven through real deployed systems. At TRL 3 a proof of concept has been demonstrated through analytical and/or experimental work.

Technology	Instrument
Novel focal plane WFS	LTAO
Demonstration of pseudo open loop control	LTAO/MCAO/ELT-MOS
Real time Cn2 profile monitoring	LTAO/MCAO
Slanted Volume Phased Holographic (VPH) gratings	ELT-HIRES
Laser frequency comb (optical and NIR)	ELT-HIRES
Fibre scrambling	ELT-HIRES
High stability cryostat	ELT-HIRES
NIR VPH	ELT-MOS, ELT-IFU
Novel roof-pyramid WFS	ELT-PCS
Testing Fresnel and chromatic effects in an optical system	ELT-PCS
Improved deconvolution algorithms	ELT-PCS
Polarimetric error budget, verified by test	ELT-PCS

Table 4.6. Category A developments as identified from the phase A concept studies.

For the Category B and C developments, milestones by which these are required for the resource planning for the E-ELT instrumentation are listed. Category A developments are under the control of the instrument projects and the milestones will be determined within the project. Category B and C developments will be supported in part or in full from the enabling technologies work package.

With the exception of the long-term development of the 4k × 4k science detectors, the two first-light science instruments (ELT-IFU, ELT-CAM) require marginal amounts of R&D and those required will be incorporated into the normal project phases. Common technology developments are required for the AO modules.

ELT-MIR has one long-term development requirement, which is now coming to fruition through the development of the Aquarius detectors for VISIR. Selection of the instrument depends upon the success of this project. Within the instrument project, understanding the ultimate sensitivity reached with this instrument will depend upon further demonstration of the technique of on-instrument chopping to be carried out during the instrument developments.

The majority of the technical developments outlined in the studies of the five ELT-HIRES and ELT-MOS instrument concepts will be carried out within the instrument construction phases or a delta phase A for the instruments. The exceptions are the developments required to support the Multi-Object Adaptive Optics (MOAO) system planned for the NIR ELT-MOS. These are longer-term developments that will be the subject of a separate Call for Proposals.

Finally, ELT-PCS has a substantial, long-term R&D programme required to develop this ambitious instrument to TRL 3 before the official start. The pre-construction phase for this instrument is estimated (based on the EPICS study and the development timescales for SPHERE) to be three to four years.

Technology	Category	Instrument	Required by Milestone	Notes
LGS WFS detectors	C	MCAO, LTAO, ELT-PCS, ELT-MOS	MCAO/LTAO Final Design Review (FDR)	Development of fast read out, low-noise detectors, 1680 × 1680 pixels
Real-time computer	C	MCAO/LTAO ELT-PCS, ELT-MOS	MCAO/LTAO FDR	Computing power, of order of 300 GMAC/s
Deformable Mirror (DM) developments	C	MCAO	MCAO FDR	~ 400 mm diameter, ~ 50 × 50 actuators and the pitch of ~ 8 μm
Detector stability	C	ELT-HIRES	ELT-HIRES FDR	Important for the optical HIRES
84 × 84 actuator DM with 6 μm stroke	C	ELT-MOS	ELT-HIRES FDR	Based on EAGLE requirements
XAO-DM and control electronics	C	ELT-PCS	ELT-PCS start	Development of DM to ELT-PCS spec — high actuator density
WFS camera	C	ELT-PCS	ELT-PCS start	Increase in speed of the existing hardware (by a factor ~ 2) and introduction of the deep-depleted CCDs for better red sensitivity
Speckle-nulling study	B	ELT-PCS	ELT-PCS start	Required to understand the contrast reached by ELT-PCS
Optical de-rotation of the Integral Field Spectrograph (IFS) without introducing Fresnel effects	B	ELT-PCS	ELT-PCS start	Required to increase the performance of ELT-PCS
Aquarius detector	C	ELT-MIR	ELT-3 selection	VISIR on-sky tests
4k × 4k science detectors	C	ELT-CAM/ ELT-IFU	Preliminary Design Review (PDR) of ELT-IFU and ELT-CAM	At quite advanced TRL, funds for testing within ESO planned
Robotic filter/grating exchange	B	ELT-MOS	Selection of ELT-4	Important for the current optical slit mask ELT-MOS concept.
Small diameter (< 100 μm) fibres for high resolving power	B	ELT-MOS	Selection of ELT-4	Important for the current fibre-optical MOS concept

Table 4.7. Category B and C developments as identified from the phase A concept studies.

4.3 INSTRUMENT MANAGEMENT PLAN

4.3.1 INSTRUMENT PROCUREMENT

ESO will manage the E-ELT instrument procurement on behalf of its community and will maintain in-house the technical and management capabilities required to carry out this function. For the VLT, ESO developed and provided standard components (electronics, software and cryogenics) and detector systems, as well as undertaking responsibility for oversight of the external contracts. This model is followed for the E-ELT instrument contracts.

External instrument consortia will receive a Guaranteed Time Observing allocation (GTO) to compensate them for both contributed staff effort and any cash contribution to the projects. One change from the VLT process is that GTO compensation for staff effort will be specified at the time of the Call for Proposals and will not normally be negotiable. Cash contributions from consortia towards procurements will be compensated using a standard formula.

It is expected that the E-ELT instruments will be sufficiently complex, costly and demanding of staff resources so that no single institute, including ESO, will be able to handle their successful construction alone. Therefore the normal project organisation is envisioned to be as follows:

- A consortium will be selected for construction based on either competitive tendering or single-source procurement;
- The instrument project will be defined via an agreement between ESO and the consortium, and by technical specifications and a Statement of Work;
- Project work packages will be distributed amongst a consortium of Institutes in the Member States and ESO, with responsibilities defined in a Memorandum of Understanding (MoU);
- A PI for each instrument will be defined;
- A lead technical institute for the project will be specified. This lead institute will be responsible for top-level project management, systems engineering and the Assembly and Integration Team and will have a demonstrated track record in successfully delivering VLT-class instrumentation;
- ESO will have an oversight role via regular progress reviews and major milestone reviews, and will act as the customer.

Instrument	Procurement Plan
ELT-CAM	As first-light instruments, and considering their necessary integration with adaptive optics, discussions regarding instrument architecture and specifications must be started in 2012. Due to the revised telescope design and depending on the AO approach adopted, some phase A design may also need to be repeated. ESO will therefore plan to contract instrument construction with the existing MICADO and HARMONI consortia, subject to successful negotiation.
ELT-IFU	
ELT-PCS	Competitive tendering for enabling technology development and instrument construction will be applied.
ELT-MIR	Provided technology readiness can be demonstrated in 2013, a mid-IR imager/spectrometer will be delivered as ELT-3. Since the METIS consortium contains most Member State institutes with mid-IR instrument experience (it is essentially the JWST-MIRI team) ESO will plan to contract directly with that consortium.
ELT-4	Competitive tendering for enabling technology development and instrument construction will be applied.
ELT-5	Competitive tendering for enabling technology development and instrument construction will be applied.
ELT-6	Competitive tendering for enabling technology development and instrument construction will be applied.

Table 4.8. Procurement plan for each instrument.

For instruments built by external consortia, it will be essential that consortium leadership in the project brings adequately demonstrated expertise in project management, product assurance, systems engineering and Assembly and Integration Team (AIT) facilities. The organisation of responsibility and allocation of work packages within consortia will be the first step in reaching an agreement for instrument construction. Should agreement not be reached, ESO reserves the right to award the instrument construction to another consortium, or to re-tender.

The basis for E-ELT instrument procurement will be to adopt a competitive approach whenever reasonable. Proposals will then be solicited for the design and construction of an instrument defined in a set of Technical Specifications and a Statement of Work. A basic procurement principle is that all competing instrument proposals should be at a similar level of design before a selection is made. This may require extra studies to be carried out (and hence extra time).

In the case of instruments where a single consortium may contain most, if not all, of the relevant expertise in Europe, ESO will negotiate a contract directly with the consortium. This may also apply in the case where the required instrument schedule does not allow for an extended period of competitive tendering, such as the first-light instruments.

Based on these principles, ESO plans to implement the following procurement strategy for the instruments currently indicated in the roadmap.

ESO may lead a selected project when the instrument characteristics specifically match ESO in-house expertise, and when internal effort is available. This will be done within a consortium, with external institutes responsible for subsystems, and competitive tendering will be used to select these. Any decision for ESO to lead an instrument project will be taken by the Director General.

4.3.2 ORGANISATION OF ESO INSTRUMENT MANAGEMENT

The construction of instrumentation for the E-ELT will be managed by the ESO Instrumentation Division as a major work package within the E-ELT construction project. As such, the Instrumentation Division will participate fully in the E-ELT project work and be under the authority of the E-ELT project management team and project governance.

The E-ELT instrumentation work itself breaks down to the following work packages and work package managers for the construction phase.

Work Package	ESO Manager	Task
ELT instrument programme management	M. Casali	Management of programme
Preparatory work		
Instrument specification development	S. Ramsay	Development of initial instrument specifications prior to consortium selection.
Instrument enabling technologies	N. Hubin	Development of technologies critical for future instruments, prior to instrument consortium selection.
Instrument infrastructure	J. C. Gonzalez	Development of infrastructure required for instrumentation including cryogenic system and interfaces.
Instrument standards and standard subsystems	M. Casali	Review and definition of instrumentation standards
Instrument Construction		
Instrument 1 contract	Not yet allocated	Management of external construction contract
Instrument 1 ESO deliverables	Not yet allocated	Management of ESO internal deliverables
Instrument 2 contract	Not yet allocated	Management of external construction contract
Instrument 2 ESO deliverables	Not yet allocated	Management of ESO internal deliverables
Instrument 3 contract *	Not yet allocated	Management of external construction contract
Instrument 3 ESO deliverables *	Not yet allocated	Management of ESO internal deliverables
Instrument 4 contract *	Not yet allocated	Management of external construction contract
Instrument 4 ESO deliverables *	Not yet allocated	Management of ESO internal deliverables

Table 4.9. Instrumentation work packages and managers for the construction phase.

* Contract and ESO deliverables work package pairs continue in this pattern for future instruments.

4.3.3 PRODUCT ASSURANCE AND SUCCESSFUL DELIVERY OF INSTRUMENTATION

The E-ELT will be the largest and most expensive optical-IR facility for ground-based astronomy ever built. Observing time will be highly competitive and highly valued. It is therefore important that new and higher levels of reliable performance and low downtime are achieved for the instruments. For this reason, lessons learned over the period of VLT instrument construction must be reviewed and used to devise best practice guidelines to be applied to E-ELT instrument construction.

A framework for product and quality assurance for the E-ELT is given by E-MAN-ESO-156-0139 issue 5 and this forms the basis for ESO interactions with industry; this will be partially applicable to instrument projects. However, the construction of instruments with consortia of Member State institutes also presents additional problems and advantages and to this end we will apply best practice based on lessons learned over the last ten years of instrument construction for the VLT/I. A particularly critical phase occurs in the project start-up period when the work breakdown structure is developed, work packages are allocated to institutes and the scientific and technical leadership team is defined. An experienced ESO Product Assurance (PA) team will be set up to work with the consortia in this phase. Both parties must be satisfied with the final project structure in order to proceed to a construction contract.

ESO will also be responsive to comments and suggestions from the community regarding improvements that should be made to ESO instrument construction working practices. Meetings will be arranged with senior managers from experienced institutes, in order to uncover areas of difficulty for the community and to generally improve internal ESO processes.

4.3.4 MILESTONES AND REVIEWS

Major project phases and review milestones will be explicitly indicated in the instrument agreements with consortia, and will be specified in each Statement of Work. The purpose of major reviews is to examine progress, recommend changes and advise on continuation of the instrument project to the next phase. Major review milestones will also be major payment milestones for consortia. In addition, in order to smooth cashflow, payments will also be made at other times based on agreed deliverables.

4.3.5 ESO AS CUSTOMER AND MEMBER OF A CONSORTIUM

ESO will take the role of active customer in all instrument projects. This means, in addition to the usual roles of monitoring progress and organising major milestone reviews, ESO will also keep a strong technical and managerial oversight team to comment in detail on design choices, interface requirements, and conformance with observatory standards. This approach has been developed following experience with the VLT instrument programme where it has become the standard model, welcomed by both ESO and instrument consortia. The effort for this managerial and technical oversight has been included in ESO instrument FTE (Full-Time Equivalent) planning.

It is expected that in many instrument projects ESO will also be responsible for delivering certain sub-systems, especially detectors and controllers. In these cases it is important that the relationship with the consortium is clear and follows good project management practice. ESO will therefore be a signatory to the consortium Memorandum of Understanding as an associate partner, and will participate in the project in the same way as any other institute — with a work package and deliverables, though without any GTO compensation. Tasks will include providing reports to the consortium project management, attending progress reviews and other work normally associated with a work package. Internally, ESO will keep work packages associated with this task separate from those of ESO as customer, and the two will be managed by different members of staff.

4.3.6 INSTRUMENT COSTS

100 M€ are available within the construction budget for the E-ELT for the capital costs of instrumentation and related subsystems including enabling technologies, and the staff costs at ESO. Community effort for instrument construction will be compensated by guaranteed time and is not accounted for in the instrumentation budget. The budget plan is based on the roadmap (Table 4.2). ELT-IFU and ELT-CAM are proposed as the first-light instruments and their costs are included within the plan along with the costs for the adaptive optics systems required to deliver the science cases for these instruments.

The estimated costs for individual instruments are based on those provided by the study consortia in the deliverable phase A documents describing the development and management plan. In preparing the E-ELT instrumentation plan, ESO has considered these predicted costs in the light of the expected technical changes during the development of specifications in 2012. The instrument costs include 20% contingency unless the phase A consortium suggested a higher contingency, in which case the higher figure is used. Research and development costs for individual instruments are included within the instrument work packages once the instruments are selected. Preparatory enabling technology developments, required before an instrument can be selected, are costed as a separate job, and will be funded and managed by ESO. They will be subject to revision as part of the process of reassessing the instrument requirements and further developing a detailed enabling technology plan.

The cost of the first four instruments in the roadmap will be accounted within the E-ELT construction proposal. Subsequent instruments will be resourced from Operations. This separation is purely for accounting purposes and there will not be any breaks or delays in the roadmap corresponding to this changeover, as shown in (Table 4.2).

The ESO experience with VLT first and second generation instruments is that large cost overruns (> 10%) for ESO have been rare. This is partly because ESO is protected against external staff effort overspends by the nature of our agreements with consortia. The agreements do not automatically compensate funding agencies in Member States if total staff effort used exceeds initial estimates. The funding of excess staff effort is therefore a problem that must in general be dealt with by the consortia and the funding agencies themselves. On the other hand, an excess in procurement spend does generally produce further financial support from ESO. This split in responsibility for overspends helps to spread the risk across all the stakeholders and partners.

4.3.7 EFFORT IN THE COMMUNITY AND AT ESO

The construction of the instrumentation for the E-ELT will overlap with a continuing and robust programme of instrumentation development for the La Silla Paranal Observatory (LPO). It is reasonable to ask therefore whether this would place undue strain on staff resources in Member State institutes. Figure 4.2 shows an effort model based on a plausible instrumentation plan for LPO, and the Instrument roadmap for E-ELT including technology development. It shows a reasonably constant effort profile with time. In fact in the years 2013–2017 the effort used should decrease slightly as second generation VLT instruments complete and E-ELT instruments are starting up. A significant factor is that although the total ESO spend on all instrumentation (VLT/I + E-ELT) will increase during E-ELT construction, a much greater fraction of the total E-ELT instrument cost is expected to go to industrial procurements rather than as staff effort in universities and institutes.

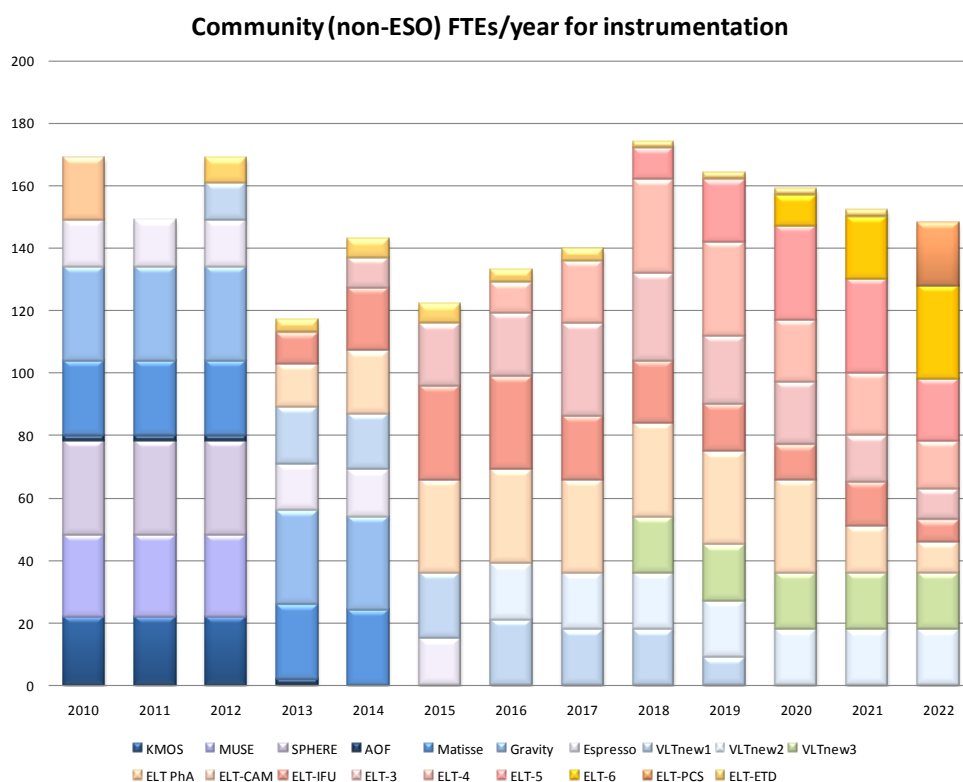

Figure 4.2. Community effort model.

ESO *internal* effort planning has also been done for the period 2012–22 and encompasses both the E-ELT instrument roadmap as presented here and a strong continuing LPO programme. Some difficulties with staffing occur in the years 2014–15, but overall the programme can be executed with existing Instrumentation Division and Directorate of Engineering staff. An important tool for ESO in managing the instrument programme is the ability to vary the mix of internal ESO/external-consortium/external industry work. If ESO is very stretched for effort we are able to outsource more. This has a cost impact of course in either GTO or cash, but does provide some flexibility to ensure progress during difficult periods.

4.4 APPENDIX: PHASE A STUDIES OF INSTRUMENTS AND ADAPTIVE OPTICS MODULES

4.4.1 A.1 INTRODUCTION

The phase A instrument studies were carried out with consortia of ESO and external institutes with the goal of addressing the observing capabilities of highest scientific priority for the telescope. The final reports included the most important science cases for which the instruments would be used, the technical concept for the instrument, the expected performance, cost, FTE effort and a construction schedule.

The studies are described briefly in the sections that follow. The post-focal AO modules are described first followed by the instrument studies in the order reviewed.

4.4.2 A.2 THE ATLAS POST-FOCAL LASER TOMOGRAPHY AO MODULE STUDY

ATLAS is a LTAO system providing atmospheric turbulence correction on a 30-inch diameter FoV in the wavelength range of the telescope. It complements the telescope GLAO by higher-order AO correction, giving a diffraction-limited Point Spread Function (PSF) down to the *H*-band, and offers great improvements in sky coverage over SCAO. The science FoV is free from any ATLAS optics making it particularly suited to instruments that prioritise high throughput or low emissivity over correction of a large field of view.

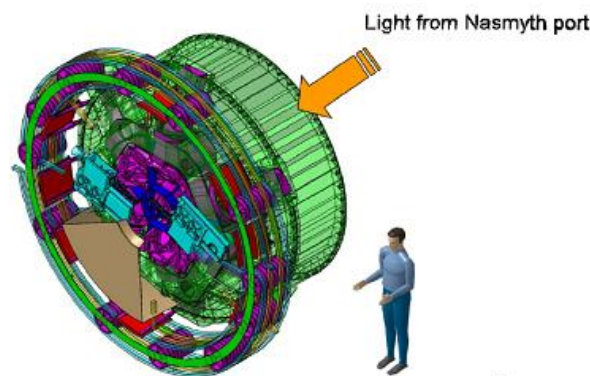

Figure 4.3. The ATLAS post-focal laser tomography AO module.

In the initial concept, ATLAS is a facility that may be duplicated for different Nasmyth ports in order to feed different “client” instruments. In the phase A study, the performance of ATLAS was considered to provide the following instruments with an AO-corrected beam: HARMONI, METIS and SIMPLE. The wavefront correction is made using the telescope adaptive mirror M4 and the wavefront sensing is assured by six laser guide star visible WFS and two natural guide stars infrared WFS. The six LGSs, mounted at a 4.3-arcminute diameter, are used to perform the tomography of the atmosphere above the telescope and therefore to overcome the focus anisoplanatism of a single laser beam on a 42-metre telescope. The two NGS WFS are required to measure the low-order mode perturbations not sensed by the LGSs. To maximise the sky coverage to close to 100%, the two IR NGS arms are equipped with local deformable mirrors providing an optimised additional atmospheric correction in the direction of the NGSs using the LGS tomographic measurements. This correction, combined with an innovative full aperture low-order focal plane sensor, maximises the sensitivity of the NGS WFS and therefore the NGS WFS signal-to-noise and NGS limiting magnitude. The low-order control performance benefits from an optimal control law (Kalman filter) to correct telescope windshake and low order modes. ATLAS is mounted on the telescope instrument rotator, has a cylindrical volume of 4000 mm × 1000 mm and weighs 1.5 tonnes.

Performance	SC (pole)
52% SR in K	92%
40% SR in K	96%
35% SR in K	97%
13% SR in K	100%

Lambda	900	125	165	220	480	10 500
EE in 10 mas	10.3	21.1	26.1	26.4	13.7	3.9
EE in 20 mas	15.1	32.1	42.5	48.5	37	14.3
EE in 40 mas	18.2	37.8	53.6	63.8	61.0	35.1
EE in 60 mas	22.4	40.5	56.3	67.8	69.1	54.2
EE in 80 mas	23.2	42.4	58.2	70.2	80.1	63.8
EE in 100 mas	25.6	44.8	59.5	71.7	84.6	67.5
Strehl ratio	5.5	18.8	35.3	52.7	90.5	96.9

Table 4.10. ATLAS sky coverage versus Strehl Ratio (SR) in K-band (left) and Ensquared Energy (EE) versus wavelength (right).

4.4.3 A.3 THE MAORY POST-FOCAL MULTI CONJUGATE AO MODULE STUDY

MAORY is a MCAO module providing three-dimensional atmospheric turbulence correction over a 2-arcminute diameter FoV in the wavelength range 0.8–2.4 μm . The correction is implemented by means of three deformable mirrors optically conjugated at different altitudes in the atmosphere. One of the three is the telescope M4, conjugated to the ground layer; the other two deformable mirrors are located in the MAORY instrument and conjugated to 4 km and 12.7 km. The wavefront sensing is assured by six LGS WFS and three NGS infrared WFS. The important properties of the delivered optical beam are near-diffraction-limited correction and a consistent PSF delivered over a substantially wider field of view than with LTAO or SCAO techniques. For the phase A study, a design for MAORY was explored in which the corrected beam could be directed to one of two output ports and so could supply two science instruments. The beam relayed by MAORY has the same focal ratio and exit pupil position as the beam from the telescope.

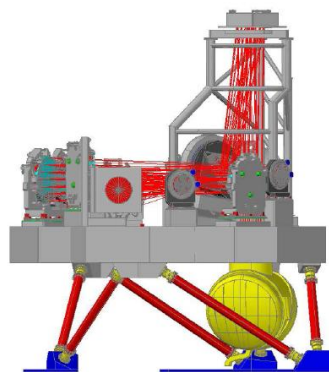

Figure 4.4. The MAORY post-focal multi-conjugate AO module.

The mechanical layout above shows that the red beam is directed from the optics tower into an upward-looking instrument. An instrument of up to 5 tonnes can be mounted on the rotator provided by MAORY in this gravity-invariant location. The second port would feed a free-standing instrument with higher mass limits. In the phase A study, the performance of MAORY was considered for two client instruments — MICADO and SIMPLE. An important driver on the MAORY design is the science requirement from MICADO for astrometric accuracy of 50–100 mas, which was demonstrated to be met. The volume of the instrument is $L \times W \times H = 7400 \text{ mm} \times 7200 \text{ mm} \times 8000 \text{ mm}$ and it weighs 12.7 tonnes. The review of the phase A design concluded that there were possibilities for some simplification of the optical design. Reducing to one, rather than two, optical relays is thought feasible and would reduce the number

and size of large optical components and therefore the cost and risk of the module. The evaluation of the performance when including only a single DM will also be revisited during the specification development phase. Finally, if the spectroscopic mode were to be included in the camera, the scientific impact on sensitivity of the warm AO system would have to be evaluated, traded against the technical impact of cooling this large system.

Minimum Strehl ratio averaged over MICADO field of view (53 arcseconds × 53 arcseconds)			Sky coverage
$\lambda = 2.16 \mu\text{m}$	$\lambda = 1.215 \mu\text{m}$	$\lambda = 0.9 \mu\text{m}$	
0.54	0.14	0.03	39%
0.52	0.13	0.03	50%
0.50	0.11	0.02	60%
0.48	0.09	< 0.01	70%
0.42	0.06	< 0.01	80%

Table 4.11. Sky coverage vs. performance at the Galactic pole for seeing of 0.8-arcsecond FWHM (Full Width at Half Maximum).

Ensquared energy 50 mas × 50 mas					
FoV position (arcseconds)	$\lambda = 2.16 \mu\text{m}$	$\lambda = 1.65 \mu\text{m}$	$\lambda = 1.215 \mu\text{m}$	$\lambda = 1.021 \mu\text{m}$	$\lambda = 0.9 \mu\text{m}$
0	0.53	0.37	0.19	0.12	0.10
30	0.49	0.33	0.15	0.10	0.08
60	0.41	0.24	0.10	0.07	0.07

Table 4.12. Ensquared energy in a square aperture of 50 mas × 50 mas averaged at three radial distances from the centre of the field for seeing of 0.8-arcsecond FWHM.

4.4.4 A.4 THE CODEX INSTRUMENT STUDY

CODEX is a high stability, high resolution ($R \sim 130\,000$) optical spectrograph optimised for the wavelength range (0.37–0.71 μm) which has the goal of achieving a Doppler precision of 2 cms^{-1} over a 30-year timescale to meet the science goals of the instrument. The CODEX science team developed in detail the case for a direct measurement of the accelerating expansion of the Universe, and the instrument was designed to explicitly address this top science case for the E-ELT. By the same token (ultra-stable radial velocity measurements), Earth twins in the habitable zone around solar-type stars become detectable, demonstrating that the E-ELT will, in several respects, address exquisitely this hottest of science fields. Both cases figured prominently amongst the DRM cases. An additional case showed that the E-ELT, equipped with a high-resolution spectrograph, would enable a significant advance in the field of nucleochronometry, i.e., galactic archaeology. The fourth showcase of the team was the exploration of the intergalactic medium. By analysing the line-of-sight towards distant quasars, intervening absorption systems can be analysed and not only the structure, but also the element enrichment of the Universe understood out to the earliest epochs. Last but not least, the CODEX science proposed to test fundamental physics by taking the test of the stability of fundamental constants to new limits: a precise measurements of atomic transitions back 90% of the age of the Universe allows a precise test of whether our physical laws have varied, even only slightly, since early times, opening a whole new perspective in physics.

The CODEX design draws heavily on the scientific and technical experience with the HARPS spectrograph, particularly in consideration of the steps required to control the radial velocity error budget. The natural location for the instrument is in the coudé room of the E-ELT where it will be housed in a temperature stable environment. It is a single object spectrometer (0.82-arcsecond aperture) requiring no adaptive optics, although image stabilisation in the coudé train may be necessary to maintain the required image quality. A laser frequency comb will provide stable, simultaneous wavelength calibration over long timescales. The input to the spectrograph is a single large fibre for the object and a second for the calibration source or sky. A highly anamorphic pupil ($\times 12$) is formed and sliced into six slices which are fed

into the spectrograph by a three-mirror anastigmat used in double-pass. The echelle grating is based on that in UVES and is a mosaic of four 408 mm × 200 mm R4 gratings. After the grating, the beam is split to feed blue and red cameras for optimal efficiency and to allow a stable spectrometer format with no moving parts in the instrument. Cross-dispersion is achieved using slanted VPH gratings that are being tested in prototype. The resulting spectrum has $R \sim 120\,000$ with four-pixel sampling, an order height of ≥ 170 pixels and separation of ≥ 30 pixels. The focal plane will have $9\text{k} \times 9\text{k}$ $10\ \mu\text{m}$ pixels.

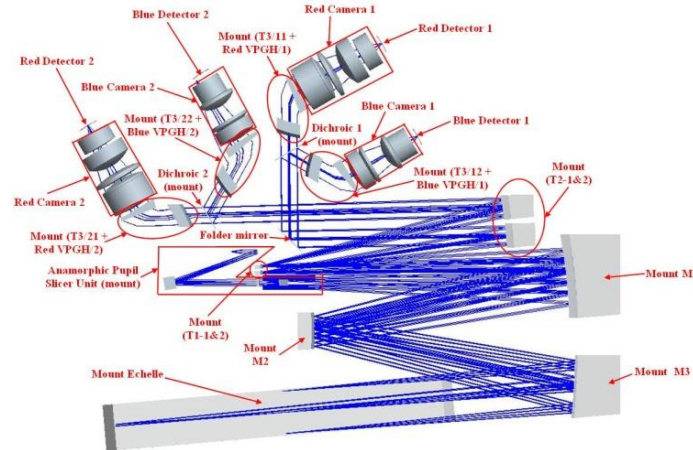

Figure 4.5. The optomechanical concept of the CODEX spectrograph.

4.4.5 A.5 THE EAGLE INSTRUMENT STUDY

EAGLE is a multi-IFU spectrometer for the NIR wavelength range that uses an on-instrument MOAO system. The EAGLE science case focuses on the study of high-redshift galaxies. Such an instrument on the E-ELT will enable surveys of the earliest (and rapidly growing) galaxies. The goal is to exploit the spatial resolution of the E-ELT to understand the star formation history during the epoch of growth of structure and assembly of galaxies. Pushing the E-ELT to its limit, EAGLE would enable the spectra of the very first galaxies to be obtained at redshifts 8–10, close to the epoch of reionisation of the Universe and providing unprecedented insight into this epoch. Integral-field spectroscopy of galaxies with active galactic nuclei will be possible from nearby to significant lookback times and will allow us to better understand the link between the growth of the central massive black hole and the bulge of the galaxy. Closer to us, it will be possible to obtain spectra of individual stars in nearby galaxies, for the first time beyond the Local Group of galaxies, allowing both detailed chemical and kinematic studies, critical for the understanding of galaxy evolution. EAGLE would also be able to address some of the most prominent questions in our own Galaxy. It would allow a detailed study of the gas and stars in the inner parsec of the supermassive black hole at the centre of the Milky Way, helping to uncover its formation and growth history as well as providing new insights into star formation in the very inner regions of the Galaxy.

Key to the scientific performance of EAGLE is the MOAO system that delivers the required image quality in the direction of the sources to be observed by sensing and reconstructing the atmosphere above the telescope using 6 LGS WFS and 5–6 NGS WFS. The correction required at the field position of the object to be observed is calculated and the correction for the atmosphere is applied by a combination of the telescope M4 and the 84×84 actuator deformable mirrors in the optical path to the spectrometers. The selection of this AO concept was tied closely to the science case for the instrument. EAGLE MOAO achieves a sky coverage above 80% for $R < 17$ stars and delivers moderately high encircled energy in pixels suited to the size scales of the high-redshift EAGLE targets (requirement: $> 30\%$ EE in 75 mas). EAGLE was studied for the preferred location at the $f/18.85$ Gravity Invariant Focus (GIF) of the telescope. To meet the science requirement on field size, the full 10-arcminute field of the telescope is directed to the GIF by a large M6. A consequence of this is that the pre-focal station guide probes are vignetted by M6 and so EAGLE must reproduce the signals required to control M4 and M5 with the instrument wavefront sensors. This functionality is designed into the EAGLE adaptive optics system. The selection of the clustered objects is via pick-off mirrors that are placed robotically in the focal plane. The light from each of the 16–20 sources is then directed towards the spectrograph via an optical system for path difference compensation (due to field position) and a deformable mirror controlled by the MOAO

system. The beams from two targets are combined in one glass image-slicing IFU. In total, there are 8-10 spectrometers based on VPH gratings, each with a $4k \times 4k$ detector array, providing low ($R \sim 4000$) and high ($R \sim 10\,000$) spectral resolving power. EAGLE is partly cryogenic — the pick-off and AO systems are at room temperature, whereas the spectrographs are cooled with liquid nitrogen to 190 K. For a future instrument based on the EAGLE concept, substantial revision of the design and significant prototyping are required. Removal of the gravity-invariant focus means that a delta phase A study will be needed to find a new concept for delivering the EAGLE science case and performance on the Nasmyth platform.

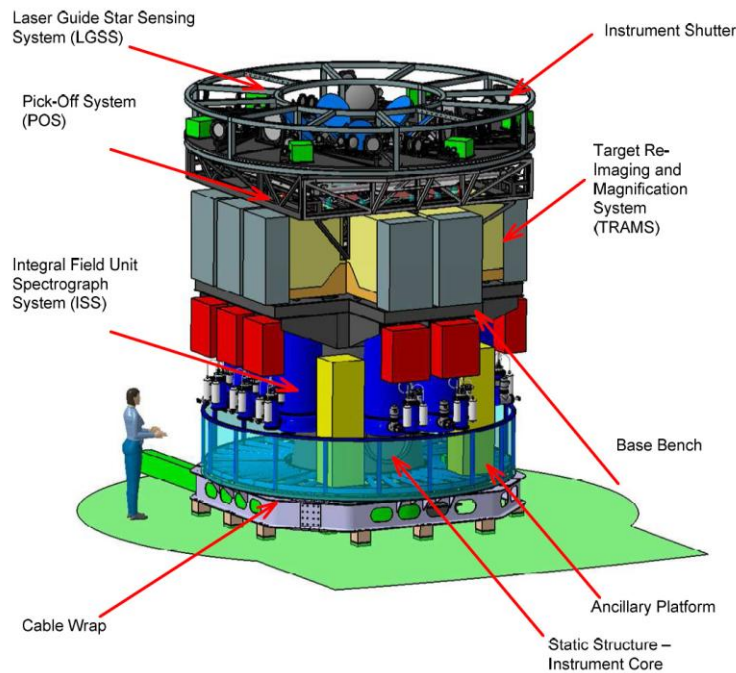

Figure 4.6. The architecture of the EAGLE instrument. Light is directed into the top of the instrument as shown. The whole system is mounted on a mechanical rotator.

4.4.6 A.6 THE EPICS INSTRUMENT STUDY

The EPICS instrument is essentially designed to image exoplanets directly, one of the ultimate goals of the E-ELT. The EPICS science team explored several science cases around this topic and answered in detail what will be possible with the E-ELT. Young, self-luminous planets in star-forming regions or young clusters will be prominent targets as they can be imaged all the way into the solar system near the snow-line, and this out to the distance of the nearest star-forming regions (300–500 light-years). At closer distances (< 30 light-years from the Sun) an instrument such as EPICS on the E-ELT will be able to image mature planets of the mass of Neptune or a super-Earth, potentially in the habitable zone of their star. A first characterisation with low-resolution spectroscopy of their atmospheres will be possible and O_2 -dominated atmospheres (signs of life?) will be detectable. In an interplay with other instruments detecting planets by radial velocity or in the mid-infrared, EPICS will be able to follow up and image the most interesting candidates directly. The combination of instruments on the E-ELT will allow a first characterisation for many planets and thus strongly support the development of planet formation theories.

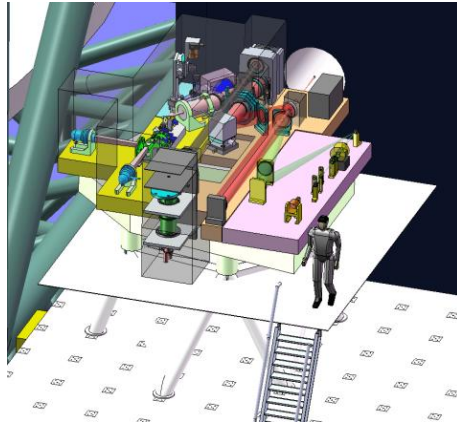

Figure 4.7. A schematic overview of the major components of EPICS mounted on the Nasmyth platform.

The EPICS concept combines extreme adaptive optics with the capabilities of two (possibly three) science instruments to achieve these goals. Contrast ratios of 10^{-8} – 10^{-9} are required and are reached using a combination of innovative optical design, extremely high Strehl AO ($> 90\%$) and differential detection methods including polarimetric imaging and integral field spectroscopy. The final step in achieving these contrasts is in the data reduction and post-processing. EPICS is a bench-mounted instrument that can be located on the Nasmyth platform; the preferred location is the straight-through port. 10% of the light is used by an on-instrument SCAO system that provides signals for the telescope M4. The common optical path contains an atmospheric dispersion corrector and the high-order deformable mirror for the XAO module. The science beam may be directed into either the integral field spectrograph or the EPOL imaging polarimeter. The baseline for the integral field unit is a lenslet design based on the SPHERE design; there are 343×343 lenslets for a 0.8-arcsecond field. An alternative image-slicing design remains under study. The spectrometer optical design has a six-lens collimator and five-lens camera which focuses the light on a mosaic of four $4k \times 4k$ detectors. The only cryogenic element is the detector since the wavelength range is restricted to 0.6–1.65 μm . The EPOL field is 1.37 arcseconds \times 1.37 arcseconds; each channel is equipped with a $4k \times 8k$ CCD. A third science instrument — a differential speckle imager — is also part on the continuing work on conceptual design and prototyping. The XAO system uses an innovative roof-pyramid wavefront sensor to measure the signals to control a 210×210 actuator deformable mirror of ~ 300 mm diameter.

4.4.7 A.7 THE HARMONI INSTRUMENT STUDY

HARMONI is an integral field spectrometer covering a broad wavelength range (0.47–2.45 μm) designed for operation with the LTAO system. It is a multimode instrument covering a wide range of observational conditions and scientific programmes. The HARMONI team highlighted the E-ELT strong science cases that high spatial resolution, integral-field spectroscopy will enable. One of the most interesting cases is the one complementing the exoplanet cases of other instruments, with the possibility to obtain spectroscopy of the typical Jupiter-mass exoplanets detected with 8–10-metre-class telescopes. This will allow researchers to fully characterise this type of exoplanet by determining their age, mass and temperature. By expanding this case to higher mass, it will be possible to study the low-mass regime of star formation and to understand the transition between planet and brown dwarf formation. Further, the high spatial resolution of the instrument will probe the vicinity of intermediate-mass black holes in star clusters and dwarf galaxies, thought to be possible seeds of supermassive black holes at high redshift. The combination of high spatial and medium to high spectral resolution will further allow the study of resolved stellar populations in nearby galaxies with the goal of better understanding galaxy evolution throughout cosmic time.

Similarly, HARMONI complements the science cases outlined by the EAGLE science team with higher spatial resolution for single objects and with extension to the visible wavelength range. The scientific case for HARMONI calls for three spectral resolution modes ($R \sim 4000$, $R \sim 10\,000$ and $R \sim 20\,000$). Four selectable plate scales (4 mas, 10 mas, 20 mas and 40 mas) are matched to the size scale of the astronomical objects to be studied with the resulting field size (5 arcseconds \times 10 arcseconds, 2.5 arcseconds \times 5 arcseconds, 1.25 arcseconds \times 2.5 arcseconds, 0.5 arcseconds \times 1.0 arcsecond

respectively) being derived from consideration of the source sizes, the expected PSF (whether seeing-limited or delivered by an AO system) and the demands of obtaining good sky subtraction in the near-infrared. To achieve the large fields with fine sampling, HARMONI partitions the input focal plane into four subfields that feed four integral field units. The output of the IFU is two pseudo-slits that form the input to two spectrographs. Thus for the full field, there are eight spectrographs in total. VPH gratings are the baseline for this component — ten gratings are mounted in a wheel for the NIR. The detector is a $4k \times 4k$ NIR detector. For optical spectroscopy ($0.47\text{--}0.8 \mu\text{m}$) the expected performance of the AO at this wavelength implies that the 40-mas pixel scale is adequate in all cases. Since there is no need for rapid beam-switching for sky subtraction, one quarter of the field is sufficient ($5.0 \text{ arcseconds} \times 2.5 \text{ arcseconds}$). Therefore, one of the IFU channels is equipped with two optical spectrographs and wheels containing five VPH gratings to cover the visible wavelength range; the detector is a $4k \times 4k$ CCD. To reduce the thermal background, the complete optical train for HARMONI is liquid nitrogen cooled and contained in a 4-metre diameter cryostat mounted statically on the Nasmyth platform. The field rotation for the small input field is compensated by an optical de-rotator in the instrument fore-optics. A secondary guiding system, also in the common fore-optics, corrects for any relative motions of HARMONI and the telescope beam using measurements of a natural guide star selected within a 19-inch beam. HARMONI is designed for use with the LTAO system and with GLAO. A SCAO system using the telescope M4 has been designed and could be built to substitute for the LTAO system, though with limited sky coverage, in the case that HARMONI were to be developed on a shorter timescale than the LTAO.

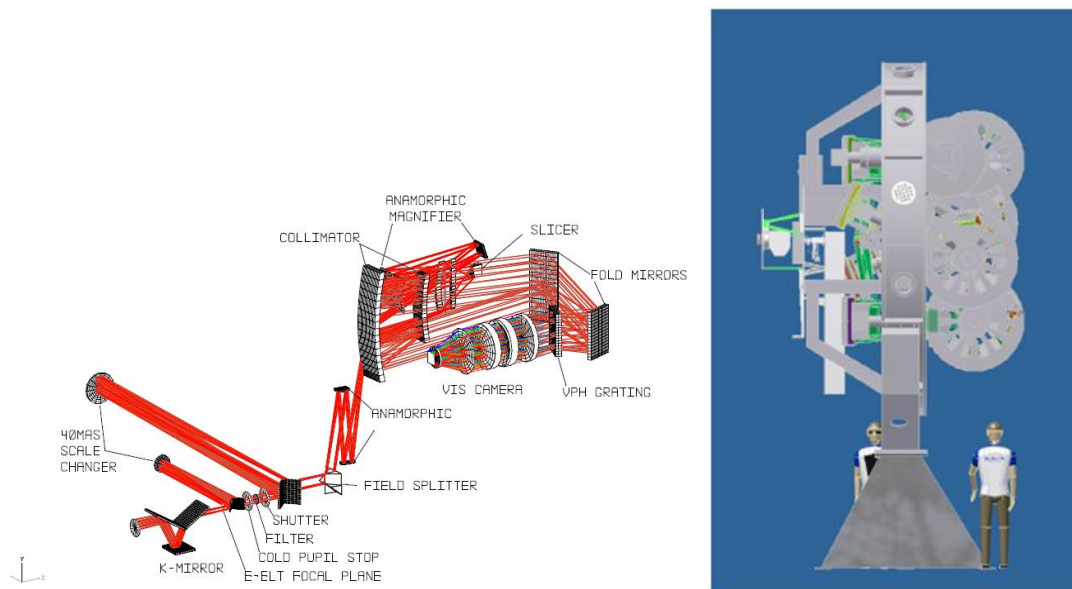

Figure 4.8. The optical path of a single channel from the K-mirror that de-rotates the field to the detector. This is for one of the two visible cameras. Light from the telescope passes through the scale changer in the fore-optics, then is subdivided at the field splitter. The beam is collimated before entering the slicer and finally focused onto the spectrometer $4k \times 4k$ array.

The main risk to technical readiness of the instrument is the complexity resulting from the size of the cryostat and the number of mechanisms. To deliver HARMONI as a first-light instrument, careful consideration will be given to simplifying the optomechanical concept while maintaining the key scientific drivers that include the operation at visible wavelengths and the high spectral resolution spectroscopy. The possibilities include reducing the number of spectrographs to reduce volume and mass of the instrument. This may be achieved by a revision of the optical design or by reducing the field of view. The latter would affect the sky-subtraction scheme currently planned for the instrument (nodding along the IFU) with the potential to limit the sensitivity ultimately achieved. Further work with SINFONI data and experience with KMOS (to be commissioned in 2012) will improve our understanding of NIR sky-subtraction with IFUs. Further work is required regarding the strategy for implementation of the adaptive optics module. During the phase A studies, it was not possible to investigate the full integration of the instrument with the AO module. This may result in substantial simplifications of the AO module design and alleviate one of the

risks to performance identified during the design phase, namely that there would be differential flexure between the instrument and the AO module.

4.4.8 A.8 THE METIS INSTRUMENT STUDY

METIS is a workhorse instrument for the thermal infrared (2.9–14 μm) region offering nine different observing modes - imaging in the *LM*- and *N*-bands, long-slit spectroscopy with moderate resolving power ($R \sim 5000$) for the *LM*- and *N*-bands; integral field spectroscopy at high resolving power ($R \sim 100\,000$) in the *LM*-bands; coronagraphy and polarimetry. The METIS science team analysed the breakthrough science in the mid-infrared that will become possible with the E-ELT. The E-ELT with an MIR capability will excel in protoplanetary disc research, probing inside 1–10 AU of forming exoplanetary systems and understanding their origin and diversity. Furthermore, the MIR is the wavelength of choice to image young, self-luminous giant planets and to study the molecules present in their atmospheres as well as their weather. METIS on the E-ELT will characterise a large number of young exoplanets. With its very high spectral resolution in the mid-infrared, METIS will also allow the study of the Solar System in more detail than ever before, from cometary volatiles to the surface of Kuiper Belt objects. METIS promises a strong push in our understanding of stars and planets, but its science cases are not limited to the local Universe. Indeed, MIR wavelengths can penetrate the heavily obscured inner regions of nearby galaxies and offer a unique opportunity to study the interplay of heavy star formation and active galactic nuclei, and ultimately between the supermassive black hole and the surrounding interstellar medium.

On entering the METIS cryostat, light from the telescope is split, with the visible light sent to the wavefront sensor for the instrument SCAO mode that sends correction signals to the telescope M4/M5. The infrared beam then passes through a Dicke switch which acts as an internal, fast chopper, through the optical de-rotator and then may be directed into the modules containing the high-resolution spectrograph, the *LM*-imaging plus low-resolution spectroscopy or the *N*-band imaging plus low-resolution spectroscopy. The fast chopper is a novel concept for this instrument: chopping is more usually achieved with a telescope secondary mirror — a possibility not open to the E-ELT due to the size of the M2. The whole optomechanical system is at a temperature of 80 K, with the exception of the *N*-band spectrograph which is cooled to 30 K. The METIS detector system is based on the Aquarius MIR detectors currently being implemented for VISIR on the VLT. As mentioned above, METIS is equipped with an on-instrument SCAO system. An interesting outcome from the study was that diffraction-limited image quality in the MIR can be delivered using just the telescope M4, with wavefront correction signals provided from an on-board SCAO system. The full science performance is met when METIS is coupled with the ATLAS LTAO system offering high sky coverage.

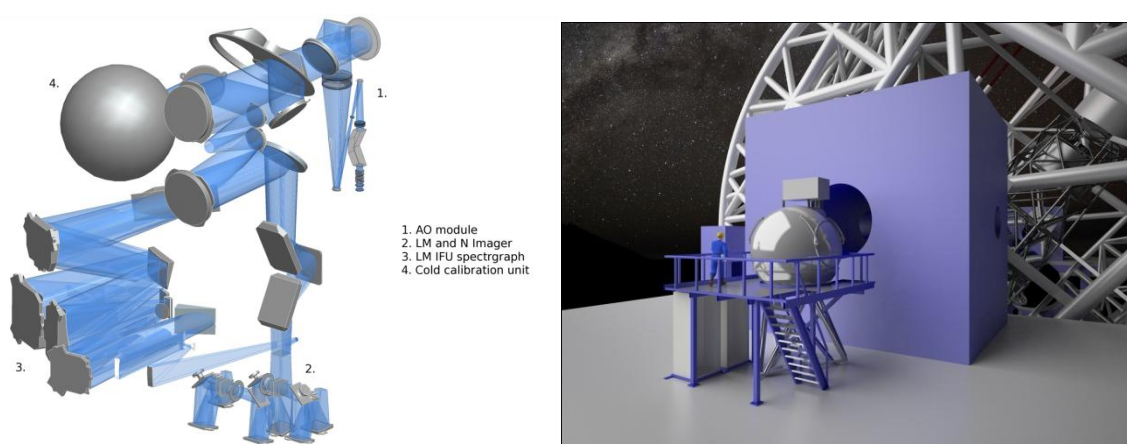

Figure 4.9. The optical layout of METIS (left) showing the two science modules — the imager with low-resolution spectroscopy and the high-resolution spectrometer. The on-board AO module is shown. This complete system is inside the METIS cryostat shown (right) at the straight through port on the Nasmyth platform.

4.4.9 A.9 THE MICADO INSTRUMENT STUDY

MICADO is an infrared (0.8–2.5 μm) camera designed to exploit the diffraction limit of the telescope. The MICADO science team studied the science case for such an instrument and drew attention to astrometric science cases. With a diffraction limit of 5 milliarcseconds at 1 μm wavelength, astrometry at the 100 to 50 microarcsecond level becomes possible. This, in turn, opens a new parameter space that can be exploited for many exciting science cases.

Two of the most prominent examples are: the kinematics of stars only ~ 100 Schwarzschild radii from the supermassive black hole in the centre of the Milky Way, orbiting the black hole with orbital velocities of $0.1c$ (c : speed of light), allowing the detection of the effects of special and general relativity. The other example is the kinematics of star and globular clusters in our Milky Way as well as of dwarf galaxies in the Local Group, offering a whole new understanding of dynamical effects from intermediate-mass black holes to dark matter halos. Beyond astrometry, MICADO is designed to obtain exquisite photometry of dense, resolved stellar populations at the highest possible spatial resolution. From the science team's studies, it is clear that useful colour–magnitude diagrams will be obtained out to distances unachievable today, complementing the spectroscopy of individual stars and allowing the disentangling of the multiple stellar populations in many nearby early- and late-type galaxies. What is today often referred to as near-field cosmology (a detailed history of the star formation history of the Universe) will get a totally new meaning with the E-ELT.

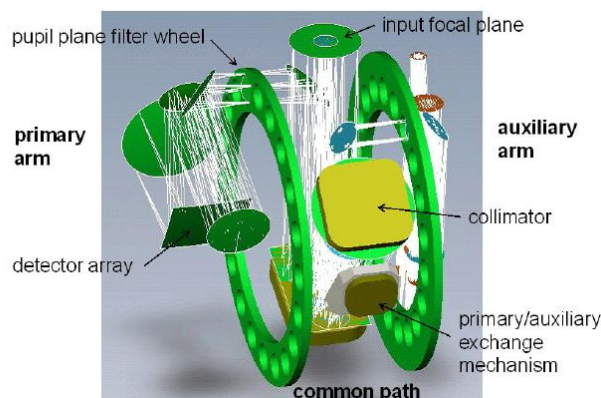

Figure 4.10. The two arms of the MICADO instrument — the primary arm with the 53 arcseconds \times 53 arcseconds camera and 16-detector focal plane; the auxiliary arm with the additional scientific modes including spectroscopy, higher resolution imaging at 1.5 mas per pixel and options include high time-resolution imaging, polarimetry. A simple fold mirror is used to select between them.

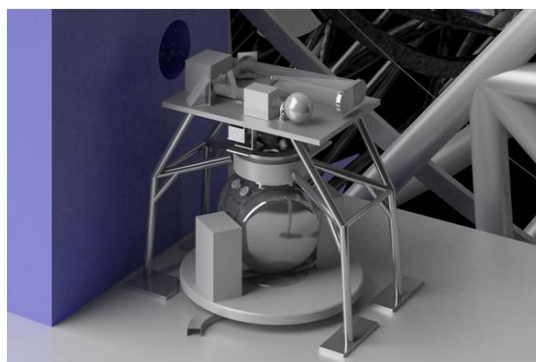

Figure 4.11. MICADO mounted on the Nasmyth platform under the SCAO module that is proposed by the team as an interim measure until the LTAO system is complete. The interface is identical. MICADO operates in this gravity-invariant location, rotated by a mechanical rotator on the Nasmyth platform.

The optomechanical concept is for an instrument with two separate optical paths. The main or primary arm of the instrument contains a fixed-plate scale camera; the optical design is a three-mirror anastig-

mat. A key goal for the instrument is to deliver astrometric accuracy of 50 μs and so the primary arm has fixed optics with the only mechanism being a filter wheel providing a selection of 20 filters. The field of view of this arm is 53 arcseconds \times 53 arcseconds with 3-mas sampling (Nyquist sampling the diffraction limit at 1.0 μm). The focal plane is an array of sixteen 4k \times 4k NIR detectors. The whole instrument is designed to operate in a gravity-invariant location with the telescope beam folded into the upward looking cryostat. An auxiliary arm in the instrument is selected by a fold mirror and provides additional scientific capabilities, including long-slit spectroscopy, polarimetry, a small field with finer pixel scale for astrometry in crowded fields (1.5 mas pixels) and possibly a high time resolution mode. The science case for MICADO demands the moderately wide field with uniform PSF that can be delivered by a multi-conjugate adaptive optics system.

In the conceptual phase, MAORY was considered to feed MICADO. Since the MAORY schedule predicted at phase A is longer than that for MICADO, a SCAO module was included in the MICADO baseline design in the later stages of the study. This delivers high Strehl images ($> 70\%$ on-axis at $m_v = 12$) and a 27 arcseconds \times 27 arcseconds corrected field, of course to be restricted to fields with a bright guide star. A phased delivery of the detectors was proposed by the consortium as an option for matching a phased AO delivery while assisting with the project costs/cash flow.

4.4.10 A.10 THE OPTIMOS–DIORAMAS INSTRUMENT STUDY

OPTIMOS–DIORAMAS is an imager and slit mask-based multi-object spectrometer for the wavelength range 0.37–1.4 μm . The OPTIMOS–DIORAMAS team concentrated their efforts on studying the high-redshift galaxy survey and characterisation capability of the E-ELT. Multi-slit instruments such as the one proposed are very powerful in exploring from redshifts 1 to 6 essentially the entire period of galaxy formation and evolution. The OPTIMOS–DIORAMAS team proposes an ultra-deep imaging survey (down to AB magnitudes of 30, an order of magnitude deeper than possible today). A complementary spectroscopic survey would discover the first building blocks of galaxies at redshifts $z > 6$ and trace the mass assembly of galaxies since this earliest epoch of galaxy formation. The oldest stellar populations, expected in quiescent galaxies, can be traced well beyond a redshift of $z \sim 2$ with the E-ELT — and so can the population and frequency of galaxies with active galactic nuclei. Finally, 3D tomography of the intergalactic medium at $2 < z < 3.5$ can be studied through quasar absorption lines and the large-scale distribution of galaxies at redshifts $z > 2$. In summary, the E-ELT will be able to explore the formation of galaxies and the large-scale structures in the Universe in an unprecedented way.

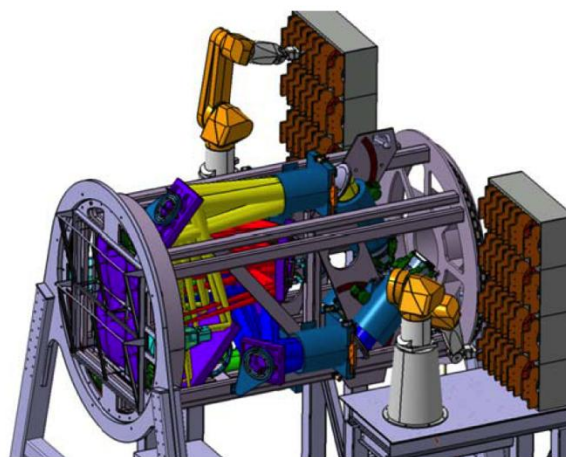

Figure 4.12. A view of the OPTIMOS–DIORAMAS system with the cabinets for the filters and gratings and robotic exchange mechanisms (to the right). At the left of the figure, the mask exchange mechanism can be seen. The cylindrical structure is the rotating part of the instrument.

The realisation of this wide-field MOS is as follows. A 6.78 arcminute \times 6.78 arcminute field is split into four quadrants at the telescope focal plane and feeds four spectrometers — two optimised for the wavelength range 0.37–1.0 μm using three 4k \times 4k CCD detectors and two optimised for the range 0.6–1.4 μm using three 4k \times 4k HgCdTe detectors. In the overlap wavelength range (0.6–1.0 μm),

OPTIMOS–DIORAMAS can survey a field of 44 arcmin²; outside this range the field is 22 arcmin². The design is optimised for high-redshift science and, in particular, redshift surveys.

An ultra-deep imaging survey is a goal of the science case. For spectroscopy, the multiplex may be as high as 480 in the optical and with the lowest spectral resolution ($R \sim 300$); in the NIR, a multiplex gain of 160 is foreseen ($R \sim 3000$). The 0.8 mm thick steel slit masks are 780 mm × 780 mm, weigh 3 kg and are laser-cut on site. The baseline slit width of 0.5 arcseconds is designed to exploit the performance of the LGS GLAO system although the instrument can be used in seeing-limited conditions with some slit losses or some reduction in resolving power. At the detector, the slit width is sampled by ten pixels. The use of an atmospheric dispersion compensator is not essential if the zenith angle of operation of the instrument is restricted. The spectrographs and focal plane are part of the rotating structure of the instrument, relying on active flexure compensation. A novel aspect of the DIORAMAS design is the use of a robotic arm to exchange the filters for imaging or the gratings for spectroscopy, thus removing the need for large gratings wheels. A mixture of transmission gratings and VPHs are used. The instrument has a mass of 24 tonnes in a volume 6 m × 6 m × 6.5 m.

The long wavelength cut-off of the instrument (either 1.4 μm or 1.6 μm) must be decided during the specification development phase. The gain in performance in extending to 1.4 μm is minimal given the atmospheric window between the *J*- and *H*-bands; however extending to 1.6 μm would have implications for the thermal background, possibly requiring the cooling of substantial sections of the instrument. This issue was not addressed during the study and it could substantially affect the mechanical design. The DIORAMAS instrument concept uses a novel robotic filter/grating exchange arm that should be tested in prototype before finalising the instrument concept.

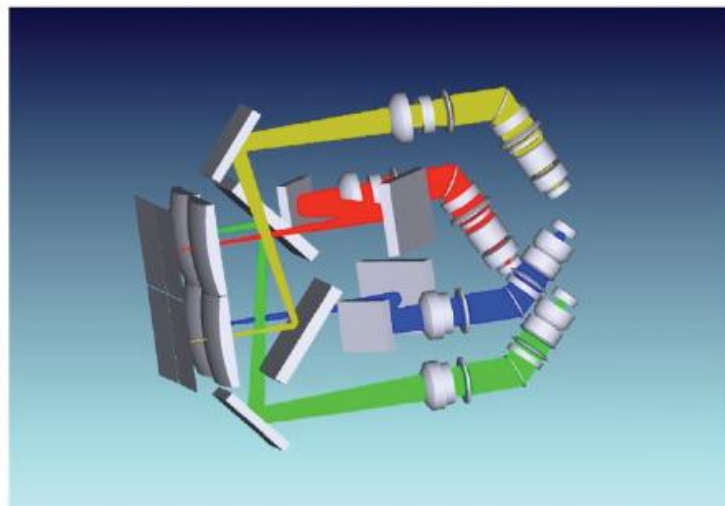

Figure 4.13. The optical layout of OPTIMOS–DIORAMAS in spectroscopic mode showing the four optical paths that make up the instrument — two optimised for the 0.6–1.4 μm range and two for the 0.37–1.0 μm range.

4.4.11 A.11 THE OPTIMOS–EVE INSTRUMENT STUDY

OPTIMOS–EVE is a fibre-based optical to NIR *H*-band multi-object spectrometer designed for operation in seeing-limited conditions, with the telescope NGS or LGS GLAO systems in operation. The instrument exploits the maximum field offered by the E-ELT, which is 10 arcminutes in diameter. The OPTIMOS–EVE science team collected a number of high profile science cases for a multi-fibre optical–NIR spectrograph. With such an instrument, it will become possible to search for exoplanets out to our nearest dwarf galaxy neighbours at the same level as they are found today with 8–10-metre-class telescope in the solar neighbourhood. As in the near-field cosmology cases described above, spectroscopy of individual stars in nearby galaxies can be extended to optical wavelengths and thus the detailed star formation histories traced. With respect to the distant Universe, the instrument is set up to track the first star-forming galaxies and sources of re-ionisation of the Universe at redshifts from 5 to 13. The integral field properties of such a spectrograph would be ideal to detect ionised gas around distant galaxies, complementing the neutral gas studies performed with ALMA. Finally, the high spectral resolution would allow a precise

tomography of the intergalactic medium at high redshifts, to e.g., probe the matter distribution and the geometry of the Universe.

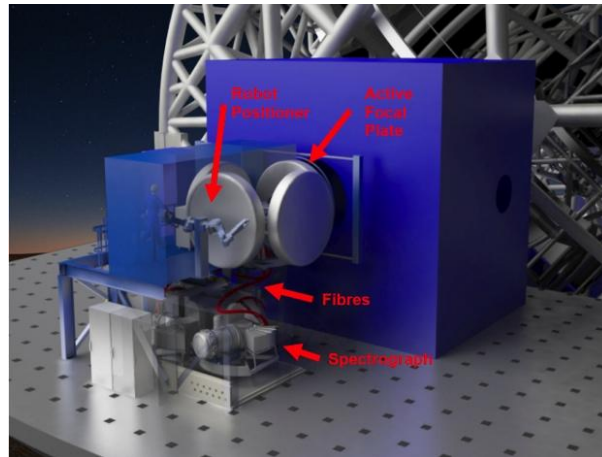

Figure 4.14. A schematic showing OPTIMOS-EVE on the Nasmyth platform, straight-through port. The spectrograph optical elements are mounted below the focal plates and the exchange mechanism.

Fibres are robotically placed onto one of four focal plane plates while a different field is observed. During an observation, the plate in use is mechanically rotated to track the field. OPTIMOS-EVE offers a multiplex of up to 240 for single objects, when observing with spectral resolving power $R \sim 5000$; for higher spectral resolving power modes 15 000 and 30 000 the multiplex is 70 and 40 respectively. In addition to the single-object mode, 30 fibre-bundle IFUs, each with a field of view of 1.8 arcseconds \times 3 arcseconds and one large IFU with field of view 7.8 arcseconds \times 13.5 arcseconds, are available for use with the lower spectral resolution mode. The fibres are split between the two spectrometers optimised for the optical and two optimised for the infrared. This allows simultaneous observations across the full wavelength range, the operational aspects of which are to be further explored as the instrument design progresses.

In the infrared, each spectrometer uses three 4k \times 4k detectors for the full multiplex and spectral resolution, with the possibility of a future upgrade to nine detectors for increased wavelength coverage. The optical spectrographs contain four 6k \times 6k CCD detectors. The spectrometers have large reflective collimators, refractive cameras and use VPH gratings for the dispersing elements. A total of ten gratings are required to cover the full wavelength range and all spectral resolving powers. Most of the OPTIMOS-EVE optomechanical system is operated at a temperature of 193 K in a cold chamber located in the platform under the focal plate system. As with OPTIMOS-DIORAMAS, an ADC is not necessary for OPTIMOS-EVE provided that only a restricted range of zenith angles is used. The accuracy of sky subtraction with the fibres is expected to provide the ultimate limit to the sensitivity for this instrument and is an area that would benefit from further study.

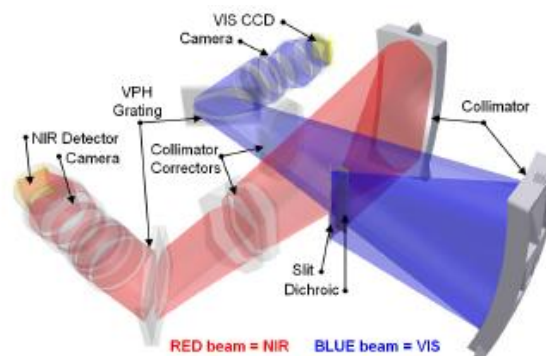

Figure 4.15. The optics of OPTIMOS-EVE showing the split of the infrared and optical light into the two optimised cameras. The beam is folded by the VPH grating.

4.4.12 A.12 THE SIMPLE INSTRUMENT STUDY

The SIMPLE science team looked into the breakthrough science enabled by a very high spectral resolution ($R \sim 100\,000$) NIR spectrograph. The most exciting case is certainly the possibility, with SIMPLE on the E-ELT, to obtain detailed spectroscopy of the atmospheres of exoplanets observed in transit in front of their star. Around low-mass stars, with planets on short orbits, it will be possible to identify and chemically characterise the atmospheres not only of Jupiters, but also of ocean planets of Neptune mass, or even rocky super-Earths. Ultimately, this might be the first chance to detect biomarkers (e.g., O_2) in exoplanet atmospheres.

The combination of enormous light-collecting power, high spatial (adaptive optics assisted) resolution and very high spectral resolution opens up a much larger parameter space to be explored. An instrument such as SIMPLE will also enable fantastic progress in the precise chemical characterisation of cool main sequence stars in the inner Galaxy or of star clusters out to the distance of the nearest galaxy groups and clusters. Absorption systems along the line of sight of quasars will be traced to $z > 4$, where metal lines can be used to explore the chemical pollution of the first stars (so-called Pop III).

The SIMPLE instrument concept is a fixed-format cross-dispersed échelle spectrometer delivering complete coverage from 0.84–2.45 μm in a single exposure with spectral resolution $R = 130\,000$. The spectrometer aperture is a 27 mas \times 450 mas slit in the primary mode and can be used in a long (4-arcsecond) slit mode by selecting between one and six orders using a spatial filter. For high stability and reliability, the spectrometer has a minimum number of moving parts with just two cryogenic mechanisms: the slit mechanism and the post-slit viewer in a continuous flow liquid nitrogen cryostat. Outside the cryostat, an on-board SCAO system can be used in conjunction with the telescope adaptive mirrors to correct the PSF. Otherwise, SIMPLE may be used with either the MCAO or LTAO post-focal adaptive optics modules.

The SIMPLE beam is picked off from 2500–3000 mm from the telescope focus, so SIMPLE is easily located at any of the telescope ports or behind any of the post-focal AO modules. The instrument pre-optics contains a secondary guiding system to maintain alignment between SIMPLE and the telescope axis, the field de-rotator for the long slit mode and the instrument calibration unit. The spectrometer works on the principle of a double pass from a standard reflection grating and focuses the spectrum onto a 12k \times 4k pixel focal plane array with sampling of 2–3 pixels. The total mass of the instrument is 7700 kg in a volume of 4 m \times 4 m \times 5 m. The vacuum vessel is a cylinder 1.8 m \times 2.3 m. The instrument is mounted on a mechanical rotator.

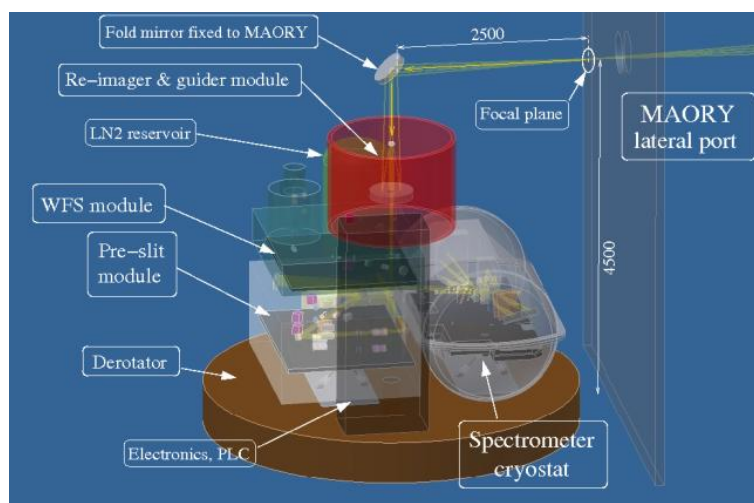

Figure 4.16. The SIMPLE layout showing the beam picked-off from the re-imaged (by the MCAO) telescope focal plane.

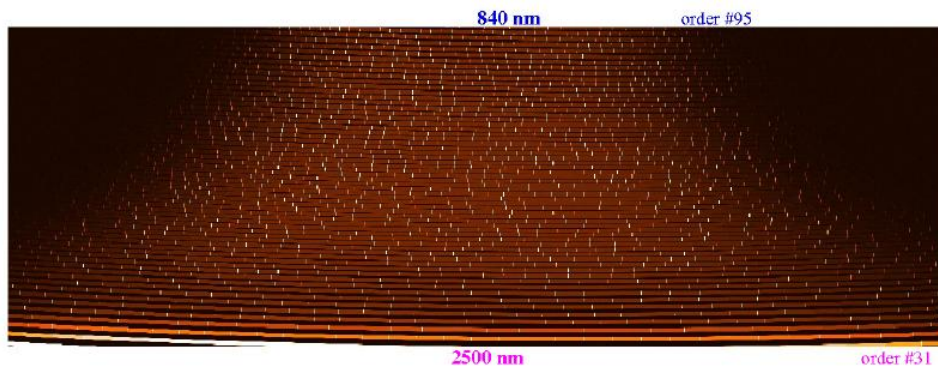

Figure 4.17. The SIMPLE echellogram on $3 \times 4k \times 4k$ arrays.

5 OPERATIONS

5.1 SCOPE

This chapter describes the operational concepts and plans with the goal of achieving the E-ELT science requirements, covering aspects related to the observatory management; science, technical, maintenance and logistic operations; off-site development and support; upgrade paths; staffing requirements; and operations budget.

The detailed operations plan will be established in the construction phase. At the moment, a realistic baseline operation scenario is defined in this document to show how the integration of the E-ELT in the joint Paranal Armazones (hereafter referred to as “the Observatory”) facility will take place, how science operations will address the requirements of the E-ELT scientific requirements, and to enable a realistic operations budget assessment already at the present stage.

The main goals of E-ELT operations will be to:

- Maximise the scientific productivity of the E-ELT, making it accessible to scientists with user-level expertise in the use of other large visible-infrared ground-based facilities.
- Ensure an optimal performance level of telescope and instrumentation by extensive use of metrology and predictive maintenance, aiming at an amount of technical downtime below the 3% level.
- Assure a safe, efficient and cost-effective operation of the facility.
- Deliver scientific data of high and consistent quality together with all ancillary data needed for their calibration up to established levels.
- Maximise the common use of resources with other ESO facilities.
- Provide opportunities for technical upgrades and development of new instruments and AO systems over the lifetime of the facility.

The operations planning maximises synergies with the joint operation of all the facilities at the Observatory, including the E-ELT, the VLT, the survey telescopes and other ESO facilities that may be based on Paranal at the time when the E-ELT enters operation. This applies to off-site facilities as well, particularly to the Garching operations segment, within which E-ELT operations will be fully integrated. In particular, the same science operations units, both in Garching and in Chile, will operate the E-ELT and the Paranal telescopes.

Most of the observing time at the E-ELT is expected to be made available to the community in the same manner as for the VLT and allocated through a peer-review process. The execution of observations will take place predominantly in service mode, in which observations fully pre-defined by the users will be executed under suitable external conditions and selected according to a number of criteria dominated by scientific priority. Visitor mode will be supported as well, and remote mode will be added later, after at least one year of regular E-ELT operations. Adequate software will be made available to users for the definition of observations and prediction of telescope and instrument performance, and data reduction pipelines will be available for at least the most frequently used modes of all instruments. All science observations, calibrations and ancillary data will be permanently stored in the ESO Science Archive to ensure their preservation and long-term access.

In accordance with the E-ELT top-level requirements, the operations plan assumes that instruments and AO post-focal units will be permanently mounted at their corresponding focal stations, allowing rapid switch-over (up to 30 minutes) between any of them.

The facility will be designed and built to be modular in character and, wherever possible, self-diagnosing: each device will have provisions for monitor points that are reported to the control computer in real time allowing the engineering, maintenance and science operations crews to detect gradual and/or sudden changes in performance so as to enable timely corrective actions. Detailed monitoring of the scientific data and associated calibrations, as well as long-term trending, will be used to assess the health of instruments and determine the need for intervention.

The technical performance of the facility will be further measured using operational cost as a metric. The operation cost of the facility will include all directly attributable costs and ESO overhead activities.

Being an ESO facility, E-ELT operations will obtain general support from ESO in host country relations and ESO representation, logistics (including shipping organisation and support including custom clearance), contracts and procurement, finance, human resources, legal advice, outreach and web presence, among others.

5.2 SCIENCE OPERATIONS GOALS, SERVICES AND PERFORMANCE MONITORING

The implementation of science operations will be geared to fulfilling the goals established by the E-ELT science policy, maximising the time available for scientific observations, and optimising the allocation of available time according to scientific merit as the predominant criterion. To this end, the Observatory will provide modalities of use of the facility adequate to the scientific goals of each project, and observations will be mostly flexibly scheduled to make the best use of available atmospheric conditions. A calibration plan will be executed by the Observatory to guarantee that scientific data can be calibrated up to a well-specified level of accuracy. The calibration plan will form the basis for assessing the system performance by continuously monitoring selected parameters. All the science data obtained and their related calibrations will be stored in the ESO Science Archive, to ensure the long-term preservation and accessibility of the data to the entire scientific community through appropriate interfaces.

ESO will provide all potential users of the E-ELT with the documentation describing the most relevant characteristics of the telescope, its AO systems and its instrumentation, as well as instrument performance simulators enabling users to assess the feasibility of their planned observations. Tools and support will be available to users for the preparation and definition of their observing programmes.

Following the execution of observations, ESO will deliver raw data to the users or, whenever all raw data would involve a prohibitive data volume, data with a minimal amount of processing, together with all calibration data required to remove the instrumental and atmospheric signature from the scientific data. Ancillary information concerning environmental conditions at the time of observations, telescope, instrument and AO performance, as well as links to support documentation relevant to the characterisation of the data, will be part of the data package. For most instrument modes it is planned to provide users with data processed by pipelines provided by the instrument builders. The pipeline modules will be provided too, so that users can adapt the data processing to specific needs of their scientific goals. Users will be encouraged to publish their science-ready, processed data through the ESO Science Archive Facility.

ESO will monitor the scientific performance of the facility and its operation in various ways. To this purpose, it will maintain statistics based on widely accepted bibliometric standards applied to the papers based on E-ELT observations and measurable for other observatories as a benchmark of the E-ELT performance. It will also pay attention to scientific results that could be obtained by exploiting characteristics unique to the E-ELT or to its operations model. The percentage of observations executed outside the specifications provided by the user in service mode, the sources of operational overheads, and the different categories of time losses will be closely monitored and periodically assessed in an attempt to gain operational efficiency. The quality control process will monitor the performance of the telescope and instruments by comparison to a nominal performance derived from instrument modelling and from actual performance measured during commissioning

5.3 OBSERVATORY MANAGEMENT OVERVIEW

Fundamentally, the E-ELT will be operated as an additional telescope within the La Silla Paranal Observatory. Assuming that the current ESO management structure is maintained in the long-term future, the E-ELT will be operated by the LPO and Data Management and Operations (DMO) Divisions within the Directorate of Operations.

E-ELT operations will be embedded within a general scheme encompassing Paranal and Armazones. This applies to on-site operations, where most tasks will be performed by single teams having responsibilities on all facilities; and also to the science operations model where the E-ELT will use the same tools as the other facilities of the Observatory. In particular, the processes and tools of programme preparation, selection, execution, and data management shall be common. This will apply both to the tasks carried out on-site (programme execution and selection, instrument performance maintenance) and off-site (user and observatory support, programme preparation, data quality assurance and processing, long-term archival).

The Observatory Organisational Chart in the E-ELT era is foreseen to mirror the current organisation of the Paranal Observatory, as given in Figure 5.1. Operations units providing off-site support and other units of the organisation with which the Observatory interfaces are also indicated in the figure.

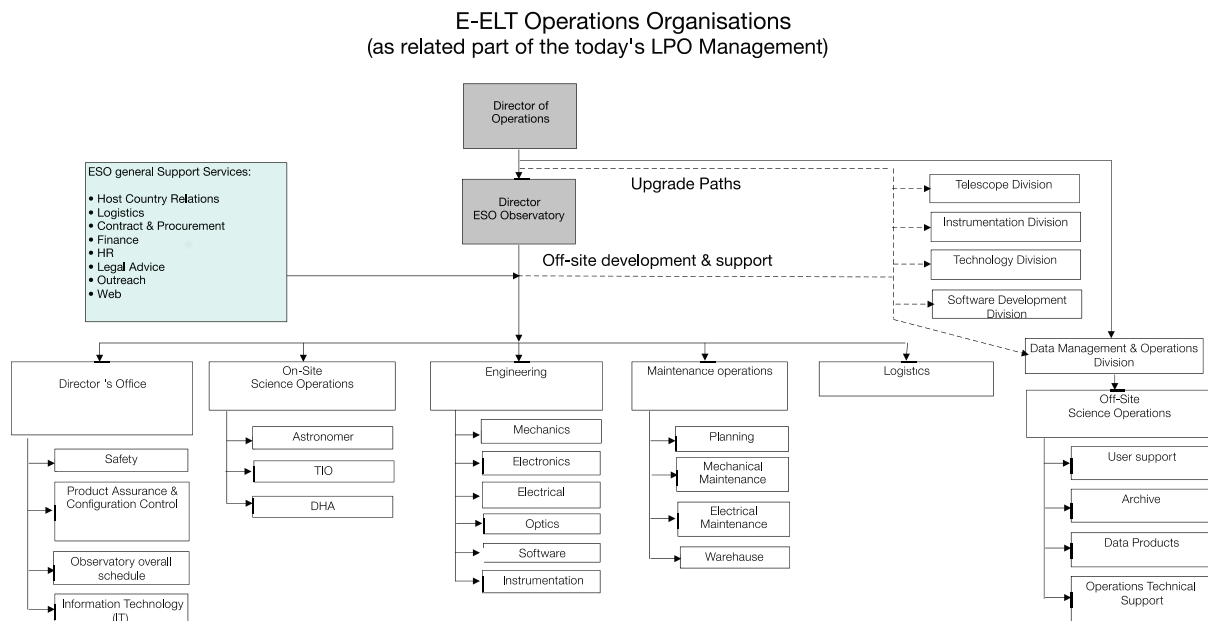

Figure 5.1. E-ELT operations organisation.

The off-site operations segment is hosted by the DMO Division, where operations are supported by the User Support, Data Products, and Operations Technical Support Departments.

General engineering support and upgrades to the E-ELT facility, its instrumentation and subsystems will be provided by the Garching-based Instruments, Technology, Telescope and Software Divisions.

Formal structures extending across all relevant operations departments will be established for each instrument at the E-ELT. Such structures, called instrument operations teams, will be analogous to those existing for the VLT.

One member of the on-site science operations staff will act as instrument scientist for each E-ELT instrument. The role of the on-site instrument scientist is to maintain expert knowledge of the instrument at the observatory, to ensure that the instrument is always in nominal operational conditions, and to coordinate the resources made available by the organisation for the maintenance and upgrade of the instrument. The instrument scientist chairs the instrument operation team and is assisted in these tasks by it.

5.3.1 SYNERGIES WITH PARANAL

The construction of the E-ELT on Cerro Armazones as part of the Paranal Observatory will provide operational and scientific synergy with the VLT and other telescope facilities on Paranal. The integration of the E-ELT into the Observatory removes the need for duplication of some support facilities on Armazones,

although those on Paranal may need upgrades to support the E-ELT. Facilities on Paranal providing E-ELT support are:

- The control room of the E-ELT, to be integrated within the Paranal control room (a reduced control room within the E-ELT dome will be in place for commissioning and day-time operations);
- The coating infrastructure (handling tools, infrastructure, etc.);
- Paranal Residencia, or extension of the dormitories;
- Workshops, integration halls, warehouses;
- Power generation system; extended Paranal facilities and underground line to Armazones;
- Recreational and sport facilities;
- Medvac facilities;
- Canteen;
- Vehicle maintenance facilities;
- IT / network support;
- Handling facilities (forklifts, mobile cranes, transportation trailers, etc.)
- Liquid nitrogen production plant;
- Garbage disposal;
- Radio communications;
- Road maintenance;
- Petrol station;
- Airstrip.

Only the personnel needed to assure the security of the site, the execution of the preventive and corrective maintenance, including recoating of the mirrors and local infrastructure maintenance, and the crew to configure the telescope and the instrument, will work on Armazones. All other staff will work at the facilities on Paranal.

It is not planned to have on-site staff (including engineers, technicians, astronomers, administration and logistics personnel) exclusively dedicated to the support of the E-ELT. The intensive use of already existing on-site staff in the support to E-ELT operations makes experienced personnel available from the beginning and ensures the synergies with the support to other Paranal facilities, reducing training needs. It also provides opportunities for existing staff to develop new skills with the addition of a cutting-edge facility.

The early success of the E-ELT critically depends on having in place a sound scheme of operations and in transferring the experience acquired with the operation of the VLT. Conversely, the efficient simultaneous operation of the VLT and the E-ELT, once the latter becomes available, will depend on the ability of ESO to maintain operations at both observatory locations aligned and so to reuse development efforts at both facilities. By default, unless highly specific to the operation of the E-ELT, each change in the science operations plan made for the E-ELT will be considered for implementation at the VLT as well. This same principle will also apply to the design and requirement of the tools to be used in engineering, maintenance or science operations, or by the users when accessing the E-ELT. Applicability to the VLT and its instruments will be a part of the requirements unless the tools under discussion are specifically related to the E-ELT or unless the maintenance of separate tools for the VLT and the E-ELT is proven to be both sustainable and more cost-effective than unification.

To avoid interference between the two sites by the use of the lasers for the laser guide stars, there will be a software tool based on the short-term schedule at each telescope on Paranal and Armazones that will prioritise laser-assisted observations and prevent disruptions and interferences among the different telescopes that, being aware of the short-term schedule of the two sites, will coordinate the operations avoiding as much as possible interruption of observations from either site.

Operations activities and facilities will be distributed to the following locations:

Paranal

- Management of the observatory;
- Science operations support;
- Control room;
- Main overhead electrical power: arrival from the grid (under evaluation also alternative options), and first distribution;
- Back-up power generation and distribution to both sites;
- Instrument maintenance;
- Workshops;
- Assembly hall;
- Storage hall;
- Residencia and canteen;
- Offices;
- Vehicle maintenance;
- Procurement support;
- IT support;
- Fire fighting (TBC depending on the final time to reach Armazones);
- First aid (TBC depending on the final time to reach Armazones);
- Management, administration, logistics;
- Library.
- Remark: During the AIV phase, initial storage and assembly of the mirror segments could partly be on Paranal.

Armazones

- Telescope;
- Coating facilities;
- Emergency dome back-up power generator;
- Control room for commissioning and maintenance;
- Local infrastructures (chillers, liquid nitrogen generator, compressed air, fire fighting);
- Small dormitory and canteen;
- Site security.

Garching

- Off-site science operations;
- Off-site maintenance and development;
- Administrative support (general ESO overhead).

Vitacura (general ESO overhead)

- Administrative support;
- Astronomer science facilities.

Armazones will be connected via a road to the B710 road close to the entrance to Cerro Paranal for transportation of staff, devices and instruments.

An optical fibre link will provide high performance network connection between Armazones and Paranal.

5.4 OPERATIONS ACTIVITIES

The work breakdown structure for operations activities is given in Figure 5.2.

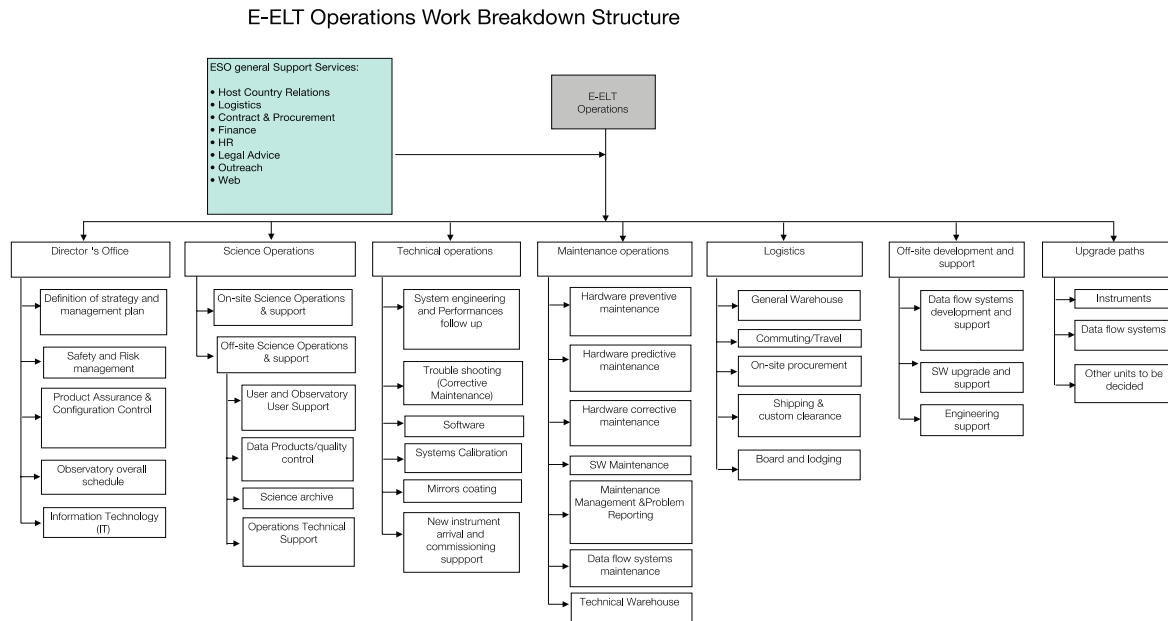

Figure 5.2. E-ELT operations work breakdown structure.

5.4.1 OBSERVATORY MANAGEMENT

The Observatory management, in addition to defining the strategy and the management plan of the observatory, includes:

Safety and risk management, including the maintenance of a risk register and the identification of mitigation strategies. The Observatory safety officer reports directly to the Observatory director.

Product assurance / configuration control. A configuration manager will monitor the overall implementation of processes and activities undertaken at the observatory as well as products delivered to and by the Observatory. Configuration control of the facility will inherit from the construction phase the as-built deliverables. The procedures already in place for approval and implementation of changes to the original configuration will be updated to cover the particularities of the E-ELT.

Definition of the Observatory schedule, which includes the overall science operations schedule, the major technical interventions (both that affect and do not affect science operations), the major recoating activities (that affect night-time observation), installation/commissioning of new instruments, etc.

General IT, including the following services:

- Accounts: User accounts on all type of platforms;
- E-mail: Access to the electronic mail system;
- FTP: Interface to transfer files using the File Transfer Protocol;
- Printers: Core printers and print services;
- Storage/disc space: Central, local, scratch disc areas;
- Media servers: Read/write from/to different type of media (DAT, CD);
- Remote access to ESO;
- Videoconference facilities;
- Safety procedures for ESO IT Users and Equipment;
- Security;
- Telephone services and hardware;
- Maintenance of the network infrastructure.

As a matter of policy, the management fosters communications between all parties involved in the operation and supply of the observatory. The management of the Observatory includes the processes assuring proper communication between the various teams, departments and crews involved in operation and servicing of the facility.

5.4.2 ON-SITE SCIENCE OPERATIONS

5.4.2.1 INSTRUMENT-RELATED ACTIVITIES

Instruments and their modes will be characterised during their commissioning. Further partial characterisations will be carried out as needed whenever elements or modes of the instrument are added, upgraded, or replaced. An important fraction of the time of on-site astronomers is expected to be devoted to the various support activities required to maintain the instruments in optimal operations conditions, well characterised and with complete and updated documentation. The Data Interface Control Board, chaired by a data interface control scientist based in Garching, will be responsible for the compliance of the data and metadata produced by the E-ELT with the established standards.

During routine night-time observations, the telescope and instruments will be operated, in collaboration with a night-time support astronomer, by specifically trained telescope and instrument operators, who will be knowledgeable about all the subsystems with which they need to interact under normal conditions. They will also be able to diagnose common problems and to implement appropriate solutions. Instrument operators will specialise in one or more instruments, and are able to operate the others during routine night-time observations. The instrument operator, in coordination with the telescope operator, will be in charge of the execution of observations under the direction of the night-time astronomer.

Quality control reports will be regularly produced off-line on a daily basis and made available to the on-site science operations astronomers. The reports will monitor instrument performance and indicate possible needs for corrective actions.

On a daily basis, the on-site science operations team will ensure that the instrument configuration matches the visitor requests and the foreseeable requirements of executable observations in the service mode queues. Changes of instrument configuration will be identified and communicated to the engineering teams for implementation.

The night-time astronomer, with the help of suitable tools, will ensure the execution of the calibration plan for each instrument used on a given night. Calibration plans are delivered for each instrument at the time of commissioning.

The execution of the daytime calibration plan will be performed according to previous night's observation and the general instrument calibration plan. Whenever possible, on-sky calibrations will be executed at twilight.

5.4.2.2 SCHEDULING AND EXECUTING OBSERVATIONS

The Armazones peak will be equipped with facilities to measure and process the atmospheric profile and transparency over the observatory and its surroundings on a near-real-time basis. Besides providing robust statistics for site characterisation during the lifetime of the observatory, atmospheric monitoring will allow the night astronomers to decide on the suitability of the prevailing conditions for the execution of observations in the observing queues. The atmosphere characterisation tools will also include forecasting services predicting the evolution of the conditions on timescales of several hours.

From Figure 5.3 it is clear that the E-ELT will be able to operate and to correct for ground layer turbulence under essentially all atmospheric conditions. Single conjugate adaptive optics observations will be feasible in the first three quartiles of the seeing distribution, while extreme adaptive optics observations will be limited to the first two quartiles.

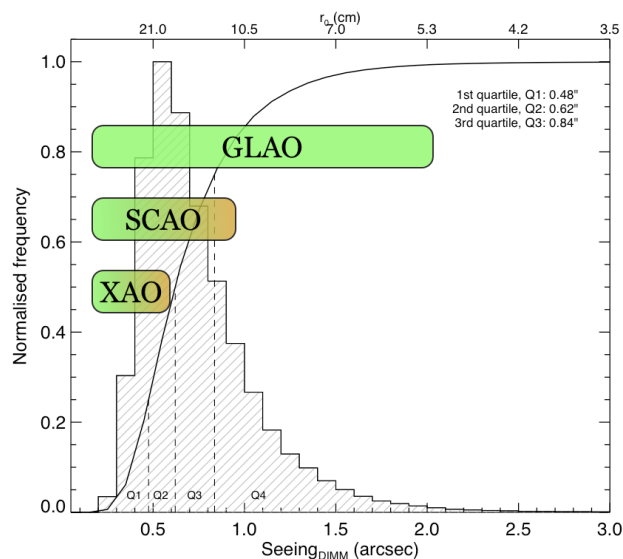

Figure 5.3. Seeing (top axis: Fried parameter) distribution for the atmosphere above Armazones (2004–2011). The 25, 50 and 75 percentiles of the distribution are indicated. The operability range for ground-layer adaptive optics, single conjugated adaptive optics and extreme adaptive optics is over-plotted.

In the baseline service observing mode, the night-time astronomer will select the observations to be executed from a general queue. The observation queue will contain observation blocks submitted in advance by the users, including sufficient information to judge their executability at a given time. The management of the observing queue is a responsibility shared between on-site operations (for decisions on the short-term scheduling of observations) and off-site operations (for the validation of observations included in the observing queue and the preparation of the observation queue itself).

In the task of selecting observations for execution, the astronomer will be assisted by tools that employ decision algorithms based on scientific priorities and elements of observing strategy defined by the users. The observation selection aids will also take into account the atmospheric conditions and their forecast. In the other modes, where real-time interaction of the user with the facility is required, the sequence of execution of the observations will be decided by the users themselves.

Upon completion, the night-time astronomer will use the user-specified constraints and the quick-look results provided by the instrument pipelines to decide whether or not the observation needs to be repeated. Final acceptance of observations as compliant with the users' requirement is granted only afterwards and once full quality control has been performed.

Night-time astronomers, with the assistance of the telescope and instrument operators, are in charge of introducing any pertinent information in the night log.

In addition to their role in the execution of the observations and the management of the service mode observing queues, on-site astronomers will be in charge of supporting remote mode users and visiting

astronomers during the execution of their observations and the preparations immediately preceding them.

The E-ELT will be able to carry out Target of Opportunity (ToO) observations. Users having approved ToO programmes will be provided with the means to notify the observatory at short notice of the need to execute them. The notifications will be immediately available to the staff in charge of planning the short-term schedule. The execution of Target of Opportunity observations will be decided upon by the night-time astronomer on the basis of the external conditions, the urgency of the observations, and the priority of other scheduled regular programmes.

Science observations obtained in any mode will be transferred to the ESO Science Archive in near-real time. An on-site data handling administrator will monitor the integrity of the science data stream. Data handling administrators will also maintain the on-site databases.

5.4.3 OFF-SITE SCIENCE OPERATIONS

5.4.3.1 LONG-TERM SCHEDULING

The telescope long-term scheduling process collects the scientific rating of proposals obtained through peer review and supports the Director General by providing schedules that take into account the technical feasibility and the expected availability of suitable conditions. The ultimate authority for the approval of programmes for execution will rest with the ESO Director General. The frequency of calls for proposals and the policies for allocation of time are defined in a science policy document.

Long-term scheduling of the E-ELT will be supported by comprehensive scheduling tools taking into account factors such as scientific priority, chosen mode of execution, statistics of conditions expected at the site, user-specified constraints, time-critical observations, or reserved time for calibrations.

5.4.3.2 OBSERVATORY AND USER SUPPORT

Off-site support to the observatory is provided mainly by the User and Observatory Support Department, which acts as the point of contact between the observatory and other operations groups or the user community. It maintains the observing queues, distributes observation preparation tools and documentation, ensures the quality of the predefined observations for execution in service or remote modes, solves execution problems, and participates in the instrument operations teams.

The data flow system allows a full definition of all observations, including those to be executed in visitor and remote mode, well in advance of their execution. This is a key element in guaranteeing the robustness of operations and maintaining the scientific efficiency of the facility, as it enables ESO to review the technical correctness of the observations and optimise programme execution strategies jointly with the users. Support needed for real-time changes of observation blocks to be executed in remote and visitor modes is provided by astronomers on-site.

Due to the high cost of E-ELT observing time, normally no attempts will be made in service mode at correcting problems with the definition of observations at the time of them being detected, unless observations happen to be time-critical. Instead, runtime execution problems will be reported to the User and Operations Support Department, which will follow up the problem and work together with the users if needed until the observation blocks are deemed to be executable.

The User and Observatory Operations Support Department uses tools to monitor the progress in the realisation of the long-term schedule and to forecast significant deviations that require preventive actions to avoid schedule clashes or undersubscriptions.

5.4.3.3 QUALITY CONTROL AND PERFORMANCE TRENDING

Most science observations and calibrations obtained at the observatory will be processed by instrument pipelines and subjected to quality control. Performance monitoring will take place continuously and

automatically according to quality control procedures specific to each instrument and established by the instrument scientist in collaboration with the instrument operations team. Quality control reports will be made available as soon as they are produced.

Long-term monitoring of the performance of the instruments will be the task of the Data Processing and Quality Control group. The quality control parameters extracted by the data processing pipelines will be used to monitor the performance and diagnose any deterioration that may require preventive maintenance before the performance goes outside its nominal limits. They will be also used to immediately quantify the effects of instrument interventions.

5.4.3.4 OPERATION-CRITICAL IT SUPPORT

Most mission-critical operations services will reside in hardware located in Garching in a dedicated environment, ensuring high availability and fast corrective action when needed as well as physical proximity to software developers. The management of the hardware, and the installation and monitoring of the software installed on it, will be under the responsibility of the Operations Technical Support department.

This department will work in close collaboration with the ESO general IT services in Garching to ensure the required level of availability of the communications infrastructure with Chile, with the appropriate units of the Science Operations Department at the observatory, and with the Data Flow Infrastructure and Software Engineering Departments in Garching to ensure the proper installation and performance of the operations-critical software. Operations-critical information will be collected in databases and immediately replicated to the Observatory. On-site observatory operations are designed so as to allow fully autonomous operations for an extended period (up to about one week) with minimal decrease of efficiency in the event of a prolonged communications disruption between Chile and Europe.

The maintenance of operational databases is managed in an ESO-wide manner. Real-time database access in Garching and Paranal will be critical for the operation of the VLT and E-ELT, and active monitoring of the synchronisation between the operational databases in Garching and the mountain will take place from both sides.

5.4.3.5 DATA HOLDINGS AND ACCESS

ESO is committed to the long-term preservation and accessibility of all the scientific data obtained with the E-ELT, their associated calibrations and ancillary information, as well as processed data products described below. Data obtained with the E-ELT will be stored in the ESO Science Archive Facility and will be made available to the worldwide community at the end of a proprietary period to be defined by the science policy document.

The Science Archive Facility will also store pipeline-processed data products and higher level, science-ready data products. These include calibrated images, spectra, and catalogues. Science-ready data products will contain metadata compliant with Virtual Observatory standards and are made available to Virtual Observatory tools through publication in the appropriate registries.

5.4.3.6 DATA FLOW SYSTEM MAINTENANCE

The data flow system and its associated tools will be developed and maintained at the ESO Headquarters, with requirements provided by the Directorate of Operations. On-site software maintenance staff will be provided with training or instructions for installation of components and minor troubleshooting.

5.4.4 TECHNICAL OPERATIONS

Technical operations at the site are envisaged to take place in a context similar to that employed at the VLT today. The following activities are considered with the scope of technical operations at the site.

5.4.4.1 SYSTEMS ENGINEERING AND PERFORMANCE ANALYSIS

Each subsystem of the E-ELT provides real-time metrology that monitors performance and status during operations. The subsystem monitoring forms an integral part of operations. Every observation is also an engineering test of the system.

Apart from the subsystem-level monitoring (as requested at) and like at the VLT, the nightly logging activities generate useful diagnostics for the performance of the global system.

The monitoring of the overall metrics from the telescope forms a key task of the operations team.

5.4.4.2 TROUBLESHOOTING (CORRECTIVE MAINTENANCE)

In spite of the efforts to provide a fully functioning and reliable machine, we expect the continuous need for intervention, in particular during the first years of operation. Trained and experienced engineers will keep the dome, telescope and its instruments functional. We also consider it necessary that an understanding of the root causes of failures is established. This will require the presence of highly skilled mechanical, electronic and optical engineers with a deep knowhow and understanding of the systems.

5.4.4.3 COATINGS

To keep the telescope at its requested performance, the Observatory will provide a maintenance plan for the optics. The reflective and micro-roughness properties of the mirrors as required to satisfy the top-level requirements are monitored and the short-term re-coating plan is established accordingly.

It is estimated that, to keep the primary mirror at the required performance, at least two M1 segments will be recoated per day.

The mirror coating maintenance plan (washing and coating) shall require less than ten nights per year:

- M1 shall use on average one night per year for operations arising from the maintenance of the segments; this is considered to be mostly phasing operations that may not be executed in twilight;
- M2 shall be recoated once every three years and the operation shall be completed in less than five days;
- M3 shall be washed or coated every two years with the maintenance requiring less than two days;
- M4 shall need less than two nights every year (or six nights/3 years);
- M5 shall need less than three nights every year — this procedure will be coordinated with M3 operations as the latter needs to be removed from the telescope prior to an operation on M5;
- M6 coatings will place restrictions on the foci used but will not require scheduled technical time.

5.4.4.4 INSTRUMENT HANDLING AND TECHNICAL SUPPORT

The E-ELT instruments will be assembled, integrated and verified before shipment to the site. The process of preparation of an instrument for E-ELT on site will be composed of re-integration; (re-)testing at the observatory facilities; integration on the telescope foci; on-site commissioning; and acceptance.

The handling and transportation of an instrument from the integration hall to its foci shall occur with the minimum number of lifting (uploading/downloading) processes to minimise risks.

With the exception of those to be placed at the coudé focus, instruments will be assembled in the integration laboratories, reducing the time necessary at the focal stations thus limiting the interference with other telescope activities.

Once an instrument has been accepted by the Observatory it shall be under strict configuration control (hardware, software and documentation, manuals, drawings, etc.). The instrument scientist will be responsible for its performance, maintenance and configuration control.

A specialised crew of engineers will maintain the instruments (preventive and predictive maintenance, pumping cryostats, etc.) and will support the installation of new instruments. These engineers will be part of the La Silla Paranal instrumentation support group.

5.4.4.5 TELESCOPE AND DOME SUBSYSTEMS PREVENTIVE MAINTENANCE

Excluding the telescope and dome as systems on their own, the subsystem maintenance tasks include:

- Pre-focal station mechanisms and optics;
- Lasers, remote check of status, shutter and other electro-mechanical functions, servo loops, diode currents, cooling baseplate temperatures, crystal temperature, optical powers, etc.;
- Calibration of relative power meter, wavemeter, service tools, etc.;
- Laser launch telescopes through *in situ* inspection, fine-tuning of servo loops, exit optics cleaning (if not sealed), preventive replacement of parts (diodes, etc.) based on logged performance, data replacement, safety system check;
- Quaternary and M5 calibrations and maintenance;
- Secondary and tertiary mirror actuator inspection and regulation;
- Site monitoring facilities;
- General control system.

The activities include servicing and recalibrating the servo loops and interaction matrices for the deformable mirror and tip-tilt system, updating the look-up tables for the primary mirror, improving (updating) the pointing model based on observational data and general optomechanical support of the subsystems.

5.4.4.6 COMMISSIONING AND DELIVERY OF NEW SYSTEMS

The La Silla Paranal Observatory procedure that identifies the steps for the handover of systems will be augmented, if necessary, to cover special needs for the E-ELT. This includes a procedure of how commissioning teams hand over systems and how the Observatory accepts the system.

Any new system that is delivered to the Observatory will include:

- Operation and maintenance manuals;
- System transfer document (including the commissioning report that will remain the reference document for the system performance maintenance of the Observatory);
- The full as-built documentation, including optical, mechanical and electrical drawings;
- A procedure to verify the operational system performance on site;
- A procedure to verify the operational system configuration.

5.4.4.7 POST-EARTHQUAKE INSPECTIONS

The Observatory maintains a seismometric station to register and classify the strength of earthquakes. Depending on the measured strength (i.e., peak ground accelerations) post-earthquake inspections of the installations and the systems are carried out to identify possible degradations or damage and to initiate corrective measures.

5.4.5 MAINTENANCE OPERATIONS

5.4.5.1 PRIMARY MIRROR SEGMENT EXCHANGE

This operation is carried out by a dedicated crew twice during the day. The crew follows the segments back to the storage facility in the dome and is responsible for their storage and refurbishment (coating, calibration etc. of the segment).

5.4.5.2 TELESCOPE MOUNT INSPECTION, MAINTENANCE AND REGULATION

The following operations will occur according to a condition-based maintenance schedule:

- Encoder cleaning and calibration;
- Hydrostatic pad inspection and regulation;
- Recirculation pumps and cooling circuit inspection;
- M1 subassembly, edge sensors, actuators;
- M1 segment cranes;
- Other mirror position actuation systems;
- Electrical and compressed air system maintenance.

5.4.5.3 DOME INSPECTION, MAINTENANCE AND REGULATION

The mechanisms of the dome shall be inspected and regulated regularly. The following activities are foreseen:

- Observing-door inspections and adjustments;
- Ventilation system (louvers etc.) inspection and adjustment;
- Air-conditioning plant regulation and inspection;
- Dome rotation system maintenance;
- Dome crane and lifting platform maintenance;
- Other elevator and crane maintenance;
- Machines and equipment;
- Lubricant and wear particle analysis;
- Vibration monitoring;
- Infrared thermography.

5.4.5.4 INFRASTRUCTURE SUPPORT

The observatory infrastructure maintenance (chillers, power generation and distribution, etc.) will be contracted out. The skill sets required are not observatory-specific and therefore are cheaper and more effectively procured on the open market.

5.4.5.5 GENERAL MAINTENANCE

General maintenance will include refilling of cryostats, checking vacuum systems and replacing line replaceable units. The use of LRUs reduces *in situ* repair and allows for a clear stock of parts with defined and testable interfaces.

Experience at Paranal has shown that if the device is custom-built, the expertise in maintaining and calibrating is quickly lost at the supplier. We therefore also foresee the need to repair on site some of the LRUs.

5.4.5.6 HARDWARE CORRECTIVE MAINTENANCE

The RCM (Reliability Centred Maintenance) discipline will be implemented to establish the minimum corrective effort required to increase in cost-effectiveness, telescope uptime, and a better understanding of the level of risk. The result is a maintenance programme that focuses resources on those items that cause the most disruption when they fail.

RCM emphasises the use of *predictive maintenance* techniques in addition to traditional preventive measures. This approach, already the baseline of operations at Paranal, leads to the minimum reactive maintenance needs.

5.4.5.7 THE PROBLEM REPORTING SYSTEM AND COMPUTERISED MAINTENANCE MANAGEMENT SYSTEM

The operations-wide Problem Reporting System (PRS) currently in use at Paranal allows the exchange of information among all operations groups, regardless of their location. It is likely that this tool will be obsolete by the time E-ELT comes on-line. Irrespective of implementation, the PRS allows problems to

be communicated and documents any matters requiring corrective action, in which a generator and an addressee can be identified (being either a group or an individual) and where a resolution is needed.

The PRS generates tickets, assigns them to one or more group heads, identifying the area of operations to which the item belongs, and keeps tracking of actions until the item is resolved. Each ticket is logged in a searchable database.

This tool could possibly be integrated into the Computerised Maintenance Management System (CMMS) so that the PRS and the CMMS communicate with each other, thereby providing a single entry into the system whereby the creation of a problem will also generate the work order, with the inventory control, property control and tracking of all E-ELT equipment. The creation of a problem report by any of the operation groups shall finally include everything linked to it, including the documents, the procedures, the order of the spare parts needed to fix it, and the time required to solve the problem.

E-mail and PRS/CMMS-based procedures shall ensure that all matters concerning on-site operations are seamlessly transmitted amongst shifts on the mountain and remain available for future reference. The CMMS toolkit currently used by Paranal will also be used for inventory control, property control, corrective, predictive and preventive maintenance control and tracking of all E-ELT equipment.

This tool will not manage documentation, but will be connected and linked to the document management database. Documentation and product data will be managed by a PDM (Product Data Management) system, made available by ESO Headquarters.

Inventory control of a system is the supervision of the supply, storage and accessibility of the system items in order to ensure an adequate supply without excessive oversupply.

For the E-ELT, the inventory control is required such that at any time the status, configuration and location of equipment down to the LRU level is known. The property control is the identification of the ownership (Consortium, Contractor or ESO) of an item.

The maintenance management system is based on the elaboration of job plans for all maintenance tasks and on the generation of work orders:

- Automatic work orders for planned proactive maintenance activities such as regular inspections, preventive and predictive maintenance activities;
- Manual work order generation for corrective activities according to the results obtained from the proactive planned activities and evident presence of failures;
- A common maintenance management system will be used to track the maintenance of all inventoried items.

As a goal for ESO overall, but not necessarily a deliverable of the E-ELT project, will be to have one single software tool capable of performing the PRS and CMMS requirements together, linked to the documents and drawings PDM (Technical Archive) in Garching that will contain all the documents, procedures and drawings of the installed devices.

5.4.5.8 TECHNICAL WAREHOUSE

The handling of goods inside enclosed spaces is performed by electrical forklifts. The handling of goods in the outdoor area is performed by forklifts. The Observatory has dedicated areas to store chemicals, flammable materials, etc. The warehouse inventory and proper control of items (their stock, location, etc.) via a CMMS, already in place at Paranal, will be employed for the E-ELT. This allows the maintenance crew to follow the turnover of spare parts, establish the need for re-stocking and ensure that the requested spares are always in stock as well as controlling the spare parts delivery.

5.4.5.9 SCHEDULING OF TECHNICAL TASKS

Technical and maintenance tasks are identified as inside and outside the dome activities and are scheduled accordingly. In Figure 5.4 and Figure 5.5 the sequences of tasks outside and inside the dome

distributed over a working day are shown. From these charts the tight presence schedule of the technical operations staff is derived.

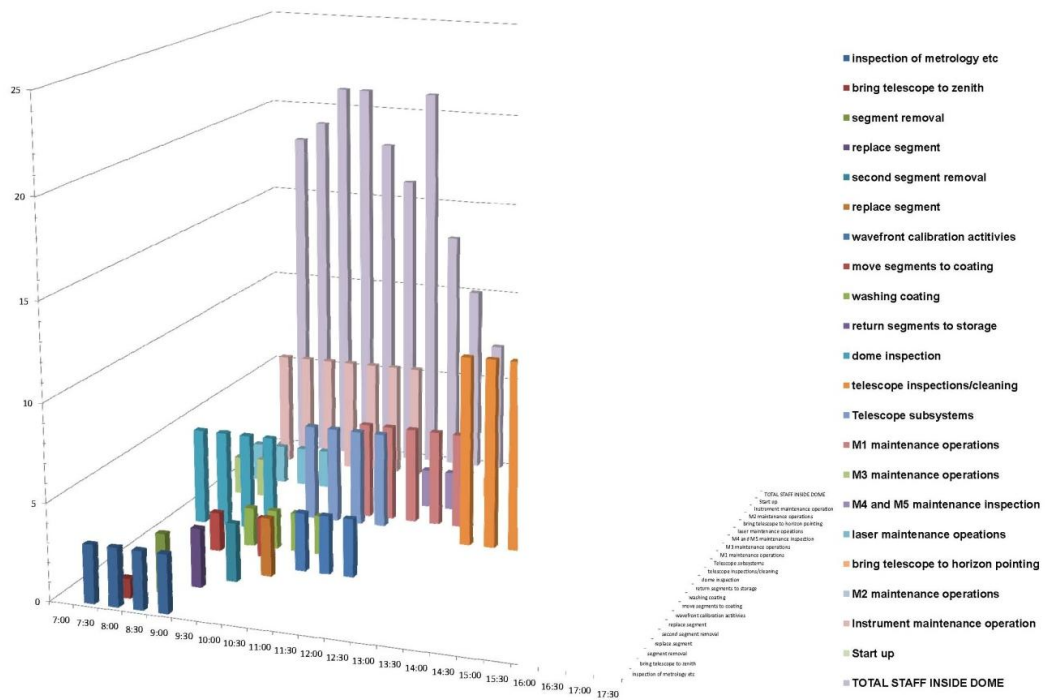

Figure 5.4. Plan for the execution of the preventive maintenance tasks inside the E-ELT dome.

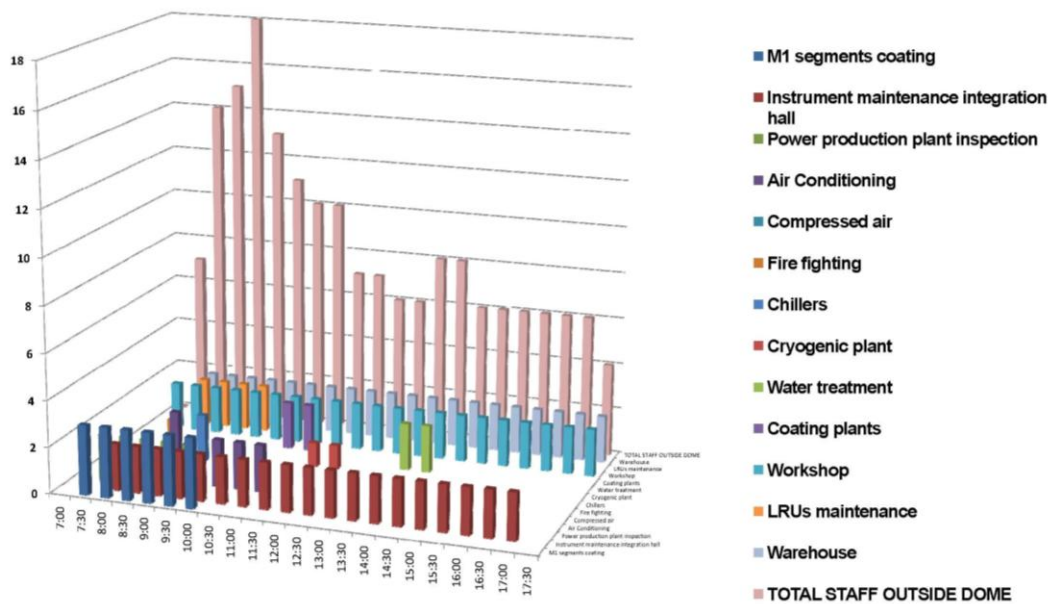

Figure 5.5. Plan for the execution of the preventive maintenance tasks outside the E-ELT dome.

5.4.6 LOGISTIC OPERATIONS

Logistical and administrative support on site will include:

- General warehousing for office supplies, vehicle maintenance and general non-telescope specific needs that the observatory has;
- Staff commuting (organisation and support);
- Reception;
- On-site procurement;
- Board and lodging;
- Site, road and building maintenance;
- Security;
- First aid.

5.5 E-ELT OPERATIONS STAFFING

This section aims at providing an accurate estimate of the total number of staff that will be required for the operation of the E-ELT as part of the Observatory. These numbers define the required share of the staff for E-ELT operations and therefore are not a pure addition to the currently existing Paranal Observatory staff since, due to the synergy and optimisation, some saving on the total staff for the future observatory can be achieved.

E-ELT operations will start formally after the commissioning of the telescope. Up to this time, site operations and AIV activities will be part of construction. The AIV team will have to be recruited and trained in line with the AIV planning. Some of AIV team members with fitting qualifications will be taken over to the operations or will be replaced by operations staff.

Operations are assumed to start in mid-2022. It is planned to have all the operations staff available beginning of 2020 so that they can familiarise themselves with operations on the VLT as well as during commissioning of the E-ELT.

The training plan will follow the VLT experience, with an AIV crew that familiarises itself with the hardware as it appears in the integration phase at the manufacturers. Then, the staff taken over from the AIV will already be trained. A few other key operations staff will be trained at the contractor's premises during the completion of the manufacturing phase, allowing them to become familiar with the systems and subsystems and their detailed characteristics and behaviour. This will be easier when the systems are still in the hands of the manufacturer. This will form a small crew of international senior engineers who will then train and transfer their acquired knowhow to younger, local engineers.

As a policy, an operations team will always be trained on any new units or upgrades either at the contractor's premises or during their installation on the site.

In each of the following sections, two tables are presented that show the planned staff needed to operate the E-ELT. The first table shows the daily staff effectively on site, working for E-ELT, and their regular working location. The second table, based on the shift/turno factor, shows the total number of staff needed to ensure a continuous presence on site.

5.5.1 SHIFT/TURNO SYSTEM

Instead of the daily commuting option, the operation of the E-ELT will adopt the shift/turno system in place at the current La Silla Paranal Observatory for the following reasons:

- Most cost-effective operation of the facility resulting in a minimum down-time;
- Quick intervention at night, if needed;
- Allows a close interaction among operations units (e.g., engineering and science operations);
- Being on site for seven days allows flexible working time;
- Long distance from place of residence (in particular from Santiago);
- Travelling cost and risk.

For the staff working on an 8 × 6 shift system, a shift/turno factor of 2.5 is applied to fully cover the daily staff on work planned. This covers also leave and sick leave. Twenty-six shifts/turnos per year minus four

shift/turnos vacation minus one shift/turno sick leave = 21 shifts/turnos per year. Therefore, to cover 52 weeks per year, 2.5 people are needed.

The FTEs of scientific personnel, who have a fraction of their time (between 20% and 50%) reserved for scientific research, already include the scientific research time. Therefore, no correction factor analogous to the turno factor needs to be applied in this case.

5.5.2 DIRECTOR'S OFFICE

	Daily staff on work						Staff ramping-up					
	PAR	ARM	GAR	Total	turno factor	Total FTE	2019	2020	2021	2022	2023	
Director's Office												
Director	0.50	0.00	0.00	0.50	1.0	0.50	0.00	0.00	0.00	0.25	0.50	
Safety Manager	0.50	0.50	0.00	1.00	2.5	2.50	0.00	0.00	0.00	0.50	1.00	
PA/Configuration manager	0.50	0.00	0.00	0.50	2.5	1.25	0.00	0.00	0.00	0.25	0.50	
IT specialist	1.00			1.00	1.0	1.00	0.00	0.00	0.00	0.50	1.00	
Administrative assistant	0.50	0.00	0.00	0.50	1.0	0.50	0.00	0.00	0.00	0.25	0.50	
Director's Office Total	3.00	0.50	0.00	3.50	-	5.75	0.00	0.00	0.00	1.75	3.50	

Table 5.1. Planning of staff on daily work.

	Daily staff on work						Staff ramping-up (turno applied)				
	PAR	ARM	GAR	Total	turno factor	Total FTE	2019	2020	2021	2022	2023
Director's Office											
Director	0.50			0.50	1.0	0.50	0.00	0.00	0.00	0.250	0.50
Safety Manager	0.50	0.50		1.00	2.5	2.50	0.00	0.00	0.00	1.25	2.50
PA/Configuration manager	0.50			0.50	2.5	1.25	0.00	0.00	0.00	0.625	1.25
IT specialist	1.00			1.00	1.0	1.00	0.00	0.00	0.00	0.50	1.00
Administrative assistant	0.50			0.50	1.0	0.50	0.00	0.00	0.00	0.25	0.50
Director's Office Total	3.00	0.50	0.00	3.50	-	5.75	0.00	0.00	0.00	2.88	5.75

Table 5.2. Planning of positions after application of shift/turno factor (FTEs).

Safety manager: This person is responsible for the oversight of the activities related to medical, emergency, fire, accident and general loss prevention and for this reason will be an ESO Staff position.

Configuration manager: The role is to perform configuration management activities, defining and implementing configuration management tools and maintaining configuration management processes and policies. The configuration manager will participate in liaison with all the concerned teams in the installation and troubleshooting of newly developed systems before handover to the Observatory. He/she will act as a point of contact between ESO Garching and the Observatory to coordinate all the necessary activities to process, analyse and complete changes and upgrades to the Observatory.

IT (Communication and network) specialists: They are responsible for maintaining the communication links between the Observatory and the external world and for network security. These positions are required also to ensure communication to the site in the event of primary system outage. Minimum qualifications for these posts should be an engineering degree in information and communications technology.

The Administrative Assistant will primarily provide secretarial and administrative support to the Director but will also undertake other secretarial duties and coordination activities assisting scientific, engineering, and visiting staff. Functions will include coordination and liaison with logistic and other units of the Observatory as well as other ESO's components and external counterparts.

5.5.3 SCIENCE OPERATIONS

	Daily staff on work						Staff ramping-up					
	PAR	ARM	GAR	Total	turno factor	Total FTE	2019	2020	2021	2022	2023	
Science operations												
Day astronomers	1.00	0.00	0.00	1.00	3.5	3.50	0.00	0.00	0.00	1.00	1.00	
Night astronomers	1.00	0.00	0.00	1.00	3.5	3.50	0.00	0.00	0.00	1.00	1.00	
Telescope operators	1.00	0.00	0.00	1.00	2.5	2.50	0.00	0.00	0.00	1.00	1.00	
Instrument operators	1.00	0.00	0.00	1.00	2.5	2.50	0.00	0.00	0.00	1.00	1.00	
Data handling administrator	0.50	0.00	0.00	0.50	2.5	1.25	0.00	0.00	0.00	0.50	0.50	
On-site Total	4.50	0.00	0.00	4.50	-	13.25	0.00	0.00	0.00	4.50	4.50	
Off-site												
User support astronomer	0.00	0.00	3.00	3.00	1.0	3.00	0.00	0.00	0.00	2.00	3.00	
Quality control	0.00	0.00	2.00	2.00	1.0	2.00	0.00	0.00	0.00	2.00	2.00	
Archive operators	0.00	0.00	0.50	0.50	1.0	0.50	0.00	0.00	0.00	0.50	0.50	
Archive management	0.00	0.00	1.00	1.00	1.0	1.00	0.00	0.00	0.00	1.00	1.00	
Operations technical support	0.00	0.00	1.00	1.00	1.0	1.00	0.00	0.00	0.00	1.00	1.00	
Off-site Total	0.00	0.00	7.50	7.50	-	7.50	0.00	0.00	0.00	6.50	7.50	
Science operations Total	4.50	0.00	7.50	12.00	-	20.75	0.00	0.00	0.00	11.00	12.00	

Table 5.3. Planning of staff on daily work.

	Daily staff on work						Staff ramping-up (turno applied)					
	PAR	ARM	GAR	Total	turno factor	Total FTE	2019	2020	2021	2022	2023	
Science operations												
On-site												
Day astronomers	1.00			1.00	3.5	3.50	0.00	0.00	0.00	3.50	3.50	
Night astronomers	1.00			1.00	3.5	3.50	0.00	0.00	0.00	3.50	3.50	
Telescope operators	1.00			1.00	2.5	2.50	0.00	0.00	0.00	2.50	2.50	
Instrument operators	1.00			1.00	2.5	2.50	0.00	0.00	0.00	2.50	2.50	
Data handling administrator	0.50			0.50	2.5	1.25	0.00	0.00	0.00	1.25	1.25	
On-site Total	4.50	0.00	0.00	4.50	-	13.25	0.00	0.00	0.00	13.25	13.25	
Off-site												
User support astronomer			3.00	3.00	1.0	3.00	0.00	0.00	0.00	2.00	3.00	
Quality control			2.00	2.00	1.0	2.00	0.00	0.00	0.00	2.00	2.00	
Archive operators			0.50	0.50	1.0	0.50	0.00	0.00	0.00	0.50	0.50	
Archive management			1.00	1.00	1.0	1.00	0.00	0.00	0.00	1.00	1.00	
Operations technical support			1.00	1.00	1.0	1.00	0.00	0.00	0.00	1.00	1.00	
Off-site Total	0.00	0.00	7.50	7.50	-	7.50	0.00	0.00	0.00	6.50	7.50	
Science operations Total	4.50	0.00	7.50	12.00	-	20.75	0.00	0.00	0.00	19.75	20.75	

Table 5.4. Planning of positions after application of turno factor (FTEs).

The science operations staff consists of technical and scientific personnel with expertise in a variety of areas. The following functions are identified:

On-site staff:

- *Day and night astronomers:* Minimum qualifications for these posts are a PhD in astronomy or astrophysics, and some experience with observational astronomy. It is assumed that the astronomers, as in today's configuration on Paranal, will have 105 nights allocated for site operation due to the constraints set by the time devoted to scientific research. This implies a shift/turno factor of 3.5 instead of 2.5.
- *Telescope operators:* Experts in using the main telescope subsystems, understanding their functions, and able to diagnose and troubleshoot the most commonly encountered problem situations with the telescope. Qualifications for these posts should be a master's degree in physics, astronomy or related science, or an engineering degree.
- *Instrument operators:* Experts in the use of one or more instruments and their subsystems, understanding their functions, and able to diagnose and troubleshoot the most commonly encountered problem situations with the instrument. Qualifications for these posts should be a master's degree in physics, astronomy or related science, or an engineering degree.
- *Database handling specialists:* In charge of local databases needed for operations, supervision of data transfer to the archive and of the replication of database contents between Headquarters and the mountain, ensuring availability of on-site data storage needs. Qualification for these posts is a degree in software engineering, with extensive background on database technologies.

Off-site staff:

- *User support astronomers:* In charge of supporting the user community in preparing their observing proposals, validating observations to be executed, and post-observation support. Also the interface between the user community and the observatory. Qualifications for these posts should be a PhD in physics, astronomy or equivalent, and experience of observational astronomy.
- *Data processing and quality control specialists:* In charge of carrying out detailed quality control of data, instrument health checks and trending, ensuring the calibration needs of each science observation are met, setting specifications for the quality control and health check parameters delivered by pipelines and providing input for their further development in close collaboration with pipeline developers. Qualification for these posts should be a master's degree in physics, astronomy or equivalent, and experience of observational astronomy.
- *Archive operators:* Responsible for maintaining the data archive and to ensure their integrity. Qualifications for these posts should be an advanced technological degree with some experience in software, archiving and database technologies.

5.5.3.1 FELLOWSHIP AND STUDENTSHIP PROGRAMME

The scientific fellowship and studentship programme will provide the opportunity for fellows and students to carry out functional work in support of the Observatory operations. It will provide substantial training opportunities to young astronomers interested in front-line observational astrophysics and enhance the connection between the Observatory and the community.

Similarly, in the engineering disciplines, student programmes will be used to give opportunities to young engineers interested in state-of-the-art technology. This will also give ESO the opportunity to identify candidates with the potential for growth within the Observatory.

5.5.4 TECHNICAL OPERATIONS

	Daily staff on work					turno factor	Total FTE	Staff ramping-up				
	PAR	ARM	GAR	Total	2019			2020	2021	2022	2023	
Technical operations												
Mechanical engineers	0.00	4.00	0.00	4.00	2.5	10.00	0.20	0.20	1.00	4.00	4.00	
Mechanical technicians	0.00	4.00	0.00	4.00	2.5	10.00	0.00	0.00	0.00	4.00	4.00	
Electrical engineers	0.00	1.00	0.00	1.00	2.5	2.50	0.00	0.00	0.00	1.00	1.00	
Electrical technicians	0.00	1.00	0.00	1.00	2.5	2.50	0.00	0.00	0.00	1.00	1.00	
Electronic engineers	0.00	2.00	0.00	2.00	2.5	5.00	0.20	0.20	1.00	2.00	2.00	
Electronic technicians	0.00	1.00	0.00	1.00	2.5	2.50	0.00	0.00	0.00	1.00	1.00	
Software engineers	2.00	1.00	0.00	3.00	2.5	7.50	0.00	0.20	0.20	3.00	3.00	
Optical engineers	0.00	2.00	0.00	2.00	2.5	5.00	0.00	0.00	1.00	2.00	2.00	
Optical technicians	0.00	2.00	0.00	2.00	2.5	5.00	0.00	0.00	0.00	2.00	2.00	
Administrative assistant	1.00	0.00	0.00	1.00	1.0	1.00	0.00	0.00	0.00	0.50	1.00	
Technical operations Total	3.00	18.00	0.00	21.00	-	51.00	0.40	0.60	3.20	20.50	21.00	

Table 5.5. Planning of staff on daily work.

	Daily staff on work					turno factor	Total FTE	Staff ramping-up (turno applied)				
	PAR	ARM	GAR	Total	2019			2020	2021	2022	2023	
Technical operations												
Mechanical engineers		4.00		4.00	2.5	10.00	0.50	0.50	2.50	10.00	10.00	
Mechanical technicians		4.00		4.00	2.5	10.00	0.00	0.00	0.00	10.00	10.00	
Electrical engineers		1.00		1.00	2.5	2.50	0.00	0.00	0.00	2.50	2.50	
Electrical technicians		1.00		1.00	2.5	2.50	0.00	0.00	0.00	2.50	2.50	
Electronic engineers		2.00		2.00	2.5	5.00	0.50	0.50	2.50	5.00	5.00	
Electronic technicians		1.00		1.00	2.5	2.50	0.00	0.00	0.00	2.50	2.50	
Software engineers	2.00	1.00		3.00	2.5	7.50	0.00	0.50	0.50	7.50	7.50	
Optical engineers	0.00	2.00		2.00	2.5	5.00	0.00	0.00	2.50	5.00	5.00	
Optical technicians		2.00		2.00	2.5	5.00	0.00	0.00	0.00	5.00	5.00	
Administrative assistant	1.00			1.00	1.0	1.00	0.00	0.00	0.00	0.50	1.00	
Technical operations Total	3.00	18.00	0.00	21.00	-	51.00	1.00	1.50	8.00	50.50	51.00	

Table 5.6. Planning of positions after application of turno factor (FTEs).

- *Mechanical engineers* will carry out on-field integration of the mechanical and optomechanical systems, maintaining, fine-tuning and improving the mechanical systems of the telescope, instruments and facilities (air compressors, chillers, etc.), which include hydraulic and pneumatic systems, electromechanical mechanisms and drives. Mechanical engineers are also required to maintain the co-generation facilities for heating and hot water as well as to call in off-site support contractors when required. The Head of Engineering will most likely be a mechanical engineer since mechanical operations are the most risky ones.
- *Mechanical technicians* will provide technical support for the operation of the telescope, keeping the performance and availability of the telescope systems on the highest level, as well as supporting the assembly, integration and verification of new telescopes and systems. They will have experience in advanced mechanical and hydraulic systems with either a university or a technical institute degree, and experience in production plants or technical service companies. Capabilities required in advanced hydraulic and pneumatic, precision mechanics, tribology and lubrication, welding, tool machining, metrology, failure analysis and basic knowledge of electricity and control, as well as basic PC computer literacy in word processing and spreadsheets.
- *Electrical engineers* will be in charge of the supervision of the contracts for the power station systems and energy distribution: High, medium and low voltages, uninterruptible power supply, carrying out the necessary maintenance, troubleshooting and improvement activities in order to supply the Observatory with the needed electrical energy. These engineers will also be involved mainly in the service troubleshooting and maintenance of the power station, its control system based on PLCs, its installations and the necessary interventions on power distribution. Minimum qualifications for these posts should be a university degree in electrical engineering.
- *An electrician* must be present on site at all times to ensure the operation of the power distribution. This critical operation is also a safety issue and this will be a staff position. Minimum qualifications for these posts should be either a technical university or a superior technical degree or alternatively at least eight years of relevant experience in working with advanced electrical equipment.
- *Electronic engineers*: There will be at least two disciplines that will require this expertise, one fully electronic and another closer to the scientific instruments. The former position will involve troubleshooting, improvements and corrective maintenance activities for digital and analogue electronic equipment used to control the telescopes and their enclosures. The control systems are based on VME (Virtual Machine Environment) computers and PLCs and involving high-precision motion control loops as well as industrial control systems. For the latter one, these persons will be responsible for the maintenance, calibration, adjustment, troubleshooting and improvement of several instruments in collaboration with other team members. Minimum qualifications for these posts should be a degree in electronic engineering.
- *Electronic technicians* will be required to service and troubleshoot digital and analogue electronics equipment, be responsible for the adjusting, troubleshooting and monitoring of scientific/astronomical equipment, perform general electronics work associated with cabling and connection, procure electronics equipment and components and maintain the electronics laboratory work areas. These persons will have either a technical university or a superior technical degree or alternatively at least eight years of relevant experience in working with advanced electronics equipment.
- *Software specialists* are responsible for software troubleshooting, development and maintenance of locally used tools, and system administration of computers running telescope and instrument subsystems. Minimum qualification for these posts should be a degree in software engineering.
- *Optical engineers* will take care of the maintenance and alignment of the several optical components of the telescopes and instruments including their optical quality control by using interferometer or wavefront-sensing equipment. This maintenance task includes CO₂-cleaning, washing and coating techniques. Minimum qualifications for these posts should be a degree in optical engineering with few years of “on field” practice experience.
- *Optical technicians* will be involved in the maintenance and alignment of the optical components of the telescope and instruments. This maintenance task includes CO₂-cleaning, washing and coating techniques. As part of the regular tasks there will be a monthly monitoring of the reflectivity of the M1 mirror as well as site dust monitoring and its maintenance. Minimum qualifications for these posts should be either a technical university or a superior technical degree or alternatively at least five years of relevant experience in working with optical equipment.

- *The Administrative Assistant* will have technical administrative studies or equivalent university education. Computer literacy in minimum PC word-processing and spreadsheets will be necessary. This person will support the Engineering Department and visiting engineering/technical staff, and will liaise with the Administration Group of the observatory for various department activities (travel arrangements, shipping/receiving). The Administrative Assistant will also be responsible for preparing purchase requests using specialised software, organising and maintaining correspondence, supervising the internal reports library and its electronic archive, executing bilingual translations and general duties assisting technical work.

5.5.5 MAINTENANCE OPERATIONS

	Daily staff on work						Staff ramping-up					
	PAR	ARM	GAR	Total	turno factor	Total FTE	2019	2020	2021	2022	2023	
Maintenance operations												
Mechanical engineers	0.00	6.00	0.00	6.00	2.5	15.00	0.00	0.20	0.20	6.00	6.00	
Mechanical technicians	3.00	7.00	0.00	10.00	2.5	25.00	0.00	0.20	0.20	10.00	10.00	
Electrical engineers	2.00	1.00	0.00	3.00	2.5	7.50	0.00	0.00	0.00	3.00	3.00	
Electrical technicians	3.00	1.00	0.00	4.00	2.5	10.00	0.00	0.00	0.00	4.00	4.00	
Electronic technicians	0.00	2.00	0.00	2.00	2.5	5.00	0.00	0.20	0.20	2.00	2.00	
Administrative assistant	0.50	0.00	0.00	0.50	1.0	0.50	0.00	0.00	0.00	0.25	0.50	
Maintenance operations Total	8.50	17.00	0.00	25.50	-	63.00	0.00	0.60	0.60	25.25	25.50	

Table 5.7. Planning of staff on daily work.

	Daily staff on work						Staff ramping-up (turno applied)				
	PAR	ARM	GAR	Total	turno factor	Total FTE	2019	2020	2021	2022	2023
Maintenance operations											
Mechanical engineers	0.00	6.00		6.00	2.5	15.00	0.00	0.50	0.50	15.00	15.00
Mechanical technicians	3.00	7.00		10.00	2.5	25.00	0.00	0.50	0.50	25.00	25.00
Electrical engineers	2.00	1.00		3.00	2.5	7.50	0.00	0.00	0.00	7.50	7.50
Electrical technicians	3.00	1.00		4.00	2.5	10.00	0.00	0.00	0.00	10.00	10.00
Electronic technicians		2.00		2.00	2.5	5.00	0.00	0.50	0.50	5.00	5.00
Administrative assistant	0.50			0.50	1.0	0.50	0.00	0.00	0.00	0.25	0.50
Maintenance operations Total	8.50	17.00	0.00	25.50	-	63.00	0.00	1.50	1.50	62.75	63.00

Table 5.8. Planning of positions after application of shift/turno factor (FTEs).

- *Mechanical engineers*: One will also be the Head of this Department and will organise the department to execute on time all the planned maintenance tasks. He/she will also be in charge of identifying failure risks, key indicators, and intervention time to optimise and minimise the resources need. The mechanical engineers will carry out on-field mechanic and optomechanical maintenance tasks, maintaining, fine-tuning and improving the mechanical systems of the telescope, instruments and facilities (air compressors, chillers, etc.), which include hydraulic- and pneumatic systems, electro-mechanical mechanisms and drives. Mechanical engineers are also required to maintain the co-generation facilities for heating and hot water as well as to call in off-site support contractors when required.
- *Mechanical technicians* will provide technical support for the maintenance of the telescope, keeping the performance and availability of the telescope systems on the highest level. They will have experience in mechanical and hydraulic systems with either a university or a technical institute degree. Experience in production plants or technical service companies is also required. Capabilities in the following fields are required: advanced hydraulic and pneumatic, precision mechanics, tribology and lubrication, welding, tool machining, metrology, failure analysis and basic knowledge of electricity and control. Basic PC computer literacy in word processing and spreadsheets.
- *Electrical technicians*: The minimum qualifications for these posts should be either a technical university or a superior technical degree or alternatively at least eight years of relevant experience in working with advanced electrical equipment.
- *Electronic technicians* will be required to service and troubleshoot digital and analogue electronics equipment, be responsible for the maintenance, adjusting, troubleshooting and monitoring of scientific/astronomical equipment, to perform general electronics work associated with cabling and connection, and to procure electronics equipment and components. They will have either a technical university or a superior technical degree or alternatively at least five years of relevant experience in working with electronics equipment.
- *Administrator/Planner for the CMMS* is responsible for preparing the schedule of the daily tasks for each member of the maintenance department, taking into account preventive, predictive and other maintenance needs. He/she will be familiar with the CMMS tool and the software tools to control the spare parts needs and availability on site to execute the maintenance tasks.

5.5.6 LOGISTICS OPERATIONS

	Daily staff on work						Staff ramping-up					
	PAR	ARM	GAR	Total	turno factor	Total FTE	2019	2020	2021	2022	2023	
Logistics												
Procurement officer	1.0	0.0	0.0	1.0	1.0	1.0	0.0	0.0	0.0	0.5	1.0	
Controller	1.0	0.0	0.0	1.0	1.0	1.0	0.0	0.0	0.0	0.5	1.0	
Board & Lodging Manager	0.5	0.0	0.0	0.5	2.5	1.3	0.0	0.0	0.0	0.5	0.5	
Transport Manager	1.0	0.0	0.0	1.0	2.5	2.5	0.0	0.0	0.0	1.0	1.0	
Administrative assistant	1.0	0.0	0.0	1.0	2.5	2.5	0.0	0.0	0.0	0.5	1.0	
Logistics Total	4.5	0.0	0.0	4.5	-	8.3	0.0	0.0	0.0	3.0	4.5	

Table 5.9. Planning of staff on daily work.

	Daily staff on work						Staff ramping-up (turno applied)					
	PAR	ARM	GAR	Total	turno factor	Total FTE	2019	2020	2021	2022	2023	
Logistics												
Procurement officer	1.00			1.00	1.0	1.00	0.00	0.00	0.00	0.50	1.00	
Controller	1.00			1.00	1.0	1.00	0.00	0.00	0.00	0.50	1.00	
Board & Lodging Manager	0.50			0.50	2.5	1.25	0.00	0.00	0.00	1.25	1.25	
Transport Manager	1.00			1.00	2.5	2.50	0.00	0.00	0.00	2.50	2.50	
Administrative assistant	1.00			1.00	2.5	2.50	0.00	0.00	0.00	1.25	2.50	
Logistics Total	4.50	0.00	0.00	4.50	-	8.25	0.00	0.00	0.00	6.00	8.25	

Table 5.10. Planning of positions after application of shift/turno factor (FTEs).

The logistics staffing is based on an extensive use of contractors. ESO positions are justified on the basis of either the supervisory nature, or their critical nature for essential services and operations. The services cover on-site procurement, financial controller, board and lodging, transport and administrative assistance.

5.5.7 OFF-SITE DEVELOPMENT AND MAINTENANCE

	Daily staff on work					turno factor	Total FTE	Staff ramping-up				
	PAR	ARM	GAR	Total	2019			2020	2021	2022	2023	
Off-site development & support												
Various technical disciplines			6.0	6.0	1.0	6.0	0.0	0.0	0.0	3.0	6.0	
Off-site development & support	0.0	0.0	6.0	6.0	-	6.0	0.0	0.0	0.0	3.0	6.0	

Table 5.11. Planning of positions after application of shift/turno factor (FTEs).

Staff from Garching will be allocated to support E-ELT operations as for the VLT operations. Telescope, instrumentation, technology software development will be covered. The involvement of DMO staff is accounted for separately under off-site operations support.

5.5.8 UPGRADE PATHS (NEW SYSTEMS)

	Daily staff on work					turno factor	Total FTE	Staff ramping-up				
	PAR	ARM	GAR	Total	2019			2020	2021	2022	2023	
Upgrade paths (new systems)												
Various technical disciplines			12.0	12.0	1.0	12.0	6.0	8.0	8.0	10.0	12.0	
Upgrade paths Total	0.0	0.0	12.0	12.0	-	12.0	6.0	8.0	8.0	10.0	12.0	

Table 5.12. Planning of positions after application of turno factor (FTEs).

The implementation of new systems and upgrades to existing ones will follow the same planning, approval and development procedures as applied to E-ELT construction. Telescope, Instrumentation, Technology, Software Development and DMO Divisions will be involved.

5.5.9 STAFF SUMMARY

The following two tables give an overview of the staff needed for the E-ELT operations for each main activity group.

	Daily staff on work						Daily staff on work ramping-up					
	PAR	ARM	GAR	Total	turno factor	Total FTE	2019	2020	2021	2022	2023	
Operations staff staff												
Director's Office total	3.00	0.50	0.00	3.50	-	5.75	0.00	0.00	0.00	1.75	3.50	
Science operations total on-site	4.50	0.00	0.00	4.50	-	13.25	0.00	0.00	0.00	4.50	4.50	
Technical operations	3.00	18.00	0.00	21.00	-	51.00	0.40	0.60	3.20	20.50	21.00	
Maintenance operations	8.50	17.00	0.00	25.50	-	63.00	0.00	0.60	0.60	25.25	25.50	
Logistics total	4.50	0.00	0.00	4.50	-	8.25	0.00	0.00	0.00	3.00	4.50	
On-site operations staff Total	23.50	35.50	0.00	59.00	-	141.25	0.40	1.20	3.80	55.00	59.00	
Science operations total off-site	0.00	0.00	7.50	7.50		7.50	0.00	0.00	0.00	6.50	7.50	
Off-site development & support	0.00	0.00	6.00	6.00	-	6.00	0.00	0.00	0.00	3.00	6.00	
Upgrade paths (new systems)	0.00	0.00	12.00	12.00	-	12.00	6.00	8.00	8.00	10.00	12.00	
Off-site operations staff Total	0.00	0.00	25.50	25.50		25.50	6.00	8.00	8.00	19.50	25.50	
Operations staff staff Total	23.50	35.50	25.50	84.50	-	166.75	6.40	9.20	11.80	74.50	84.50	

Table 5.13. Planning of staff on daily work.

	Daily staff on work						Staff ramping-up (turno applied)				
	PAR	ARM	GAR	Total	turno factor	Total FTE	2019	2020	2021	2022	2023
Operations staff staff											
Director's Office	3.00	0.50	0.00	3.50	-	5.75	0.00	0.00	0.00	2.88	5.75
Science operations on-site	4.50	0.00	0.00	4.50	-	13.25	0.00	0.00	0.00	13.25	13.25
Technical operations	3.00	18.00	0.00	21.00	-	51.00	1.00	1.50	8.00	50.50	51.00
Maintenance operations	8.50	17.00	0.00	25.50	-	63.00	0.00	1.50	1.50	62.75	63.00
Logistics	4.50	0.00	0.00	4.50	-	8.25	0.00	0.00	0.00	6.00	8.25
On-site operations staff Total	23.50	35.50	0.00	59.00	-	141.25	1.00	3.00	9.50	135.38	141.25
Science operations off-site	0.00	0.00	7.50	7.50		7.50	0.00	0.00	0.00	6.50	7.50
Off-site development & support	0.00	0.00	6.00	6.00	-	6.00	0.00	0.00	0.00	3.00	6.00
Upgrade paths (new systems)	0.00	0.00	12.00	12.00	-	12.00	6.00	8.00	8.00	10.00	12.00
Off-site operations staff Total	0.00	0.00	25.50	25.50		25.50	6.00	8.00	8.00	19.50	25.50
Operations staff staff Total	23.50	35.50	25.50	84.50	-	166.75	7.00	11.00	17.50	154.88	166.75

Table 5.14. Planning of positions after application of shift/turno factor (FTEs).

Table 5.13 and Table 5.14 give an overview of the staff categories planned for the E-ELT operations. Table 5.14 presents the total operation staff, including the upgrade path.

5.5.10 CONTRACTORS

Service contracts will complement the operation in all operations areas where this option is deemed to offer advantages over staffing with ESO employees.

6 ECONOMIC IMPACT

6.1 INTRODUCTION

It has always been the case that the next generation of astronomy facilities is demanding, both technically and in its need of resources. Once the current generation is approaching the limits of its discovery space, it is inevitable that major progress can only be made by opening a new observation window, perhaps by moving to new wavebands only accessible in space, or by step changes in angular resolution and sensitivity by building larger aperture telescopes or bigger interferometric arrays. The E-ELT is no exception, and it is important to show that such expenditure can be justified not only in the search for knowledge, but for wider societal and economic benefits. These benefits can range from direct industrial contracts, to development of new technology that can be used by other fields and to the less tangible, but perhaps most important, inspiration of new generations of engineers and scientists.

The E-ELT will be the biggest optical/infrared telescope in the world. It will have enormous impact by enabling astronomers to probe and understand a whole range of phenomena from planets around nearby stars (perhaps including planets where life may exist) to the most distant faint galaxies at the edge of the observable Universe. Astronomy and the wonder of space are particularly appealing to the general public and, as such, the E-ELT will be a beacon of inspiration for the next generation, leading to careers in science, engineering and technology. The E-ELT will also have direct economic benefit to Europe in terms of contracts to industry, commerce and research institutes. In phase B this already totals about 40 M€ and it is expected to exceed 860 M€ by the end of the programme. Less predictable, but nonetheless concrete, economic benefits will accrue from capability building in industry, particularly for precision optical surfaces, and from the innovations needed to meet the technology targets presented by this project.

While hard to quantify, such economic benefits are expected to be many times the value of direct contracts. For example, key technologies being developed for big telescopes are associated with their adaptive optics systems needed to correct for turbulence in the atmosphere. These advancements and innovations are already being applied to solve a variety of important problems across many sectors, including enhancing the longevity of artificial knee joints, assisting in the diagnosis of vascular diseases of the eye, improving the performance of industrial lasers, and laser fusion research.

A highly tangible outcome from building this giant telescope will be a cohort of highly accomplished engineers and scientists (with skills honed on this great challenge) that will be capable of applying their talents to a broad range of areas, of great benefit to the Member State economies and societies.

6.2 THE INTERACTION BETWEEN ASTRONOMY, INDUSTRY AND INNOVATION

Right from the beginnings of astronomical telescopes in 1609 there has been a strong connection between industry and advances in astronomical instrumentation. Lipperhey's adoption of technology from the Dutch spectacle industry led directly to the telescopes that enabled Galileo to make his breakthrough observations of the moons of Jupiter. Later, the favour was returned when the astronomer George Airy used his knowledge of optics as applied to astronomy to develop spectacle lenses to provide astigmatism correction, in this case diagnosed in his own eyes. Another breakthrough in astronomical telescope technology came from the German chemical industry when Justus von Liebig developed new methods of deposition of silver, which were used by Leon Foucault in his pioneering silvered-glass telescope in Marseille. This technology soon overtook metal mirrors, becoming the dominant technology for research telescopes and is still used today.

The next great advance in telescope technology again came from the adoption of technology from an industrial field. The great telescopes of the first half of the 20th century used nautical engineering techniques developed to build Dreadnought battleships. The heavy but precise engineering needed to build giant gun turrets was applied to the precision tracking and stiff structures required for large telescopes,

reaching a pinnacle in the 200-inch Hale telescope in 1949, not to be surpassed until the invention of active optics by Ray Wilson of ESO in the late 1980s.

The process of bringing novel technology into astronomy from industry, perfecting it in pursuit of demanding astronomical requirements and then pushing improved technology back into other industrial and research sectors can be regarded as a cycle of innovation.

6.3 IMPACT

It is clear that a project of the size and technological challenge of the E-ELT will have significant economic, cultural and scientific impact; predicting that impact is more difficult. The current state of research into the impact of major science projects is patchy and, of course, any sort of quantitative prediction is problematic. Indeed, it is very difficult to understand the effect of past investments, let alone predict future impact. Two important contributing factors are the importance of serendipitous discovery and the time taken between fundamental discoveries and exploitation. For example, no one would argue that the discovery of the electron was motivated by the need to develop computers. However, we can make some predictions of the potential impact.

Economic impact can be defined as:

An action or activity has an economic impact when it affects the welfare of consumers, the profits of firms and/or the revenue of government. Economic impacts range from those that are readily quantifiable, in terms of greater wealth, cheaper prices and more revenue, to those less easily quantifiable, such as effects on the environment, public health and quality of life.

Hence the impact of research can be both tangible and intangible and can be experienced by the general public, industry and government in addition to those communities directly associated with the research. Economic impact can happen over varying timescales with some research taking ten or twenty years to yield tangible returns.

Impact can be both direct and indirect, with visibility at regional, national and international levels, the latter being particularly true with multinational large-scale facilities. A familiar example is the now all-pervasive laser, which came from fundamental research on microwave oscillators, including natural molecular oscillators in space, and for many years was regarded as “a solution looking for a problem”.

6.3.1 CATEGORIES OF IMPACT

The E-ELT will generate impact in the broadest sense of the word in the following categories:

- Generating knowledge: understanding the Universe and our place in it;
- Providing inspiration: the cultural and symbolic impact of doing inspirational science, essential for attracting the next generation into careers in science, technology and engineering;
- Increasing the skills base: for scientific and technological problem-solving, especially development of trained graduates;
- Building industrial capacity: creating new firms, and attracting inward investment;
- Stimulating innovation: development of technologies which can ultimately lead to new goods and services; and
- Improving the quality of life: through new technologies that address the grand challenges of the 21st century.

6.4 GENERATING KNOWLEDGE

The E-ELT will expand our knowledge of the Universe. It will have a major impact, all the way from the earliest phases of star and galaxy formation as the first light was generated, to studies of exoplanets around nearby stars. While the E-ELT pushes towards these grand aims, it will also generate significant knowledge of benefit to industry and other sectors of science.

6.5 PROVIDING INSPIRATION

A recent study of how to attract young people to careers in engineering stated:

Young people will be impressed if we can demonstrate the crucial role engineers play on big, iconic projects; they add glamour, longevity, respect and fame to engineering. It also added that, currently, there is little aspiration or allure attached to engineering, but that this could be enhanced. This is certainly an area where the E-ELT can contribute with high impact.

6.6 INCREASING THE SKILLS BASE

Developing and using the E-ELT is a major endeavour in science, technology and engineering. Partnerships between institutes, university groups and industry are already forming to build and exploit this telescope, its systems and instruments. A major impact of this will be to develop a cohort of trained scientists and engineers with skills and knowhow honed by the challenges of this huge and complex machine. Hundreds of scientists and engineers will be employed on the project in the Member States. These will include new graduates and post-docs who will transfer these skills to future challenges across a range of disciplines. These skills are applicable to many of the grand challenges of the 21st century.

Therefore, the process of designing, constructing, operating and exploiting the facility will create large numbers of highly trained people. In a recent survey of UK graduates from 2000 to 2003, half were currently employed in the public (non-university) or private sectors with roles spanning a broad range, including government posts, teaching, financial services, manufacturing, communications, and the defence industry.

6.7 BUILDING INDUSTRIAL CAPACITY

The E-ELT programme will invest some 820 M€ in industry. In line with ESO's procurement policy, the bulk of this investment will be made in the Member States and Chile. These contracts will not only stimulate Member State industry, but could also place the same industries in a prime position for other future contracts for other sectors, such as laser fusion, ultra-precision optics for lithography in semiconductor manufacture, and Earth observation systems.

The E-ELT programme will also generate commercialisation opportunities. For example, there are potential spin-out opportunities in the fields of laser technology, dental care, medical imaging and turbulence monitoring. There have already been several spin-out companies from astronomy technology.

The emergence of new companies, both in response to the procurement requirements of the facility and from technology spin-offs, are expected to be a key impact of the E-ELT. The value of these new industries and companies to the Member State economies cannot be predicted accurately, but it is possible to sketch a perspective on potential economic return. A recent market study suggests that the world market for adaptive optics in biomedical and communications applications could potentially grow to over 500 M€ per year within ten years. Detector developments, currently funded to provide better optical and infrared detectors for E-ELT instruments and adaptive optics systems, could also expand this market by several hundred million euro per year. An even larger potential market would be opened up if laser fusion is successful as a new energy generation technology. The development of systems like the HiPER laser fusion concept and its successors could provide market opportunities in the range of hundreds of billions of euros.

6.8 STIMULATING INNOVATION

Some examples of potential cycles of innovation that could take place during development of the E-ELT and its instruments and systems follow.

6.8.1 ADAPTIVE OPTICS

The success of the E-ELT is dependent on development of adaptive optics technologies and systems with challenging requirements. Adaptive optics is being increasingly applied to biomedical imaging such as the diagnosis of vascular disease in the eye, optical communications, security, and laser systems.

6.8.2 DETECTORS

The E-ELT is pushing the requirements on sensitivity, pixel count and speed. High-performance optical and infrared detectors have wide-ranging applications outside astronomy, especially in biomedical imaging and security scanning.

6.8.3 LARGE PRECISION OPTICS

The E-ELT primary mirror requires almost one thousand precision segments (including spares), pushing the development of rapid production and metrology techniques. Such large optical elements have applications in, for instance, laser fusion research. The novel techniques being developed to enable us to make over a thousand primary mirror segments at reasonable cost would be needed to manufacture mirrors to focus terawatt lasers on to pellets of deuterium and tritium to bring about fusion (creating helium, neutrons and huge amounts of energy). These high-power lasers cause damage to the optical surfaces, with the consequent need for routine replacement, implying a need for economic mass production of precision mirrors. The very same grinding machines being developed for the manufacture of E-ELT mirror segments result in low subsurface damage and hence potentially lower susceptibility to laser damage. Of course, there are many problems to be solved before laser fusion could be regarded as a practical power source, but a series of test facilities are now being built and planned (e.g., National Ignition Facility, Laser Megajoule, HiPER) that could result in zero carbon emission power generation within the next fifty years. If this were to come about, the raw material requirements are impressive. Deuterium can be extracted from seawater, and tritium bred from natural lithium. A lifetime of electricity for one person at the levels of consumption by western economies would only require a bath-full of sea water and the lithium used in one laptop battery.

Another application of precision surface-forming is the manufacture of artificial knee joints, where joint lifetime can be enhanced by using a hard-on-hard bearing combination that requires improved surface finish. The need to keep up with Moore's law is also pushing semiconductor lithography towards shorter wavelengths and hence higher-precision optical surfaces.

6.8.4 INSTRUMENTATION

The E-ELT needs large, complex optical/infrared instruments, involving challenges in materials, mechanisms, cryogenics and optical components. These are generic technologies, with application in a wide range of scientific instrumentation, from Earth observation satellites to infrared spectroscopy for medical diagnostics.

6.8.5 PHOTONICS

Adoption in future instruments of photonic technologies from the telecommunications industry will cycle innovation back into industrial, environmental and biomedical applications.

6.8.6 IMAGE AND DATA PROCESSING

Challenging requirements for the extraction of information from noisy and complex images stimulates development of new techniques, which are being applied to biomedical imaging applications such as histopathology and magnetic resonance imaging (MRI) scanning.

6.8.7 STRUCTURAL ENGINEERING

The E-ELT is a massive smart structure with precise alignment requirements. Lessons learned could be applied to many high-precision, active structures, including laser fusion systems.

6.8.8 IMPROVING THE QUALITY OF LIFE

Many of the most direct impacts on quality of life derived from astronomy and its enabling technology have been mentioned in other contexts above. Technologies from optical and infrared astronomy are already being applied to medicine and the life sciences, and the new technology we are developing for

the E-ELT is likely to have even more impact. For instance, retinal imaging to help diagnose macular degeneration, wavefront sensing to enable design of more accurate interocular lens implants, and medical data analysis for interpretation of brain scans. Lightweight and controllable optical surfaces can be applied to several areas which could have impact on the environment and our carbon footprint, from understanding climate change through Earth observation systems, to reducing carbon emissions through the use of solar power and, ultimately, laser fusion systems.

7 OUTREACH AND EDUCATION

7.1 THE VALUE OF RESEARCH INFRASTRUCTURES FOR SOCIETY

Beyond the obvious benefits for scientific research and for the economy, large-scale research infrastructures such as the E-ELT also have an important added value for society. This added value can be divided into three broad areas: large-scale facilities can have a *social mission*; they can contribute to *social innovation*; and they play an essential role *in informing and educating the wider public*.

Regarding the first aspect: the social mission of a facility can be one that seeks an immediate impact (e.g., numerous examples exist in the biomedical domain) or one that aims at a long-lasting impact on society. The E-ELT is a prime example for the latter: it is one of the, if not *the*, first facility that could detect life beyond the Solar System if it exists. With the potential of such a discovery, the E-ELT could have a most profound impact on society. The answer to the question “Are we alone?” is one that has fascinated humanity for centuries. An answer does not only have deep philosophical implications, but also religious ones. The potential discovery of life on an exoplanet would profoundly and permanently change the perception of our place in the Universe.

While the above impact on society is as uncertain as it would be profound, large-scale facilities have routinely had a much more immediate impact on social innovation. The most famous example is certainly the introduction of the world wide web in 1991 at CERN — whose impact on the innovation of society does not need to be expanded on. The history of science is filled with other more or less prominent examples (e.g., the world’s first cyclotron in Berkeley in the 1930s which led to today’s common radioactive pharmaceuticals; or the recent Grid computing at CERN’s Large Hadron Collider that launched the era of “cloud computing”). The E-ELT project is innovative in many technologies (optics, electronics, communication) and pushes European industry to the technological limit, requiring creativity and exploration. It is thus expected that the technological developments in the ESO Member States and/or the E-ELT itself will generate a number of byproducts that will all contribute to innovation in our society.

Arguably the most important impact of large-scale research infrastructures is their role of informing and educating the wider public. Major scientific projects appeal to people’s imagination. They are ideal platforms to publicise science and its benefit to society. Astronomy plays a leading role in this endeavour as it easily conveys the beauty and mystery of science through the fantastic images of the Universe surrounding us. The E-ELT will provide images fifteen times sharper than those from the NASA/ESA Hubble Space Telescope — it is easy to picture their effect on the public when looking back at the transformational role that the HST has played in the perception of the night sky. The E-ELT will undoubtedly draw the public’s attention to science.

The role and added value of large-scale research facilities, with emphasis on their value to society, were recently studied by the Taskforce to Promote Large-Scale Research Facilities and by the Dutch Ministry of Education, Culture and Science. The key results on the social effects of large-scale research facilities are summarised in Figure 7.1, taken from their final report^{†††} (Feb. 2011).

^{†††}http://www.technopolis-group.com/resources/downloads/reports/1379_Report_Large-scale_Research_Facilities_EN.pdf

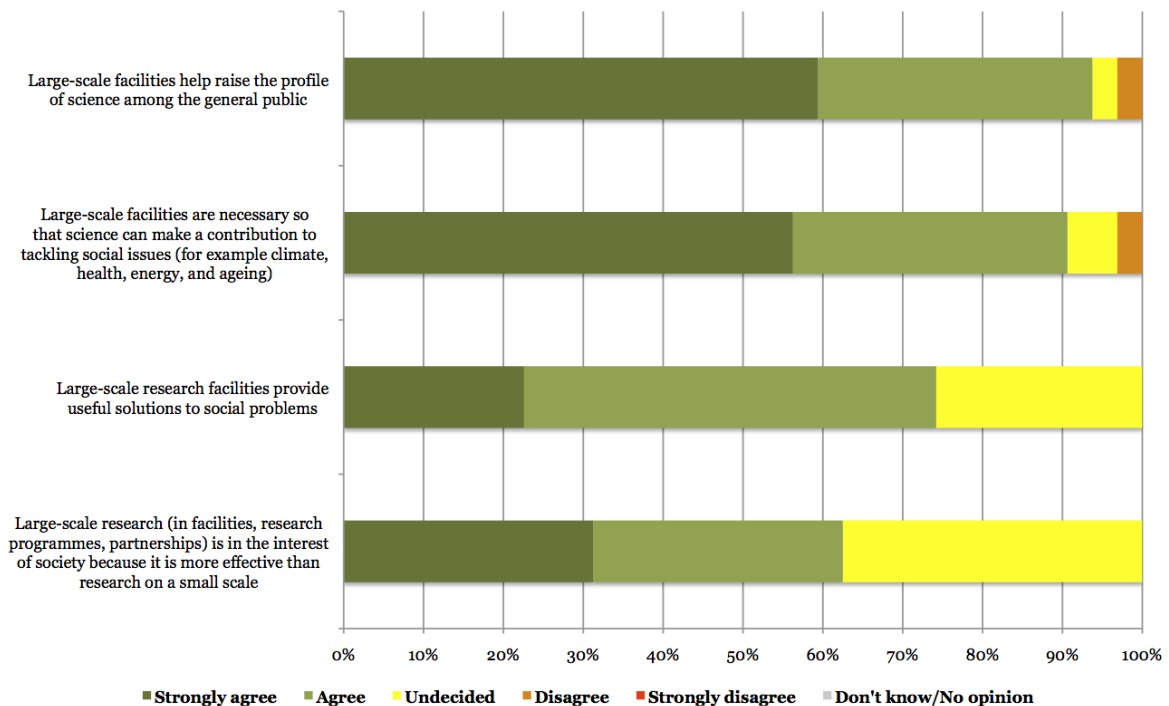

Figure 7.1. The social effects of large-scale research facilities. Source: Web Survey of Large-Scale Research Facilities, Technopolis Group (2010).

7.2 THE IMPACT OF THE E-ELT ON EDUCATION AND PUBLIC OUTREACH

The need to intensify science information to and education of the public, in particular of the young people in Europe, is recognised in all Member States.

The 2007 report⁺⁺⁺ to the European Commission on Science Education states: *“In recent years, many studies have highlighted an alarming decline in young people’s interest for key science studies and mathematics. Despite the numerous projects and actions that are being implemented to reverse this trend, the signs of improvement are still modest. Unless more effective action is taken, Europe’s longer-term capacity to innovate, and the quality of its research will also decline. Furthermore, among the population in general, the acquisition of skills that are becoming essential in all walks of life, in a society increasingly dependent on the use of knowledge, is also under increasing threat.”*

As outlined above, large-scale facilities such as the E-ELT represent unique opportunities to reach out to the public, to inform and generate enthusiasm amongst young people for science through astronomy and to help reverse the trend of a declining interest. With its strong multidisciplinary character and powerful public appeal, astronomy can play an important role in modern science education. The stunning scientific results from ESO’s telescopes already provide invaluable treasures for science teachers.

⁺⁺⁺http://ec.europa.eu/research/science-society/document_library/pdf_06/report-rocard-on-science-education_en.pdf

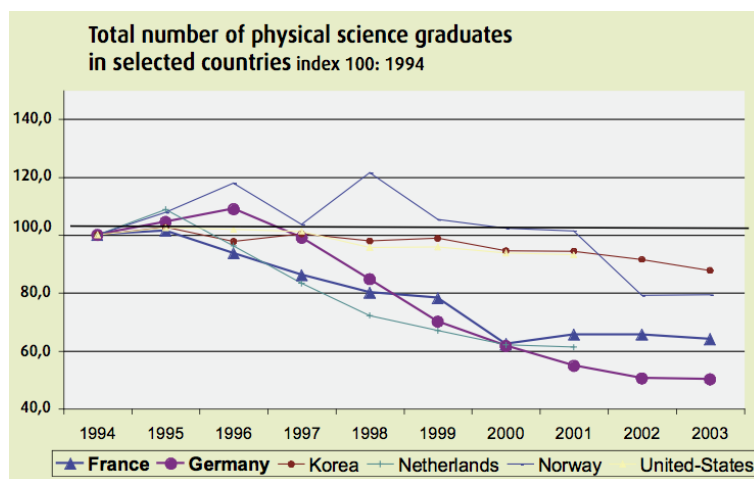

Figure 7.2. Total number of physical science graduates in selected countries. Source: Science Education NOW – see above link to the full report.

7.2.1 ESO'S EDUCATION AND OUTREACH PROGRAMME

Astronomical discoveries in general, especially those that will arise from the E-ELT will be a tremendous tool for increasing the general public's interest in science, by showing often quite dramatic wonders of the Universe through "pretty pictures" and videos.

The E-ELT outreach activities are carried out by the ESO education and Public Outreach Department (ePOD). As part of the Department, European outreach for the NASA/ESA Hubble Space Telescope provides comprehensive information about this telescope and its scientific discoveries. Also the International Astronomical Union (IAU) Press Office is hosted at ESO as part of the Department. The E-ELT education and outreach activities are integrated into the programme alongside the existing observatories and telescopes: La Silla, VLT, the survey telescopes and ALMA.

A wide range of programmes and activities are used to meet the specific requirements of television, print and online media, such as press releases and broadcast material for the media. ePOD embraces a multimedia approach to public outreach, as seen in, for example, the ESOcast, the Hubblecast, social media etc. ePOD produces high-quality printed material such as brochures, books, annual reports, newsletters (*The Messenger*, *CAPjournal*) posters, etc.

ePOD publishes around 50 press releases per year for ESO, and over 25 press releases for ESA/HST, and the IAU combined. ESO also issues over 100 announcements per year for smaller, but still news-worthy stories.

In the past, some impressive events have been covered by the department, such VLT First Light, Astronomy On-line, and the impact of Comet Shoemaker-Levy 9. Some famous educational campaigns such as Venus Transit, Science on Stage and Science in School have also come out of the department.

ePOD also organises exhibitions in science museums and planetariums, as they are amongst the best conduits for disseminating astronomy more widely to the interested public. ESO has produced two planetarium shows so far. The first was focused on the ESO observatories in Chile and is entitled *Mysteries of the Southern Sky*. It was released in 2002 in five languages and has been aired in about 40 locations in seven European countries and in the USA. The second, in full-dome format with extensive 3D animations, is entitled *In search of our Cosmic Origins* and was released in 2009. It is available in at least eight languages and has been shown in more than 65 planetariums. Its story revolves around the ALMA facility.

Other interactions with science museums and the general public involve the (co-)organisation of more than 60 annual events and exhibitions in which ESO continues to be involved. Exhibition panels and exhibition models of the E-ELT have been produced, some of which are on long-term loan to science centres in Europe. For example, ESO's participation in a new "Universe Space" at the Deutsches

Museum in Munich means that the E-ELT is extensively featured there, along with the science it will address. Print material has also been produced, and has been distributed to science centres and planetariums worldwide, as well as to the public during exhibitions.

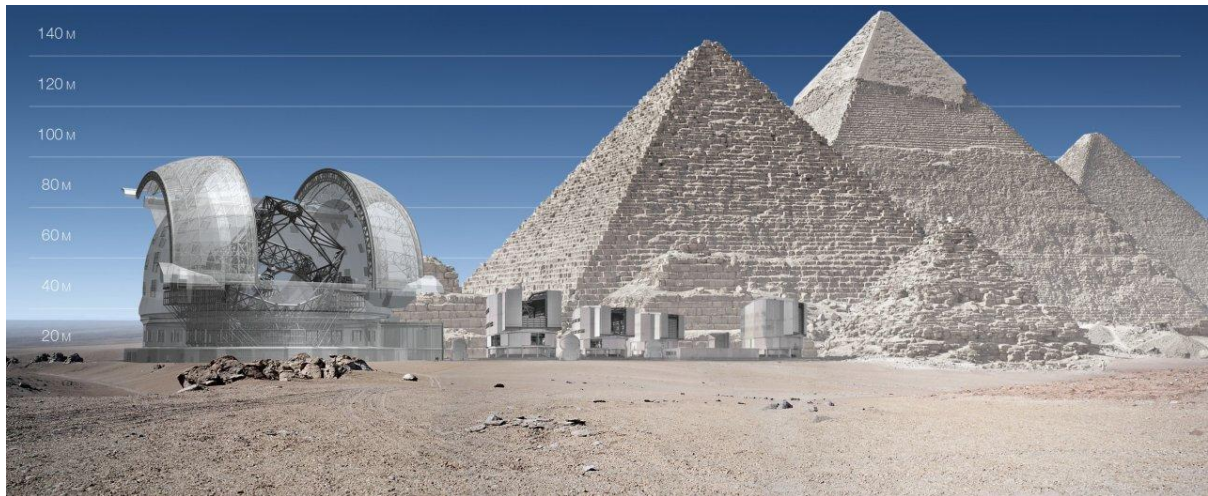

Figure 7.3. The E-ELT compared with the Pyramids.

A large collection of photos (5000+) and videos (1500+) can be found in the ESO Public Image Gallery, including footage in uncompressed HD quality, directly usable for broadcasting.

ESO's presence on the internet is massive and still increasing. The number of visits to the eso.org site exceeded three million per year in 2010.

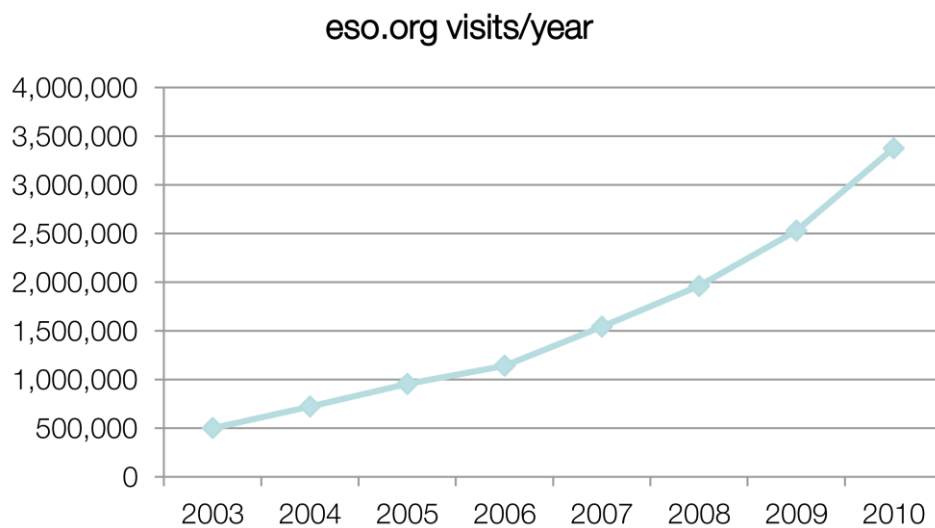

Figure 7.4 Visits per year on the ESO website.

The ESO Science Outreach Network (ESON) translates ESO news and background information into 19 different languages and publishes it on 27 different mini-sites. In addition to providing the translations, the ESON representatives serve as local contacts for the media and the general public in connection with ESO developments, press releases, exhibitions etc. They promote ESO in various ways in the Member States and add significantly to the visibility of the organisation.

7.2.1.1 ESO'S EDUCATION PROGRAMME

Astronomy is often little taught at secondary schools in Europe, despite its strong educational value and its fascination for the youngest, and not so young minds, for the astronomy/space domain. It is widely recognised that the key action lies in offering ever more astronomy-related training courses for teachers

including practical observations, modern topics and examples. This global issue is essentially in the hands of the Ministries of Education in the European states or regions, but it is important that ESO remains involved on a regular basis in that area.

ESO supports astronomy and astrophysics education, especially at the high-school level. This includes teaching materials, courses for teachers and specific educational projects, often in collaboration with partners such as the European Association for Astronomy Education (EAAE), the EIROforum, the European Commission and others.

ESO's educational programmes aim to stimulate interest in the natural sciences, and in astronomy and astrophysics in particular, among European youth. With their international dimension, they complement efforts by national education authorities, universities and individual schools and teachers.

These efforts are continued and strengthened through joint EIROforum activities, with programmes such as Life in the Universe and Couldn't be without it! targeting school children, and the Physics on Stage and Science on Stage programmes, which are directed towards European science teachers. With its partners in the EIROforum, ESO also publishes Europe's first international, multidisciplinary journal for science teaching, *Science in School*.

ESO has also been the leading force behind several high-profile educational pilot programmes, often carried out in collaboration with partners including the European Commission, such as The Future Astronomers of Europe, Astronomy On-Line and the Sea & Space projects, all carried out in the framework of the European Science and Technology Weeks.

A list of ESO's previous programmes is available at:
<http://eso.org/public/outreach/eduoff/prev-programmes.html>

Targeting the attention of the young generations, ESO successfully built up a leading presence in social media among astronomy institutions through channels such as Facebook and Twitter.

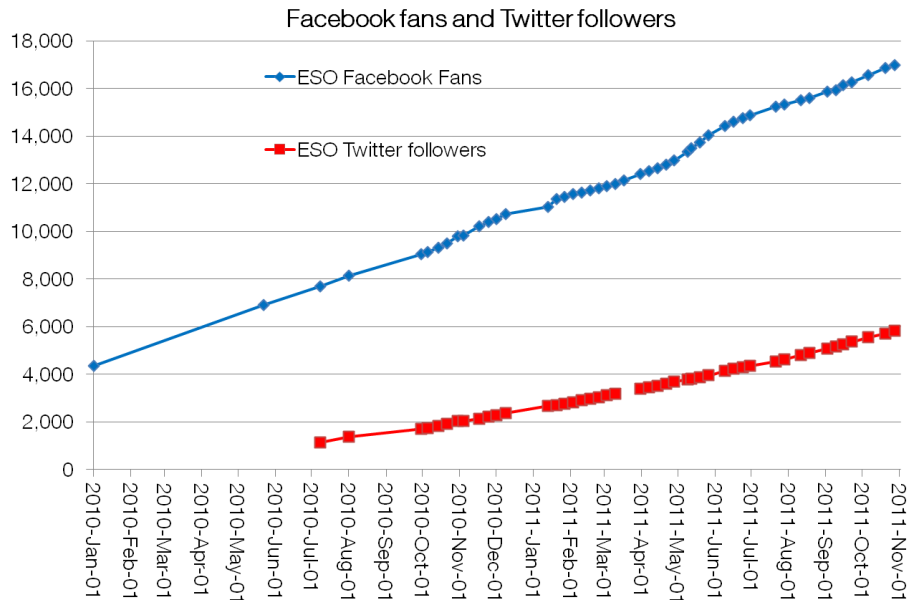

Figure 7.5. Numbers of fans and followers on social media.

7.2.1.2 LOCAL OUTREACH IN CHILE

Initially through the La Silla Observatory, then the Paranal and the ALMA observatories in Northern Chile, we have direct experience on the impact on the outreach and education value of building and operating major astronomical observatories in a host country outside of our direct constituency.

The key aspect has been to forge cultural links at many levels between ESO and Chile. Specific actions include annual funds for the development of astronomy in Chile and more specifically for astronomical, technical and cultural developments in the two regions where the observatories are located. As host country, Chile is in addition getting a significant fraction of telescope time not only on ESO facilities (10%), but at other observatories as well: this hugely increases the appeal of Chilean astronomical departments worldwide, including in other South American countries. Consequently, astronomy departments and curricula have been steadily developed at all major Chilean universities over the last decade. Astronomy has become a major branch of science and a magnet for students at Chilean universities.

But the educational system is not the only thing to profit from the presence of ESO's world-leading telescopes in Chile. The Paranal Observatory now figures in all major travel guides as attraction in the Atacama Desert. The result is an increase in the number of visitors at the site. Through the regular weekend visits, close to 10 000 tourists per year visit the sites. In addition, every year more than 500 VIPs and representatives of the media visit the ESO sites, spread over 200 days throughout the year.

8 MANAGEMENT PLAN

8.1 CONTEXT

The E-ELT project will be executed by ESO and will be based in the ESO Garching Headquarters. In order to successfully deliver a project of this size together with the continuing instrumentation programme for the La Silla Paranal Observatory, and with ALMA nearing completion and starting science operations, ESO has been reorganised to make optimum use of its resources. The E-ELT project will be inside the ELT Division of the Directorate of Programmes. However, many of the staff will be matrixed to the project from other divisions and directorates. In particular, much of the engineering effort will come from the recently created Directorate of Engineering.

ESO will follow a similar procurement philosophy to that it employed to build the VLT, namely to out-source as much as possible at system level. This philosophy has been extended for the E-ELT to reduce risk in the programme through using the Front End Engineering Design process and extensive prototyping of critical components.

8.2 GOVERNANCE

The Directorate of Programmes reports to Council at each ordinary Council meeting about the status of the E-ELT programme.

The report is a Council document that is also submitted twice a year for information and comments to the Finance Committee ordinary meeting that precedes the Council ordinary meeting. The (revised) version which includes the comments from the Finance Committee is sent to Council for information and discussion.

The report, whose financial section is confidential and which is validated by ESO Finance, includes progress reports, significant issues (risks) and financial reports and projections. It is organised according to the work breakdown structure. The schedule report identifies the critical path and any tasks with less than one month of slack. The financial reporting includes the use of ESO manpower, and, explicitly and separately, the usage of contingency funds. Financial reporting follows the ESO accounting rules in force at the time of the report.

The Directorate of Programmes also gives, twice a year, a verbal presentation about the status of the E-ELT programme to the STC and to any subcommittees that the STC deems necessary.

8.3 PROJECT TEAM STRUCTURE AND RESPONSIBILITIES

The E-ELT programme establishes a construction activity (“the project”) managed by a project manager, and other activities that involve interactions with the community, the public etc. that are managed more globally within the Directorate of Programmes. Interfaces with other Divisions and Directorates are addressed in the relevant sections below.

The organisation shown below is designed to provide the project manager with the direct authority necessary to execute the project and support her/him in this role at the scientific and strategic level.

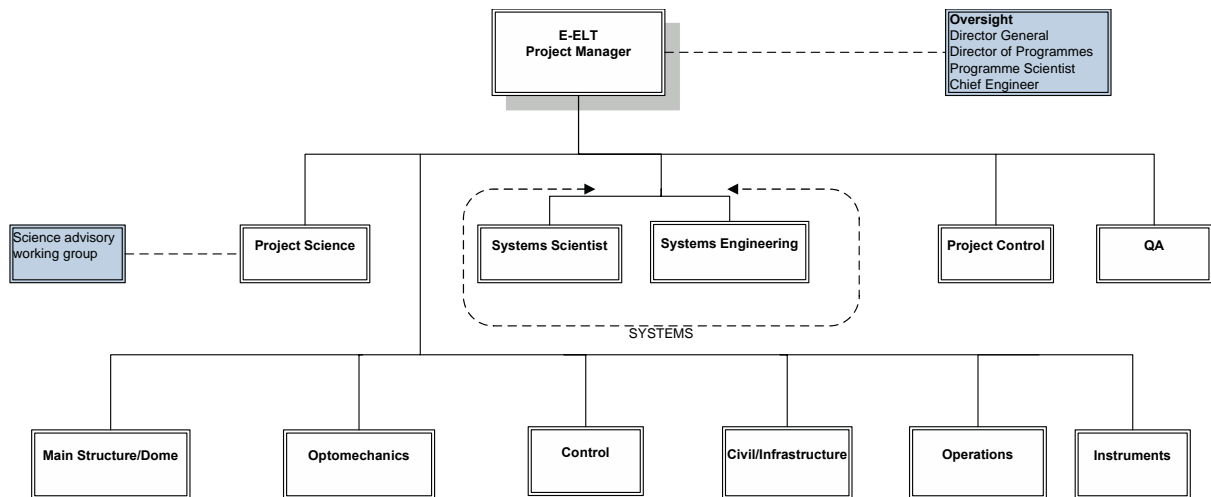

Figure 8.1. The E-ELT project org chart.

8.3.1 DIRECTORS OF PROGRAMMES AND OPERATIONS

The Directorate of Programmes executes the E-ELT programme and the Director, supported by the programme scientist, ensures that the high level scientific aims and strategic goals of the organisation for this programme are met. The Director of Programmes is the line manager for the E-ELT project manager and is the penultimate authority (the ultimate being the Director General) on matters of safety and quality control. The Director of Programmes is supported by ESO general support services in the areas of relations with Chile, human resources and legal advice.

The E-ELT is to be constructed and operated at the La Silla Paranal Observatory. The strategic coordination of the programme needs and the observatory requirements are managed at the level of the Director of Programmes and the Director of Operations, supported by the programme scientist. The detailed implementation is managed at lower levels (see below).

The Director of Programmes is supported in operational oversight of the E-ELT project by the ESO Management Team augmented as necessary by the programme scientist and members of the Directorates of Operations and Engineering.

8.3.2 PROGRAMME SCIENTIST

The programme scientist reports to the Director of Programmes and is responsible for ensuring that the delivered E-ELT is capable of successfully carrying out its scientific aims. The programme scientist is actively involved in all aspects of the design and construction of the E-ELT. Specifically, the programme scientist approves all science-related documentation.

The programme scientist:

- Releases the top-level requirements;
- Owns the science and site operations plans; and
- Is responsible for (supported by ESO general services) outreach and the web presence of the programme.

8.3.3 PROJECT MANAGER

The project manager is responsible for delivering the E-ELT within time, costs and specifications. The project manager reports to the Director of Programmes and is a full member of the ESO Management Team with direct access to the Director General.

The project manager:

- Leads the team and ensures that the resources necessary to execute the project are available;
- Is responsible for reporting on a regular basis on progress, cost and schedule variations and risks;
- Releases all technical and managerial documentation generated within the project;
- Is the sole authority for approving change requests and requests for waiver, irrespective of their origin or urgency;
- Supported by, and in consultation with ESO Finance, submits the annual forecast and man-power request to the Director of Programmes;
- Is supported by ESO general services in the areas of finance, contracting and procurement and logistics; and
- Is the point of contact for interactions with the La Silla Paranal Observatory that are not of strategic nature. In this context the project manager is responsible for ensuring that the disruption of the operations of La Silla Paranal is minimised and the benefits maximised.

8.3.4 PROJECT SCIENTIST

The project scientist reports to the project manager and heads the E-ELT science office that assists in identifying aspects of the telescope, instrumentation or operations that need to be monitored or investigated through simulations and analysis. The project scientist and the members of the science office are matrixed into the E-ELT project from the Directorate of Science. This matrix arrangement also provides the project scientist with a degree of independent reporting to the Director of Science.

The project scientist:

- Chairs the science advisory working group that is populated by members of the astronomical community;
- Interacts closely with the project manager on operational aspects; and
- Owns the top-level requirements document.

8.3.5 SYSTEMS SCIENTIST

The E-ELT systems scientist reports to the project manager and ensures that the science requirements of the project are fully maintained and tracked within the project. He will also ensure that the verification process is developed and maintained to ensure that all requirements can be verified, and that the verification is clearly tracked through the project documentation and DOORS. He will work closely with the project engineer to ensure that this work is coordinated with systems engineering. He will be the scientist responsible for configuration control and sit on the project change control board. The systems scientist will also be responsible for leading the planning of AIV and commissioning.

8.3.6 PROJECT ENGINEER

The E-ELT project engineer reports to the project manager and is responsible for ensuring that the engineering effort utilised on the project is coordinated and that the telescope error budgets, stroke budgets, operational scenarios, interfaces, requirements and configuration are up to date and compatible with the design. The project engineer verifies that all specifications for subsystems are compatible with the overall design of the telescope and meet the requirements. The project engineer leads a team that includes at least one of, a requirements analyst, instrument systems engineer and an interface and configuration manager. The project engineer is responsible for the analysis of the performance of the telescope and instrumentation, the verification of the specifications and the requirements and the development of all ancillary information necessary (e.g., error budgets, operational scenarios etc.).

8.3.7 PROJECT CONTROLLER

The project controller reports to the project manager and pro-actively manages the costs and schedule and risks of the project. The project controller uses earned value tools and sophisticated project planning and tracking tools to continuously update the status of the project and generate the necessary reports for management. The schedule manager reports to the project controller.

The project controller is supported by and supports ESO Finance in ensuring that forecasts as well as current status are correctly reflected in the status of the programme.

8.3.8 ACTIVITY MANAGERS

Activities are defined at level 2 of the work breakdown structure. The activity managers report to the project manager and are responsible for delivering the work in the work-packages that are included in their areas. Six major activities are foreseen as per the structure above (optomechanics, dome and main structure, civil/infrastructure, instrumentation, control system, science data operations). The activity managers follow all contracts in their area and ensure that contracting and scheduling do not conflict. Furthermore, they ensure that the maximum benefit is gained from the streamlining of contracts and solutions. The activity managers enable the coordination of the work such that conflicts that may arise due to overloading of contractors (e.g., access to cranes) or clashes of resources within ESO have the minimum impact.

They manage a team of engineers matrixed into the project from other directorates and divisions of ESO that support the activities in their area. They are supported by the systems engineering team and the project controller. The activity managers coordinate the activities of the ESO engineering teams to prioritise work according to the needs in their area. Activity managers, supported by project control, submit their manpower, cash forecasts and schedules to the project manager according to the ESO budget preparation process.

8.3.9 WORK PACKAGE MANAGERS

Work packages are at level 3 or below of the work breakdown structure.

The work package managers report to the activity managers. They perform the follow-up of industrial or academic contracts for supplies of the E-ELT. They are responsible for the smooth execution of the contracts and the timely reporting. They are assisted technically by the systems engineering team and the activity engineering team and managerially by the project controller. The work package managers, supported by staff from ESO contracts and procurement, attend all progress meetings with the contractors, prepare and support all reviews and act as the technical contact for contracts. They draft the technical specifications and statements of work for all jobs associated with their work.

The work package managers submit manpower, revised forecasts and schedules to the activity managers and project control, according to the ESO budget preparation process.

8.4 DOCUMENTATION

The documentation of the programme follows the E-ELT documentation plan. Specifications, statements of work and interface control documents are generated in accordance with reference documents. Specifications are to be drawn from within the DOORS database. Technical reports and ancillary documentation supporting technical specifications are not classed as specifications.

The DOORS database is structured according to the work breakdown structure thereby assuring the hierarchy and tracking requirements. The usage of DOORS as a requirements management tool assures the verification of the requirements. The validation of the requirements and the links between them is a process that is undertaken on a monthly basis. The reviewing process for documentation validates the requirements. A report is generated by the requirements manager on changes to the database and the links therein and systems engineering validates these changes. Documentation applicable to contracts always takes precedence, for the particular contract, over future or past documentation.

The sole valid source of information is the ESO technical archive. All documents have an owner (typically the author), an approving entity (typically the work package manager) and a releasing entity (typically the project manager). The release of all documents requires, as a minimum, two signatures. Additionally, technical specifications can only be released with the approval of systems engineering (see below) and science-related documents can only be released with the approval of the programme scientist.

Source code and models used to generate data regarding the project are considered to be documentation and will be archived appropriately. Similarly, source code and executable code used in the operation and construction of the E-ELT are also considered documentation and will be archived and managed appropriately.

8.5 WORK BREAKDOWN STRUCTURE

The work breakdown structure includes all deliverables by the project. The WBS is shown schematically below. Level 1 is the E-ELT project and the levels increment below that. The project work breakdown structure is established along product lines and optimised to take into account the location of activities, the minimisation of interfaces and the interactions with the contractors and other parties.

Level 1		Level 2			Level 3		Level 4		
Main Group	Project	Group	Activity Title	Activity	JOB HEADLINE	Dept	JOB	JOB	
ELT Construction	PJ42	ELT PMO	Project Management C	01	PJ42.01.01	Project Management	01	Project Management	5110
ELT Construction	PJ42	ELT PMO	Project Management O	01	PJ42.01.01	Project Management	01	Project Control	5111
ELT Construction	PJ42	ELT PMO	Project Management O	01	PJ42.01.01	Project Management	01	Risk Mgmt	5112
ELT Construction	PJ42	ELT PMO	Project Management O	01	PJ42.01.01	Project Management	01	Project Safety	5113
ELT Construction	PJ42	ELT PMO	Project Management O	01	PJ42.01.01	Project Management	01	Project Assurance	5114
ELT Construction	PJ42	ELT PMO	Project Management C	01	PJ42.01.02	Project Engineer	02	Project Engineer	5120
ELT Construction	PJ42	ELT PMO	Project Management O	01	PJ42.01.02	Project Engineer	02	System Engineering	5121
ELT Construction	PJ42	ELT PMO	Project Management C	01	PJ42.01.03	Project Science	03	Project Science Office	5130
ELT Construction	PJ42	ELT DMS	Dome & Mainstructure	02	PJ42.02.01	D&MS Activity Lead	01	D&MS Activity Lead	5210
ELT Construction	PJ42	ELT DMS	Dome & Mainstructure	02	PJ42.02.02	D&MS Contracts	02	Dome	5221
ELT Construction	PJ42	ELT DMS	Dome & Mainstructure	02	PJ42.02.02	D&MS Contracts	02	Mainstructure	5222
ELT Construction	PJ42	ELT OPTMECH	Optomechanical	03	PJ42.03.01	OptoMech Activity Lead	01	OptoMech Activity Lead	5310
ELT Construction	PJ42	ELT OPTMECH	Optomechanical	03	PJ42.03.02	Mirror Systems	02	M1 Unit	5321
ELT Construction	PJ42	ELT OPTMECH	Optomechanical	03	PJ42.03.02	Mirror Systems	02	M2 Unit	5322
ELT Construction	PJ42	ELT OPTMECH	Optomechanical	03	PJ42.03.02	Mirror Systems	02	M3 Unit	5323
ELT Construction	PJ42	ELT OPTMECH	Optomechanical	03	PJ42.03.02	Mirror Systems	02	M4 Unit	5324
ELT Construction	PJ42	ELT OPTMECH	Optomechanical	03	PJ42.03.02	Mirror Systems	02	M5 Unit	5325
ELT Construction	PJ42	ELT OPTMECH	Optomechanical	03	PJ42.03.03	Subsidiary systems	03	Prefocal Stations	5331
ELT Construction	PJ42	ELT OPTMECH	Optomechanical	03	PJ42.03.03	Subsidiary systems	03	Laser & Laser Projection Subunits	5332
ELT Construction	PJ42	ELT CONTROL	Control	04	PJ42.04.01	Control Activity Lead	01	Control Activity Lead	5410
ELT Construction	PJ42	ELT CONTROL	Control	04	PJ42.04.02	Control Engineering	02	Wavefront Control	5421
ELT Construction	PJ42	ELT CONTROL	Control	04	PJ42.04.02	Control Engineering	02	Telescope Control	5422
ELT Construction	PJ42	ELT CONTROL	Control	04	PJ42.04.02	Control Engineering	02	Metrology	5423
ELT Construction	PJ42	ELT CONTROL	Control	04	PJ42.04.02	Control Engineering	02	Instrumentation Framework	5424
ELT Construction	PJ42	ELT CONTROL	Control	04	PJ42.04.02	Control Engineering	02	Site Monitoring	5425
ELT Construction	PJ42	ELT CIVIL	Civil	05	PJ42.05.01	Civil Activity Lead	01	Civil Activity Lead	5510
ELT Construction	PJ42	ELT CIVIL	Civil	05	PJ42.05.02	Civil Infrastructure	02	Site Preparation	5521
ELT Construction	PJ42	ELT CIVIL	Civil	05	PJ42.05.02	Civil Infrastructure	02	Temporary Infrastructure	5522
ELT Construction	PJ42	ELT CIVIL	Civil	05	PJ42.05.02	Civil Infrastructure	02	Permenant Infrastructure	5523
ELT Construction	PJ42	ELT GEN INFR	General Infrastructure	06	PJ42.06.01	Supporting Systems Activity Lead	01	Supporting Systems Activity Lead	5610
ELT Construction	PJ42	ELT GEN INFR	General Infrastructure	06	PJ42.06.02	Supporting Systems Construction	02	Lifting and Handling	5621
ELT Construction	PJ42	ELT GEN INFR	General Infrastructure	06	PJ42.06.02	Supporting Systems Construction	02	Washing and Coating	5622
ELT Construction	PJ42	ELT GEN INFR	General Infrastructure	06	PJ42.06.02	Supporting Systems Construction	02	Power - GenSet and Dist	5623
ELT Construction	PJ42	ELT GEN INFR	General Infrastructure	06	PJ42.06.02	Supporting Systems Construction	02	Cryo, Air and Chillers	5624
ELT Construction	PJ42	ELT LOGS	Site Logistics	07	PJ42.07.01	Site Logistics	01	Logistics Support	5700
ELT Construction	PJ42	ELT LOGS	Site Logistics	07	PJ42.07.02	Site Logistics	02	Logistics Supplies	5710
ELT Construction	PJ42	ELT LOGS	Site Logistics	07	PJ42.07.02	Site Logistics	02	Logistics Services	5720
ELT Construction	PJ42	ELT AIVC	AIVC	08	PJ42.08.01	AIVC	01	AIV Engineering	5810
ELT Construction	PJ42	ELT AIVC	AIVC	08	PJ42.08.01	AIVC	01	Commissioning	5820
ELT Construction	PJ42	ELT SDO	Science Data Operator	09	PJ42.09.01	Science Data Operations	01	Science Data Operations	5910
ELT Construction	PJ42	ELT INS	Instrumentation	10	PJ42.10.01	Instrumentation Management	01	Instrumentation Management	5010
ELT Construction	PJ42	ELT INS	Instrumentation	10	PJ42.10.02	Instrumentation System Engineeri	02	Instrumentation System Engineeri	5021
ELT Construction	PJ42	ELT INS	Instrumentation	10	PJ42.10.02	Instrumentation System Engineeri	02	Instrument standards & standard	5022
ELT Construction	PJ42	ELT INS	Instrumentation	10	PJ42.10.03	Instrumentation Development	03	Instrument enabling technologies	5031
ELT Construction	PJ42	ELT INS	Instrumentation	10	PJ42.10.03	Instrumentation Development	03	Instrument spec. development	5032
ELT Construction	PJ42	ELT INS	Instrumentation	10	PJ42.10.03	Instrumentation Development	03	Instrumentation Infrastructure	5033
ELT Construction	PJ42	ELT INS	Instrumentation	10	PJ42.10.04	Instruments	04	Instrument 1 Contract	5041
ELT Construction	PJ42	ELT INS	Instrumentation	10	PJ42.10.04	Instruments	04	Instrument 1 ESO	5042
ELT Construction	PJ42	ELT INS	Instrumentation	10	PJ42.10.04	Instruments	04	Instrument 2 Contract	5043
ELT Construction	PJ42	ELT INS	Instrumentation	10	PJ42.10.04	Instruments	04	Instrument 2 ESO	5044
ELT Construction	PJ42	ELT INS	Instrumentation	10	PJ42.10.04	Instruments	04	Instrument 3 Contract	5045
ELT Construction	PJ42	ELT INS	Instrumentation	10	PJ42.10.04	Instruments	04	Instrument 3 ESO	5046
ELT Construction	PJ42	ELT INS	Instrumentation	10	PJ42.10.04	Instruments	04	Instrument 4	5047
ELT Construction	PJ42	ELT INS	Instrumentation	10	PJ42.10.05	Instrumentations Misc	05	Test Camera	5051

Table 8.1. Work breakdown structure.

8.6 WORKFLOW

The workflow of the project is based on a classical development plan with requirements analysis, system design and architecture design completed. The detailed design of the telescope components is well advanced and the construction project is on the final design and construction, verification and validation track. The technical specifications arising from the phase B activities are to be used to procure the final design and construction. The requirements for all specifications are extracted from the DOORS database. In principle no modifications to these specifications are planned unless they generate a cost or schedule saving.

Following ESO procurement procedures, all significant work will be put out to tender and the ESO Finance Committee will approve the awards of contracts. Monthly progress meetings at the supplier's premises take place and the minutes of these meetings are communicated to project management, including contracts and procurement, and systems engineering. Schedule progress and deviations are reported to project control.

All activities generating a component to be installed at the E-ELT, whether internal to ESO or contracted, undergo design reviews. The review structure follows the ESO norms for preliminary design and final design review. In exceptional circumstances, and with the approval of project management, incremental reviews are permitted. Design reviews are organised according to the ESO procedures and definitions. The review board members can include external experts and review boards can request support from external bodies (e.g., consulting services). Project management will provide sufficient resources, both financial and manpower, to support the reviewing process. The chair and members of the review board are to be selected to ensure maximum possible independence from both the reviewees and the project. Each review has a review authority who has the authority to act on the recommendations of the review. All review board reports also go to the Director of Programmes.

All staff are entitled and required to generate a red flag report if they become aware of a failure to meet the top-level requirements of the project or the specific requirements of the activity or work package in which they are involved. All red flag reports are copied verbatim to the Director of Programmes. Cost and schedule deviations can also generate red flag reports, but typically these will be reported through project control.

All components of the telescope, whether manufactured in industry or created at ESO, will undergo provisional acceptance before shipment to or acceptance by the observatory.

The project management relies upon the engineering manpower provided by the Directorates of Engineering, Science & Operations, and the Instrumentation Division. Planning for these resources is requested within the overall project plan and is updated on an annual basis as part of the ESO manpower allocation process. Project control ensures that the request is compatible with the overall schedule of the project.

8.7 COMMUNICATIONS

The project communications, including technical or scientific conference proceedings, follow the document release procedures discussed above. Press releases from ESO are managed through the ESO approval process, while communications by suppliers are governed by the contracts in place. The approval by ESO for contractor communications rests with the Director of Programmes.

8.8 STAFF EFFORT

All manpower working on the E-ELT programme is accounted for in E-ELT work packages. The activity managers are responsible for the correct allocation and tracking of the use of manpower and reporting to project control on deviations.

Technical support includes the provision of standardised solutions to the extent that they fit with the development plans and needs of the E-ELT project. The E-ELT project does not include the development

of standard solutions for components that lie outside its own direct needs. The sole exceptions to this rule are requirements arising from the integration of the E-ELT into the existing Paranal infrastructure.

Technical support will be contracted outside ESO for the following activities:

- Consulting engineering services for independent analysis, validation and supervision;
- As a minimum the dome and main structure contract will be supported by such services;
- Product assurance and quality control services at the manufacturers' premises
- Independent software validation and verification of ESO supplied components, the integrated telescope control system and at the suppliers' premises for local control units.

8.9 SAFETY MANAGEMENT

Safety management follows ESO's standard policy and the specific implementation for projects, "The ESO safety assessment procedure", is applicable to all contracts. Product safety is managed through the RAMS process that is included in quality and product assurance. The ESO safety assessment procedure specifies the methodology for the assessment of hazards.

Site safety is managed by the local site safety officer (in the case of Armazones, the Paranal safety engineer) supported by safety engineers operating on behalf of the contractor that is responsible for its own safety infrastructure, and additional construction safety engineers operating on behalf of ESO.

8.10 ESCALATION

Off-site safety and quality control issues are automatically reported to the Director of Programmes who will advise the Head of Administration and Director General as necessary.

Similarly, site safety and quality control issues are automatically reported to the Director of the Operations and the Director of Programmes who will advise the Head of Administration and Director General as necessary.

No escalation procedure is foreseen for these issues.

As a matter of principle, all staff are allowed and encouraged to escalate their concerns to the highest level they consider necessary. The Director General is the ultimate authority in such escalation and her/his decision is final and without appeal. The project will not place obstacles to the escalation process.

8.11 PROJECT CONTROL

The E-ELT will be controlled, as was the VLT and is currently ALMA, with a fixed Cost to Completion. The annual budget will be managed within the ESO Enterprise Resource Planning (ERP) system and will be inflated according to the annual indexation of the ESO budget (this will not increase the total funds allocated to the project as the baseline costs are established in 2012 euros).

The reporting of the project will include actual and forecast expenditures as well as percentages of work completed and earned value. In addition to informing and advising the project management, project control will generate the projections for each year's annual budget input process based on the predicted progress.

The budget and schedule system shall be compatible in order to produce EVM (Earned Value Management). Earned value metrics will be produced monthly in conjunction with monthly schedule updates. While the contingency will be held outside the project (see below) the calculation of the cost and schedule to completion will include projections of usage of contingency. The metrics will be generated both with and without contingency.

The schedule will be updated and published monthly and will have sufficient detail to give enough information to describe the major activities, especially those with interactions between work packages and activity areas. As a minimum, the integrated schedule shall track the fourth level of the work breakdown structure (i.e. typically at one level below that of the contracts) and to the lowest public interface level. Particular attention will be paid to key activities on or close to the critical path. The schedule will have a baseline schedule to measure deviations against. Significant changes to the baseline schedule shall be managed by the same change request process as for budget changes.

Schedule and cost deviations, irrespective of their cause, shall be included into the project management control system. The re-allocation of funds from one activity to another, irrespective of the impact on the cost to completion and irrespective of its inclusion within a single work package or activity shall be incorporated into the project management control system and will utilise a formal Change Request Management (CRE) approval process. The project manager can approve changes that do not require the release of contingency.

8.11.1 CONTINGENCY

Contingency may be used to burn down risk, recover schedule and for missing scope. It may not be used to recover scope in cases where the scope was removed as a result of an approved change to specifications. The status of the contingency will be reported on a monthly basis and will be expressed both in euros and as a percentage of the projected remaining cost to complete.

Contingency is held at the Directorate of Programmes level. Authorisation for release of contingency follows the same formal CRE process defined above.

8.12 RISK MANAGEMENT

E-ELT programme management recognises that managing risk is an essential and critical component for increasing the success of the E-ELT programme. Identifying objectives and understanding the risks that need to be managed to achieve those objectives will enhance management's ability to make better decisions, achieve programme delivery and operational performance targets, protect reputation and drive end user value.

Risk management builds on existing project management methods to provide a framework within which key risks can be identified, assessed, treated and reported in a visible, structured, consistent and continuous manner. This supports development and implementation of timely and cost-effective management action plans and underpins sound planning and performance management decision making.

The E-ELT risk management plan describes methods for the identification, assessment and reporting risks and for the development of appropriate response plans within defined risk tolerance levels. It also identifies the organisation for the management of risk including specific responsibilities and the documenting, monitoring, and reporting processes to be followed. As part of this process, risks are escalated to the appropriate level of authority.

All major suppliers are contractually obliged to keep an up-to-date risk register and report on risks to ESO on a regular basis.

8.13 CONFIGURATION AND CHANGE MANAGEMENT

Configuration control and change management are dedicated activities within the project and form part of the systems engineering process.

The configuration of the project is defined in the configuration item data list, containing all pertinent information that describes the configuration of the project at all levels and maps on to the work breakdown structure. The requirements are managed using the DOORS package and specifications are generated from within the DOORS package to ensure traceability. Configuration control for source code and executable code is managed as all other deliverables of the project.

Changes to the configuration are possible and a change request procedure is established which defines the Configuration Control Board (CCB), its membership and levels of authority. The CCB advises the project manager. Only the project manager can approve a change request or request for waiver. All changes are handled via the CRE process, but as not all changes may have the same level of impact, the procedure foresees a simplified path for minor CREs with a limited impact. For urgent CREs, a fast track process is offered.

8.14 INTERFACE MANAGEMENT

Interface management is a dedicated activity within the project and forms part of the systems engineering process. The interfaces are created between subsystems and based on specified templates. ESO retains ownership of all interfaces including those between two or more contractors and also in the exceptional case where a single contractor is providing the services on both sides of the interface. Public interfaces are ones between subsystems, are level 3 of the work breakdown structure and are used to define the project N² diagram. The interface does not contain specifications beyond the narrow bounds of its applicability.

8.15 QUALITY MANAGEMENT

The quality management assures that the E-ELT product assurance and quality control processes and procedures are applied both within the project and by the contractors. The quality management follows the E-ELT product and quality assurance procedures and is applicable to all contracts. The project, through the activity and work package managers, regularly updates the Director of Programmes on quality and RAMS issues. The quality management imposes a RAMS analysis of all activities, whether at ESO or at the contractors. All contractors are therefore required to develop and operate accordingly. The quality management process is supported by contracted specialist firms as well as dedicated in-house personnel. The control of deliverable documentation, training, spares, handling equipment and special tools and test equipment will be coordinated through the integrated logistic support manager. He/she will be responsible for monitoring individual contracts to ensure that the requirements of the final user are met within the deliverables.

8.16 ACCEPTANCE AND COMMISSIONING

The project accepts, on behalf of ESO, subsystems delivered by the contractors for integration into the E-ELT. The acceptance procedure follows the verification matrix created during the execution of the work by the contractor or by ESO and ensures that the complete acceptance data package meets the quality standards required by the contract and that the contractual and commercial obligations have been concluded appropriately. The technical acceptance process is led by the systems engineering team. Contractual matters are always handled exclusively by the ESO administration.

For subsystems developed by academic institutes, or internally at ESO, the same processes and procedures apply.

A similar process will accept the E-ELT observatory at the end of the project in order to demonstrate compliance with the top level science requirements. Systems engineering will also lead this process. The final acceptance of the E-ELT observatory into Operations will be a recommendation made jointly to the Director General by the Directors of Science, Operations, Programmes and Engineering.

9 SCHEDULE AND BUDGET

9.1 SCHEDULE

The five most critical paths to the handover of the telescope (with two instruments commissioned) to operations are firstly the *availability for commissioning of Instruments #1 and #2*. This is followed by *delivery of the M4 unit, delivery of the polished M1 unit glass for coating, and availability of the main structure* for integration of the mirror units and finally the *availability of the M2 unit* for pre-alignment on the main structure. The first four critical paths are each within one month of each other and can be effectively considered concurrent; over a 12-year period one month is within a margin of uncertainty. The fifth critical path (M2 unit) is three months earlier than the first four.

Examination of the percentage of risk and uncertainty of the critical path items places them in the order: *M2 unit (25%), M4 unit (19%), M1 unit (11%) and main structure (only 5%)*. The higher uncertainty value of the M2 and M4 units mean these tasks need to be particularly closely monitored. The M1 unit polishing phase has a ~ 12-month schedule margin included to buffer the effect of delays incurred while the main structure is seen to be low(er) risk. The instrument programme has for reasons related to its funding model not been assigned an uncertainty value.

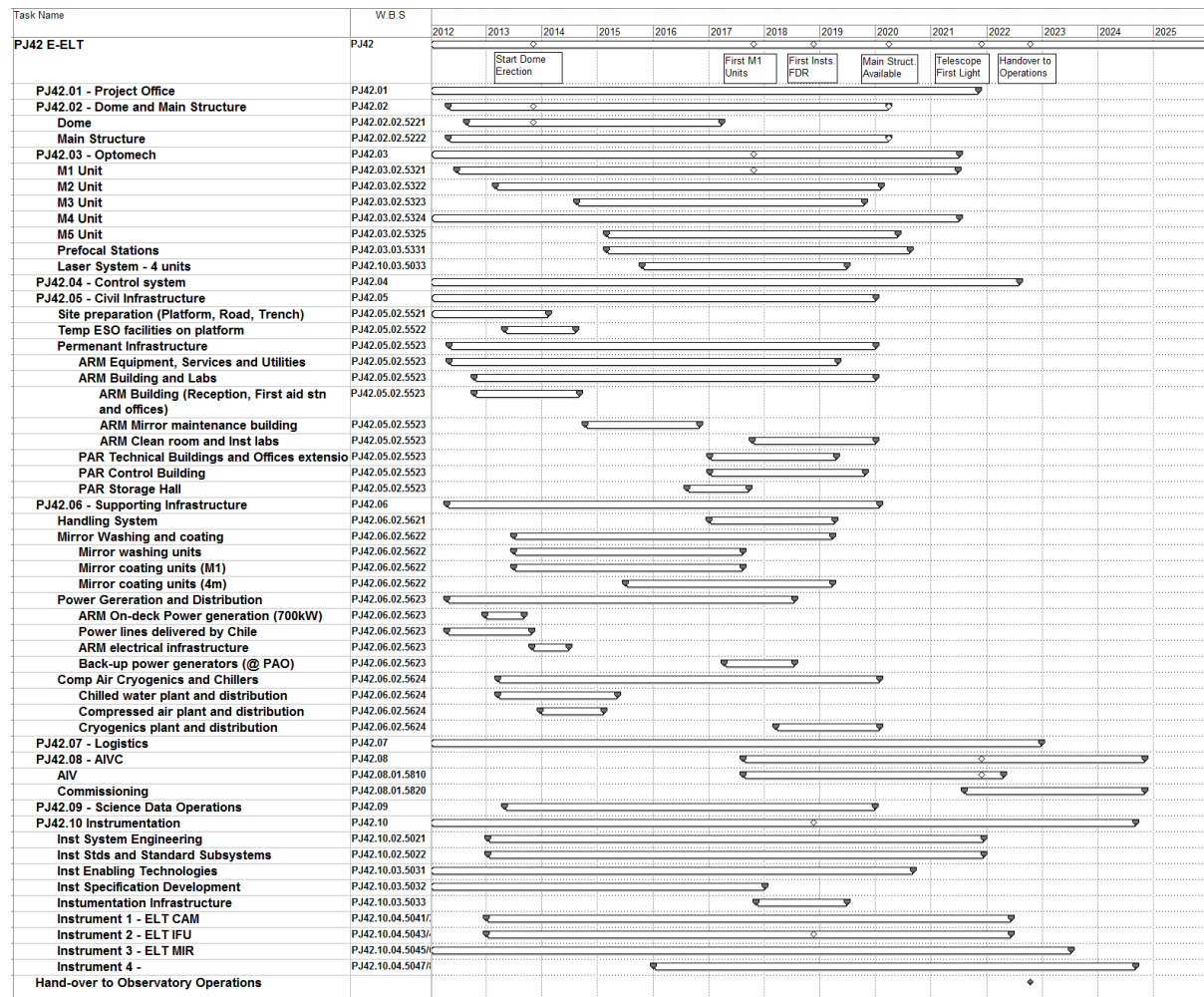

Figure 9.1. Project schedule.

Other important, but less critical, parts of the programme, see Figure 9.1, have been scheduled with consideration given to resource constraints of both man power and funding by planning their completion to be when strictly necessary to support successive tasks. For example the washing and coating plants, laser systems and pre-focal stations are all started as late as possible while leaving a reasonable margin

to the successor activities. The civil infrastructure and remainder of the supporting systems programme essentially fall into two phases. Those at the Armazones (ARM) site coming first since these are needed to support the early construction effort. Followed by the facilities needed both at ARM and Paranal (PAR) for integration, commissioning and eventually operations.

The administrative load on the Contracts and Procurement Department as well as the Finance Committee has also been taken into account so as not to overwhelm the process. It is foreseen that there will be E-ELT-related procurements brought to the FC each year from 2012 to 2019. Of the major procurements (> 500 k€) the majority will obviously be in the early stages, nonetheless there is a heavy workload for several years. In 2012 there will be four contracts (M4 unit, software development and verification, platform and road construction), 2013 nine, 2014 four, 2015 nine, 2016 six, 2017 and 2018 three each and finally one (software development) in 2019.

The instrumentation programme starts as soon as possible, and initially runs somewhat independently of the telescope, with three out of the four instruments progressing in parallel from 2013; the fourth will start in 2016. This reflects the development nature of the Instrument programme where there are techniques and technologies to be brought to maturity before committing to “cutting metal”. The first instruments physically meet the telescope for installation towards the very end of telescope system testing. Commissioning of the telescope (without instruments) then takes place while the instrument is integrated and readied for E-ELT commissioning in of the telescope and first light instruments. Overall, the process concludes with the integration and commissioning of the third and fourth instruments, but handover to operations will occur at the completion of commissioning of the first two instruments; at this point the E-ELT construction phase is complete.

9.2 BUDGET

Table 9.1 gives a summary breakdown of the project budget.

Contingency of 100 M€ has been applied to the project and is discussed in Section 1.7. As many of the budgets are based on the results of FEED studies (described in Section 1.4) the percentage that contingency is of the estimated budget is explained in Section 1.5.

The budget follows the WBS (Section 8.5) but is shown here condensed into few groups to give a more concise overview. The budget is presented inclusive of staff costs.

	M EUR
Telescope	
Dome and Main Structure	349
Optomechanical Systems	366
Control System	47
Infrastructure	
Civil and Supporting Infrastructure	58
Management, Logistics and Integration	
Project Office	38
AIVC, Site logistics and Data Operatio	25
Instrumentation	100
Sub-Total	983
E-ELT Project Contingency	100
Total	1,083

Table 9.1. Summary breakdown of the project budget.

Table 9.2 gives an overview of the schedule foreseen cash flow during the execution of the project. This forecast is the basis for the Performance Measurement Baseline (PMB) against which all financial and schedule performance are measured and changes will be managed.

	Telescope	Infrastructure	Management, Logistics and Integration	Instrumentation	Total
2012	4	4	3	1	12
2013	24	10	4	5	43
2014	68	9	5	7	88
2015	115	6	5	6	131
2016	126	4	6	6	141
2017	104	5	7	14	129
2018	69	8	7	9	92
2019	79	5	8	12	103
2020	92	5	9	17	123
2021	31	2	7	10	50
2022	47	1	3	8	60
2023	4	0	0	1	5
2024	-	-	-	5	5
2025	-	-	-	0	0
	762	58	63	100	983

Table 9.2. Overview of the schedule.

9.3 OPERATIONAL COSTS

The estimated operational costs based on the assumptions given within Chapter 5 assuming that the activities are coordinated within the Paranal operations are shown in Table 9.3.

Operations cost incl upgrade paths	Site	GAR	Total Budget	2019	2020	2021	2022	2023	2024	2025
Other cost	k€	k€	k€	k€	k€	k€	k€	k€	k€	k€
Investments	1,830	11,695	13,525	1,100	3,400	3,900	6,860	9,425	9,925	13,525
External services	3,700	750	4,450	20	50	100	2,375	4,650	4,850	4,850
Travel	1,230	320	1,550	70	115	470	1,190	1,500	1,550	1,550
Materials	6,210	370	6,580	0	10	25	2,845	5,680	5,780	5,880
Other operations	1,150	0	1,150	0	0	0	575	1,150	1,150	1,150
Other cost Total	14,120	13,135	27,255	1,190	3,575	4,495	13,845	22,405	23,255	26,955
Staff cost	10,735	2,933	13,668	830	1,253	2,163	12,590	13,668	13,668	13,668
Operations cost incl upgrade paths Total	24,855	16,068	40,923	2,020	4,828	6,658	26,435	36,073	36,923	40,623

Table 9.3. Operational costs for E-ELT.

10 ACKNOWLEDGEMENTS

Many individuals from the following industrial companies, agencies and scientific institutes have made important contributions to the work reported in this proposal and we should like to thank all of them most sincerely.

Industrial companies:

Active Space (Portugal), Active Space Technologies (Portugal), ADS (Italy), AMOS (Belgium), ARCADIS (Chile), ARUP (UK), ASDEA (Italy), Boostec (France), Brashaer (USA), Bronto Skylift (Finland), CESA (Spain), CILAS (France), CIRA (Italy), Cisco Systems (Germany), Corning (USA), Cosylab (Slovenia), Critical Software (Portugal), CSEM (Switzerland), Demont (Italy), DSL (Canada), e2v technologies (UK), EAI (Spain), EIE/Cimbolai (Italy), Fogale (France), Force Technology (Denmark), Franklin & Andrews (UK), Gerb (Germany), Heinmade (Netherlands), LZOS (Russia), ICAFAL (Chile), IDOM (Spain), INES (Switzerland), ISQ (Portugal), ITT (USA), Kirkholm (Denmark), KN Systèmes (France), LAM (France), MicroEpsilon (Germany) , Microgate/ADS (Italy) , Micromega (Belgium), Mott MacDonald (UK), MTM (Germany), Nallatech (UK), National Instruments (USA), NTE (Spain), Observatory Sciences (UK), ONERA (France), Optic-Glyndwr (UK), ORC (Finland), Physik Instrumente (Germany), Risiko (Chile), Rovsing (Denmark), Sagem (France) , Sanrof (USA), Schott (Germany), SciSys UK (UK), Scott-Wilson (UK), Solving (Finland), Space Systems Finland (Finland), Thales (SESO) (France), Threon (Germany), TNO TDP (Netherlands), Tomelleri (Italy), Toptica (Germany), UKATC (UK), Weatherpark (Austria), VDL (Netherlands).

Institutes and agencies:

ASTRON, CEA Saclay, CRAL, CSIC-DAMIR, ETHZ, European Union, FIZEAU, GEPI, IAC, INAF-IASF-Milano, INAF-Brera, INAF-OAA, INAF-OABo, INAF-OAPd, INAF-Trieste, InES-ZHAW, IoA, IPAG, KU-Leuven, LAOG, Leiden Observatory, LESIA, MPE, MPIA, NBI Copenhagen, NOVA ASTRON, NOVA Leiden, OAP, Obs. Genève, Obs. Haute Provence, OPTICON (EU), PUC, RUN, STFC RAL, TLS Tautenburg, UK ATC, Univ. Utrecht, Univ. Liege, Univ. Amsterdam, Univ. Bologna, Univ. Durham, Univ. Groningen, Univ. Oxford, Uppsala Observatory, USM, Univ. of Arizona.

11 LIST OF ACRONYMS

ADC	Atmospheric Dispersion Corrector
AHU	Air Handling Unit
AIT	Assembly and Integration Team
AIV	Assembly, Integration and Verification
AIVC	Assembly, Integration, Verification and Commissioning
ALMA	Atacama Large Millimeter/submillimeter Array
AO	Adaptive Optics
AOCU	Adaptive Optics Calibration Unit
Aquarius	Mid-infrared detector array
ATC	UK Astronomy Technology Centre
ATLAS	LTAO module
AU	Astronomical Unit
BepiColombo	ESA mission to Mercury
BigBOSS	Ground-based dark energy experiment to study baryon acoustic oscillations
CAN	Controller Area Network
CARP	Proprietary polishing process
CCB	Configuration Control Board
CCD	Charge Coupled Device
CEA	Commissariat à l'énergie atomique et aux énergies alternatives
CERN	European Organization for Nuclear Research
CFD	Computational Fluid Dynamics
CFRP	Carbon-Fibre-Reinforced Polymer
CGH	Computer-Generated Hologram
Chandra	NASA X-ray Observatory satellite
CIDL	Configuration Item Data Lists
CMM	3D-coordinate measuring machine
CMMS	Computerised Maintenance Management System
CNC	Computerised Numerical Control
CODEX	High resolution visual spectrograph
CoRoT	COncvection ROTation and planetary Transits
CP	Collapse Prevention limit state
CRAL	Centre de Recherche Astrophysique de Lyon
CRE	Change Request Management
CSIC	Consejo Superior de Investigaciones Científicas
CTE	Coefficient of Thermal Expansion
CTIO	Cerro Tololo Inter-American Observatory
DC	Damage Control limit state
DDS	Data Distribution Service for real-time systems
DES	Dark Energy Survey
DLR	Damage Limitation Requirement
DM	Deformable Mirror
DMO	Data Management and Operations Division
DOORS	Requirement management software
DRM	Design Reference Mission

DRSP	Design Reference Science Plan
EAAE	European Association for Astronomy Education
EAGLE	AO-assisted Multi-integral Field NIR Spectrometer
EE	Ensquared Energy
E-ELT	European Extremely Large Telescope
ELT	Extremely Large Telescope
ELT-CAM	E-ELT near-infrared camera
ELT-HIRES	E-ELT high resolution near-infrared instrument
ELT-IFU	E-ELT integral field spectrograph
ELT-MIR	E-ELT mid-infrared instrument
ELT-MOS	E-ELT multi-object spectrograph
ELT-PCS	E-ELT planetary camera and spectrograph
EPICS	Planet Imager, Spectrograph and Imaging Polarimeter with Extreme Adaptive Optics
ePOD	education and Public Outreach Department
EPOL	Exoplanet polarimeter for EPICS
eROSITA	extended ROentgen Survey with an Imaging Telescope Array
ERP	Enterprise Resource Planning (Administrative information system)
ESE	ELT Science and Engineering subcommittee
ESO	European Southern Observatory
ESON	ESO Science Outreach Network
ESPRESSO	Echelle SPectrograph for Radial vElocity Super Stable Observations
ESRC	ELT Standing Review Committee
ETD	Enabling Technology Development
ETHZ	Eidgenössische Technische Hochschule Zürich
EUCLID	ESA dark energy mission
Euro-50	Proposed extremely large optical and infrared telescope
EVALSO	Enabling Virtual Access to Latin-America Southern Observatories
EVM	Earned Value Management
FC	Finance Committee
FDR	Final Design Review
FEA	Finite Element Analysis
FEED	Front-End Engineering Design
FIZEAU	European Interferometry Initiative
FoV	Field of View
FPGA	Field-Programmable Gate Array
FTE	Full-Time Equivalent
FWHM	Full Width at Half Maximum
Gaia	Astrometric satellite (ESA)
GEPI	Galaxie – Etoile – Physique – Instrumentation, Observatoire de Paris
GIANO	Ultra-stable IR spectrometer for the Telescopio Nazionale Galileo
GIF	Gravity Invariant Focus
GLAO	Ground Layer Adaptive Optics
GMM	Geometrical Measuring Machine
GMT	Giant Magellan Telescope
GTC	Gran Telescopio Canarias
GTO	Guaranteed Time Observing

HARMONI	Single Field Integral-field Spectrograph
HARPS	High Accuracy Radial velocity Planetary Searcher (3.6-metre)
HATNet	Hungarian Automated Telescope Network
Herschel	Far-infrared and submillimetre space telescope
HETDEX	Hobby-Eberly Telescope Dark Energy Experiment
HiPER	High Power laser Energy Research facility
HST	Hubble Space Telescope
HV	High Voltage
HVAC	Heating, Ventilation, Air Conditioning
I/O	Input/Output
IAC	Institute of Astronomy Cambridge
IAU	International Astronomical Union
IFS	Integral Field Spectrograph
IFU	Integral Field Unit
IMF	Initial Mass Function
INAF	Istituto Nazionale di Astrofisica
ISO	International Organization for Standardization
ISVW	Independent Software Verification and Validation
IT	Information Technology
JPL	Jet Propulsion Laboratory
JWST	James Webb Space Telescope
k€	Thousand euros
Kepler	NASA exoplanet space observatory
KMOS	K-band Multi-Object Spectrograph (VLT)
LAM	Laboratoire d'Astrophysique de Marseille
LAOG	Laboratoire d'Astrophysique de l'Observatoire de Grenoble
LBT	Large Binocular Telescope
LESI	Laboratoire d'Électronique, Signaux, Images
LGS	Laser Guide Star
LHC	Large Hadron Collider
LISA	Laser Interferometer Space Antenna
LPO	La Silla Paranal Observatory
LPS	Laser Projection Subunits
LRU	Line Replaceable Units
LSST	Large Synoptic Survey Telescope
LTAO	Laser Tomography Adaptive Optics
LTSI	Linear Time and Space Invariant
LV	Low Voltage
M€	Million euros
MAORY	Multi Conjugate Adaptive Optics module
mas	Milliarcseconds
MCAO	Multi-Conjugate Adaptive Optics
MEarth	Transit survey of ~ 2000 nearby M-dwarfs (super-Earths)
METIS	Mid-infrared Imager and Spectrograph with AO
MICADO	Imager and Slit Spectrograph
MIR	Mid-infrared

MIRI	Mid-Infrared Instrument (JWST)
MLE	Maximum Likely Earthquake
MMT	Multiple Mirror Telescope
Mn	Mirror #n
MOAO	Multi-Object Adaptive Optics
MOND	Modified Newtonian Dynamics
MOS	Multi-Object Spectroscopy
MOSFIRE	Keck NIR multi-object spectrograph
MoU	Memorandum of Understanding
MPE	Max-Planck Institute of Extraterrestrial Physics
MPIA	Max-Planck Institute of Astronomy
MRI	Magnetic Resonance Imaging
MTBF	Mean Time Between Failures
MUSE	Multi Unit Spectroscopic Explorer
MV	Medium Voltage
NASA	National Aeronautics and Space Administration
NBI	Niels Bohr Institute
NCR	No-Collapse Requirement
NGS	Natural Guide Star
NIR	Near-infrared
NOVA	Netherlands Research School for Astronomy
NSF	National Science Foundation
ONERA	French Aerospace Lab
OPTICON	Optical Infrared Coordination Network for Astronomy
OPTIMOS- DIORAMAS	Imager and slit mask-based multi-object spectrometer
OPTIMOS-EVE	Optical-NIR Fibre-based MOS
OWL	Overwhelmingly Large Telescope
PA	Product Assurance
PACT	Position Actuators
Pan-STARRS	Panoramic Survey Telescope and Rapid Response System
pc	Parsec
PCB	Printed Circuit Board
PDM	Product Data Management tool
PDR	Preliminary Design Review
PDR	Preliminary Design Review
PGA	Peak Ground Acceleration
PI	Principal Investigator
Planck	ESA's microwave observatory
PLATO	PLANetary Transits and Oscillations of stars
PLC	Programmable Logic Controller
PMB	Performance Measurement Baseline
ppb	parts per billion
PRS	Problem Reporting System
PSD	Power Spectral Density
PSF	Point Spread Function

PUC	Pontificia Universidad Católica de Chile
R&D	Research and Development
RAL	Rutherford Appleton Laboratory
RAMS	Reliability, Availability, Maintainability and Safety
RCM	Reliability Centered Maintenance
rms	Root mean square
RTC	Real-Time Computer
SA	State Analysis
SAO	Sagem proprietary process
SCAO	Single Conjugate Adaptive Optics
SiC	Silicon Carbide
SIMPLE	Cross-dispersed Echelle Spectrograph, Long-slit Option
SINFONI	Spectrograph for INtegral Field Observations in the Near Infrared (VLT)
SKA	Square Kilometre Array
SL	Serviceability Limit state
SMP	Stressed Mirror Polishing
SOFIA	Stratospheric Observatory for Infrared Astronomy
SPHERE	Spectro-Polarimetric High-contrast Exoplanet Research instrument
Spitzer	NASA Spitzer Space Telescope
SR	Strehl Ratio
SSAC	Site Selection Advisory Committee
STC	ESO Scientific and Technical Committee
SWG	Science Working Group
TBC	To Be Confirmed
TBD	To Be Done
TLS	Thueringer Landessternwarte Tautenburg
TMT	Thirty Meter Telescope
ToO	Target of Opportunity
TRL	Technology Readiness Level
ULE	Ultra-Low Expansion glass (Corning)
UPS	Uninterruptible Power Supply
USM	University Observatory Munich
UT	Unit Telescope
UU	Utrecht University
UVES	UV-Visual Echelle Spectrograph (VLT)
VECSELS	Vertical External Cavity Surface-Emitting Lasers
VISIR	VLT Mid-Infrared Imager Spectrometer
VISTA	Visible and Infrared Survey Telescope for Astronomy
VLT	Very Large Telescope
VLTI	Very Large Telescope Interferometer
VME	Virtual Machine Environment
VPH	Volume Phased Holographic
VST	VLT Survey Telescope
WBS	Work Breakdown Structure
WEB	Wind Evaluation Breadboard
WFE	Wave Front Error

WFIRST	Wide-Field Infrared Survey Telescope
WFS	Wave Front Sensors
WISE	Wide Field Infrared Survey Explorer
WMAP	Wilkinson Microwave Anisotropy Probe
XAO	Extreme Adaptive Optics
XMM-Newton	X-ray Multi-Mirror satellite (ESA)
Zn	Zernike coefficient of order n
μas	microarcseconds