

Gon Bops™

2021



Contents



4
NEW FOR 2021



8
CAJONS



18
CONGAS and BONGOS



32
DJEMBES



38
TIMBALES



46
BELLS



52
TAMBOURINES



58
SHAKERS



71
BLOCKS



72
CLAVES



74
BRAZILIAN PERCUSSION



77
SOUND EFFECTS

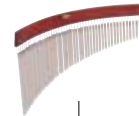

82
CHIMES



86
TRIANGLES



87
STANDS &
HARDWARE



94
ACCESSORIES



100
BAGS

Lenny Castro Custom Series



Our new Lenny Castro Signature Series Congas and bongos feature Asian Oak shells and come with teardrop top rings, for ease of extended playing time. Each head is hand-selected from natural rawhide, providing a warm, rich tone and features Lenny's hand-drawn skull logo. Gon Bops Lenny Castro Series drums boast eye-popping, exciting original artwork, highlighting Lenny's identifiable sunglasses, skull and conga sketches. A true reflection of this master percussionist, at an approachable price range.

Asian Oak Shells | Natural Rawhide Heads | Teardrop Comfort Top Rings

TP1075LC | Quinto
TP1150LC | Conga
TP1225LC | Tumba
TP1325LC | Super Tumba
TP0785LC | Bongo

7"/8.5" Bongo available



Alex Acuña Triple Shaker PSHAA3

Gon Bops' new Alex Acuña Signature Triple Shaker is highly versatile, providing the player with various, exciting playing options. 12" in length, our Acuña Triple Shaker features 3 separate tubes, fastened together by heavy duty, rubber clips. Easily separated, giving the option of playing a single, double or triple shake combination, to accommodate any desired volume level and timbre. Constructed from lightweight, sturdy plastic in a stunning high-gloss finish, the Alex Acuña Triple Shaker joins our state-of-the-art Alex Acuña Signature instrument series!



3 separate, plastic shaker tubes | Single, double or triple shaker application | Warm, rich tones

Alex Acuña Special Edition Cajon AACJSE



Gon Bops #1 best-selling instrument. Designed with Alex Acuña, 100% handcrafted in Peru for sublime tone and performance. Built to provide deep bass tones and accurate snare and slap sounds with unsurpassed separation.

Mohena | 13.5" x 18.5" x 11.5" | FREE Bag

Alex Acuña Signature Cajon AACJ



Our traditional Peruvian box cajon (no snare wires) is 100% handcrafted in Peru. Designed with Alex Acuña, it provides loud, tight bass response for classic traditional cajon sound.

Mohena | 13.75" x 19" x 11.5" | FREE Bag

Mixto Cajon CJMX



We blend the flamenco tradition of Spain with the Peruvian folk tradition by using two playable panels and a side sound port design. 100% handcrafted in Peru.

Mohena | 13.5" x 18.5" x 11.5" | FREE Bag

Flamenco Cajon CJFL



Lightweight wood construction and internal guitar string wires deliver authentic Spanish Flamenco tone. 100% handcrafted in Peru.

Capinuri | 13.5" x 18.5" x 12" | FREE Bag

Daniel de los Reyes Signature Cajon CJDR

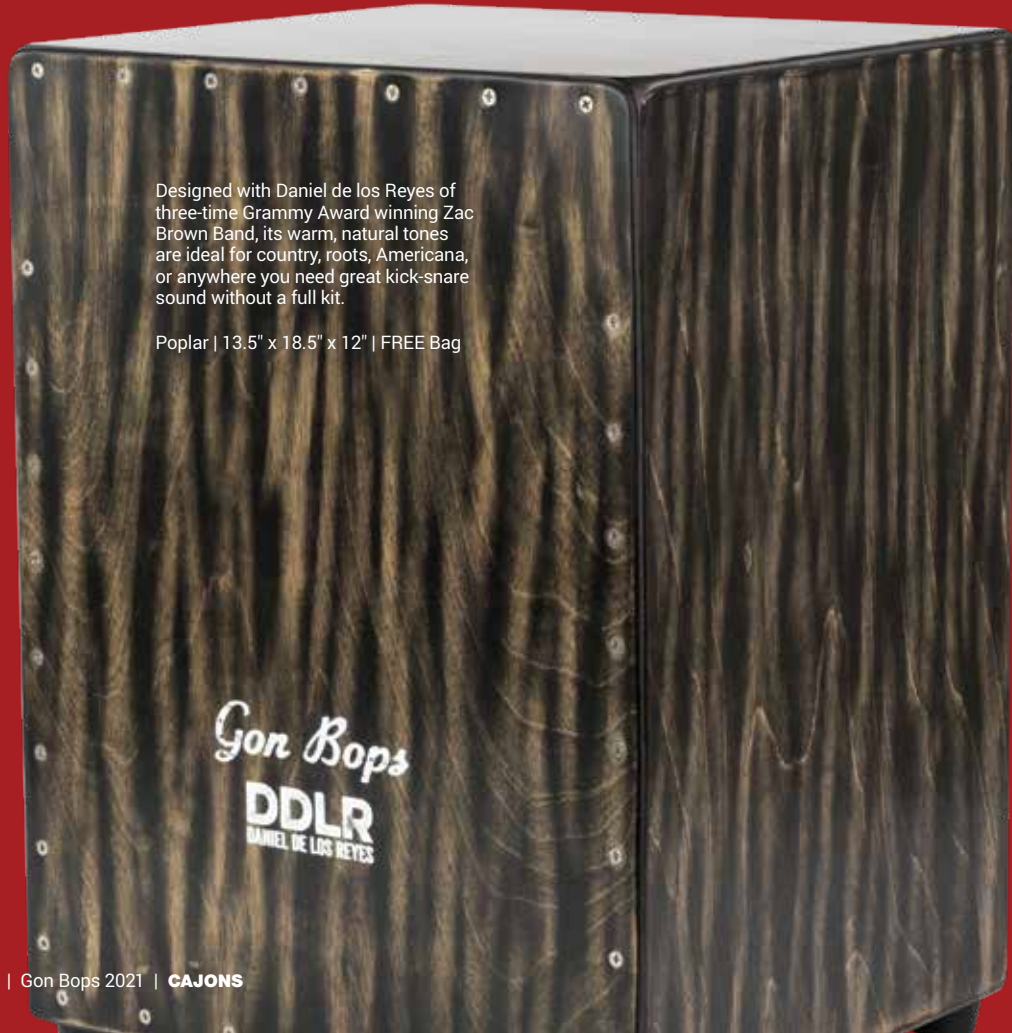

Designed with Daniel de los Reyes of three-time Grammy Award winning Zac Brown Band, its warm, natural tones are ideal for country, roots, Americana, or anywhere you need great kick-snare sound without a full kit.

Poplar | 13.5" x 18.5" x 12" | FREE Bag

Tumbao Pro Cajons



TPCJBTB

Available in two handsome finishes – Walnut and Burnt Toast Burst – our Maple front panel and internal snare wire design delivers plenty of high-end "pop" without sacrificing low-end.

TPCJW

Maple | 12" x 18" x 12" | FREE Bag

Fiesta Cajons

Available in 4 fresh, new colours, these cajons offer sound and quality well above their price point. All 4 new models feature internal, adjustable snares, large rubber feet for superior isolation and a size and form factor that is beginner friendly. Just pick your favorite colour and you're ready to play!

Wood/MDF | 12" x 18" x 12" |
Adjustable snare



FSCJUV | Ultra Violet
FSCJLC | Lime Crush
FSCJCB | Cherry Bomb
FSCJWM | White Magic



FSCJW | Walnut



FSCJM | Mahogany

Offered in a choice of mahogany or walnut finish, Fiesta cajons are ideal for students and beginners. Or pick one up as your grab'n'go cajon. The Walnut model offers a side-panel snare adjustment, while the Mahogany includes internal, adjustable jingles and guitar string wires.

Birch | 11.375" x 19" x 12" | FREE Bag

Commuter Cajon CJCOM



Fully collapsible, the Commuter fits neatly into a backpack for easy transport to gigs, rehearsals and sessions, making it an ideal choice for urban commuters. Did we mention, it also delivers killer Flamenco tones with loud, tight bass?

Maple & Laminate | 11.75" x 19.75" x 11.5" | FREE Backpack

Bongo Cajon CJBONGO



Unique Gon Bops design features covered-bottom and 2 sound ports. 100% handcrafted in Peru, this is hands-down the best sounding bongo cajon on the market.



Mohena | 15.5" x 9.75" x 7.75" | FREE Bag

California Series



Uncompromising in quality and sound, each drum is 100% hand-crafted in North America from Appalachian Red Oak. Solid stave construction and contour top ring are hallmarks of GB design, as are traditional side and backing plates. Available in Natural and Mahogany finishes. The ultimate Congas!

Red Oak | Remo Nuskyn Head | Contour Top Ring

CA0975N | Super Quinto
CA1075N | Quinto
CA1150N | Conga
CA1225N | Tumba
CA1325N | Super Tumba
CA0785N | Bongo
Replace N with MS for Mahogany finish.

7"/8.5" Bongo available



Alex Acuña Special Edition Series



Designed for the legendary Alex Acuña from North American Ash and finished in stunning ebony lacquer. These gorgeous drums feature Ash wood stave construction, contour comfort top ring, and Remo Skyndeeep heads for superb performance and bright, cutting tone that projects.

Ash | Remo Skyndeeep Head | Contour Top Ring

AA0975SE | Super Quinto
AA1075SE | Quinto
AA1150SE | Conga
AA1225SE | Tumba
AA0785SE | Bongo

7"/8.5" Bongo available



Roberto Quintero Signature Series



Designed with Master Conguero Roberto Quintero, these beautiful drums produce deep, resonant bass tones and loud, cutting highs, as only fiberglass drums can deliver. Fitted with custom Remo Skyndee heads, and Gon Bops California Contour top ring and hardware, these are professional level instruments. But drummers at all levels will appreciate their outstanding sound, unmatched quality and light weight.

Fiberglass | Remo Skyndee Head | Contour Top Ring

RQ1150R | Conga
RQ1225R | Tumba
RQ1325R | Super Tumba
RQ0785R | Bongo



Alex Acuña Signature Series



Traditional teardrop top ring offers long-playing comfort, and North American Ash stave construction paired with natural hide heads delivers warm, natural tone.

Ash | Natural Hide Head | Teardrop Top Ring

AA0975N | Super Quinto
AA1075N | Quinto
AA1150N | Conga
AA1225N | Tumba
AA0785N | Bongo

7"/8.5" Bongo available



Mariano Series



Named after GB founder Mariano Bobadilla, these wonderful drums continue our tradition of authentic Cuban look and feel. Designed with genuine calfskin heads, select lightweight Durian wood and traditional hardware, their big, resonant open tones and crisp slaps are the sound of Cuba! Now available in a chrome hardware option.

Durian | Cowskin Head | Vintage Top Ring

MB1075 | Quinto
MB1150 | Conga
MB1225 | Tumba
MB1325 | Super Tumba
MBBG | Bongo
Add CR to product number for chrome hardware.



7"/8.5" Bongo available



Tumbao Pro Series



Crafted from plantation grown Parawood, these professional grade drums are designed with teardrop top ring and hand-selected natural skin heads for warm, natural tone. Offered in Walnut finish, they deliver nothing less than legendary Gon Bops quality and sound at a smart price.

Parawood | Natural Hide Head | Teardrop Top Ring

TP1075WA | Quinto
TP1150WA | Conga
TP1225WA | Tumba
TP0785WA | Bongo

7"/8.5" Bongo available



Fiesta Series



Fiesta Congas deliver Gon Bops quality and tone at a price designed with the average player's budget in mind. The black powder-coated teardrop top ring provides long-playing comfort, while Mango shells and pre-fitted rawhide heads produce rich open tone and tight, crisp slaps. A durable, lightweight stand is included with this full-size 11"/12" conga/tumba set. Full size 7"/8.5" Bongo also available.

Mango | Natural Hide Head | Fiesta Hardware

FS1112SETN | Natural
FS1112SETSB | Sunburst
FS785N | Bongo – Natural
FS785SB | Bongo – Sunburst



Alex Acuña Special Edition 14" Djembe AADJ14SE



The combination of Asian Oak shell and Remo Skyndeeep head with Goatstripe black graphic produces massive tone and impressive volume, with deep, rich lows and beefy, cutting slaps. Gon Bops California hardware provides flawless tuning and set-up. And a stunning ebony lacquer premium-quality finish is a perfect match with Alex's Special Edition Congas and Bongo.

Asian Oak | Remo Skyndeeep Head | 14" x 28.5"

Mariano Djembe



MBDJ10 | 10"



Crafted from Durian wood for extreme lightness and strength, with a compact top ring that's designed to fit nice and tight to the player's body. An exceptionally high-tuning capability delivers strong bass and high, cutting slaps. The Remo Black Suede head is smooth to the touch and provides excellent warmth and articulation. Extremely light, the 12" Mariano Djembe is a killer sounding, portable instrument that's ready to go on the road!

Durian Shell | Remo Black Suede Head | 10" & 12"

MBDJ | 12"

Fiesta Djembe FSDJW



Solid, lightweight and comfortable to play, our introductory Djembe provides clear, full-bodied tone, with good depth. A synthetic head offers excellent performance and durability. A large, solid black rubber ring on the base provides stable, non-slip surface.

Walnut Finish | Synthetic Head | 11.5"



Fiesta Djembes

Offered in matching colors to our Fiesta Color Cajon line – White Magic, Lime Crush, Cherry Bomb and Ultra Violet – Fiesta Djembes are crafted from Mango wood staves. Fitted with Remo white suede head, they deliver an impressively wide range of tone that can be easily tuned for pitches from a doumbek to a djembe.

Mango wood | Remo White Suede Head | 10" x 19"



FSDJWM10



FSDJLC10



FSDJCB10



FSCJUV10

14" Banda Snare BNDSN14

Our premium Banda drum boasts a stainless steel shell, triple-flanged hoop, 24 steel lugs, 42-strand snare, ultra-smooth, ball-action throw-off and a durable two-ply head. It has been designed to exceed the rigorous demands of Banda musicians, for both quality and sound, but will have appeal to drummers in many other genres.

Stainless Steel Shell | Two-Ply Head | 14" x 8.5"



8" Timbale Snare TBSN8

Blending the exciting textures and accents of a traditional Latin timbale with a sensitive, long-range snare throw-off, our 8" Timbale snare provides players the ability to play cutting, barking timbale fills with a snare back-beat at their fingertips. The unique long-range throw-off allows drummers to slowly add snare sound, from loose rattle to snappy, cracking backbeat. Players will also appreciate the super-light weight offered by our premium aluminum shell.



Luisito Quintero Signature LQTB1415



Created with Master Timbalero Luisito Quintero, this chrome over steel timbale set provides highly versatile, penetrating tone for Latin, Jazz, Rock or Pop. The superb shells deliver lively cascara designed to cut with clarity, and low-profile hardware with recessed tuning rods offer unparalleled playability. The set is rounded out with heavy duty Gon Bops 3-Series stand with Push-Lock mounting system and Mega-Tripod base, designed to withstand the toughest touring schedule.

Chrome over steel | 3-Series stand | 14"/15"

Alex Acuña Signature AATB1415



Designed for Alex Acuña with a brass shell for dark cascara and bright, articulate tone. With quality features like recessed tuning rods, traditional steel counter hoops and innovative GB 3-Series stand with Mega-Tripod™ base, these amazing drums are built to withstand the rigors of professional touring.

Brass | 3-Series Stand | 14"/15"

Orestes Vilato Signature VTB1415



This simple, elegant design by legendary Timbalero Orestes Vilato incorporates shallow 4" shells with flat, level bearing edges – so drums are easily stacked for transport in a snare bag. Aluminum shells offer bright, clear attack, while the cascara is warm, but loud enough to cut.

Aluminum | GB Lightweight Stand | 14"/15"

Fiesta

Our new Fiesta timbales with lightweight, tilting chrome stand are smartly priced with the average percussionist's budget in mind. Their wide lug placement makes for easy cascara, and a bracket, cowbell and tuning wrench round out the package. Being on a budget is no reason to compromise on sound and quality!

Chrome over steel | Fiesta Stand



FSTB1415 | 14"/15" Set

Also available:
FSTB1314 | 13"/14" Set

Alex Acuña Signature Bells



Inspired by Alex's vast collection of favorites, AA Bells are lively and versatile with the perfect sound for Salsa, but enough traditional tone to work in any musical setting. Heavy gauge steel with welded overlap seams. All bells except Campana feature V-Grip mount.

Heavy-gauge Steel | V-Grip Mount

Timbero Bells



Designed for modern Latin sounds, Timbero Bells feature heavy gauge steel construction with welded overlap seams. Plenty of volume, and distinctive red paint job get you heard – and seen!

Heavy-gauge Steel | V-Grip Mount

Pete Engelhart Bells



PECB | Clave



PESEB | Shield



PEBS | Satellite



PE3TRI | 3 Bell Triangle



PETS | Timbale Set

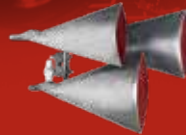

PEB3 | 3 Bell



Highly-regarded as the most innovative bells in the world, Pete's instruments are hand-welded from raw steel - no two bells are alike! Series includes 7 visionary designs, all bells feature Gon Bops patented V-Grip mount.

Heavy-gauge Steel | V-Grip Mount

Tumbao Bells



B084 | Timbale

B085 | Rock

B085H | Hand

B043 | Cha-Cha Alto

B032 | Chachita

B053 | Cha-Cha

Designed for virtually any musical setting, Tumbao Bells produce a drier sound with minimal overtones and less sustain.

Steel | V-Grip Mount



BAG011 | Agogo

BDB1 | Timbale Double Bell Set



Fiesta Bells



Crafted from clear-coated raw steel with excellent sound and performance at a smart price. Eye-bolt clamps accommodate up to 3/8" mounting rods.

Clear-coated Raw-steel | Eye-bolt clamp

Cowbell Beater SMCBBTR

Gets deeper, richer tone from your cowbells than using conventional drumsticks.



Foot Bell Stand PPDLSTD2

Designed for musicians who need a strong, light and portable stand for their cowbells, blocks, and more. Sturdy and portable, it folds easily into any gig bag. It attaches to any standard bass drum pedal, and the 3/8" adjustable post slides to the perfect position.



Lenny Castro Signature Tambourines

Renowned for his deft touch and rich tone on the tambourine, Lenny Castro was key to designing these professional-quality instruments. The single-row model features warm, articulate brass jingles, while the double row uses bright, cutting stainless steel jingles. The Asian oak shell is lightweight and strong, and a natural skin head provides outstanding performance.



PTAMLC1



Asian Oak Shell | Brass Jingles | Cowskin head

PTAMLC2

Asian Oak Shell | Stainless Steel Jingles | Cowskin head

Daniel de los Reyes Tambourine PTAMDDL



Designed for full, thick sound, using hammered jingles to provide warm tone that cuts. Strong and light, it offers excellent playability and durability for the most rigorous of tour schedules. The excellent weight distribution not only makes it fun and easy to play, it's also perfectly balanced to execute fast, quick rhythms. Its vintage wood look is designed to match Reyes' signature Gon Bops DDLR Cajon.

Wood Tambourines



Full-sounding tambourines solidly constructed from light 7-ply Basswood shells. Includes two 10" single-row and two 10" double row instruments - with and without heads. Extremely lightweight, they deliver the sonic timbre and range to cover any style of music.

PTAMW1 | Single Row Jingles
PTAMWH1 | Single Row Jingles with Head
PTAMW2 | Double Row Jingles
PTAMWH2 | Double Row Jingles with Head

Plastic Tambourines



The widest range of tone available, built for durability and musicality. Available in 4 distinct colour/ jingle combinations. Through-handle quick release design holds instrument firmly in place without sacrificing ergonomics. Includes V-Grip mount.

PTAM10 | Steel



PTAMAL | Aluminum



PTAMTR | Trashy



PTAMBR | Brass



Redesigned V-Grip Mount now fits snugly on all hi-hat rods!

Jingle Stick PJINGM



A rugged, great-sounding instrument that's built to last. Through-handle quick release with patented Gon Bops V-Grip mount holds instrument securely in place without sacrificing ergonomics.



Shekere PSHEK



Fiberglass shell design delivers bright, clear tone and resonant bass. Adorned with plastic beads, this durable, lightweight instrument is built to last!

Red Cabasa PCABRM

Designed for playability, versatility, and full, bright sound, our new Red Cabasa boasts lightweight wood construction, comfortable grooved handle and a vibrant Gon Bops' Red paint job that's sure to get you noticed on stage!



Daniel de los Reyes Shakers

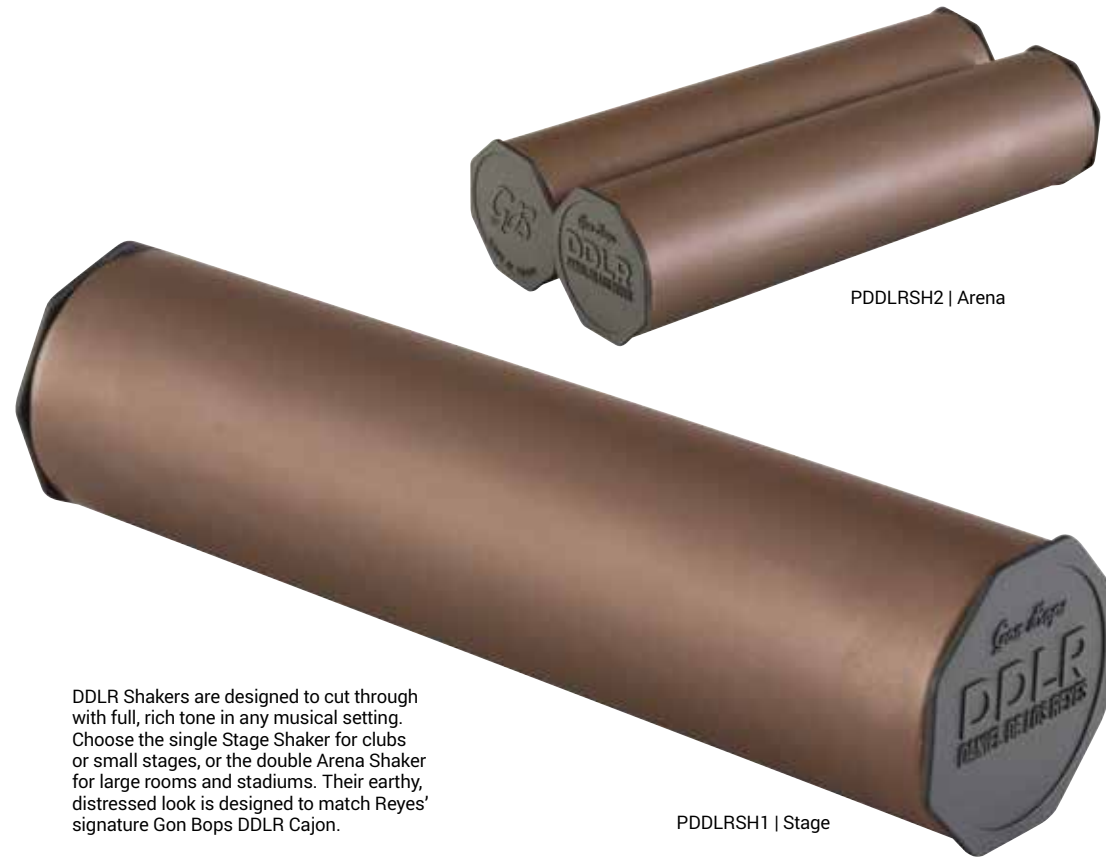

DDLRS Shakers are designed to cut through with full, rich tone in any musical setting. Choose the single Stage Shaker for clubs or small stages, or the double Arena Shaker for large rooms and stadiums. Their earthy, distressed look is designed to match Reyes' signature Gon Bops DDLR Cajon.

Talking Shakers

Crafted from wood and cowhide, each shaker is capable of producing a surprising variety of tones and pitches depending on how they are gripped and squeezed. Available in small (PSHS1PR) and large (PSHSPR) pairs. Only from Gon Bops!



Drum Shakers PDS3PK



You must play this set of 3 Shakers to appreciate how great they sound – and feel! Crafted from wood and cowhide, they deliver solid, chunky shaker tones with 3 distinct pitches. Only from Gon Bops.

Rock Shaker PSHRT



Easy-to-play shaker provides enough versatility for any musical setting. Ultralight metal design is built to last, with tone that cuts.

Metal Shaker PSHM



Play clave patterns on the flat side or cup your hand over recessed side to create unique shaker tones. Heavy-duty steel construction cuts well in live applications.

Mic Shakers



PSHM1 | Silver



PSHM2 | Black

Perfect for bright, percussive accents. Unique threaded mic head design allows you to separate for a pair of shakers, or play them together as one. Available in loud, bright silver model with plastic balls or warm sounding black model with aluminum balls.



Fiesta Mini-Cajon Shakers FSPSH4PK

A four-pack of mini-cajon shakers, offering four distinct shaker tones. Cherry Bomb, Lime Crush, Ultra Violet and White Magic colours make a great addition to your collection of shakers, and are a perfect gift for the young percussionist in your life.



Fiesta Wood Shakers FSPWSH3



A 3-pack of Wood Shakers designed to offer sharp, high-pitched sounds for percussionists at all levels. Smartly-priced, Fiesta Wood Shakers are easy to add to your percussive arsenal, no matter what your budget or musical style.

Plastic Maracas



Loads of dynamic percussive attack make these an ideal pair for playing straight time or fast patterns. Available in large or small pairs.

PMARPS

Rawhide Maracas

Rawhide construction produces dynamic midrange pitch and darker tones than our Plastic Maracas. Available in large or small pairs.



PMARRLL

PMARRS

Bell Block



PJAMBELL

A sturdy instrument that's designed to hit hard and play loud. Double swivel-point bracket with V-Grip mount provided unparalleled set-up flexibility. Available in red.

Claves

AFRICAN

Crafted from solid hardwood, they produce dark, rich melodic tone. The lowest-pitched clave set from GB.

PCLAVAF



ULTRALIGHT

Built from rugged, impact-resistant aluminum for very bright, loud tone.

PCLAVM



HICKORY

Crafted from select choice Hickory wood, these bright, high-pitched claves deliver the same cut and timbre as traditional Rosewood claves. Ideal for Latin, Afro-Cuban, or Jazz. Sold in a pair.

PCLAVH



Our best-selling claves. Rosewood has always been prized for its classic Afro-Cuban clave sound. Its controllable bright tone offers the widest dynamic range. Offers plenty of cut for Latin and modern musical sounds.

PCLAVRW



WHITE WOOD

Medium pitch and mellow attack is perfect for smaller ensembles. Ideal for Rumba.

PCLAVW



Caxixi



PSHCX1 | Mini

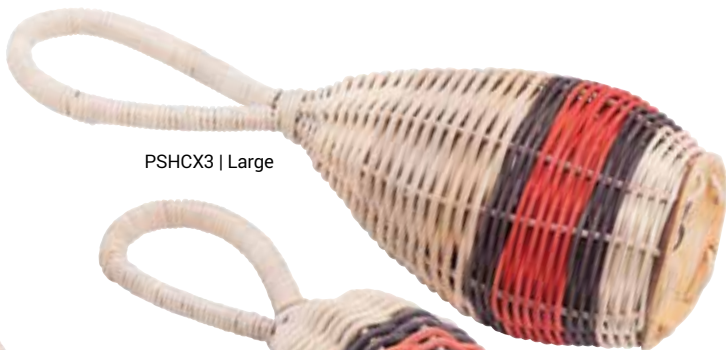

PSHCX3 | Large



PSHCX2 | Small



PSHCXB | Berimbau

With origins in ancient West Africa, it was believed Caxixi could summon good enchanted spirits and ward off evil spirits. Gon Bops Caxixi are 100% hand woven in Brazil from natural, sustainable materials. The combination of wild banana tree seeds striking the hard gourd skin base produces lively, organic sounds to provide excellent rhythmic accompaniment and color. They can be played as a single shaker to drive the beat, or used in pairs to produce intricate sounds and textures.

Bucket Shekere PSHEKBK

Based on the *Xequibalde*, a Brazilian folk instrument, this is the first of its kind to be manufactured outside of Brazil. Quite literally a hybrid of a metal bucket and a shekere, the Bucket Shekere can be played in hand like a traditional shekere, or placed on a stand – a snare stand works perfectly – and played with brushes or hands. Designed primarily to be super light, for long-playing comfort, it provides a rich, warm percussive attack.



Pandeiro

Our Pandeiros are extremely lightweight for long playing comfort. Their warm-sounding, precise platinelas provide exceptional articulation, and the custom Gon Bops head offers rich tone and excellent support for finger roll patterns. Available in 8" and 10" models, they include pro-carrying case with shoulder strap, and tuning key.



PPNDR8 | 8"

Basswood | GB Synthetic Head | 355 g



PPNDR | 10"

Basswood | GB Synthetic Head | 440 g



Hi-Hat Jingle Ring PJINGHH

A well-priced accessory for drummers, the Hi-Hat Jingle ring is a great way to get more sounds from your Hats. Lightweight and low profile, it won't affect pedal action. The 16 chrome-over-steel jingles offer excellent projection and cut. And the raw steel frame with beefy bent wing-screw gives it a vintage vibe that looks great on your kit.



Sleigh Bells PSB25



Gon Bops 25-jingle Sleigh Bells offer that traditional holiday sleigh bell jingle sound we all know and love. With its ergo wooden handle and shiny steel bells, this classic instrument is perfect for the holidays or other uses like traditional English Morris folk dancing, or symphonic applications.

Crasher Deluxe PCRDx



The perfect stacked metal sound, our Crasher Deluxe fits smartly within any setup. With two sets of blades (stainless steel & aluminum), you can choose between loud and cutting, or soft, white-noise effects. When mounting either set, you can tighten them down for short quick blasts, or not-so-tight for longer sustain. You can also mix and match blades to create your own unique sounds. Includes Gon Bops V-Grip mount, with 2-point tightening mechanism (wing-nut and drum key), for the strongest, most-secure hold possible.

Fiesta Guiro FSGUIR

Constructed from lightweight plastic with tight, precise playing grooves for accurate articulation. A long-body shell design is ideal for projection in any setting. Includes wood and plastic scraping sticks. Smartly priced to fit any percussionist's budget.



Flexatone/Rattleclap

FLEXATONE
For low or high pitched vibrato sounds, depending on pressure applied to steel spring. Or play it with a triangle beater for even more tones (not included).
FLEX



RATTLECLAP
For classic, rattling jawbone sounds!
Metal and wood construction for sustain and durability.
PRATH

Ergo Bar Chimes PCHERG47

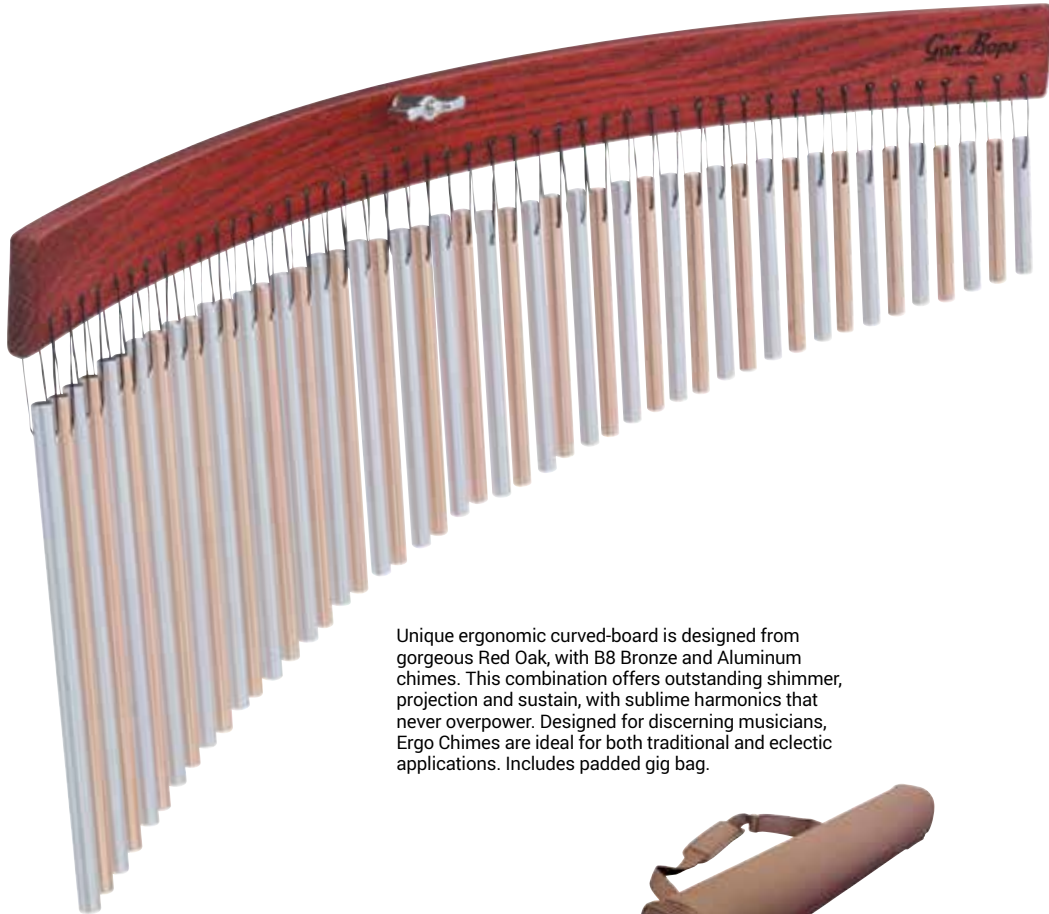

Unique ergonomic curved-board is designed from gorgeous Red Oak, with B8 Bronze and Aluminum chimes. This combination offers outstanding shimmer, projection and sustain, with sublime harmonics that never overpower. Designed for discerning musicians, Ergo Chimes are ideal for both traditional and eclectic applications. Includes padded gig bag.



Waterfall Shell Chimes PCHMSH



Handcrafted in Peru from the shells of Shacapa tree fruit, 26 strands create unique rustling and rushing water sounds. Includes mounting bracket, stand not included.

Bar Chimes



B8 BRONZE BAR CHIMES

Designed for discerning musicians, with 36 Sabian B8 Bronze chimes tied to a gorgeous Red Oak board with braided 50lb line. Ideal for full sound at moderate to high volume, with rich, complex shimmer and long sustain – the focus is in the mid-to-high range.
PCHB836

B8/ALUMINUM BAR CHIMES

Designed for discerning musicians, with 36 Sabian B8 Bronze and Aluminum Alloy Bar Chimes tied to a gorgeous Appalachian Red Oak board using braided 50lb line. The combination of B8 and Alloy produces a full spectrum of tone with a softening on both ends of the frequency spectrum.
PCHB8AL36

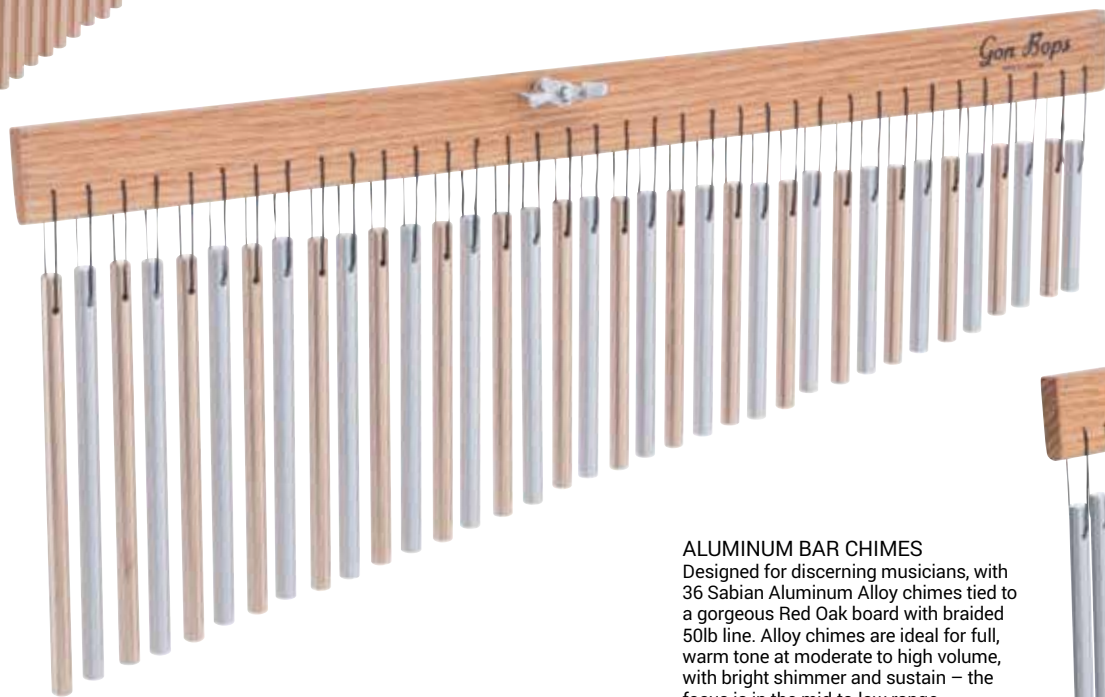

ALUMINUM BAR CHIMES

Designed for discerning musicians, with 36 Sabian Aluminum Alloy chimes tied to a gorgeous Red Oak board with braided 50lb line. Alloy chimes are ideal for full, warm tone at moderate to high volume, with bright shimmer and sustain – the focus is in the mid-to-low range.
PCHAL36



Triangles

Crafted from Sabian Aluminum Alloy, Fiesta triangles produce warm tone, with bright shimmering sustain. Smartly priced – ideal for schools and ensembles who need the best possible sound on a limited budget.

FSTRI4 | 4"
FSTRI6 | 6"
FSTRI8 | 8"

Ultimate Conga Cradle STRMCC



Fully adjustable to fit any conga drum, in any situation. Features extruded ultra-lightweight aluminum design, independent leg adjustment and variable height adjustment, making it the perfect on-the-go cradle. Unique self-aligning feet with non-skid rubber coating keep you stable on uneven surfaces. Folds flat for easy packing.

Double Conga Stand ST3CG2

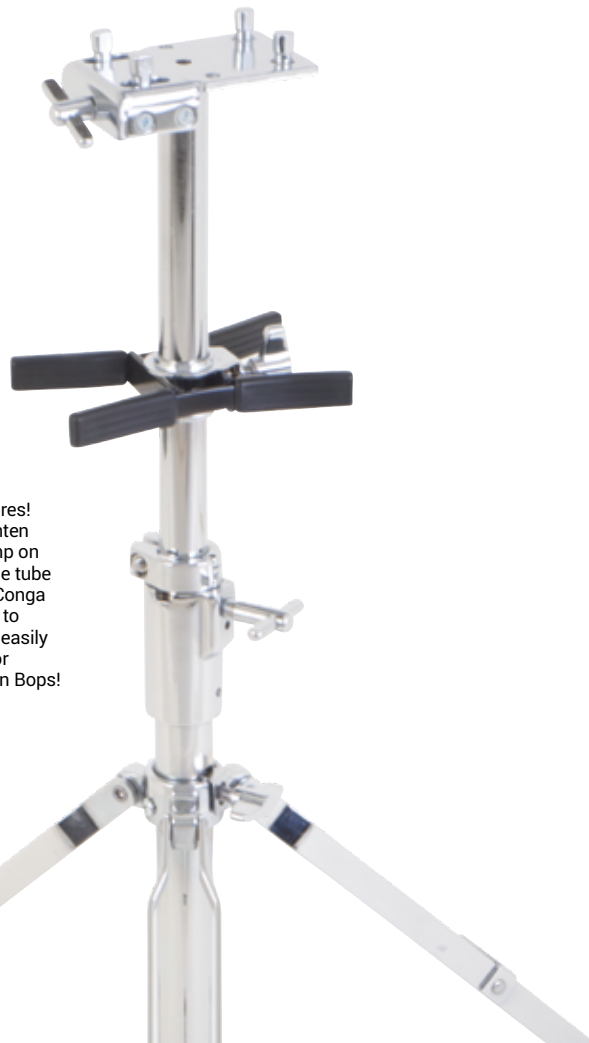

A rock-solid stand loaded with innovative features! Patented Push-Lock™ system allows you to tighten or release drums with one wing-nut. Extra clamp on dual-locking Mega-Tripod™ base locks the inside tube for maximum stability. Patented Self Aligning Conga Bracing system features rubber-coated braces to grip conga surface without scratching and the easily adjustable sliding mechanism compensates for various conga sizes and shapes. Only from Gon Bops!

Bongo Stands



BONGO STAND
ST3BG

LOW BONGO STAND
ST3BGS

A rock-solid stand loaded with innovative features! Extra clamp on Mega-Tripod™ base locks the inside tube for maximum stability and allows for extra-large footprint. Bongo angle is easily adjusted with the large reset handle on the toothless adjustment tilter, and double-locked with TechLock™. Only from Gon Bops!

Timbale Stand ST3TB



A rock-solid stand loaded with innovative features! Patented Push-Lock™ system allows you to tighten or release each drum with one wing-nut. The X-Pand™ Quick-Release Ratchet Cowbell Holder positions bells and blocks in a wide array of configurations. Extra clamp on dual-locking Mega-Tripod™ base locks the inside tube for maximum stability. Only from Gon Bops!



Conga Racks



RK3



RK2

Our high-performance racks and stands are designed to meet the needs of the most demanding, professional musicians and studios. Designed from heavy-duty components for ultimate stability and durability. Available in dual and triple conga configurations.

Fiesta Stands

FIESTA DUAL
CONGA STAND
STFSCG



Fiesta Stands provide legendary Gon Bops quality and durability at a smart price. Lightweight and easy to set-up, they are strong enough for working players on a budget.

FIESTA BONGO
STAND
STFBSG

Djembe Stand STDJ2



Strong, lightweight and easy to set-up, this stand is designed to hold Djembes from 10" – 14" in traditional playing position. A rugged nylon strap holds the djembe tightly, allowing no movement during performances, and padded rubber hooks fit into the bottom of shell without causing damage. Stand can be angled and is fully height-adjustable.



Timbale Hardware Set TBHWSET

A complete solution for mounting bells, blocks, cymbals, and more to your Timbale set—as used by Master Timbalero Luisito Quintero. No timbale player should be without this premium-quality set!



Timbale Stick Pouch TBSTBG

A rugged pouch that keeps sticks, brushes and mallets within easy reach. It mounts to any stand up to 1.5" in diameter, and the tough Velcro fasteners make it quick and easy to set up and tear down.



Percussion Mounts

A durable, versatile mount to get bells, blocks and other percussion instruments mounted to your bass drum quickly and securely.



BASS DRUM
PERCUSSION
MOUNT
BDCM

PERCUSSION MOUNT
SMPMR



A smartly-designed mounting solution includes a straight rod for hand percussion and a threaded angle rod for cymbals and microphones.

FIESTA BASS DRUM
PERCUSSION MOUNT
FSBDPM



A budget version of our Bass Drum Percussion Mount

Percussion Stand/Percussion Tray



PTRAYSTD

Lightweight molded plastic design with quality, non-slip rubber surface. Percussion Stand includes lightweight stand. Percussion Tray includes heavy-duty clamp.



PTRAYSM

Cajon Seat Pad CJSPAD2



A comfortable non-slip seat for long sessions, multiple pockets for brushes, mallets and more, and excellent protection from scratches and scrapes. And no noisy Velcro that can bleed into stage and studio mics!



Cajon Duffel Bag BCJDF

The perfect bag for percussionists or drummers with a set-up based around a cajon or cajon kit. Includes a cajon compartment, a cymbal sleeve, a roomy percussion pocket that also fits a small snare, and top straps to securely attach a cymbal or hi-hat stand. Constructed from fully-padded, water-resistant fabric with smooth-lined interior, this bag offers excellent protection for your valuable instruments.



Bongo Duffel Bag BBGDF

The ideal bag for transporting your bongo! Includes a divider that allows you to carry additional percussion instruments without the possibility of scratching your drum. Constructed from fully-padded, water-resistant fabric with silky-smooth lined interior, this bag offers excellent protection for your valuable instruments.



Bar Chimes Bag BPCH

Specifically designed for Gon Bops Ergo Chimes, but the included soft pillow padding can be used to fit virtually any other chimes. A great solution that offers excellent protection when transporting or storing your bar chimes.



GBCAT21

GonBops.com

 [Instagram.com/GonBopsOfficial](https://www.instagram.com/GonBopsOfficial)

 [Facebook.com/GonBops](https://www.facebook.com/GonBops)

 [YouTube.com/GonBopsTube](https://www.youtube.com/GonBopsTube)

Gon Bops Inc. PO Box 693, Houlton, ME 04730

Gon Bops™

A DIVISION OF

SABIAN 