



# Current status of the asteroid explorer, Hayabusa2, leading up to arrival at asteroid Ryugu in 2018

June 7<sup>th</sup>, 2018

JAXA Hayabusa2 Project



# Today's Topics

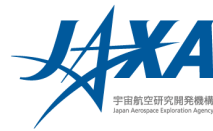

For the Hayabusa2 spacecraft:

- Completion of ion engine operation
- Optical navigation
- Future schedule



# Contents



0. Hayabusa2 mission overview
1. Current status and project schedule
2. Ion engine operation
3. Optical navigation
4. Mission schedule
5. Other topics
6. Future plans



# Overview of Hayabusa2



## Objective

We will explore and sample the C-type asteroid Ryugu, which is a more primitive type than the S-type asteroid Itokawa that Hayabusa explored, and elucidate interactions between minerals, water, and organic matter in the primitive solar system. By doing so, we will learn about the origin and evolution of Earth, the oceans, and life, and maintain and develop the technologies for deep-space return exploration (as demonstrated with Hayabusa), a field in which Japan leads the world.

## Expected results and effects

- By exploring a C-type asteroid, which is rich in water and organic materials, we will clarify interactions between the building blocks of Earth and the evolution of its oceans and life, thereby developing solar system science.
- Japan will further its worldwide lead in this field by taking on the new challenge of obtaining samples from a crater produced by an impacting device.
- We will establish stable technologies for return exploration of solar-system bodies.

## Features:

- World's first sample return mission to a C-type asteroid.
- World's first attempt at a rendezvous with an asteroid and performance of observation before and after projectile impact from an impactor.
- Comparison with results from Hayabusa will allow deeper understanding of the distribution, origins, and evolution of materials in the solar system.

## International positioning:

- Japan is a leader in the field of primitive body exploration, and visiting a type-C asteroid marks a new accomplishment.
- This mission builds on the originality and successes of the Hayabusa mission. In addition to developing planetary science and solar system exploration technologies in Japan, this mission develops new frontiers in exploration of primitive heavenly bodies.
- NASA too is conducting an asteroid sample return mission, OSIRIS-REx (launch: 2016; asteroid arrival: 2018; Earth return: 2023). We will exchange samples and otherwise promote scientific exchange, and expect further scientific findings through comparison and investigation of the results from both missions.



(Illustration: Akihiro Ikeshita)

## Hayabusa 2 primary specifications

Mass	Approx. 609 kg
Launch	3 Dec 2014
Mission	Asteroid return
Arrival	2018
Earth return	2020
Stay at asteroid	Approx. 18 months
Target body	Near-Earth asteroid Ryugu

## Primary instruments

Sampling mechanism, re-entry capsule, optical cameras, laser altimeter, scientific observation equipment (near-infrared, thermal infrared), impactor, small rovers



# Outline of mission flow



**Launch**  
December 3<sup>rd</sup>, 2014



**Asteroid arrival**  
June 27<sup>th</sup>, 2018 (planned)



▲  
Earth swing-by  
December 3<sup>rd</sup>, 2015

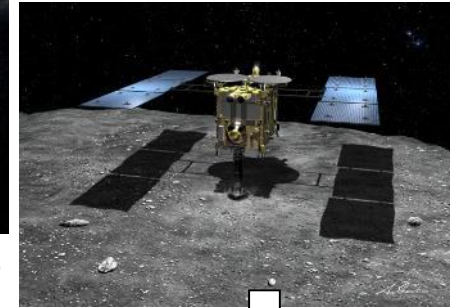

Examination of asteroid via remote sensing observations, followed by the release of the small lander and rovers. Obtain samples from the asteroid surface.

**Return to Earth**  
End of 2020



**Departure from the asteroid**  
November – December, 2019



Create artificial crater

Release impactor

After confirming site safety, touchdown to the crater to collect subsurface material

Create an artificial crater on the asteroid surface using an impactor device.

Sample analysis



# 1. Current status and project schedule

Current status :

- The distance between Ryugu and the spacecraft is about 2100km as of today (June 7)
- On June 3, ion engine operation was completed.
- Arrival at Ryugu is scheduled around June 27.
- Optical navigation is being used on the approach to Ryugu.

Schedule overview :

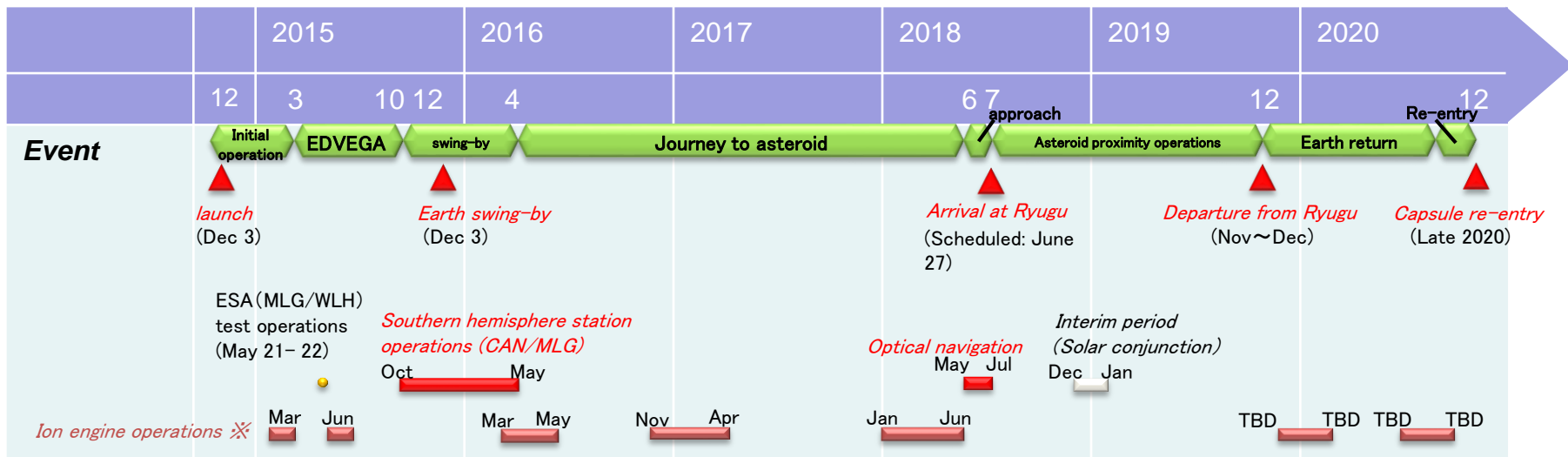



# 2. Ion engine operation

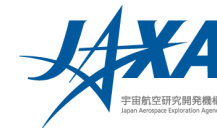

- The third phase of ion engine operation began on January 10, 2018 and was completed on June 3 at 14:59 JST. The velocity increase was 393 m/s.
- This completes the forward cruise ion engine operation.
- During the forward cruise, 24 kg of xenon propellant were consumed, leaving 42 kg remaining.
- Total increase in speed for the forward cruise is about 1015 m/s.

History of thrust from the ion engine system (IES)

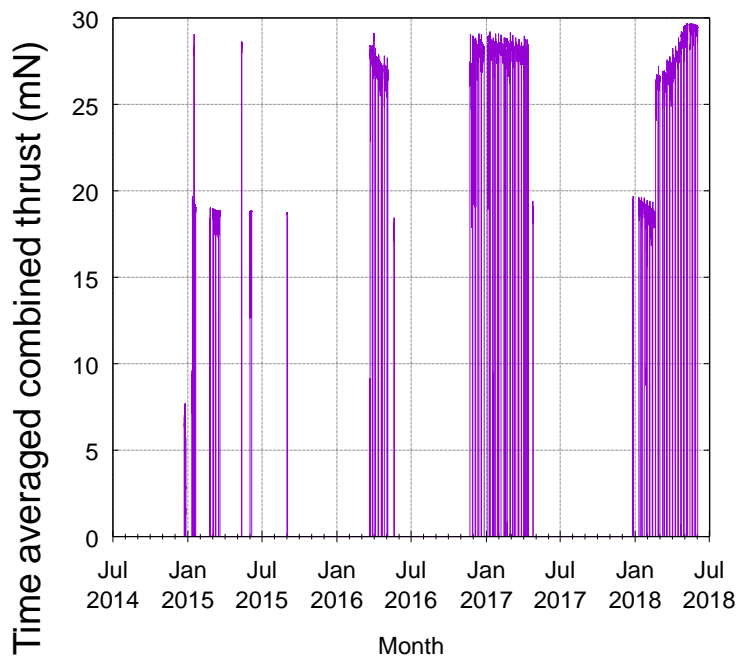

Includes operation test. "IES" refers to one or more thrusters

	Thruster	Hayabusa2	Hayabusa
Cumulative operation time (hours)	A	6450	7
	B	11	12809
	C	5193	11989
	D	6418	14830
	IES	6515	25590
	Total	18073	39635
Total power production (MN·s)	A	0.2174	0.0001
	B	0.0002	0.3221
	C	0.1735	0.2639
	D	0.2191	0.3613
	IES	0.6102	0.9474
Maximum thrust (mN)	A	10.03	7.42
	B	7.61	8.36
	C	10.08	8.30
	D	10.16	7.95
	IES	29.67	24.12



## 2. Ion engine operation

- Experience from Hayabusa allowed the frequency of unplanned stops of ion engine operation (from automatic safety procedures) to be greatly reduced and the stable operation time improved via appropriate selection of the monitoring settings.
  - Hayabusa 68 times /25590 hours → average 376 hours
  - Hayabusa2 4 times /6515 hours → average 1629 hours
- Ground tracking time was reduced by 35% compared to Hayabusa, making operation more efficient.

Ratio of ground tracking time to powered navigation time:

- Hayabusa 5059 hours /25590 hours = 20%
- Hayabusa2 850 hours / 6515 hours = 13%

A shortened “half-pass” for just four hours a day was frequently used while operations 5 – 6 times a week were continued. This shortened time is due to good results from the spacecraft, including the ion engine operation and improvements in the orbit determination technique from radio navigation.





# 2. Ion engine operation

## Summary of forward cruise ion engine operation

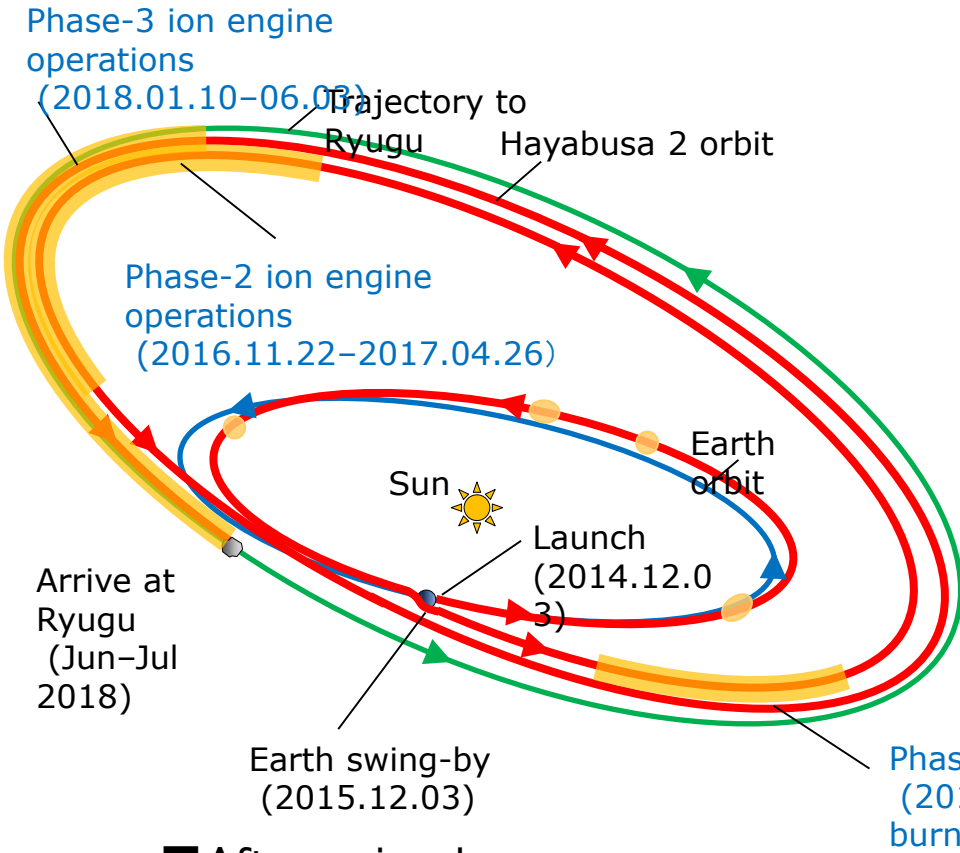

### Before swing-by

Period	Name	No. of thrusters	$\Delta v$ m/s	Time h
Initial check	IES operations test	-	-	-
2015.03.03-21	IES Powered Navigation 1	2	44	409
2015.05.12-13	IES max. thrust test	3	4	24
2015.06.02-06	IES Powered Navigation 2	2	11	102
2015.09.01-2	IES Powered Navigation 3	2	1.3	12

IES: ion engine system

Because there was a different between the initially reported value and the engineering database stored value

2018/6/7 correction

### After swing-by

Period	Name	No. of thrusters	$\Delta v$ m/s	Time
2016/3/22~2016/5/21	Phase 1: Ion engine operation	3 (2 at times)	127	798 h
2016/11/22~2017/4/26	Phase 2: ion engine	3 (2 at times)	435	<del>2558</del> 2593
2018/1/10~2018/6/3	Phase 3: ion engine	2→3	393	<del>2426</del> 2475



### 3. Optical navigation

- Optical navigation (precisely “hybrid navigation using optical and radiometric observations”) is a method of approaching a target celestial body using a camera (or similar device) mounted on a spacecraft.
- This technique is essential for Hayabusa2 to arrive at Ryugu.
- Radio navigation alone is not precise enough to arrive at the 1km asteroid Ryugu at a distance of 300 million km from Earth.

Reason: The error in the Ryugu’s position was about 220km at the beginning of May 2018. (Error of  $3\sigma$  or 99.7% probability.)

Note: The position of the spacecraft can be estimated within an error of several km from a 300 million km distance by a technique called DDOR (Delta Differential One-way Range).

※ DDOR technology was not used in the case of Hayabusa, so the error on the spacecraft position was big. However, radar observations of Itokawa were possible, so the asteroid orbit was more accurately known. This meant that it was necessary for us to use optical navigation for Hayabusa to arrive at Itokawa.



# 3. Optical navigation

## Optical navigation using the STT (Star Tracker)

- In May, ion engine operation was ongoing, making it impossible to point the Optical Navigation Camera at Ryugu. Instead, an image of Ryugu was attempted with the Star Tracker, which is usually used to determine the orientation of the spacecraft.
- From the position of Ryugu imaged, more accurate orbits of the spacecraft and asteroid were estimated.
- The distance from the spacecraft to Ryugu is about 70,000km and the asteroid has the brightness of a 5<sup>th</sup> magnitude star.

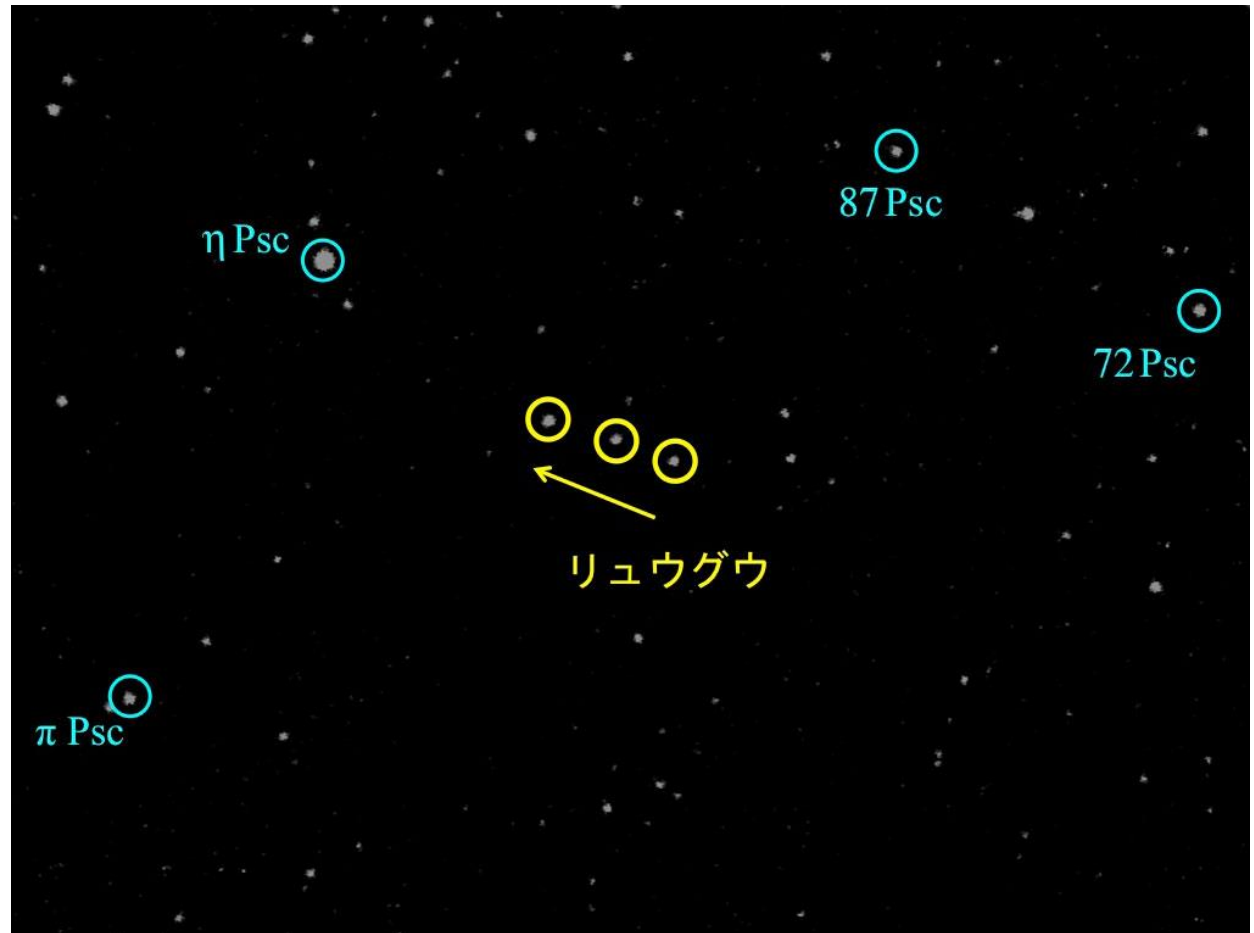

Photograph of Ryugu using the Star Tracker. From the right, the images were taken at around 01:00 on May 12, 02:00 on May 13 and 01:00 on May 14 (JST). These are taken from the spacecraft in the direction of Pisces. ("Psc" is an abbreviation of Pisces.) The field of view is 9° × 7° . (Image credit: JAXA, Kyoto University, Japan Spaceguard Association, Seoul National University.)



# 3. Optical navigation

## Optical navigation using the ONC (Optical Navigation)

- From June 5, the ONC (T and W1) photographed Ryugu to attempt optical navigation.
- The picture on the right was taken on June 6, around 04:15 JST in the direction of Ryugu.
- The distance to Ryugu is about 2600km.
- The brightness of Ryugu is about -5 magnitudes.
- Because the exposure time was as long as 178 seconds, Ryugu is bright and blurred (the purpose was to image the background stars.)

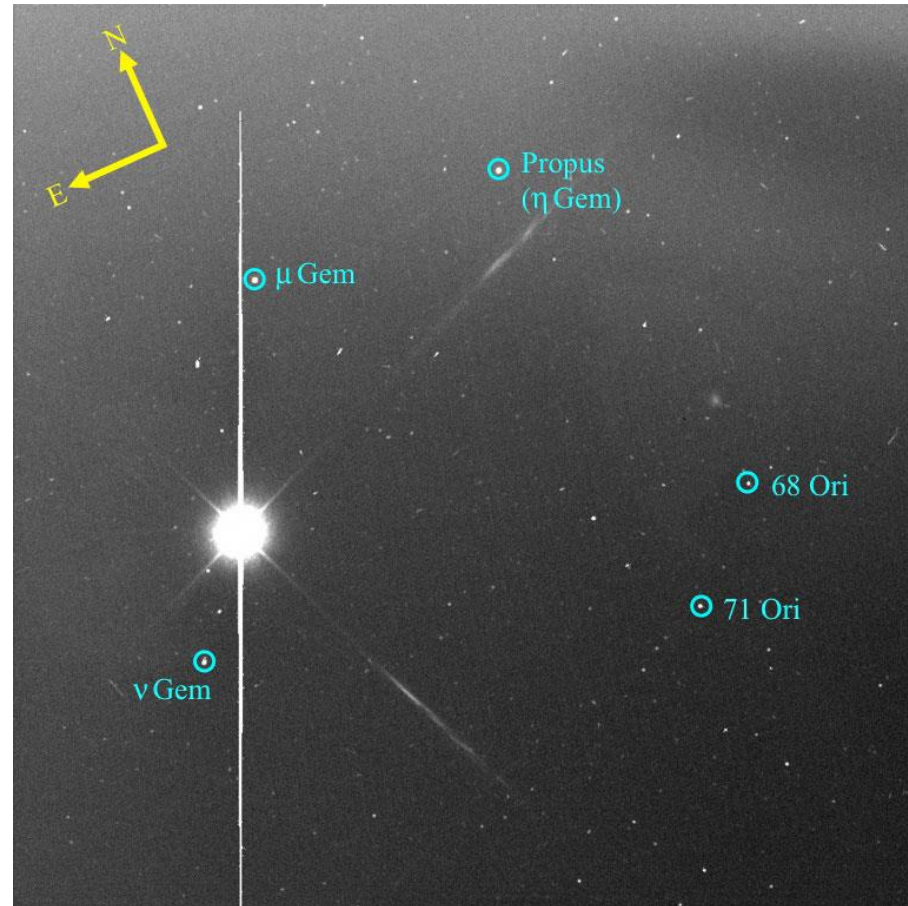

Ryugu imaged by the ONC-T. The photograph was taken around 04:15 JST on June 6, 2018. The field of view is 6.3 degrees x 6.3 degrees. Exposure time is 178 seconds. Ryugu is located in the constellation of Gemini (Gem).  
Ground observation team: JAXA, Kyoto University, Japan Spaceguard Association, Seoul National University.  
ONC team: JAXA, University of Tokyo, Kochi University, Rikkyo University, Nagoya University, Chiba Institute of Technology, Meiji University, University of Aizu, AIST



# 3. Optical navigation

## Optical navigation using the ONC (Optical Navigation)

- Image with an exposure time of about 0.09 seconds.
- Only asteroids appear as points.
- The image is about 3 pixels in diameter.
  - 1 pixel = about 22 arc seconds
  - = about 0.3 km@2600km
- The shape is still unknown.

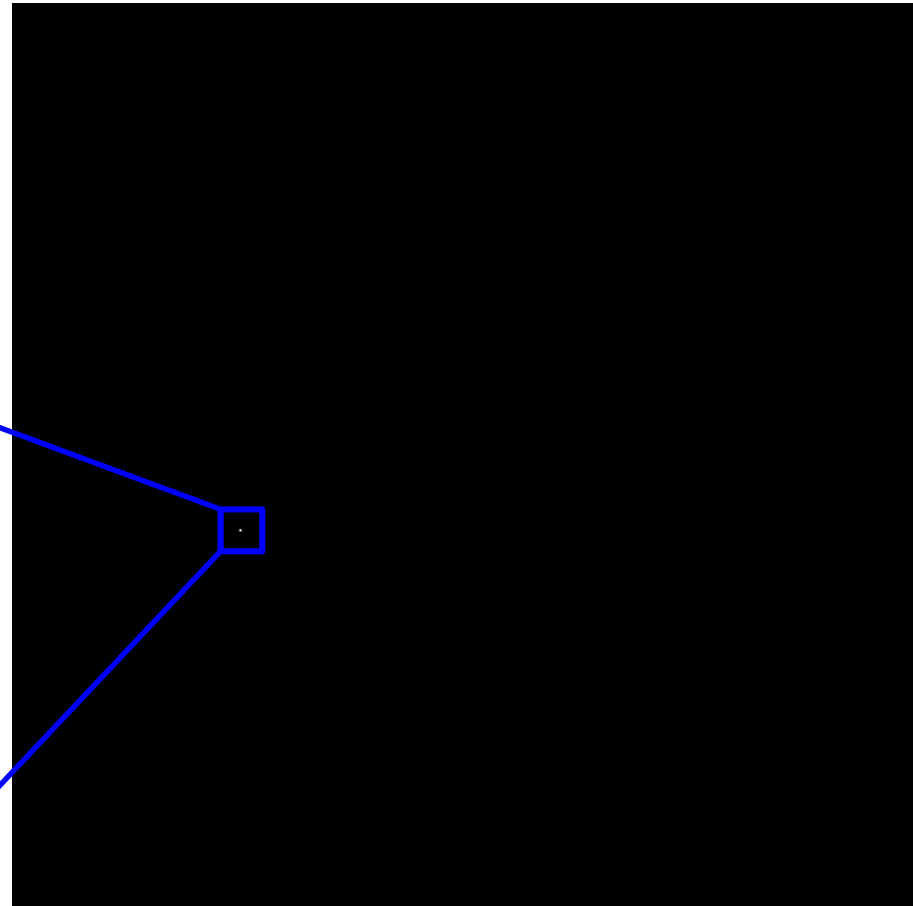
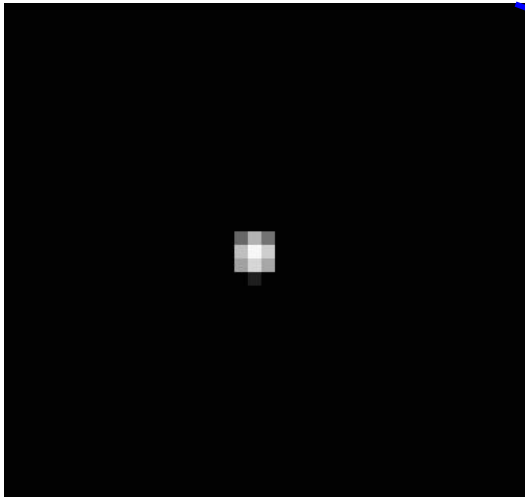

Ryugu imaged by the ONC-T. The photograph was taken around 04:15 JST on June 6, 2018. The field of view is 6.3 degrees x 6.3 degrees. Exposure time is approximately 0.09 seconds.  
Ground observation team: JAXA, Kyoto University, Japan Spaceguard Association, Seoul National University.  
ONC team: JAXA, University of Tokyo, Kochi University, Rikkyo University, Nagoya University, Chiba Institute of Technology, Meiji University, University of Aizu, AIST



## 4. Mission schedule



Most recent operations:

- June 3: Start of asteroid approach

Continue optical navigation until asteroid arrival

A detailed report will be available at the press briefing on June 14

- Arrival at Ryugu is scheduled for around June 27 (this may vary by several days, depending on actual operations).

Operations in the asteroid vicinity:

- The exact schedule will be determined by observations between June – August.
- The schedule at the present time is shown on the next slide.



# 4. Mission schedule

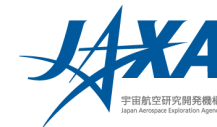

Provisional version

Year	Month, day	Event	Status
2018	January 10	Third stage of ion engine operation begins	Complete
	June 3	Ion engine operation ends	Complete
	June 3	Start of asteroid approach (distance: 3100km)	Complete
	June 27	Arrival at asteroid Ryugu (altitude 20km)	Planning
	End of July	Medium altitude observations #1 (alt. 5km)	Planning
	August	Decent to measure gravity (alt.1km)	Planning
	Sept – Oct	Period for touchdown operation #1	Planning
	Sept – Oct	Period for rover deployment #1	Planning
	Nov – Dec	Solar conjunction (communication unavailable)	Planning
2019	January	Medium altitude observations #2 (alt. 5km)	Planning
	February	Period for touchdown operation #2	Planning
	Mar – Apr	Crater generation operation	Planning
	Apr – May	Period for touchdown operation #3	Planning
	July	Period for rover deployment #2	Planning
	Aug – Nov	Remain near asteroid	Planning
	Nov – Dec	Departure from asteroid	Planning

This schedule may be changed for multiple factors after arrival at Ryugu. Please note therefore, that the situation is not fixed, except where marked ‘Complete’.



# 5. Other

## Outreach & other activities

### ■ “Imagining Ryugu” contest

- 18 domestic nodes, 7 from overseas
- Number of submissions:  
1819 domestic (unreported nodes: 1)  
150 overseas (unreported nodes: 1)
- Project members also created imaginary suggestions.  
(In Japanese: <http://www.hayabusa2.jaxa.jp/topics/20180605/>)

### ■ Hayabusa2 “ask any question” box (Japan Planetary Society)

- We am to collect as many possible questions and answers for the project, so that as many people as possible can know about Hayabsua2.  
(In Japanese: <http://planetary.jp/hayabusa2/FAQ/index.html>)





## 6. Future plans



Media correspondence, information disclosure:

- Next press conference is scheduled for the morning of June 14 (@ the Tokyo Office).
- Arrival at 20km above Ryugu is scheduled for around June 27. At this time, a press release will be posted and press briefing (@ the Sagamihara campus) will be scheduled.
- We plan to hold regular press briefings after July.
- The spokespeople for the Hayabusa2 Project are Professor Kobota and Associate Professor Yoshikawa, JAXA Institute of Space and Astronautical Sciences. They will accept interview requests regarding Hayabusa2.



# Reference material



# Primary spacecraft components

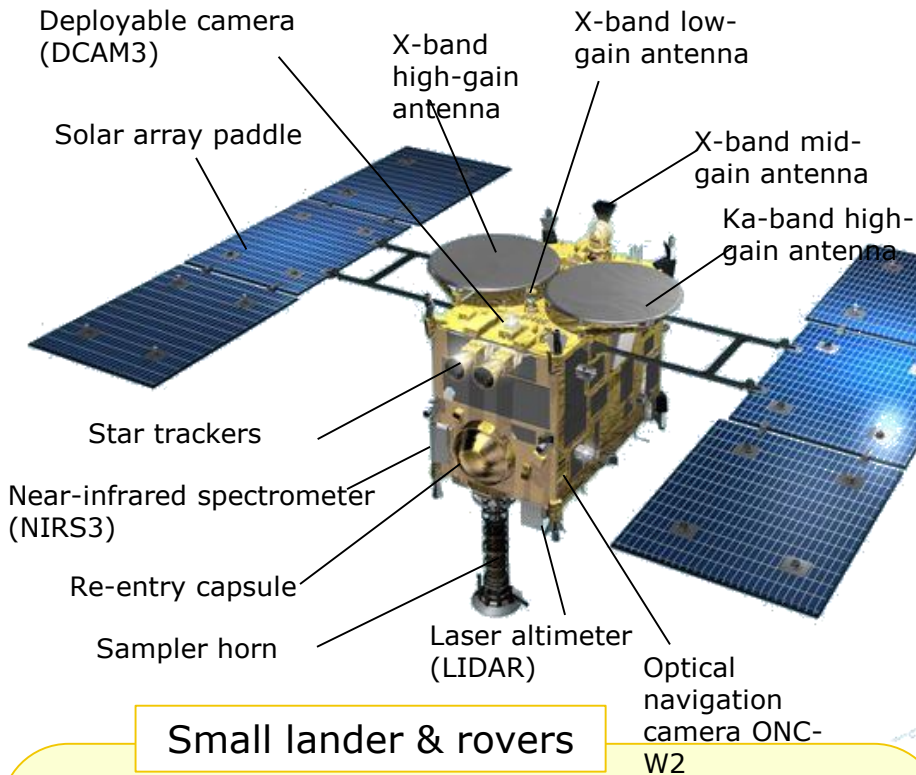
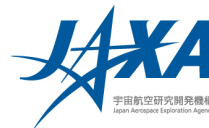

Optical navigation camera, ONC-T

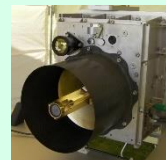

laser altimeter, LIDAR

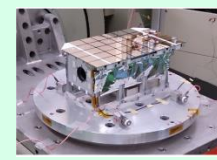

Near-infrared spectrometer, NIRS3

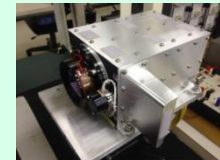

Thermal infrared camera, TIR

## Scientific observation equipment

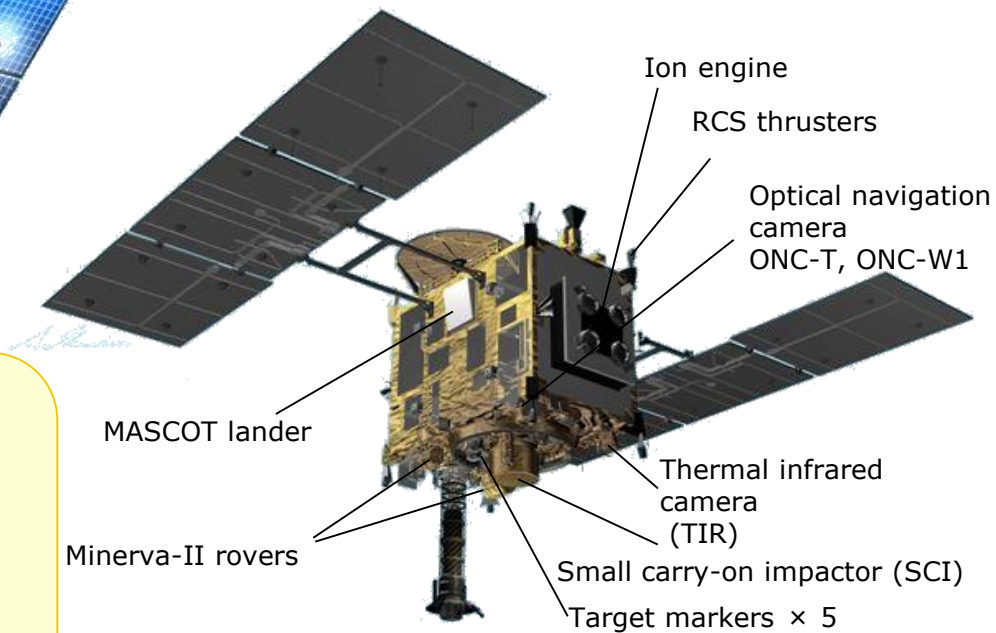

## Small lander & rovers

### MASCOT



Built by DLR and CNES

### Minerva 2

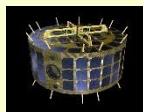

II-1A

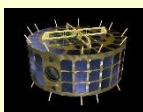

II-1B

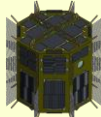

II-2

II-1: By the JAXA Minerva-II team

II-2: By Tohoku Univ. & the Minerva-II Consortium

Size: 1 × 1.6 × 1.25 m (main body)  
Solar paddle deployed width 6

Mass : 609 kg (incl. fuel)



# Electric propulsion (ion engine)

- Name:  $\mu 10$   
Microwave discharge-type ion engine with 10cm diameter  
This was named after the ISAS mu rocket.
- Converts xenon\* into plasma (ions), which is accelerated by applying a voltage.
- A microwave discharge system is used to generate ions.
- Four units are mounted, and simultaneous operation of three generates thrusts of up to 30 mN.
- Approximately 66 kg of loaded xenon fuel, allowing a velocity increase of up to 2 km/s.

- \*Why we use xenon
- Used to alter trajectories when cruising from Earth to the asteroid and back.
- Xenon is a monoatomic molecule, so its ionization voltage is smaller than that of gas comprising of two or more atoms. This increases the ratio of added energy that is used for acceleration.
- It is easy to fill the tank at high density (density 1.2 – 1.5)
- Reactivity is lower than that of other substances.
- Mass (atomic weight) is large, improving the efficiency of acceleration.



Injection test in a flight model vacuum chamber

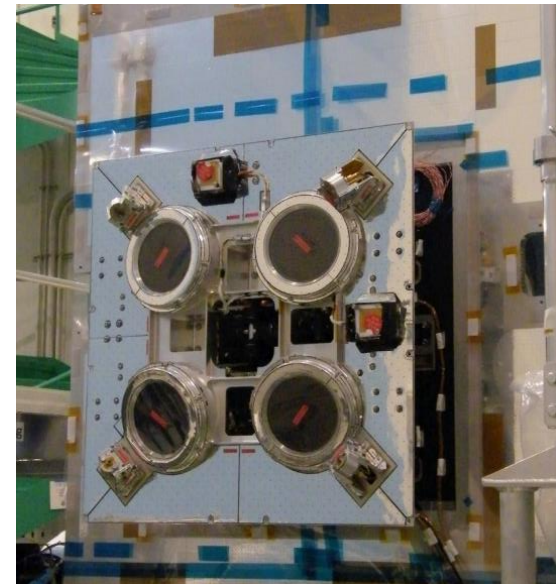

Hayabusa2 ion engine



# Reference: How ion engines work

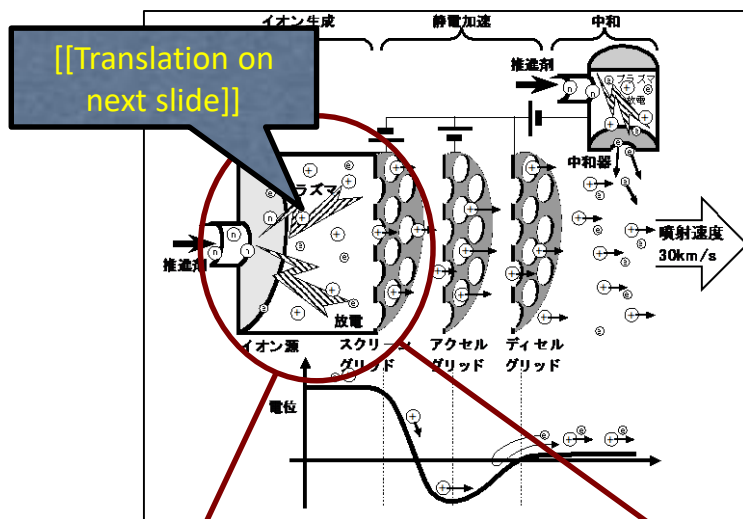
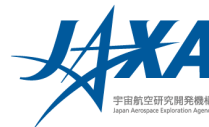

Source: *Dynamic Navigation with Ion Engines (Space Engineering Series 8)*, Corona Publishing (2006)

## Different ion generation systems

DC discharge

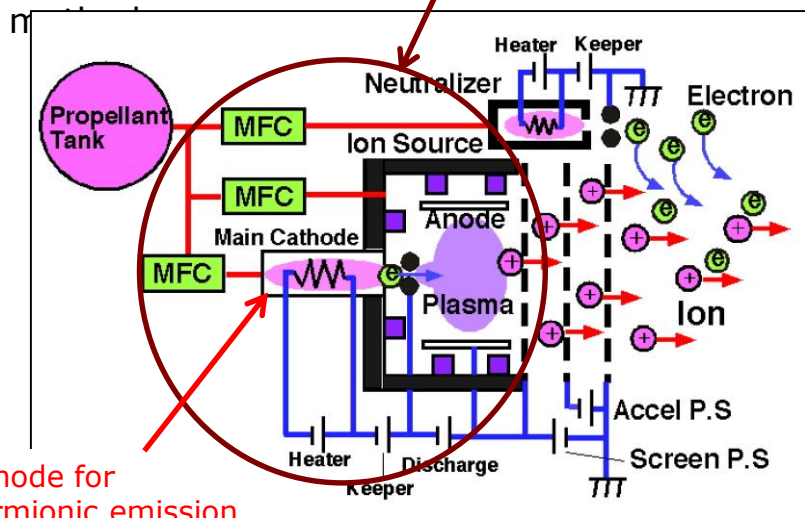

Cathode for thermionic emission

Note: The ion engine developed in the U.S., the U.K. and the former NASDA was a DC discharge Kaufman-type ion engine or a Ring-Cusped ion engine.

Microwave discharge method

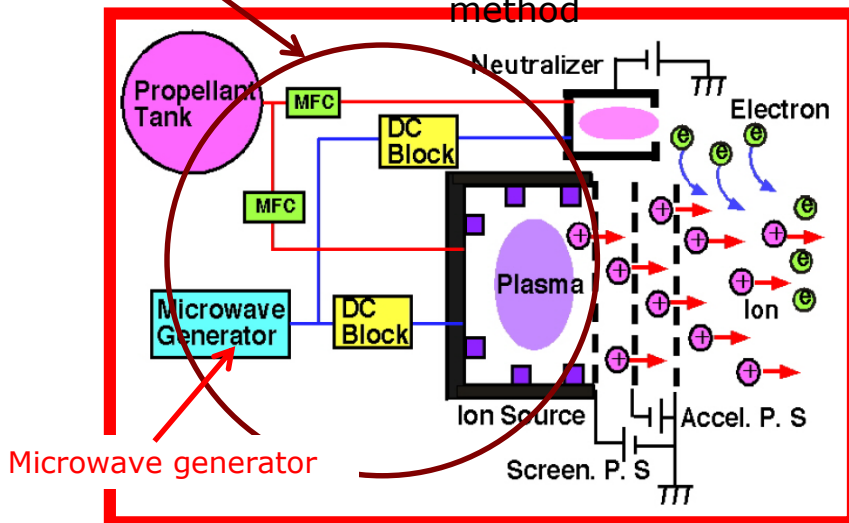

Microwave generator

Note: The ion engine developed at the ISAS in Japan is a microwave discharge-type ion engine.

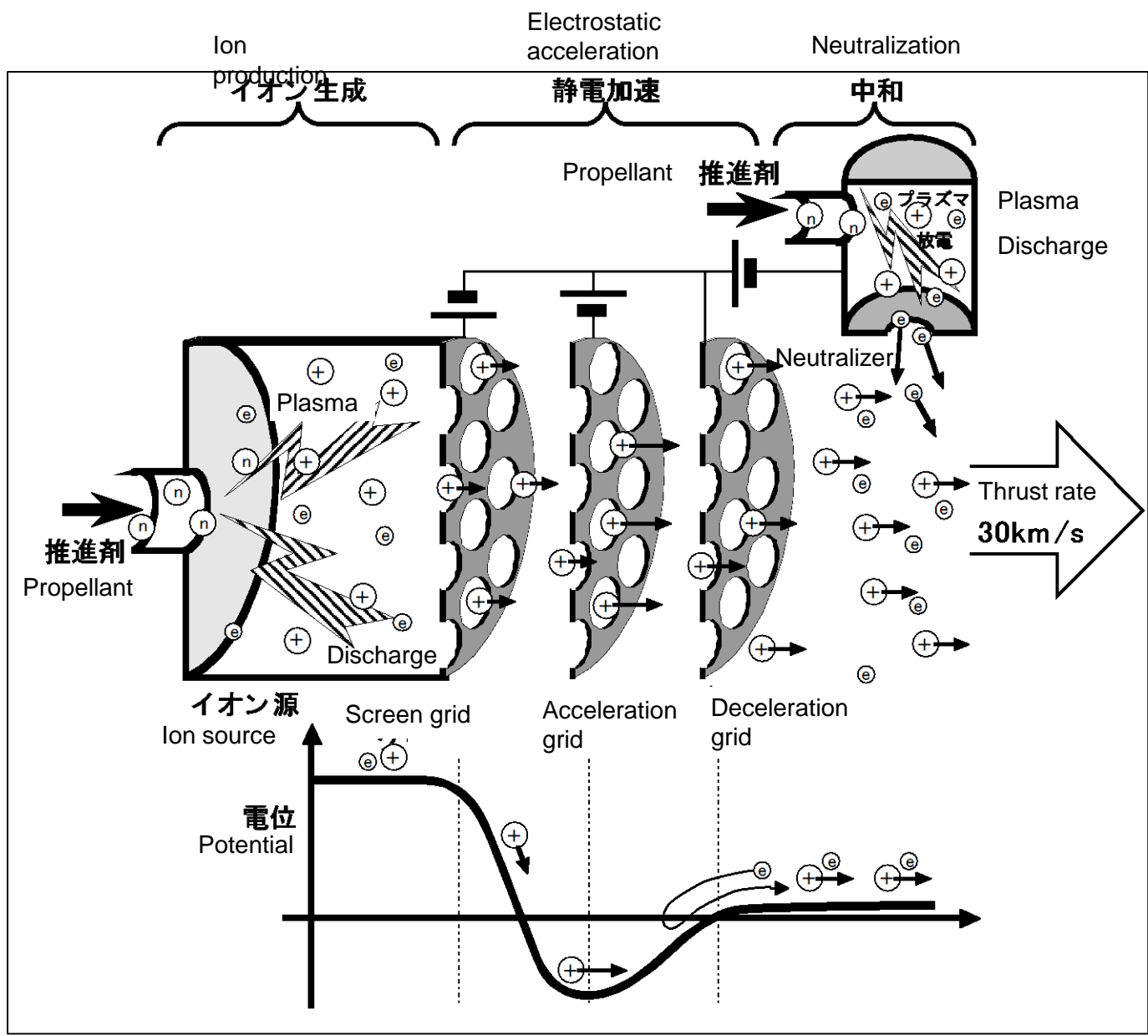



# Remote sensing equipment



## Optical Navigation Camera (ONC)

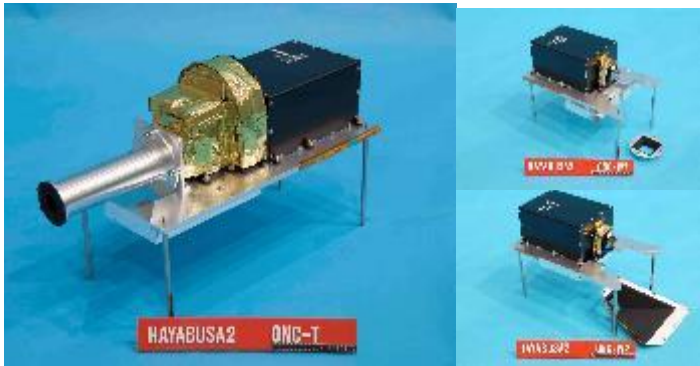

ONC-T (telephoto) ONC-W1,W2 (wide-angle)

Imaging for scientific observation and navigation

## Thermal Infrared Camera (TIR)



8–12  $\mu\text{m}$  imaging: Measures asteroid surface temperature

## Near-infrared Spectrometer (NIRS3)

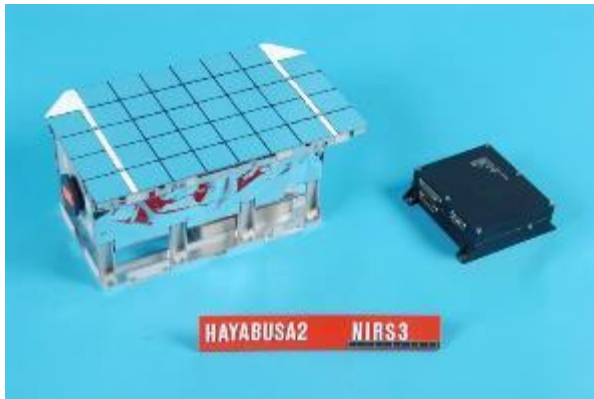

Infrared spectra including the 3- $\mu\text{m}$  band: investigates mineral distributions on the asteroid surface

## Laser Altimeter (LIDAR)



Measures distance between the asteroid and the spacecraft in a range of 30 m–25 km



# Optical Navigation Camera (ONC)



## ONC: Optical Navigation Camera



**Objective:** Images fixed stars and the target asteroid for spacecraft guidance and scientific measurements

**Scientific measurements:**

- Form and motion of the asteroid:
  - Diameter, volume, direction of inertial principal axis, nutation
- Global observations of surface topography
  - Craters, structural topography, rubble, regolith distribution
- Global observations of spectroscopic properties of surface materials
  - Hydrous mineral distribution, distribution of organic matter, degree of space weathering
- High-resolution imaging near the sampling point
  - Size, form, degree of bonding, and heterogeneity of surface particles; observation of sampler projectiles and surface markings

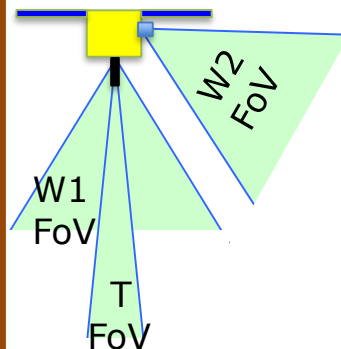
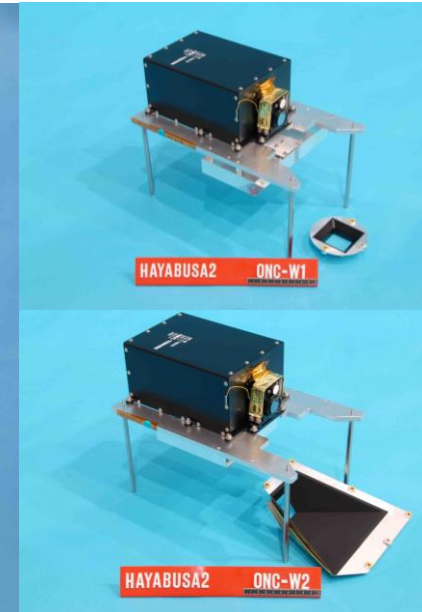
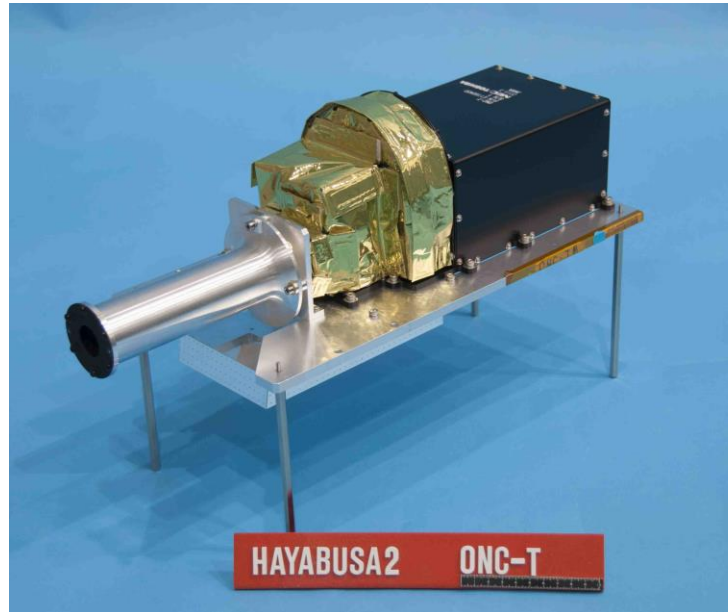

- Elucidation of features of target asteroid
- Distribution of **hydrous minerals and organic matter**, space weathering, boulders
- Sampling site selection
- Basic information on where to collect asteroid samples
- Ascertaining sample state
- **High-resolution imaging** of sampling sites

	ONC-T	ONC-W1	ONC-W2
<b>Detector</b>	2D Si-CCD (1024 × 1024 px)		
<b>Viewing direction</b>	Downward (telephoto)	Downward (wide-angle)	Sideward (wide-angle)
<b>Viewing angle</b>	6.35° × 6.35°	65.24° × 65.24°	
<b>Focal length</b>	100 m–∞	1 m–∞	
<b>Spatial resolution</b>	1 m/px @ 10-km alt. 1 cm/px @ 100-m alt.	10 m/px @ 10-km alt. 1 mm/px @ 1-m alt.	
<b>Observation wavelength</b>	390, 480, 550, 700, 860, 950, 589.5 nm, and wide	485–655 nm	





# Asteroid Ryugu



Name	: Ryugu
Permanent designation	: 162173
Provisional designation	: 1999 JU <sub>3</sub>
Discovered	: May 1999
Size	: Approx. 900 m
Shape	: Nearly spherical
Rotation period	: approx. 7 h 38 min
Rotation orientation	: Ecliptic longitude $\lambda = 310^\circ - 340^\circ$ Ecliptic latitude $\beta = -40^\circ \pm -15^\circ$
Reflectivity	: 0.05 (blackish)
Type	: C type (assumed to comprise materials containing water and organics)
Orbital radius	: Approx. 180,000,000 km
Orbital period	: Approx. 1.3 yr
Density and mass	: Density is currently unknown, but presumed to be 0.5–4.0 g/cm <sup>3</sup> : Mass is approx. $1.7 \times 10^{11}$ kg – $1.4 \times 10^{12}$ kg.

## Orbit of Ryugu



## Estimated shape

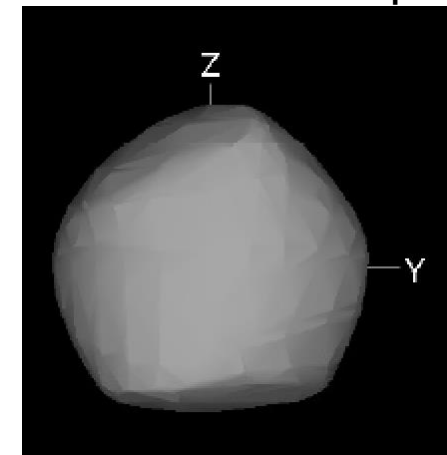

(by T. Mueller)