

Maui Smart Grid Demonstration Project

**Managing Distribution System Resources for Improved
Service Quality and Reliability, Transmission Congestion
Relief, and Grid Support Functions**

Final Technical Report

Prepared for the

**U.S. Department of Energy
Office of Electricity Delivery and Energy Reliability**

**Under Award No. DE-FC26-08NT02871
Renewable and Distributed Systems Integration Program**

Prepared by the

**Hawai'i Natural Energy Institute
University of Hawai'i at Mānoa
School of Ocean and Earth Science and Technology**

December 2014



**UNIVERSITY
of HAWAII®
MĀNOA**



ACKNOWLEDGEMENTS

This material is based upon work supported by the U.S. Department of Energy (DOE) under Cooperative Agreement Number DE-FC26-08NT02871.

Chris Reynolds of Maui Electric Company (MECO) was an essential contributor to this project. From the beginning, he made sure the project was relevant by aligning the project's scope and objectives to key issues facing MECO and its commitment to customer service. Chris oversaw the functional specifications of the systems, conducted technical due diligence during vendor procurement, coordinated activity among MECO departments, participated in all factory and site acceptance tests, and directed performance tests that provided results and information directly relevant to MECO's operating and planning needs. This project included MECO's first battery energy storage installation, of which Chris personally oversaw all aspects, including: specification, procurement, site preparation, commissioning, and performance testing. Ryan Hashizume of MECO was also a key individual who integrated the distribution management system (DMS) with MECO's Supervisory Control and Data Acquisition (SCADA) system, including implementation of a cyber-secure data processing system and historian (T-REX) that proved instrumental in enabling performance data from the project to be extracted, analyzed, and integrated with SCADA data.

Contributors from Hawaii Natural Energy Institute (HNEI) included Leon Roose (Principal Investigator), James "Christian" Rawson, Dr. James "Jay" Griffin, Dr. Terrence "Terry" Surles, Marc Matsuura, Nathan Liang, Edwin Noma, Reza Ghorbani, Ehsan Reihani, Saeed Sepasi and Ashkan Zeinalzadeh. Eileen Peppard of University of Hawaii (UH) managed data collection and warehousing, making analysis of the performance data possible. She was assisted by Daniel Zhang, David Wilkie, and Christian Damo. Other key contributors were Larry Markel and Chris O'Reilley from SRA/Sentech; Willow Krause and Lory Basa of Maui Economic Development Board (MEDB) and Jennifer Chirico of The Sustainable Living Institute of Maui (SLIM) at the University of Hawaii Maui College (UHMC); Joseph Feind and Darren Ishimura of Hawaiian Electric Company (HECO); and Ellen Nashiwa, Scott Kelly and Ron Takemoto of MECO.

Disclaimer: This report was prepared as an account of work sponsored by an agency of the U.S. Government. Neither the U.S. Government nor any agency thereof, nor any of their employees, makes any warranty, express or implied, or assumes any legal liability or responsibility for the accuracy, completeness, or usefulness of any information, apparatus, product, or process disclosed, or represents that its use would not infringe privately owned rights. Reference herein to any specific commercial product, process, or service by trade name, trademark, manufacturer, or otherwise does not necessarily constitute or imply its endorsement, recommendation, or favoring by the U.S. Government or any agency thereof. The views and opinions of authors expressed herein do not necessarily state or reflect those of the U.S. Government or any agency thereof.

TABLE OF CONTENTS

ACKNOWLEDGEMENTS	ii
TABLE OF CONTENTS.....	iii
1. SUMMARY	1
2. PROJECT SCOPE AND OBJECTIVES	5
2.1 Project Objectives	5
2.2 Desired Maui-Specific Project Results	6
2.3 Project Location	7
2.4 Primary Functions Implemented	8
3. SYSTEM SPECIFICATION / DESIGN	10
3.1 AMI and Communication Architecture.....	10
3.1.1 Silver Spring Networks (SSN) Data Center (AMI Headend).....	10
3.1.2 AMI System	12
3.1.3 Demand Response Management System (DRMS).....	15
3.1.4 PV Monitoring	15
3.1.5 Distribution Automation	16
3.2 MECO Operations Center	18
3.2.1 Distribution Management Center.....	18
3.2.2 Interface to DRMS and AMI	18
3.3 Cyber Security Architecture.....	18
3.3.1 Defense in Depth Security Approach	18
3.3.2 Cyber Standards	19
3.3.3 Data Security at SSN Facilities.....	19
3.3.4 Cross Domain Security	20
3.4 Distribution Management System.....	20
3.4.1 DMS Change during Budget Period 2	20
3.4.2 DMS System Description	21
3.4.3 DMS Architecture.....	21
3.4.4 DMS Component Description.....	21
3.4.5 Integration with the MECO SCADA System	23
3.4.6 DMS Interfaces	24
4. IMPLEMENTATION SCHEDULE.....	26
5. OUTREACH AND COMMUNICATIONS ACTIVITIES	28
5.1 Customer Recruitment.....	28

5.2	Community Meetings and Outreach Events.....	30
5.2.1	Launching the Project	30
5.2.2	Continuing Communications with Project Volunteers	31
5.2.3	Home Visits	32
5.2.4	Newsletters.....	32
5.2.5	Other Media	33
5.3	Customer Feedback	34
5.4	Workforce Development	34
5.4.1	SLIM Program Goals	34
5.4.2	Energy Audits	35
5.4.3	Student Education Results	36
6	ANALYSIS AND EVALUATION	40
6.1	Analysis Plan.....	40
6.1.1	Overview & Summary	40
6.1.2	Load and Voltage Profile	41
6.1.3	Customer Energy Use	42
6.1.4	PV Profile.....	42
6.1.5	Home Area Network and Customer Web Portal.....	43
6.1.6	Demand Response/Load Control Research and Analysis.....	45
6.1.7	Battery Energy Storage System (BESS).....	53
6.1.8	Distribution Management System (DMS)	58
6.2	Experimental Results.....	61
6.2.1	Demand Response.....	61
6.2.2	Residential Home and PV Load Profiles	63
6.2.3	Customer Energy Use and Web Portal Usage	67
6.2.4	Battery Energy Storage System (BESS).....	81
7.	SUMMARY OF RESULTS, CONCLUSIONS & ACCOMPLISHMENTS	92
7.1.	Overview	92
7.2.	Load, Voltage and PV Profiles	93
7.3.	Customer Energy Use and Smart Meters/In-Home Displays	94
7.4.	Demand Response/Load Control	95
7.5.	Battery Energy Storage System (BESS).....	95
7.6.	Volt/Var Control/DMS	96
7.7.	Overall Project Objectives Accomplished	96

8. LESSONS LEARNED.....	98
8.1. Smart Grid System Design and Technology Options	98
8.2. Customer Interface and Education	100
8.3. MECO Staff Training.....	100
Appendices.....	102
Final Project Management Plan (PMP) & Statement of Project Objectives (SOPO).....	102
Equipment and Software Procured for Maui Smart Grid Demonstration Project	121

1. SUMMARY

The Maui Smart Grid Project (MSGP) is under the leadership of the Hawaii Natural Energy Institute (HNEI) of the University of Hawaii at Manoa. The project team includes Maui Electric Company, Ltd. (MECO), Hawaiian Electric Company, Inc. (HECO), Sentech (a division of SRA International, Inc.), Silver Spring Networks (SSN), Alstom Grid, Maui Economic Development Board (MEDB), University of Hawaii-Maui College (UHMC), and the County of Maui. MSGP was supported by the U.S. Department of Energy (DOE) under Cooperative Agreement Number DE-FC26-08NT02871, with approximately 50% co-funding supplied by MECO.

The project was designed to develop and demonstrate an integrated monitoring, communications, database, applications, and decision support solution that aggregates renewable energy, other distributed generation (DG), energy storage, and demand response technologies in a distribution system to achieve both distribution and transmission-level benefits. The application of these new technologies and procedures will increase MECO's visibility into system conditions, with the expected benefits of enabling more renewable energy resources to be integrated into the grid, improving service quality, increasing overall reliability of the power system, and ultimately reducing costs to both MECO and its customers.

The project had seven primary objectives for applying advanced technologies to the MECO grid in the scope of the project. Distribution-level benefits include:

- D-1: Reduce a distribution system's peak grid energy consumption.
- D-2: Improve voltage regulation and power quality on the selected distribution feeder.
- D-3: Demonstrate that the architecture of the demonstration project is compatible with additional distribution management system functions, customer functions, and legacy systems.
- D-4: Develop and demonstrate solutions to significant increases in distributed solar (photovoltaic systems) technologies.

At the transmission level, the solution will enable coordination of the operation of distributed energy resources (DER) to make the distribution system dispatchable, providing benefits of:

- T-1: Provision for management of short-timescale intermittency from resources elsewhere in the grid, such as wind energy, solar energy, or load intermittency.
- T-2: Provision for management of spinning reserve or load-following regulation.
- T-3: Reduction of transmission congestion (through curtailment of peak load).

Maui, as is true of all of Hawaii, is seeing a tremendous increase in distributed and grid-level renewable energy installations. Operating the grid with high penetrations of as-available renewable energy resources is proving increasingly difficult. There are especially concerns about maintaining the reliability and stability of the grid, maintaining customer voltages within tariff specifications, and determining the amount of operating reserves needed to support the as-available renewable energy resources cost effectively. "Smart grid" technologies and functionality have the potential to address these issues, but before a system-wide "rollout" of a smart grid, MECO desired to obtain more familiarity with costs, capabilities, and operating procedures through a pilot demonstration. Determining appropriate functionality for Advanced Metering Infrastructure (AMI) is especially key. So-called "smart meters" offer many

capabilities to consumers, but before MECO invests in an AMI system, it wanted to determine which of the myriad AMI functions will deliver real value to its customers.

At the beginning of the project, the project team identified key issues and questions:

- Improving visibility into the distribution system; evaluation of methods to acquire, transmit, process and display the information; data resolution and latency requirements. Specific goals included:
 - Data on customer voltages, resulting in better power quality
 - Understanding the impacts of distributed photovoltaic (PV) systems on service voltages
 - Load research – understand how consumption information and PV system installations impact residential energy use
- Determining the amount of PV energy supplied by distributed generation on the system
- Use of Demand Response (DR) to reduce peak load and mitigate variations of as-available renewable energy resources
- Experience with specification, installation, and operation of a Battery Energy Storage System (BESS), including smoothing variability from renewable energy generators and loads
- Identifying “Smart Grid” functions, especially “smart meter” functionality, of most value to MECO customers (in preparation for system-wide smart meter rollout)
- Improved volt/var management
- Determine MECO training and staffing requirements for smart grid implementation and operation (meter shop, installers, system operators, etc.)
- Integration of AMI, DR and Distribution Management System (DMS) together with MECO’s Supervisory Control and Data Acquisition (SCADA)/ Energy Management System (EMS)
- Insight into specification, procurement, and testing of smart grid systems for MECO and the other Hawaii utilities

The project demonstrated new technologies in South Maui, on two distribution circuits fed by a transformer at MECO’s Wailea substation.

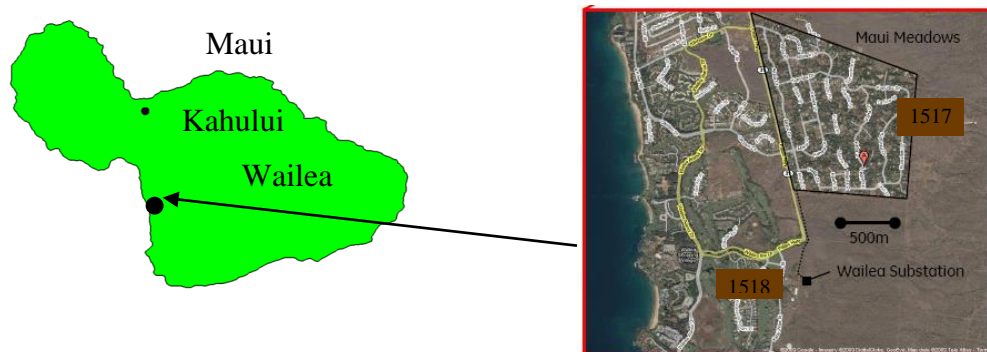

The MSGP implemented:

- Advanced Metering Infrastructure (AMI)
- PV system metering

- DR of water heaters and air conditioner thermostats
- In-Home Display (IHD) of energy use
- BESS of 1 MW with 1 MWh usable storage capacity
- Distribution Management System (DMS) for voltage support and reactive power management

Primary project roles were:

- HNEI: project management, specification of capabilities, data collection and analyses
- MECO: supplied BESS; project implementation, testing, commissioning, operations
- MEDB: continuing consumer outreach and education
- SLIM: workforce training; energy use analysis
- SRA/Sentech: functional specification and system integrator
- SSN: supplied AMI, PV metering, DR, and IHD systems
- Alstom Grid: supplied DMS

The project accomplished its objectives. It was successful in providing MECO with an opportunity to evaluate the capability of several advanced systems and technologies to resolve issues faced by MECO and its customers: high energy costs, the need to manage high penetrations of as-available renewable energy, and constraints on expanding the power system to serve load growth. The customer outreach and education activities proved especially valuable: while the proponents of the “smart grid” often cite the information and choices that smart meters offer the consumer, this demonstration project showed MECO what information customers *really* wanted, and how they wanted it presented. A significant accomplishment of the project was obtaining customer input *before* any system-wide implementation. For example, the project showed that customers would indeed utilize the information provided by smart meters to reduce their energy consumption.

The project spanned a period when the number of new PV installations in Hawaii was doubling every year. From a grid operation perspective, the higher than expected penetration of PV revealed new requirements for monitoring and control of distribution system assets and load flow simulation models. “Lessons learned” in this demonstration have already been applied to subsequent projects: HNEI’s Maui Advanced Solar Initiative (MASI), and HECO’s distribution voltage optimization project.

MECO has already acted on the visibility it gained into the Maui Meadows distribution feeders to adjust tap changer settings and improve voltage support for its customers. Distribution transformers MECO buys in the future will have additional voltage adjustment capabilities that will allow a response to the conditions observed during the project that resulted from high penetrations of PV.

This project afforded MECO its first opportunity to operate a large BESS, giving experience for specifying, installing and commissioning future BESS projects. This is important, as energy storage is proving to be an essential asset for supporting high penetrations of as-available renewable energy sources. The project showed that a BESS is effective for load management, enabling it to smooth variations in loads and renewable energy output. The BESS also demonstrated capability for providing regulation and for shifting times of demand on MECO’s generators. Charging the BESS during nighttime hours uses electricity generated by wind turbines, reducing their curtailment due to excess energy conditions.

The project showed both BESS and DR technologies can be effective in reducing peak loads on the MECO system and of individual substations. The experience gained in this project will help MECO integrate distributed and renewable energy resources (PV, wind) with the operation of its central generators and transmission system. The result will be the ability to support larger amounts of as-available renewable energy resources, improved system stability, higher reliability of supply and lower costs for Maui Electric customers.

The project was funded in part under the American Recovery and Reinvestment Act of 2009. From that perspective, the technology demonstration directly invested in and strengthened Maui's electrical infrastructure. Local workers were educated in energy auditing, equipment installations, and smart grid technologies; this not only gave immediate benefits to a group of jobseekers, but the workforce training developed by UHMC under this project will continue to provide clean energy workforce training on Maui. The experience gained under this project also provided MECO personnel with valuable training on distribution management, advanced metering, BESS management and system integration of renewable energy.

2. PROJECT SCOPE AND OBJECTIVES

The project is under the leadership of the Hawaii Natural Energy Institute (HNEI) of the University of Hawaii. The project team includes Maui Electric Company, Ltd. (MECO), Hawaiian Electric Company, Inc. (HECO), Sentech (a division of SRA International, Inc.), Silver Spring Networks (SSN), Alstom Grid, Maui Economic Development Board (MEDB), University of Hawaii-Maui College (UHMC), and the County of Maui.

The project was designed to develop and demonstrate an integrated monitoring, communications, data base, applications, and decision support solution that aggregates distributed generation (DG), energy storage, and demand response technologies in a distribution system to achieve both distribution and transmission-level benefits. The application of these new technologies and procedures is expected to improve service quality and increase overall reliability of the power system along with reducing costs to both the utility and its customers.

The project had two phases. In Phase 1, energy management architecture for achieving project objectives was developed and validated. In Phase 2, these capabilities were demonstrated at a MECO substation at Wailea on Maui.

2.1 Project Objectives

The project team identified seven primary objectives for applying advanced technologies to the MECO grid in the scope of the project. Distribution-level benefits include:

- D-1: Reduce a distribution system's peak grid energy consumption, thereby demonstrating the ability to relieve transmission system congestion;
- D-2: Improve voltage regulation and power quality within the selected distribution feeders;
- D-3: Demonstrate that the architecture of the demonstration project is compatible with additional distribution management system functions and customer functions likely to be implemented in a legacy system employing "Smart Grid" technology solutions; and
- D-4: Develop and demonstrate solutions to significant increases in distributed solar (photovoltaic systems) technologies being installed at residential and commercial locations.

At the transmission level, the solution will enable coordination of the operation of distributed energy resources (DER) to make the distribution system dispatchable, providing grid services such as:

- T-1: Provision for management of short-timescale intermittency from resources elsewhere in the grid, such as wind energy, solar energy, or load intermittency;
- T-2: Provision for management of spinning reserve or load-following regulation; and
- T-3: Reduction of transmission congestion (through curtailment of peak load).

2.2 Desired Maui-Specific Project Results

Maui, as is true of all of Hawaii, is seeing a tremendous increase in distributed and grid-level renewable energy installations. Operating the grid with high penetrations of as-available renewable energy resources is proving increasingly difficult. There are especially concerns about maintaining the reliability and stability of the grid, maintaining customer voltages within range, and determining the amount of operating reserves needed to support the renewable energy resources. “Smart grid” technologies and functionality have the potential to address these issues, but before a system-wide “rollout” of a smart grid, MECO desires to obtain more familiarity with costs, capabilities, and operating procedures through a pilot demonstration. Determining appropriate functionality for Advanced Metering Infrastructure (AMI) is especially key. So-called “smart meters” offer many capabilities to consumers, but before MECO invests in an AMI system, it wants to determine which of the myriad AMI functions will deliver real value to its customers.

At the beginning of the project, MECO and the rest of the project team identified these key issues or questions to be addressed:

- Improving visibility into the distribution system, including the value of specific information; evaluation of methods to acquire, transmit, process and display the information; resolution (e.g., sampling rate) and latency requirements. Specific research goals included:
 - Data on customer service voltages, resulting in better power quality
 - Understanding the impacts of distributed PV on service voltages
 - Load research – understand how consumption information and PV system installations impact residential energy use.
- Determining the amount of photovoltaic (PV) energy supplied by distributed generation on the system
- Use of Demand Response (DR) to reduce peak load and mitigate variations of as-available renewable energy resources
- Experience with specification, installation, and operation of Battery Energy Storage System (BESS), including smoothing variability from renewable energy and loads
- Identifying “Smart Grid” functions, especially “smart meter” functionality, of most value to MECO customers (in preparation for system-wide smart meter rollout)
- Improved volt/var management
- Determine MECO training and staffing requirements for smart grid implementation and operation (meter shop, installers, system operators, etc.)
- Integration of AMI, DR, Distribution Management System (DMS), Supervisory Control and Data Acquisition (SCADA)/ Energy Management System (EMS)
- Insight into specification, procurement and testing of smart grid systems for MECO and the other Hawaii utilities. This includes selecting the functionality appropriate for MECO service territory

2.3 Project Location

The project demonstrated new technologies in the Wailea area of South Maui. The installations occurred at locations served by two distribution circuits fed by a transformer at MECO's Wailea substation. Figure 2-1 illustrates the project location in greater detail.

The two distribution circuits (1517 and 1518) serve two different portions of the South Maui service territory. Circuit 1517 runs north from the Wailea substation and serves the Maui Meadows neighborhood. This is a relatively large residential subdivision (about 1,000 homes) consisting primarily of single family homes with a variety of housing styles, ages and energy efficiencies. Maui Meadows is the target neighborhood for demonstrating the residential AMI, DR, and PV monitoring aspects of the project.

Circuit 1518 primarily serves commercial customers in the resort areas of Wailea and Makena. These customers include most of the major resorts in this area, retail development, and condominiums associated with the resorts.

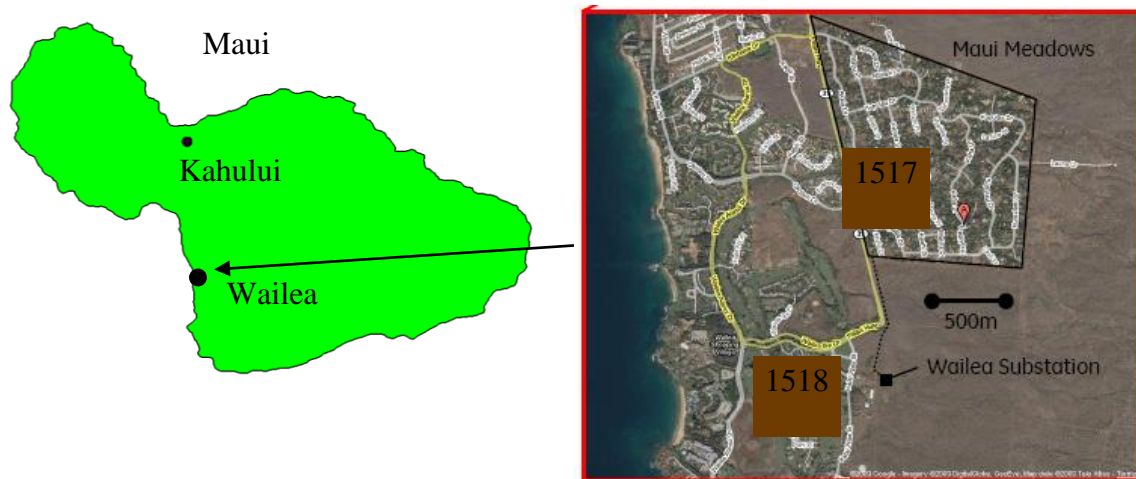

Figure 2-1: Overview of Maui and Project Location

Recently, Hawaii has seen the number of distributed (residential) PV installations almost doubling every year, and Maui Meadows is no exception. By the end of the project's test period, there were 168 PV installations in Maui Meadows (16% of the homes), far higher than had been anticipated (see Figure 2-2). As a result, system designs and operating strategies had to adapt during the project to meet this larger than expected penetration of PV. Experience from this project has already been applied to the design and architecture of a second smart grid/smart inverter project (Development and Demonstration of Smart Grid inverters for High-Penetration PV Applications, U.S. Department of Energy (DOE) award DE-EE0005338, also known as the Maui Advanced Solar Initiative – MASI).

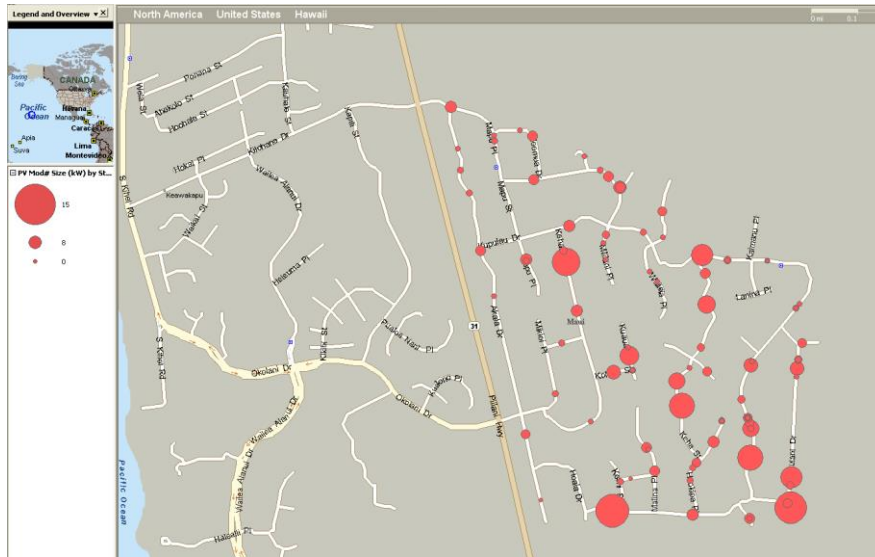

Figure 2-2: Solar PV inverter locations in Maui Meadows

A 1 MW / 1.23 MWh BESS was installed on circuit 1517 close to the Wailea substation transformer serving circuits 1517 and 1518.

2.4 Primary Functions Implemented

Advanced Metering Infrastructure (AMI)

“Smart” meters reported household energy use in 15 minute increments and voltage at the service entrance. Customers had access to their house-specific web page where they could view their energy consumption. (For houses with PV panels, this meter showed their net energy consumption from the MECO grid.)

Photovoltaic (PV) Metering

Homes with PV panels had a separate meter installed to measure electrical output of the PV panel in 15 minute increments. As with the household energy use, these customers had access to their house-specific web page where they can view their PV energy production.

Demand Response (DR)

Electric water heaters (WH) could be turned off by a DR command. Central air conditioners (A/C) can be equipped with an adjustable thermostat that could raise the setpoint a specified amount upon receiving a DR command.

In-Home Display (IHD)

Customers could request an in-home display that showed current energy price, energy use and energy cost for the house and for selected appliances, and also display messages from the utility (e.g., notifying customer of a demand response event).

Battery Energy Storage System (BESS)

A 1 MW / 1.23 MWh battery was installed on feeder 1517 close to the Wailea substation. However, due to operating restrictions, the effective capacity of the BESS is limited to 1 MWh.

Charge and discharge can be by schedule or MECO command. MECO can also adjust the power factor (i.e., reactive power component) of the battery's output.

Distribution Management System (DMS)

- Distribution load flow and volt/var control. The DMS included a validated feeder load flow model that could be used in “study mode” to predict the results of changes to transformer tap setting, capacitor operations, changes in load, etc. While the Alstom DMS includes the capability for automated volt/var control, for this project the DMS was used only in “study mode” to evaluate options. All controls were initiated by MECO operators.
- Distribution voltage/current monitoring. Several voltage and current monitors were installed on Feeders 1517 and 1518. Their data were input to the SCADA system through the SCADA Remote Terminal Unit (RTU) in the Wailea substation.

Appendix 2 lists the primary equipment, communications, software and services implemented during the project.

3. SYSTEM SPECIFICATION / DESIGN

The design of the Maui Smart Grid was an iterative process that divided into three main components:

- SSN Data Center (AMI Headend)
- AMI and Communication System
- DMS

The design of each system consisted of several steps, including defining the requirements, equipment selection, factory acceptance test, and system acceptance testing. During each stage of this process; requirements were modified and capabilities defined. Figure 3-1 presents the overall architecture of the system. Each system architecture component will be described in more detail in the following sections.

3.1 AMI and Communication Architecture

The project team designed the specific AMI and communications architecture needed for integration with the DMS and developed the functionality with selected meter and communication platforms. To assure compatibility with the utility's operations and communication protocols, security, and compatibility with existing/planned equipment and software upgrades, this design and architecture was developed under the advisement and review of HECO's AMI team. Any third party support needed to execute the design and implementation, especially of the following features, was identified and discussed with the National Energy Technology Laboratory (NETL) project management:

- SSN meter integration with Home Area Network (HAN) Devices (Programmable Thermostats, Load Control Switches, IHDs);
- MECO's legacy backbone communication infrastructure integration with DMS and other back office applications;
- DMS Integration with SSN AMI Headend and Demand Response Management System (DRMS);
- Integration / interface of MECO SCADA system with DMS system; and
- Integration of feeder current sensor data into existing Wailea substation (RTU).

3.1.1 Silver Spring Networks (SSN) Data Center (AMI Headend)

The SSN Data Center is the Maui Smart Grid Project's (MSGP) AMI headend and is located within an SSN data center in California (with backup center located in Nevada). The AMI headend is deployed in a Software-as-a-Service (SaaS) environment, including the software license, maintenance, hardware and hosting.. Communication between the AMI head-end and the MECO Operations Center was through a secure Virtual Private Network (VPN) connection over the Internet.

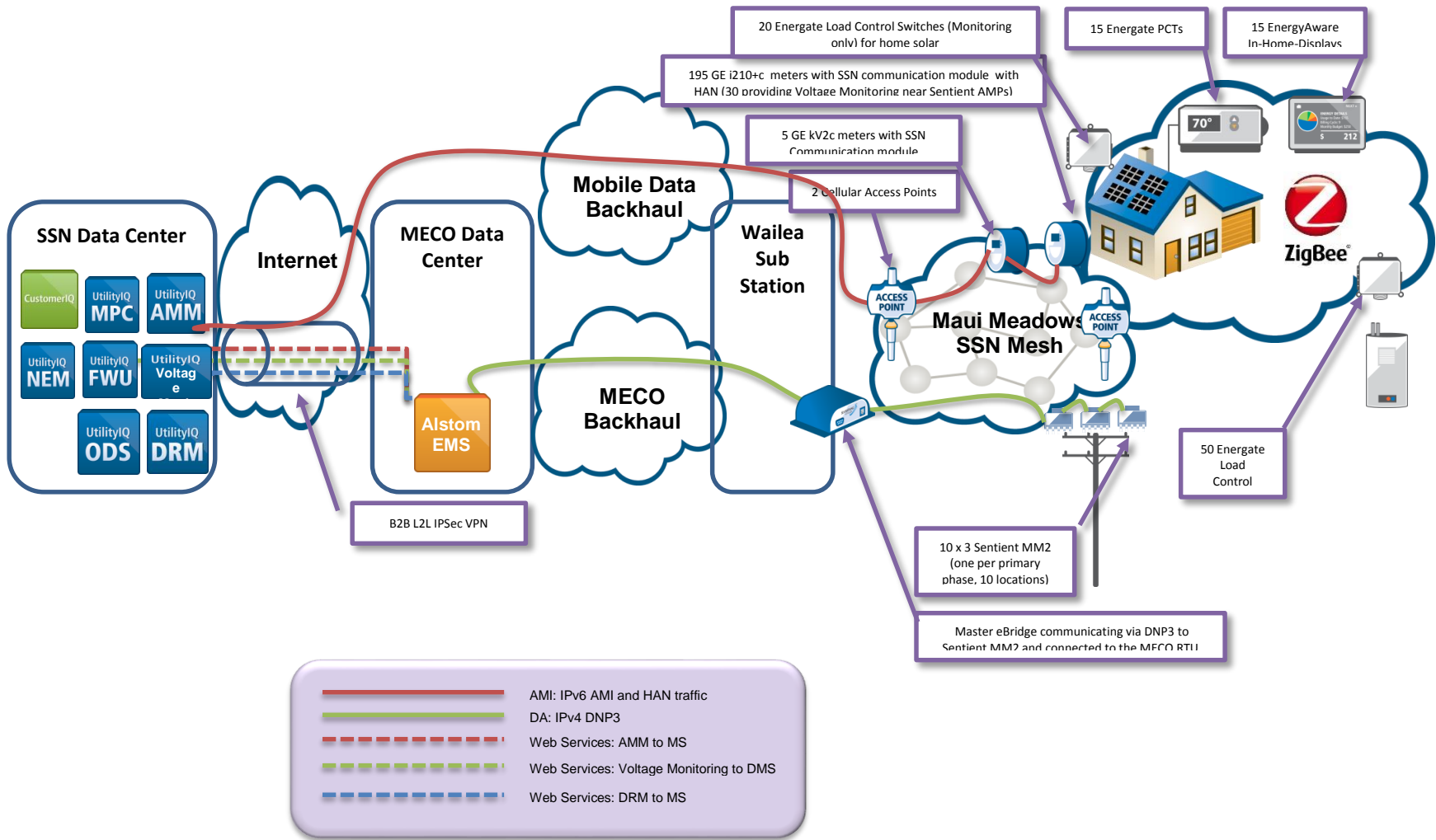

Figure 3-1: MECO Smart Grid Functional Depiction

3.1.2 AMI System

The AMI portion of the MSGP consists of two major components: the smart meter and the AMI communications infrastructure.

3.1.2.1 AMI Communication Infrastructure

The AMI infrastructure provided the communications platform between the Wailea substation and the consumer. The infrastructure consisted of an IPv6 based 900 MHz frequency hopping spread spectrum (FHSS) meshed network. The network was developed through the use of two types of radios: access points and relays.

The Access Point (AP) provided the central link between endpoint devices and network control and monitoring. The Access Point is a router that was mounted on power poles or street lamps. All outbound communications (requests for data) from the Demand Response Management System (DRMS) pass through the AP; all inbound data packets (data, alarms) pass through the AP. The AP could also pass information through multiple relays, or through SSN-enabled electricity meters, and it offered multiple paths to each endpoint through sophisticated mesh network routing that ensures greater reliability and redundancy. All APs contained battery backup for operation if the primary power source was lost.

The relay allowed the utility to extend network reach to more customers. The relay supports a long list of value-added applications and services, including advanced metering, outage/restoration management and distribution automation (DA).

Figure 3-2 shows the locations for each relay; Figure 3-3 shows the location of each AP.

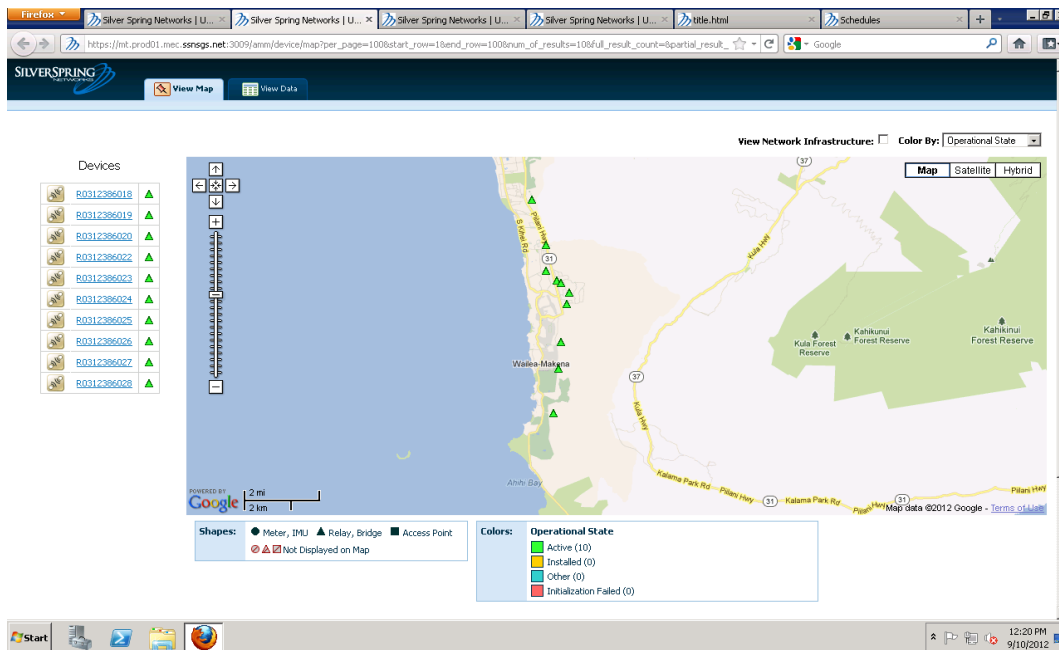

Figure 3-2: Maui Smart Grid Relay Locations

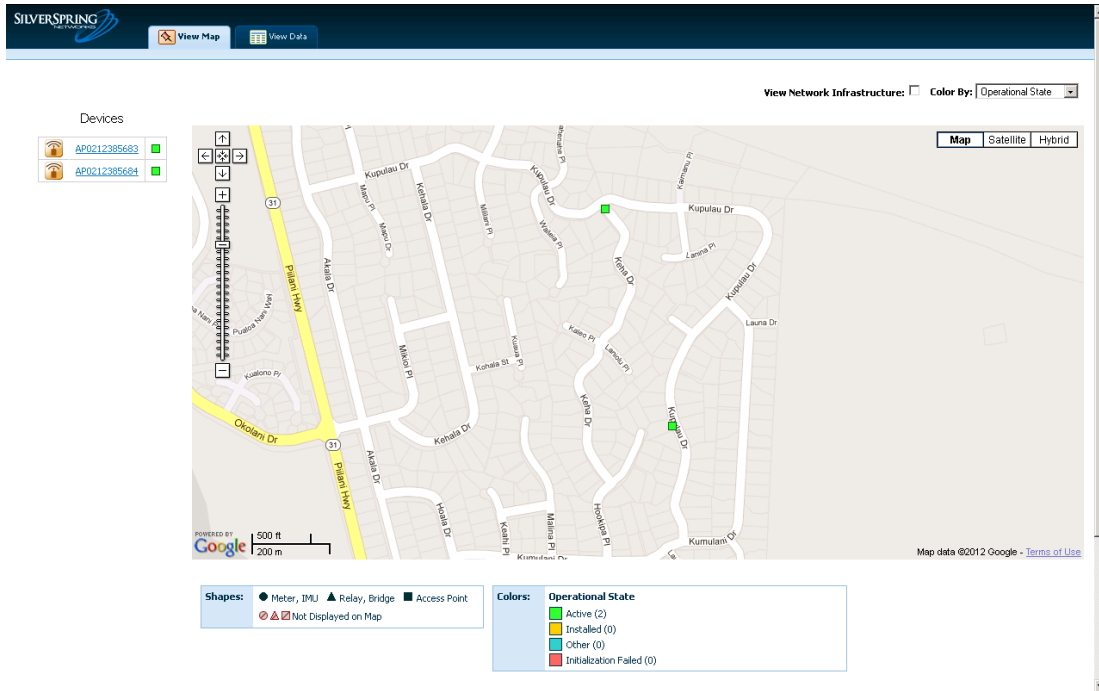

Figure 3-3: Maui Smart Grid Access Point Locations

3.1.2.2 Smart Meter

The smart meter is connected to the customer and is used to:

- Collect whole-house usage
- Collect PV-generation information
- Communicate demand response messages and commands

The smart meter used for this project is the GE I-210+C meter with an SSN network interface card (NIC) installed under the meter glass. The SSN NIC card acted as the communication gateway for all information between the utility and the consumer. The NIC Card has the following basic characteristics:

- The module communicates with meters via a serial connection and can query all meter registers.
- Home Area Network (HAN) product offering involves stacking the ZigBee Pro and ZigBee Smart Energy Profile on top of the 2.4 GHz 802.15.4 radio.
- AMI communication Interface: radio operates on unlicensed 902-928 MHz band using FHSS technology over IPv6.
- All meter data will be collected through the AMI Headend. DR and PV information will pass through the AMI Headend for use by the DRMS and DMS system.

3.1.2.3 AMI Data Flow

The following figure presents the AMI data flow. Other applications such as DR, PV monitoring, and parts of the distribution automation information will be through the AMI system. These data flows are presented in those specific sections. This data flow diagram focuses on the meter reads. MECO monitored and communicated with the smart meters through the SSN AMI interface.

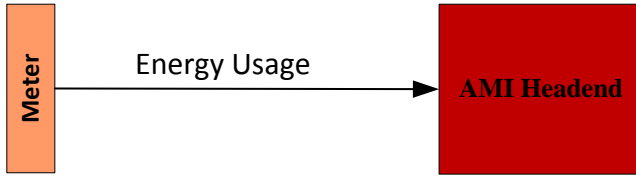

Figure 3-4: AMI Meter Reading Data Flow

3.1.2.4 Demand Response

The demand response was controlled through the DRMS offered as a SaaS from SSN. All communication to devices within the home us Zigbee communication to/from the smart meter. Figure 3-5 outlines the various demand response configurations for the project.

	Demand Response Options	Equipment Installed	Controllable Loads
1	Basic	1. GE I-210-C meter with an SSN network interface card (NIC) 2. EnergyAware Power Tab In Home Display	None
2a	Demand Response – Programmable Thermostat	1. GE I-210-C meter with an SSN network interface card (NIC) 2. EnergyAware Power Tab In Home Display 3. Energate Z100 Programmable Communicating thermostats	A/C setpoint
2b	Demand Response – Water Heater	1. GE I-210-C meter with an SSN network interface card (NIC) 2. EnergyAware Power Tab In Home Display 3. Energate LC301 Load Control Switch	Hot water heater (WH)
3	Commercial	GE KV2 Meter	None

Figure 3-5: Demand Response Options

3.1.2.5 Consumer Devices and Home Area Network (HAN)

DR solution consists of Direct Load Control and Indirect Load Control mechanisms. Direct Load Control involves issuing a direct command that results in the reduction or shift in power consumption. Indirect Load Control involves sending messages to incentivize the reduction or shift of power consumption. DRMS will initially use ZigBee Smart Energy Profile (SEP) 1.0. The in-home equipment includes the following:

3.1.2.5.1 Load Control Switches

The MSGP deployed the Energate LC301 Load Control Switch (LCS) for all 120V applications.

3.1.2.5.2 Programmable Thermostats

The MSGP deployed the Energate Z100 programmable communicating thermostats (PCT). The PCTs enabled signals and control of forced air systems. PCTs will also receive and display messages sent by the DRMS.

3.1.2.5.3 In-Home Displays

The MSGP deployed EnergyAware Power IHD. The IHDs enabled whole home energy usage information to be retrieved from the ZigBee meters and displayed in the home. IHDs also received and display messages sent by the DRMS.

3.1.3 Demand Response Management System (DRMS)

The DRMS head-end, located within the SSN data center, is deployed in a SaaS environment including the software license, maintenance, hardware, and hosting. Data from the field devices traversed the SSN AMI network to the Wailea substation and communicated to the DRMS through a VPN Internet connection. The initial design required the DRMS to communicate with the DMS, located at the MECO Operations Center over a VPN Internet connection. Due to the time required to implement this capability, in the final design, the DRMS did not interface with the DMS. MECO staff initiated DR events through the SSN DRMS interface.

3.1.3.1 Demand Response Data Flow

Figure 3-6 presents the data flow for the DR options presented in Figure 3-5.

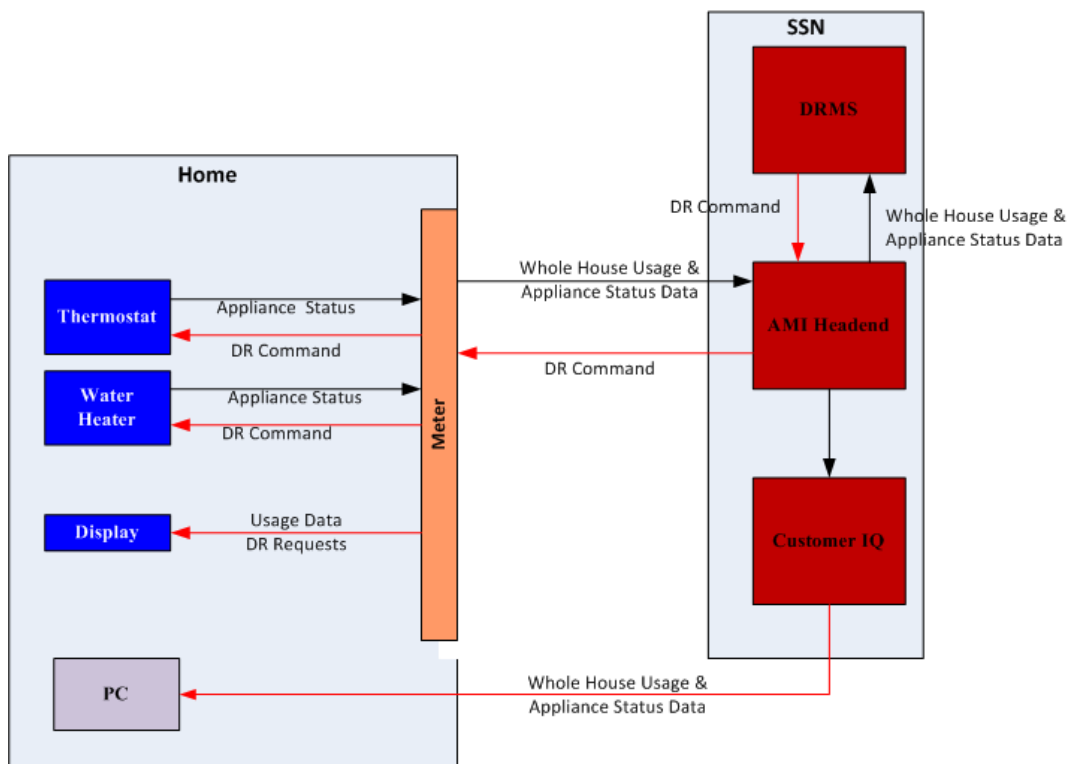

Figure 3-6: Demand Response Data Flow

3.1.4 PV Monitoring

Residential PV systems and inverters—if the communication module was installed—was designed to provide the homeowner with PV information either on an IHD or through a web-based service, through the homeowner’s Internet connection, offered by the inverter

manufacturer. These inverters are not designed to communicate information to the utility through the HAN. For the MSGP, monitoring of the residential inverters was accomplished through the installation of a second smart meter to monitor and communicate PV generation data to MECO through the SSN AMI Headend. The data flow is identical to that of the AMI data.

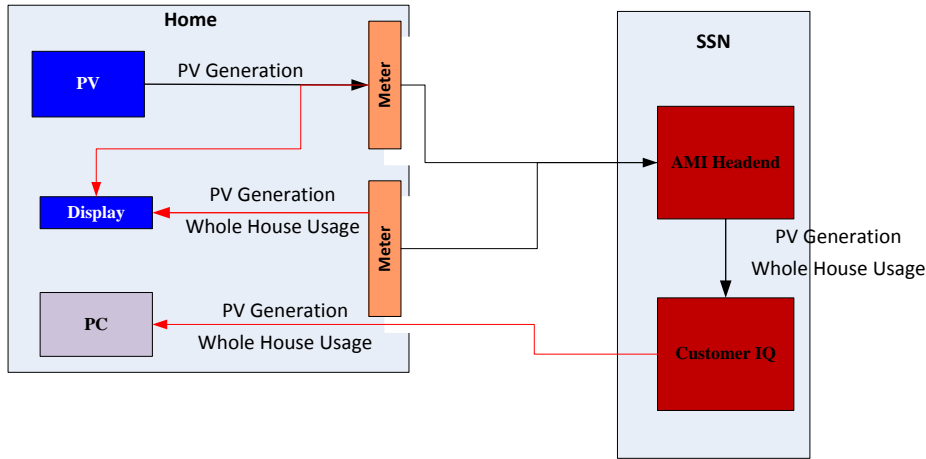

Figure 3-7: PV Monitoring Data Flow

3.1.5 Distribution Automation

The distribution automation component of the project will be deployed on feeders 1517 and 1518, as shown in Figure 3-8, using several technologies.

3.1.5.1 Distribution Feeder Line Current

In general, feeder current was captured using the Sentient MM2 series line monitors. The original design for line current and voltage monitoring involved the addition of pole-mounted current transformers and power transformers. This solution proved unworkable as it placed too much additional loading on the distribution poles, and the interface to the communication system required installing multiple communication components requiring power (equipment was not line powered). Alternative solutions were evaluated, with the Sentient MM2 line monitors being selected because these overcame the challenges presented by the initial solution. These monitors were line mounted (not pole mounted) and have a built-in SSN Network Interface card (NIC) card that communicate with the SSN neighborhood network through the eBridge to the Wailea substation. At the Wailea substation, the information was integrated through the existing Orion RTU for communication over the existing SCADA communication system. The DMS system collected the distribution line current data through the DMS interface with the SCADA system. Figure 3-9 lists the locations of the current sensors.

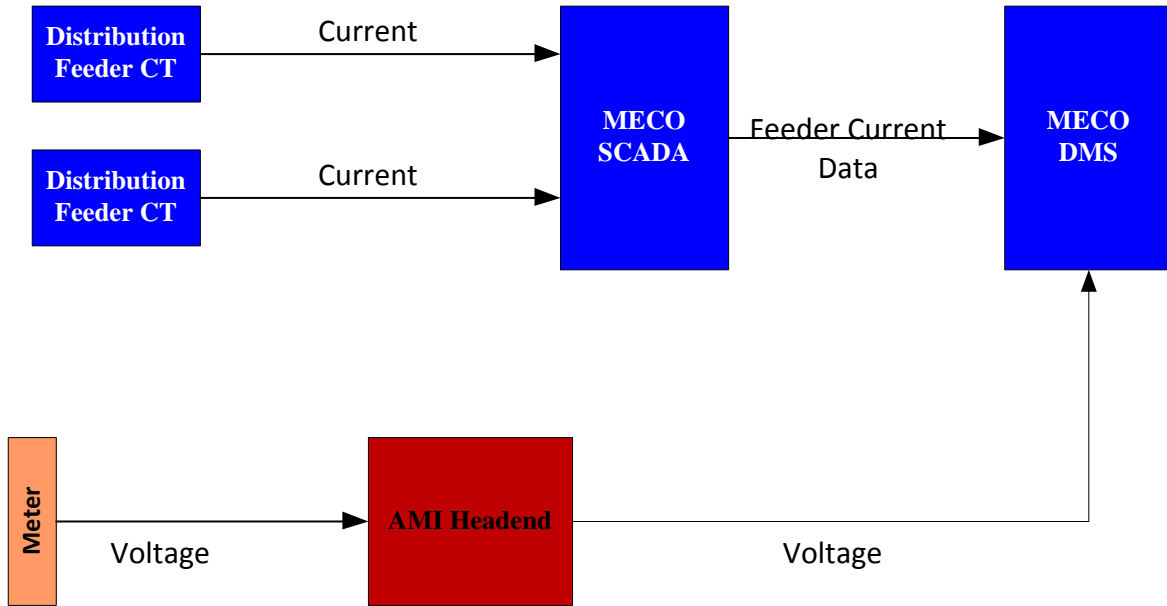

Figure 3-8: Distribution Automation Data Flow

Current Monitoring Device Locations	
1518 Riser at Wailea Sub	Mapu PL E2
1518 Riser at Wailea Sub	Mapu PL E2
1518 Riser at Wailea Sub	Mapu PL E2
Kupulau Dr E4	Mikioi ST E1
Kupulau Dr E4	Mikioi ST E1
Kupulau Dr E4	Mikioi ST E1
Makena Alanui E31A	OVHD to Makena E24
Makena Alanui E31A	OVHD to Makena E24
Makena Alanui E31A	OVHD to Makena E24
Makena Alanui E4 (E1-side)	Pilani Highway E145
Makena Alanui E4 (E1-side)	Pilani Highway E145
Makena Alanui E4 (E1-side)	Pilani Highway E145

Figure 3-9: Locations of Feeder Current Sensors

3.1.5.2 Distribution Feeder Voltage

Voltage levels were determined based on voltage readings from specific smart meters and communicated through the AMI system. Alarm conditions were reported as exceptions through the AMI system to the DMS.

3.2 MECO Operations Center

3.2.1 Distribution Management Center

The DMS system was installed at the MECO Operations Center. Communication from the AMI Headend and the DRMS was through a VPN Internet connection. The DMS collected distribution feeder current measurements through the existing MECO SCADA system and distribution feeder voltages through the AMI system. All command and message requests were sent through the VPN connection to the AMI Headend for communication to the specific devices and locations.

3.2.2 Interface to DRMS and AMI

The interface between the MECO Operations Center DMS AMI Headend was through an Internet VPN connection using IPv6 and IPsec.

3.3 Cyber Security Architecture

Cyber security and the protection of Personally Identifiable Information (PII) was a component of the project from the initial requirements definition, through equipment selection and the design, implementation, testing, and operation of the system. Throughout each phase of the project both MECO and HECO cyber security staff were involved in reviews of the design and cyber security measures. The following steps were completed as part of the cyber security review and approval process:

- The Project Team used industry standard cyber security methodologies, tools, and protocols to select equipment and design the system.
- The Project Team submitted architecture, equipment lists / specifications, and cyber security plan to MECO and HECO Cyber Security teams.
- HECO and MECO Team reviewed the Cyber Security Plan and approved the plan
- SSN submitted the SSN Headend cyber security plan and architecture for approval by the MECO and HECO Cyber Security teams for management and access to data maintained at the SSN data center(s).
- MECO and HECO Cyber Security teams approved the project team cyber plans.

The following sections provide an overview of the architecture and specific standards implemented as part of the MSGP.

3.3.1 Defense in Depth Security Approach

The cyber security approach for the implementation of the MSGP used the defense in depth methodology accompanied with the design of the cyber security components, features, and capabilities from the beginning of the project. Cyber security was not an “add-on” to the project but a critical component from the initial concept through implementation.

The defense in depth approach focused on people, technology and operations. From a technological perspective, the security solution encompassed measures at all levels of the Maui

Smart Grid from the breaker or generator to the DMS. For example, field devices were equipped with intrusion detection/tamper detection technologies as well as accepted encryption technologies for the transfer of information. During initialization of the equipment, each device was required to go through an authorization process with the network control system. This authorization process ensured that the device was allowed to participate on the network. This authentication process was reinitiated prior to any communication system and/or network interface software or firmware upgrade. Once the data reached the DMS, access to the system and functions was limited through the appropriate access control methods. The final layer of the defense in depth approach was that the system was a closed system. A limited number of access points were established through the existing MECO information technology (IT) infrastructure to allow access by MECO staff / management during the project. Firewalls were installed at these access points to limit the traffic through the gateway to and from the DMS.

The final cyber security approach was the deployment of a private network to support the smart grid functions. The network implemented was a private IP network only used for smart-grid and no other non-MECO applications. There were only a few external connections from this “private network” including the interface between the existing MECO SCADA system and the DMS (both located in the MECO Operations Center) and external interface to the MECO business LAN for access of information by other authorized MECO personnel. Customer access to energy usage data was through the IHD, which pulls data from the home’s meter, or through their own Internet connection to the SSN customer system.

3.3.2 Cyber Standards

- **PCI Version 3.0** (Back Office) — Compliant then Certification
- **ISO 27001/02**(Back Office) — Certification ‘mapping against standards’
- **NIST 800-53** (Back Office) — Recommended Security Controls for Federal Information Systems and Organizations
- **NERC-CIP**(Smart Grid) — Only Relevant/Subset Standards
- **NIST-7628** (Smart Grid) — Emerging Smart Grid Standards
- **FIPS 140-2** Certification (Relevant Components of the Smart Grid and/or Back Office)

3.3.3 Data Security at SSN Facilities

SSN was responsible for maintaining and protecting the AMI data and all data related to the demand response programs. Because these data were being housed by a third party, the question of data security and data privacy became an additional issue. SSN provides this service to several customers and implemented a robust security architecture to ensure that data and privacy are protected. The back-office cyber security features include:

- **Encryption Protection Layer:** VPN IPSec, SSL, SSH, SFTP
- **Perimeter Security:** Firewall, vulnerability assessment
- **Infrastructure Layer Security:** SSL VPN, 2 Factor Auth., NIDs
- **Compartment Security:** Customer data secured in independently protected sections
- **Security Services:** Deliver control, audit and regulatory assurance efficiently on a per customer basis

3.3.4 Cross Domain Security

Cross domain security issues exist where one network needs to exchange information with another. In the Maui Smart Grid, this cross domain exchange existed in four places based on the project definition of segregating the MSGP from MECO operations. The cross domain areas and security measures are defined below.

1. **Feeder Current Transformer to MECO RTU at Wailea Substation** – Data were transferred from the SSN E-Bridge Master located at the Wailea substation (provides communication of data from the feeder current transformer) to the MECO RTU within the Wailea substation. The communication used DNP3 communication protocols to interface with the MECO system. The feeder current data was communicated to the MECO SCADA system and the DMS over the existing MECO SCADA communication system.
2. **MECO SCADA System interconnection with DMS** – There was an ISD protocol connection link between the MECO SCADA system and the DMS that allowed the transfer of MECO SCADA data into the DMS system.
3. **DMS and SSN Hosted Services** – The DMS was firewalled from both the VPN Internet connection at MECO and at SSN using IPSec standards.
4. **DMS / MECO SCADA and MECO IT** – The MECO IT system was treated as an external user. A connection was established through the firewall to allow access for viewing information by authorized personnel through a data diode allowing only a one way transfer of data.

3.4 Distribution Management System

The Alstom **e-terra***distribution* was selected as the DMS for the Maui Smart Grid Project and was installed at the MECO Operations Center. The DMS system acts as the master controller and decision support system for all of the monitored and manageable assets on the distribution grid. As the overarching system, the DMS system communicated with other function-specific systems and did not communicate directly with individual devices. Because the DMS system was used as part of a demonstration project, all information and decision options were presented to a MECO operator for final approval and initiation of control (no closed loop control by the DMS). This ensured that, during the development, none of the DMS decisions adversely impacted the customers or the MECO system.

This section provides an overview of the DMS architecture and the functional interfaces necessary for the DMS to assist the MECO operator to make informed decisions.

3.4.1 DMS Change during Budget Period 2

The DMS system originally planned for the MSGP was the General Electric GENE system. Although GENE was a commercial product, and deployed in power systems in North America, many of the features and functions necessary to support the Maui Smart Grid still had to be developed as the existing functionality did not meet the project requirements. Extensive project team meetings determined that the development schedule for adapting the GENE system to meet the functional specifications did not match the project schedule. Several potential DMS solutions were evaluated. MECO determined that modifications of ALSTOM's **e-terra***distribution*

entailed the least technical and performance risk, and because MECO's existing EMS / SCADA system is an Areva/ALSTOM, a pilot installation of the ALSTOM DMS would provide the best path to expand the functionality to the entire MECO system.

3.4.2 DMS System Description

The Alstom **e-terradistribution** is a commercially available system that was enhanced to support the requirements of the Maui Smart Grid. The following sections provide a description of the DMS and the associated components. Many of these applications can be operated in either study mode or operational mode (sometimes both at the same time).

3.4.3 DMS Architecture

Figures 3-10 and 3-11 present the Alstom System architecture and components.

For the MSGP, the following modules of **e-terradistribution** were deployed. Additional modules could be implemented at a later stage for an transition towards a full deployment of an integrated DMS if MECO expands the project to a full Maui smart grid implementation:

- Distribution SCADA
- Network View
- Network Analysis
- Network Optimizer
- Switching Operations

Figure 3-11 presents the Alstom DMS modules.

3.4.4 DMS Component Description

Distribution SCADA - The SCADA module gathers real-time data from remote terminal units and other communication sources in the field, and it enables the control of field devices from consoles. **e-terrascada** is a distributed, scalable system implemented in an **e-terrahabitat** real-time control system environment. Communication between the **e-terrascada** server and the **e-terradistribution** server is through an Intersite Data (ISD protocol) link

Network View - Network View module consists of the Network Operations Model combined with a powerful Network Operations user interface (UI). Network View provides a high-level of functionality while also serving as the foundation for more advanced applications. The Network Operations UI enables the user to maintain a high level of situational awareness through its geographic and schematic views, while also enabling efficient access to distribution data and controls. The UI enables the operator to apply aggregate controls at the system, substation, and feeder levels. Drill-down capabilities provide rapid access to data and controls for individual devices, such as is also available through SCADA. Network View supports full real-time operations by maintaining both static and dynamic data, and presents this information to the operator in a single consistent view of the network.

**Maui Electric Company
Distribution Automation Architecture (Functional View)
EMS / DMS Integration**

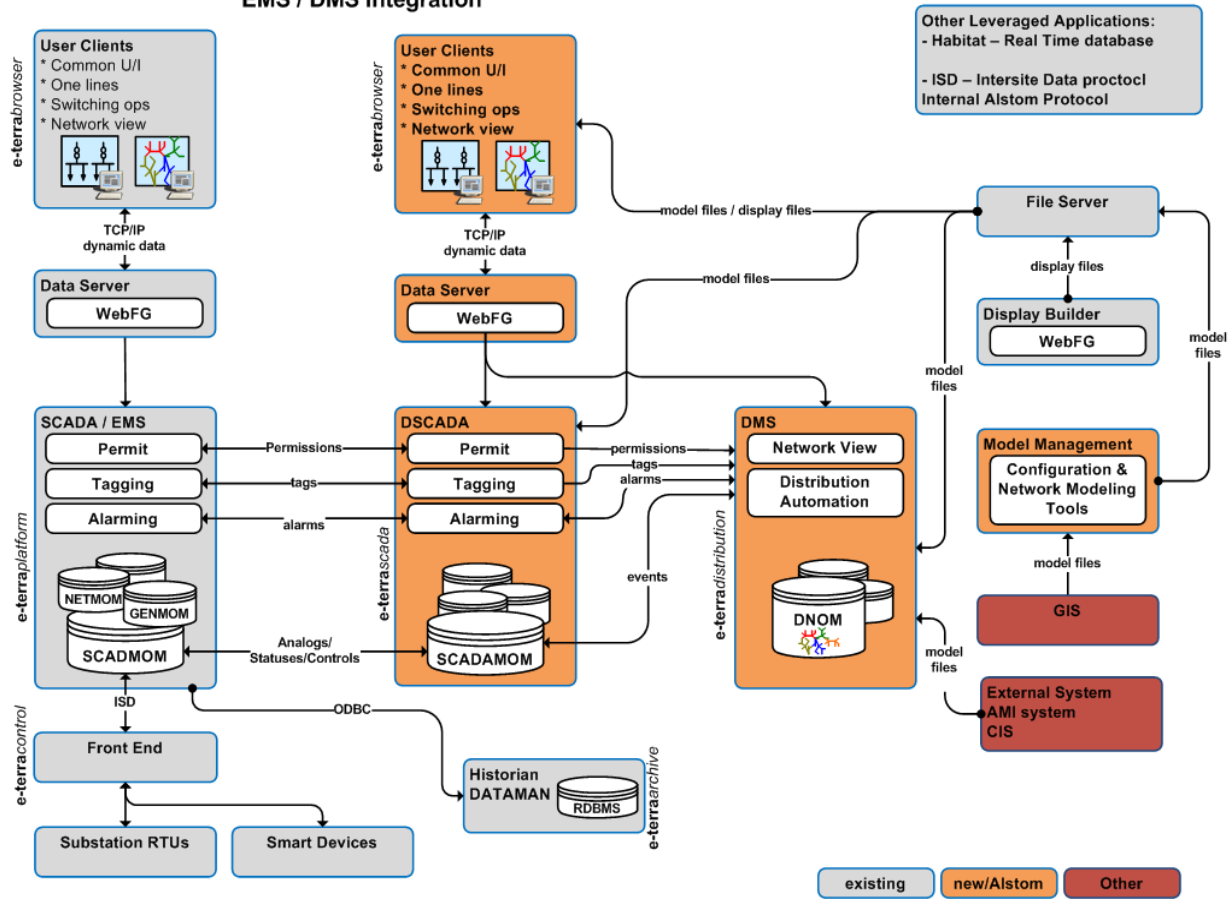

Figure 3-10: DMS System Architecture

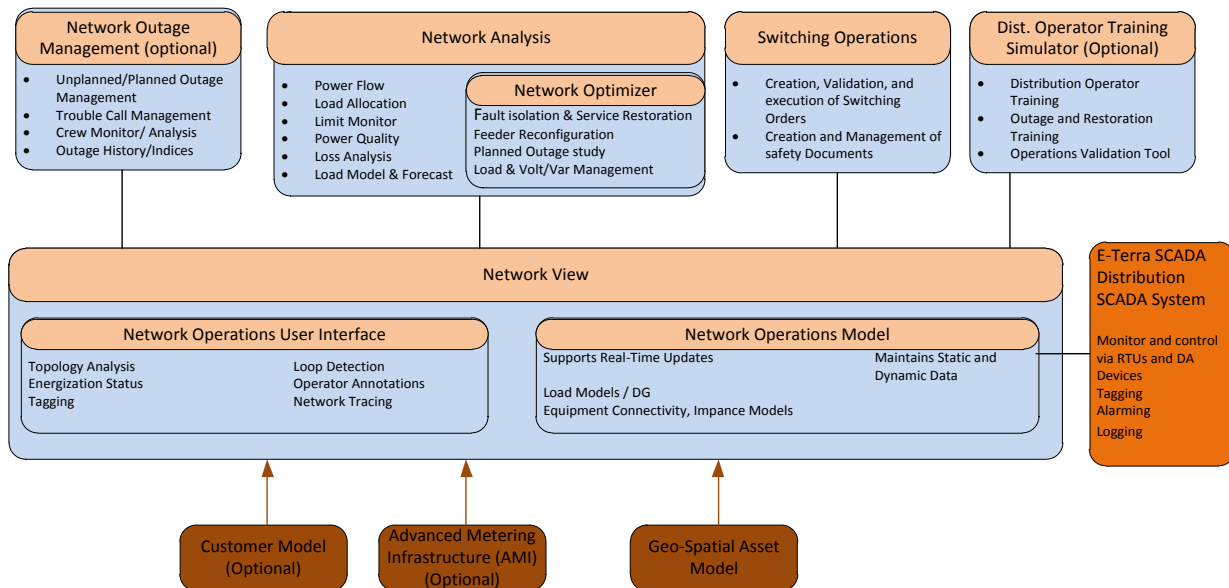

Figure 3-11: Alstom System Modules

Network Analysis - Network Analysis is a key part of the suite of applications for real-time network management. It provides a full, unbalanced, real-time power flow for the entire network. Study copies of the current real-time network can be created instantly and modified to analyze planned or alternate conditions.

Network Optimizer - The Network Optimizer is part of the suite of applications for real-time distribution network management. It allows the operator to optimize the network configuration, improve feeder voltage profiles, and automatically perform restoration switching, an essential component of any Smart Grid implementation.

Switching Operations - The Switching Operations application is part of the suite of applications for real-time distribution network management. It integrates fast and accurate switching procedures into the network management environment and is a key module that expands the operations of the Network View to support the formal process of switching on the network. It interfaces directly to the Network Operations Model and the network display.

3.4.5 Integration with the MECO SCADA System

The DMS shares technology and tools with MECO's SCADA/EMS system, so that adoption of Alstom's DMS solution provided MECO a significant advantage in supporting and developing staff capable of capturing the full value of Alstom's systems. In particular, the following systems, tools and processes are the same for DMS and EMS systems:

- **e-terra***scada* is used as the SCADA platform for both EMS and DMS. MECO, as an initial plan, installed a new instance of the same SCADA solution to provide exclusive support of the DMS.
- **e-terra***control* is used as the Front-End platform for both EMS and DMS. As with SCADA, MECO will use its existing Front-End to support the DMS. Alstom's **e-terra***control* product integrates RTU communications from the substation and also supports integration with intelligent devices.
- Tagging is a shared function between DMS and MECO's EMS through the deployment. This allows close coordination of maintenance, repairs, and modifications on both the distribution and transmission grids. This contributes to improved efficiency in the execution of field efforts and, more importantly, reduces risk of safety violations.
- Alarming and permissions are also shared functions between DMS and MECO's EMS. **e-terra***scada* provides alarm and permit functions to support both DMS and EMS. The UIs and control for acknowledging, clearing and deleting alarms is through SCADA windows presented in the DMS and EMS environments.
- **e-terra***archive* is the shared relational database (RDB) historian used by both DMS and EMS to support archiving of SCADA data. The existing historian was used for this pilot project.

The DMS provided scalable outage-management and distribution-management capabilities, and technologies to support integration of intelligent devices and advanced controls. These include:

- Three-phase unbalanced power flow for radial, meshed, and islanded configurations.

- Predictable outage restoration using network analysis capabilities. Automated self-healing network management and tools that help operators manually restore the system and maintain the system before outages strike.
- Network modeling was maintained through a real-time, dynamically adaptive approach.
- Closed-loop (not implemented) and manual control of substation reconfiguration and switching operations.
- Ability to perform anticipatory/proactive reconfiguration to head-off emerging problems.
- Ability to reconfigure control center operations dynamically in response to changing needs (i.e., from anticipated weather and activity levels as well as unanticipated outages and emergency conditions).

3.4.6 DMS Interfaces

The DMS system required data from various systems and resources supporting the MECO system and the demonstration project. These include but are not limited to:

- MECO SCADA system
- AMI Headend
- DRMS
- BESS
- Residential PV

3.4.6.1 MECO SCADA System

The Alstom DMS and MECO SCADA system were connected through an ISD connection that allowed data to pass from the MECO SCADA system to the ALSTOM DMS.

Among the input data used by the load flow were the voltage magnitude and relative phase angle at the injection. The phase angle was not critical given that both feeders are connected to the same substation transformer. This information was calculated by the Transmission System State Estimator and exported to the DMS. However, since the existing MECO Transmission System State Estimator did not converge reliably, SCADA voltage magnitude measurements were used instead, and the phase angle was set to zero.

3.4.6.2 AMI Headend

The AMI function was part of the larger SSN Utility IQ suite of software and automated the process of collecting meter data. The SSN AMI system communicated the following information to the DMS system:

- Aggregate load on the low side of each distribution transformer.
- For feeder 1517, AMI voltages were collected through customer meter locations closest to the selected monitoring points. These points included locations along the feeder and end-of-line.
- For feeder 1518, one AMI voltage value is reported per phase per selected pole-mounted distribution transformer. These meters were mounted with the distribution transformer at selected locations including end-of-line.

- ALSTOM Load Flow component used the voltage data collected from the meters on both feeders 1517 and 1518.
- Sent an alarm if other meter voltages off the distribution transformer are outside our tariff: +/- 5%.
- The ALSTOM DMS polled all the meters downstream from a specified distribution transformer through the AMI system interface.
- The AMI end of line voltages reported by AMI Headend served as inputs to the Alstom Distribution Load Flow.
- The Distribution Load Flow used the AMI meter voltages to calibrate the distribution load flow model and to adjust the model's coefficients.

3.4.6.3 Demand Response Management System

The DRMS provided the HAN device control, DR program management, and analytics needed to implement both condition-based and direct load control DR programs. The software worked with both Advanced Metering Manager and the Silver Spring CustomerIQ energy web portal to help utilities cut energy use during peak load times or modify loads to achieve better feeder voltage profiles. DR was also tested to mitigate short-term variability in renewable energy outputs (e.g., scram function in response to sudden drop in wind farm output).

3.4.6.4 Battery Energy Storage System (BESS)

Communication with the BESS was via an RTU. Alstom communicated with the BESS via the EMS SCADA.

Inputs from the BESS will included:

- State of Charge (SOC) - available stored energy (how many kW for how long).
- Indication whether BESS is charging, fully charged, or discharging.
- Rate of charge or discharge, expressed in Amps.
- When charging, the BESS will act as a load, and its power consumption will be taken into account by the Load Flow. Conversely, when discharging, the BESS will act as a generator and its power generation will be taken into account by the Load Flow. The BESS will be controllable directly by the operator via the dashboard, but will not be directly controlled by the ALSTOM DMS.
- The operator can also use the BESS information in a study mode on the DMS to determine the potential impacts of implementing a BESS action prior to actual execution.

BESS accepted watts, var, voltage, and power factor set points. BESS was modeled in ALSTOM DMS as a combination of a generator (when injecting power) and a load (when storing power) connected to the substation bus.

3.4.6.5 Residential PV

Residential PV was monitored through the addition of a second smart meter on the house that monitors just the PV inverter(s).

4. IMPLEMENTATION SCHEDULE

Figure 4-1 presents the schedule of the primary project tasks and milestones for the HNEI Maui Smart Grid Project.

WBS	Name	Start Date	Finish Date
0	Milestones	1/31/2009	12/31/2014
0.1	Milestone 1: Functional Specification, Controls and Communications		12/31/2009
0.2	Milestone 2: Control and Communications Structure Design		8/31/2010
0.3	Milestone 3: Final Report for Phase 1		3/31/2011
0.4	Milestone 4: Design of Maui Experiment		3/30/2012
0.5	Milestone 5: Report of DMS Performance		7/31/2014
0.6	Milestone 6: Draft Final report		12/31/2014
1	Task 1: Data Collection and Functional Requirements Definition	4/1/2009	3/31/2013
1.1	Collect and estimate Maui substation/feeder data and load profiles	4/1/2009	3/31/2010
1.2	Establish a technical and economic baseline for selected substation and feeders	6/1/2009	2/15/2010
1.3	Compile wind farm energy data	9/1/2009	12/31/2009
1.4	Establish a technical and economic baseline model for wind	6/1/2009	12/31/2009
1.5	Functional requirements specification	4/1/2009	12/31/2009
1.6	Develop Data Flow Diagrams	9/2/2009	3/31/2013
1.7	Real-Time Testing and Experiments	1/4/2010	7/8/2013
2	Task 2: Selection and Sizing of Distributed Energy Resources	7/1/2009	3/31/2013
2.1	Distribution system model	7/1/2009	3/31/2013
2.2	Preliminary identification of DG assets	10/1/2009	3/31/2012
2.3	Sizing and specifications of distributed energy resources	10/1/2009	3/31/2012
2.4	Early Evaluation of controls and Communication Design	7/1/2009	3/31/2010
3	Task 3: Design Controls and Communication	10/1/2009	12/31/2012
3.1	AMI and communications architecture definition	10/1/2009	3/31/2012
3.2	Distribution system control and energy management design	10/1/2009	12/30/2011
3.3	Model-based validation	1/4/2010	3/31/2012
3.4	Control system tuning	4/1/2010	3/31/2012
3.5	Define Interfaces between DER assets and control system	4/1/2010	12/31/2012
4	Task 4: Detailed Design and Implementation	3/8/2010	9/30/2012
4.1	Detailed energy management and control design (DMS)	3/8/2010	9/30/2012
4.2	Detailed AMI and communication architecture design	9/6/2010	3/29/2012
5	Task 5: Factory Acceptance Tests	1/4/2011	9/30/2014
5.1	Define Test Objectives and test Plans	9/30/2012	12/31/2012
5.2	Adapt Control and Communication Infrastructure at Test Sites	7/18/2011	12/31/2012
5.3	Testing and Reporting	7/1/2013	9/30/2014
6	Task 6: Substation site preparation and Feeder Selection	10/1/2009	12/30/2011
6.1	Evaluation and Selection of Feeder Laterals	10/1/2009	2/28/2011

WBS	Name	Start Date	Finish Date
6.2	Substation Design and Environmental Evaluation	6/1/2010	3/31/2011
6.3	Procure Substation Equipment	10/1/2009	12/30/2011
6.4	Site Preparation	9/1/2010	12/30/2011
7	Task 7: Build Substation & procure DER Equipment	4/1/2011	12/31/2013
8	Task 8: Installation and Commissioning	9/26/2011	12/31/2013
8.1	DMS	2/28/2012	2/1/2013
8.2	AMI	9/26/2011	5/4/2012
8.3	Meters	1/31/2012	8/31/2012
8.4	DA	11/1/2011	6/22/2012
8.5	HAN Devices	2/14/2012	10/31/2012
8.6	DRMS	10/31/2011	2/17/2012
8.7	PV Monitoring	2/14/2012	9/28/2012
8.8	Energy Storage	11/1/2011	1/31/2013
9	Task 9: Testing and Demonstration	8/1/2011	4/4/2014
9.1	Define Test Objectives	8/1/2011	1/31/2012
9.2	Develop Test Plan	10/14/2011	3/16/2012
9.3	Perform testing and Monitoring	3/4/2013	9/30/2014
9.4	Demonstrate to Customers and Stakeholders	3/4/2013	4/4/2014
10	Task 10: Project Management and Reporting	4/1/2009	12/31/2014

Figure 4-1: Implementation and Milestone Schedule

5. OUTREACH AND COMMUNICATIONS ACTIVITIES

Communication and outreach was an integral part of the Maui Smart Grid Project and encompassed numerous areas including:

- Participant recruitment
- Customer meetings and outreach events
- Customer feedback
- Workforce development

5.1 Customer Recruitment

Customer recruitment was critical to the project. The ideal scenario was to have a mix of customers that included those with smart meters, participants with PV, participants with in-home devices such as programmable thermostats, monitored appliances, in-home displays, and web portal access. Recruitment of the participants necessitated development of several communication tools (webpages, mailers / tri-folds, fact sheets, etc.), and hosting several events with potential participants. The development and use of these tools were conducted in parallel. Examples of materials developed for community outreach and education are shown in Figures 5-1 and 5-2. This information was provided to potential customers during outreach meetings, mailers, and door hangers and was also available on the Maui Smart Grid website.



Figure 5-1: Maui Smart Grid Project Information Tri-Fold

Maui Smart Grid Project

Description

The Maui Smart Grid Project will demonstrate and evaluate new technologies that will help Maui reduce energy use during periods of high demand, operate the electricity grid more efficiently, restore power outages faster, and integrate more renewable energy.

The U.S. Department of Energy is funding this project as part of a nationwide set of demonstration projects. Maui Electric Company (MECO) and the Hawaii Natural Energy Institute (HNEI) at the University of Hawaii are the two organizations leading the project. The project team has selected Maui Meadows as the site for testing home smart grid technologies with volunteer participants.

The results from the project will be compared with other demonstration projects throughout the U.S. and also used for decision making on future smart grid initiatives in the state of Hawaii.

For project updates please call MEDB, 808.875.2300, ext 6803.

Timeline

June - Aug	Aug - Dec	Dec - Feb '12	Feb - Feb '13
Planning/ Set-up	Participant Recruitment	Technology Deployment	Run

Partners

Figure 5-2: Maui Smart Grid Project Fact Sheet

Maui Economic Development Board (MEDB) had the primary responsibility for working with HNEI, MECO and the other project partners to develop a comprehensive plan for recruiting volunteers to participate in the Maui Meadows neighborhood.

- MEDB developed a website tailored to the project which was designed to educate prospects and the community on the project and subsequently be a resource for volunteers. Although Facebook was added to Internet-based outreach, the time frame of MEDB’s engagement in the project did not allow enough time to attract a following for this approach and was closed down in favor of emails, mailings and calls.
- Supporting material was drafted such as the Project Description and Frequently Asked Questions pieces, incorporated on the website as well as in a handout format.
- MEDB tracked and documented interactions with volunteers.

- In the initial phase of structuring the project operation, the project partners determined that it was most efficient and less confusing for prospects and volunteers to have MEDB field all phone calls and email inquiries. From that contact, MEDB tapped the appropriate partner (e.g. HNEI, MECO, etc.) to help with responses if necessary.
- MEDB joined HNEI in presenting at a Maui Meadows Association Board Meeting and demonstrated samples of the Smart Meter and the other HAN devices. MEDB also attended the Maui Meadows Association Annual Meeting where staff were introduced by the board members and were able to field many questions.

5.2 Community Meetings and Outreach Events

Several community outreach meetings were held with the Maui Meadows homeowners association. These were hosted by HNEI, MECO, and MEDB; they were attended by residents of Maui Meadows. HNEI, MEDB and MECO were very active in outreach and communications throughout the project, meeting with Maui County government and many public interest and citizens groups, writing articles for the Maui newspaper, conducting radio interviews, keeping the website current, setting up displays at numerous Maui community events where HNEI and MECO staff were available to answer questions, etc. Figure 5-3 lists the primary outreach events organized by MEDB.

Time Period	Primary Events Organized by MEDB	Topics
9/2011 – 11/2011	Maui Meadows Homeowners Ass'n Board	Introduce Project
	Maui Meadows Homeowners Ass'n Board	Initial Information Meeting, Q&A
	Community Information	Information, volunteer signups
9/2011 – 9/2013	Monthly coffee groups with volunteers	Field questions, discuss experiences
10/2012 – 12/2012	Meet with initial project volunteers	Project Kickoff
7/2013 – 9/2013	Progress meeting with volunteers	Summarize project progress to date
	Meet with eGauge volunteer participants	Tutorial on eGauge monitors
10/2013 – 12/2013	Progress meeting with volunteers	Summarize project progress to date
7/2014 – 9/2014	Final project meeting with volunteers	Project results, next steps, feedback

Figure 5-3: MEDB Outreach Activities

5.2.1 Launching the Project

To publicly launch the project, MEDB helped organize a Community Information Event at the Kihei Community Center. Eight partners participated: HNEI, MECO, SSN, HNU, SLIM, MEDB, County of Maui, and Alstrom.

- The session was set up with stations for each of the partners so prospects had easy access to partners who could best answer questions about the project: e.g., HNEI could answer questions about the concept; SSN could respond to communication device questions, etc.
- MEDB arranged for Maui's Mayor to briefly address the gathering and express his support for what can be learned from the project.
- Attendees had the opportunity to ask numerous questions, which they did.
- 43 attendees signed in and 16 volunteered at the event.

5.2.2 Continuing Communications with Project Volunteers

As interest in the project built, MEDB staff provided information and guidance to volunteers registering in person, over the phone, by mail, and online.

In late 2011 and early 2012 MEDB focused on communication with the Maui Meadows community and potential volunteers to insure maximum recruitment. A postcard sent out on December 23, 2011 to 761 Maui Meadows residents announcing the extended deadline for participation. A pre-installation letter was sent out on February 16, 2012 to the 104 current participants. Enclosed with the letter were the Participation Agreements, Permit Form (if applicable) and Request for Home Energy Audit. Of those 104, 80 completed their registration paperwork.

MEDB organized the first volunteer session on December 12, 2012 which was designed to hear from the volunteers about their experiences, learn about any questions they have and identify areas that needed attention going forward. Invitations to volunteers were issued through two email blasts, two postal mail notifications, phone calls, and door-to-door visits.

The meeting generated beneficial information to project partners, both positive and negative, and fostered a more convivial relationship between the project and the volunteers who attended. Feedback that was received during this meeting included:

- Volunteers think the Smart Grid is a positive development for Maui's energy future, helping to reduce dependence on fossil fuels, promote energy efficiency, and decrease electric bills
- Volunteers who remained with project are not concerned about alleged health effects after conducting their own research
- Volunteers do not fully understand the goals of the project
- Jargon and technical terminology contribute to confusion
- To some volunteers, project delays have been frustrating and dampened their enthusiasm
- In spite of numerous notifications, some volunteers were not aware of optional equipment
- Some volunteers are still interested in adding optional equipment
- Some volunteers have not used the Web Portal yet
- Volunteers who have used In-Home Displays have found the data interesting and useful.
- More one-on-one interaction would be welcome, e.g., on Web Portal
- Volunteers are confused about large number of project partners and their roles
- Relationship of PV system to Smart Grid isn't clear, causing concern and confusion
- The reduction in energy consumption due to PV installation has diminished some interest in other energy-efficiency practices

MEDB also organized and hosted 3 smaller meetings during the course of the project. All volunteers were sent a postcard and email invitation, followed up by phone calls during the weeks leading up to the event. Volunteer contacts made through the home visit process were also personally invited to the event.

- These meetings shared project news and highlights with volunteers, as well upcoming projects aimed at modernizing Maui's grid and integrating it with new, renewable energy sources.

- These meetings kept volunteers abreast of project happenings while fostering an intimate setting that allowed for one on one conversation with project partners.

In May 2013 MEDB staff members attended a three day “Fostering Sustainable Behavior” seminar hosted by Hawaii Energy at UH West Oahu. This session yielded valuable information which helped shape MEDB’s volunteer engagement plan going forward. The seminar highlighted ways to remove volunteer engagement barriers and create a free flow of information between MEDB and the project participants. MEDB staff was committed to the idea that face to face contact with volunteers was the key to successful relationship building and increased project participation.

Throughout the project, MEDB engaged with project volunteers through numerous contacts via phones calls, emails, and home visits which re-invigorated volunteer interest in the existing devices in their homes.

MEDB communicated with project partners via weekly conference calls providing updates on device maintenance, direct volunteer feedback, upcoming outreach and events and coordinated support for any partner visits, requests or website maintenance.

5.2.3 Home Visits

MEDB accompanied electricians to all volunteer homes during the implementation phase to document any installation questions, provide support for both the installer and participants and develop volunteer relationships.

During this time, MEDB also worked with HNEI, MECO, and the other project partners to develop and implement a communications strategy to promote a positive image for the project to media and the public.

MEDB made close to 300 home visits during the span of the project. The home visits made to MSGP volunteers provided the project with essential feedback that would otherwise have been difficult to obtain. For example, MEDB staff were able to uncover and resolve technical issues relating to the CIQ portal and passwords, answer specific device and project questions and strengthen volunteer relationships through face to face contact.

HNEI requested MEDB obtain five existing volunteers for the installation of the eGauge inverter device. MEDB was able to successfully enroll these volunteers because of the increased trust that had been built through the home visits. MEDB also increased the number of IHD participation due to the visits and conversations with volunteers.

5.2.4 Newsletters

MEDB completed 11 newsletters during the course of the MSGP that included volunteer interviews, project updates, and general industry and energy related topics. (Initially, the plan was for monthly newsletters, but the number was reduced for budgetary reasons.)

- MEDB selected the topics, gathered key information for articles, interviewed volunteers for human interest features, and determined energy facts that would be helpful to volunteers.
- Project partners’ feedback was obtained prior to publication.

- These newsletters were mailed to the entire Maui Meadows community in order to keep them informed of project events. MEDB received positive feedback from volunteers and non-volunteers as well who appreciated the updates on the project and the energy saving tips included in the articles.

5.2.5 Other Media

On April 6, 2014 the Maui Smart Grid project team received news that the group Stop Smart Meters Hawaii planned to canvass the Maui Meadows area in an attempt to decry the MSGP and smart meters in general. MEDB, MECO and HECO immediately took action on a strategy focused on providing clear, concise resources to project volunteers and community members that might wish to research the topic further.

MEDB also reached out to MSGP volunteers through home visits designed to disperse reliable research-based information provided by MECO and HNEI.

MEDB shared MECO's fact sheets regarding smart meters, radio frequency, comparing RF levels and privacy issues as well as HNEI's report detailing the recent radio frequency testing performed by Cascadia PM which clearly states that smart meters do not pose a health risk.

MEDB reached out to all MSGP participants to coordinate home visits and respond to any questions the volunteers may have had, especially about smart meters. Staff responded to volunteer questions on the MSGP, smart meters and electromagnetic radiation. The full report of the RF study findings was published concurrently by Cascadia PM, which all partners saw as an opportunity to bring broader community understanding on Smart Meters. MEDB worked on a press release on the findings and alerted *The Maui News* and other media about the story.

- The findings were posted to the project website along with a press release created by MEDB detailing the process of the RF testing and its results. This press release included quotes from a Maui County Energy Commissioner and a Maui-based energy consultant in support of smart meters and the MSGP.
- The effort resulted in a front page article in the *Maui News* on April 29th on the safety of smart meters in Maui County per the Cascadia report and described the MSGP as an important piece in Hawaii's grid modernization efforts.
- A Maui County Energy Commissioner wrote a *Viewpoint* piece in support of the project and smart technology as a way to reduce both dependency on fossil fuels and energy costs for island residents on May 14th.
- Two MSGP volunteers wrote letters to the editor on May 18th and 26th stating their confidence in the project and their pride in participating in it.
- The Executive Director of the Honolulu-based Blue Planet Foundation also wrote a letter to the editor on June 18th detailing the key role that smart meters play in energy management.
- Other community members unaffiliated with the project wrote letters to the editor expressing support for smart meters and grid modernization. MEDB also provided information in support of the project to be shared at the Maui Meadows Home Owners board meeting on May 16th by the Board president and a MSGP volunteer.

MEDB's concentrated effort found that most of the MSG volunteers were not influenced by the efforts of the Stop Smart Meters Hawaii campaign and felt comfortable in their participation and confident in the project goals.

5.3 Customer Feedback

Customer feedback during the entire project was a critical component. Beyond the technical aspects and challenges, understanding how customers would accept the new technologies and use the available technologies and resources to make informed energy decisions was determined to be equally, if not more important, for overall development of the Smart Grid in both Hawaii and throughout the United States.

The Sustainable Living Institute of Maui (SLIM) at the University of Hawaii Maui College (UHMC) had primary responsibility for developing several customer surveys conducted throughout the project, covering energy usage changes, effectiveness of the energy audits, and usages / acceptance of the available technologies. (Results are presented in Section 6).

Two online customer surveys were conducted over the duration of the program: one with home volunteers who received an energy audit from students, and one with home volunteers who did not receive an energy audit. Home volunteers who signed up for the free energy audit were given pre-audit and six-month post-audit surveys to measure the effects of the energy audit, and to understand their use and comfort with the smart meter technology. The one-time survey of the non-energy audit home volunteers, was administered at the same time, approximately six months after the smart meters and in-home devices were installed.

5.4 Workforce Development

SLIM at UHMC provided energy audits to home volunteers enlisted in the project and enhanced local workforce development in smart grid and energy management training.

Of the approximately 800 homes in the neighborhood, 88 homes signed up for the project and volunteered to have smart meters placed on their homes. All of the homes were given the option to receive a free home energy audit by students in the SLIM UHMC program. Thirty home volunteers with 36 homes (including six guesthouses) volunteered to receive an energy audit. Experts are generally contracted to provide these types of services for projects like the Maui Smart Grid. However, the MSGP partnered with UHMC to help students gain energy management training and valuable real-world experience, with the benefit of supporting the development of a local workforce that can continue to provide similar services to the Maui County community in the future.

5.4.1 SLIM Program Goals

The goals of the SLIM HNEI training program were to:

- Train students in home energy management skills through the Home Energy Survey Professional (HESP) training course;
- Provide students with real-world experience so that they could obtain the Residential Energy Survey Network (RESNET) certification;

- Train a local workforce in energy management to help spur a new industry and create new jobs in Maui County;
- Prepare students to gain employment in the energy management field; and
- Offer free home energy audits to volunteers in the Maui Smart Grid Project as an added benefit.

5.4.2 Energy Audits

The program began one month after students were selected (17 students). It started with a two-week intensive HESP training class. Through the class, students were prepared to take the RESNET exam, a nationally recognized energy management exam. During the training, special attention was given to smart meter technology, including training on the online web portals. This was provided by MECO and given to smart grid volunteers so that students would be able to answer related questions from the home participant volunteers. In addition, students received three extra days of customer service training so that they would be prepared to interact with the Maui Smart Grid Project home volunteers.

Once the students completed the training, and under the supervision of the HESP instructor, they performed energy audits on the 36 homes that had volunteered. Twelve students, in teams of two, conducted home energy audits on 4 to 6 homes. Each student received a \$500 stipend and completed the necessary steps to receive the HESP certification and gain “provider” oversight of Green Training USA LLC.

Prior to the energy audits, home volunteers were given access to their smart meter information through online portals that provided data on their energy use. SLIM students provided assistance to home volunteers in accessing their energy use information through the online portals. The students’ goal was to help each home volunteer recognize, invest in, and install more energy efficient measures.

The HESP instructor supervised each team for their first few energy audits. Throughout the internship, the instructor was on site in the neighborhood to check in regularly with each team as they completed their audits. At the beginning of each audit, student teams met with home volunteers individually and led them through an informational session on their smart meter online web portal to guide them in optimal use. In addition, students reviewed the home volunteers’ electric bills to assist them in gaining a greater understanding of their energy use history and to let them know how their bills could be used to track any problems and make improvements.

After the students met with home volunteers, they inspected their homes for energy efficiency opportunities. To conduct the energy audits, the students used several tools that were consistent with the HESP energy auditing requirements. These included *Kill-A-Watts* to measure appliance energy use; *InfraRed Laser Thermometers* to identify hot spots where insulation was missing or insufficient; *Low-E Coating Detectors* to check for “E-coating” on windows; and compasses and tape measures to measure rooms, windows and doors, as well as check the directional orientation of the home for PV installations and shading issues.

The energy audits included a thorough inspection of the inside and outside areas of the home, including the air conditioning, hot water heaters, pool pumps, outside water features, lighting,

and appliances. They also evaluated other aspects of the home, such as its natural lighting, natural ventilation, natural shading, window quality, insulation, siding, roofing, interior hot spots, and air penetration. The students provided instruction to home volunteers about their hot water heaters and how to set the temperature, timers, as well as potential maintenance requirements in order to be as energy efficient as possible. Water use efficiency measures, such as low flow fixtures, irrigation, and potential leaks, were also discussed with the home volunteers (see Figure 5-4). Many volunteers chose to join the students throughout their energy audit, asking questions that the students could address on site.

- 
- | | |
|--|--|
| <ul style="list-style-type: none"> • Inspection inside and outside of home • Air conditioning • Hot water heaters • Pool pumps • Outside water features • Lighting • All energy appliances • Hot water heater assistance with setting temperatures, timers, and maintenance requirements | <ul style="list-style-type: none"> • Natural lighting • Natural ventilation • Natural shading • Window quality • Insulation • Siding • Roofing • Interior hot spots • Air penetration • Water use efficiency measures (e.g., low flow fixtures, irrigation, potential leaks, etc.) |
|--|--|

Figure 5-4: Energy Audit Components

5.4.3 Student Education Results

The education levels of the students varied in the SLIM HNEI training program. Of the seventeen students who started the program, two students had graduate degrees, two had bachelor’s degrees, two had associates degrees, nine had some college credit, and two students had high school diplomas and no college experience. Fifteen of the seventeen students who started the program were enrolled at UHMC, and two students had taken non-credit energy trainings through SLIM prior to the program. All seventeen students had already gained some introductory knowledge of energy management either from other courses at UHMC or through SLIM.

Most of the students in the program had already entered the workforce. Many of the students had been unemployed or had low income employment and decided to return to school to further their education following the economic downturn.

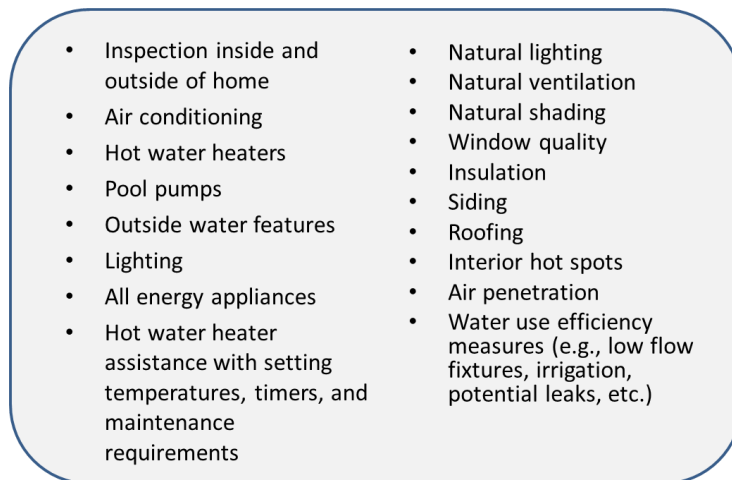
To measure the benefit of the training and internship opportunity, a survey of the students was conducted at three stages: pre-training, post-training, and post-internship. The survey attempted to determine each student’s knowledge of energy auditing skills and techniques at each time. The surveys also questioned the students’ projection of their future professional plans related to the skills they learned in the program.

5.4.3.1 Skill Development

One of the primary goals of the program was to increase student knowledge about energy management and smart grid technologies to prepare students for future work in an energy management field. Prior to the training program, students varied in their knowledge of smart grid technologies and energy efficiency. By the end of the program, all of the students stated that they felt they had “above average” knowledge about energy management (Figure 5-5).

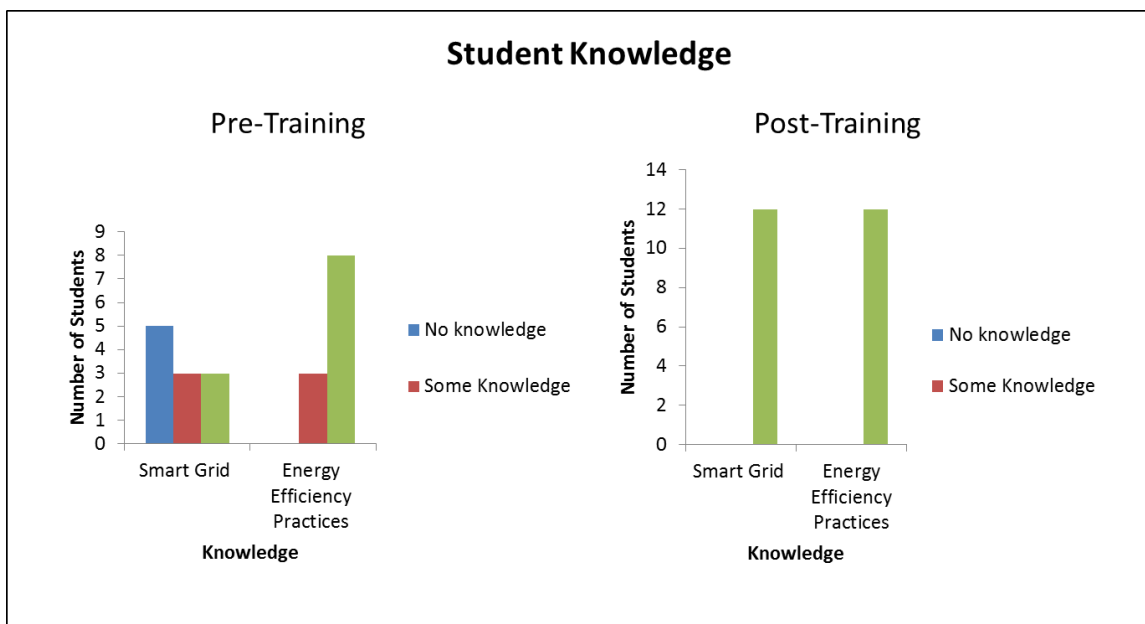

Figure 5-5: Student Smart Grid/Energy Efficiency Knowledge

5.4.3.2 Comfort Level and Familiarity with Energy Management

Figure 5-6 compares familiarity with energy auditing skills before and after the program. Students’ perceptions of their technical skills, customer relations, public speaking, and working with others were measured before and after the training. Overall, students believed that the training improved their comfort level the most in customer relations, followed by working with others, public speaking, and learning the technical aspects of energy auditing.

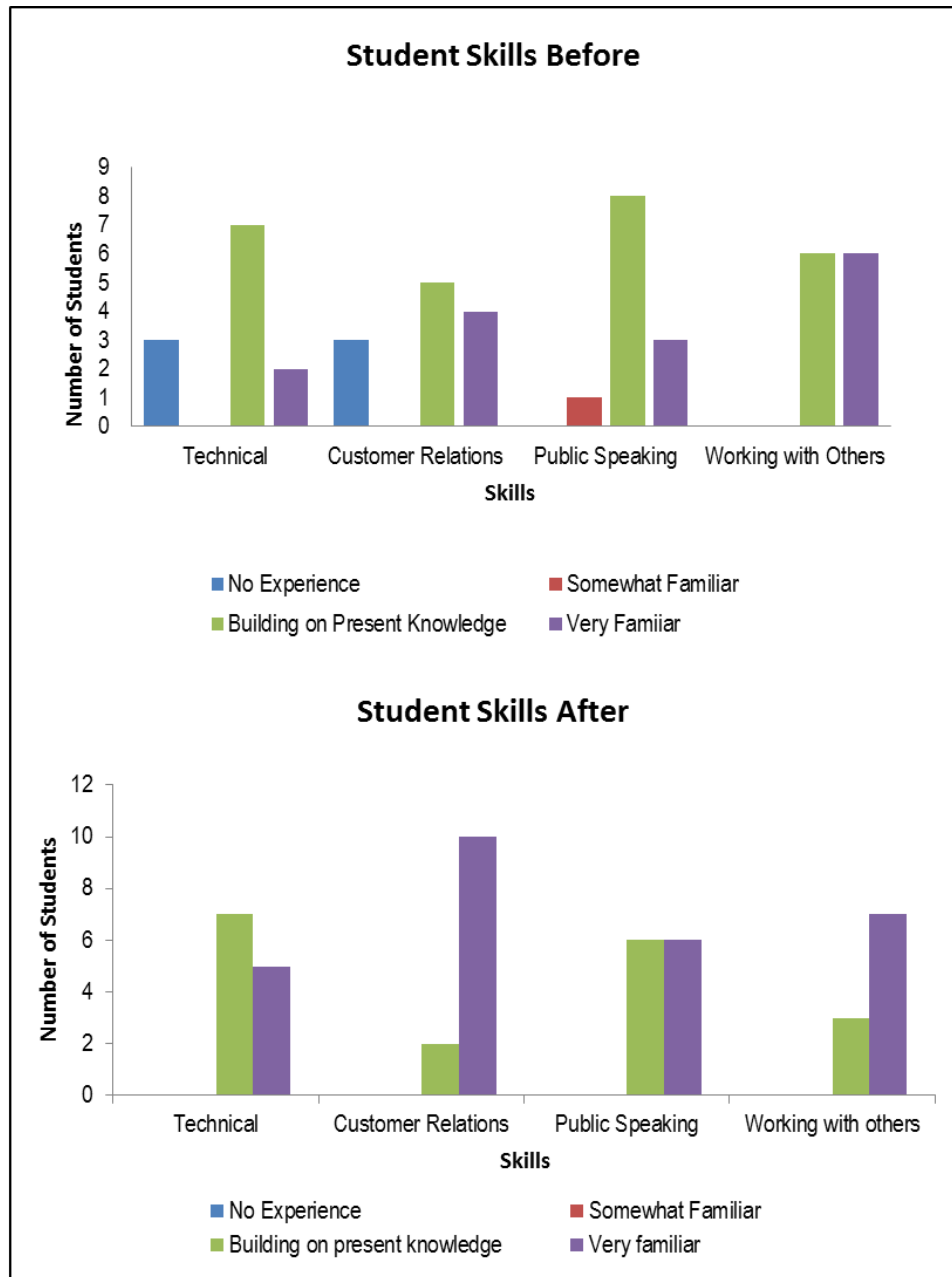

Figure 5-6: Student Familiarity with Skills before and After Training

5.4.3.3 Confidence in Future Energy Management Employment

Students' confidence increased in their ability to translate their new knowledge into viable employment. Figure 5-7 illustrates that before training most students were "hopeful" that they could obtain a job in energy management at the end of the program. By the end of the program, students were more confident that they could gain employment in energy management. While students' confidence increased, their interest in actually obtaining employment in an energy management position varied slightly. Some students' interest decreased, though most students' interest increased. Figure 5-8 shows how student employment interest changed throughout the program.

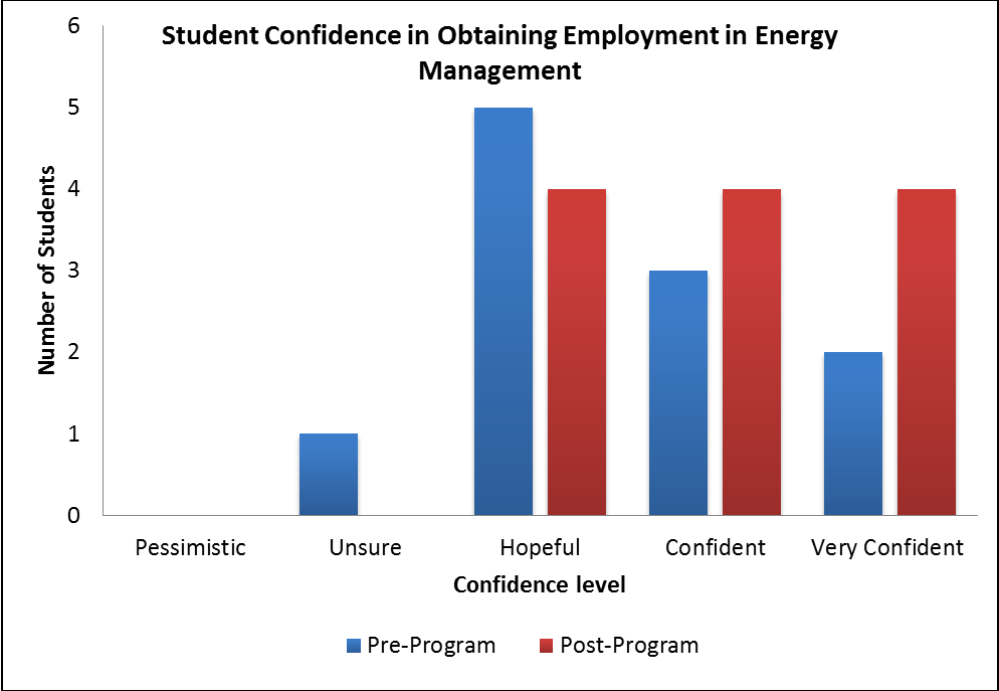

Figure 5-7: Student Confidence

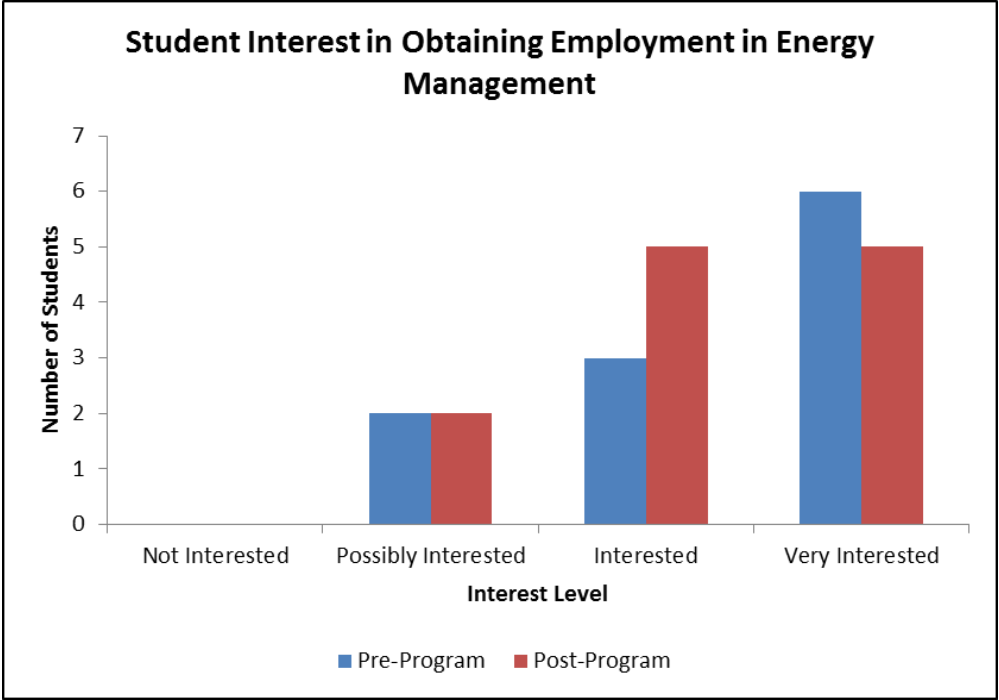

Figure 5-8: Student Interest in Energy Management at Program Completion

6 ANALYSIS AND EVALUATION

6.1 Analysis Plan

6.1.1 Overview & Summary

The project team implemented the following smart grid technologies to achieve the project objectives stated in Section 2:

- AMI
- HAN, which include the following capabilities:
 - In-home displays (IHD)
 - Demand response
- Distributed generation monitoring (through AMI)
- Demand Response (DR)
- Distribution system monitoring (voltage – AMI, current – DMS) and control (volt-var control – DMS)
- Local appliance and premise load profile recording (eGauge system)
- BESS

Summary of Smart Grid Functions Planned in Demonstration					
Objective	AMI	HAN / Web Portal	DR	BESS	DMS / DA
D-1: Reduce Peak Load	Measure Customer Load Profiles – water heater (WH) & air conditioner (A/C)	1. Monitor DG (PV) output 2. Web Portal Feedback 3. Pricing	1. Direct Load Control 2. WH & A/C load profiles through eGauge 3. Appliance response to signal	Peak load reduction	1. Aggregate DER dispatch 2. Measure feeder load 3. Volt/VAr Control 4. Validate distribution feeder load flow model
D-2: Improve Service Quality	1. Monitor and report customer voltage 2. Outage detection	1. Monitor DG (PV) output 2. Monitor monthly home energy use		Reactive power support	1. Volt/VAr Control 2. Validate distribution feeder load flow model 3. Display voltage violations 4. Visualize feeder on operator display
D-3: Inform Consumer Decisions		1. Web Portal Feedback 2. IHD feedback 3. Transmit pricing signals & messages			
D-4: Integrate DER	1. Monitor and report customer voltage 2. Measure PV output	Monitor DG output	1. Reserve Support 2. Off-peak scheduling	1. Reserve Support 2. Off-peak charging 3. Net load following	1. Aggregate/report DG output 2. Monitor voltages/report violations 3. Volt/VAr Control 4. Validate distribution feeder load flow model 5. Reserve Support
T-1: Integrate Transmission level RE		1. Communicate curtailment periods 2. Encourage load shifting	1. Reserve Support 2. Increase minimum system load	1. Off peak charging 2. Discharge during system events	1. Aggregate DER for Reserve Support

T-2: Provide Ancillary Services			Direct Load Control (DLC) during system events	1. Discharge during system events 2. Reserve support	Aggregate/control DER for Reserve Support
T-3: Reduce Transmission Congestion			DLC during system peak	1. Voltage support 2. Discharge during system events 3. Peak load reduction	1. Aggregate/control DER for peak load reduction 2. Monitor and estimate feeder load

Figure 6-1: Summary of Smart Grid Functions in Demonstration

6.1.2 Load and Voltage Profile

The AMI system was the primary instrument for load profile, voltage, and PV analysis. It has several features related to the project objectives of reducing peak energy consumption and improving service quality. The AMI recorded total home net energy use at 15 minute intervals, reported this to MECO, and provided this information to the customer via a web portal. The system also monitored voltage at the customer premises, recorded readings at 15 minute intervals, and reported readings outside of the acceptable range defined by the MECO tariff (+/- 5% of nominal voltage). The AMI system, through a second meter installed on the home, also monitored PV generation and recorded the data at 15 minute intervals.

The AMI system collected performance statistics on these features and provided MECO with the following information and capabilities:

- Record residential load profiles of Maui Meadows participants;
- Demonstrate technical viability and benefits of providing energy use information to residential customers – defined in more detail in Sections 6.1.3 and 6.1.5;
- Demonstrate technical viability and benefits of monitoring customer voltages and power quality measures;
- Provide operational experience with reliability and latency of AMI meter reads; and
- Record residential PV generation profiles of Maui Meadows participants – defined in more detail in Section 6.1.4.

6.1.2.1 Load Profile

The AMI load data provided a detailed record of whole-home energy use by project participants (about 80 customers) for at least a 12 month period. The project team analyzed these data over several time scales, including hourly, daily, weekly, and monthly. This analysis of whole-house loads helps MECO to plan system needs based on a current sample (non-representative) of customer profiles. For the homes (6) with PV metered, the project developed load profiles for total energy use and net energy purchased from the MECO grid. For homes with PV but not metered PV, estimated total house load profiles were developed by using the average of the 16 metered PV sites, scaled by PV nameplate in the homes.

The meter data was used to develop load profiles characterized by:

- Hour of the day
- Day of the week (weekday versus weekend/holiday)
- By month, season, and/or average daily temperature or other weather variables (wet bulb)

Individual whole-house data were also analyzed to compare variation among project participants and correlated with customer information, including new information collected through surveys and energy audits).

The resulting load profile data was compared with existing MECO residential class load characteristics used for system planning and forecasting. The derived load profiles will not be a representative sample of MECO residential customers because of the limited sample size and method of recruitment (volunteer participation in a specific geographic area).

6.1.2.2 Voltage Analysis

The project team compiled and analyzed voltage profile data over several time intervals, including voltage violation reports. This analysis included:

- Analysis of time and frequency of violations
- Trend analysis of violations

6.1.3 Customer Energy Use

An important evaluation component of the MSGP is to measure the effectiveness of the smart grid technology on reducing home energy consumption. Data from August 2011 to July 2013 were used to indicate the energy usage before the start of the project and one year after it started. Energy use data were collected for all homes in the MSGP and also non-volunteer homes located in the Maui Meadows subdivision who did not participate in the MSGP. These non-volunteer homes represent a control group that do not have a smart meter or in-home device installed. Information on non-volunteers was obtained from MECO billing records. The purpose of the energy use data was to assess the differences between:

- Maui Smart Grid Project volunteers (both audited home volunteers and non-audited home volunteers) vs. Non-MSGP volunteers
- Maui Smart Grid Project volunteers who received home energy audit vs. MSGP volunteers who did not receive home energy audit
- Maui Smart Grid Project volunteers with an in-home device vs. MSGP volunteers without an in-home device

6.1.4 PV Profile

With the continued growth in number of residential PV systems installed, MECO needed to better understand real-time output of PV systems and potential impacts on the distribution grid. The overall analysis of the data collected from the residential PV inverters:

- Characterized PV output (as percentage of nameplate) over the day and by month throughout the year.

- Developed an average PV output profile (weighted average of 7 monitored PV installations).
- Developed statistics about expected local variability of PV output and PV output versus nameplate.
- Correlated average Maui Meadow PV profile with Wailea irradiance measurement.

6.1.5 Home Area Network and Customer Web Portal

The HAN provided customers with information of home net energy use and allows MECO to send messages to customers. The web portal informed customers of their net energy use and provided information on PV output and total home energy use. Collecting information on customer web access statistics and customer feedback (via interviews) provided MECO and the project team with the following information and capabilities:

- Demonstrated technical viability and evaluate benefits (to customers) of Web and HAN and compare results of the two; and
- Operational experience with HAN system to evaluate for potential broader utility applications.

The project team supplemented the operational HAN system data with survey data to better understand participant interaction and satisfaction with HAN equipment tested in the project. The objective was to understand how the HAN devices and IHD have affected customer energy use. The survey questions will also help determine what information the customer found or would find useful and what information is less important.

The HAN / customer-focused research questions are separated into two main areas. The first area focuses on the customer experience with the energy information Web portal (SSN's Customer IQ – CIQ systems). The second area focuses on the customer experience with the in-home display (IHD). Figure 6-2 summarizes the HAN and web portal analysis.

Summary of Home Area Network (HAN) / Web Portal Analysis					
Area of Interest	Key Research Question	Test / Evaluation Methods	Metrics	Data Required	Project Objective
Web Portal Feedback	How many times did the customer log-on?	Distribution of usage; Change in usage by customer; Variation across customers and by customer characteristics	Number of logons over time to evaluate usage	Customer log-on counter	D-1: Reduce Peak Load D-3: Inform Consumer Decisions
Web Portal Feedback	What did the customers like and dislike about the web portal? What other information should be presented on the customer web portal?	Aggregated results, content analysis	Customer satisfaction with portal information	Customer Survey & Interviews	D-1: Reduce Peak Load D-3: Inform Consumer Decisions
Web Portal Feedback	What could be improved to provide a more useful experience for the customer?	Aggregated results, content analysis	Customer satisfaction with portal information	Customer Survey & Interviews	D-1: Reduce Peak Load D-3: Inform Consumer Decisions
Web Portal Feedback	Did the customer use the information to better manage energy usage?	Energy use (monthly) and load profile by customer characteristics, content analysis	Customer satisfaction with portal information; Pre-and post-installation energy use; log-in profile	Customer Survey & Interviews; monthly bill analysis (Combined with Load Characteristic analyses)	D-1: Reduce Peak Load D-3: Inform Consumer Decisions
IHD feedback	What did the customers like and dislike about the in-home display? What other information should be presented on the IHD?	Aggregated Results – numerical scores and content analysis	Customer satisfaction with IHD information	Customer Survey & Interviews	D-3: Inform Consumer Decisions
IHD feedback	Did the customer use the information to better manage energy usage?	Energy use (monthly) and load profile by customer characteristics, content analysis	Customer satisfaction with IHD information; Pre-and post-installation energy use; log-in profile	Customer Survey & Interviews; monthly bill analysis (Combined with Load Characteristic analyses)	D-1: Reduce Peak Load D-3: Inform Consumer Decisions
Utility communications to customer	Are pricing signals and/or curtailment periods received and displayed on IHD and portal? Did the customer respond to the messages?	Verification that messages were received. Did the customer act on the message?	IHD messaging performance and reaction of customer to the messages Customer satisfaction with IHD information	Customer Survey & Interviews	D-3: Inform Consumer Decisions T-1: Integrate Transmission level RE

Figure 6-2: Summary of Home Area Network (HAN) / Web Portal Analysis

6.1.6 Demand Response/Load Control Research and Analysis

6.1.6.1 Overview and Summary

The DR research and analysis focused on two main areas. The first is a characterization of the load profiles of specific appliances: air conditioners (A/C) and electric hot water heaters (WH). This information allowed MECO and consumers to better understand the load profiles (beyond whole-house profiles) of where and when energy is being consumed. The second focus was the response to direct load control signals sent to specific appliances within the study area. Exercising the DR system and collecting performance statistics provided MECO with the following information and capabilities:

- Better characterize diversified load profiles of residential A/C and electric WH
- Technical feasibility and expected benefits of controlling non-critical A/C and WH loads; benefits evaluated included peak reduction, up-reserves (due to load reduction), and managing WH to increase late night system load in order to reduce the need to curtail wind
- Estimate (by time of day and day type) available DR load curtailment and persistence of that load reduction
- Response time for load curtailment commands
- Success rate of load curtailment commands
- Comparison of estimated curtailable load vs. actual curtailed reduction

6.1.6.2 DR Research and Analysis Plan

The following section describes in more detail the planned analysis and reporting of the results for the DR technologies.

Summary of Demand Response (DR) Analysis					
Area of Interest	Key Research Question	Test / Evaluation Methods	Metrics	Data Required	Project Objective
Direct Load Control	Did appliances respond to direct load control signals?	<ol style="list-style-type: none"> 1. Evaluation of appliance status (SSN UIQ system reports response to requested DLC event) 2. eGauge appliance load data. 	<ol style="list-style-type: none"> 1. Appliance turn off/on 2. Change in Programmable thermostat set point 	<ol style="list-style-type: none"> 1. DR commands sent 2. UIQ record of appliance response 3. House load profiles 4. eGauge load profiles 	D-1: Reduce Peak T-2: Provide Ancillary Services T-3: Reduce Transmission Congestion
Direct Load Control	How much was load reduced during each load control directed event? How much energy demand was not served?	Calculated energy reduction based on appliance profiles	Energy savings in kWh per event	<ol style="list-style-type: none"> 1. DR commands sent 2. eGauge load readings 	D-1: Reduce Peak Load T-2: Provide Ancillary Services T-3: Reduce Transmission Congestion

Summary of Demand Response (DR) Analysis					
Area of Interest	Key Research Question	Test / Evaluation Methods	Metrics	Data Required	Project Objective
Direct Load Control	Latency – How fast was the response to DLC command	Since LCS and T-stat cannot be queried, this will rely on SAT results.	Command send time & Command execution time	Site Acceptance Tests (SAT) results for DR function	D-1: Reduce Peak Load
Direct Load Control	Success rate in receiving command	Since LCS and T-stat cannot be queried, this will rely on SAT results.	% successful message transmittal	1. SAT results for DR test 2. UIQ data on response	D-1: Reduce Peak Load
Appliance Load profiles	Load characteristics of electric Water Heaters and Air Conditioners	Observe eGauge-monitored appliance load before and after DR commands.	1. Updated profiles of A/C and WH 2. Build appliance DR response models	1. eGauge data 2. Outside air temperature or other weather indicators	D-1: Reduce Peak Load

Figure 6-3: Summary of Demand Response (DR) Analysis

6.1.6.3 Direct Load Control

Based on initial appliance load profile data (obtained in the first months of the demonstration period and from previous load research studies), a series of appliance load control actions was selected. These were designed to observe the immediate load reduction due to control, the persistence of that reduction, the amount of load recovery (“payback”) after control is stopped, and any customer reaction to controls (e.g., uncomfortable temperatures, ran out of hot water, didn’t notice anything). The controls included:

- Disabling electric water heaters for a pre-defined period (usually 60 minutes, OFF period to be set with MECO concurrence); and
- Adjusting thermostats by about 3 degrees for 60 minutes at times of day of expected peak residential A/C usage.

The number and range of tests was limited by the small sample size (i.e., number of volunteers for load control).

The intent of the DR analysis was to characterize the expected demand response by appliance. This was used to assess the viability of DR to accomplish the overall project objectives: peak load reduction, voltage support, compensating for variability of renewable energy resources, and providing operating reserves. MECO used the results of this limited pilot test to help determine which DR strategies (appliances, control actions) would be appropriate for a MECO DR program, and what would be the benefits of such DR strategies (cost reduction, reduced use of fossil fuels, ability to compensate for variability of renewable energy, etc.).

6.1.6.4 Appliance Load

HECO/MECO had estimates of A/C and electric WH load profiles based on previous load research studies. These were supplemented with load research and demand response data obtained by other utilities to develop estimated load profile characteristics of these appliances and set the test protocol for DR controls. (eGauge data loggers were installed on appliances in five participant homes. eGauge measurements were also used develop the DR dispatch tests.)

The objective was to be able to characterize the demand response resource for two dispatch modes:

- Specific to peak load reduction (i.e., expected DR resource at time of system peak)
- System event-based, such as drop off in wind farm output or loss of a transmission line (i.e., expected DR resource at any hour of the day)

6.1.6.5 Draft Experimental Protocol for Maui RDSI Demand Response System

Equipment and Systems

The DR capabilities for the test system address electric WH and central A/C.

Water Heaters

The DR system was used to disable electric WH with storage capacity. A 240 volt load control switch (LCS) was installed. Instantaneous water heaters and solar water heaters were not controlled. A priori, a WH load profile based on previous HECO/MECO load research was be used to set initial control periods.

Air Conditioners

The DR system reduced A/C loads by raising the thermostat setting by about 3 degrees Fahrenheit. The homeowner could circumvent the control by manually lowering the thermostat setting. Window air conditioners (with thermostats integrated into the appliance) were not controlled.

eGauge Data Loggers

Data loggers were installed on the appliances of five volunteers. With the small sample size of controlled appliances, the latency and recording interval of the AMI system are too large to develop accurate estimates of the load profiles and command response characteristics of WH and A/C. The eGauge data loggers provided 1 minute energy use data of the monitored appliances. (Sampling intervals between a few seconds and an hour are possible.) By correlating the recorded appliance energy use with the time-stamped load control commands, the response of WH and A/C to DR was evaluated.

6.1.6.6 Summary of DR Experiment

DR Objectives

The objectives of the DR demonstration in the MSGP were:

- To obtain updated information on residential WH and A/C appliance load profiles.
- To determine the amount of curtailable residential WH and A/C load by time of day.
- To determine the “payback” or increase in WH and A/C loads after DR control ends.
- To determine the ability of DR to reduce peak load or otherwise provide operational support for the MECO system.
- To demonstrate the feasibility of estimating the magnitude of the DR resource and communicating that information to the MECO system operator.

- To obtain performance data on the pilot DR system, including success rates in transmitting and executing curtailment commands and time needed to effect a demand reduction.

Desired Results

Based on the choices of the approximately 80 volunteer participants in the project, the number of controlled A/C and WH was expected be less than 20 each. The number, test period, and self-selection method of the volunteers' means that the data collected on appliance load profiles and energy use may be indicative of the residential class, but were not a statistically significant representation of those class load profiles. With that caveat, desired results of the DR demonstration were to obtain the following data and answer the following questions:

1. What are the typical load profiles (i.e., hourly diversified loads) of A/C and electric WH?
2. How much load reduction (by hour of the day) can be expected from controlling WH and A/C?
 - How quickly can that load reduction be obtained?
 - How much does the load rebound (i.e., payback) after load control is ended?
 - What is the effect on feeder voltage profile from load control (to be determined by modeling)?
3. How long can WH and A/C loads be controlled before customer comfort is affected?
4. How should DR be scheduled to reduce system peak load? Feeder /substation peak load?
5. How long could DR allow the MECO system operator to delay a decision to fast start-up a diesel?
6. What is the success rate of DR commands to the LCS and adjustable thermostats (SAT results only)?

Experiment Precursor

The basis for the characterization of the DR resource were tables showing by hour:

- The estimated diversified load available for control by appliance
- The estimated diversified load payback after control is ended

The load control “events” to be tested were disabling WH for 60 minutes and raising the A/C thermostat setting by 3 degrees for 60 minutes.

Initial estimates of appliance load profiles and DR characteristics were needed to develop these tables. (The information obtained during the performance test period helped MECO to update DR response estimates in preparation for system-wide DR implementation. eGauge data loggers provided additional information to qualitatively verify whether Maui Meadows appliances actually responded to DR commands as estimated.)

The sources for the base WH and A/C appliance load profiles were previous load research studies done by HECO and MECO, initial eGauge monitoring of five Maui Meadows homes, and other reported utility load research studies in comparable climates and homes. Initial estimates of the change in appliance loads resulting from DR commands (both initial load reduction and later demand payback) came from other utility load control demonstrations and load model simulations.

6.1.6.7 Initial Diversified Appliance Load Profiles and DR Impacts

This section consists of estimates for WH and A/C showing, for each hour:

- Diversified baseline load
- Estimated diversified load (for current hour and next hour) if a load control event is initiated in that hour. The load control events will be:
 - Disable WH for 60 minutes
 - Raise A/C thermostat setting 3 degrees for 60 minutes

Water Heater: Weekday or Weekend

WH base load profiles were derived from the HECO submission on 31 March 2011 for Docket 2007-0341.

WH load reductions per water heater for a 1 hour interruption assume zero diversified WH load for the hour after the DR command. Lessened total system DR response due to weak signal, malfunctioning equipment, or other reasons is not considered. WH connected loads were assumed to be 4 to 4.6 kW, average of 4.3 kW.

The HECO filing estimates load profiles for curtailable load from electric water heaters. The WH load profiles were similar month to month, usually less than 10-15% differences (although peak hours in May are significantly lower than the rest of the year). The WH load profiles from the HECO filing (KEMA Report) are given below. Those curves form the basis of the estimated DR resource from WH, given in the table following the figures.

As data from Maui Meadows homes were obtained and analyzed after the performance test period, the table was updated, to differentiate by season and by month, as part of MECO's evaluation of the system-wide potential for demand response.

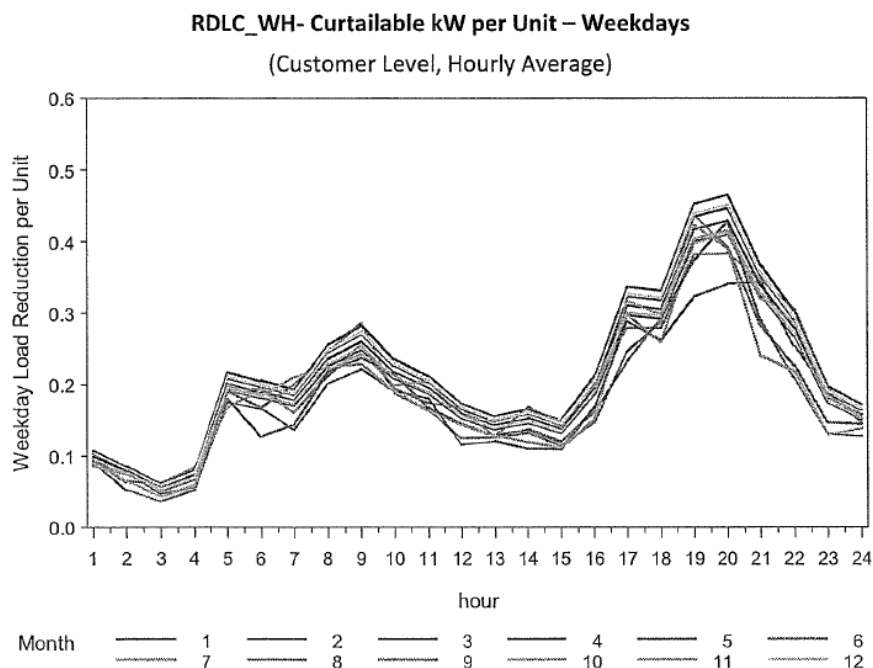

Figure 6-4: Weekday WH load profiles from HECO Docket 2007-0341 submission of 3/31/2011

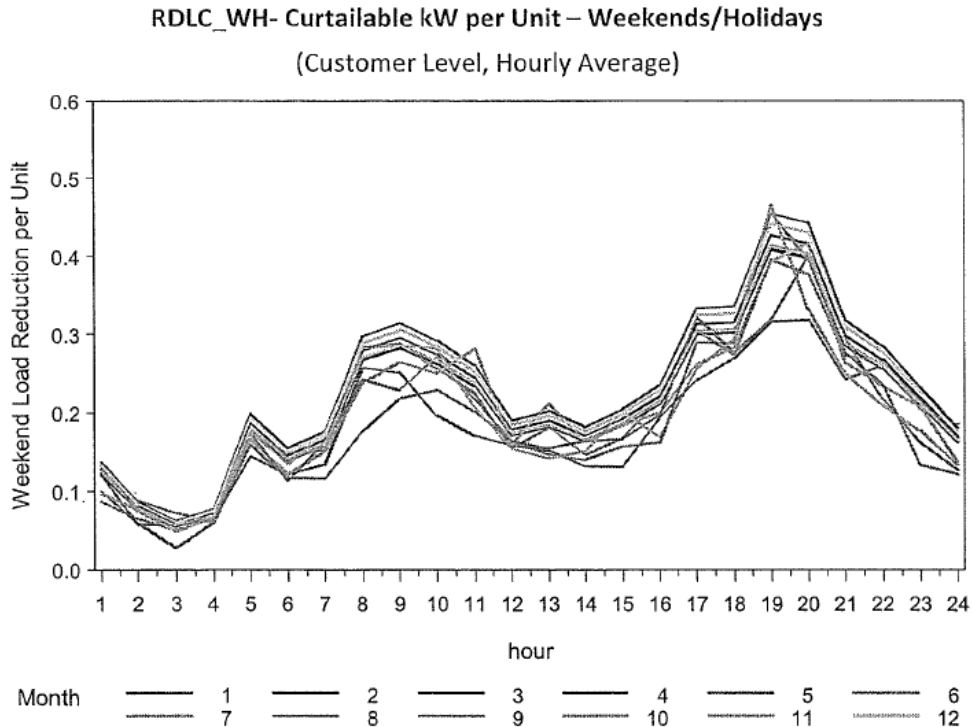

Figure 6-5: Weekend WH load profiles from HECO Docket 2007-0341 submission of 3/31/2011

The increase in diversified WH load after the end of the 1 hour DR event assumed no loss in total energy consumed by the WH. The assumed “payback” characteristics utilize load research and WH models simulation from mainland utilities (Baltimore, Missouri, Virginia).

For payback, after the 1-hour control period ends, the diversified water heater load one expects will be the base diversified load for the next hour, plus the load of the water heaters “catching up” for the hour they were turned off.

To estimate the payback, we examined the dynamics of water heater operation within the hour. Residential water heaters (3 to 5 kW elements) are generally designed to replenish hot water within 15 to 30 minutes. Assuming a 4 kW heating element, a diversified load of 0.1 kWh over an hour could be the result of 10 % of the WH operating for 15 minutes within that hour: during any of the four 15-minute periods within the hour, 2.5% of the WH are recharging with a load of 4 kW for 15 minutes:

$$[0.025 \times \text{total \# WH}] \times [4 \text{ kW load per WH} \times \frac{1}{4} \text{ hour}] \times [4 \text{ 15 minute periods/hour}] = 0.1 \text{ kWh}$$

If the WH are turned off for an hour where the diversified load is 0.1 kWh, then 10% of them would be on for the first 15 minutes after control ends, plus (if the diversified load of the next hour is also 0.1 kWh) 2.5% of the WH would be operating normally during that first 15 minute period (i.e., 12.5% of WH will be on that first 15 minutes).

Where this becomes complicated is when diversified WH load is high (i.e., many WH are normally on). Consider the case of an hourly diversified load of 0.8 kWh. This means that during

any given 15 minute period, 20% of the WH are on. At the end of the control hour, the 80% of the WH that would have operated during that hour will come on, plus the 20% that would normally be on during that 15 minute period immediately following the end of control (assuming a 0.8 kWh diversified load during the next hour, too). In this case, it is likely that all of the deferred WH energy from control would not be “paid back” in the first 15 minutes, but some will carry over to the second 15 minute period. (e.g., 90% of WH payback occurs in minutes 1-15 after control ends, and 10% occurs in minutes 16-30).

Hawaii’s higher ground water temperatures result in lower diversified water heater loads than most mainland utilities. The highest monthly diversified WH load is 0.465 kW/unit (HECO filing, KEMA report page 1-2, average January weekday 7-8 PM). This “translates” to about 60% of the WH operating during the first 15 minutes after control ends. Therefore, the *a priori* WH load curves assumed that all deferred WH energy is added to the MECO system load during the first 15 minutes after the control ends.

AC Load Profiles and DR Impact

While there are numerous mainland utility load research studies that provide load profiles of residential central A/C, it is doubtful that any are applicable to Hawaii, with its mild but humid climate. In HECO’s March 31, 2011 filing to the PUC (Docket 2007-0341), the report by KEMA used monitoring of some military housing on Oahu to estimate residential central A/C load profiles. In addition, the University of Hawaii (UH) has monitored appliance energy use in 16 military homes (using eGuage equipment). It is recognized that Oahu military housing has significantly different construction, HVAC systems, occupancy characteristics, and demographics than the typical Oahu or Maui home. However, this section adapted the findings from the UH studies and KEMA report to provide a starting point for the A/C DR dispatch. After load data MSGP homes’ A/C were collected, the load profiles (and estimated DR resource and impact analysis) were updated to provide guidance for the requirements and impacts for a MECO system-wide DR program.

The average diversified residential A/C load in the KEMA Oahu military housing study does not vary much by weekday versus weekend/holiday (see below). While large variations are seen by month, much of this has to do with changing weather rather than the month itself; the A/C load is most influenced by the daily temperature/humidity index.

The dynamics of the residential A/C when the thermostat setting is raised by 3°F for one hour:

- A/C load immediately goes to zero.
- As the interior temperature rises (quicker when outside temperature is high), the A/C will re-start. However, the duty cycle will be less than with the original thermostat setting (unless it is extremely hot and the A/C is undersized for the house).
- A steady state will be reached, where the A/C is cycling to maintain the indoor temperature at the higher set point.
- At the end of the hour, when the thermostat is returned to its original setting, the A/C will operate constantly for a period of time to lower the interior temperature by 3°F. (This time will be longer during times of high outdoor air temperature.)
- Not all the reduced energy consumption from the hour the thermostat was at +3°F will be used to bring the house interior temperature down to the original thermostat setting. The amount overall energy consumption is reduced will be more for control implemented

during days and hours of high temperatures. (Past field measurements and simulations suggest up to 25% of the energy “deferred” during a hot control hour will not be paid back during the subsequent hour.)

RDLC_CAC- Curtailable kW per Unit – Weekdays (Customer Level, Hourly Average)

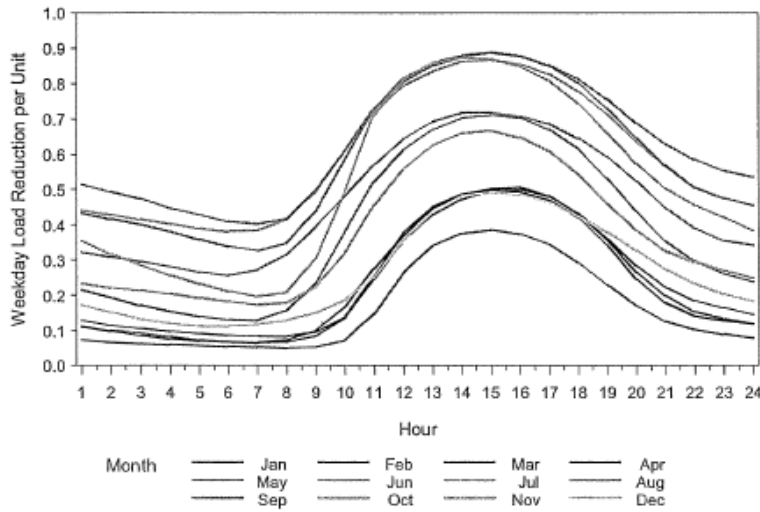

RDLC_CAC- Curtailable kW per Unit – Weekends/Holidays (Customer Level, Hourly Average)

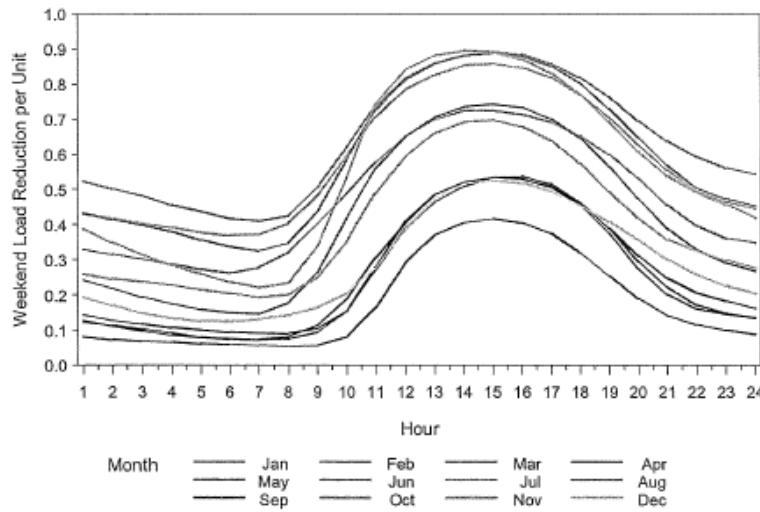

Figure 6-6: Estimated residential A/C load profiles

Typically, residential A/C load research and load control studies categorize A/C load profiles by “hot,” “medium,” and “mild” temperature days. In analyzing the UH A/C data, maximum daily temperature at the airport was the variable used to “classify” the type of day:

- Hot day = maximum daily temperature (MDT) at airport 85 °F or above
- Medium day = 85 °F > MDT > 80 °F
- Mild day = MDT ≤ 80 °F

During the performance test period, DR for residential A/C was exercised during the hour of expected highest diversified residential A/C load: 3 to 4 PM (1500 – 1600). During this time, the average A/C energy use per house was approximately 0.9 kWh for hot days.

6.1.7 Battery Energy Storage System (BESS)

6.1.7.1 Introduction

MECO installed a 1 MW, 1.23 MWh BESS near the Wailea substation on Feeder 1517 as part of its cost share for the MSGP. (Due to the battery’s operating restrictions, the usable BESS capacity is limited to 1 MWh.) Utility-sized BESS is a technology regarded as key for the “Smart Grid,” but utilities do not yet have very much field experience with BESS. As a distributed resource for the project, the BESS has the potential to contribute to peak reduction and voltage support (i.e., improved service quality) goals, enable the MECO system to support more as-available renewable energy resources by mitigating their variations, and improve bulk power grid efficiency by reducing transmission congestion and helping MECO dispatch more efficient generation resources.

A major benefit of the project was very basic: giving MECO a chance to observe and evaluate the effects of BESS on the distribution and transmission/generation systems, in order to identify and quantify the technical and economic benefits of utility-scale energy storage. The focus of the research related to BESS involved analysis of operational data to evaluate effectiveness in performing planned functions.

6.1.7.2 Objectives

The primary objectives of the BESS demonstration were:

- To demonstrate the ability of BESS to supply voltage/VAR support to the feeder/substation during system peak load, thus effectively reducing feeder peak load.
- To evaluate the ability of BESS to support feeder voltage during high loads, especially in comparison to other methods, including capacitors (fixed and switched), tap changer control, and demand response.
- To employ BESS for power smoothing at the distribution transformer, thus mitigating variations in renewables (e.g., wind farms).
- To develop an energy storage dispatch (charge/discharge) strategy to optimize generation production costs or minimize amount of wind energy curtailed at night.

Figure 6-7 presents a description of the BESS-related research questions, sources of information to address the questions, and a summary of the analysis procedures.

Battery Energy Storage System (BESS)					
Area of Interest	Key Research Questions	Test / Evaluation Methods	Metrics	Data Required	Project Objective
Feeder Peak Load Reduction from BESS	How much can BESS reduce feeder and system peak?	1. Discharge BESS at selected times to measure load reduction possible based on historical or forecasted load shape. 2. Use system and substation load shapes to determine how to	kW and % reduction in load during the BESS discharge test.	1. BESS capacity and energy used 2. System, substation, and feeder loads before, during and after BESS discharge	D-1: Reduce Peak Load T-2: Provide Ancillary Services T-3: Reduce Transmission Congestion

Battery Energy Storage System (BESS)					
Area of Interest	Key Research Questions	Test / Evaluation Methods	Metrics	Data Required	Project Objective
		dispatch BESS (without exceeding deep discharge limitations) to minimize system (1900 – 2100) and residential/substation (1700 – 2200) loads.			
Production dispatch of BESS off-peak	How much curtailed wind energy is available to charge BESS?	Identify times when MECO curtailed wind generation and estimate amount of energy curtailed. Develop a summary of frequency, duration, and amount of wind curtailments. Obtain estimate of nighttime marginal power cost from MECO to ascertain the cost to charge BESS.	1. Amount of curtailed wind energy 2. Cost to charge BESS off-peak	1. Historical wind curtailment by MECO 2. MECO nighttime energy costs	T-1: Integrate Transmission level RE
Determine the cost to charge BESS	Determine the cost of BESS energy.	Obtain average marginal cost during night-time hours and multiply by charging / discharging round trip efficiency.	1. Average cost of energy supplied by BESS 2. Reduced transmission loss & loading (per kW of substation load) when using an off-peak-charged BESS	1. Marginal cost of generation during low load periods 2. BESS charge/ discharge efficiency 3. Transmission Loss Factor to Wailea substation	T-1: Integrate Transmission level RE T-3: Reduce Transmission Congestion
Voltage and Reactive Power Support	Can BESS provide voltage support to the feeder/sub during system peaks?	Use BESS to support sub/feeder load during the system peak and determine if feeder voltage was maintained better with local power injection. During peak system load measure changes from before and after BESS starts discharging	1. Transmission loading to substation (real and reactive power, losses) 2. Feeder voltage profile and voltage alarms	Before & during discharge: 1. Transmission line loading (and loss calculation) 2. Feeder/sub. load 3. Feeder voltage profiles 4. BESS discharge rate 5. LTC setting	T-3: Reduce Transmission Congestion D-1: Reduce Peak Load D-2: Improve voltage regulation and power quality
Load following	Can BES “smooth” load & RE variability?	Set a “target” load level for Feeder 1517 and dispatch BESS to maintain that level by charging and discharging.	1. Feeder load target 2. Amount of time BESS can maintain feeder load at target level	1. Target feeder load 2. BESS charge/discharge kW by time 3. Amount load varies from target without BESS	D-1: Reduce Peak Load D-4: Integrate DER T-2: Provide Ancillary Services

Figure 6-7: BESS Research Objectives

6.1.7.3 BESS Installation on Feeder 1517 (Maui Meadows)

BESS is located close to distribution transformer feeding the circuit 1517 shown in Figures 6-8 and 6-9. It is connected to the distribution system via a 480V/12kV transformer which transfers the battery power to the grid. There is a stiff transmission line connected via TSF4 distribution transformer which provides the load to the circuit. The peak shaving and voltage regulation is done on this transformer and the transformer data such as active and reactive power, voltage and current are transmitted through SCADA to a server at MECO. The data was analyzed by the algorithm and optimal control commands were transmitted to BESS to reach the planned objectives. The average active and reactive load for 24 hours based on six month data is depicted in Figure 6-10.

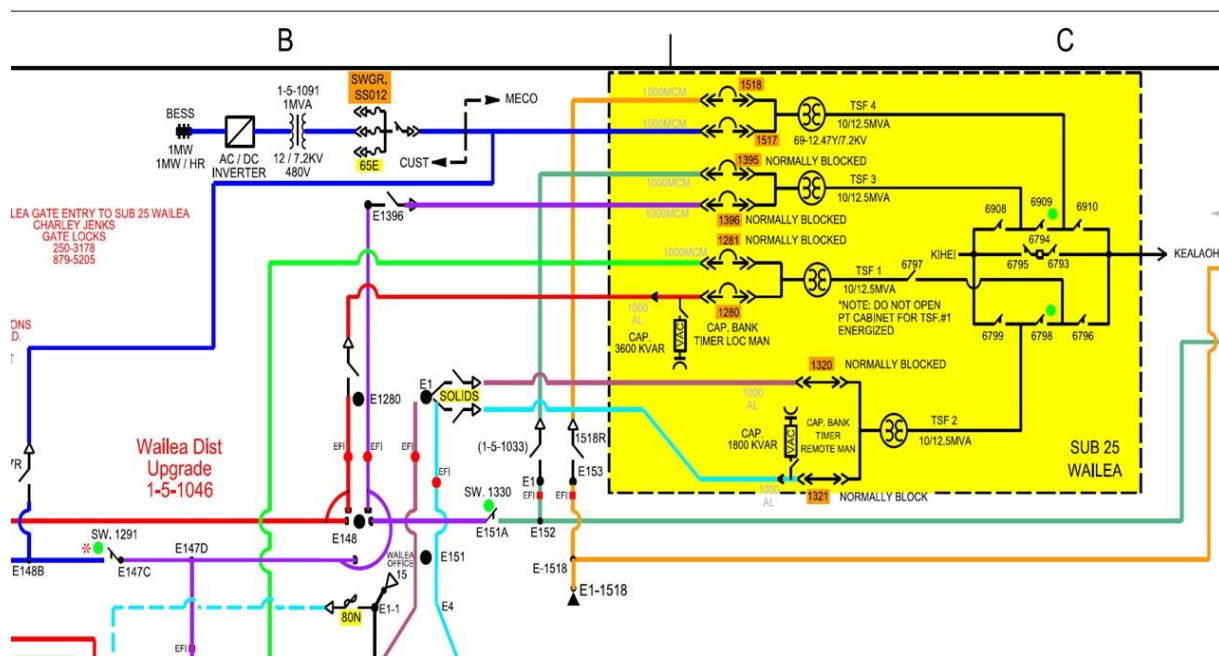

Figure 6-8: BESS circuit diagram showing connection to distribution transformer



Figure 6-9: BESS installation in Wailea substation

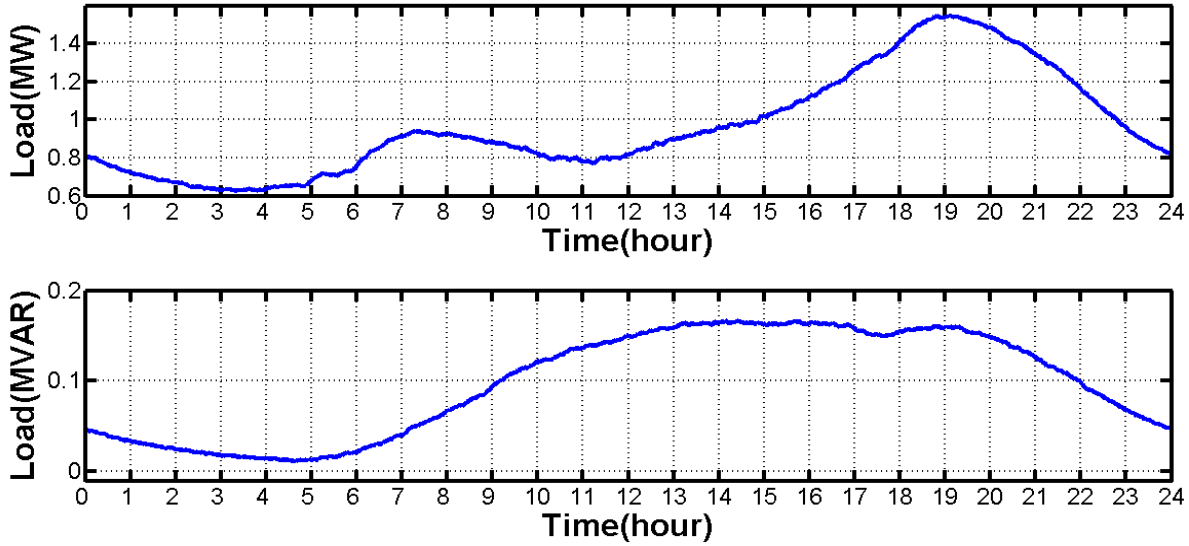

Figure 6-10: Average active and reactive load of circuit 1517

6.1.7.4 BESS Description

The BESS for the MECO Wailea project consisted of a 1 MW Power Conversion Subsystem (PCS), a 1.23 MWh Lithium Ion battery (limited to 1 MWh in operation), and one control group consisting of local control algorithms and EMS dispatch control. The battery has 12 battery racks, which are wired in parallel to create a single DC bus. The DC bus is then connected to the PCS, and the PCS is connected to the grid through a 480V/12.47kV transformer. Figure 6-11 presents the BESS system architecture diagram for the MECO Wailea project.

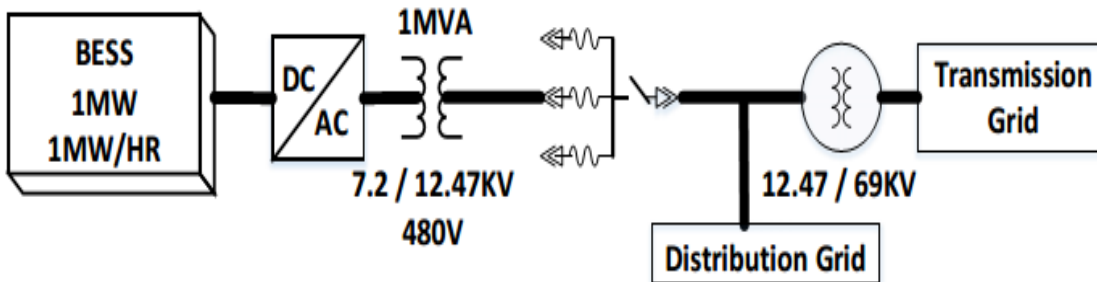

Figure 6-11: BESS system architecture diagram for the MECO Wailea project

6.1.7.5 Communication Overview

External communications to the BESS are through a Group Master interface. This interface supports the SCADA lines and also communications of status data from the Smart Grid Domain Controller (SGDC) to the utility’s EMS. Two Group Master Control channels are supported: a Primary Group Master (PGM) and an optional Secondary Group Master (SGM). However only

the Primary Group Master Control group is implemented in this BESS installation. The SGDC communicates internally with the Battery, PCS, and other equipment that is assigned to the relevant group to implement the commands from the Group Master.

The SGDC supports DNP3 protocol for its control interface.

The Wailea application has one control group. The master command sources will be assigned as follows, using the DNP3 connections:

PGM → MECO EMS

6.1.7.6 SGDC Control Modes

The following modes are currently supported by BESS:

- **Shutdown:** The control group disconnects all PCS contactors and all Grid Battery Storage Systems (GBSS) from the DC bus. Real and reactive demand for the group are both set to zero. When the BESS is in shutdown mode, the group can only be set to another mode through the Human Machine Interface (HMI).
- **Manual:** Real and reactive demand for the control group is set locally using the HMI. When in manual mode, the group can only be set to another mode from the web HMI.
- **Dispatch:** The control group follows the control signals for both real and reactive power from a group master. If the PGM signals are provided, the control group follows the signal of the State of Charge Management (SOCM) controller. If PGM signals are not received, the State of Charge (SOC) is maintained at the last value received for PGM and SGM.
- **Voltage support mode:** Reactive power follows the signal of the voltage support controller to support voltage at the point of measurement. Reactive power control will continue even if there are no commands from the PGM. Real power can be specified from a group master using the EMS; however, this can limit the reactive power available for the voltage support controller. As with the dispatch mode, if the PGM signals are not provided, the control group follows the signal of the SOCM controller. The SOC is maintained at the value that it was at the time of the last command from the PGM.
- **Idle:** Real power is controlled to keep the batteries' SOC constant at the commanded level. If PGM not provided, the SOC is maintained at the last commanded level.
- **Load smoothing/Peak shaving:** In this mode, BESS charging/discharging is controlled by the difference between a desired load setpoint and the load flowing to the circuit. In other words, if the load is higher than the setpoint, BESS is discharged to keep the transformer load level and vice versa. BESS charging continues up to fully charged state which has SOC of almost 95%.

6.1.7.7 BESS Operating and Analysis Plan

Three types of test/operations using BESS were performed:

- **System Impact Tests:** One of MECO's fundamental project objectives was to see how the system (transmission, substation and distribution) would react to charge and discharge of the battery. Therefore, the first tests were a series of "injections" (battery discharging) and "absorptions" or load increases (battery charging) of real and reactive power. Different levels of charge and discharge were observed, covering the range of BESS capacity:

- Active/Real Power Absorption (battery charging)
- Active/Real Power Injection (battery discharging)
- Reactive/VAR Power Absorption (battery charging)
- Reactive/VAR Power Injection (battery discharging)
- **BESS Efficiency Test:** measuring the round trip efficiency (RTE) of a BESS charge/discharge cycle
- **Peak Load Reduction and Load Following:**
 - The BESS has a load following capability, where it will charge and discharge as necessary to maintain feeder load (as measured at the substation transformer) at a designated (i.e., target) level
 - This capability can be used for Load Smoothing, compensating for variability in renewable energy output (PV panels) and loads
 - Activating this operating mode during feeder or system peak enables the BESS to minimize the peak load (or system coincident peak load) of the feeder
 - A series tests were conducted that operated BESS to achieve combined Peak Shaving and Load Smoothing (PS/LS) objectives

6.1.8 Distribution Management System (DMS)

The project developed and installed a distribution management system (DMS) that included distribution SCADA, load flow model, IVVC modeling, and outage reporting. Additional interfaces were developed to integrate data from the AMI and DR systems installed in the Maui Meadows area. In addition, current sensors were strategically placed along the feeders and reported distribution line currents to the DMS.

Data collection and testing of the DMS provided MECO with the following information and capabilities:

- Additional visibility into distribution system status and operations;
- Visualization of voltage violations and outage reports;
- Load flow model validation with real-time operational data; and
- Monitoring and coordinated operation of DER, including demand response, distributed generation, and BESS.

The following table presents a summary of the DMS- and DA-related questions, sources of information to address the questions, and a summary of the analysis.

Distribution Management System / Distribution Automation

Area of Interest	Key Research Question	Test / Evaluation Methods	Metrics	Data Required	Project Objective
Aggregate DER	<ol style="list-style-type: none"> Can different DER (DR, storage, VVC) be compared and evaluated to most effectively reduce feeder or system loading? Can DER be managed as a group resource (instead of local optimization of dispatch of each type of DER) 	<ol style="list-style-type: none"> Develop a standard DER resource representation/model (for BESS, DR, VVC, distributed renewable energy) Provide dashboard display to MECO operations Extrapolate Maui Meadows DER to estimated MECO system DER Display available load reduction and costs from each DER source. Operator dispatches DER 	<ol style="list-style-type: none"> Load reduction possible Anecdotal – how often does system operator use this. Record incidents (and details) where DER was dispatched as a total group or where a non-traditional DER was used (e.g., DR instead of BESS; BESS or DR instead of VVC using LTC) 	<ol style="list-style-type: none"> Available BESS, available DR, load change possible from LTC or capacitors Model of DR and BESS to determine available load reduction and persistence Record DER capacity and energy availability during test period Extrapolate Maui Meadows DER available to estimated MECO system DER available Record information when DER were dispatched 	<p>D-1: Reduce Peak Load T-1: Integrate Transmission level RE T-3: Reduce Transmission Congestion D-4: Integrate DER</p>
Volt/VAR Control	Will having the DMS and AMI enable tighter adherence to service voltage limits?	Compare standard LTC settings (and resulting voltage) with LTC settings (and resulting voltage profile) possible with feeder monitoring and modeling	<ol style="list-style-type: none"> Reduced out-of limit voltage excursions Closer adherence to nominal service voltage 	<ol style="list-style-type: none"> Voltage profile and feeder load using standard LTC setting Voltage profile and feeder load using DMS-suggested LTC setting 	<p>D-1: Reduce Peak Load D-2: Improve Service Quality D-4: Integrate DER</p>
Validate distribution feeder load flow model	Will the validated real-time feeder model enable MECO to better keep within voltage limits AND reduce system load	<ol style="list-style-type: none"> Using the feeder model, compare the feeder voltage profile (actual) with the estimated feeder voltages, and determine if it is possible to reduce voltage (LTC) and stay within limits, compared to previous guidelines the voltage needs to be increased (LTC) to prevent low voltage VVC will make recommendations for operator action. Protocol will implement recommendations and see if results match prediction 	<ol style="list-style-type: none"> LTC setting using current guidelines LTC setting using DMS 3 of out of range voltage incidents avoided Load reduction (kW & kWh) possible with more precise LTC management 	<ol style="list-style-type: none"> Line voltages Line currents Historical feeder voltage profiles (after installation of meters but before controls) System load measurements 	<p>D-1: Reduce Peak Load D-2: Improve Service Quality D-4: Integrate DER (VVC, DMS, AMI)</p>
Monitor / report	When and where do under/overvoltage	Evaluation of voltage events by duration and location	Voltage readings at substation and at	<ol style="list-style-type: none"> Meter voltage readings 	D-2: Improve Service Quality

Distribution Management System / Distribution Automation					
Area of Interest	Key Research Question	Test / Evaluation Methods	Metrics	Data Required	Project Objective
voltage violations	events occur	Will the DMS (with AMI) more accurately predict voltage excursions?	customer meters 1. Number of voltage excursions 1) the occur, or 2) that would occur without DMS-suggested LTC change 2. Number of voltage excursions predicted using old methods	2. Substation voltage reading 3. Predicted voltage excursions using previous estimation techniques	D-4: Integrate DER
Peak Load Reduction	How much can DER reduce feeder/substation and system peak?	Dispatch (“SCRAM”) DER – BESS, DR, VVC – at selected times to measure aggregate load reduction possible.	kW and % reduction in load	1. Available DER (from dashboard) 2. System, substation, and feeder loads before, immediately after, during, and at termination of SCRAM command	D-1: Reduce Peak Load T-3: Reduce Transmission Congestion
Outage reporting	Difference in time an outage is reported through metering system to the DMS versus through the customer service lines	Anecdotal, if there are outage incidents in Maui Meadows	Outage notification / identification notification timeline	1. Meter last Gasp message 2. Message reception time at customer service	D-2: Improve Service Quality
Reserve Support	Can managing DER reduce the amount of fossil-fueled operating reserves needed to support as-available renewable energy?	1. Provide estimate of available DER (DR, BESS, IVVC). 2. Provide estimate of Maui Meadows PV output versus nameplate, and also extrapolate to MECO system. Determine if operating reserve requirement can be reduced. 3. Develop PV output variability data base to better determine reserve requirements to support distributed PV	Amount of fast response operating reserve DER can provide.	Maui Meadows PV output (with some time-averaging, to compensate for variability of local Maui Meadows site versus island-wide variability)	D-4: Integrate DER T-1: Integrate Transmission level RE T-2: Provide Ancillary Services

Figure 6-12: Distribution Management System (DMS) / Distribution Automation

6.2 Experimental Results

6.2.1 Demand Response

The system performance period of 12 months was divided into two periods:

- Data gathering and model building – baseline (months 1 – 6).
 - Build/verify baseline appliance load profiles
 - Analyze eGauge data to develop DR dispatch schedules
- Data gathering and model building – DR dispatch (months 7 – 12).
 - Initiate DR commands to update load reduction and payback models for DR dispatch.
 - Observe the results of DR dispatch for peak reduction and for increasing minimum (nighttime) load.

During the performance period the DR loads were controlled as follows:

- A/C thermostats were raised by 3 degrees for 60 minutes from 1500 – 1600 hours.
- WH were disabled for 60 minutes from 1900-2000 hours.
- The hours for initial control periods were based on:
 - Times of system and feeder peak
 - Times of high diversified appliance load (i.e., when is there significant amount of load to control?)
- Towards the end of the performance testing, the WH control will be extended from 1900 to 0300 hours, in an attempt to see if it is possible to increase WH loads during late night (when wind would otherwise be shed) without affecting customer service.
- Whole house and feeder/system data will continue to be recorded.
- Appliance loads were observed from eGauge loggers to evaluate response to DR commands.

Figure 6-13 shows for one participant the house (solid line) and A/C (dashed line) loads recorded by eGauge equipment when the thermostat setpoint was raised by 3 degrees from 3 to 4 PM.

After the project, MECO will use the observed DR response to help estimate potential DR on the MECO system by time of day (based on MECO appliance saturation and extrapolated for the feeder and/or for the MECO system).

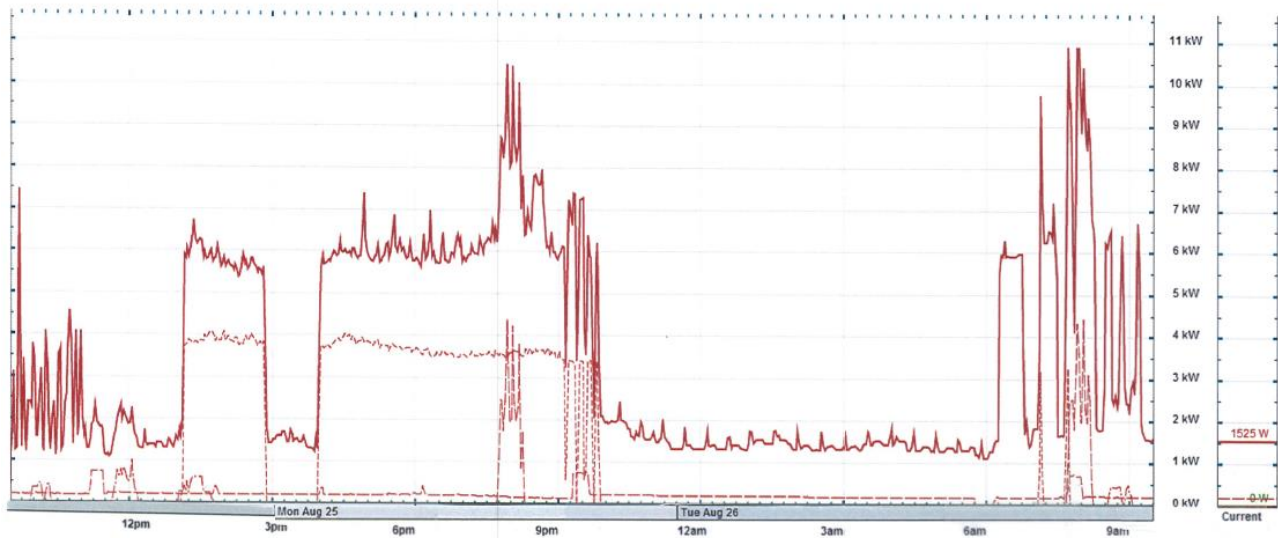

Figure 6-13: Exercise of DR: raising A/C thermostat 3 degrees from 3 to 4 PM

Of the 88 volunteer participants, 15 homes agreed to implement WH load control, and 5 A/C units had adjustable thermostats. With such small numbers of DR volunteers, it was not possible to obtain statistically significant data on the load impacts and the customer acceptance of the DR strategies. However, information was obtained from:

- The SSN UIQ system, which indicated when load control devices successfully received and executed DR commands;
- eGauge monitors showing 1 minute interval data of five selected homes and appliances;
- AIM meters, showing total household load (15-minute interval); and
- Interviews with participants about their experience with the project, including DR.

Those observations suggest:

- Residential A/C may offer less of a DR resource during the day than expected. The load data showed that a significant number of Maui Meadows residents keep their A/C off for most of the day, turning it on in the afternoon and evening (presumably after most of the residents had returned from work or school).
- Raising the thermostat 3 degrees F for one hour is probably an acceptable residential DR control strategy. The UIQ system indicated that one A/C load control participant overrode the higher thermostat setting once during the test period (and that was 3 minutes before the 1-hour control period ended).
- Control of WH for an hour in “SCRAM” mode can likely mitigate sudden drops in as-available renewable energy generation, or loss of other MECO generation. HECO has used WH control to provide immediate short-term load reduction to address operations issues. The Maui Smart Grid project indicates that DR from WH would be a valuable resource for MECO to use in the same manner. However, MECO should conduct a residential WH load research study, because the amount of curtailable WH load by time of day is probably significantly less than for mainland utilities.
- Control of WH for 1 hour is probably an acceptable residential DR strategy. Consistent with other utilities’ reported DR programs for WH, the storage capacity of the typical

WH tank is usually more than adequate to bridge 4 to 6 hour OFF time commands. There were no complaints of cold water from any of the Maui Meadows DR volunteers.

- Turning off the WH from 7 PM to 2 or 3 AM is probably acceptable, and offers the potential to increase minimum MECO system load (and thus reduce wind curtailment). The eGauge monitors suggest that large household energy use after 8 or 9 PM may be due to dishwashers, WH after showers, and A/C (until the outside temperature cools sufficiently). For the last week of the test period, all WH were turned off from 9 PM to 2 AM; no customers complained. (We believe that the customers did not notice.)
- MECO should investigate the feasibility of a program to encourage residences to delay evening dish washer operations until the time of MECO minimum system load. The eGauge monitors showed dishwashers operating after dinner. Turning off the WH would enable the dishwasher to use the stored hot water in the tank, but defer the load needed to replace that hot water. However, the dishwasher heating element is another significant late evening / early night load. It is recommended that MECO investigate the feasibility of ways – either technology-based or customer education / motivation – to defer evening dishwasher use. Most dishwashers have an option to delay the start of operations for 2, 4, or 6 hours. If the dishwasher could be controlled to schedule its operation for late night, or if the consumer could be motivated to select the “DELAY” button to defer dishwasher operation, both the dishwasher’s heating element and hot water loads could be deferred until the time of MECO’s minimum load. Such a feasibility assessment will also have to consider the possibility that noise from late night dishwasher operation might disturb the residents.

6.2.2 Residential Home and PV Load Profiles

6.2.2.1 Home Energy Use Profiles

The 87 residential participants consisted of three groups:

- Group 1: homes without PV (54 customers)
- Group 2: homes with PV; PV was separately metered (6 customers)
- Group 3: homes with PV; PV was not metered (17 homes)

Figure 6-14 shows the total energy use load profile for each group. The group with PV meters has significantly higher energy consumption than the other two groups. The project team investigated this and found that two of the homes (of the group of 6) had large loads not typical of the average Maui Meadows resident. (These were a workshop and an in-home business that both included many high demand electrical appliances.) Because there were only 6 homes in this group, the two unusual cases biased the data for the entire group. Figure 6-15 shows the normalized load shape of each group; all exhibited very similar usage profiles.

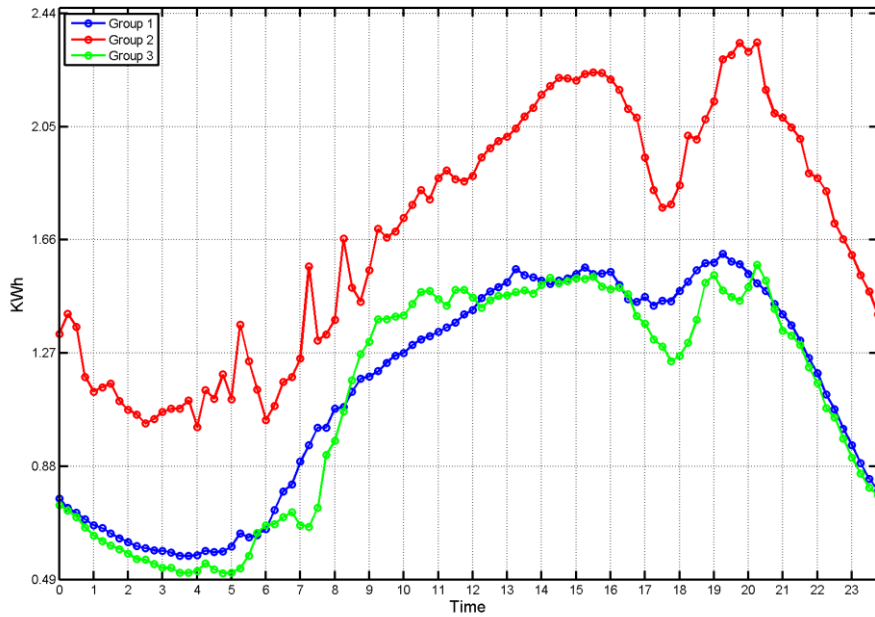

Figure 6-14: Average daily load profile for participant homes by group

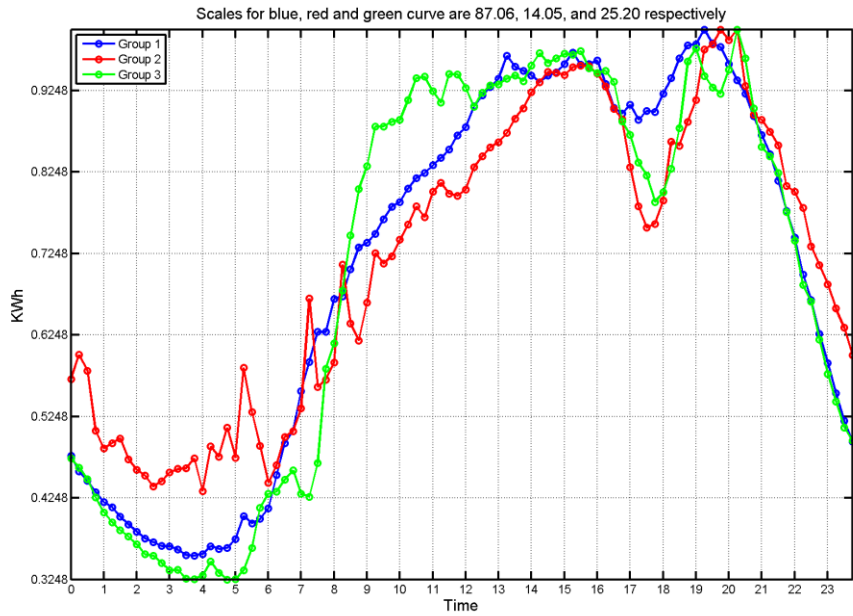

Figure 6-15: Normalized daily load profile for participant homes by group

Figure 6-16 shows the average weekly load profile for the 54 homes in Group 1. It is notable that the shape and magnitude of the total house energy use profile does not vary significantly by day of week or weekday/weekend.

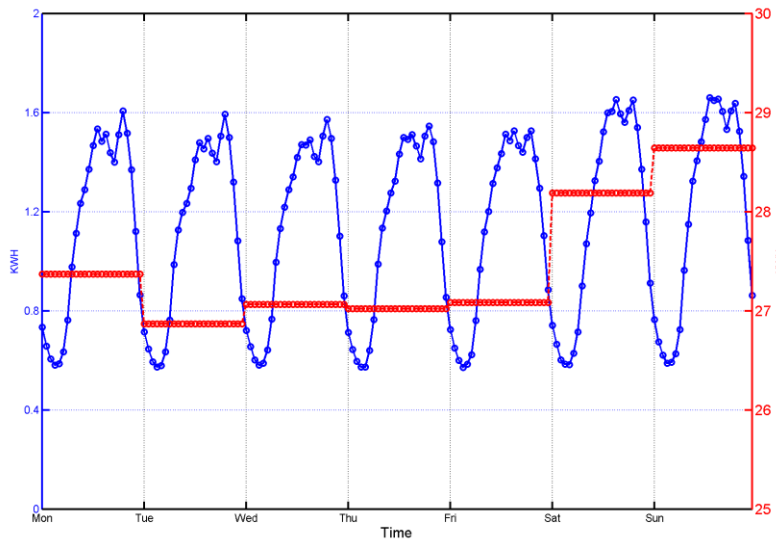

Figure 6-16: Average weekly household load profile for participant homes in group 1

6.2.2.2 Voltage Monitoring

Traditionally, distribution feeders, especially residential feeders, are modeled with a static load flow program whose inputs include estimates of loads of each pole-top or pad mount transformer (based on transformer nameplate capacity, as a fraction of the total nameplate capacity of all transformers on the feeder, and then weighted by the feeder load shape – by time of day – as measured at the substation) and the electrical characteristics of all conductors, capacitors, and other devices on the feeder. The assumption is that the voltage is highest near the substation, decreasing farther out on the feeder, and being boosted by capacitors when the voltage comes close to the lower point of its acceptable operating range.

A primary objective of this project was to increase MECO’s visibility into its distribution system. The installed AMI energy meters also record voltage at the customer’s premises. Figure 6-17 shows the out of range voltages detected early in the project, soon after the smart meters were installed. Instances of high and low voltages were not limited to the “beginning” or “ends” of the feeder. MECO found that several distribution transformer taps had to be adjusted. Once this was done, MECO observed many fewer out of limit voltages.

However, it became apparent that the high penetration of distributed PV was resulting in quite different feeder current and voltage patterns than had been observed in the past. MECO is continuing to use the project data and the load flow model (and volt/var application) from the DMS to develop guidelines for voltage management with high penetration PV. Other MECO/HECO projects have already implemented distribution system monitoring with higher sample rates to address this issue:

- MECO’s Maui Advanced Solar Initiative (MASI) project; and
- HECO’s DVI project on Oahu.

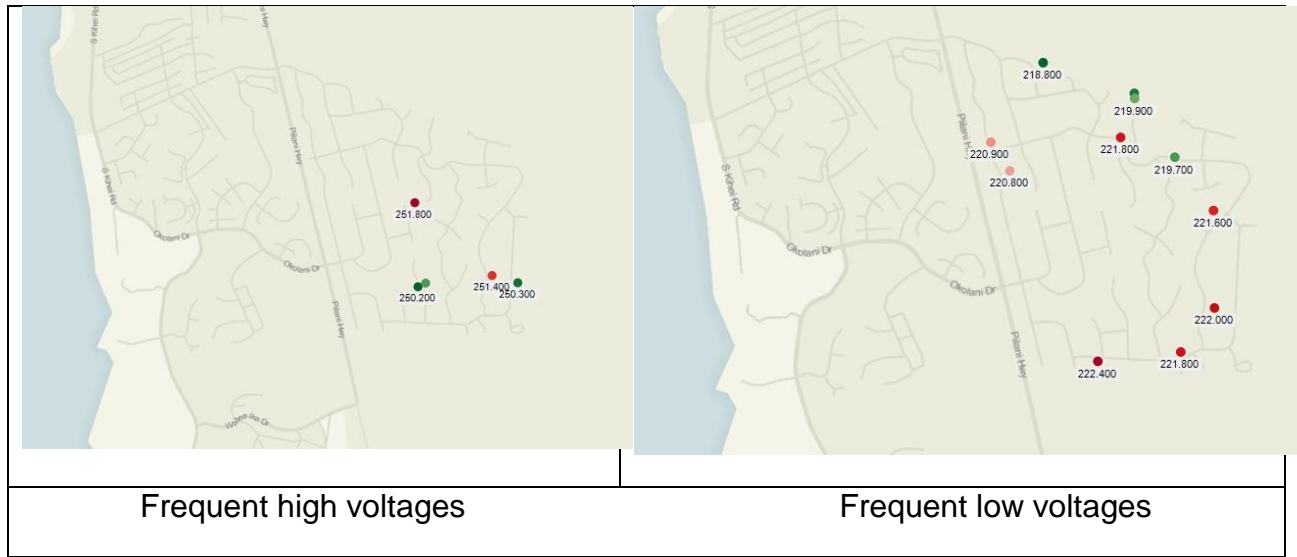

Figure 6-17: Observed out of limit voltages on Feeder 1517

6.2.2.3 PV Generation Profiles

The seven metered PV panels showed similar power generation profiles (Figure 6-18). (Seven homes had PV panels metered, but one did not have a “smart” meter for its household energy consumption; consequently, it could not be used in the calculation of residential energy use profiles above.)

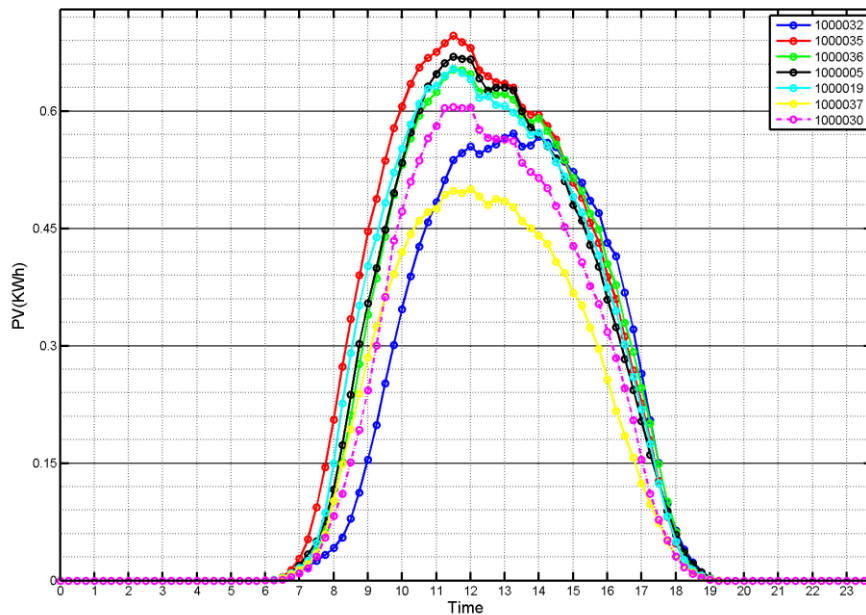

Figure 6-18: Profile of average output for 7 PV panels (normalized to PV panel rating)

Figure 6-19 shows the PV panels’ outputs were well correlated with the irradiance reading of the pyranometer in the Wailea substation. Determining the actual amount of PV generation on its system is a major priority for MECO. This experiment demonstrated that MECO can obtain that

real-time information using pyranometers placed in substations and monitored by the SCADA system; frequent remote meter reading of PV panels is not required.

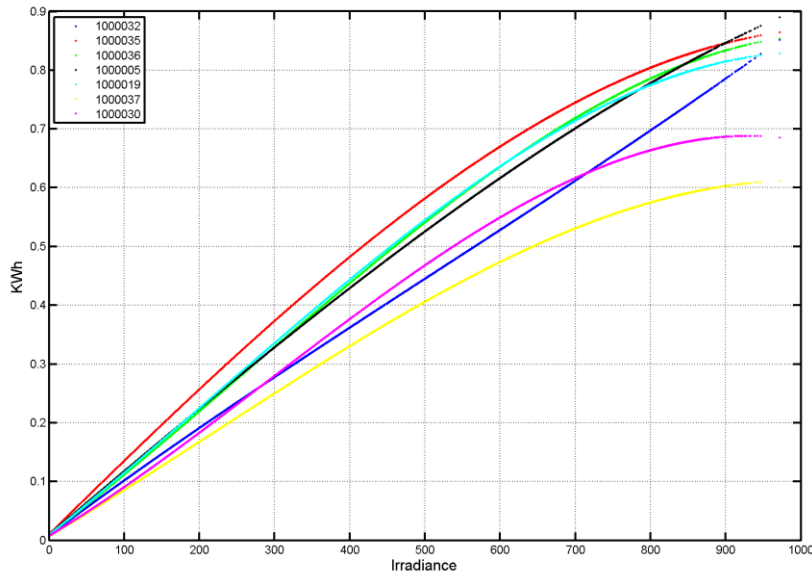

Figure 6-19: Correlation of PV panel output and substation irradiance sensor (pyranometer)

6.2.3 Customer Energy Use and Web Portal Usage

6.2.3.1 Energy Usage

Home volunteers were able to obtain near real time energy use information through their online web portals that were installed when they received their smart meters. The near real time energy use data that they could access allowed volunteers to more actively manage their daily energy use. Monthly energy use data (kWh) was collected for each participant the year before (Year 1: August 2011 – July 2012) and after (Year 2: August 2012 – July 2013) home volunteers received their smart meters. For non-volunteers who lived in the same geographic area, energy use data was collected for the year after the project started (Year 2: August 2012 – July 2013).

MSGP Volunteers Energy Use

Energy usage data was collected for all participants who volunteered for the MSGP. All volunteers received smart meters and online web portals to track their energy use. Data included Year 1 and Year 2. Overall, there was a downward trend in energy usage. In Year 1, the average monthly usage was 754 kWh. In Year 2, it was 582 kWh, a 23% decrease from Year 1 (Figure 6-20).

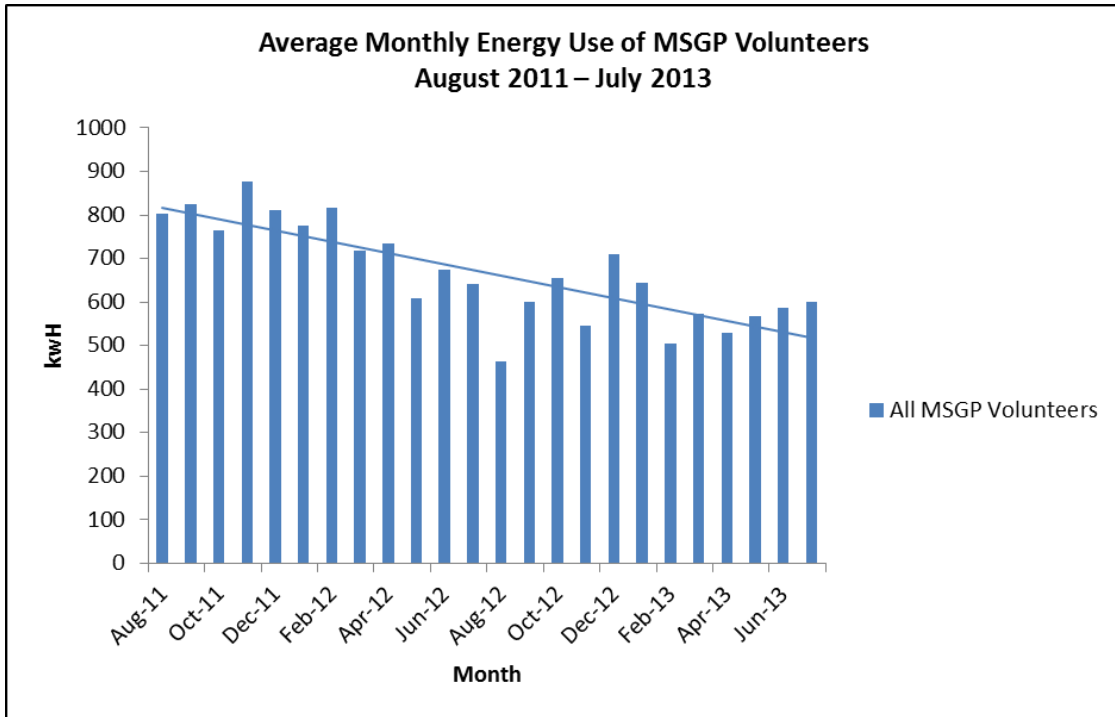

Figure 6-20: Average Monthly Energy Use of Volunteers, August 2011 to July 2013

Volunteers vs. Non-Volunteers

Energy data from a general sample of non-volunteers represents participants who live in the same neighborhood and did not have access to the smart meter tools (e.g., online web portals, in-home devices, and/or student audits). Figure 6-21 shows the energy use of MSGP home volunteers and non-volunteers one year after the project began. The energy use of non-volunteers was much higher and more variable than the MSGP volunteers.

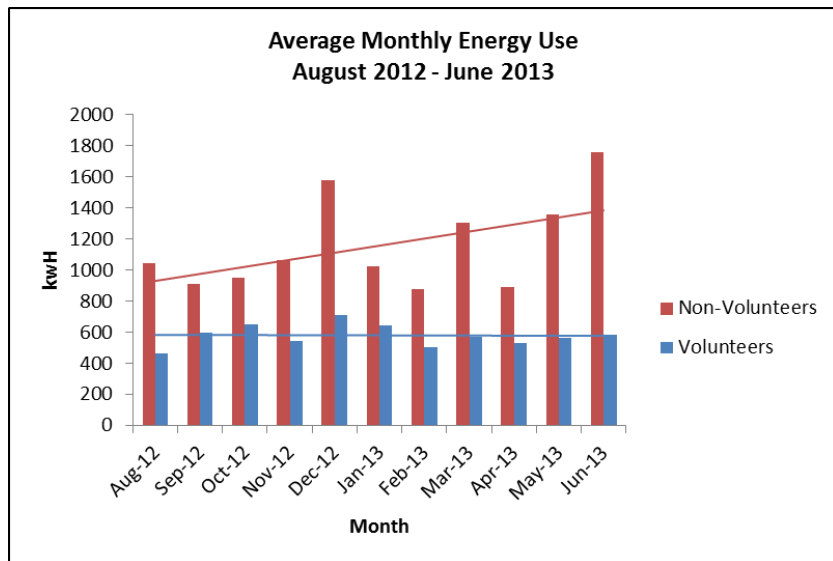

Figure 6-21: Average Monthly Energy Use of Volunteers and Non-Volunteers, August 2012 – June 2013

Volunteer Photovoltaic (PV) Users vs. Non-Volunteer PV Users

Since the use of PV panels can significantly affect the amount of recorded energy usage, the MSGP volunteers and the non-volunteers were classified based on those who had PV panels on their homes and those who did not. The volunteer PV sample included 19 homes and represented residents who received a home energy audit and those who did not. The non-volunteer PV sample included 93 homes.

Figure 6-22 shows the energy use of volunteer PV users compared to non-volunteer PV users. Volunteer PV users had lower average monthly energy use than non-volunteer PV users. The average annual energy use for volunteers was 220 kWh, compared to 643 kWh for the non-volunteers between 2012 and 2013, a difference of 423 kWh. Both groups had a lot of variation in their energy use throughout the year, which could possibly be attributed to PV installation dates, which were unavailable.

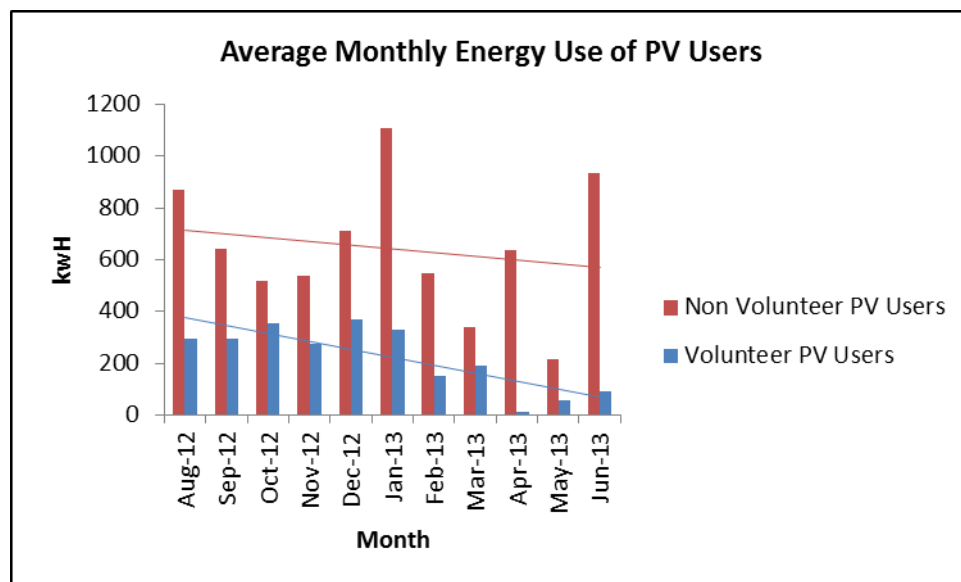

Figure 6-22: Monthly Average Energy Use for Volunteer PV Users vs. Non-Volunteer PV Users

Volunteer Non-PV Users vs. Non-Volunteer Non-PV Users

Many residents in the project subdivision did not have PV installed; therefore the non-PV users were also compared (see Figure 6-23). Volunteer non-PV users had lower monthly energy use compared to non-volunteer non-PV users. Average monthly energy use for volunteer non-PV users was 726 kWh, and 1161 kWh for the non-volunteers, a difference of 435 kWh or 46%. Overall, both groups had upward trends in energy use over the year.

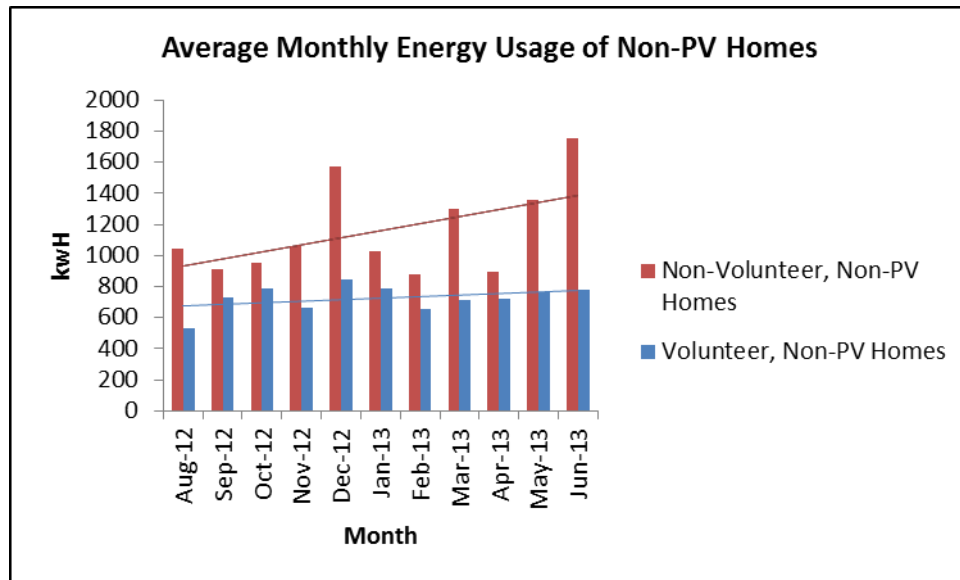

Figure 6-23: Monthly Energy Use for Volunteer, Non-PV users vs. Non-Volunteer, Non-PV users

Home Energy Use for Homes that Received Energy Audits

Figure 6-24 shows the average monthly energy use for volunteers who received a home energy audit in Year 1. The sample size included 24 home volunteers, including 9 who had PV. The average monthly energy use between August 2011 and July 2012 was 844 kWh. For Year 1, home energy use had an overall decline for homes that received energy audits.

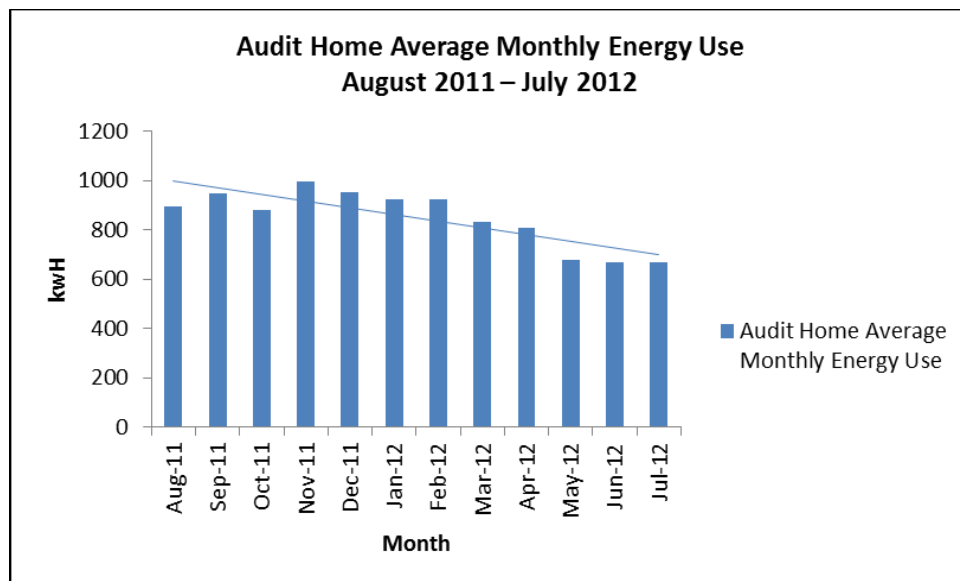

Figure 6-24: Average Monthly Energy Use of Audit Homes Year 1: August 2011 to July 2012

The average monthly energy use continued to decline after the equipment installation. Average monthly energy use was 528 kWh for Year 2, a decrease of 37% from Year 1 to Year 2. Figure 6-25 shows the combined average monthly energy use of audit home volunteers for Years 1 and 2, which shows an overall decline of 37%.

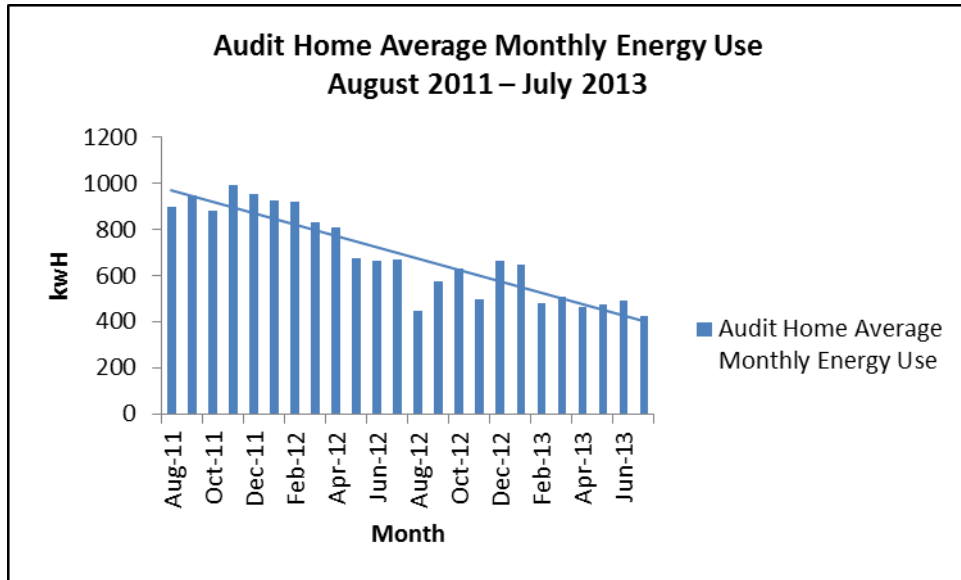

Figure 6-25: Average Monthly Energy Use of Audit Homes Years 1 and 2: August 2011 to July 2013

Non-Energy Audit Energy Use

Average monthly energy use for home volunteers who did not receive a home energy audit in Year 1 included 26 homes, 9 of which had PV panels installed. From August 2011 to July 2012, the average monthly energy use was 672 kWh and showed a slight overall decrease over the year. (see Figure 6-26). Following the equipment installation, in Year 2, average annual energy use only decreased slightly to 632 kWh, a decrease of 6% from Year 1. (see Figures 6-27 and 6-28).

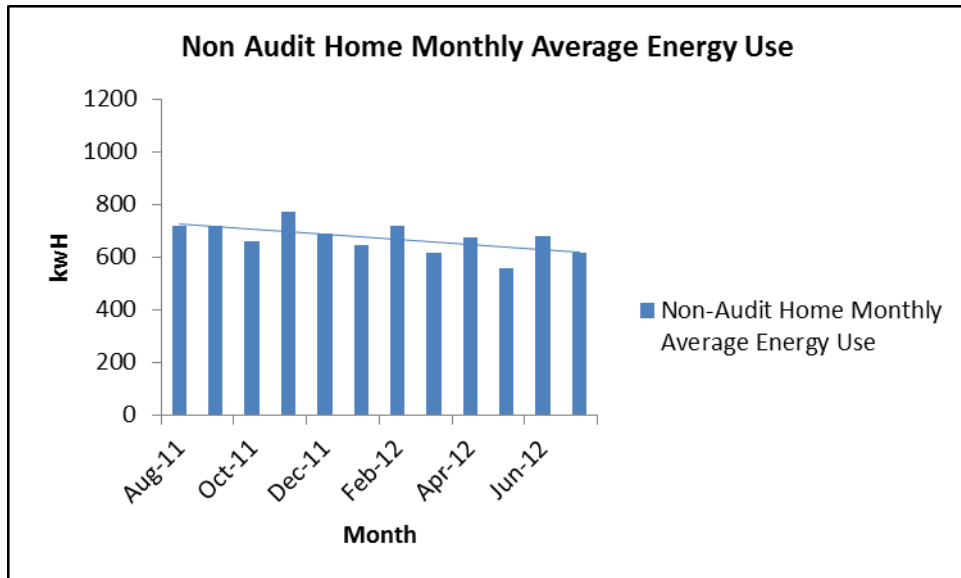

Figure 6-26: Average Monthly Energy Use of Non-Audit Homes Year 1: August 2011 to July 2012

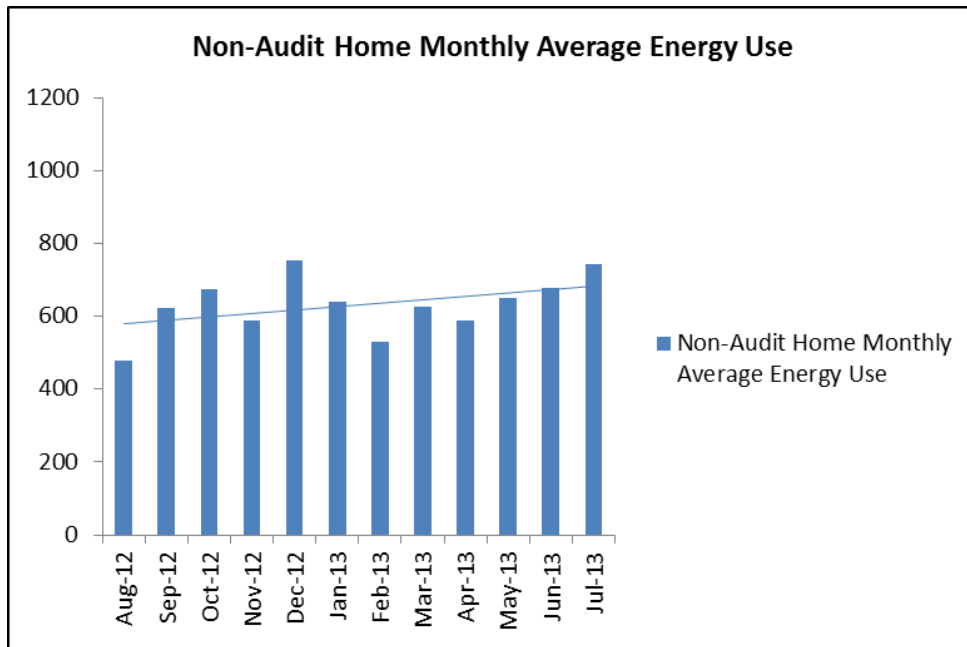

Figure 6-27: Average Monthly Energy Use of Non-Audit Homes Year 2: August 2012 to July 2013

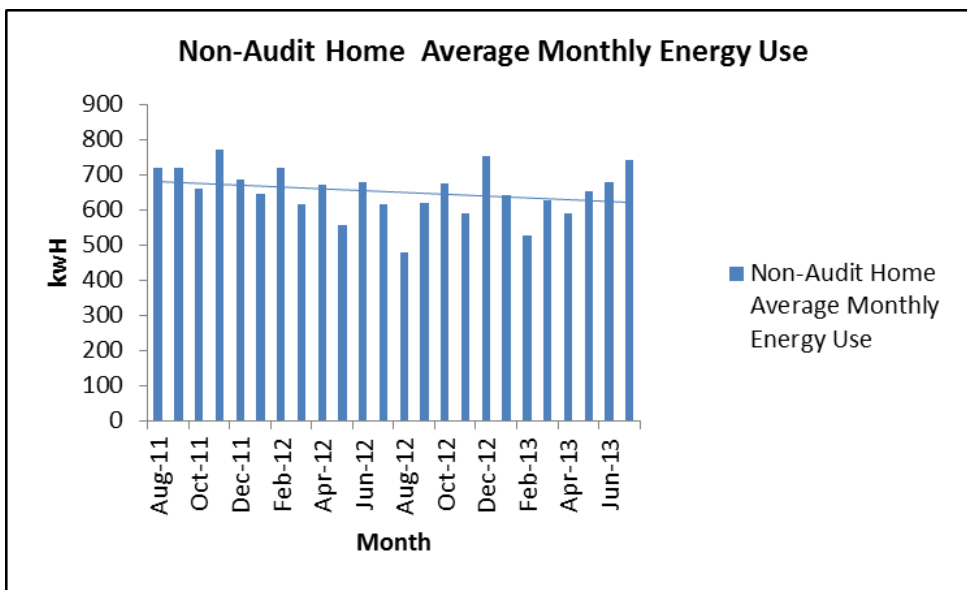

Figure 6-28: Average Monthly Energy Use of Non-Audit Homes Years 1 & 2: Aug. 2011 – July 2013

Energy Audit vs. Non-Energy Audit Energy Use

Figure 6-29 shows the difference between average monthly energy use of home volunteers who received home energy audits and home volunteers who did not receive home energy audits in Years 1 and 2. The average annual energy use for home volunteers who received an energy audit decreased from 844 kWh in Year 1 to 528 kWh in Year 2, an average annual decrease of 37%. Annual average energy use for home volunteers who did not receive a home energy audit decreased only slightly, from 672 kWh for August 2011 – July 2012 to 632 kWh for August 2012 – July 2013, an average decrease of 6%.

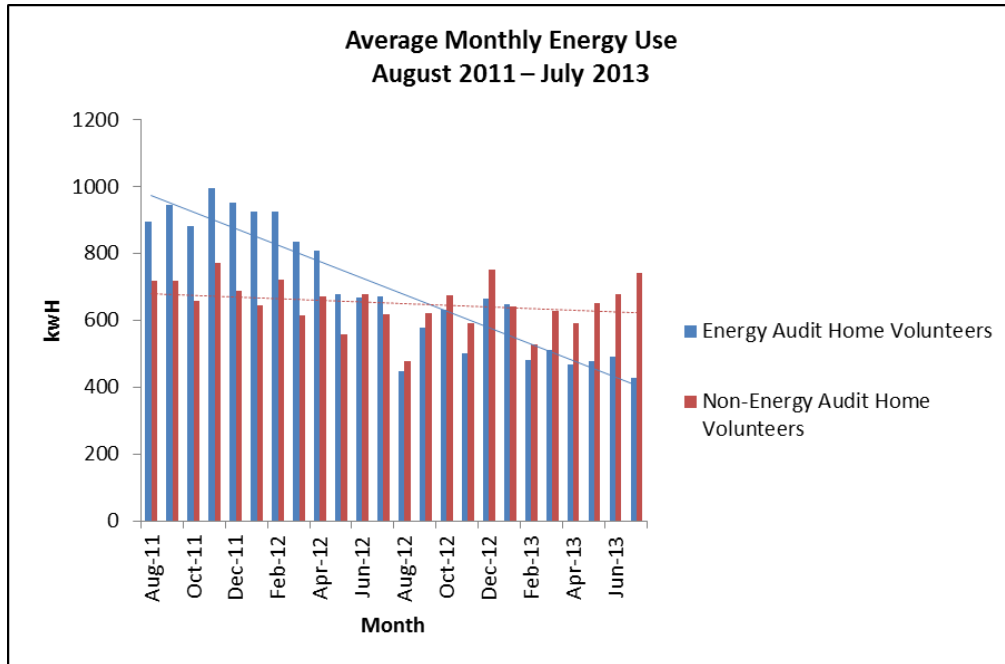

Figure 6-29: Monthly Average Energy Use for Energy Audit Homes vs. Non-Energy Audit Homes, Years 1 and 2: August 2011 to July 2013

IHD Users vs. Web Portal Users Energy Use

The average monthly energy use of volunteers who received an IHD and those who did not are shown in Figure 6-30 for Year 1 (August 2011-July 2012: the year before the equipment was installed). Volunteers who elected to receive an IHD display had 35% higher average monthly energy use (853 kWh) than volunteers who did not elect to receive an IHD (630 kWh).

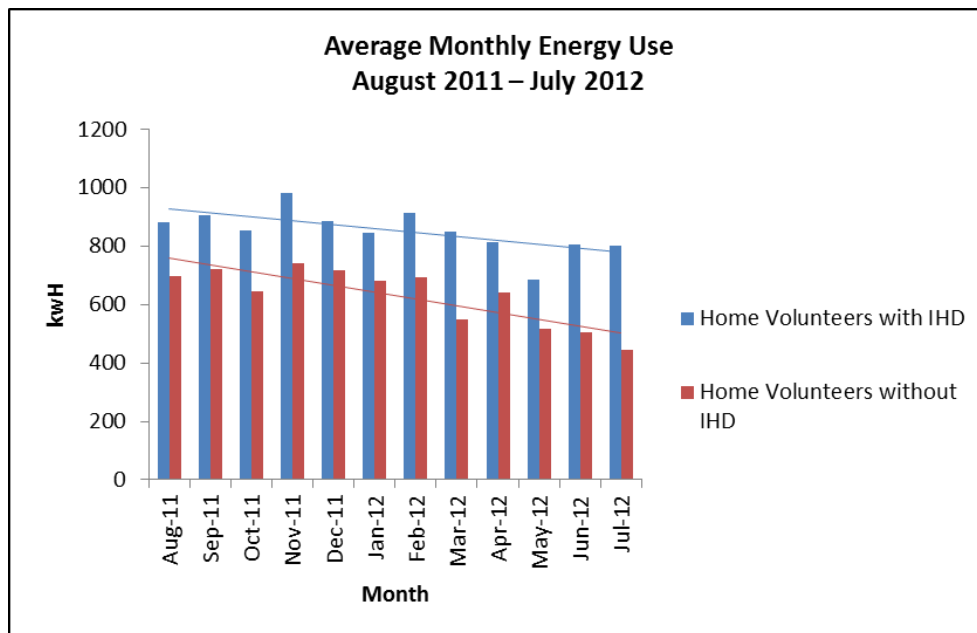

Figure 6-30: Average Monthly Energy Use of IHD and Non-IHD Volunteers Year 1: August 2011-July 2012

Figure 6-31 shows the energy use of home volunteers with an IHD and home volunteers without an IHD during the project and after the IHD installation. Home volunteers without an IHD used less overall energy than home volunteers with an IHD installed. The average annual energy used from August 2012 to July 2013 for home volunteers without an IHD was 449 kWh. The average annual energy used during the same time period for home volunteers with an IHD was 679 kWh. Home volunteers without an IHD had 34% lower energy use than home volunteers with IHDs.

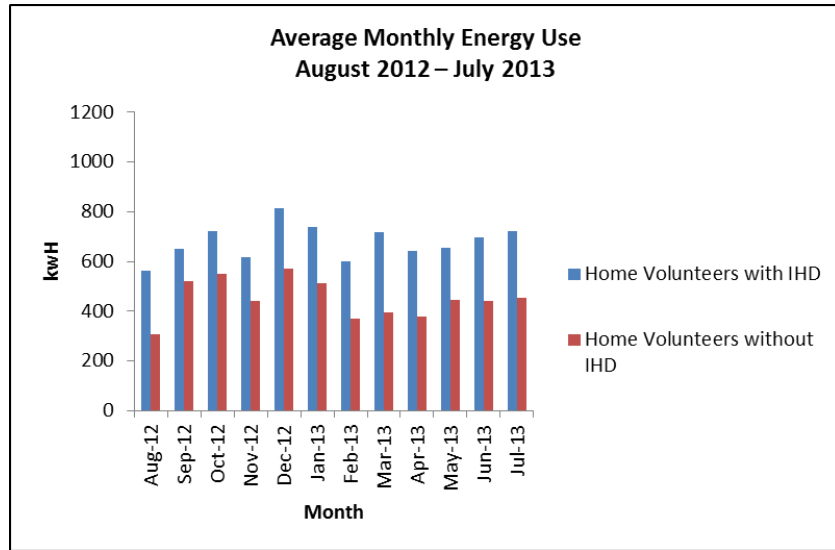

Figure 6-31: Average Monthly Energy Use of IHD and non-IHD Volunteers Year 2: August 2012- July 2013

Figure 6-32 shows the total average monthly energy use of home volunteers with an IHD and home volunteers without an IHD for Years 1 and 2. Overall, the average annual energy use for both IHD and non-IHD volunteers decreased. Home volunteers with an IHD had decreased energy use from 853 kWh to 679 kWh (20%). Home volunteers without an IHD had energy use that decreased from 630 kWh to 449 kWh (29%).

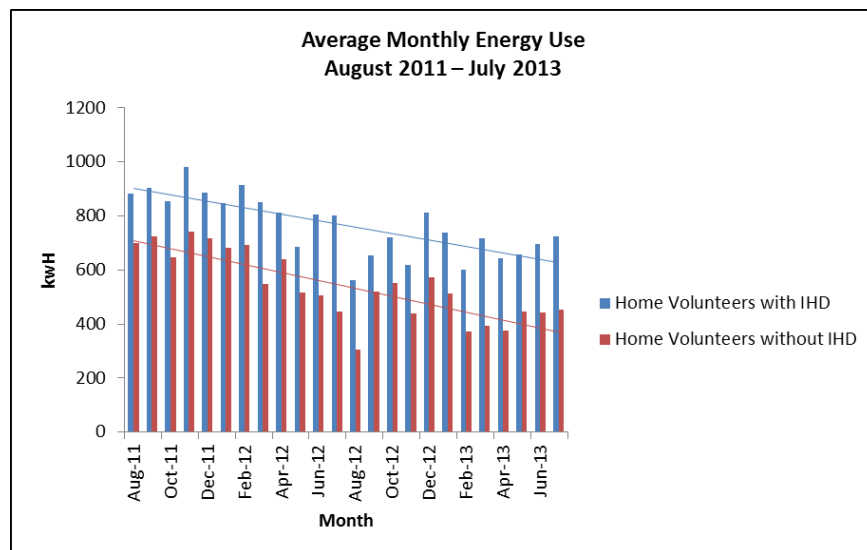

Figure 6-32: Average Monthly Energy Use of IHD and non-IHD Volunteers August 2011 – July 2013

IHD Comparison between Energy Audit and Non-Energy Audit Home Volunteers

IHD users were also assessed based on whether they received an energy audit or not. Figures 6-33 and 6-34 show the average monthly energy use of participants with and without an IHD and without an energy audit. Overall, volunteers who had an IHD and had an energy audit decreased by 28% more than volunteers who had an IHD and did not receive an energy audit. Also, volunteers who did not have an IHD but did have an energy audit decreased 44% more than volunteers who did not have an IHD or an energy audit.

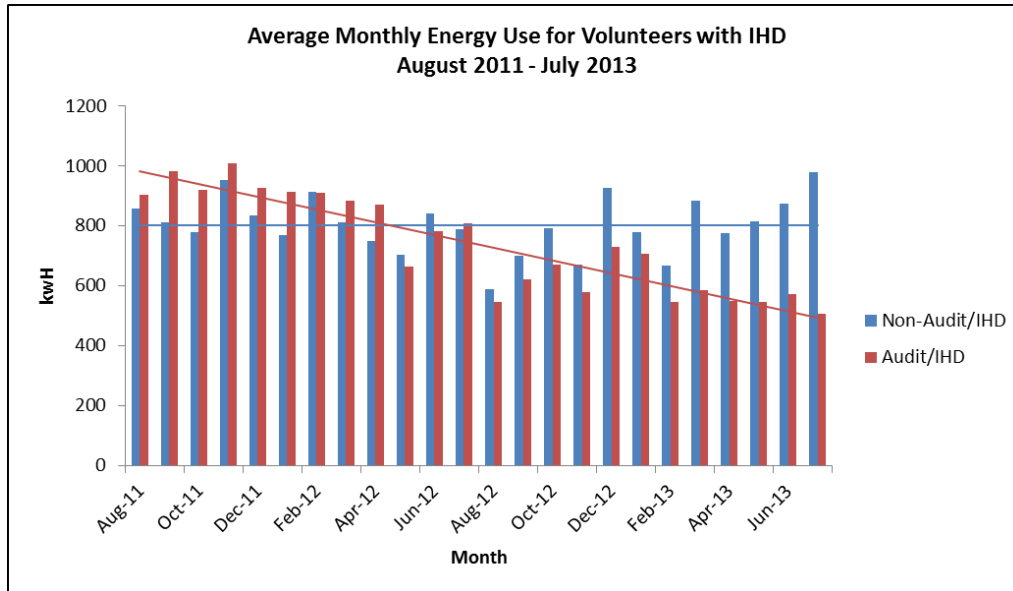

Figure 6-33: Average Monthly Energy Use of Audit Home Volunteers and Non-Audit Home Volunteers who are IHD Users

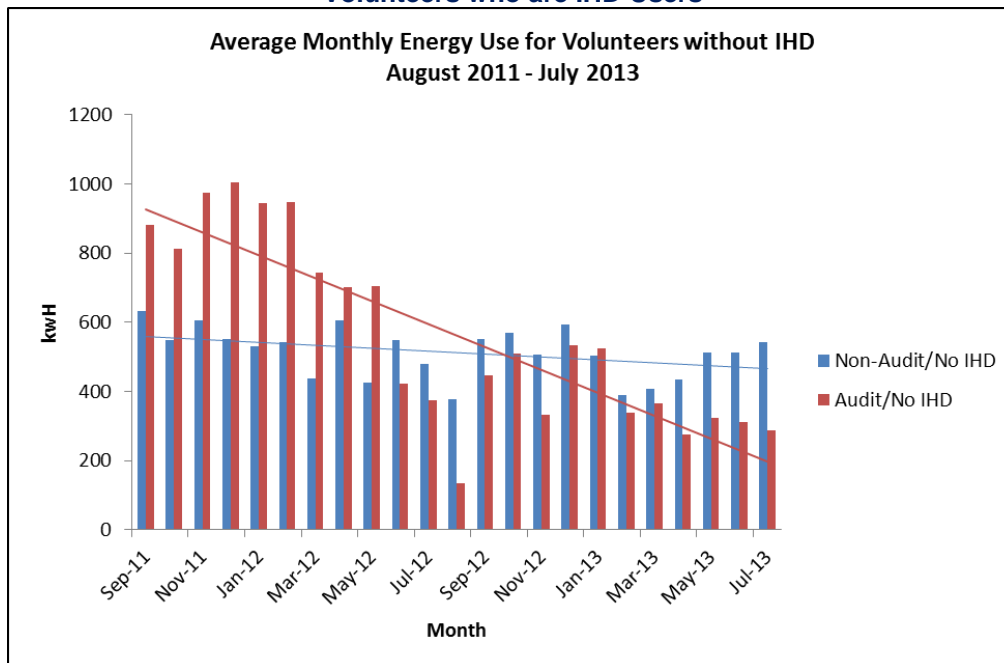

Figure 6-34: Average Monthly Energy Use of Audit Home Volunteers and Non-Audit Home Volunteers who are not IHD Users

Energy Use Summary

Figure 6-35 shows the average annual energy use in kWh for Years 1 and 2 for volunteers in the MSGP. The percent changes for Years 1 and 2 are also shown.

	Year 1 Annual Average Energy Use (kWh)	Year 2 Annual Average Energy Use (kWh)	Percent Change
All Volunteers	754	582	-23%
Audit Home Volunteers	844	528	-37%
Non-Audit Home Volunteers	672	632	-6%
Volunteers with IHD	853	679	-20%
Volunteers without IHD	630	449	-29%
Audit Home Volunteers with IHD	881	597	-32%
Non-Audit Home Volunteers with IHD	819	788	-4%
Audit Home Volunteers without IHD	782	365	-53%
Non-Audit Home Volunteers without IHD	542	492	-9%

Figure 6-35: Energy Use Averages and Percent Change

6.2.3.2 Web Portal

Online web portals were installed in homes participating in the MSGP to help home volunteers obtain real-time feedback on their energy use. Every home volunteer received an online portal. Volunteers were asked in the surveys about their experience with the online web portals. Results indicated that volunteers were often confused about how to use it. Some comments from volunteers included, “I don’t think I have a smart meter,” “If I knew how I would use it,” “I haven’t tried it yet,” “Don’t know how,” “Have not taken the time yet.” Volunteers also indicated that they typically only used the portal at the beginning of the project (following installation of their smart meter). However, home volunteers who indicated that they knew how to use their portal were more likely to use it than home volunteers who said that they did not know how to use it. Figure 6-36 shows a comparison of online web portal use between volunteers who received an energy audit versus those who did not.

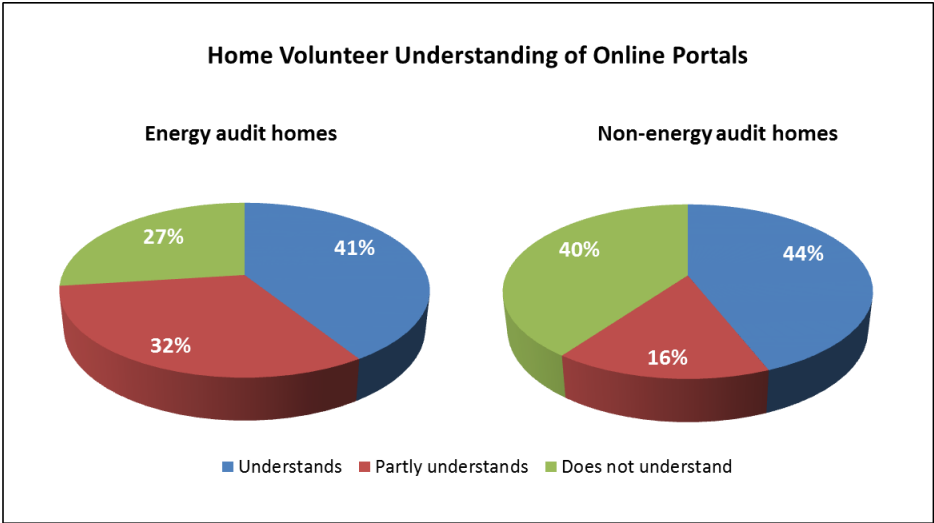

Figure 6-36: Home Volunteer Understanding of Online Portal

Web Portal Use for Better Energy Management

Thirty percent (30%) of the home volunteers who received an energy audit, compared to 50% of volunteers who did not receive an energy audit, said that they did not intend to use the web portal (Figure 6-37). Figure 6-38 shows that more audit volunteers planned to use their portal than non-audit volunteers for one or more of the purposes suggested in the survey.

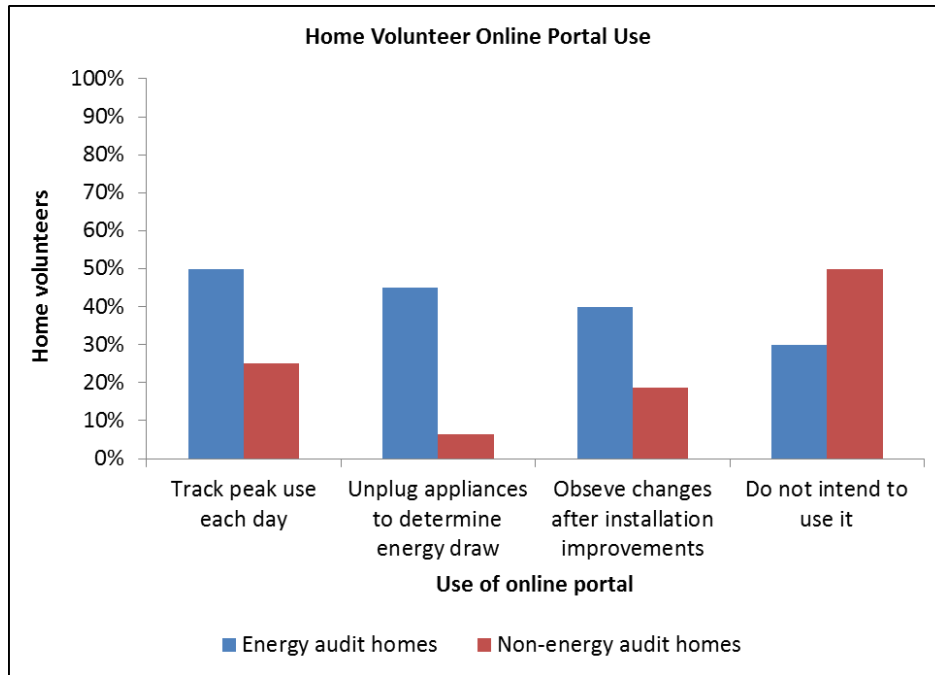

Figure 6-37: Home Volunteer Use of Online Portal

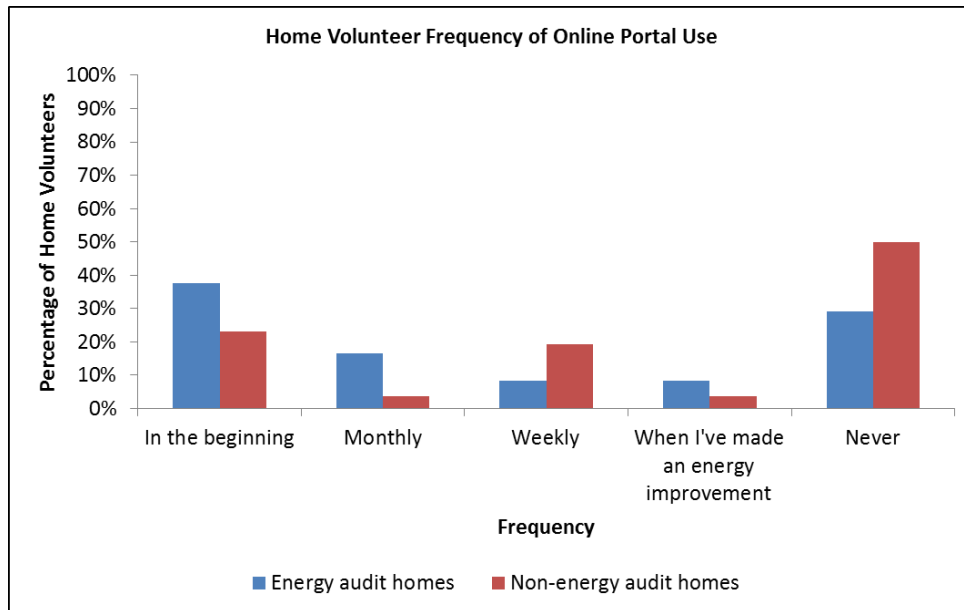

Figure 6-38: Online Portal Frequency

Data were collected from the web portals on volunteer login attempts for all participants in the project. This included the average amount of time spent on each login. The average number of web portal login attempts was 16.4 per volunteer. Descriptive statistics of web portal login attempts and the average time spent during each web portal login session are provided in Figure 6-39.

	Frequency	Average Session Length
Minimum	1.0	00:00:00
Maximum	509.0	00:11:21
Mean	16.4	00:02:02
Standard Deviation	67.0	00:02:28

Figure 6-39: Web Portal Login Statistics

Figure 6-40 shows the average length of time volunteers spent on their online web portals. The time range was between 0 and 11 minutes. Over half of the volunteers spent less than 1 minute on the portal.

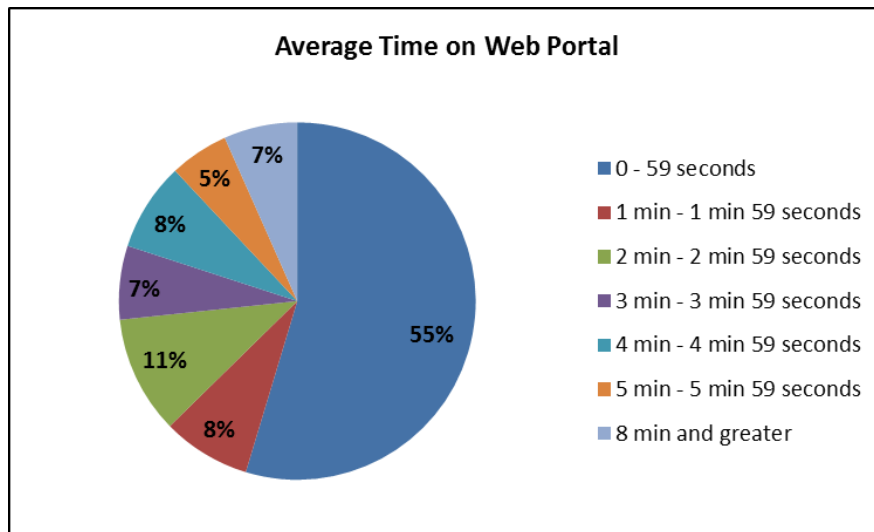

Figure 6-40: Volunteer Average Time on Web Portal

Web portal use was also analyzed to compare home volunteers who received a home energy audit and home volunteers who chose not to receive a home energy audit. Figures 6-41 and 6-42 show the average time spent on the web portal for energy audit volunteers and non-audit volunteers. The largest group of energy audit home volunteers (36%) spent an average of about 4 minutes on the web portal. The largest group of non-audit home volunteers (44%) spent less than 1 minute on the web portal.

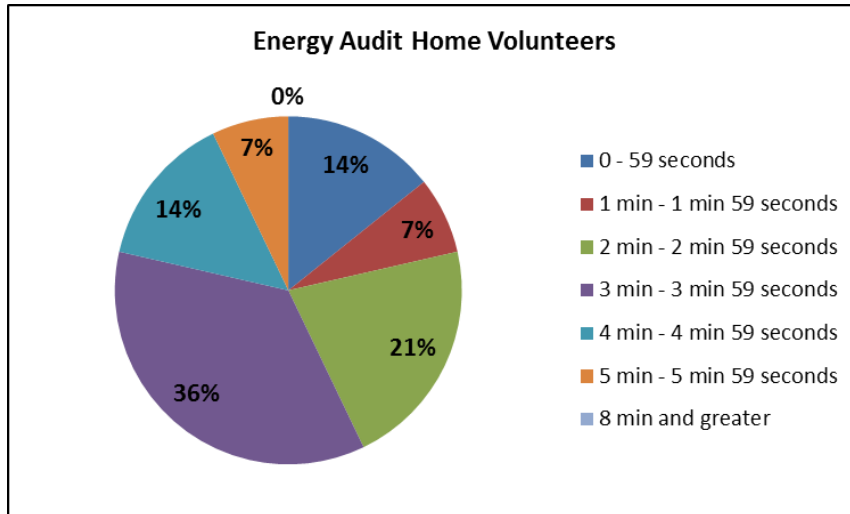

Figure 6-41: Average Time Spent on Web Portal by Audit Home Volunteers

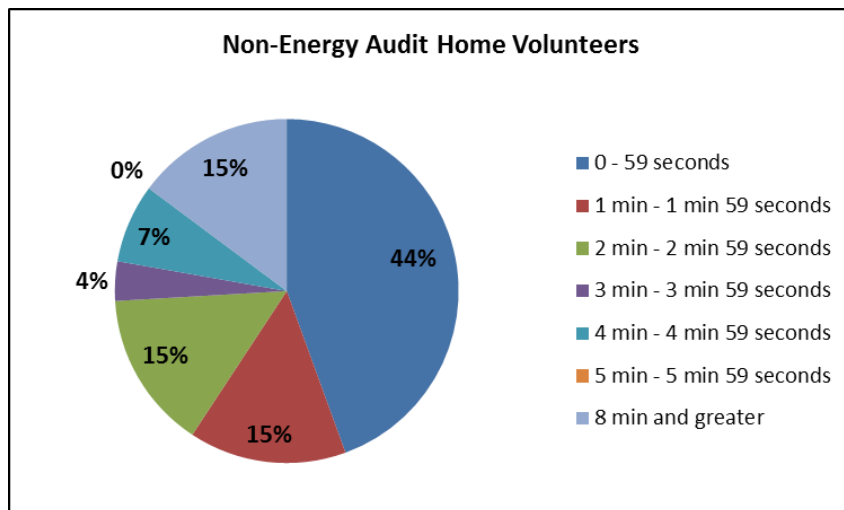

Figure 6-42: Average Time Spent on Web Portal by Non-Audit Home Volunteers

Post Energy Audit Online Portal Knowledge

Twenty home volunteers (83%) that received an energy audit stated that part of their interest in having an energy audit was to learn how to utilize their smart meters. For the homeowners who had their online portal already installed, the students provided the volunteers with an overview on how to use it. For the home volunteers who did not have their portals installed yet, or they had not received information about how to log in to their individual online portals, the students showed them a generic portal and walked them through the steps on how to use the portal.

In the six month follow up survey, home volunteers were asked if they had a better understanding about how their smart meter portal worked (see Figure 6-43). Of the volunteers who said they did not understand how to use their portals, several said that they had never been introduced to it or were not home when the energy audit took place. Others said they “needed a refresher,” “needed to use it more,” or “had not really used it.” One person cited smart meter incompatibility with their PV system.

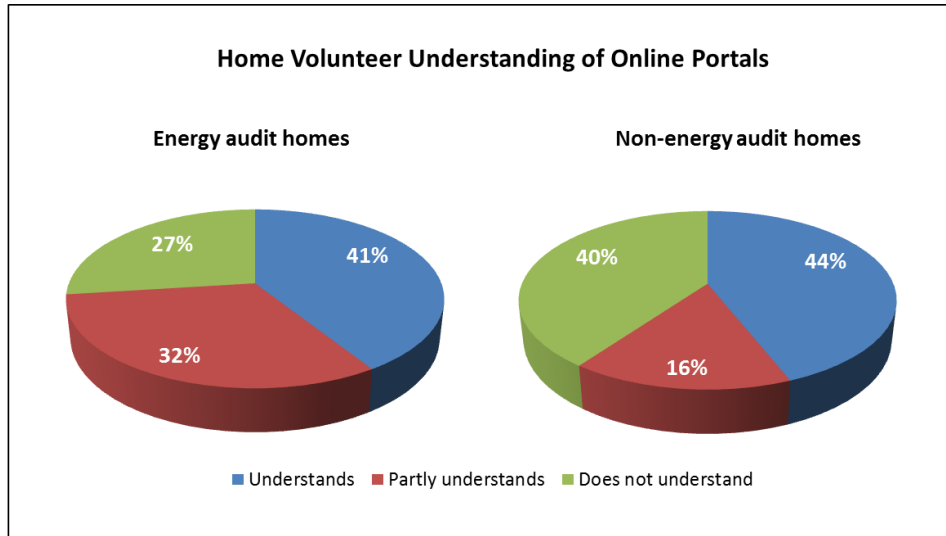

Figure 6-43: Home Volunteer Understanding of Online Portal

6.2.3.3 In Home Device (IHD) Usage

There were 36 volunteers who signed up to receive an IHD. Twenty (20) of them had received an energy audit, and fourteen (14) did not receive an audit. Even though they signed up to receive an IHD, 5 of the 36 volunteers stated that they did not intend to use the device.

Home volunteers said that they liked the convenience and instant information of the IHD. For example, comments from the home volunteers about the IHD included: “[it] gives me an idea of what draws a lot of energy,” “I can see real-time energy usage,” and “The IHD is great. It tells me when I am generating power and my net generation/use; easy to use, real time information.” Some volunteers said they disliked the IHDs because of connection problems and signal consistency. Figure 6-44 shows comments from volunteers regarding the IHD.

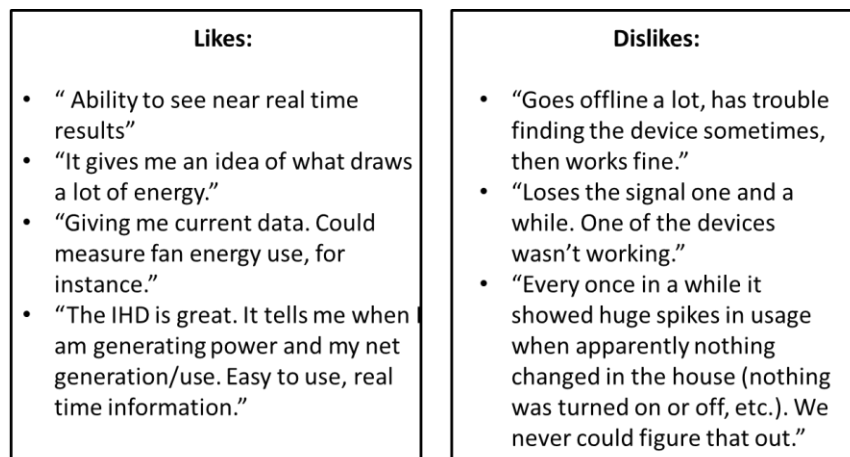

Figure 6-44: Home Volunteer Comments on In-Home Device

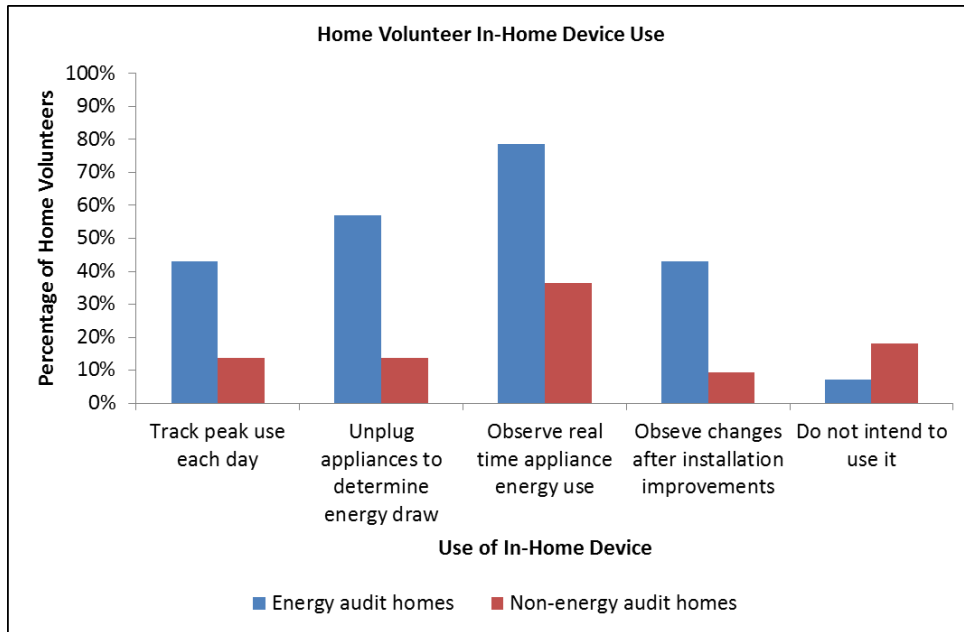

Figure 6-45: Home Volunteer In-Home Device Use

6.2.4 Battery Energy Storage System (BESS)

6.2.4.1 System Impact Tests

In order to have an understanding of circuit response to the active and reactive power injections, several tests were performed. In these tests, the BESS is operated in dispatch mode where the active and reactive power commands are sent from the dispatch room.

Active power absorption test

In the first test, active power is absorbed with 50kW steps every five minutes, and reactive power output is set to zero, as shown in Figure 6-48. The active power demand of circuit 1517 increases gradually due to charging of the BESS, while the reactive power stays almost constant as shown in Figure 6-50. The voltage profile in Figure 6-49 shows that the active power absorption affects the voltage significantly. However, the change in voltage is primarily due to the response of the load drop compensation of the Load Tap Changer (LTC) responding to the increase in load from the BESS, rather than the LTC responding to changes in voltage at the substation. Therefore, since the active power of the battery does not have much of an impact on the substation voltage, MECO decided it is more suited for shaving the peak load. The transformer LTC and other voltage regulation equipment will be used to manage the circuit voltage. However, as shown in Figure 6-49, the LTC operation needs to be coordinated with the operation of the BESS. Figures 6-46 and 6-47 present this test's conditions and settings, respectively.

Date / Time	May 30, 2014 / 12:05 a.m.
BESS Mode	Manual
BESS Bus Volt Ref Setpoint	12470V
Starting Average SOC	12.9%
Ending Average SOC	92.1%

Figure 6-46: BESS conditions for kW absorption test

Time	BESS charge setting	Time	BESS charge setting	Time	BESS charge setting
12:05	0	12:45	400	13:25	800
12:10	50	12:50	450	13:30	850
12:15	100	12:55	500	13:35	900
12:20	150	13:00	550	13:40	950
12:25	200	13:05	600	13:45	980
12:30	250	13:10	650	13:50	980
12:35	300	13:15	700	13:55	975
12:40	350	13:20	750	14:00	0

Figure 6-47: BESS conditions for kW absorption test

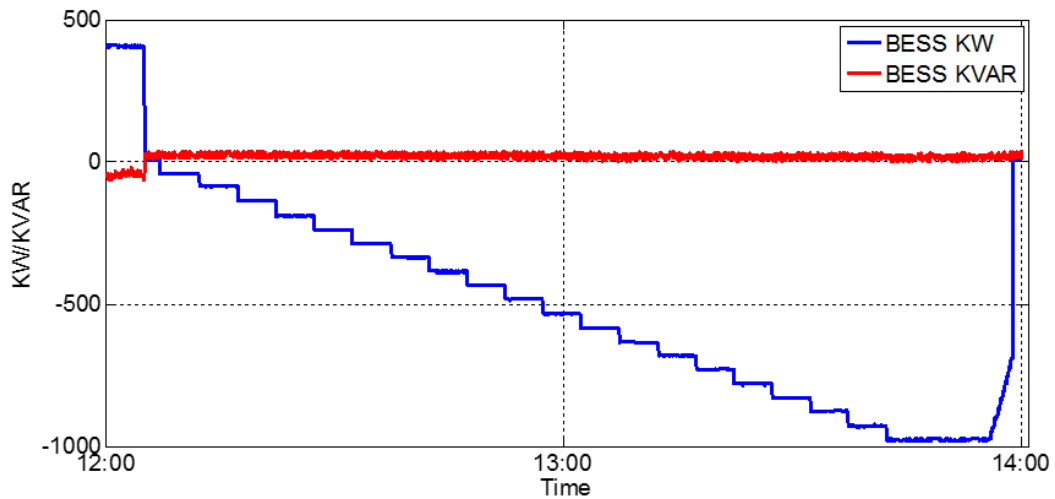

Figure 6-48: Active Power Absorption Test

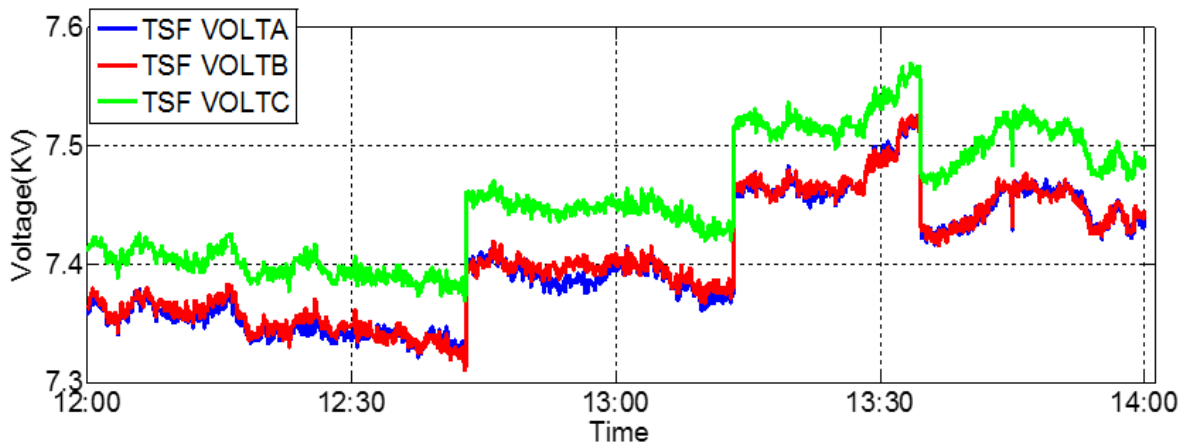

Figure 6-49: Power measurements for the active power absorption test

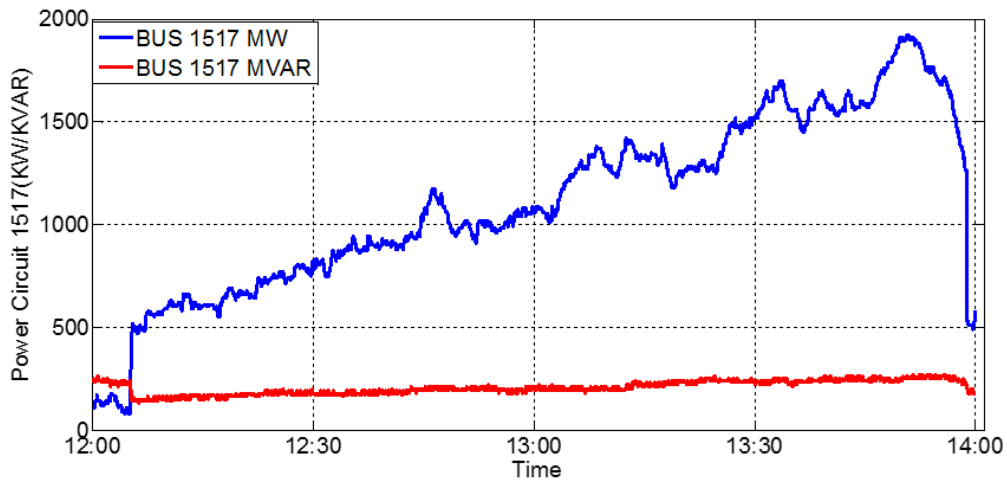

Figure 6-50: The voltage profile for active power absorption

Active power injection test

In the second test, active power is injected with 50kW steps every five minutes and reactive power output is set to zero, as shown in Figure 6-53. The active power demand of circuit 1517 decreases gradually as the BESS increases its injection of active power to the distribution grid; thus less power is drawn from the MECO bulk transmission system. The circuit load is much more variable than in the previous active power absorption test due to the variability in PV power output on the circuit during this test. As with the previous test, the voltage at the substation does not vary with the changes in output from the BESS: the substation voltage changes result from changes in the LTC in response to the change in current due to the injection from the BESS and changes in PV output. Active and reactive power flows of BESS and circuit 1517 are depicted in Figures 6-54 and 6-55, respectively. The voltage of the distribution transformer is shown in Figure 6-56. The LTC setting changed three times to regulate the voltage. Figures 6-51 and 6-52 present this test’s conditions and setting, respectively.

Date / Time	May 29, 2014 / 11:55 a.m.
BESS Mode	Manual
BESS Bus Volt Ref Setpoint	12470V
Starting Average SOC	100%
Ending Average SOC	52.2%

Figure 6-51: BESS conditions for kW injection test

Time	BESS charge setting	Time	BESS charge setting	Time	BESS charge setting
12:00	00	12:40	400	13:15	750
12:05	50	12:45	450	13:20	800
12:10	100	12:50	500	13:21	705
12:15	150	12:55	550	13:22	507
12:20	200	13:00	600	13:23	310
12:25	250	13:05	650	13:24	113
12:30	300	13:10	700	13:25	00
12:35	350				

Figure 6-52: BESS discharge Setting (kW)

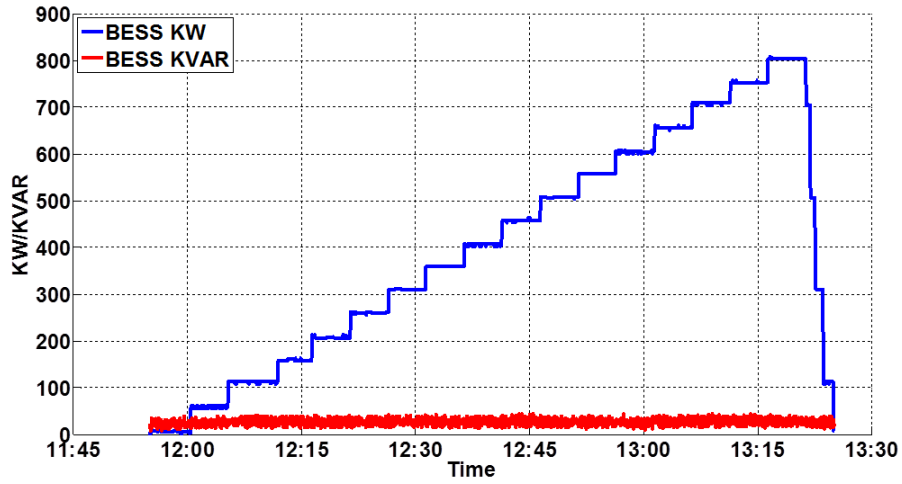

Figure 6-53: BESS discharging in 50kW steps

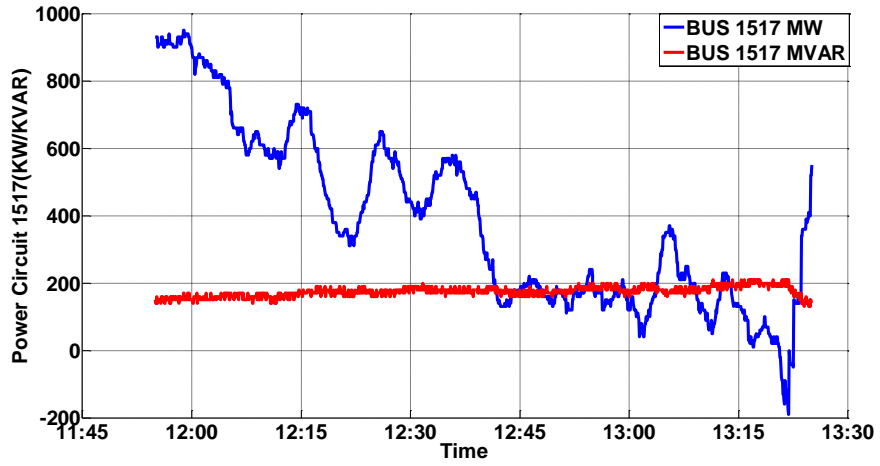

Figure 6-54: BUS 1517 active power demand while BESS being discharged

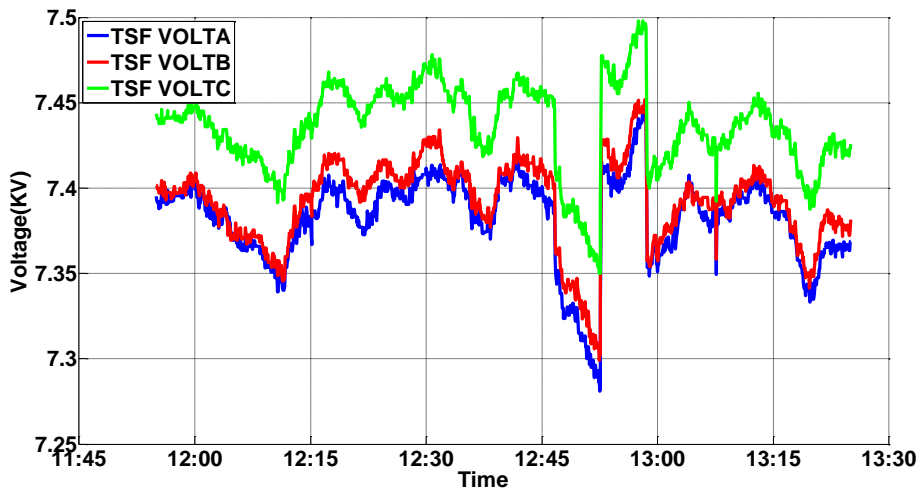

Figure 6-55: BUS 1517 voltage while BESS being discharged

kVAR absorption test with 50kVAR steps:

In this test, reactive power is absorbed in 50kVAR steps to examine the effect on transformer voltage level of VAR absorption. The reactive power absorption did not change BESS's SOC; the initial and final SOC values are almost the same. The small reactive power change also did not have a significant impact on the voltage level of the transformer. There was a voltage spike at 00:35 due to the switching of a capacitor at the substation and another at 01:46 when the VAR injection ended abruptly. The second spike may be due to the MECO system generation's compensating effectively for the slow increase in VAR absorption during the test but not reacting in time for the abrupt change when the absorption stopped. The test conditions are given in Figures 6-56 and 6-57. The BESS power, transformer voltage and 1517 circuit power are shown in Figures 6-58, 6-59 and 6-60 respectively.

Date / Time	June 1, 2014 / 12:05 a.m.
BESS Mode	Manual
BESS Bus Volt Ref Setpoint	12470V
Starting Average SOC	9.9%
Ending Average SOC	11.5%

Figure 6-56: BESS conditions for kVAR absorption test

Time	BESS charge setting	Time	BESS charge setting	Time	BESS charge setting
12:05	0	12:45	-400	13:25	-800
12:10	-50	12:50	-450	13:30	-800
12:15	-100	12:55	-500	13:35	-800
12:20	-150	13:00	-550	13:40	-800
12:25	-200	13:05	-600	13:45	-800
12:30	-250	13:10	-650	13:50	off
12:35	-300	13:15	-700		
12:40	-350	13:20	-750		

Figure 6-57: BESS discharge setting (kVAR)

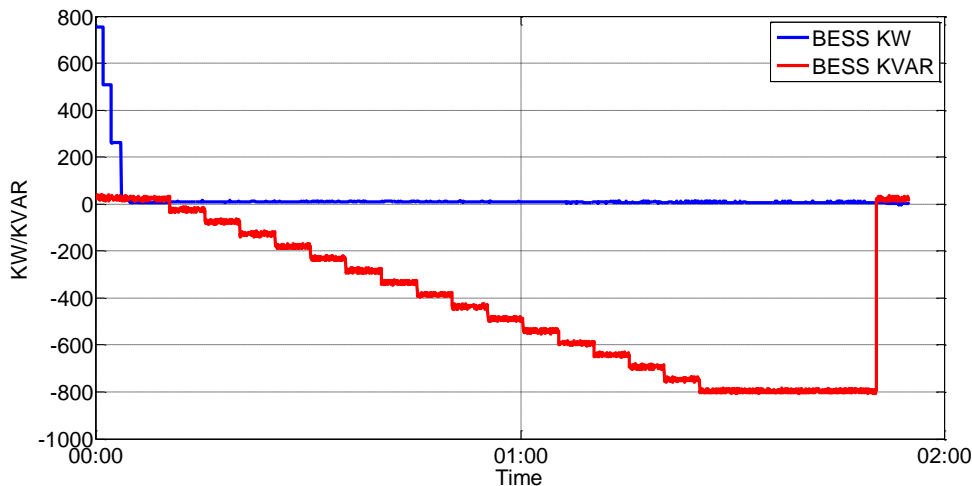

Figure 6-58: BESS power for kVAR injection test with 50kVAR steps

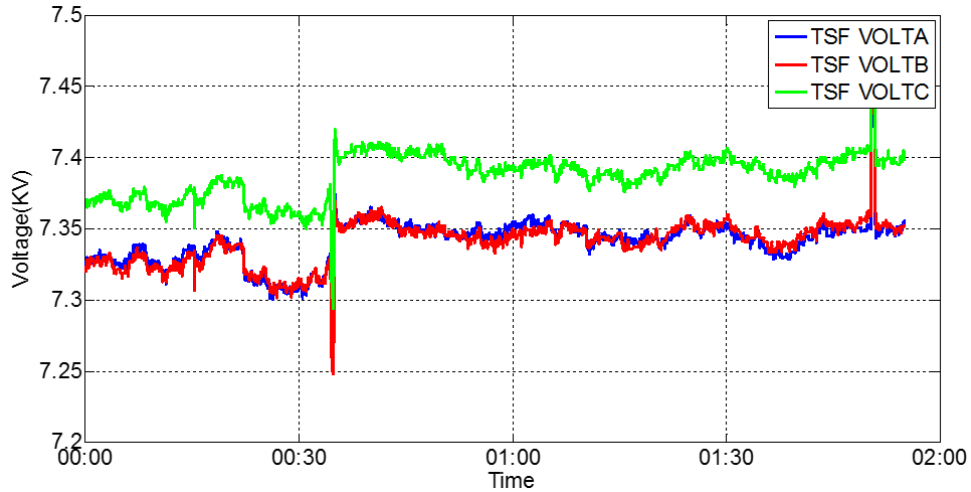

Figure 6-59: Transformer voltage for kVAR injection test with 50kVAR Figure steps

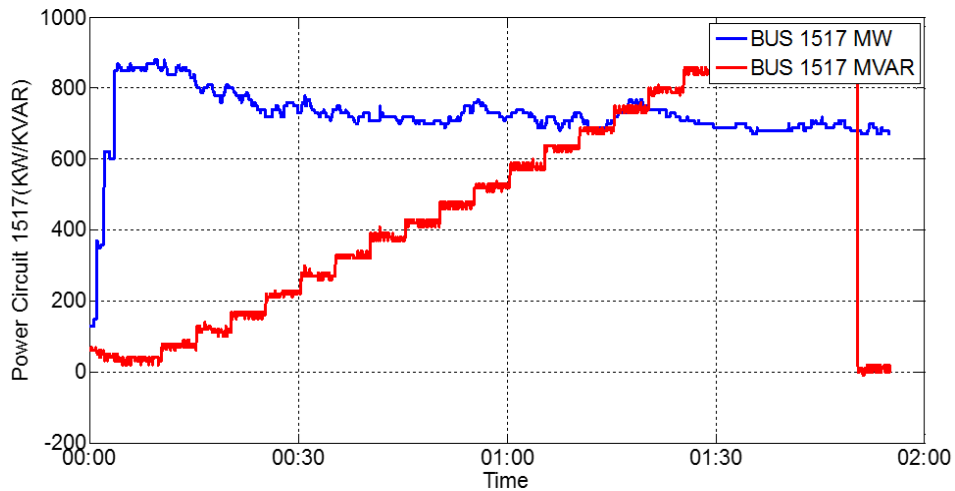

Figure 6-60: Power circuit for bus 1517 - kVAR injection test with 50kVAR steps

kVAR Injection test with 200kVAR steps:

In the previous test, small reactive power injections did not affect the voltage greatly. Therefore, for this test, VAR injection was done in 200kVAR steps, in order to have a greater effect on transformer voltage. However, the impact was still not significant, on the order of about 0.7%. The BESS power, transformer voltage, and 1517 circuit power are shown in Figures 6-63, 6-64 and 6-65 respectively. The test conditions are given in Figures 6-61 and 6-62.

Date / Time	June 5, 2014 / 7:00 p.m.
BESS Mode	Manual
BESS Bus Volt Ref Set point	12470V
Starting Average SOC	100%
Ending Average SOC	98%

Figure 6-61: BESS conditions for kVAR absorption test

Time	BESS charge setting
19:00	25
19:05	225
19:10	425
19:15	625
19:20	825
19:25	25
19:30	25

Figure 6-62: BESS discharge setting (kVAR)

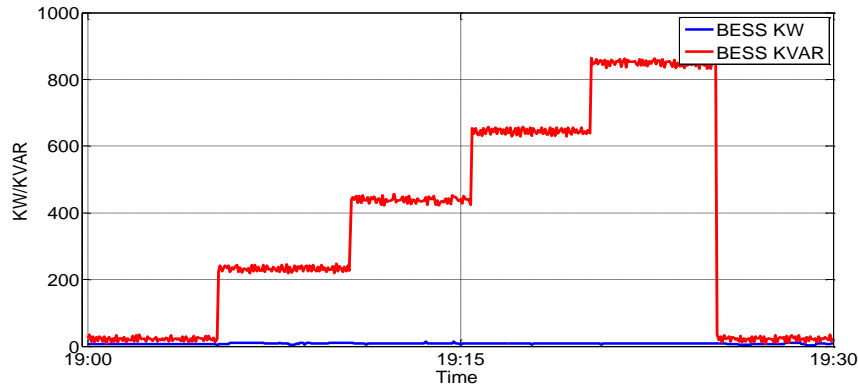

Figure 6-63: The active and reactive power output of BESS for kVAR injection test with 200kVAR steps

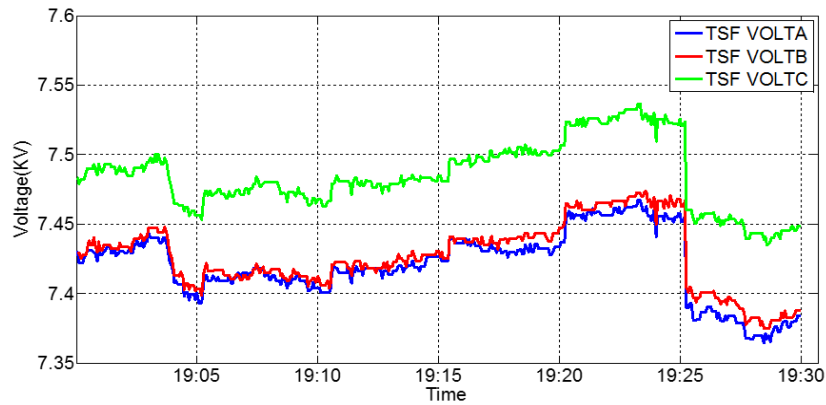

Figure 6-64: The transformer voltage variations for kVAR injection test with 200kVAR steps

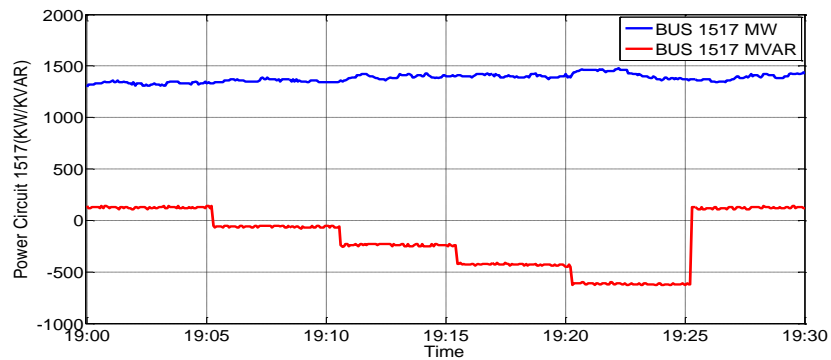

Figure 6-65: Power circuit for bus 1517 - kVAR injection test with 200kVAR steps

At the end of the test, when the BESS stops supplying kVAR, 800kVAR is abruptly absorbed from the grid, leading to sudden voltage changes. The change in voltage due to abrupt reactive power drop is calculated according to the following figure:

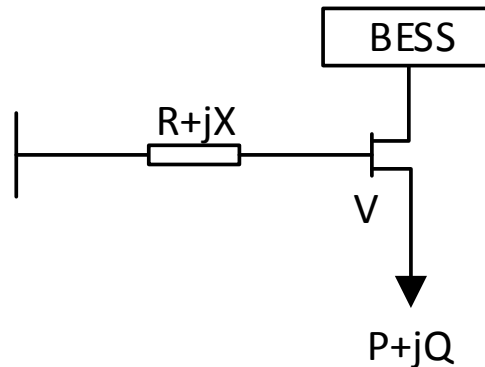

Figure 6-66: System schematic

In this figure the voltage change at BESS bus caused by reactive power absorption/injection is calculated from the following formula:

$$\Delta V \approx \frac{RP + XQ}{V}$$

Since there is no active power injection from the battery, the above formula reduces to the following:

$$\Delta V \approx \frac{XQ}{V}$$

Using the PSS-E model, the reactance between Wailea and Kihei is .0074 p.u., with .09 p.u. of transformer reactance, so the total reactance is .0974 p.u. This leads to the following statements:

$$S_B = 100MVA$$

$$V_b = 69KV$$

$$Z_B = \frac{69KV^2}{100MVA} = 47.61\Omega$$

$$Z_{Branch_Wailea_Kihei} = .0974 \times 47.61 = 4.6372\Omega$$

$$Z_{Singlephase} = \frac{4.6372}{3} = 1.54\Omega$$

$$\Delta V = \frac{1.54 \times 266KVAR}{7.5KV} = 55V$$

The values obtained from the graph and calculations are almost the same. Normalizing the voltage change gives:

$$\Delta V_{p.u} = \frac{55V}{7.5KV} = 0.0073 p.u$$

Therefore, the conclusion is that reactive power injection from BESS does not have significant impact on the bus voltage. This indicates that it would be more useful to dispatch the battery for load leveling at active power and use the rest of battery capacity to meet the distribution feeder’s reactive power demand to reduce losses. As a result, not only does the active power from the BESS increase the capacity of the feeder and reduce losses on the transmission system, but reactive power from the BESS can be used to provide the reactive power needs of the circuit without significantly affecting the voltage or the BESS SOC. This will further reduce losses on the transmission system.

6.2.4.2 BESS Efficiency Test

The actual efficiency of grid energy storage is one concern for developing it for grid applications. To measure efficiency for the installed BESS, the data from the active power injection/absorption tests were used. The imported/exported energy from the BESS were divided into specific ranges of SOC. Dividing those numbers gives the round-trip efficiency (RTE) of the installed BESS under load. RTE average value of BESS is 89.3%. The following table shows the RTE calculation:

SOC	Energy Difference (Watt-hour)
82% to 23% discharge	41896
23% to 82% charge	46869
RTE =41896/46869=89.3%	

Figure 6-67: RTE calculation

6.2.4.3 Peak Load Reduction

Demonstrating a 15% peak load reduction is a key DOE objective for the project. To do this, the BESS must first be fully charged. Then, based on the historical load of Feeder 1517, the BESS should be discharged to maximize the load reductions during the peak hour. The maximum discharge (without affecting battery life due to deep discharge of the BESS) is 1.0 MWh.

The procedure to maximize feeder peak reduction is:

- Using historical feeder load shape data plus the current load and weather forecast, estimate the expected power load as a function of time for Feeder 1517; $PF(t)$.
- Because the usable BESS capacity is 1 MWh, **minimize the setpoint target PF_{target}** such that:
 - The total of the BESS power output ($PB(t)$), both discharge (+) and charge (-) over the day, will not exceed 1 MWh:

$$1 \text{ MWh} > \int PB(t) = \int [PF(t) - PF_{target}]$$

- At no time will the SOC be lower than the minimum acceptable State of Charge, where:

$$SOC(t) = SOC(0) - \int [PF(i) - PF_{target}] \text{ integrated over the interval } i = 0 \text{ to } i = t$$

Where:

$PF(t)$ = forecasted feeder load at time t

$PB(t)$ = BESS discharge (+) or charge (-) at time t

- Once the desired feeder setpoint has been calculated, dispatch the BESS in Load Smoothing/Peak Shaving (LS/PS) mode, with PF_{target} as the setpoint.

The BESS LS/PS mode is utilized to keep a constant load level on the distribution transformer at a lower peak load, PF_{target} . For the Maui Meadows feeder, the lowest upper limit for Feeder 1517 is calculated to be 1.187 MW. This means that BESS will automatically charge/discharge to compensate for power deviation from the set point. However, the BESS SOC cannot be higher than 100% (1.2MWh) or lower than the minimum permissible SOC. Also, the rate of charge or discharge, $PB(t)$, cannot exceed 1 MW.

The BESS SOC and active power load for the test are presented in Figures 6-69 and 6-70. Test conditions are shown in Figure 6-68.

Date	June 1 to June 3, 2014
Duration	3*24 hours
BESS Mode	Peak shaving mode (LS/PS)
Bus peaks shaving Ref Set point	1.187 MW
Starting Average SOC	75%
Ending Average SOC	55%

Figure 6-68: BESS conditions for Peak Shaving test

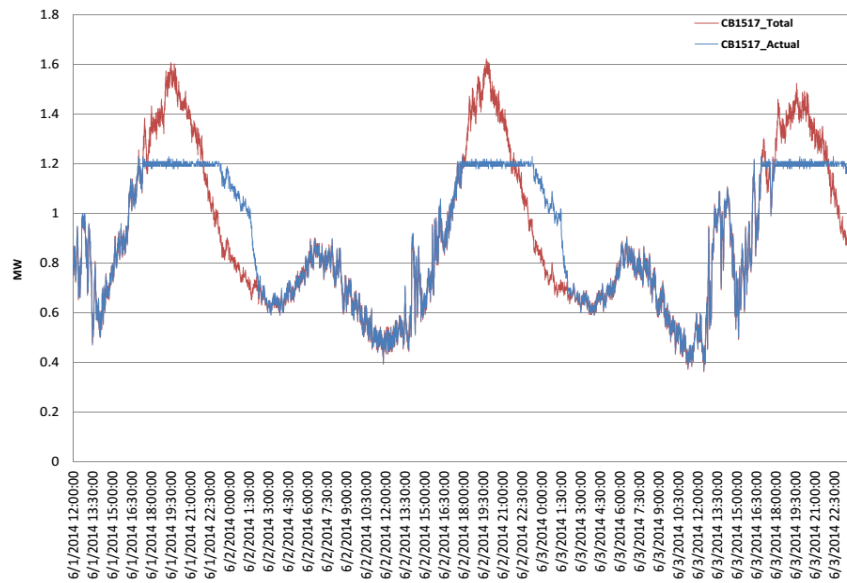

Figure 6-69: Bus 1517 – active power

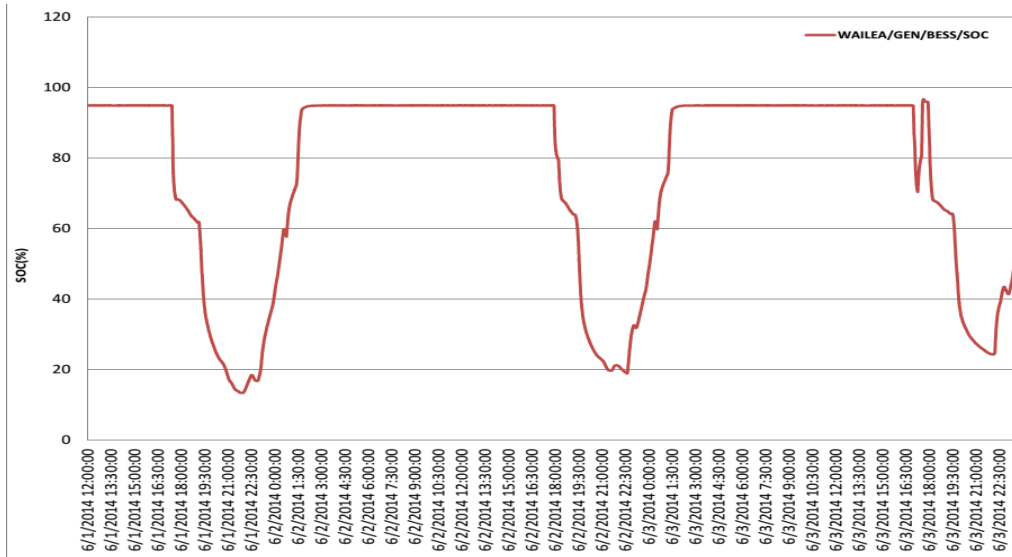

Figure 6-70: BESS SOC for manual peak shaving mode

The percentage of maximum peak shaving in this test for three consecutive days are as follows:

$$\text{Peak reduction percentage} = \frac{\text{Peak load} - \text{shaving setpoint}}{\text{Peak load}} \times 100$$

$$\text{First day (June 1): } \frac{1607 - 1187}{1612} \times 100 = 26\%$$

$$\text{Second day (June 2): } \frac{1612 - 1187}{1515} \times 100 = 26\%$$

$$\text{Third day (June 3): } \frac{1515 - 1187}{1515} \times 100 = 21\%$$

The total line loss is calculated via PSSE at peak time. Line losses with and without 1 MW BESS are 50.73441624 and 50.823563873 which shows a difference of 0.0891kW.

7. SUMMARY OF RESULTS, CONCLUSIONS & ACCOMPLISHMENTS

7.1. Overview

This project provided MECO with an opportunity to evaluate the capability of several advanced systems and technologies to resolve issues faced by MECO and its customers: high energy costs, the need to manage high penetrations of as-available renewable energy, and constraints on expanding the power system to serve load growth. The Wailea substation and Feeder 1517 serving the Maui Meadows neighborhood were chosen as the site of the Maui Smart Grid Renewable and Distributed Systems Integration demonstration project because they were typical of MECO's residential customers and the power system assets serving them.

Since this was a pilot project, not a full system rollout, MECO and the HNEI project team recruited volunteers from Maui Meadows residents. Due to Hawaii Public Utility Commission (PUC) rules, MECO could not offer any financial incentive to ratepayers to participate, as that would constitute a change to their energy tariffs. As a result, HNEI and its project partners embarked on an extensive outreach and education effort, to explain to the Maui Meadows residents what the "smart grid" was, the operations problems facing MECO, and how smart grid technologies had the potential to resolve those problems while offering improved service and, ultimately, cleaner and lower cost electricity to Maui residents.

This approach actually proved extremely valuable during the project. There are a lot of misconceptions about "smart grid" and, especially, "smart meters." The time the project team took to meet with residents and to explain the technologies and their objectives helped defuse anxieties about modern grid technologies. (e.g., "Are smart meters being used to spy on me?" "Will I be subjected to harmful radio frequency radiation?" "Is this going to benefit MECO but cost me more money?") Since the project team was enlisting non-compensated volunteers, we had to be very attentive to customer questions and concerns. Of course, those who volunteered to participate could not be viewed as an average sample of MECO residential customers; the participant sample was biased toward those with more energy awareness and environmental concern than the typical Maui resident. Thankfully, this resulted in project participants who were generally patient and understanding about project delays and systems that needed to be "tweaked" to work correctly.

One incentive that HNEI and MECO could – and did – offer was to perform energy audits of any participant's home who requested an audit. The audits offered an additional opportunity to educate the project volunteers about their energy use, and also helped lend a more human face to the project. Many audits found problems with appliances, controls, or setpoints that resulted in immediate energy and cost savings. By training local college students to do the audits, the project also provided important workforce training benefits that were a key objective of the ARRA funding that provided the federal financing of the project. (MECO co-funded over 50% of the total project costs.)

By first completing a pilot test of smart grid capabilities, MECO has gained insight into which functions, capabilities and technologies will provide the most value to its customers. For example, while the proponents of the "smart grid" often cite the information and choices that smart meters offer the consumer, this demonstration project showed MECO what information customers *really* wanted, and how they wanted it presented to them. A significant accomplishment of the project was obtaining customer input *before* any system-wide implementation.

The project spanned a period when the number of new distributed PV installations in Hawaii was doubling every year. From a system operation perspective, the higher than expected penetration of PV revealed new requirements for monitoring and control of distribution system assets and load flow simulation models. For example, initially the project team assumed that monitoring PV output at 15 minute intervals would be sufficient. Soon after the performance test period began, it became apparent that a much more rapid reporting rate was desirable. MECO and HECO applied this “lesson learned” to immediately augment the system requirements for smart grid projects being implemented in Maui (e.g., Maui Advanced Solar Initiative – MASI) and Oahu.

This rest of this section describes the primary results and conclusions of the project.

7.2. Load, Voltage and PV Profiles

While the 88 project participants did not represent a statistically significant and unbiased sample of MECO’s residential customers, the average of the Maui Meadows participants’ home energy use profiles is similar to MECO’s residential class load shape. Close examination of some home and appliance load shapes suggests that many Maui residents do not leave their A/C on all day, but turn it on (or lower their thermostat setting) when they return home in the afternoon or evening. This limited time of A/C use may be motivated by the high cost of electricity. A “surge” in A/C load in the afternoon or evening is consistent with MECO’s observed late afternoon residential peak. It also suggests that demand response that curtails A/C use may: 1) not yield much load relief early in the day, and 2) may not be acceptable to the customer if activated in the afternoon when residents are trying to cool down a hot house.

The smart meters also measured voltage at the customer’s service entrance. Examining these voltage profiles showed more than expected high (swells) and low (sags) voltages, and not always in locations where one would expect high or low voltage. MECO adjusted distribution transformer taps to better maintain observed voltages within acceptable limits, significantly improving the quality of service to Maui Meadows residents.

However, much of the incidence of out of limit voltages seemed to be the result of high penetrations of PV panels on the feeder. There are many more over voltage violations than under voltage violations. Because PV outputs vary significantly (slowly with time of day and quickly with cloud cover), MECO is investigating the need for more active control of voltage, through switched capacitors and other devices.

One of MECO’s most important goals for the project was to better determine how much electricity PV panels are actually generating system-wide. This time-varying level of PV generation affects how much operating reserve MECO must have on-line to support the as-available PV. By monitoring the PV panel outputs, using smart meters, MECO concluded that the aggregate amount of PV power generation across the feeder could be estimated using an irradiance sensor (pyranometer) in the substation. Studying the load flow along the feeder, and how it varies – often very rapidly – with changing irradiance levels suggested that MECO operations could benefit from knowing the amount of PV generation with far less latency than what is provided by 15-minute interval meters. Using a pyranometer enables PV estimates with far less latency. Locating the irradiance sensor in the substation normally will allow it to be monitored at 4 second intervals by the SCADA system using the substation’s RTU.

7.3. Customer Energy Use and Smart Meters/In-Home Displays

Shortly after the project began, the PUC introduced a residential tariff where consumers would pay a higher price per kWh after they exceeded a designated monthly energy allotment. This provided an immediate incentive for people in Hawaii to track their energy usage throughout the month, and it coincided with the project team's offering Maui Meadows residents the opportunity to do so by using smart meters, coupled with individual customer web portals or in-home displays (IHD) of household and appliance energy use profiles.

Do consumers act on the energy usage information provided by smart meters? At first glance the results seem dramatic. The energy use of Maui Meadows residents with smart meters and web portals decreased about 23% after their meters were installed, compared to the year before (Figure 6-20). After the smart meters were installed, the project volunteers on average used about 30 – 40% less energy than the average non-participant Maui Meadows resident (Figure 6-21).

However, the volunteers' energy usage began dropping immediately after the project started, before the smart meters were installed. Some of that lesser energy consumption can be ascribed to the fact that by deciding to participate, the volunteers – who were likely more energy conscious than the typical Maui Meadows resident to begin with – were prompted to act on their inclinations. However, it is also worth noting that during the year the smart meters were active, the volunteers' monthly energy use stayed approximately constant, while the non-participants' monthly energy use rose (Figure 6-21).

The project team concluded that providing smart meters (and energy use webpages) helped consumers to reduce their energy consumption. However, we cannot separate how much was the contribution of the smart meter itself and how much was due to the higher energy awareness of those who volunteered.

Comparing the energy use of those with IHDs with those participants with smart meters only, both groups showed decreased energy use after the equipment was installed (Figure 6-31), but the homes who chose IHDs averaged higher monthly energy use than those with smart meters only. The group that asked for IHDs had average higher energy use from the beginning of the project (i.e., even before the equipment was installed) (Figure 6-32), so it is possible that consumers with higher energy use were more likely to ask for IHDs.

Participants who chose both IHDs and energy audits showed significantly greater energy reductions than those who did not ask for an energy audit – both those with IHDs and those who did not have IHDs. It's possible that the additional per-appliance energy use data provided by the IHD enabled consumers to reduce their electricity consumption more. But, as with previous observations, one is cautioned against drawing conclusions about causality due to the small sample sizes and the possibility that those choosing IHDs and audits were more "activist" in energy conservation and would have reduced their consumption to some extent even without the equipment.

The observed reductions in energy use seemed to persist throughout the performance period year. However, participant interviews and web access statistics showed that the volunteers accessed the web pages and IHD less and less as time went on. It is interesting to note that all participant types demonstrated a large drop in energy consumption in August 2012, immediately after the smart meters were activated.

The overall conclusions from this aspect of the demonstration are:

- Providing consumers with smart meters and associated energy use webpages will result in reduced energy use.
- In-home displays (IHD) do not seem to significantly increase the amount of energy reductions above and beyond what the web portal provides.
- Residential energy audits do result in significant energy savings for those who request them. Providing such audits may be a valuable way to increase the acceptance of and energy use reductions resulting from smart meter installations.

7.4. Demand Response/Load Control

Demand response (DR) offers opportunities to reduce loads at times of system (or feeder) peaks or in response to variations of renewable energy output. The number of volunteers for DR was quite small; however, the results are promising enough that MECO may consider an expanded DR pilot to obtain better estimates of the possible load relief DR may afford. The major DR-related conclusions of the project were:

- A significant number of Maui Meadows residents keep their A/C off for most of the day, turning it on in the afternoon and evening. Thus, residential A/C may offer less of a DR resource during the day than expected
- Raising the thermostat of a central A/C unit 3 degrees F for one hour is probably an acceptable residential DR control strategy.
- Control of water heaters (WH) for an hour in “SCRAM” mode can likely mitigate sudden drops in as-available RE generation, or loss of other MECO generation.
- Control of WH for 1 hour is probably an acceptable residential DR strategy.
- Turning off the WH from 7 PM to 2 or 3 AM is probably acceptable, and offers the potential to increase minimum MECO system load (and thus reduce wind curtailment).

7.5. Battery Energy Storage System (BESS)

This project afforded MECO its first opportunity to operate a large BESS. The 1 MW / 1 MWh capacity battery was installed on Feeder 1517, close to the substation. As a result of the project, MECO has gained experience for specifying, installing and commissioning BESS in the future; this is important, as energy storage is proving to be an essential requirement for supporting high penetrations of as-available renewable energy sources. During the BESS procurement, more stringent safety-related requirements were imposed on BESS installations. MECO developed designs and operations plans for BESS to meet those new requirements.

When operated, the BESS demonstrated a round-trip charge/discharge efficiency of almost 90%. It was easily able to reduce the Feeder 1517 peak load by over 20% over the day. Testing of various operating modes showed:

- BESS is effective in load following mode, to “smooth” variations in loads and/or renewable energy production.
- The load following control command is also effective for minimizing peak by keeping maximum feeder load at or below a designated level.
- When located on the feeder, BESS charging and discharging does not markedly affect substation voltage. Setting feeder voltage is best done using transformer tap changers, switched capacitors, or other means.

- BESS is most effective at supplying active power (i.e., real kW) on the feeder, to reduce loading on the substation transformer and on the transmission system.
- BESS can supply reactive power (VAr) without significantly affecting its state of charge. Having BESS supply reactive power is effective in reducing transmission losses and thus reduces transmission congestion.

7.6. Volt/Var Control/DMS

The original design for Integrated Volt/Var Control (IVVC) was to use the DMS feeder load flow model to identify potential out of limit voltages along the feeder and suggest to the MECO operator changes to transformer tap settings to prevent this. However, the AMI voltage monitors revealed many more voltage excursions than anticipated (Figure 6-17). These included unexpectedly high voltages resulting from the large amount of PV along the feeder. The DMS load flow model did not have the capability to predict this accurately. HECO and MECO acted on this information to increase the voltage monitoring (number of points and scan rate) for subsequent projects: HECO's DVI demonstration on Oahu and MECO's MASI project on Maui. As a result, MECO and HECO are revising the design requirements for distribution system IVVC for future distribution automation implementation. The distribution load flow model must have full 3-phase capability to show phase imbalance, and it must be able to model individual phase injections on the feeder by PV panels. (When the energy generated by the PV exceeds the house load, a common occurrence in Hawaii, the PV acts as a distributed generator on one phase of the feeder.)

However, the use of IVVC study mode in the DMS proved valuable to adjust tap settings – both pole-top and substation transformers – to reduce occurrence of out-of-limit voltages. Also, up until now, MECO has been buying distribution transformers that only have the capability to buck up the voltage. The voltage monitoring and IVVC studies of the project showed that distribution transformers must also have the capability to set the voltage down (because of PV injection).

Thus, as a result of the MSGP, the Maui Meadows residents' quality of service was improved immediately by readjusting transformer taps. Moreover, by identifying the need to include additional capabilities in the purchase specifications for pole top transformers, service quality for all MECO customers will improve in the future.

As part of its cost share, MECO installed a separate data processing system, T-REX, to extract and manage SCADA data to provide case study data sets and formatted to be compatible with the DMS study mode, since using existing SCADA tools (e.g., historian) would have been unacceptably time consuming. T-REX will be part of future smart grid system rollouts for MECO and HECO.

7.7. Overall Project Objectives Accomplished

The project has provided valuable experience for MECO to specify, implement, integrate and operate RDSI technologies system-wide, including AMI, DR, DMS, IVVC, BESS, and renewable energy management. It did accomplish its seven overarching objectives:

- D-1: Reduce a distribution system's peak grid energy consumption: BESS successfully reduced Feeder 1517's peak load by over 20%. Proof of concept of two DR programs was accomplished: turning off WH for 1 hour or more, and raising A/C thermostat setpoints by 3 degrees for an hour. Finally, the project demonstrated the use of BESS and DR to manage PV

variability; by enabling the feeder to support higher levels of distributed PV, the feeder's peak load was further reduced.

- D-2: Improve voltage regulation and power quality within the selected distribution feeder: The voltage monitoring function of the smart meters identified out of limit voltage occurrences and resulted in adjusting tap changer settings to reduce out of limit voltages, thus improving service and power quality. The meter and feeder voltage monitoring, together with the volt/var study function of the DMS, were used to determine the correct transformer settings.
- D-3: Demonstrate that the architecture of the demonstration project is compatible with additional distribution management system functions, customer functions, and legacy systems: The project developed a platform that supported several "smart grid" functions, including AMI, DR, BESS, IVVC, and improved system visibility. These were integrated with legacy SCADA and transformer tap changer control systems. While some flaws were found in the initial designs, the lessons learned have already been applied. This project's initial architecture was leveraged as the basis for the MASI project, where smart inverters and additional functions were added, and MECO has completed interconnection of AMI, DMS, SCADA data collection and monitoring systems.
- D-4: Develop and demonstrate solutions to significant increases in distributed solar (photovoltaic systems) technologies: The PV metering, PV estimation using irradiance sensors, voltage monitoring and modeling, and smoothing of PV variations using BESS will all support higher penetrations of distributed PV systems by providing an understanding of the impacts of PV on a typical residential feeder.
- T-1: Provision for management of short-timescale intermittency from resources elsewhere in the grid, such as wind energy, solar energy, or load intermittency: BESS was dispatched to mitigate short time scale intermittency. The monitoring of PV output and analysis of its variability showed the need for faster monitoring of PV status. Establishing the strong correlation between irradiance measurements and PV output has validated a feasible approach to monitor such short-term intermittency using current SCADA systems.
- T-2: Provision for management of spinning reserve or load-following regulation: BESS was operated successfully in load following/regulation mode.
- T-3: Reduction of transmission congestion (through curtailment of peak load): BESS was used to supply real and reactive power on Feeder 1517, reducing transmission congestion. MECO studies show that such peak reduction could be important to prevent voltage collapse if a major transmission line trips. While this project showed that a BESS can be controlled to provide power when needed, the cost and impact of a BESS should be compared to that of other potential resources to determine what would be the preferred resource to be installed.

8. LESSONS LEARNED

The overarching goal of this demonstration project was to evaluate technical and procedural methods to enable MECO to continue to provide reliable, affordable and environmentally acceptable electric service to Maui's residents. The "smart grid" functions investigated focused on 1) providing MECO customers with more information on their energy use; 2) improving quality and reliability of service to customers; and 3) enabling the MECO grid to support larger amounts of as-available renewable energy resources. Many smart grid projects implement technically sophisticated equipment and systems and seek to evaluate the benefits. MECO and the HNEI team took a very customer-oriented approach. The desire was to work closely with MECO customers to see which functions provided real value to them, and then determine how to implement those beneficial capabilities most cost-effectively.

In this, the project was a success. MECO gained insight from the demonstration system's scope and methods that will be used to specify advanced monitoring, control, and communications capabilities for system-wide implementation. Thus, the most important "lesson learned" was in planning for future adoption of advanced "smart grid" technology. Section 7 described many of the results of the demonstration. This section highlights the specific lessons, knowledge, and guidance that MECO can apply to implementing Maui's future electric grid. Such knowledge covers smart grid system designs, customer interface, MECO staff training and support requirements, and cost-effectiveness of certain smart grid capabilities.

8.1. Smart Grid System Design and Technology Options

Vendor Selection and Procurement

- Don't assume a technology provider is familiar with your business needs. Clearly define each party's responsibilities in an agreement.
- Don't assume a technology provider is familiar with other types of technology.
- One critical lesson we learned from the continual delays when dealing with the initial Distribution Management System (DMS) vendor was to avoid products that are in development and not yet on the market. The major selling points for selecting Alstom's DMS product were that it was ready to go, easily integrated into MECO's existing Energy Management System (EMS), and could demonstrate functions (i.e., volt/var optimization, conservation voltage reduction, outage management support) needed for the project.
- Have contingency plans for deploying technology. Delays in manufacturing and/or shipping can put a project at risk of missing critical deadlines.
- Different smart meters have different password characteristics. The password for the GE meters installed in this project gave full access, including the ability to push changes to the metering software. As a result, MECO meter staff had to personally access meters for all tests, changes and function implementations, as giving access to a vendor would contradict MECO's Information Assurance and Security Policies. This was a burden on MECO staff and caused delays and, in some cases, errors because MECO staff were not familiar with some of the procedures. A meter password system with more differentiation of level of access and functionality is desirable.

Volt/Var Control (VVC)

- The VV monitoring resulted in improved power quality for Maui Meadows residents.

- MECO has been buying distribution transformers that only have the capability to buck up the voltage. The voltage monitoring of the project showed MECO needs to use transformers that also have the capability to set the voltage down (because of PV injection).
- The modeling/simulation environment provided by Alstom was very valuable, as it enabled the project team to try out different settings and controls, and predict the results.
 - However, the simulation function could not recognize operating limits. I.e., MECO needed to run the simulation and see what happened; the simulation function did not identify out-of-limit occurrences and adjust the settings.
 - In the future Alstom will probably need to add an optimization function to the simulation model, to suggest what settings should be used.
- The higher than anticipated penetration of PV on the feeder could not be addressed with the current load flow model. A three phase model is needed that can also account for PV injection greater than local load (and PV injection not equal on all phases).
- When the high PV penetration showed the load flow model development was not adequate for VVC, MECO/HECO decided to try more extensive monitoring in the DVI project HECO was implementing on Oahu, using actual field measurements (instead of a model with limited granularity).
- For Feeder 1517, the only option for VVC was to move the transformer tap, since there were no switched capacitor banks on the feeder. Other resources on the feeder, not just transformer taps, will be needed in the future to manage voltage on high solar penetration feeders.

Integration With Other Utility Systems, Especially Legacy Systems

- Data archiving/reporting functions were important. MECO's T-REX system was used to extract data from the SCADA system; this proved to be essential for analysis, as being limited to using SCADA tools (e.g., historian) would not have been acceptable. (The T-REX implementation was part of MECO's cost share). T-REX will be part of full smart grid system rollout for MECO and HECO.
- Implementing new technology, such as smart grid functionality, has inherent issues with deployment. Systems development that would naturally occur over a period of years for mature functions (e.g., SCADA) happens rapidly when the state-of-the-art is in flux. As a result there are incompatibilities among versions of applications, and new functions may not be downward compatible to operate with already installed equipment due to limitations in firmware. Very rigorous factory testing is needed, and tests must include all older legacy versions of equipment and software. Having a test setup for meters and devices at a MECO office or MECO installation (e.g., in the instrumentation cabinet of the substation) enabled software upgrades and bug fixes to be first pushed only to equipment on MECO sites. This way, any problems due to version incompatibility or remaining software bugs could be discovered before they affected actual customers.
- Integration of the new DMS with the existing SCADA was critical. The DMS will not have its own RTUs and communications system; it needs to leverage the SCADA system.
- Integration with the Outage Management System (OMS) was also a critical issue. MECO used the OMS to connect AMI information (from Silver Springs) with the DMS.

Data Management and Sampling Intervals

- Measuring solar irradiance at substations using pyranometers can give an accurate estimate of the amount of PV generation on the system.
- Using AMI meters to measure PV output at 15 minute intervals did not give data with sufficient granularity to develop control algorithms (PV output changes occur too quickly). Four second (SCADA interval) pyranometer data is better; but it may even be necessary to obtain 1 second data to detect PV output variations. MECO and HNEI are currently studying this in the Maui Advanced Solar Initiative (MASI) project also on the Maui Meadows subdivision feeder.

8.2. Customer Interface and Education

- Outreach/education is critical. Public opposition is persistent and will not be easily appeased or persuaded through studies and/or promises.
- Set realistic goals for recruitment. It's important to not over estimate or under estimate the number of participants to make the project successful.
- Keep to a published time schedule. Volunteers can become frustrated in waiting for a promised deliverable. This can be interpreted as being unprofessional.
- Take time to explain. Make sure customers understand functions, and listen to their concerns. Venues with personal communication, such as neighborhood meetings and information booths at community events, proved very valuable.

8.3. MECO Staff Training

- This pilot project was essential for MECO to understand future staffing and training requirements for smart grid functions. There was much that couldn't be learned until actually working with the system.
- Make *all* utility personnel familiar with any smart grid programs being considered or projects being implemented. Customers will approach friends and acquaintances that work for the utility, to ask about the project and technologies. (This was especially true for questions about smart meters.) All MECO staff in effect became "ambassadors" of the MSGP, even if they were not directly involved. It was important that they could accurately answer general questions from the public and/or refer questioners to proper information sources. "I don't know" or guesses about the project were not acceptable responses, as the public expected any MECO employee that was asked to be knowledgeable about smart grid projects and issues.
- GIS-based data of the MECO system changes frequently. MECO needs internal capability to import GIS data into DMS. For this project, MECO relied on Alstom to import GIS data, but that resulted in delays
- This project was very useful in highlighting training needs for MECO (AMI and other staff support requirements) as well as for the private sector workforce (energy audits, smart grid technology installation).
- In particular, this demonstration project showed MECO the staff support requirements for a DMS. For full MECO system deployment of a DMS, significant full time staff support will be needed to keep network models up to date, run VV scenarios, etc. Don't underestimate staffing needs for smart grid functions.

- Choice of Server Operating System (OS) is important. MECO has limited capability to support servers. It was good that Alstom has an OS platform (LINUX) that MECO staff could support.
- Factory Acceptance Test (FAT) and Site Acceptance Tests (SAT):
 - Conduct due diligence on vendor claims; interview utilities already using the vendor's systems.
 - For FAT and SAT, be comprehensive in developing procedures and "pass criteria." Do not simply accept a vendor's FAT/SAT procedure; make sure you add tests reflecting your utility staff's actual activities.

Appendices

Appendix 1

Final Project Management Plan (PMP) & Statement of Project Objectives (SOPO)

Project Title: Managing Distribution System Resources for Improved Service Quality and Reliability, Transmission Congestion Relief, and Grid Support Functions

Instrument No. DE-FC26-08NT02871

Recipient: University of Hawaii

Project Director: Richard Rocheleau, Leon Roose

Report Date: 12/31/2014

A. Project Objectives

The project objective is to develop and demonstrate an integrated monitoring, communications, data base, applications, and decision support solution that aggregates distributed generation (DG), energy storage, and demand response technologies in a distribution system to achieve both distribution and transmission-level benefits. The application of these new technologies and procedures is expected to improve service quality and increase overall reliability of the power system along with reducing costs to both the utility and its customers.

Distribution-level benefits include:

- D-1: Reduce a distribution system's peak grid energy consumption, thereby demonstrating the ability to relieve transmission system congestion;
- D-2: Improve voltage regulation and power quality within the selected distribution feeders;
- D-3: Demonstrate that the architecture of the demonstration project is compatible with additional distribution management system functions likely to be implemented in a legacy system employing "Smart Grid" technology solutions; and
- D-4: Develop and demonstrate solutions to significant increases in distributed solar (photovoltaic systems) technologies being installed at residential and commercial locations.

At the transmission level, the solution will enable coordination of the operation of distributed energy resources (DER) to make the distribution system dispatchable, providing grid services such as:

- T-1: Provision for management of short-timescale intermittency from resources elsewhere in the grid, such as wind energy, solar energy, or load intermittency;
- T-2: Provision for management of spinning reserve or load-following regulation; and
- T-3: Reduction of transmission congestion (through curtailment of peak load).

The project is in two phases. In Phase 1, energy management architecture for achieving project objectives will be developed and validated. In Phase 2, these capabilities will be demonstrated at a Maui Electric Company, Ltd. (MECO) substation at Wailea on Maui. Specific demonstration objectives are to reduce the Substation's distribution system's peak power consumption from the

transmission grid by at least 15%, improve voltage regulation on the feeders, and to reduce the impact of short-timescale intermittency from as-available renewable energy resources. The project is under the leadership of the Hawaii Natural Energy Institute (HNEI). The project team includes MECO, Hawaiian Electric Company, Inc. (HECO), Sentech (a division of SRA International, Inc.), Silver Spring Networks (SSN), Alstom Grid, Maui Economic Development Board (MEDB), University of Hawaii-Maui College (UH-Maui College), and County of Maui.

In 2012, the project team's efforts focused on: selecting a vendor to supply a distribution management system (DMS); integrating the DMS with data from SSN's systems; installation of Advanced Metering Infrastructure (AMI) and Home Area Network (HAN) equipment for homes, PV panels, and load control devices; site acceptance testing and validation of AMI and HAN systems; factory acceptance testing of the Distribution Management System (DMS); and continued outreach to recruit volunteer participants and provide the community with information about the project and project status.

The project team continued with the detailed design phase of the battery energy storage system (BESS) and distribution management system (DMS). Due to a fire at another battery installation, MECO conducted an in-depth safety and risk assessment of the installation. The battery was shipped and installed in Q2 of 2013.

After a re-assessment of the expected equipment installation timeline and its effect on the project schedule, HNEI and MECO requested a no-cost time extension for the project from DOE, to ensure an adequate performance period for evaluation and data collection.

Project activity in 2013 centered on:

- Continuing with outreach to the project participants;
- Exercising the AMI-based functions of the system;
- Installing and testing the Alstom Distribution Management System (DMS);
- Integrating DMS and AMI functions;
- Completion of the customer survey by Sustainable Living Institute of Maui (SLIM) of the University of Hawaii Maui College (UHMC);
- Installing appliance-level eGauge monitors in selected homes;
- Collecting and analyzing data from the meters, distribution sensors, and eGauge monitors; and
- Installing and operating the Battery Energy Storage System (BESS).

The SLIM customer survey is an extremely important project activity. A chronic problem with "smart grid" rollouts in the U.S. has been lack of customer acceptance, often due to inadequate communication and education of the consumers as well as poor matches between smart grid functions and capabilities and consumer needs or desires. From the start, the Maui RDSI project implemented a robust customer outreach program, characterized by numerous meetings with Maui Meadows residents, an informative website, customer service and "help" assistance, offers of energy audits, and pre-and post-installation interviews and surveys.

The SLIM activities have been extremely successful in achieving these objectives. They will provide direction for MECO, HECO and HELCO to move forward with their smart grid programs in a manner that most benefits the customer. HNEI feels that the customer outreach methodology and the lessons learned from the customer communications are also broadly applicable to mainland utilities beginning to design smart grid programs.

In Q1 2014, the meter data collected was used to develop typical residential load profiles for the Maui Meadows residents and to calculate average PV profiles to analyze the effects of high penetrations of PV – and its attendant variability – on feeder and customer voltages. Correlations of the PV panels’ output with the substation pyranometer readings are being analyzed; the high correlation shows that MECO will probably be able to accurately estimate system-wide PV power generation using substation-sited pyranometers.

The initial command schedule for demand response (DR) was implemented, but there were problems verifying load control switch operation, and the DR commands were postponed while these were resolved. The DR tests were re-started at the end of Q1 2014.

In Q2 2014, the performance tests continued, with DR of water heaters (WH) and air conditioners (A/C) exercised; more data collected on load and voltage profiles of homes, PV, appliances, feeder and substation; and continuing analysis of the data. In Q3 2014, HNEI plans to exercise the BESS to assess the value of energy storage’s providing real and reactive power to reduce feeder and system peaks and to manage reactive power to support distribution voltages and reduce transmission losses. HNEI plans to extend the WH control period, to determine if WH loads can be shifted to nighttime low load periods without adversely affecting customer service. HNEI will continue to collect data on all aspects of the Maui Smart Grid operations and analyze those data in accordance with the project’s Data Analysis and Testing Plan.

Q3 2014 activities consisted of: 1) continued data collection of feeder, appliance, PV and meter data (AMI – energy use and voltage) through mid-September; 2) continuing DR of water heaters and A/C through mid-September; 3) updating data analysis methodology; 4) analyzing performance data and evaluating results and benefits; 4) customer outreach and debrief activities; and 5) removal of equipment from customer premises after performance period ended mid-September.

Q4 2014 activities consisted of analyzing the data obtained during the performance period, writing the final report, and preparing other project documentation.

B. Scope of Work

Phase 1 – Selection and Development of Technologies for Phase 2 Deployment

In this phase, the team has selected and developed technologies and procedures that will resolve power delivery challenges at the transmission and distribution levels. At the transmission level, these technologies promise several benefits, including the ability to reduce transmission congestion and peak loading of central generation, as well as the capability to provide ancillary services to the local utility such as spinning reserve, load-following regulation, and intermittency management. At the distribution level, these technologies can better regulate voltage within distribution feeders and improve power quality. The intention is to develop and demonstrate a Distribution Management System (DMS) that will coordinate the operation of distributed generation, energy storage, and demand response (DR) to allow the aggregated distribution system to be dispatchable and capable of providing benefits transparently and efficiently. The DMS control and communication platform implemented features capabilities for:

- An integrated distribution system control and communications architecture combining and coordinating:

- Advanced metering infrastructure (AMI) as a home portal for direct demand response signals, as well as structured electricity rates,
- Building automation to implement energy conservation and demand response, and
- Meter information gathering, mining, and reporting functions in the distribution system control platform;
- Energy management, implementing coordinated dispatch of DG, storage, and demand response on the feeder;
- Integrated volt/var control (IVVC) along the feeder;
- Enhanced sensing and monitoring of conditions along the feeder;
- Monitoring the actual output of PV installed on residences served by the feeder; and
- Tieline monitoring, allowing tighter dynamic control of the power exchange between the distribution system and the transmission grid.

In Phase 2, the technologies developed in Phase 1 are being demonstrated at the Wailea Substation on Maui. Maui was selected for the demonstration due to having growth in electrical load and one of the highest penetrations of wind energy in the nation (30% during periods of low load) as well as significant percentages of photovoltaic systems on residential and commercial buildings. Phase 2 will be used to demonstrate the ability of the proposed DMS to:

- Realize at least 15% peak reduction in grid power draw by the selected Substation's distribution circuit(s), leveraging DG, energy storage, and demand response; and
- Provide transmission-level services.

Task 1: Data Collection and Functional Requirements Definition

This task is complete. Activities included:

- Weekly meetings conducted between HNEI, Sentech, GE, HECO and MECO to discuss program direction and technical progress (these continue to be ongoing as part of overall project activities); and
- MECO continues to provide data, describe grid operational issues, and clarify issues related to MECO's distribution system.

Task 1.1: Collect and Estimate Feeder Data and Load Profiles for Wailea Substation

This task was completed in December 2009. Additional data will continue to be collected as needed. Data analysis was used to identify locations for feeder voltage and current sensors. PV installations in the subdivision continue to be updated, and the number of installed roof-top PV systems in the subdivision has more than tripled since the project began. As many as possible of these will be monitored in near real-time (through the AMI system). Also, locations for likely "end of line" residences were selected. These will be part of a special AMI metering "group" that will help calibrate the feeder model and check for voltage excursions outside of tolerance. The simplified circuit for the project has been simulated and real measurements from Maui Electrical System Analyses were applied to validate the model. Various Volt/Var control algorithms, DG resources, and DSM strategies will be implemented on the model to estimate their impact on the project objectives.

Task 1.2 – Establish a Technical and Economic Baseline Condition for the Selected Substation

This task was completed in December 2009 and the results presented to the Technical Review Committee, as described in Task 10 (TRC) in February 2010.

Task 1.3: Compile Wind Farm Energy Data

This task was completed in December 2009. The project team has received wind speed and wind farm output data from First Wind. The dataset includes hourly measured wind plant output and forecasted output at ten different time intervals from July 2007 to December 2008.

Task 1.4: Establish a Technical and Economic Baseline Model for Wind

This task was completed in December 2009. As the details on the types of distributed energy resources and demand side management programs are finalized, the project team can analyze how those resources can be used to manage variability of wind power on the system.

Task 1.5: Functional Requirements Specification

The system requirements for an Advanced Distribution Management System, communications architecture, and recommendations for demand response functions were **completed in December 2009** and submitted to NETL in a January 2010 report, and presented to the TRC in February 2010. Based on comments from the TRC, this architecture was refined to better focus on necessary hierarchical control features and to present the proposed system in terms of reference architecture. Additional monitoring of residential PV systems and voltage monitoring of selected “end of line” customers were added to the functional specification (these are not large changes to the system defined in the deliverable submitted to NETL in December 2009). Further refinements and changes to the functional requirements if needed are part of Tasks 2 and 3.

Task 1.6: Development of Data Flow Diagram

After the functional requirements definition was completed, the data flow diagram was developed for all of the equipment proposed in the project based on the functional requirements defined by the project team. This effort generated a detailed graphical representation of data flows between each function proposed for the project to help communicate the functions of each component. **The functional data flows were completed in December 2009** and will continue to be updated as specific equipment and functions are refined. The data flow diagrams were updated in April 2012 as part of the functional integration. These underwent a final project team review and were submitted in Q1 2013.

Task 1.7: Real-Time System Testing and Experiments

The initial purpose of this task was to establish a remote connection between the GE ENMAC system (DMS) located at the GE laboratory in Niskayuna and MECO to facilitate the implementation of DMS functions and updating of the feeder model with real-time data obtained from the MECO SCADA and additional sensors. The change from the GE ENMAC system to the GENe system during the fourth quarter of 2010 slipped the possible implementation of the remote data transfer to early 2011. Since this time, the project team has selected Alstom Grid as the DMS vendor; a detailed explanation for this choice was provided to DOE under Task 3.2.

After selecting the new vendor, this task has been modified to conform to the implementation schedule for Silver Spring Networks (SSN) equipment and the Alstom DMS vendor. The DMS implementation requires MECO system GIS data and information on the operational characteristics of distribution system equipment. MECO started transferring this information in

Q1 2012. All of the cyber security and data transfer mechanisms are in place to support this data exchange. The remote DMS procedures developed were utilized in the factory acceptance testing (FAT), where Alstom had remote access to the necessary SSN and MECO systems. In Q3 and Q4 of 2012 the project team worked to integrate the feeder model (on the DMS) with MECO SCADA data and the AMI system. The DMS FAT was completed in Q4 2012. The AMI system passed its Site Acceptance Testing (SAT) in Q4 2012. The DMS passed its SAT in Q2 of 2013, **completing this task.**

Task 2: Selection and Sizing of Distributed Energy Resources

The team identified the appropriate complement of DER (including DG and energy storage elements) to be used during the demonstration phase in late 2011. The team has enrolled volunteer customers to participate in demand response, energy monitoring (through a HAN), and PV monitoring applications for the project. While some additional volunteers for DR and PV monitoring may sign on, the installation contractor (HNU Energy) has completed the HAN and in-home display installations in Q3 and Q4 2012. The installation of load control switches and adjustable thermostats was completed in early 2013. All the advanced meters, including the PV smart meters, were installed in Q3 and Q4 of 2012. Initially PV panel output was to be monitored using the data gathering capabilities of the load control switches, but a change in Maui's building regulations has permitted installation of a second meter to monitor the PV. As MECO rolls out its advanced metering and other advanced grid systems in the future, using revenue-grade and auditable meters to record PV use will probably be preferred, so the project team decided to use additional advanced meters to monitor PV.

MECO has completed contracting for a substation-level energy storage system (the selection and sizing of this equipment were completed at the end of 2011). Due to a fire at another battery installation, MECO conducted an in-depth safety and risk assessment of the proposed Wailea substation installation. This required development of an augmented safety plan and some additional site preparation. The battery vendor, A123, declared Chapter 11 bankruptcy, but the battery was shipped to Hawaii in Q2 2013. The battery was installed and was fully operational in Q2 2013.

The deliverable final report describing the DER was completed and was submitted in Q3 2012. This report will be updated as additional customers sign up, including PV and load control customers, and as the Battery Energy Storage System (BESS) is installed. **This task is complete.**

Task 2.1: Distribution System Model

A simplified circuit model of the selected Substation's distribution feeder was assembled to establish the technical and economic baseline described in Task 1.2. This model will continue to evolve as data is collected from the feeder and substation, DER assets are further identified and the Distribution Management System (DMS) is developed. In Q3 2012 Alstom updated the model with recent MECO data (from the SCADA and the MECO GIS project) system. The model was demonstrated during the Q4 2012 factory acceptance test. The model was updated again before the DMS was shipped to Maui for the site acceptance test in 2013. **This task was completed Q2 2013.**

Task 2.2: Preliminary Identification of DG Assets

This Task was completed Q1 2012. The project team finalized existing and planned DG assets for utilization in the project, as described below:

- Controllable transformer tap changers.
- Residential demand response (DR), including load dashboard, controllable water heaters, and HVAC thermostats. As the customer communication, outreach and recruitment programs are implemented, the specific numbers and locations of each DR installation will be determined. MECO must be careful to adhere to PUC rulings and constraints in defining DR functions. For example, only voluntary customer participation, without monetary compensation, is possible without PUC approval.
- PV system (monitored only). 26 PV installations were initially identified in the Maui Meadows subdivision. The number of systems is now over 100 and more continue to be installed. The project will seek to monitor the output of as many of these as possible.
- MECO-owned battery (vendor proposal evaluation process was completed for an approximate 1 MW/1.2 MWh sized battery).
- Monitoring of system and feeder conditions, including voltage and current sensors, feeder load, customer premise metering, and wind farm and PV output. This will include supporting a feeder model that will be updated and calibrated in real time, enabling the MECO system operator to conduct studies and to support specific Smart Grid applications (IVVC, DR Manager, and DER management including management of energy storage).

Task 2.3: Sizing and Specification of Distributed Energy Resources

This task will utilize the actual/projected load profile of the distribution system and the system models developed in Tasks 2.1 and 1.4 to finalize the nature, size, and location of the DER assets identified in Task 2.2. Progress continues in DMS design with integration meetings being held with HNEI, MECO, HECO, SSN, and Alstom; negotiations with customers (for DR and AMI) were conducted during Q3 and Q4 2011; procurement of battery energy storage system in the substation continued during 2012, and the vendor A123, shipped the battery to Maui in Q2 of 2013. Placement of sensors and communications was completed in Q1 of 2012. **These were documented in the final specification of DER resources delivered to DOE in Q1 2012.**

Task 2.4: Early Evaluation of Controls and Communication Design

During the 4th quarter of 2009 and the 1st quarter of 2010, the project team defined the initial requirements, functional specifications, and functional design for the communication and control system. This information was used to identify and evaluate potential vendor solutions for providing the communication and control platform for the project. **This task was completed in the 1st quarter of 2010.**

Task 3: Controls and Communication Design

The project team will use and update the system specifications described in Task 2.3 and the functional requirements (Task 1.5) to guide the development of the energy management, controls, and communication technologies needed for the DMS solution. The design task will augment the existing distribution feeder monitoring and management capability by adding:

- Selection and integration of SSN-based AMI architecture, featuring:
 - Bi-directional communication (between the utility and customers);
 - Direct load reduction capability (primarily HVAC and water heaters);
 - Use of customer electricity pricing information and potential time-of-use rates; and
 - Meter data collection, trending and reporting.
- A framework for distribution system dispatch of DER, covering generation, storage, and loads.

- Display of DER to the MECO system operation, providing for future operator dispatch or scheduling of DER to address grid needs of:
 - Providing up-reserve;
 - Providing down reserve at night (less renewable energy curtailment);
 - Load-shifting with storage;
 - Obtaining visibility of PV output to understand net load and manage voltage;
 - Fast-acting DR to mitigate decreases in as-available generation; and
 - Alerting the operator to voltage events driven by PV drop-off.

This task is complete. The project team is documenting the analysis plan and performance evaluation as part of the final reporting (Tasks 9 and 10), based on data collection and the exercise of controls during the performance period (Task 3.4).

Task 3.1: AMI and Communications Architecture Definition

In this task, the AMI architecture will be reviewed and further refined, considering Functional Requirements Specifications developed in Task 1.5. A communications architecture interfacing the DMS controller and the DER inside the feeder will be determined. The communications interface between the DMS controller and relevant external entities (including the utility) will also be defined. This task was completed in Q2 of 2011. It will support:

- Real time feeder monitoring for the DMS through extension of the MECO SCADA and integration of the DMS with the SCADA;
- Initial development of DMS applications; and
- AMI or “smart” meter installation: several AMI solutions are being considered and their pros and cons are analyzed.

During 2010, the team analyzed the pros and cons of several AMI options and selected Silver Spring Networks as the AMI supplier. Final prices and specifications of features were completed by the end of the second quarter of 2011. The FAT was conducted for the AMI communication equipment, meter interface, demand response equipment, and DA equipment at the end of Q2 2011. The final contract negotiations with SSN were completed in Q3 2011 and equipment was ordered. SSN performed site surveys in Q4 2011 and installed back office software applications during this period. AMI communications equipment was installed in Q1 – Q3 of 2012. **This overall task was completed in Q1 of 2012.**

Task 3.2: Distribution System Control and Energy Management Design

Guided by the Functional Requirements Specification developed in Task 1.5, as well as specific feedback from the TRC, the project team is designing the dispatch algorithms that coordinate the operation of DER, including all distributed generation, energy storage, and demand response functions. This task will also develop the necessary control functions that make it possible for the utility to dynamically control the power exchange over the connection of the substation to the grid, allowing for grid support services such as augmenting reserves and ramp-rate assist. Validation of these algorithms in a simulation environment utilizing different system models and monitored feeder and system data will also be performed as part of this task.

Alstom Grid was selected to supply the DMS. During Q1 through Q3 of 2012, the project team worked to integrate the monitoring and control strategies and exchanges between the Alstom DMS and the SSN AMI and demand response systems. To support this integration activity, the data flow diagrams for each function (originally developed in Task 1.6) were updated in Q2, Q3,

and Q4 of 2012 and underwent a project team review before submission to DOE. (The team chose Alstom because of continued concerns over the original vendor's ability to meet the project schedule within the projected budget. The project team evaluated several vendors and the Alstom DMS was particularly attractive because it required less effort to integrate with MECO's existing systems. MECO currently has an Areva/Alstom SCADA system and was already in negotiations with Alstom to upgrade it. The Alstom DMS can more easily integrate with MECO's SCADA system. NETL requested a report on the DMS vendor selection process and evaluation criteria; this was delivered to NETL and DOE in early Q3 2012.)

This task is complete: In Q1 of 2013 the project team continued to work on the integration of the DMS functions with the SSN AMI and DR systems and the MECO SCADA system. This includes implementing a real-time feeder monitoring capability to be input to the DMS to support the distribution load flow models of the DMS. The feeder load flow model and the voltage control function have had to be augmented because the increase in the number of PV installations means the feeder, as a whole, is expected to occasionally become a net generator of electricity by the end of the performance test period. Much of the activity during Q1 of 2013 involved exercising and testing each DMS function's interface with the AMI system. By early Q2 of 2013, the command structure (DMS commands to AMI for monitoring and control) had been established and the DMS was successfully obtaining data from the AMI system. In Q3 of 2013 the utility continued to exercise the RDSI functions and the HNEI project team assembled performance data. Metering data (household load and PV output), feeder voltage and current data, and appliance load data have been collected Q3 – Q4 2013 and Q1 – Q3 2014. DR dispatch schedules were developed in Q1 2014 and implemented Q2 – Q3 2014; data from these operations are being collected and analyzed. In Q1 – Q3 2014 BESS was dispatched to reduce peak load and to improve reactive power management and voltage support.

Task 3.3: Model-Based Validation

The following model-based simulations were used to verify that the functionality of the control algorithms developed in Task 3.2 satisfies the design intent:

- The distribution system model developed in Task 2.1 will be utilized to validate the functionality of the dispatch algorithms. The model will be further utilized to identify the dynamic capability of the aggregate dispatch approach, and to perform a preliminary benefits assessment of the use of the DER selected for the project.
- Analytical models can also be developed to estimate how the DER can enable MECO to support larger quantities of wind and distributed PV on its system and can be further utilized to evaluate the performance of the proposed project.

This task was further defined and the schedule given, in a detailed system performance test plan and experiment protocol developed, as a preliminary draft, in Q1 2012 (see Task 5.1). The project team included data collection and model validation in its performance period test plan, which was submitted to DOE in Q3 of 2013. **This task is complete.** However, as the systems are operated and data are collected, the project team (HNEI and MECO) will update the analysis-based models in the future, after project completion.

Task 3.4: Control System Tuning

The models developed in the prior task were exercised to tune the DMS controller parameters in order to maximize the performance benefits and minimize operating costs.

This task was part of the detailed system performance test plan and experiment protocol developed, as a preliminary draft, in Q1 2012. The project team continued to update the test plan and schedule with MECO operations through Q2 2014. Changes to the test protocol have been made to reflect exactly how the DMS and AMI systems will interface, including accounting for latency in commands and “reads,” and to modify the DR and BESS dispatch based on results of initial dispatch protocols. To better obtain data on individual controllable appliance load profiles and response to Demand Response commands, HNEI purchased some additional load sensors and data loggers. In Q3 of 2013 the participating homes for these sensors were identified, and the sensors were installed in 5 homes in the subdivision to augment the whole house loads being monitored by the eGauge online program. **This task is complete.** The final reports on performance period test protocol and the analytics will be submitted to DOE in Q4 of 2014.

Task 3.5: Define Interfaces between the DER Assets and the Control System

This subtask will define the interface requirements and capabilities between the dispatchable distribution system controller and the dispersed DER assets. This will help define the communication protocols and capabilities in the later subtasks. This effort is nearly complete. It entailed several meetings and teleconferences among SSN, Alstom, MECO, and HNEI to define the interfaces. An updated set of data flow diagrams was completed in Q2 2012 to specify many of these interfaces. This task was completed in Q4 2012 except for some details of integration with the BESS. Since the BESS was installed in Q2 of 2013, the interface between the BESS and the other DER and the DMS has been clarified, and **the task is complete.**

Task 4: Detailed Design and Implementation

The site acceptance test for the DMS and integrated RDSI system was **completed in June, 2013.**

Task 4.1: Detailed Energy Management and Control Design

In this subtask, a field-deployable DMS control platform will be developed based on the energy management and control algorithms developed and model-tested in Task 3. These functions will be implemented on the final DMS platform selected for the project. Monitoring of the MECO feeder and interfacing it to the remote DMS will further enable this task. Meter reprogramming issues and delays in installation of some of the DMS hardware have extended this task but problems have been resolved. Much of the integration between the SSN AMI headend and DRMS with the Alstom DMS was completed in Q4 of 2012 in conjunction with the FAT for the DMS. The remainder was completed as the DMS was shipped and installed on Maui in preparation for the DMS site acceptance test. **With the installation and operation of the BESS in Q2-Q3 2013, this task is complete.**

Task 4.2: Detailed AMI and Communication Architecture Design

The project team will also perform a detailed design of the AMI and communications architecture needed for the DMS solution, and will develop the functionality into the selected meter and communication platforms. MECO will have final approval of this design due to considerations of utility operations and communication protocols, security, and compatibility with existing and planned utility equipment and software. In particular, cyber-security compatibility requirements are being addressed through ongoing discussions between the project team and the utility’s (both MECO and HECO) cyber-security experts. During the fourth quarter of 2011, Silver Spring Networks conducted a site survey and signal survey of the demonstration area to determine the exact quantities and location of communication equipment. The detailed

AMI architecture document was prepared in Q1 2012. The AMI communication equipment was installed by SSN during 2012. **This task is complete.**

Task 5: Validation Testing

The energy management controls and communication platforms developed in Task 4 were field tested at the DMS vendor's test facility (in Washington) during Q4 2012 and Q1 2013. Remote links to SSN's metering data bases (in California) were established for this. MECO SCADA data were either transferred by flat file or through a secure communications link. This will ensure that the products will cope well with variations (sometimes unpredictable) in its operating environment with minimal damage, alteration or loss of functionality. An enhanced factory acceptance test was designed with MECO and HECO to certify the DMS is ready for installation on Maui. FAT for the Alstom DMS system occurred during Q4 2012 and Site Acceptance Testing (SAT) was completed in Q2 2013. **With the installation of BESS in Q2 2013, this task is complete.**

Task 5.1: Define Test Objectives and Test Plan

Work on this task was begun in Q3 of 2010 and draft test plans were submitted to MECO for their review in Q1 of 2012. The project team continues to work closely with MECO operators to update test objectives, performance criteria, and test protocol. A factory acceptance test plan was developed outlining the specific validation and verification test vectors that the hardware and software will be subjected to. The performance period test plan includes evaluation of the following functional features:

- Effective and secure communications between MECO's EMS and DMS;
- Dispatch of DG and energy storage assets under diverse simulated grid operating scenarios (i.e., high-loading, congestion, voltage sags, etc.);
- Servicing simulated grid power exchange requests from the utility, e.g., set-point changes, ramp-rate constraints, and power-frequency control;
- Maintaining voltage and current profiles along the feeder within limits;
- Monitoring "end of line" voltage at selected customer sites;
- Proposing VVC actions to maintain voltages within limits;
- Maintaining the current feeder configuration model;
- Updating the feeder load flow model using monitored data;
- Displaying aggregated PV output from multiple sources along the feeder;
- Dispatch of direct demand response requests, and the propagation of those requests through the AMI network;
- Dissemination of energy pricing signals through the AMI infrastructure; and
- Meter data collection, aggregation and reporting by the dispatchable distribution system controller.

A report summarizing the test objectives and the test plan (i.e., protocol for the performance period) was completed in Q4 of 2012. Factory Acceptance tests were defined and conducted on the SSN communication equipment, meters, and in-home devices, PV monitoring, and feeder current monitoring during Q2 2011. During the fourth quarter of 2011 and the first quarter of 2012, the FAT tests objectives were defined for the DMS system. The FAT for the DMS was conducted during 4Q 2012. The final test plan for the performance period was completed in Q4 of 2012 and was submitted to DOE in Q2 of 2013. **This task is complete.** As part of Task 9 (and documented in the final technical report of Task 10), the performance period test protocol and

associated analytics plan were updated by the project team during Q1 – Q2 2014 as integration and operation of the subsystems (AMI, DR, DMS, SCADA, BESS, etc.) continued.

Task 5.2: Adapt Control and Communication Infrastructure at Test Sites

The DMS vendor's facilities will be utilized to test the energy management, controls, and communication infrastructure needed for fulfillment of the test plan outlined in Task 5.1. The DMS FAT was conducted during Q4 2012 and the DMS SAT was conducted in May and June of 2013. **This task is complete.**

Task 5.3: Testing

The project team performed pilot testing of the energy management and controls hardware, carrying out the test plan detailed in Task 5.1. The DMS FAT was conducted during Q4 2012. Reports summarizing the FAT and SAT (site installation) testing and test results/conclusions were submitted to DOE in 2013. The Test plan of Task 5.1 describes the operations and test schedule for the system through installation and the 1-year performance test. The performance test period is Q3 2013 – Q3 2014. **This task is complete.**

Task 6: Wailea Substation Site Preparation and Feeder Selection

In 2010, the project team selected circuits 1517 and 1518 from the Wailea substation to be used for the demonstration phase. The Environmental Questionnaire has been completed for the new Wailea substation site and a Categorical Exclusion has been granted by NEPA. In Q1 2012, the project team started preparing the subtasks within Task 6. The task reports were submitted to DOE in Q3 2013. **This task is complete.**

Phase 2 – Demonstration on Maui

Task 7: Build/Modify Substation and Procure Equipment

This task will require successful completion of previous tasks; in particular, successful completion of the Maui design (Task 4) and the Factory Acceptance Testing of the DMS (Task 5.3), and completion of NEPA evaluations (Task 6.2). To meet the project schedule, a phased procurement and build/install strategy will be used. This work task includes all activities associated with procurement of proposed technologies for the overall project. **This task is complete, and a list of all equipment installed was submitted to DOE in Q4 2013.**

Task 8: Installation of Technologies and Commissioning

Installation of equipment including distributed generation, energy storage devices, and AMI meters will be executed through separate contracts with one or more EPC (engineer, procure, construct) providers. The selected AMI and DR vendor is SSN. The selected DMS vendor is Alstom. The selected installation contractor is HNU Energy. Under supervision of HNEI and MECO, these contractors will install and commission the distribution management system, AMI, and demand-response elements. With the installation of the BESS in Q2 2013, this task is complete. The Site Acceptance Test (SAT) reports were submitted to DOE in Q4 2013. **This task is complete.**

Task 9: Testing and Demonstration

The focus of this task will be on-site validation and verification tests to fully explore the peak load reduction and other operational objectives at the selected substation. All the key performance parameters have been defined in the Analysis and Test Plan (Task 5.1 and 9.2); they

will be tracked and recommendations will be made based on field experience. In the final phase, two reports will be written summarizing the field performance. One report will be for public release. The other will contain proprietary information, such as customer-specific load data, that may not be released outside of DOE and the key participants of this project. The final report will include the design and test documentation according to DOE guidelines.

Task 9.1: Define Test Objectives

Draft Test Objectives were completed during Q1 2012 and used for the development of the test plan (Task 9.2).

Task 9.2: Develop test plan

A Draft Test Plan was developed during Q1 2012 and completed review by the project team in Q4 2012. It was submitted to DOE in Q1 2014 after being modified to be consistent with system operating constraints due to data latency, response time, and timing of joint AMI/DMS operation. The need for modifications to the test plan was apparent during the systems integration work of Q1- Q2 2013. As the system operates, and performance data are collected and analyzed, the test and analysis plan continued to be updated. The final plan, reflecting actual test activity, will be submitted to DOE in Q4 2014 and will be **summarized in the Final Report (Task 10)**.

Task 9.3: Perform Testing and Monitoring

Once the successful operation of the distribution management system on the proposed demonstration circuit(s) has been validated, it was expected that HNEI, in collaboration with the NETL-designated data analysis team (DAT), would initiate the collection of key data elements that shall be used to analyze system performance and develop cost and benefit analyses. A metrics and benefits plan and report (MBR) were submitted to NETL and its DAT. This included such data elements as:

- Daily on/off peak demand served by DG and the storage units;
- Daily demand reduction from implemented DR program(s);
- Reliability and service quality improvements as observed in feeder voltage profiles and outage occurrences (including duration of outages);
- Customer control actions enabled by the system that reduce energy bills and/or improve comfort, and circuit improvements impacted specifically by the system and microgrid operation (including dynamic islanding);
- Improvement on all circuits (i.e., feeders) served by peak load management system; and
- DG, Energy Storage, and control/monitoring system operation and maintenance (O&M) costs (including fuel and reserve support requirements as appropriate).

HNEI felt that the initial MBR needed to be modified to define performance and system characterization metrics for this project that are suitable for a research and demonstration project, rather than a full-scale system implementation. In addition, to meet DOE's and MECO's needs, the project, while limited in scope and research-and-development-oriented, must still be expandable (additional functions and capabilities), scalable (additional substations and feeders),

and replicable (relevant to other utilities, especially mainland utilities, and able to incorporate legacy systems).

These data were to be used to develop cost and benefit analyses by comparing the baseline performance of the selected circuit prior to the demonstration phase with the performance of the same circuit during the pilot demonstration. The intent was that the project team would share all data resulting from the demonstration with the DOE-designated RDSI data analysis team (DAT) to enable the team to conduct a cost and benefit analysis using the jointly developed consistent methodology.

During the fourth quarter of 2010 a draft Metrics and Benefits Reporting Plan (MBRP) was submitted to NETL. A revised MBRP, incorporating comments and suggestion from NETL, was submitted in Q1 of 2011. This plan was approved in Q3 2011.

In Q2 of 2012, NETL informed HNEI that it was re-defining the templates and procedures for the MBR and data reporting. The project team continued to address the intent of the MBR with the development of a data analytics plan (completed in Q4 2012 and continuing to be updated and refined as data were collected and analyzed) and the establishment of a project data warehouse at University of Hawaii. This task continued through the performance period. After initial meter, PV, feeder and eGauge data were collected in Q3 – Q4 2013, initial demand response control schedules were developed, and these were implemented early in 2014. HNEI also worked with MECO and HECO to dispatch BESS and observe the effects on feeder voltage and peak load. In Q3 and Q4 2013, the initial data to estimate Maui Meadows home load profiles and PV output profiles were been collected. These data were analyzed in Q1 – Q2 2014, and that analysis is continuing in Q3 – Q4 2014. Initial analysis of the collected performance data was used to modify the demand response commands and the dispatch of other assets (BESS, tap changer positions). **With the end of the performance testing (mid-September 2014), this task is complete. Results will be documented in the selected Technical Progress Reports and the Final Report, submitted to DOE in Q4 2014.**

Task 9.4: Demonstrate to Customers and Stakeholders

HNEI, in partnership with SSN, has continued discussions with MECO staff and management as well as other community partners about how to best develop good relationships with their customers as part of this project. While this is appropriately a demonstration task, a considerable amount of groundwork needs to be done to ensure that the utility customers are supportive of what is being done in the project.

The project team has continued to make good progress in this area. In collaboration with the Maui Economic Development Board (MEDB) and County of Maui, the project team developed a project website, sent letters to community members to recruit project volunteers, held or attended several community and Maui County-sponsored outreach events, and received considerable coverage about the project in local media. The team also briefed local elected officials about the plans for the project. Through these efforts, we have recruited over 80 volunteers. The outreach efforts continued through the project. In Q4 of 2012 two outreach meetings with project participants were held. Another outreach meeting was held in Q1 2013. MEDB continued to lead participant outreach and communications activities throughout the rest of the project.

A key Q3 activity was the completion of the customer survey by Sustainable Living Institute of Maui (SLIM) of the University of Hawaii Maui College (UHMC). (This report was submitted to

DOE in Q4 2013.) A chronic problem with “smart grid” rollouts in the U.S. has been lack of customer acceptance, often due to inadequate communications and education of the consumers as well as poor matches between smart grid functions and capabilities and consumer needs or desires. From the start, the Maui RDSI project implemented a robust customer outreach program, characterized by numerous meetings with Maui Meadows residents, an informative website, customer service and “help” assistance, offers of energy audits, and pre-and post-installation interviews and surveys. The objectives of this customer outreach effort were to:

- Ensure that participants understood and could use the information and functions made available to them in the RDSI pilot project
- Identify and correct any problems or “bugs” in the functions before any system-wide smart grid, advanced metering (AMI), or demand response (DR) system was specified and procured
- Determine the value to the utility, the consumers, and the community of the candidate “smart grid” functions being piloted in the RDSI project
- Develop the requirements and specification for system-wide rollout of any “smart grid” functions
- Help consumers reduce their energy costs and, in doing so, inform the utilities, Public Utility Commission, local governments, and non-government organizations in their formulation of energy policies and goals
- Train local workforce for energy-related jobs. (This is especially appropriate because much of the DOE sponsorship of the RDSI project was ARRA-funded.)

The SLIM activities have been extremely successful in achieving these objectives. They will provide direction for MECO, HECO and HELCO to move forward with their smart grid programs in a manner that most benefits the customer. HNEI feels that the customer outreach methodology and the lessons learned from the customer communications are also broadly applicable to mainland utilities beginning to design smart grid programs.

A final outreach meeting was held in Q3 2014, and customer follow-up and debriefs were conducted by SLIM in conjunction with removing in-home equipment after the performance period ended. The results of this task include Technical Reports by SLIM / HNEI, as well as documentation in the final report. **This task is complete for execution of the activity.**

Documentation will be completed under Task 10.

Task 10: Project Management and Reporting

This task includes administration, management and supervision of all aspects of the proposed project. Reports and other deliverables will be provided in accordance with DOE guidelines. This task will occur concurrently with previously described tasks, and will culminate within ninety days following Award expiration. The contract between HNEI and DOE/NETL was signed in December 2008. Following the development of this contract, additional contracts were developed in the first quarter of FY09 between HNEI and Sentech and GEGRC.

On February 10th and 11th of 2010, the Technical Review Committee (TRC) met. The committee reviewed current work products and made recommendations for improvements in project direction. The report on this meeting was delivered to NETL in April 2010. Members of the TRC are:

- Joe Eto, Lawrence Berkeley National Laboratory;
- Steve Pullins, Horizon Energy Group;

- Dan Partridge, PG&E;
- Ron Hofmann, independent consultant and TRC Chair;
- Neal Shinyama, MECO (ret.);
- Leon Roose, HECO [now with HNEI]; and
- Jose Dizon, HELCO.

HNEI consulted with NETL and DOE about the future role of the TRC, and no additional meetings were scheduled. The project team met again in October 2010 with the product team from General Electric's GENE subsidiary. In these meetings, the team discussed the compatibility of the GENE DMS with the project objectives and the level of effort required for the development of new Smart Grid functions on this system. Due to GE's inability to meet the functional, schedule, and budget requirements of the project, the project team elected to evaluate other DMS vendors (NETL requested a report on the reasons for selecting an alternate DMS vendor. HNEI submitted the requested report in 2013.)

Project reports and deliverables were updated with the selection of SSN as the communication, DR, and AMI provider, the selection of the BESS vendor, and Alstom as the DMS vendor.

HNEI worked with NETL's DAT to provide project reports required for American Recovery and Reinvestment Act of 2009 (ARRA) funding. The initial Metrics Reporting and Data Plan template was delivered in November 2010. A project presentation was delivered for the RDSI Peer Review in Denver, in November 2010. After receiving comments from NETL, a final Metrics and Benefits Data Reporting Plan was submitted to NETL in Q1 2011. The first – baseline – MBR was submitted to NETL in Q1 of 2012. Since then DOE has suspended activity using the MBR templates; however, HNEI and the project team are continuing to collect and analyze data according to the project test protocol and analytics plan completed in Q4 of 2012. A project data warehouse has been established at the University of Hawaii. HNEI continues to report ARRA-required information to DOE. As with other DOE ARRA-funded demonstration projects, HNEI has met the DOE/NETL metrics and benefits reporting requirements by preparing Technical Progress Reports and will prepare a Final Report.

HNEI presented the project at the DOE program peer review in San Diego, CA June 7 – 8, 2012.

A Final Report, additional Technical Progress Reports, and an end of project debrief / presentation for DOE will be submitted in Q4 2014.

Task 10.1: Revise the Project Management Plan (PMP)

The PMP was revised for the Budget Period 2 expenditure authorization request. The revised PMP and revisions to the SOPO, Budget Justification and Budget were submitted to NETL in April 2010. The authorization to expend Budget Period #2 funds was received from NETL in June 2010. As a result, amended contracts that reflect the use of ARRA funds during this period were developed with Sentech. An updated PMP and SOPO were prepared for the start of budget Period 3 (2Q 2011). HNEI updated the PMP again in support of the request to modify the award by including a new DMS vendor. Due to delays in installation of the DMS hardware and the BESS, plus the time needed to address the meter programming issues, a further PMP and schedule update, with a request for a no-cost time extension, was submitted to NETL in Q3 2012. **That submission completed this task.** The final report includes a summary of the final PMP and schedule, reflecting the actual equipment delivery, installation, and testing, as well as the exercise of the BESS, AMI, DMS and DR systems.

Task 10.2: Establish Baseline Performance

HNEI has identified and began collecting baseline performance data in late 2012. The project team is continued to collect baseline performance data as well as function performance data during the demonstration phase. University of Hawaii established a data warehouse to centralize all data needed for RDSI performance analyses. Baseline performance data will be presented in Technical Progress Reports and the Final Report.

C. Schedule Status – Deliverables

Deliverable due dates will be modified, as appropriate, in the revised Project Management Plan.

Task 1: Report on selected Substation and feeder, and the DMS functional requirements. This report was delivered in January 2010.

Task 2: Proposed list of DG assets including their initial sizing.

Updated but still preliminary estimates were reported in the 2010 Q2 progress report, and were finalized at the end of Q4 2011. Report prepared January 2012.

Task 3.3: Report describing control specification, design and simulation results – prepared December 2011.

Task 4.2: Report on final communication architecture – prepared January 2012.

Task 5: Report summarizing the factory acceptance test plan, testing and results/conclusions – AMI, DRMS, PV monitoring, DA, and HAN FAT report delivered in July 2011. DMS report will be delivered in Q1 2013, documenting the completion of DMS FAT in Q4 2012.

Task 6.1: Report summarizing the evaluation of candidate sites and the selection rationale – report prepared January 2012

Task 6.2: Report on the status of construction, environmental and other permits. CX has been provided by the DOE.

Task 7: List of equipment/services to be procured and their specifications and cost. Copies of purchase requisitions for major equipment (transformers, circuit breakers, etc.) will be included. These reports were submitted to DOE/NETL in Q4 2013, since the remaining in-home equipment was installed in Q3 2013.

Task 8: Report on installation and commissioning procedures. AMI site acceptance test was completed in Q4 2012. DMS site acceptance test was completed in Q2 2013. The site Acceptance Test report was submitted to DOE in Q4 2013.

Task 9: Report on test results at the project site are scheduled to be submitted Q4 2014.

Task 9.4: Site visit and demonstration with DOE and key participants – as requested by DOE.

Task 10.1: Project Management Plan and updates:

- Initial update was due and submitted within 90 days of the effective date of the Award,
- 2nd update was due and submitted 30 days prior to the scheduled start of Phase 2, and

- Interim updates will be provided as major modifications occur. With the completion of equipment installation and SATs, the final PMP and schedule will be included in the final report to be submitted to DOE in Q 2014.

Task 10.2: Cost and Benefit Analysis:

- Baseline – originally due in accordance with guidelines established jointly with the DAT. This now is part of the analysis described in the analysis and test plan (Task 9.2) , and
- Final – will be included in the final report for the project.

D. Reports, Briefings, and Technical Presentations

Periodic detailed briefings will be presented to the Project Officer at the Project Officer’s facility located in Pittsburgh, PA; Morgantown, WV; Washington, DC, or other mutually agreeable site to explain the plans, progress and results of the effort. The first briefing was presented at Red Bank, NJ on October 25, 2008 as part of an overall annual review conducted by the Office of Electricity. The next briefing took place in the US DOE RDSI Program Review, day-2 (September 18, 2009) of the Symposium on Microgrids at San Diego. The project team also participated in the Navigant webcast and the ARRA documentation reviews in April and May, 2010. The team attended and presented at the DOE Peer Review meeting in Golden, CO in November 2010. The team attended the Smart Grid R&D Program 2012 Peer Review held in San Diego June 6-8, 2012. Additional briefings will be given as requested by NETL and DOE project management, with a final briefing occurring in conjunction with the completion of each Phase. A final Phase 2 and project briefing will be presented to DOE when requested.

E. Products Produced or Technology Transfer Activities Accomplished During Project closeout (Q3 – Q4 2014)

HNEI continued to publicize the project in Hawaii, kept the project website current, and continued to add to the project data being warehoused at University of Hawaii. The project data continue to be collected and analyzed. An outreach meeting for interested Maui residents was held in Q3 2014. A Final Report will be submitted to DOE in December 2014.

F. Cost Status

The table below presents project spending.

Project Spending

Quarter	From	To	Actual Federal Share of Outlays*	Actual Recipient Share of Outlays	Cumulative
4Q08	10/1/2008	12/31/2008	0	0	0
1Q09	01/01/09	3/31/2009	1,122	0	1,122
2Q09	4/1/2009	6/30/2009	195,504	14,426	211,052
3Q09	7/1/2009	9/30/2009	161,629	0	372,681
4Q09	10/1/2009	12/31/2009	96,336	0	469,017
1Q10	1/1/2010	3/31/2010	436,707	56,345	962,069
2Q10	4/1/2010	6/30/2010	140,916	186,166	1,289,151
3Q10	7/1/2010	9/30/2010	38,102	0	1,327,253
4Q10	10/1/2010	12/31/2010	55,586	113,907	1,496,746
1Q11	1/1/2011	3/31/2011	24,055	0	1,520,801
2Q11*	4/1/2011	6/30/2011	21,186	28,733	1,570,720
3Q11	7/1/2011	9/30/2011	223,565	19,075	1,813,360
4Q11	10/1/2011	12/31/2011	248,627	17,282	2,079,269
1Q12	1/1/2012	3/31/2012	202,317	0	2,281,586
2Q12	4/1/2012	6/30/2012	148,815	2,981,085	5,411,486
3Q12	7/1/2012	9/30/2012	1,011,994.00	0	6,423,480
4Q12	10/1/2012	12/31/2012	87,649	0	6,511,129
1Q13	1/1/2013	3/31/2013	752,356.82	0	7,263,486
2Q13	4/1/2013	6/30/2013	225,989.26	117,865	7,607,340
3Q13	7/1/2013	9/30/2013	443,189.00	0	8,050,529.00
4Q13	10/1/2013	12/31/2013	1,013,173.60	0	9,063,702.60
1Q14	1/1/2014	3/31/2014	127,292.50	3,853,116	13,044,111.10
2Q14	4/1/2014	6/30/2014	229,070.00	0	13,273,181.10
3Q14	7/1/2014	9/30/2014	1,109,799.00	0	14,382,980.10
Totals			\$ 6,994,980.18	\$ 7,388,000	\$ 14,382,980.18

Appendix 2

Equipment and Software Procured for Maui Smart Grid Demonstration Project

A2.1 Introduction Project Overview

The Maui Smart Grid Project will develop and demonstrate a Distribution Management System (DMS) that aggregates distributed generation (DG), energy storage, and demand response technologies in a distribution system to achieve both distribution and transmission-level benefits. The application of these new technologies and procedures in a DMS will increase reliability and improve power quality along with reducing costs to both the utility and its customers.

The project will be demonstrating new technologies in the Wailea area of South Maui. Specifically, the team is working at locations served by two distribution circuits fed by a transformer at Maui Electric Company's (MECO) Wailea substation. Figure illustrates the project location in greater detail.

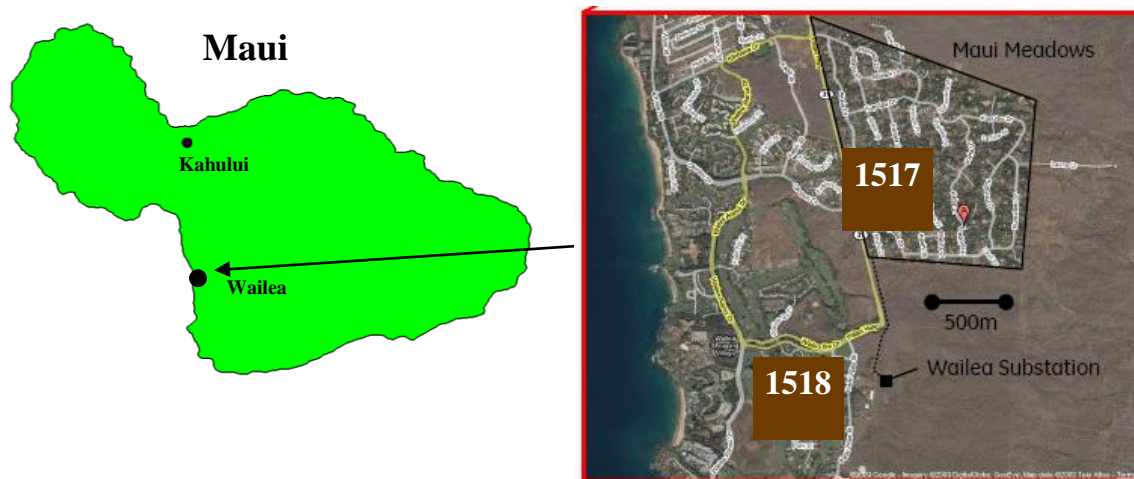

Figure A2-1: Overview of Maui and Project Location

The two distribution circuits (#'s 1517 and 1518) serve two different portions of the South Maui service territory. Circuit 1517 runs north from the Wailea substation and serves the Maui Meadows neighborhood. This is a relatively large residential subdivision consisting of primarily single family homes. Maui Meadows is the target neighborhood for demonstrating the residential Advanced Metering Infrastructure (AMI), Demand Response (DR), and photovoltaic (PV) monitoring aspects of the project.

Circuit 1518 primarily serves commercial customers in the resort areas of Wailea and Makena. These customers include most of the major resorts in this area, retail development, and condominiums associated with the resorts. The project team intends to find a limited number of commercial customers interested in participating in the project.

A2.2 Functional System Architecture

Figure A2-2 presents the overall architecture of the system. The diagram also represents the quantities procured and a functional representation of where the equipment resides within the overall project architecture.

A2.3 Procured Equipment

Figure A2-3 presents the list of equipment and quantities procured to support the HNEI Maui Smart Grid project. Detailed specifications for each piece of equipment were presented in the Task 7 report submitted to DOE (*Maui Smart Grid Demonstration Project: Procured Equipment and Equipment Specifications*, Task 7 Report under Award No. DE-FC26-08NT02871, University of Hawaii, Hawaii Natural Energy Institute, September 2013.)

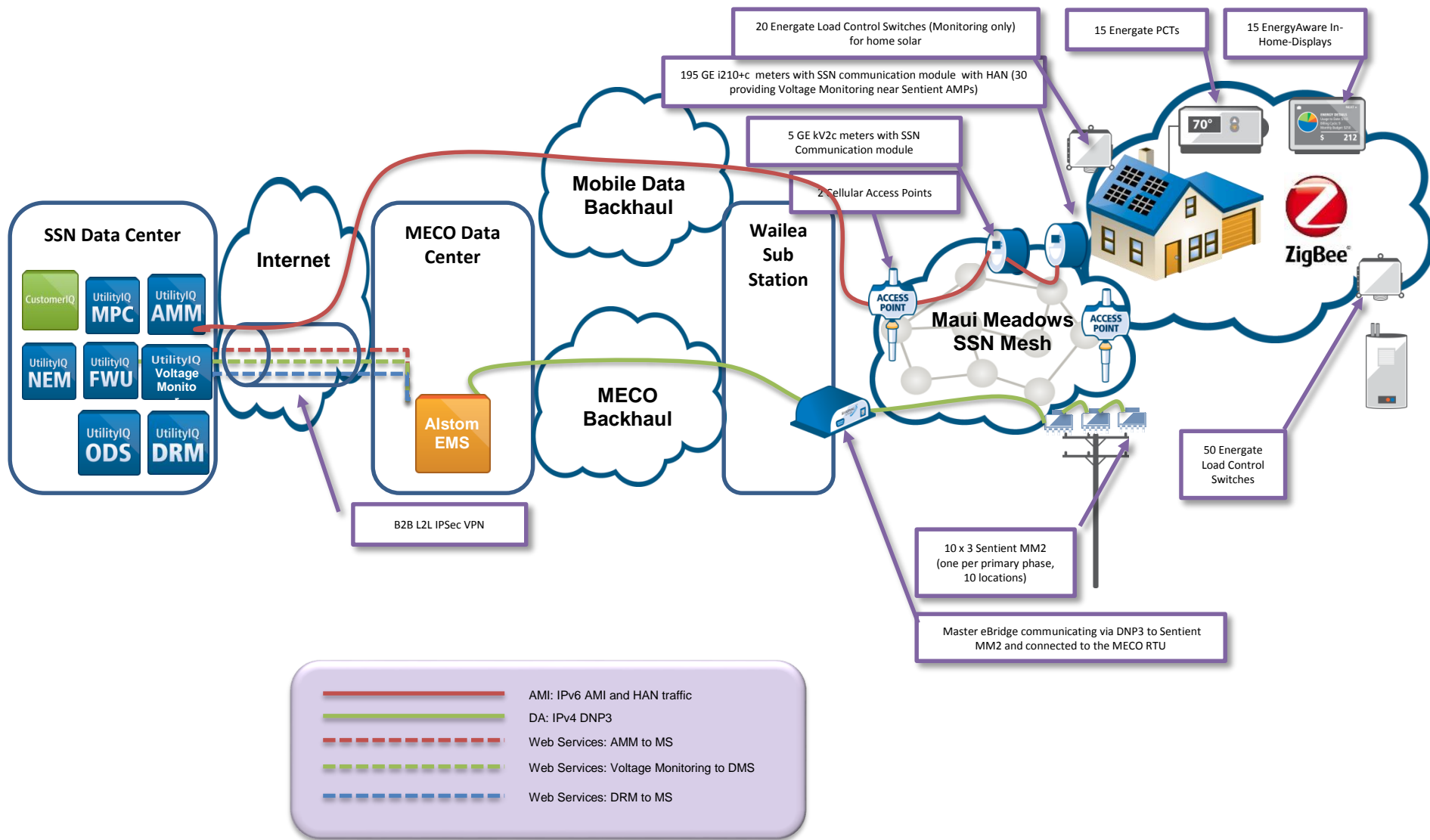

Figure A2-2: MECO Smart Grid functional Depiction

Equipment	Vendor / Manufacturer	Model Number	Description	Quantity
Communication Equipment				
Access Points	Silver Spring Networks		Central link between endpoint devices and network control and monitoring	2
Relays	Silver Spring Networks		Extends network reach to more customers	10
Data eBridge	Silver Spring Networks		Communicates data from feeder current sensors to RTU at Wailea substation	10
In- Home Equipment				
Meter Network Interface Cards	Silver Spring Networks		Allows meter to communicate with SSN network	200
Residential Smart Meter	GE	i210+c	Smart meter for residential use. Includes SSN NIC Card	195
Commercial Smart Meter	GE	kV2c	Smart meter for residential use. Includes SSN NIC Card	5
Load Control Switches	Energate	LC301	PV monitoring	20
Load Control Switches	Energate	LC301	Water Heater Monitoring & Control	50
Programmable Thermostats	Energate	Pioneer Z100 PCT	Enable signals and control of forced air systems	15
In Home Displays	EnergyAware	Power Tab	Enable whole home energy usage information to be retrieved from meters	15
Homeplug 1.0 w/ turbo wall adapter, 5' ethernet cable	eGUAGE		The HomePlug adapter converts the power-line signal back to a standard Ethernet plug, which can then be connected to LAN's router/ Ethernet switch	5
Main unit w/ 2yr Warranty, 5 pin plug	eGUAGE	EG301x	It measures electric power, records up to 30 years of data in its internal memory, and makes the data available	5
Split Core CT 100A/0.75"	eGUAGE		Clipped over wire of appliance to measure the amount of current flowing . Appliance data collection	10
Split Core CT 50A/0.40"	eGUAGE		Clipped over wire of appliance to measure the amount of current flowing. Appliance data collection	30
Split Core CT 40A/0.40"	eGUAGE		Clipped over wire of appliance to measure the amount of current flowing. Appliance data collection	20
Feeder Equipment				
Feeder Current Sensors	Sentient	AMP MM2	Captures feeder current on each phase	30
Software as a Service				
Customer IQ	Silver Spring Networks		Purchased as a Software as a Service	1
Utility IQ	Silver Spring Networks		Purchased as a Software as a Service	1

Equipment	Vendor / Manufacturer	Model Number	Description	Quantity
Distribution Management System				
SCADA Module	Alstom		Collect real-time data from remote terminal units and other communication sources in the field. For the Maui Smart Grid Project, the SCADA module will be extracting SCADA data from the “operational” MECO SCADA system	1
Network Analysis	Alstom		Real-time power flow for the entire network	1
Switching Application	Alstom		Switching procedures into the network management environment and is a key module that expands the operations of the Network View to support the process of switching on the network	1
Network View	Alstom		The Network Operations UI enables the user to maintain a high-level of situational awareness (SA) through its geographic and schematic views, while also enabling efficient access to distribution data and controls	1
DMS System Hardware	Alstom	e-Terra system	e-Terradistribution system hardware consists of the equipment listed below.	See below
HP DL380 Servers	HP	583914-B21	DMS Servers	3
HP Z400 Workstation	HP	VS933AV	DMS Workstaion	1
SmartPro 2.2kVA UPS	Tripp Lite	SMART2200 RMXI	Uninterruptable power supply for DMS servers	2
Rack enclosure	Tripp Lite	SR42UB	42U rack enclosure w/ sides and doors for DMS servers	1
PDU	Tripp Lite	PDUMV20	Power distribution unit for DMS servers	2
Server Rail Kit	HP	663478-B21	HP ball bearing Gen8 Rail Kit with CMA for DMS servers	3
Dell Latitude Laptop	Dell	E6430	DMS laptop – FAT testing	1
ADAM 6017	B&B Electronics	ADAM-6017-BE	Data Acquisition and Control Modules	1
DIN Rail Power Supply	B&B Electronics	PWR-242-AE	Power supply for data module	1
DIN Rail	B&B Electronics		Mounting rail for ADAM 6017 & power supply	1
Battery Energy Storage System				
Battery Energy Storage System	A123 (now NEC, by acquisition)	Custom configuration for MECO Wailea #25 Substation	Lithium Ion Nanophosphate based batteries & associated controls housed in a GBS (Grid Battery Storage) Container, 1.2 MWh 1MW Power Skid with integral Power Conversion System	1

Figure A2-3: Bill of Materials