

ELECTRODYNAMICS AT VERY LOW AND VERY HIGH ENERGIES

STANLEY J. BRODSKY

STANFORD LINEAR ACCELERATOR CENTER

STANFORD UNIVERSITY

AND

SCHOOL OF MATHEMATICAL AND PHYSICAL SCIENCES

UNIVERSITY OF SUSSEX

LECTURES, MAY AND JUNE 1971

I. INTRODUCTION

Our main focus in these lectures will be to trace the theoretical treatment of electromagnetic interactions - especially the Compton amplitude from very low to very high energies. We will especially note the similarities between the various techniques in the two domains. We shall emphasize physical aspects rather than unduly worry about rigour. The emphasis will be on current problems, and where further problem and research areas still lie.

We will especially try to understand the theoretical setting for the study of the hydrogenic atom. Since we will not want $m_e/M_p \rightarrow 0$ necessarily, the Bethe-Salpeter equation will be a basic tool. A simple physical derivation is given, including the main techniques used for actual calculations of the energy levels. The Lamb shift physics and derivations will also be discussed.

In the second part of the course we will discuss high energy aspects of field theoretic electrodynamics, and go on to consider problems concerning the nucleon itself, especially Compton scattering and inelastic electron scattering. We will briefly review the work of Cheng and Wu and others on eikonal techniques at high energy. We'll then go on to discuss the parton approach to electromagnetic interaction, as developed by Feynman, Bjorken and Paschos, and Drell, Yan, and Levy.

Some parts of these lectures are based on those given at Brandeis University in 1969 [Gordon and Breach, to be published, 1971]. Further information on the current status of Quantum Electrodynamics (QED) may be found in the review by S. Brodsky and S. D. Drell, Ann. Rev. Nucl. Science, 1971.

II. THE FREE ELECTRON VERTEX

One of the concepts which will recur most frequently in this course is that of the form factors for the one-photon vertex of the electron or muon.

Later we shall be interested in the case of the bound lepton, but for now consider the free lepton $p'^2 = p^2 = m^2$. Using parity and current conservation, the general form of the vertex is (see e. g., Bjorken and Drell, 1964).

$$\bar{u}(p') e \Gamma_\mu u(p) = e \bar{u}(p') \left[\gamma_\mu F_1(q^2) + \frac{i \sigma_{\mu\nu} q^\nu}{2m} F_2(q^2) \right] u(p) \quad (\text{II. 1})$$

By the definition of the unit of charge, $F_1(0) = 1$, and we identify $F_2(0) = a = (g-2)/2$ as the anomalous magnetic moment of the lepton, i. e. the part of the moment beyond that given by the Dirac equation. Note that the total vertex yields the interaction

$$-\frac{e}{2m} (1+a) \underline{S} \cdot \underline{H}$$

for the nonrelativistic electron in an external static magnetic field.

For the case of the proton, there are excellent measurements of F_1 and F_2 for $0.01 (\text{BeV})^2 < |q^2| < 25 (\text{BeV})^2$. but as yet no fundamental understanding of the results. For the case of the electron, QED, in principle, completely predicts the form factors.

For $|q^2| \ll m^2$ the second-order correction to the vertex from QED is

$$\Gamma_\mu = \gamma_\mu \left[1 + \frac{\alpha}{3\pi} \frac{q^2}{m^2} \left(\log \frac{m}{\lambda} - \frac{3}{8} \right) \right] + \frac{\alpha}{8\pi m} [\not{q}, \gamma_\mu] \quad (\text{II. 2})$$

which yields the Schwinger (1949) coefficient $a = \alpha/2\pi$.

We shall require the $F_1(q^2)$ part of Γ_μ in our Lamb-shift discussions. For now we note the following:

(1) A charge renormalization in the proper vertex graph is required to keep $F_1(0) = 1$. [This cancels against the wave function renormalization (improper vertex) diagrams] .

(2) $F_1(q^2)$ is infrared divergent for $q^2 \neq 0$, and a photon "mass" λ is required to keep the result finite. Of course, this dependence on λ cancels out when one calculates the electron scattering event rate for an actual experiment. At order α one must include in the calculation of the rate the cross section for scattering plus the emission of a low-energy photon, since for any given experimental energy resolution, photons emitted at sufficient low energy will be undetected. Very soft quanta are always radiated by the scattered electron.

The total experimental rate through order α corresponds to

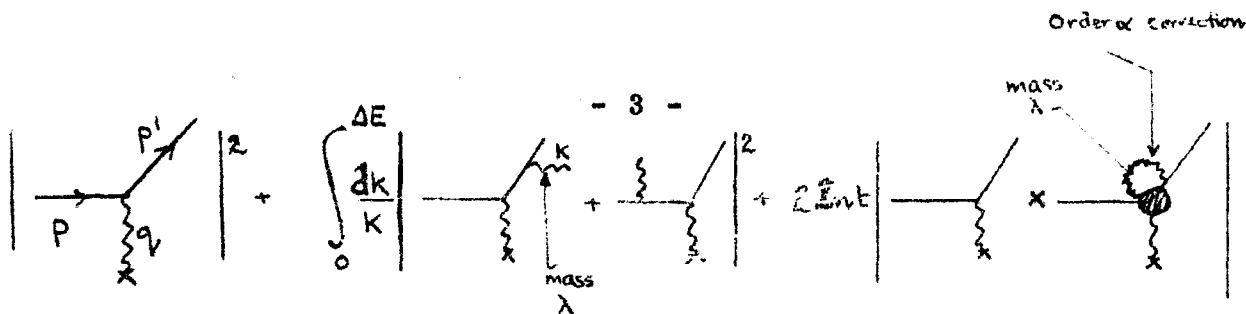

and is finite for $\lambda \rightarrow 0$. (See Yennie, 1963 ; Yennie, Frautshi, and Suura, 1961; and Meister and Yennie, 1963).

The most recent theoretical result for the electron anomalous moment is [Levine and Wright, 1971 - see also Brodsky and Drell] ,

$$a_e^{\text{theor}} = \frac{1}{2} \frac{\alpha}{\pi} - 0.328479 \left(\frac{\alpha}{\pi} \right)^2 + 1.46 \left(\frac{\alpha}{\pi} \right)^3 \pm 0.20$$

Compared to [$\alpha^{-1} = 137.03608(26)$]

$$a_e^{\text{exp}} = \frac{1}{2} \frac{\alpha}{\pi} - 0.328479 \left(\frac{\alpha}{\pi} \right)^2 + 1.68 \left(\frac{\alpha}{\pi} \right)^3 \pm 0.33$$

III. THE HYDROGEN ATOM

The low-lying levels of the hydrogen atomic spectrum are shown in Fig. 3-1. If one ignores

- (1) proton recoil, finite size, and magnetic moment corrections, and
- (2) the fact that in the real world electrons can absorb and radiate light; i. e. , take the limits

$$\frac{m_e}{M_p} \rightarrow 0, \quad \frac{\text{proton size}}{\text{Bohr radius}} \rightarrow 0, \quad \alpha \rightarrow 0 \quad (\text{III. 1})$$

(but leave $Z\alpha$, the binding parameter, finite), then the hydrogen atom can be exactly described in terms of the eigensolutions and eigenvalues of the Dirac equation for an electron in a Coulomb potential given 40 years ago by Darwin and Gordon. [Complete discussions and references are given in Bethe and Salpeter (1957)].

One of the goals of these lectures is to describe the apparatus we have from QED which, in principle, exactly describes the physical atom both in vacuum and in its interactions with external fields. In particular, we shall try to postpone taking the $m_e/M_p \rightarrow 0$ limit for as long as possible. We do this for three reasons:

- (1) Nontrivial proton recoil corrections of order $(Z\alpha)^5 (m_e/M_p)m_e \log Z\alpha$ are required to compare with the experimental level shifts in hydrogen;

The Hydrogen Atom.

Fig. 3-1.

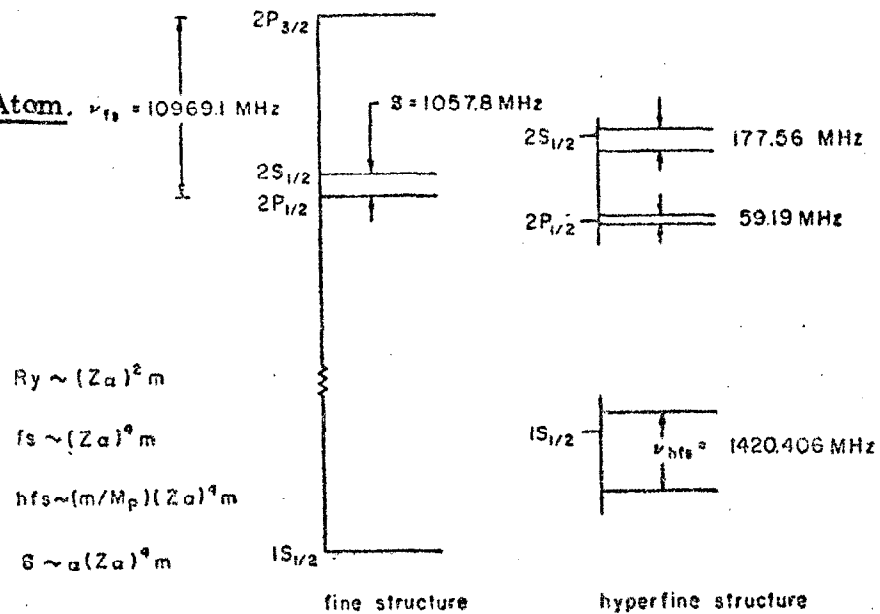

(2) in positronium, no such expansion exists, and
(3) avoiding the infinite mass limit gives a new perspective to understanding the atom.

As we shall see in Lecture 5, such an extended viewpoint is quite essential in understanding the spin interactions of the atom in an external electric field.

III. 1. The Energy Levels of the Atom and an Experiment

Let us now consider the theoretical description of an experiment which measures the total absorption cross section for photon scattering on a hydrogen atom at rest. Using the optical theorem, we can calculate this cross section from the imaginary part of the forward scattering Compton amplitude. The general result of time-dependent perturbation theory for the Compton scattering matrix element is ($\omega = |\vec{k}|$)

$$S_{fi} = -2\pi i \delta(E_i + \omega - E_f - \omega') M_{fi} \quad (\text{III. 2})$$

where \neq

\neq In the complete reduction of the S-matrix, correction terms occur for M_{fi} corresponding to "non-pole" diagrams such as

and also renormalization graphs for the external lines, etc. Such contributions have negligible effect on the experiment of interest here. (See Low, 1952).

$$\begin{aligned}
 M_{fi} &= \sum_j \frac{\langle f, \underline{k}' \hat{\epsilon}' | H_{em} | j \rangle \langle j | H_{em} | i, \underline{k} \hat{\epsilon} \rangle}{E_i + \omega - E_j + i\epsilon} \\
 &+ \sum_j \frac{\langle f, \underline{k}' \hat{\epsilon}' | H_{em} | j, \underline{k}' \hat{\epsilon}' \rangle \langle j, \underline{k}' \hat{\epsilon}' | H_{em} | i, \underline{k} \hat{\epsilon} \rangle}{E_i - \omega' - E_j + i\epsilon} \quad (\text{III. 3})
 \end{aligned}$$

corresponding to the diagrams in Fig. 3-2.

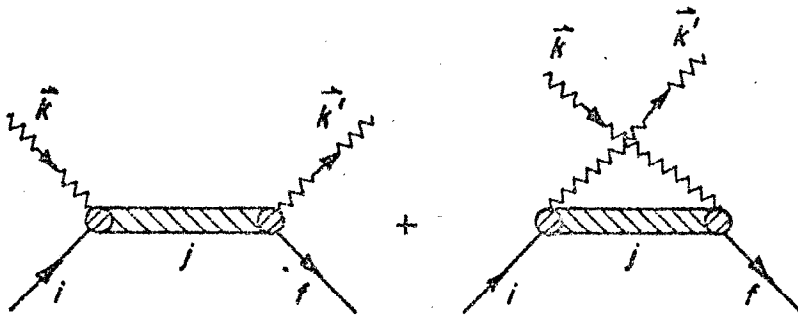

Figure 3-2

A fundamental postulate of QED is that the interaction takes the form

$$H_{em} \equiv \int d^3x \mathcal{H}_I(\underline{x}, 0) = e \int d^3x \underline{A}(\underline{x}, 0) \cdot \underline{j}(\underline{x}, 0) \quad (\text{III. 4})$$

where \underline{A} connects states differing by one photon

$$\langle 0 | \underline{A}(\underline{x}) | \underline{k} \hat{\epsilon} \rangle = \frac{e^{i\underline{k} \cdot \underline{x}}}{\sqrt{2\omega (2\pi)^3}} \hat{\epsilon} \quad (\text{III. 5})$$

The current, $\underline{j}(\underline{x}, 0)$, whose matrix elements will be discussed in detail later, can connect the ground state of the hydrogen atom $|i\rangle$ to all excited and continuum electron-proton states $|j\rangle$ plus states containing extra electron-positron or proton-antiproton pairs. ⁷ For illustration we shall use this "old-fashioned" perturbation theory expression for M_{fi} to calculate Compton scattering on a free electron. Restricting ourselves to lowest order, the intermediate states which can contribute are shown (crossing the dashed line) in Figure 3-3

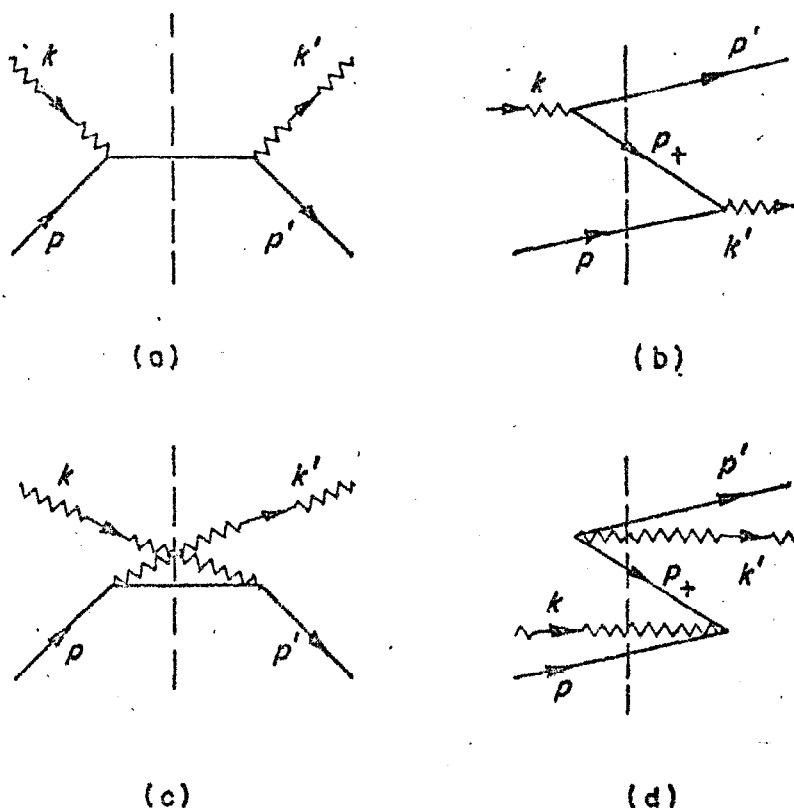

FIGURE 3-3

⁷ Further, since there is no energy constraint, the proton could be excited in the intermediate states. A complete dynamical analysis would require extra "seagull" terms added to M_{fi} corresponding to 2-photon interactions with virtual pions and other bosons.

The matrix element in QED for the current between free electron states is

$$\langle P_2 | \underline{j}(x) | P_1 \rangle = e^{i(P_1 - P_2) \cdot x} u^\dagger(P_2) \underline{\alpha} u(P_1) \quad (\text{III. 6})$$

and we immediately see the general result that 3-momentum is conserved at each H_{em} vertex. For diagram 3-3(a) we obtain

$$M_{fi}^{(a)} = \frac{e^2}{\sqrt{2\omega_2 \omega'}} (2\pi)^3 \delta^3(\underline{k} + \underline{p} - \underline{k}' - \underline{p}') u^\dagger(\underline{p}') \underline{\alpha} \cdot \hat{\underline{E}}' \frac{\sum_{spin} u(\underline{p} + \underline{k}) u^\dagger(\underline{p} + \underline{k}) \underline{\alpha} \cdot \hat{\underline{E}}}{E + \omega - \sqrt{(\underline{k} + \underline{p})^2 + m^2} + i\epsilon} u(\underline{p}) \quad (\text{III. 7})$$

where

$$\sum_{spin} u(\underline{q}) u^\dagger(\underline{q}) = \Lambda_+(q) = \frac{E_q + \underline{\alpha} \cdot \underline{q} + \beta m}{2E_q}, \quad E_q = \sqrt{\underline{q}^2 + m^2} \quad (\text{III. 8})$$

is the positive energy projection operator. \neq

For the "Z" diagram 3-3(d) the matrix of the current between an electron and an $e^- e^+ e^-$ state for the bottom vertex is

$$\langle P' | \underline{j}(x) | P', P_+, P \rangle = e^{i(P' + P_+) \cdot x} v^\dagger(P_+) \underline{\alpha} u(P) \quad (\text{III. 9})$$

where after integration over \underline{x} , the positron momentum is $\underline{p}_+ = -\underline{p} - \underline{k}$. The vertex at the top vertex must differ in sign because of Fermi statistics:

$$\begin{aligned} \langle P | \underline{j}(x) | P', P_+, P \rangle &= - \langle P | \underline{j}(x) | P, P_+, P' \rangle \\ &= - e^{i(P' + P_+) \cdot x} v^\dagger(P_+) \underline{\alpha} u(P') \end{aligned} \quad (\text{III. 10})$$

\neq Our notation differs slightly here from Bjorken and Drell (1964).

Thus we obtain for diagram 3-3(d)

$$M_{fi}^{(a)} = -e^2 \frac{1}{\sqrt{2\omega 2\omega'}} (2\pi)^3 \delta^3(\underline{k} + \underline{p} - \underline{k}' - \underline{p}') \bar{u}(\underline{p}') \alpha \cdot \hat{\underline{\epsilon}}' \sum_{spin} \frac{v(-\underline{p}-\underline{k}) v^\dagger(-\underline{p}-\underline{k}) \alpha \cdot \hat{\underline{\epsilon}}}{-\omega' - E' - \sqrt{(\underline{k} + \underline{p})^2 + m^2} + i\epsilon} u(\underline{p}) \quad (\text{III. 11})$$

where the sum over positron spinors gives a "negative energy" projection operator:

$$\sum_{spin} v(-\underline{q}) v^\dagger(-\underline{q}) = \Lambda_-(\underline{q}) = \frac{E_q - (\alpha \cdot \underline{q} + \beta m)}{2E_q} \quad (\text{III. 12})$$

We now note the following important identity:

$$\frac{\Lambda_+(\underline{q})}{q_0 - \sqrt{q^2 + m^2} + i\epsilon} + \frac{\Lambda_-(\underline{q})}{q_0 + \sqrt{q^2 + m^2} - i\epsilon} = \frac{q_0 + m}{q^2 - m^2 + i\epsilon} \gamma_0 = \frac{1}{q_0 - m + i\epsilon} \gamma_0 \quad (\text{III. 13})$$

for which we identify

$$q_0 = \omega + E = \omega' + E', \quad \underline{q}^2 = (\underline{k} + \underline{p})^2$$

The total of diagrams 3-3(a) and 3-3(d) thus gives

$$M_{fi}^{(a)+(d)} = \frac{e^2}{\sqrt{2\omega 2\omega'}} (2\pi)^3 \delta^3(\underline{k} + \underline{p} - \underline{k}' - \underline{p}') \bar{u}(\underline{p}') \gamma_\mu \hat{\underline{\epsilon}}' \frac{1}{\not{p} + \not{k} - m + i\epsilon} \gamma_\mu \hat{\underline{\epsilon}} u(\underline{p}) \quad (\text{III. 14})$$

which agrees with the Feynman rules for diagram 3-4(a) (see, e. g. Bjorken and Drell, 1964).

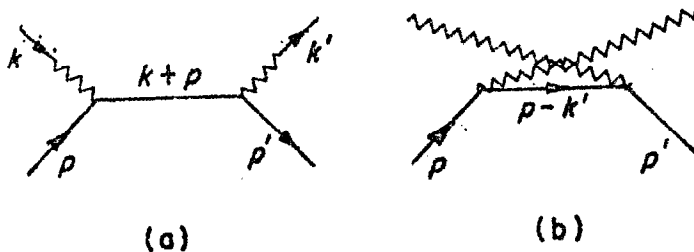

FIGURE 3-4

Similarly diagrams 3-3(b) and (c) sum to the crossed Feynman diagram 3-4(b).

$$M_{fi}^{(b)+(c)} = \frac{e^2}{\sqrt{2\omega 2\omega'}} (2\pi)^3 \delta^3(\mathbf{k} + \mathbf{p} - \mathbf{k}' - \mathbf{p}') \bar{u}(\mathbf{p}') \boldsymbol{\gamma} \cdot \hat{\boldsymbol{\epsilon}} \frac{1}{\not{\mathbf{p}} - \not{\mathbf{k}}' - m + i\epsilon} \boldsymbol{\gamma} \cdot \hat{\boldsymbol{\epsilon}}' u(\mathbf{p}) \quad (\text{III. 15})$$

Energy and momentum are conserved at each vertex of the Feynman diagram.

The identity (3.13) shows that the Feynman propagator $(\not{q} - m + i\epsilon)^{-1}$ contains the electron and $e^- e^- e^+$ contributions automatically. Widening our view, we see that graphs 3-3(a) and (d) have the same vertices. The Feynman propagator automatically contains all time orderings of the interactions along the electron line.

Further discussion and interpretations may be found in Sec. 6 of Bjorken and Drell (1964), Sakurai (1967), and, of course, the original articles of Feynman (1949, 1950). Many of the original papers on QED are reprinted in the volume edited by Schwinger (1958).

We should also note that

$$\frac{\Lambda_-(\mathbf{q})}{q_0 + \sqrt{q^2 + m^2}} = \frac{1}{q_0 - \boldsymbol{\alpha} \cdot \mathbf{q} - \beta m} (E_q - \boldsymbol{\alpha} \cdot \mathbf{q} - \beta m) \frac{1}{2E_q} \quad (\text{III. 16})$$

$$\cong \frac{1}{2E_q} \quad \text{for } \omega, \omega' \ll m$$

Thus diagrams 3-3(a) and (d) give

$$M_{fi} \propto e^2 \bar{u}(\mathbf{p}') \frac{\hat{\boldsymbol{\epsilon}} \cdot \hat{\boldsymbol{\epsilon}}'}{m} u(\mathbf{p}) \quad (\text{III. 17})$$

corresponding to the $A^2/2m$ vector potential term in the Schrodinger equation for nonrelativistic electrons. In addition 3-3(a) and (c) vanish for $\omega = \omega' \rightarrow 0$ ($\mathbf{p} = \mathbf{p}' = 0$); the Thomson limit for Compton scattering on the electron thus arises from the "Z" diagrams.

III. 2. Definition of Energy Levels from Measurement

Let us return to our study of photoabsorption and Compton scattering on the atom. Obviously M_{fi} as it stands in (3.3) is singular when $E_i + \omega = E_j$. Formally, this catastrophe is alleviated by the radiative corrections to the bound electron propagator (see Lecture 6) and leads to a replacement

$$E_j - i\epsilon \longrightarrow E_j - i\Gamma/2 \quad (\text{III. 18})$$

This just corresponds to giving the state $|j\rangle$ a decaying state time dependence,

$$e^{-iHt} = e^{-iE_j t - \frac{1}{2}\Gamma t} \quad (\text{III. 19})$$

For a rigorous treatment of the quantum theory of decaying states and the line width see the text Quantum Mechanics by A. Messiah (North Holland Publishing Company, Amsterdam, 1962), Vol. II, Chap. XXI-13.

Exercise: Prove this starting from the definition of M_{fi} from time-dependent perturbation theory.

$$S_{fi} = \frac{(-i)^2}{2} \int d^4x_1 \int d^4x_2 \langle f, k' | T(\mathcal{H}_I(x_1), \mathcal{H}_I(x_2)) | i, k \rangle \quad (\text{III. 20})$$

where T is the time-ordering operator and

$$\mathcal{H}_I(x) = e^{iH_0 t} \mathcal{H}_I(x, 0) e^{-iH_0 t}, \quad \int \mathcal{H}_I(x, 0) d^3x = H_{em} \quad (\text{III. 21})$$

If the width of state $|j\rangle$ is narrow the first term (the "direct channel") clearly dominates M_{fi} when

$$\omega + E_i \cong E_j \quad (\text{III. 22})$$

Operationally, we may define the energy levels of the atom to be the energy values of $\omega + E_i$ such that the photoabsorption cross section peaks. The apparent shift in energy due to other, nonresonant, terms in the sum (III. 3) is of order $\alpha(Z\alpha)^8 m$ and can be neglected (see Low, 1952). Aside from the fact that the recoil energy is included in E_j (a negligible effect, except perhaps for positronium) the definition (III. 22) matches up well with the usual Breit-Wigner analysis of the atomic-beam experiments.

III. 3. Physical Derivation of the Bethe-Salpeter Equation

It is now of interest to compare M_{fi} with the expression for the Compton matrix element as obtained from the QED Feynman rules, as given, e. g., in Bjorken and Drell (1964). The relevant diagrams are shown in Figure 3-5

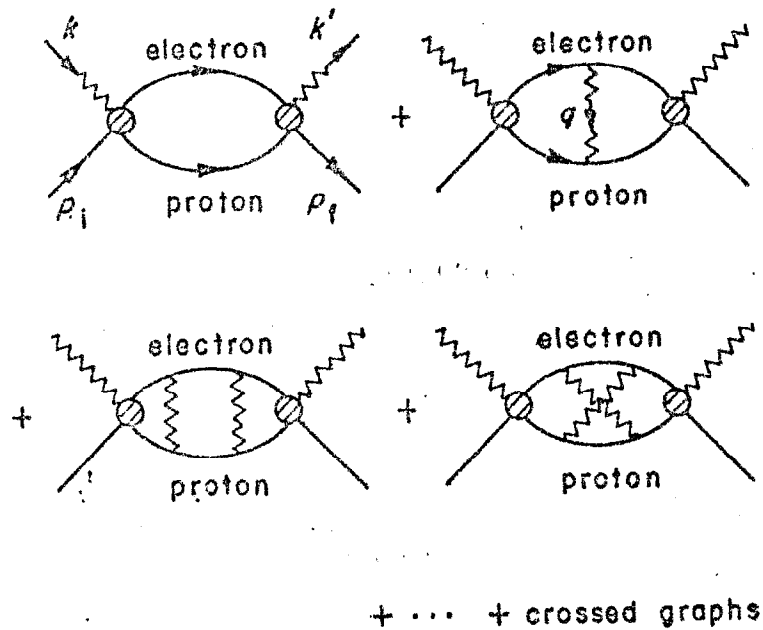

FIGURE 3-5

and the corresponding (direct channel) matrix elements are

$$\bar{\chi}_f(P_f) \Gamma \cdot \hat{\epsilon} \left[\frac{1}{(P_e - m_e)(P_p - m_p)} + \int \frac{d^4q}{(2\pi)^4} \frac{1}{(P_e' - m_e)(P_p' - m_p)} V \frac{1}{(P_e - m_e)(P_p - m_p)} + \dots \right] \Gamma \cdot \hat{\epsilon} \chi_i(P_i) \quad (\text{III. 23})$$

where Γ represents the matrix element of the current between bound and free electron-proton states and $V \propto \gamma_\mu (1/q^2) \gamma^\mu$ represents one photon exchange.

Energy and moment are conserved at each vertex so

$$P = k + P_i = P_e + P_p \quad (\text{III. 24})$$

We can formally sum up all the diagrams contributing to the scattering amplitude if we use the propagator

$$\mathcal{X} = \frac{1}{(P_e - m_e)(P_p - m_p) - G} = \frac{1}{(P_e - m_e)(P_p - m_p)} \cdot [1 + G \mathcal{X}] \quad (\text{III. 25})$$

to represent the electron-proton diagrams where

$$G = \sum_{\text{irreducible}} V^{(i)} \quad (\text{III. 26})$$

The summation is clearly only over irreducible "kernels" $V^{(i)}$, i. e. the effective scattering potentials which cannot be separated into other kernels by crossing a line only through free electron and proton lines. Note that by including just the one-photon-exchange kernel all of the "ladder" graphs are generated for electron-proton scattering.

Exercise: Interpret Eq. (III. 25) in position-space representation where $\langle x_1 x_2 | \mathcal{X} | x_1' x_2' \rangle$ is the two-body Green's function.

If Feynman diagrams are to yield the resonant scattering form (III. 3) for $\omega + E_i = P_0 = E_j$, we must have (up to a factor)

$$\mathcal{K} \gamma_0^a \gamma_0^b = \frac{|j\rangle\langle j|}{P_0 - E_j + i\epsilon} = \frac{|j\rangle\langle j|}{P_0 - \sqrt{P^2 + M_j^2} + i\epsilon} \quad (\text{III. 27})$$

Then, multiplying the recursion relation (III. 25) for \mathcal{K} by $(P_0 - E_j) \rightarrow 0$ we immediately obtain the Bethe-Salpeter equation (Salpeter and Bethe, 1951)

$$(\not{P}_e - m_e)(\not{P}_p - m_p)|j\rangle = G|j\rangle, \quad (P_e + P_p = P) \quad (\text{III. 28})$$

an eigenvalue equation for $M_j = \sqrt{P_0^2 - P^2}$.

In position-space representation we have

$$(i \not{\partial}_e - m_e)(i \not{\partial}_p - m_p)\chi_j(x_e, x_p) = (G\chi_j)(x_e, x_p) \quad (\text{III. 29})$$

where

$$\chi_j(x_a, x_b) = e^{-iP_j \cdot X} \chi_j(x) \quad (\text{III. 30})$$

since $|j\rangle$ is an eigenstate of total 4-momentum: $P_j^2 = E_j^2 - P_j^2 = M_j^2$.

We have used here c. m. and relative coordinates

$$X = \tau_a x_a + \tau_b x_b$$

$$x = x_a - x_b$$

$$\tau_a = m_a / (m_a + m_b), \quad \tau_b = m_b / (m_a + m_b) \quad (\text{III. 31})$$

We shall also require the Bethe-Salpeter equation in momentum space. Introducing total and relative momentum variables,

$$P = P_a + P_b$$

$$p = \tau_b P_a - \tau_a P_b \quad (\text{III. 32})$$

one obtains

$$\begin{aligned} & [\gamma^{(a)} \cdot (\tau_a P + p) - m_a] [\gamma^{(b)} \cdot (\tau_b P - p) - m_b] \psi(p, P) \\ &= \int d^4 p' G(p, p', P) \psi(p', P) \end{aligned} \quad (\text{III. 33})$$

which is an eigenvalue equation for fixed $P^2 = P_0^2 - P^2 = M^2$.

The above derivation of the Bethe-Salpeter equation is admittedly nonrigorous, but it does clearly show the connection of the BS equation with measurement. Rigorous derivations from field theory have been given by Gell-Mann and Low (1951), and Schwinger (1951). Further discussion of the more formal aspects of the equation and references may be found in a book by D. Lurie (1968). Also see Mandelstam (1955).

Exercise: Replace the interaction with the proton in Fig. 3-5 by a Coulomb potential. Use the above method to "derive" the Dirac equation.

III. 4. Kernels for the Hydrogen Atom

Some of the BS kernels which must be included to understand the H-atom spectrum to an accuracy comparable with experiment are shown in Table 3-1.[†] The effects of the various kernels will be discussed in detail in later lectures.

III. 5. Reduction to the Dirac Equation

It is often customary in various applications - especially in hadron physics - to specialize the Bethe-Salpeter equation to ladder approximation i. e., only consider one kernel - usually corresponding to one boson exchange, $G = G(p-p')$. Although the Schrodinger equation is obtained from the one-photon-exchange ladder approximation BS equation for $m_e/M_p \rightarrow 0$, it is not generally appreciated that the Dirac equation is recovered in this static limit only if crossed graph kernels are retained. To see this, consider e-p scattering in fourth order. The relevant Feynman graphs are shown in Fig. 3-6.

[†] Technically, in the calculation of transverse photon exchange and order $-\alpha$ self-energy contributions one must retain Coulomb exchange diagrams to all orders in $Z\alpha$. [See Sec. 6.]

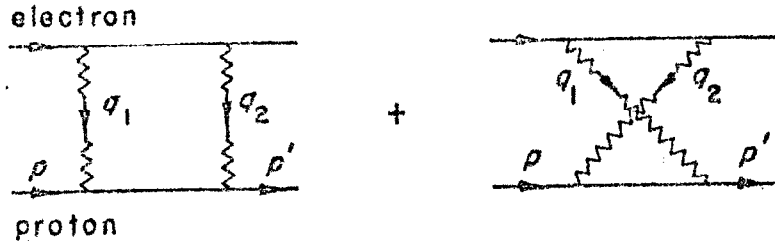

FIGURE 3-6

Table 3.1. Exact calculation of the hydrogen spectrum

Bethe-Salpeter equation

TABLE 3-1. Exact calculation of the hydrogen spectrum

Bethe-Salpeter equation

$$(\not{P}_e - m_e)(\not{P}_p - m_p)\chi = G\chi$$

$$G = G_{1\gamma} + G_{crossed} + G_{vac. pol.}$$

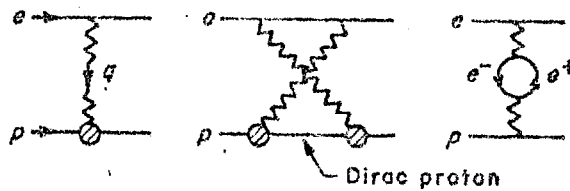

$$+ G_{self-energy} + G_{nuclear polarization} + \dots$$

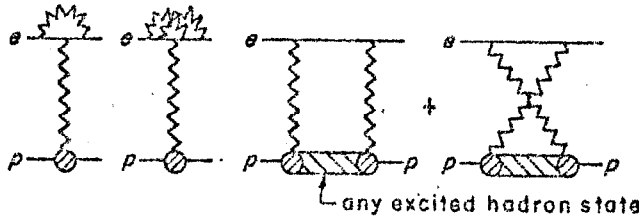

$$G_{1\gamma} = G_{Coulomb} + G_{transverse}$$

$$-\epsilon_H \frac{1}{q^2} \epsilon^H = \epsilon_0 \frac{1}{q^2} \epsilon_0 + \sum_{i=1,2} \epsilon_i \frac{1}{q^2} \epsilon_i$$

- $G_{Coulomb}$ → Schrödinger equation, proton finite size correction
- $+ G_{transverse}$ → reduced mass corrections, HFS splittings
- $+ G_{crossed}^{(all)}$ → Dirac equation, relativistic reduced mass correction
- $+ G_{vac. pol.} + G_{self-energy}$ → Lamb shift, radiative corrections to HFS
- $+ G_{nucl. pol.}$ → correction to HFS

Expansion Parameters: $\alpha, Z\alpha, m/M_p$, (nucleon size)/(Bohr radius)

It is easy to see that only the Coulomb exchange terms ($\mu_1 = 0, \mu_2 = 0$) survive for $M \rightarrow \infty$. Also in this limit, the proton line factor in the matrix element is

$$\begin{aligned} & \lim_{M \rightarrow \infty} \bar{u}(p'_p) \gamma_0 \left[\frac{p_p + q_1 + M}{(p_p + q_1)^2 - M^2 + i\epsilon} + \frac{p_p + q_2 + M}{(p_p + q_2)^2 - M^2 + i\epsilon} \right] \gamma_0 u(p_p) \\ &= \lim_{M \rightarrow \infty} \left[\frac{1}{\omega_1 + q_1^2/2M + i\epsilon} + \frac{1}{-\omega_1 + q_2^2/2M - (q_1 + q_2)^2/2M + i\epsilon} \right] \quad (\text{III. 34}) \\ &= -2\pi i \delta(\omega_1) \end{aligned}$$

where we used $\omega_2 = -\omega_1 + E' - E = -\omega_1 - (q_1 + q_2)^2/2M$.

The $\delta(\omega_1)$ expresses energy conservation for scattering in a static field and reduces the 4-dimensional Feynman integration over d^4q_1 to 3-dimensions - appropriate to the matrix element from the perturbation expansion of the Dirac equation to second order in the Coulomb field. Clearly the cross graph is essential to this result.

The proof for e-p scattering can be readily extended to all orders in perturbation theory. \neq The n diagrams which arise for n-photon exchange can be combined to give a single proton line factor

\neq Our discussion here is similar to a proof given by D. R. Yennie (Private communication).

$$\prod_{j=1}^n \omega_j^+ / \prod_{k=1}^n \omega_k^+$$

where

$$\omega_k^+ = \omega_k + O\left(\frac{q_k^2}{2M}\right) + i\epsilon$$

If we use

$$\omega_n = -\sum_{j=1}^{n-1} \omega_{j'} - \frac{\left(\sum_{l=1}^n q_{l'}\right)^2}{2M}$$

then for $M \rightarrow \infty$ the factor is

$$\frac{\prod_{j=1}^{n-1} \omega_j^+}{\prod_{k=1}^{n-1} \omega_k^+} \cdot \left[\frac{1}{\omega_n^+} + \frac{1}{\sum_{j'}^{n-1} \omega_{j'}^+} \right] = -2\pi i \delta\left(\sum_{j'}^{n-1} \omega_{j'}^+\right) \frac{\prod_{j=1}^{n-2} \omega_j^+}{\prod_{k=1}^{n-2} \omega_k^+} \cdot \left[\frac{1}{\omega_{n-1}^+} + \frac{1}{\sum_{j'}^{n-2} \omega_{j'}^+} \right] \quad (\text{III. 35})$$

$$= \dots = (-2\pi i) \delta(\omega_1 + \omega_2 + \dots + \omega_{n-1}) (-2\pi i) \delta(\omega_1 \dots \omega_{n-2}) \dots (-2\pi i) \delta(\omega_1)$$

which provides the $(n-1)$ δ -functions required to reproduce the Lippman-Schwinger series for an electron scattering in a Coulomb potential.

To explicitly derive the Dirac equation within the Bethe-Salpeter formalism, let us return to the two-body kernel K in the c.m. system for

$$P^0 = P_p^0 + P_e^0 \equiv M_p + E_j$$

If we assume $|E_j - P_e^0| \ll M_p$ then

$$P_p^0 \equiv M_p$$

and we can take

$$\frac{1}{P_p^0 - M_p + i\epsilon} = \frac{\Lambda_+(P_p)}{P_p^0 - \sqrt{P_p^2 + M_p^2} + i\epsilon} \gamma_0 \quad (\text{III. 36})$$

We can then show, using the same techniques as for the scattering problem,

$$\begin{aligned} \left[\mathcal{K} - \frac{1}{(P_e^0 - m_e)(P_p^0 - M_p)} \right] &= \frac{1}{(P_e^0 - m_e)(P_p^0 - M_p)} \chi_c \frac{1}{(P_e^0 - m_e)(P_p^0 - M_p)} \\ &+ \frac{1}{P_e^0 - m_e} \chi_c \left[\mathcal{K} - \frac{1}{(P_e^0 - m_e)(P_p^0 - M_p)} \right], \end{aligned} \quad (\text{III. 37})$$

where $\gamma_0^e \chi_c = \chi_c$ is the Coulomb potential for the electron

[including $\delta(q_0)$]. Identifying

$$i \mathcal{K} \gamma_0^e \gamma_0^p = \frac{|j\rangle \langle j|}{P_0 - E_j + i\epsilon} \quad (\text{III. 38})$$

for $P_0 \approx E_j$, then gives for $P_0 \rightarrow E_j$

$$(P_e^0 - m_e)|j\rangle = \chi_c |j\rangle, \quad (P_e^0 = E_j), \quad (\text{III. 39})$$

which is the required equation.

Again, crossed diagrams are essential to obtain the Dirac result. As a general note, the ladder approximation to the Bethe-Salpeter equation can be expected to fail when terms second order in the potential are required.

IV. THE RELATIVISTIC ATOM

In the last lecture we saw how one is inevitably led to the Bethe-Salpeter equation in order to describe the two-body system in relativistic quantum mechanics. As it stands the Bethe-Salpeter equation is quite unwieldy and certainly requires an approximation scheme; i. e. an approximate, tractable, two-body equation which will give reasonably good results by itself, and a perturbation theory to take into account neglected terms and possible external field interactions. The necessary perturbation theory can be easily developed from the techniques of the last lecture and is briefly discussed below. The required approximate equation has been given by Salpeter (1952) and is reviewed in Section IV. 3. An alternate scheme based on an effective potential for the one-body equation has been proposed by Yennie and Grotch and is discussed in Section VII. 2.

IV. 1 Perturbation Theory in the Bethe-Salpeter Formalism

Perturbation theory for the relativistic atom can be readily developed from the expansion of the two-body propagator near an energy pole. Suppose we wish the perturbation of the energy E_j for a bound state of fermions a and b due to an extra irreducible kernel δG . For

$$P_0 \approx E_j = E_j^0 + \delta E_j$$

$$\frac{i}{(P_a - m_a)(P_b - m_b) - (G^0 + \delta G)} \gamma_0^a \gamma_0^b = \frac{|j\rangle\langle j|}{P_0 - (E_j^0 + \delta E_j) + i\epsilon} \quad (IV. 1)$$

$$\begin{aligned} \frac{i}{(P_a - m_a)(P_b - m_b) - G_0} \delta G \frac{1}{(P_a - m_a)(P_b - m_b) - G_0} \gamma_0^a \gamma_0^b &= \frac{|j\rangle\langle j| \delta E_j}{(P_0 - E_j^0 + i\epsilon)^2} \\ &= -i \frac{|j_0\rangle\langle j_0| \gamma_0^a \gamma_0^b \delta G |j_0\rangle\langle j_0|}{(P_0 - E_j + i\epsilon)^2} \end{aligned} \quad (IV. 2)$$

We write

$$|j\rangle = |j_0\rangle + |\delta j\rangle, \quad (IV. 3a)$$

where \neq

$$\langle j_0 | \delta_j \rangle = 0, \quad \langle j_0 | j_0 \rangle = \langle j | j \rangle + o(\delta G)^2 \quad (\text{IV. 3b})$$

Then

$$\delta E_j = -i \langle j_0 | \gamma_0^a \gamma_0^b \delta G | j_0 \rangle \quad (\text{IV. 4})$$

or in momentum space,

$$\delta E_j = -i \int d^4 p d^4 p' \bar{\Psi}_{j_0}(P, P') \delta G(P, P', P) \Psi_{j_0}(P, P) \quad (\text{IV. 5})$$

The normalization condition consistent with this result can be found by choosing a δG for which we know a priori what δE_j must be. Again we consider

$$\frac{|j\rangle\langle j|}{P_0 - E_j + i\epsilon} = \frac{i}{(P_a - m_a)(P_b - m_b) - G} \gamma_0^a \gamma_0^b \quad (\text{IV. 6})$$

for

$$P_0 \cong E_j, \quad P_a^0 + P_b^0 = P_0$$

Note that P_0 is just a parameter in this relation. Let us change its value to $P_0 + \delta P_0$, where δP_0 is small:

$$\frac{|j\rangle\langle j|}{P_0 + \delta P_0 - E_j + i\epsilon} = \frac{i}{[(P_a - m_a)(P_b - m_b) - G] + \left\{ \partial[(P_a - m_a)(P_b - m_b) - G] / \partial P_0 \right\} \delta P_0} \gamma_0^a \gamma_0^b \quad (\text{IV. 7})$$

Thus

$$\delta G \equiv - \frac{\partial}{\partial P_0} [(P_a - m_a)(P_b - m_b) - G] \delta P_0 \quad (\text{IV. 8})$$

must produce an energy shift $\delta E_j = -\delta P_0$; consequently we must

\neq Actually, the orthonormalization condition takes the form $\langle n | Q | m \rangle = \delta_{nm}$, where Q is proportional to the total charge operator. See equations (IV. 9) and (IV. 15).

have (in momentum space)

$$-i \int d^4 p' d^4 p \bar{\Psi}(P, p') \frac{\partial}{\partial P_0} \left[(\tau_a \not{p}' + \not{p}' - m_a)(\tau_b \not{P} - \not{p} - m_b) \delta^4(P - p') \right. \\ \left. + G(P, p', p) \right] \Psi(P, p) = 1. \quad (IV.9)$$

This is the general normalization condition of the relativistic wave function. Other derivations are given in Lurie (1968) and Smith (1968). In ladder approximation, $\partial G / \partial P_0 = 0$ and

$$-i \int d^4 p \bar{\Psi}(P, p) \left[\frac{m_a}{m_a + m_b} \gamma_0^{(a)} (\not{p}' - m_b) + \frac{m_b}{m_a + m_b} \gamma_0^{(b)} (\not{p}' - m_a) \right] \Psi(P, p) = 1. \quad (IV.10)$$

IV. 2 The electromagnetic Current of the Composite System

We shall also use the technique of the previous section to derive the first-order interaction of the atom with an external field. The obvious application is to the general derivation of the Zeeman effect for the atom in a static magnetic field. A careful analysis of radiative and recoil corrections to the Zeeman effect is of more than historical interest. The analyses of all the fine-structure and Lamb-shift measurements depend on a precise (up to 1 ppm) theoretical extrapolation of experiment results from high (~ 3500 gauss) to zero magnetic field. In view of the serious disagreement of the Lamb-shift measurements and the theoretical predictions, it is especially worthwhile to be critical of the standard treatments of the Zeeman effect (Lamb, 1952; Robiscoe, 1968; Brodsky and Parsons, 1967) which are based on an additive interaction Hamiltonian appropriate to free particles ($x_a^0 = x_b^0 = t$)

$$H_{em} = e_a \gamma_0^{(a)} \gamma_\mu^{(a)} A^\mu(x_a) + e_b \gamma_0^{(b)} \gamma_\mu^{(b)} A^\mu(x_b) \quad (IV.11)$$

+ anomalous moment contributions.

It should be noted that this Hamiltonian involves approximately a many-time formalism where each particle has not only its own x , but also t , by a single-time formalism.

Again we return to a description of the Compton scattering experiment - but this time an external field $A_{ext}^\mu(x)$ is present.

The dominant diagram for $\omega \cong E_m - E_i$, $\omega' \cong E_n - E_f$, is shown in Figure 4.1. For photon energies in these regions,

$$M_{fi} \cong \frac{\langle f, k' | H_I | n \rangle \langle n | H_{ext} | m \rangle \langle m | H_I | i, k \rangle}{(E_i + \omega - E_m + i\epsilon)(E_f + \omega' - E_n - i\epsilon)} \quad (IV. 12)$$

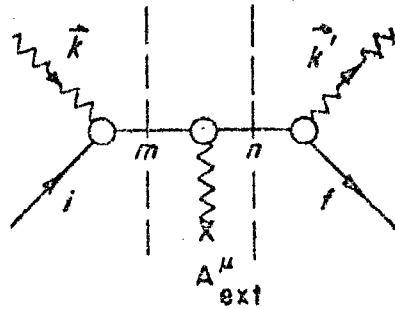
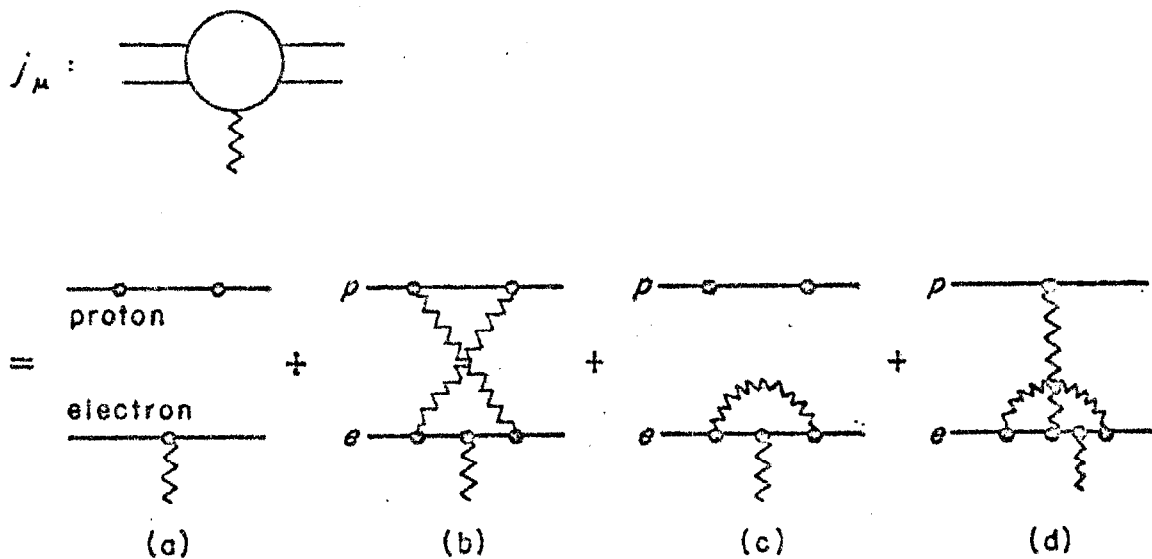

FIGURE 4-1

By matching this up with the Feynman-diagram description we find

$$\langle n | H_{ext} | m \rangle = -i \int d^4 p d^4 p' d^3 p' d^3 p \bar{\psi}_n(p', p) j_\mu(p', p, p', p) \times A_{ext}^\mu(p - p') \psi_m(p, p) \quad (IV. 13)$$

where the two-body current j_μ is calculated from the effective kernel and irreducible diagram expansions are shown in Figure 4-2.



+ ... + proton line insertions

Figure 4-2.

Diagram 4-2(c) gives the anomalous moment $\alpha/2\pi$ coupling to the external field. [Compare with Eq. (II. 2) for the free-electron vertex.] Diagram 4-2(d) and similar graphs containing additional exchanged photons give a binding correction to the anomalous moment interaction. For consistency (and gauge invariance), if one retains a certain set $G^{(i)}$ of kernels in the Bethe-Salpeter equation then one must keep only the corresponding irreducible diagrams for j_μ corresponding to attaching the external photon on all charged lines. The first derivation (from field theory) of these results was given by Mandelstam (1955).

In ladder approximation, only graph 4-2(a) is retained and

$$j_\mu = e_a \gamma_\mu^{(a)} (\not{P}_b - m_b) \delta^4(P_b' - P_b) + e_b \gamma_\mu^{(b)} (\not{P}_a - m_a) \delta^4(P_a' - P_a) \quad (IV. 14)$$

where an inverse fermion propagator must be used to tie the legs of the Feynman graphs together properly. It is easy to check that this current is conserved [again in the ladder approximation]. Thus by the definition of the total charge $Q = \int d^3x j_0(x)$

$$\langle n | Q | n \rangle = (e_a + e_b)$$

$$= -i \int d^4p \bar{\Psi}_n(P, p) [e_a \gamma_0^{(a)} (\not{P}_b - m_b) + e_b \gamma_0^{(b)} (\not{P}_a - m_a)] \Psi_n(P, p) \quad (IV. 15)$$

which is consistent with the normalization condition Eq. (IV. 10) for ladder approximation. We might also note that one obtains the same results in ladder approximation for a static external potential from the equation (Schwinger, 1951)

$$[\not{P}_a - e_a A_{\text{ext}}(x_a) - m_a][\not{P}_b - e_b A_{\text{ext}}(x_b) - m_b] \psi = G \psi \quad (IV. 16)$$

which is valid to all orders in A_{ext} . Other interaction terms in A_{ext} must be explicitly added if G contains kernels beyond one boson exchange.

Before completing the analysis of the Zeeman theory it will be necessary to study an approximate form of the Bethe-Salpeter formalism. After this is done we will be able to understand how the conventional Dirac results emerge and what are the sizes of the correction terms.

IV. 3. The Salpeter Equation

Since the Coulomb interaction is the dominant interaction in the H-atom it is appropriate to focus our attention on instantaneous kernels:

$$G(x_a - x_b) = -ig(x_a - x_b) \delta(x_a^0 - x_b^0) \quad (IV.17)$$

In momentum space the interaction has no q_0 dependence. Introducing total and relative momentum variables

$$P = P_a + P_b, \quad p = \tau_b P_a - \tau_a P_b = (m_b P_a - m_a P_b) / (m_a + m_b) \quad (IV.18)$$

the BS equation becomes

$$\begin{aligned} & [\gamma^a \cdot (\tau_a P + p) - m_a][\gamma^b \cdot (\tau_b P - p) - m_b] \psi(P, p) \\ &= \frac{-1}{2\pi i} \int d^4 p' g(\underline{p} - \underline{p}') \psi(P, p) \end{aligned} \quad (IV.19)$$

where

$$g_c(\underline{p} - \underline{p}') = -\frac{Ze^2}{(2\pi)^3} \frac{1}{(\underline{p} - \underline{p}')^2}, \quad e^2 = 4\pi\alpha, \quad Z = 1. \quad (IV.20)$$

for the Coulomb case.

The Bethe-Salpeter equation in instantaneous ladder approximation can be taken as a simplified first approximation to the complete analysis.

Since the interaction can be instantaneous in only one frame, let us restrict ourselves to the c.m. frame $\underline{P} = 0, \underline{p}_a = \underline{p}_b = \underline{p}$.

Defining free-particle projection operators

$$\begin{aligned} \Lambda_{\pm}^a(\underline{p}_a) &= [E_a(\underline{p}_a) \pm H_a(\underline{p}_a)] / 2E_a(\underline{p}_a) \\ E_a(\underline{p}_a) &= \sqrt{\underline{p}_a^2 + m_a^2} \\ H_a(\underline{p}_a) &= \underline{\alpha} \cdot \underline{p}_a + \beta_a m_a \end{aligned} \quad (IV.21)$$

we obtain four equations for $\psi_{S_a S_b} = \Lambda_{S_a}^a \Lambda_{S_b}^b \psi(S_a, S_b = \pm 1)$

$$[\tau_a P_0 - S_a E_a(\underline{P}_a) + P_0][\tau_b P_0 - S_b E_b(\underline{P}_b) - P_0] \psi_{S_a S_b}(P_a, P_b)$$

$$= \frac{-1}{2\pi i} \Lambda_{S_a}^a \Lambda_{S_b}^b \gamma_0^a \gamma_0^b \int d^4 P' g(P-P') \psi(P', P') \equiv \Gamma_{S_a S_b} \quad (\text{IV. 22})$$

One is then able to integrate over p_0

$$\varphi_{S_a S_b}^{P_0}(\underline{P}) = \int_{-\infty}^{\infty} dP_0 \psi_{S_a S_b}(P_a, P_b)$$

$$= \int_{-\infty}^{\infty} dP_0 \frac{\Gamma_{S_a S_b}}{[\tau_a P_0 - S_a E_a(\underline{P}_a) + P_0 + i\delta S_a][\tau_b P_0 - S_b E_b(\underline{P}_b) - P_0 + i\delta S_b]}$$

$$= -[\delta_{S_a, +1} \delta_{S_b, +1} - \delta_{S_a, -1} \delta_{S_b, -1}] \frac{2\pi i}{P_0 - S_a E_a - S_b E_b} \Gamma_{S_a S_b} \quad (\text{IV. 23})$$

(The Feynman contour prescription corresponds to negative imaginary parts of m_a and m_b). Note that $\varphi_{+-} = \varphi_{-+} = 0$

Adding these equations together gives the Salpeter equation (1952) ($\tilde{g} = \gamma_0^a \gamma_0^b g$)

$$[P_0 - H_a(\underline{P}) - H_b(-\underline{P})] \varphi(\underline{P}) = [\Lambda_+^a \Lambda_+^b - \Lambda_-^a \Lambda_-^b] \int d^3 P' \tilde{g}(P-P') \varphi(P') \quad (\text{IV. 24})$$

which is an eigenvalue equation for P_0 . The elimination of the p_0 dependence is a consequence of the instantaneous kernel. Also we can define an auxiliary 3-dimensional wave function $\eta(\underline{p})$ such that

$$[P_0 - H_a - H_b] \eta(\underline{P}) = \int d^3 P' \tilde{g}(P-P') \varphi(P') \quad (\text{IV. 25})$$

Then ψ is completely determined in terms of η :

$$\Psi_{S_a S_b}(P_a P_b) = \left(\frac{-1}{2\pi i} \right) \frac{P_0 - S_a E_a - S_b E_b}{[L_a P_0 - S_a E_a + P_0 + i\delta S_b][L_b P_0 - S_b E_b - P_0 + i\delta S_a]} \eta_{S_a S_b}(P) \quad (IV. 26)$$

and the normalization condition (IV. 10) becomes

$$\int d^3p \varphi^\dagger(p) [\Lambda_+^a \Lambda_+^b - \Lambda_-^a \Lambda_-^b] \varphi(p) = 1. \quad (IV. 27)$$

Thus, if the interaction is instantaneous the dynamics can be completely specified by the $x_0 = 0$ wave function $\varphi(p)$. In general, however, the relative time coordinate x_0 or p_0 is essential to take into account the relative time-orderings of the interactions.

A peculiarity of the Salpeter equation is the presence of the Λ_\pm operators in the potential term. The consequence of this is that in a time-ordered perturbation theory development of Eq. (IV. 24), the double "Z" states (i. e. $e^+ e^-$, pp) occur, but single "Z" intermediate states do not. This is an expected result for ladder approximations with an instantaneous kernel (see Fig. 4-3).

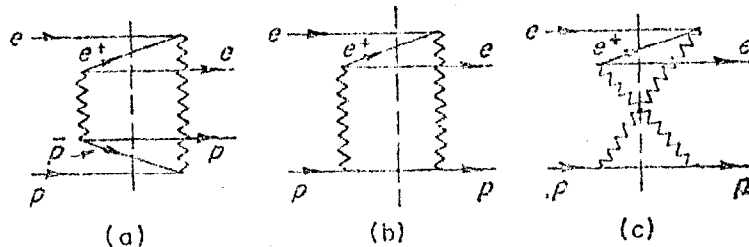

FIGURE 4-3

The absence of diagrams IV-3(b) and (c) in the Salpeter perturbation theory shows why the Salpeter equation cannot give Dirac results for $M_p \rightarrow \infty$. In fact, one obtains in that limit

$$[E_a - H_a(p)] \varphi = \Lambda_+^a \tilde{g} \varphi, \quad (IV. 28)$$

which is the Dirac equation with $(e^+ e^-) e^-$ contributions to intermediate states eliminated.

The Salpeter equation (IV. 24) bears a strong resemblance to the Breit equation for two particles (Breit, 1929).

$$[E_0 - H_a(p) - H_b(p)] \varphi_B(p) = \int d^3p' \tilde{g}(p-p') \varphi_B(p') \quad (IV. 29)$$

The Breit equation is considerably easier to handle than the Salpeter equation and unlike the latter, reduces to the Dirac equation for

$m_e/M_p \rightarrow \infty$. Despite the fact that the Breit equation is not

fully relativistic, it is found to be useful to compare results of the Salpeter equation calculations term by term with the corresponding Breit result - especially in isolating contributions which just correspond to reduced mass corrections (Salpeter, 1952). When terms of relative order m_e/M_p are considered in a given calculation, the Breit and Salpeter equations may only yield results accurate to first order in the binding \neq . The Salpeter equation, however, can be made as precise as required by the inclusion of crossed graphs through the perturbation theory given in Section IV.1.

If the additional perturbation is also an instantaneous kernel, the energy shift from Eqs. (IV.5) and (IV.26) is just

$$\Delta E = \int d^3p d^3p' \left[\psi_{++}^\dagger(\underline{p}') \delta \tilde{g}(\underline{p}, \underline{p}') \psi_{++}(\underline{p}) + \psi_{--}^\dagger(\underline{p}') \delta \tilde{g}(\underline{p}, \underline{p}') \psi_{--}(\underline{p}) \right] \quad (IV.30)$$

We will apply this result to the calculation of radiative level shifts in Section VI. In the nonrelativistic limit with $m_e/M_p \rightarrow 0$, $\psi_{--} \rightarrow 0$,

$\psi_{++} \rightarrow \psi_{NR}$, and the energy shift reduces to the usual expression

in nonrelativistic perturbation theory.

\neq The Breit equation leads to errors of relative order $Z\alpha m_e/M_p$ in the fine and hyperfine structure formulas.

IV. 4. THE ATOMIC ZEEMAN EFFECT [≠]

We now return to the discussion of the interaction of the atom with a static magnetic field. Using Eq. (IV. 26) for the explicit p_0 dependence of the wave function, one can perform the contour integrals over p_0 and p_0' indicated in Eq. (IV. 13) for $\langle n | H_{\text{ext}} | m \rangle$. The position-space result for ladder approximation is

$$\langle n | H_{\text{ext}} | m \rangle = \int d^3x_a d^3x_b \varphi_n^\dagger(x_a, x_b) H_{\text{ext}}^S \varphi_m(x_a, x_b) \quad (\text{IV. 31})$$

where $E_a = \sqrt{p_a^2 + m_a^2}$

$$\begin{aligned} H_{\text{ext}}^S = & \Lambda_+^{(a)} e_a \gamma_0^{(a)} \gamma^{(a)} \cdot A(x_a) \Lambda_+^{(a)} - \Lambda_-^{(a)} e_a \gamma_0^{(a)} \gamma^{(a)} \cdot A(x_a) \Lambda_-^{(a)} \\ & + \left[\Lambda_+^{(a)} e_a \gamma_0^{(a)} \gamma^{(a)} \cdot A(x_a) \Lambda_-^{(a)} \frac{1}{p_0^m - p_0^w + E_a + E_a'} \tilde{g}(x) \right. \\ & \left. - \Lambda_-^{(a)} e_a \gamma_0^{(a)} \gamma^{(a)} \cdot A(x_a) \Lambda_+^{(a)} \frac{1}{p_0^n - p_0^w + E_a + E_a'} \tilde{g}(x) \right. \\ & \left. + (n \leftrightarrow m, \text{H.c.}) \right] + (a \rightarrow b). \end{aligned} \quad (\text{IV. 32})$$

[≠] This discussion follows Brodsky and Primack (1969)

The formidable terms proportional to the binding potential are necessary to compensate for the Λ_-^a Λ_+^b deficiencies in the Salpeter wave function and insure agreement with the Dirac theory for $M \rightarrow \infty$.[‡] The most important result, however, is that simple perturbation theory for the Breit equation with

$$H_{\text{ext}}^B = e_a \gamma_0^{(a)} \mathcal{A}(x_a) + e_b \gamma_0^{(b)} \mathcal{A}(x_b) \quad (\text{IV. 33})$$

will yield the same energy shift as obtained from Eq. (IV. 31) in the Salpeter formalism, to first order in the binding.

In fact, since the Breit formalism is exact for $M_p \rightarrow \infty$, the energy shift due to an external field A_{ext}^μ as calculated from the Breit equation is correct except for terms of order

$$[e \gamma \cdot A \tilde{g}^2 / m_a m_b]$$

The possible error for the Zeeman effect of the hydrogen atom is thus of relative order $(Z\alpha)^4 m_e / M_p$. In addition, however, there are other contributions to the Zeeman effect from neglected kernels for the current (see Figure 4-2):

[‡] But only to first order in g . Higher orders require the addition of crossed graph kernels to the Salpeter theory.

(i) The self-energy and vacuum polarization kernels yield anomalous moment contributions (which can be added on to the Breit interaction) plus errors from binding corrections of relative order $\alpha(Z\alpha)^2$. (See Brodsky and Parsons, 1967; Lieb, 1955). These corrections correspond to the change in the Lamb shift itself due to the magnetic field.

(ii) The cross-graph kernels give a contribution of relative order $(Z\alpha)^4$ (which is included in the Breit equation) plus errors of order $(Z\alpha)^4 m_e/M_p$. Similar estimates hold for non-Coulomb contributions of the photon interaction.

V. THE ATOM IN AN EXTERNAL FIELD †

In this lecture we will construct a model relativistic wave function for the hydrogen atom which exhibits the full 16-component spinor structure of the 2-fermion system. For our purposes we will only require a wave function which is consistently accurate to lowest order in the Coulomb potential. Accordingly we will use the Breit equation to treat the electron-proton interaction.

V. I. AN APPROXIMATE WAVE FUNCTION

We specialize first to the c.m. system where the Breit equation takes the following form:

$$[\underline{\alpha}^a \cdot \underline{p} + \beta^a m_a - \underline{\alpha}^b \cdot \underline{p} + \beta^b m_b + U - \mathcal{M}] \varphi_m = 0 \quad (\text{V. 1})$$

Since U is taken as the Coulomb potential † it contains no Dirac matrices.

† The material in this lecture is based on work done with J. R. Primack (Brodsky and Primack, 1969).

† In general, the transverse Breit potential should also be included. We also ignore commutators of ω_a with ω_b .

We write

$$\phi_{JM} = \begin{pmatrix} 1 \\ \omega_a \end{pmatrix} \otimes \begin{pmatrix} 1 \\ \omega_b \end{pmatrix} \phi_{JM} \chi_{SM} \quad (V. 2)$$

where ω_a and ω_b are 2x2 matrices and functions of \underline{p} and $\underline{\sigma}_{a,b}$, ϕ_{JM} is a one-component function of the relative coordinate and

χ_{SM_1} ($S = 1, 0$) is a constant spinor and eigenstate of total spin $S_z = \frac{1}{2} (\underline{\sigma}_a + \underline{\sigma}_b)_z$ and S^2 .

The Breit equation is satisfied if we take

$$\omega_a = \frac{1}{2m_a + k_a} \underline{\sigma}_a \cdot \underline{P}, \quad \omega_b = \frac{1}{2m_b + k_b} \underline{\sigma}_b \cdot (-\underline{P}). \quad (V. 3)$$

and if ϕ_{JM} satisfies a "Pauli" relativistic two-body equation

$$\left[\underline{\sigma}_a \cdot \underline{P} \frac{1}{2m_a + k_a} \underline{\sigma}_a \cdot \underline{P} + \underline{\sigma}_b \cdot \underline{P} \frac{1}{2m_b + k_b} \underline{\sigma}_b \cdot \underline{P} + U + W \right] \phi_{JM} \chi_{SM} = 0 \quad (V. 4)$$

Here W is the binding energy,

$$W = m_a + m_b - M > 0 \quad (V. 5)$$

and

$$k_a = \frac{m_a}{m_a + m_b} (U + W), \quad k_b = \frac{m_b}{m_a + m_b} (U + W) \quad (V. 6)$$

and kinetic energy operators: if k_a could be commuted with $\underline{\sigma}_a \cdot \underline{p}$, then

$$(k_a \rightarrow \underline{p}^2 / 2m_a + O(\underline{p}^4 / m^3)).$$

Note that if spin-orbit and other relativistic terms are dropped, Eq. (V. 4) reduces to the two-body Schrodinger equation in the c.m. frame,

$$\left(\frac{\underline{p}^2}{2m_r} + U + W \right) \phi_{JM} = 0 \quad (V. 7)$$

where $m_r = m_a m_b / (m_a + m_b)$. It should be noted that due to the neglect of the transverse potential, Eq. (V. 4) will be incorrect for obtaining reduced-mass corrections to the fine structure.

The c.m. solution for total spin S and projection $S_z = M$ takes the following form in position space [‡]

$$\begin{aligned} \Phi_m(x_a, x_b, X^0)_{SM} &= \int \frac{d^3p}{(2\pi)^{3/2}} \left(\frac{P_a^0 + m_a}{2P_a^0} \right)^{1/2} \left(\frac{P_b^0 + m_b}{2P_b^0} \right)^{1/2} \\ &\times \begin{pmatrix} 1 \\ \frac{\underline{\sigma}_a \cdot \underline{p}}{2m_a + k_a} \end{pmatrix} \otimes \begin{pmatrix} 1 \\ \frac{-\underline{\sigma}_b \cdot \underline{p}}{2m_b + k_b} \end{pmatrix} \phi_m(p) \chi_{SM} \exp(i\underline{p} \cdot \underline{x} - imX_0) \end{aligned} \quad (V. 8)$$

where

$$x = x_a - x_b, \quad X = \tau_a x_a + \tau_b x_b, \quad P_{a,b}^0 = \sqrt{p^2 + m_{a,b}^2} \quad (V. 9)$$

The normalization of ψ_m is compatible with (IV. 27) if

$$\int d^3p [|\phi_m(p)|^2] = 1 \quad (V. 10)$$

V. 2 THE WAVE FUNCTION OF THE ATOM IN MOTION

Equation (V. 4) provides an excellent starting point for determining the wave function required for the Salpeter theory; corrections to the wave function can be readily handled in perturbation theory.

In calculating the matrix element of the interaction with an external field, the initial and final states will in general have different

[‡] The ordering $(2m_a + k_a)^{-1} (\underline{\sigma}_a \cdot \underline{p})$ is understood here.

total momenta. It will consequently be necessary to know how to transform the c. m. wave function to an arbitrary reference frame and then form wave packets corresponding to superpositions of states with different total momenta.

It should be emphasized that we shall always consider the bound state of the atom to be in a definite state of total spin $\underline{S} = \underline{S}_a + \underline{S}_b$ as defined in its c. m. As is well known, spin does not commute with Lorentz boosts to a moving frame; it must always be defined with respect to a specific Lorentz frame.

The transformation of the Bethe-Salpeter wave function from the c. m. system to a state of total momentum \underline{P} is given by

$$\chi_{E, \underline{P}}(x'_a, x'_b)_{SM} = S_a(\Lambda) S_b(\Lambda) \chi_m(x_a, x_b)_{SM} \quad (V. 11)$$

where

$$S_a(\Lambda) = \sqrt{\frac{E+m}{2m}} \left(1 + \frac{\underline{\alpha}_a \cdot \underline{P}}{m+E} \right) \quad (V. 12)$$

and

$$x'_a = \Lambda x_a, \quad x'_b = \Lambda x_b, \quad (E, \underline{P}) = \Lambda(m, \underline{0}) \quad (V. 13)$$

Thus to obtain the moving wave function $\chi_{E, \underline{P}}(y_a, y_b)_{SM}$

(corresponding to total spin S , and projection $S_z = M$ in its c. m. system) one evaluates the c. m. functions at $\Lambda^{-1} y_a, \Lambda^{-1} y_b$ and applies the spin transformations $S_{a,b}(\Lambda)$.

This can be compared with the transformation for a free electron wave function from rest to momentum \underline{P} .

$$\begin{aligned} S_a(\Lambda) u(0) e^{-imt} &= \sqrt{\frac{E+m}{2m}} \left(1 + \frac{\underline{\alpha} \cdot \underline{P}}{m+E} \right) \begin{pmatrix} \chi \\ 0 \end{pmatrix} e^{-imt} \\ &= u(\underline{P}) e^{-imt} = u(\underline{P}) e^{i\underline{P} \cdot \underline{x}' - iEt'} \end{aligned} \quad (V. 14)$$

The effect of the transformation on the spinor structure of the two-fermion wave function is rather unexpected:

$$\begin{pmatrix} 1 \\ \frac{\underline{S} \cdot \underline{P}}{2m_a + K_a} \end{pmatrix} \rightarrow \begin{pmatrix} 1 + \frac{\underline{S}_a \cdot \underline{P}}{m + E} \cdot \frac{\underline{S}_a \cdot \underline{P}}{2m_a + K_a} \\ \underline{S}_a \cdot \left(\frac{\underline{P}}{m + E} + \frac{\underline{P}}{2m_a + K_a} \right) \end{pmatrix} \quad (\text{V.15})$$

The small (lower) component is just $\sim \underline{S}_a \cdot \underline{P}_a / (2m_a + K_a)$ where \underline{P}_a is the momentum of fermion α in the moving atom. However, the large component has an extra term for $P \neq 0$ which, as we shall see, leads to corrections to the spin-dependent interaction with an external electric field. In addition, the moving state is not an eigenstate of $\underline{S} = \underline{S}_a + \underline{S}_b$

From a physical point of view, what appears as a spin triplet ($S = 1$) state of the two spin $\frac{1}{2}$ fermions in the c.m. frame appears partially as a spin singlet in the moving frame (McGee, 1967).

We can now construct a wave packet for the atom from a super-position of total momentum eigenstates: \neq

$$\varphi(\underline{x}_a, \underline{x}_b, X_0) = \int \frac{d^3P}{(2\pi)^{3/2}} \sqrt{\frac{m}{E}} \Phi(\underline{P}) \varphi_{E, \underline{P}}(\underline{x}_a, \underline{x}_b, X_0) \quad (\text{V.16a})$$

\neq We have ignored here the x_0 dependence of the boosted state. This is an approximation: the wave function can only be chosen at equal time in one Lorentz frame, which we choose as the c.m., where the potential is also defined as instantaneous.

where

$$\varphi_{E, \underline{P}} = \frac{E + m}{2m} \int \frac{d^3 p}{(2\pi)^{3/2}} \left(\frac{P_a^0 + m_a}{2P_a^0} \cdot \frac{P_b^0 + m_b}{2P_b^0} \right)^{1/2} \\ \times \begin{pmatrix} 1 + \frac{\underline{S}_a \cdot \underline{P}}{m + E} & \frac{\underline{S}_a \cdot \underline{P}}{2m_a + k_a} \\ \underline{S}_a \cdot \left(\frac{\underline{P}}{m + E} + \frac{\underline{P}}{2m_a + k_a} \right) \end{pmatrix} \otimes \begin{pmatrix} 1 - \frac{\underline{S}_b \cdot \underline{P}}{m + E} & \frac{\underline{S}_b \cdot \underline{P}}{2m_b + k_b} \\ \underline{S}_b \cdot \left(\frac{\underline{P}}{m + E} - \frac{\underline{P}}{2m_b + k_b} \right) \end{pmatrix} \\ \times \phi_m(\underline{P}) \chi_{SM} \exp[i\underline{p} \cdot \underline{\tilde{x}} + i\underline{P} \cdot \underline{x}] \exp[-iEX_0]. \quad (V.16b)$$

This satisfies the Salpeter normalization condition Eq. (IV. 27) if

$$\int |\Phi(\underline{P})|^2 d^3 P = 1, \quad \int d^3 P |\phi_m(\underline{P})|^2 = 1. \quad (V.17)$$

We have defined $\underline{\tilde{x}}_{\perp} = \underline{x}_{\perp}$, $\underline{\tilde{x}}_{\parallel} = \gamma \underline{x}_{\parallel}$ in (V.16); this corresponds to a Lorentz contraction of the wave packet.

V. 3. THE NONRELATIVISTIC REDUCTION OF THE EXTERNAL FIELD INTERACTION

Let us again consider the atom in an external, static field $A(x)$. We have shown in Lecture IV that the Breit Hamiltonian, extended to include the anomalous moment interactions, is an excellent approximation to the exact Bethe-Salpeter results. We can now use the explicit spinor structure in the relativistic wave function Eq. (V.16) to reduce the 4x4 component form of the interaction to a 2x2 Pauli matrix form. The result as obtained by Brodsky and Primack (1969) and also H. Osborn (1969) is \neq

\neq Here e_a , m_a , μ_a , and $\frac{1}{2}\sigma_a$, are the charge, mass, total magnetic moment and spin of fermion a and $M_T = m_a + m_b$. Note that $\underline{S} = \frac{1}{2}(\underline{\sigma}_a + \underline{\sigma}_b)$ is the total spin in the c.m. frame. The wave function $\phi(\underline{x}_a, \underline{x}_b)$ to be used for evaluated matrix elements of H_{NR}^{em} in general include the Lorentz contraction $x' = \Lambda x$, but in usual applications, this is only important for bound states with $l \geq 1$. Binding correction factors of order $(1 + W/m)$ are neglected here as well as cross terms in the binding potential U and the external field such as $\underline{\sigma} \cdot \nabla U \times \underline{A}$.

$$\begin{aligned}
 H_{NR}^{em} = \sum_{S=a,b} & \left[-\frac{\underline{P}_S \cdot \underline{e}_S \underline{A}_S}{m_S} + \frac{e_S^2 \underline{A}_S^2}{2m_S} + e_S \underline{A}_S^0 - \underline{\mu}_S \underline{\sigma}_S \cdot \underline{H}_S \right. \\
 & \left. - \left(2\mu_S - \frac{e_S}{2m_S} \right) \underline{\sigma}_S \cdot \underline{E}_S \times \frac{(\underline{P}_S - e_S \underline{A}_S)}{2m_S} \right. \\
 & \left. + \frac{1}{4M_T} \left(\frac{\underline{\sigma}_a}{m_a} - \frac{\underline{\sigma}_b}{m_b} \right) \left[e_b \underline{E}_b \times (\underline{P}_a - e_a \underline{A}_a) - e_a \underline{E}_a \times (\underline{P}_b - e_b \underline{A}_b) \right] \right. \\
 & \left. + O\left(\frac{1}{m^3}\right) \right] \quad (V.18)
 \end{aligned}$$

This may be derived from a large component reduction method (accounting for pair states - "Z" diagrams in second-order perturbation theory via \underline{A}^2 terms, etc.) or by a Foldy-Wouthuysen method (taking into account the fact that the F-W transformation does not reduce the wave function to $\begin{pmatrix} 1 \\ 0 \end{pmatrix} \otimes \begin{pmatrix} 1 \\ 0 \end{pmatrix}$ form). H_{NR}^{em} may now be treated in standard perturbation theory using $2 \otimes 2$ Pauli wave functions

$\phi_{M \chi MS}$

The terms proportional to $(M_T m_a)^{-1}$ or $(M_T m_b)^{-1}$ in H_{NR}^{em} are corrections to simple FW additivity (which until 1968 had been assumed correct to order m^{-2} , almost universally in the literature of atomic and nuclear physics. The essential point is that matrix elements of the external potential interaction require knowledge of the bound-state wave function at different total momenta. This brings in the extra terms in the large components of the boosted wave function and in turn leads to the a and b mixed terms in H_{NR}^{em} . For a uniform electric field, the "spin-orbit" terms combine to

$$\begin{aligned}
 & \left[\left(\frac{e_T}{2M_T} - 2\mu_a \right) \frac{\underline{\sigma}_a}{2M_T} + (a \rightarrow b) \right] \cdot \underline{E} \times \underline{P} \\
 & + \left[\left(\frac{e_a}{2m_a} + \frac{e_T}{2m_T} - 2\mu_a \right) \frac{\underline{\sigma}_a}{2m_a} - (a \rightarrow b) \right] \cdot \underline{E} \times \underline{P} \quad (V.19)
 \end{aligned}$$

The first term may be recognised as being exactly the right Thomas term for the atom - taken as a static system with charge e , mass $\mathcal{M} = M_T$, magnetic moment $\mu = \mu_a + \mu_b$, and spin S (as defined in the c.m. From general arguments similar to those of Thomas, the interaction of such a particle with the external field must have terms (Brodsky and Primack, 1969, Sec. 7B),

$$H_{\text{ext}}^{\text{em}} = - \frac{e\hbar}{\mathcal{M}} \underline{P} \cdot \underline{A} - \frac{\mu}{S} \underline{S} \cdot \underline{B} - \left(\frac{\mu}{S} - \frac{e}{2\mathcal{M}} \right) \underline{S} \cdot \underline{E} \times \frac{\underline{P}}{\mathcal{M}} + \dots \quad (\text{V. 20})$$

which agrees with (V. 19). In addition one can derive from general principles such as special relativity and current conservation (Low, 1954; Gell-Mann and Goldberger, 1954; Abarbanel and Goldberger, 1968) the low-energy theorem for forward Compton scattering on any stable target with spin S , charge e , mass \mathcal{M} , and magnetic moment μ . The general spin result of Lapidus and Kuang-Chao (1960) is

$$M_{fi} = \frac{1}{2\omega} (2\pi)^3 \delta^3(\underline{P}_f - \underline{P}_i) \times \left[\frac{e^2}{\mathcal{M}} \delta_{fi} \hat{\underline{E}} \cdot \hat{\underline{E}} + i\omega \left(\frac{\mu}{S} - \frac{e}{\mathcal{M}} \right)^2 S_{fi} \cdot \hat{\underline{E}}' \times \hat{\underline{E}} + O(\omega^2) \right] \quad (\text{V. 21})$$

Thus the first two terms in ω in the forward amplitude are determined solely by the static properties. One can explicitly show (Brodsky and Primack, 1969) that by including the corrections to FW additivity in $H_{\text{NR}}^{\text{em}}$ one indeed obtains the correct spin-dependent term for forward Compton scattering on the atom.

Exercise: Consider a nonrelativistic atom of two spin-zero particles:

$$H = \sum_{S=a,b} \frac{(\underline{P}_S - e_S \underline{A}_S)^2}{2m} + V$$

Derive the forward amplitude M_{fi} to lowest order in ω .

Instead of using H_{NR}^{ext} and Pauli wave functions in bound-state calculations of Compton scattering, etc. it is often easier to use the relativistic operators and wave functions directly. The need for the correction terms to the upper components is then explicit. In such calculations one is eventually required to separate relative and total coordinates. This can be accomplished for \underline{a} by use of such identities as

$$\begin{aligned} & \langle j | \underline{\alpha}_a \cdot \hat{\underline{E}} e^{i\mathbf{k} \cdot \underline{r}_a} | i \rangle \\ &= i \langle j | [H_0, \underline{r}_a \cdot \hat{\underline{E}}] e^{i\mathbf{k} \cdot \underline{r}_a} | i \rangle \\ &= i (E_j - E_i) \langle j | \underline{r}_a \cdot \hat{\underline{E}} e^{i\mathbf{k} \cdot \underline{r}_a} | i \rangle - i\omega \langle j | \underline{r}_a \cdot \hat{\underline{E}} \underline{\alpha} \cdot \hat{\underline{k}} e^{i\mathbf{k} \cdot \underline{r}_a} | i \rangle \quad (V. 22) \end{aligned}$$

and then separating \underline{r}_a . (For further details, see Brodsky and Primack, 1969, Sec. 6).

The low-energy theorem, together with dispersion relations has led to construction of a sum rule analogous to the Thomas, Reiche, Kuhn sum rule in atomic physics. One writes the forward Compton amplitude in the general form

$$f(\omega) = f_1(\omega^2) \hat{\underline{E}}' \cdot \hat{\underline{E}} + \frac{i\omega}{S} f_2(\omega^2) \underline{S} \cdot \hat{\underline{E}}' \cdot \hat{\underline{E}} \quad (V. 23)$$

and assumes $f_2(\omega^2)$ is an analytic and even function of ω with a cut along the real axis $\omega > \omega_{th}$, where by the optical theorem

$$\text{Im } f_2(\omega^2) = \frac{\sigma_A(\omega) - \sigma_P(\omega)}{8\pi} \quad (V. 24)$$

Here $\sigma_{A,P}(\omega)$ is the total photoabsorption cross section of circularly polarized light on a polarized target. The subscript P(A) refers to the configuration where the photon helicity and target spin are parallel (anti-parallel). If $f_2(\omega^2) \rightarrow 0$ on the circle at ∞ , then by Cauchy's theorem

$$f_2(\omega^2) = \frac{1}{\pi} \int_{\omega_{th}}^{\infty} \frac{\text{Im } f_2(\omega'^2) d\omega'^2}{\omega'^2 - \omega^2} \quad (V. 25)$$

Applied at $\omega^2 = 0$, this yields the DHG sum rule (Drell and Hearn, 1966; S. B. Gerasimov, 1965; Lapidus and Kuang-Chao, 1961; Hosoda and Yamamoto, 1966)

$$\int_{\omega_{th}}^{\infty} \frac{\sigma_p(\omega) - \sigma_n(\omega)}{\omega} \cdot d\omega = -4\pi^2 f_2(0) = \frac{4\pi^2}{S} \left(\mu - \frac{eS}{\mathfrak{M}} \right)^2 \quad (V. 26)$$

Again, the integration over final states can be explicitly computed and verified for the atomic Hamiltonian using the correct wave function and interaction (Brodsky and Primack, 1969).

The DHG sum rule was originally developed from dispersion relations in elementary-particle physics. It is an excellent example of the value of close ties joining the intellectual communities of high- and low-energy physics. In this example, the high-energy physics has supplied atomic physics with an important result for the electromagnetic interaction of a bound system with an external field.

V. 4. APPLICATION TO THE ZEEMAN THEORY

Since the Breit description is adequate for the interaction of the hydrogen atom with an external field, we can calculate the Zeeman effect due to a constant magnetic field \underline{H} from the total Hamiltonian

$$\begin{aligned} \mathcal{H} = & e \underline{\alpha}_e \cdot \underline{A}_e - (2a_e) \frac{e}{2m_e} \underline{S}_e \cdot \underline{H} \\ & + |e| \underline{\alpha}_p \cdot \underline{A}_p - (2a_p) \frac{|e|}{2m_p} \underline{S}_p \cdot \underline{H} + \mathcal{H}_0 \end{aligned} \quad (V. 27)$$

where

$$\underline{A}_e = \frac{1}{2} \underline{H} \times \underline{r}_e, \quad \underline{A}_p = \frac{1}{2} \underline{H} \times \underline{r}_p, \quad e = -|e|. \quad (V. 28)$$

and \mathcal{H}_0 is the Hamiltonian of the atom with no external field applied. The spectrum of \mathcal{H}_0 in lowest order is the (n, j) spectrum of the reduced-mass Sommerfeld formula. The degeneracy with respect

to l is removed by QED corrections, etc. (see Lecture VI) and the degeneracy with respect to total angular momentum f (where $\underline{F} = \underline{L} + \underline{S}_e + \underline{S}_p$) is removed by the hyperfine interaction.[‡]

The spectrum of \mathcal{H}_0 can be specified by the state label $|n, F, j, l, m_F\rangle$. The radial dependence of the eigenfunctions is described accurately except at very small distances $r < m_e^{-1}$ by the Dirac equation with reduced coordinates (Salpeter, 1952; Grotch and Yennie, 1969).

If one performs the radial interaction for the hydrogen $n = 2$ states, then (Lamb and Retherford, 1952; Brodsky and Parsons, 1967)

$$\mathcal{H} = \mathcal{H}_0 + \mu_0 |\mathbf{H}| \left[A_S^e S_z^e + A_S^p S_z^p + \frac{1}{2} L_z A_L + \frac{1}{2} A_L L_z \right] + O(e^2 A_e^2 / m_e), \quad (\text{V. 29})$$

where

$$A_S^e = \begin{cases} g_e (1 + \frac{2}{3} W/m_e) & \text{for } l=0 \\ g_e (1 + \frac{4}{5} W/m_e) & \text{for } l=1 \end{cases} \quad (\text{V. 30})$$

$$A_L = g_L \left(1 + \frac{W}{m_e} - \underline{S}_e \cdot \underline{L} \frac{2}{5} W/m_e \right)$$

and

$$A_S^p = -2 (1 + a_p) m_e / M_p \quad (\text{V. 30b})$$

is the Landé factor for the proton $\cong 5.58 m_e / M_p$. Here $g_L = (1 - m_e / M_p)$ takes into account the nucleon motion about the atomic center of mass, and W

[‡] Also, if $l \neq 0$ the tensor part of the hyperfine interaction is not diagonal in j where $\underline{J} = \underline{L} + \underline{S}_e$.

is the binding energy of the $n = 2$ state:

$$W = -\frac{1}{8} (Z\alpha)^2 m_e (1 - m_e/M_p)$$

The binding corrections to A_S and A_L can be obtained from the Dirac wave functions. Further corrections to A_S of order $(Z\alpha)^2 m_e/M_p$ and higher are discussed by H. Grotch (to be published) and by R. A. Hegstrom (to be published).

The quadratic Zeeman term $\langle \frac{1}{2} e^2 A_e^2 / m_e \rangle$ is approximately 0.01 MHz for $H = 1500$ G. However all $n = 2$ levels are affected similarly and the maximum separation of any two levels is 0.001 MHz at this field which can be ignored, as well as the negligible $\Delta l = 2$ state mixing it induces. One can also show that all $\Delta n \neq 0$ perturbations can be ignored.

One can then proceed to evaluate the energy values of the total Hamiltonian as a function of field strength. A matrix representation (up to 5×5 dimensions for deuterium) of \mathcal{H} in the $n = 2$ space can be obtained, and the eigenvalues can be computed by perturbation theory (Lamb and Retherford, 1952; R. Robiscoe, 1968) or by a simple numerical diagonalization via computer (Brodsky and Parsons, 1967). Taking into account the accuracy of the experimentally determined parameters, and an order of magnitude estimate of neglected theoretical contributions, the expected precision of the Zeeman theory results (see Fig. 5-1) should be better than 1ppm for the present fine-structure measurements.

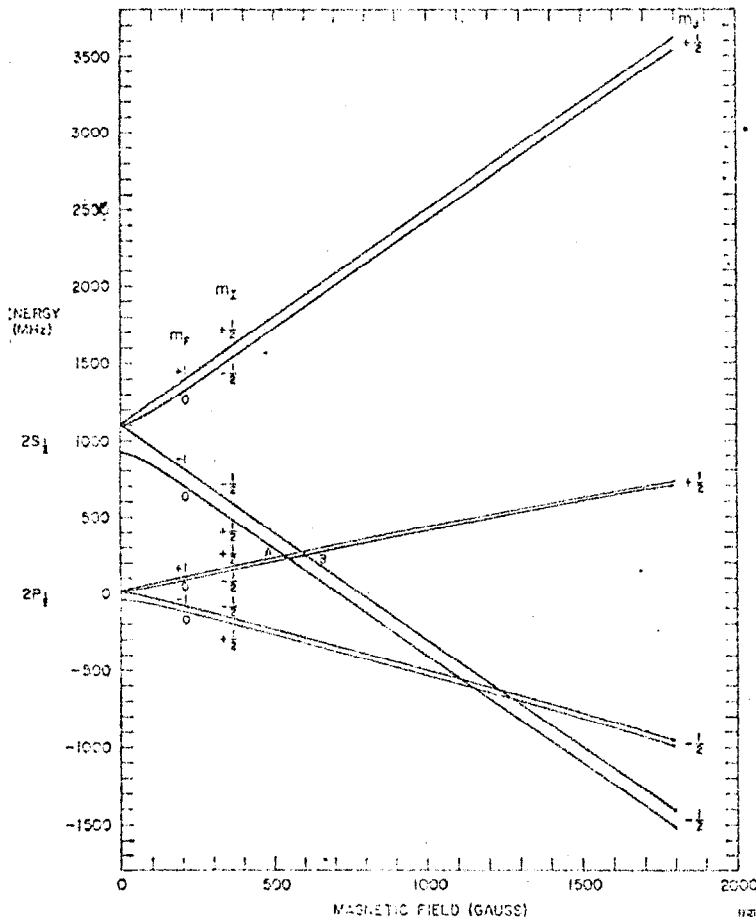

FIG. 5-1. Zeeman spectrum for $n = 2$ levels of hydrogen.

VI. THE LAMB SHIFT

Professor Kleppner has discussed in his lectures (Kleppner, 1969) the experimental history of the measurements of the $2S_{1/2} - 2P_{1/2}$ separation in hydrogen. It would be impossible to overestimate the importance of the measurements by Lamb and his co-workers [‡] on the development of theoretical physics of the last two decades. It is also rather paradoxical that the Lamb shifts in H and D remain the only low-energy tests of QED which are seriously in disagreement with experiment; the latest measurements seem to reaffirm a $\sim 0.3 \pm 0.1$ MHz discrepancy with theory. Accordingly, the theoretical calculations certainly deserve a thorough review. In this lecture we can only outline the course of the calculations and point out the areas not well travelled. The next section is devoted to a qualitative discussion of the effects involved in the level-shift formulae. The self-energy effect, unavoidable due to coupling of the electron with the electromagnetic field, not only contributes to the electron self-energy and anomalous moment but also yields an effective charge distribution. The lowest order result is summarized in the order α expression (II. 2) for the electron form factors. Qualitatively, the photon emission and absorption causes the position of the charge to oscillate. Welton (1948) has given a semi quantitative calculation of the level shift in such a picture. [‡]

[‡]

It might be noted that our language to describe the effects of QED is based on perturbation theory and in turn the smallness of α . The total Hamiltonian consists of 3 parts,

$$\mathcal{H}_{\text{tot}} = \mathcal{H}_0 + \mathcal{H}_{\text{em}} + \mathcal{H}_{\text{int}},$$

where \mathcal{H}_0 describes the atom, \mathcal{H}_{em} describes the quantized electromagnetic field and \mathcal{H}_{int} the coupling between them.

The terms electron and photon refer to eigenstates of \mathcal{H}_0 and \mathcal{H}_{em} . The eventual goal of theory is to understand the

eigenstates of \mathcal{H}_{tot} .

Roughly, the electron charge is spread over a distance $1/m_e$ a fraction α of the time.

To see what a finite charge distribution does to the energy levels of the atom, we calculate the proton size correction. The change in the Coulomb potential

$$\Delta V(r) = \int_{r_N > r} d^3 r_N \rho(r_N) \left(-\frac{Z\alpha}{r_N} + \frac{Z\alpha}{r} \right) \quad (\text{VI. 1})$$

due to the nucleus having a charge distribution $Z | e | \rho(r_N)$ of finite extent, contributes an energy shift $[r_N \ll a_0 = (mZ\alpha)^{-1}]$

$$\begin{aligned} \langle \Delta V \rangle &= \int d^3 r_N \int_{r < r_N} d^3 r |\phi_n(r)|^2 \rho(r_N) \left(-\frac{Z\alpha}{r_N} + \frac{Z\alpha}{r} \right) \\ &\cong |\phi_n(0)|^2 Z\alpha \left(\frac{2\pi}{3} \right) \int d^3 r_N r_N^2 \rho(r_N) \end{aligned} \quad (\text{VI. 2})$$

$$= \frac{2 (Z\alpha)^4 m^3 \int_0^{R_N} R_N^2 \rho(r_N) dr_N}{3 n^3}$$

The shift only affects S-states. For $R_N = 0.8 \times 10^{-13}$ cm, the contribution to the $n = 2$ Lamb shift is 0.127 MHz. It will also be helpful to be familiar with the calculation in momentum space. The presence of the form factor $F_{ch}^D(q^2)$ [the 3-dimensional Fourier transform of $\rho(r_N)$] changes the electron-proton potential: $(q_0 \rightarrow 0)$

$$-\frac{Z\alpha}{q^2} \rightarrow -\frac{Z\alpha}{q^2} F(q^2) = -\frac{Z\alpha}{q^2} \left[1 - \frac{1}{6} R_N^2 q^2 + O(q^4) \right] \quad (\text{VI. 3})$$

The second term corresponds to the position-space perturbation

$$\frac{4\pi \int^3 (r) R_n^2 Z\alpha}{6}$$

and yields the same energy shift. The use of Dirac instead of Schrodinger wave functions does not change the result.

On the other hand we can calculate the form factors of the free electron. Referring back to Eq. (II. 2), we have the one-photon correction to the vertex:

$$-\frac{\partial F_1}{\partial q^2} = \frac{\langle r^2 \rangle}{6} = \frac{\alpha}{3\pi} \frac{1}{m^2} \left(\log \frac{m}{\lambda} - \frac{3}{8} \right) \quad (\text{VI. 4})$$

For the bound electron the integration over intermediate photon momenta is limited to wavelengths less than the Bohr radius:

$$k > k_{\min} \cong Z\alpha m \gg \lambda$$

Thus we have

$$\langle \Delta V \rangle = \frac{2(Z\alpha)^4 m}{3n^3} \left[\frac{\alpha}{3\pi} \log \frac{1}{Z\alpha} \right] \delta_{e0}. \quad (\text{VI. 5})$$

In fact, taking the constant $C \cong 1/7$ gives the observed 2S shift ~ 1050 MHz.

Obviously the above calculation is only meant to be qualitative. The situation will be rectified in the next sections where we discuss the actual calculation using the Erickson-Yennie (1965) method.

VI. 1. THE LEVEL-SHIFT FORMULA

As we outlined in Lectures III - V, the energy levels of the hydrogen atom can be obtained to arbitrary precision by including sufficient irreducible kernels. (See Table 3-1). The order - α electron self-energy contributions, which we restrict ourselves to in this lecture, correspond to Fig. VI. 1.

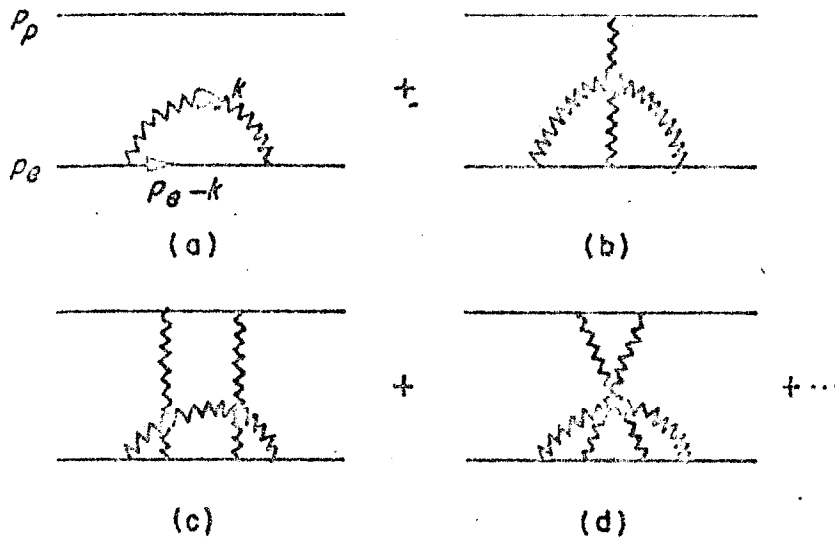

FIGURE 6-1

Figure 6-1(a) corresponds to

$$\Delta G = -ie^2 \int \frac{d^4k}{(2\pi)^4} \gamma_\mu \frac{1}{\not{P}_e - \not{k} - m_e} \gamma^\mu \frac{1}{k^2 + i\epsilon} \quad (VI. 6)$$

If we proceed to the $m_e/M_p \rightarrow 0$ limit, the proton line can be replaced by a Coulomb potential in a Dirac equation description. The total energy shift of state n corresponding to all the order - α electron self-energy diagrams in Fig. 6-1 may then be summed to

$$\Delta E_{S.E.} = \frac{e^2}{(2\pi)^4} \int \frac{d^4k/i}{k^2 + i\epsilon} \langle \bar{n} | \gamma_\mu \frac{1}{\not{P} - \not{k} - m_e + i\epsilon} \gamma^\mu | n \rangle \quad (VI. 7)$$

where

$$\not{\Pi}^\mu = \not{P}_e^\mu - e A^\mu(\underline{x}_e) \quad (VI. 8)$$

and the state $|n\rangle$ satisfies the Dirac equation

$$(\not{H} - m_e) |n\rangle = 0 \quad (\text{VI. 9})$$

In position space $\not{H}^n = (E_n - e A^0(x), -i\nabla - e \underline{A}(x))$.

Additional terms in the self-energy of first order in m_e/M_p could be retained here corresponding to reduced-mass corrections in the Dirac equation and the lowest order hyperfine potential in A^μ .

As is so often the case the Coulomb potential is involved, any expansion in powers of the binding potential must be handled with great care. In particular the final answer will not be analytic in $Z\alpha$, as already in evidence by the $\log Z\alpha$ dependence of our estimate (VI. 5). Thus let us examine some of the features of (VI. 7) without attempting any rash approximations.

In position space the bracket in (VI. 7) takes the form

$$\int d^3x d^3x' \bar{\Psi}_n(x) \delta_\mu(x) \frac{1}{\not{H} - \not{k} - m_e + i\epsilon} |x'\rangle \delta^\mu \Psi_n(x') \\ = \int d^3x d^3x' \bar{\Psi}_n(x) e^{ik \cdot x} \delta_\mu(x) \frac{1}{\not{H} - \gamma_0 k_0 - m_e + i\epsilon} |x'\rangle \delta^\mu e^{-ik \cdot x'} \Psi_n(x') \quad (\text{VI. 10})$$

The sum over positive and negative (bound and continuous state) projection operators can be introduced for the propagator as in Eq. (III. 13). The k_0 contour integration can then be performed to yield

$$\Delta E_n = \frac{e^2}{(2\pi)^3} \int \frac{d^3k}{2\omega} \sum_{\lambda=1}^2 \sum_{n'} \frac{\langle n | \hat{E}_{\lambda \cdot \underline{\alpha}} e^{ik \cdot x} | n' \rangle \langle n' | \hat{E}_{\underline{\lambda} \cdot \underline{\alpha}} e^{-ik \cdot x} | n \rangle}{E_n - E_{n'} - \omega + i\epsilon} \quad (\text{VI. 11})$$

+ [Self-coulomb contribution],

which is exactly the expression one would write in old-fashioned perturbation theory for the self-energy correction to the bound state shown in Fig. 6-2. Note that $|n'\rangle$ includes 3 fermion states which enter with opposite sign. Further details concerning the reduction to (VI. 11) may be found in Yennie (1963) and Erickson (1962).

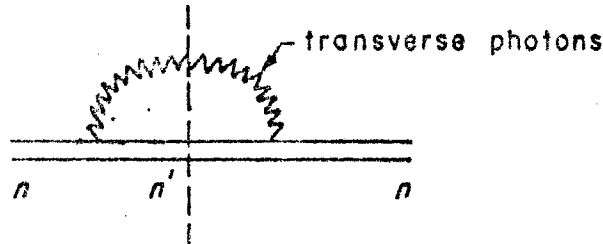

FIGURE 6-2

Note that in general ΔE_n is not real. In fact,

$$\Gamma_n = -\text{Im}(\Delta E_n) = \frac{e^2}{(2\pi)^3} \pi \int \frac{d^3k}{2\omega} \delta(\omega + E_{n'} - E_n) \sum_{\lambda} \sum_{n'} | \langle n | \hat{\epsilon}_{\lambda} \cdot \alpha e^{i\mathbf{k} \cdot \mathbf{r}} | n' \rangle |^2 \quad (\text{VI. 12})$$

is exactly the rate for the state $|n\rangle$ to decay through one photon emission. Thus we finally have justification for use of $E_n - i\Gamma_n$ in the scattering matrix element (III. 3). Note that for a given separation of levels Γ is a constant. The change in Γ for say the $2P_{1/2}$ state in a level crossing experiment due to sweeping the magnetic field across the line is obviously negligible.

Let us now return to the covariant expression (VI 7) for the self-energy level shift. It is easy to show that ΔE_n is invariant under gauge transformations for the external potential A^μ . Thus ΔE_n must be a function of $F^{\mu\nu} = \partial^\mu A^\nu - \partial^\nu A^\mu$ rather than the potential directly. If $F^{\mu\nu}$ is zero, ΔE_n does not vanish; the energy shift is, however, identified as a contribution to the electron mass. [‡] Since this common shift cancels in measurements of transition energies we will understand ΔE_n is at least linear in $F^{\mu\nu}$ and must take the form

[‡] This is of course the mass renormalization first recognised by Bethe (1947). In perturbation theory this contribution, as is well known, is logarithmically divergent.

$$\Delta E_n = \alpha \langle \bar{n} | \dots F_{\mu\nu} \dots Q^{\mu\nu} \dots | n \rangle \quad (\text{VI. 13})$$

where, because of the transformation properties of ΔE_n , $Q^{\mu\nu}$ must be an antisymmetric tensor. The tensors available are

$$(1) \sigma_{\mu\nu} = [\gamma_\mu, \gamma_\nu] / 2i \quad \text{which yields the}$$

magnetic-moment structure

$$M \equiv e \sigma_{\mu\nu} F^{\mu\nu} / 2 = e \underline{\underline{E}} \cdot \underline{\underline{H}} - ie \underline{\underline{\alpha}} \cdot \underline{\underline{E}} \quad (\text{VI. 14})$$

$$(2) \pi^\mu \gamma^\nu - \gamma^\nu \pi^\mu \quad \text{which gives the structure}$$

$$\pi_\mu \dots [\pi^\mu, \cancel{H}]$$

$$(3) F^{\mu\nu} \quad \text{corresponding to}$$

$$F^{\mu\nu} F_{\mu\nu} = \underline{\underline{E}}^2 - \underline{\underline{H}}^2$$

The \dots represent interspersed scalar functions which can involve \cancel{H} , Π^2 , and M or scalar combinations such as $\pi_\mu \dots \pi^\mu$.

A systematic reduction of ΔE_n to calculable term of the type

(1), (2), (3) has been given by Erickson and Yennie (1965). [See also Yennie (1963) : Brodsky and Erickson (1966)]. The procedure is gauge-invariant and avoids "false" expansions where actual logarithmic dependences exist. In brief, the calculation of ΔE_n for the case of the free electron ($F^{\mu\nu} = 0$) is used as a guide for the calculation for the bound electron ($F^{\mu\nu} \neq 0$). The calculations would in fact be identical were it not for the fact that the components of Π do not commute with each other. Remainder terms which are at least linear in

$$[\pi_\mu, \pi_\nu] = -ie F^{\mu\nu} \quad (\text{VI. 15})$$

are thus obtained.

The dominant contribution to the level shift is found to be: [‡]

$$\Delta E_n = -\frac{2\alpha}{3\pi m^2} \langle \bar{n} | \underline{p} \left[\log \frac{m^2}{H} + \frac{11}{24} \right] [\underline{p}, e \underline{A}] | n \rangle$$

$$+ \frac{\alpha}{2\pi} \left(-\frac{e}{2m} \right) \langle \bar{n} | \frac{1}{2} \sigma_{\mu\nu} F^{\mu\nu} | n \rangle \quad (\text{VI. 16})$$

where

$$H \equiv (m - \underline{p})(m + \underline{p}) = m^2 - \underline{p}^2 \cong 2m \left[\underline{p}^2/2m + V - E_{NR} \right]$$

$$= 2m \left[H_{NR} - E_{NR} \right] \quad (\text{VI. 17})$$

This result exactly corresponds to the expected contributions of the $\underline{q}^2 \ll m_e^2$ form factors of the bound electron. The $\sigma_{\mu\nu} F^{\mu\nu}$ term matches with the $\sigma_{\mu\nu} q^\nu A^\mu(\underline{q}) F_2(0)$ anomalous moment contribution, and the $\underline{p} \circ \circ \circ [\underline{p}, \underline{A}]$ structure is the bound electron generalization of the $F_1(0) \underline{q}^2 \not{A}(\underline{q})$ contribution of the charge radius. The $\log(m^2/H) \cong \log(Z\alpha)^{-2}$ dependence shows that the bound electron γ^μ form factor depends in an essential way on the binding. For zero binding, the result is, as expected infrared divergent.

As a first estimate of the contribution (VI. 16) let us take $e \underline{A} = \gamma_0 V$ and approximate the Dirac state $| n \rangle$ by Schrödinger wave

[‡] We have not included here interspersed "form factors"

$\sim (1 + \underline{p}^2/m^2)^{-1}$ which occur in ΔE_n . These serve to suppress the matrix element integration for $| \underline{p} | = m_e$, $r \sim m_e^{-1}$.

functions. For the $\log(m^2/H)$ term we insert a complete set of states (Bethe 1947):

$$\begin{aligned} \text{Re } \Delta E_n^{\log} &= \frac{-2\alpha}{3\pi m^2} \sum_{n'} (\varphi_n, P \varphi_{n'}) \log \frac{m}{2|E_n - E_{n'}|} (E_{n'} - E_n) (\varphi_n, P \varphi_n) \\ &= \frac{-\alpha}{3\pi m^2} (\varphi_n [P, [P, V]] \varphi_n) \log \frac{m}{2|E_n - E_{n'}|_{av}} \quad (\text{VI. 18}) \\ &= \frac{4\alpha (Z\alpha)^4}{3\pi n^3} \cdot m \log \frac{m}{2|E_n - E_{n'}|_{av}} \cdot \delta_{l0} \end{aligned}$$

Exercise: Derive this result directly from the nonrelativistic dipole approximation to Eq. (VI. 11).

The net result of the lowest order contributions is (Bethe, Brown, Stehn, 1950)

$$\text{Re } \Delta E_n = \frac{4}{3\pi} \cdot \frac{\alpha (Z\alpha)^4 m r}{n^3} \left\{ \begin{array}{l} \log \frac{1}{(Z\alpha)^2} + \log \frac{(Z\alpha)^2 m r}{2|E_n - E_{n'}|_{av}} + \frac{11}{24} + \frac{3}{8} - \frac{1}{5}, \quad (\text{s-states}) \\ \log \frac{(Z\alpha)^2 m r}{2|E_n - E_{n'}|_{av}} + \frac{3}{8} \cdot \frac{C_{lj}}{2l+1}, \quad (\text{non-s-states}). \end{array} \right. \quad (\text{VI. 19})$$

where

$$m_r = mM / (m + M) = 1 - m/M$$

$$C_{\ell j} = \begin{cases} \frac{1}{\ell + 1} & , j = \ell + \frac{1}{2} \\ -\frac{1}{\ell} & , j = \ell - \frac{1}{2} \end{cases} \quad (\text{VI. 20})$$

The 3/8 terms here correspond to the $\sigma_{\mu\nu} F^{\mu\nu}$ terms in the second line of (VI. 16). The $-1/5$ is the lowest order vacuum polarization contribution to the energy shift and will be discussed below. The value of $|\epsilon_{n'} - \epsilon_n|_{av} \sim 16.64 \text{ Ry}$ can be obtained very accurately by numerical methods:

For the $n = 2$ states (Harriman, 1956; Schwartz and Tiemann, 1959)

$$\frac{\log(Z\alpha)^2 m_e}{2|\epsilon_{n'} - \epsilon_n|_{av}} = \begin{cases} -2.811769883 (28) & (2S) \\ +0.030016697 (12) & (2P) \end{cases} \quad (\text{VI. 21})$$

Analytical methods for evaluating the Lamb shift in the nonrelativistic atom have also been developed recently (see, e. g., Fronsda1, 1969).

The contribution from Eq. (VI. 19) to the $2S_{1/2} - 2P_{1/2}$ separation in H is 1051 MHz, including -27 MHz from the vacuum polarization term. Higher order corrections for the Lamb shift will be discussed in the next section.

VI. 2. HIGHER ORDER CORRECTIONS

Higher order contributions to the $2S_{1/2} - 2P_{1/2}$ separation contained in (VI. 7) beyond Eq. (VI. 16) arise from corrections from the Dirac equation, corrections from neglected propagators, and terms which are explicitly quadratic or higher in $F_{\mu\nu}$. In fact, only the second term in the $F_{\mu\nu}$ series is required to compare with present experimental accuracy. Nevertheless, great care must be made in making the field strength expansion of the level shift formula. One must avoid expanding

powers of $F_{\mu\nu}$ from propagators which, because of binding corrections, cut off infrared divergence. Similarly, one must avoid expanding too many powers of the potential such that a singular structure like the matrix element of r^{-4} is required. [‡] The effective contribution of such a matrix element is $(Z\alpha)^3 m_e^{-4}$ rather than the nonrelativistic expectation value $a_0^{-4} = (Z\alpha)^4 m_e^{-4}$. These expansions are false expansions in that the residue terms will be of the same order of magnitude in $Z\alpha$ as the terms which are kept. In the calculation of Erickson and Yennie (1965) such pitfalls are avoided by (a) proceeding in a gauge-invariant manner up to the point of actually evaluating numerical contributions and (b) a simple "rule of order" which quickly identifies the order of magnitude (powers of $Z\alpha$) of a given term. Although somewhat involved, their procedures are really quite elegant and probably have application in other areas of atomic physics where a precise expansion of the Dirac Coulomb propagator is required.

Using these procedures, Erickson and Yennie were able to systematically verify previous evaluations of the level-shift formula through orders $\alpha(Z\alpha)^5$, $\alpha(Z\alpha)^6 \log^2(Z\alpha)$, and $\alpha(Z\alpha)^6 \log(Z\alpha)$ and to reliably estimate the contribution of the $\alpha(Z\alpha)^6 m$ [no $\log(Z\alpha)$] contributions. The $\log(Z\alpha)$ factors either arise from the infrared cutoff or from expectation values of operators such as $r^{-3} (1 - e^{-mr})$.

[‡] The matrix element is not divergent, however; the integration region $r < m_e$ is always suppressed by form-factor cutoffs.

If we write

$$\Delta E_n = \frac{4\alpha m c}{3\pi n^3} \left\{ [C_{41} \log(Z\alpha)^{-2} + C_{40}] (Z\alpha)^4 + C_5 (Z\alpha)^5 + [C_{62} \log^2(Z\alpha)^{-2} + C_{61} \log(Z\alpha)^{-2} + C_{60}] (Z\alpha)^6 \right\} \quad (\text{VI. 22a})$$

then c_{41} and c_{40} can be read off of (VI. 19), and

$$c_5 = 3\pi \left(1 + \frac{11}{28} - \frac{1}{2} \log 2 + \frac{5}{192} \right) \quad [\text{Karplus, Klein, and Schwinger (1952) and Bäranger, Bethe, and Feynman (1953) },$$

$$c_{62} = -3/4 \quad [\text{Fried and Yennie (1960) }],$$

$$c_{61} = \begin{cases} 4 \log 2 + 63/40 & 2S_{1/2} \\ 103/240 & 2P_{1/2} \\ 29/240 & 2P_{3/2} \end{cases} \quad [\text{Layzer (1960) }], \quad (\text{VI. 22b})$$

and

$$c_{60} = - \left(\frac{4}{3} \pi^2 + 4 + 4 \log^2 2 \right) \delta_{l0} + b_n,$$

$$|b_n| < 5 \text{ (estimated)} \quad [\text{Erickson and Yennie (1965) }].$$

The estimated term in c_{60} contributes less than ± 0.04 in the $2S_{1/2} - 2P_{1/2}$ separation. The inequality is meant to be a limit of error.

For a review of the fourth order contributions to the Lamb shift see T. Appliquist and S. J. Brodsky, Phys. Rev. 2A, 2293 (1970) and Brodsky and Drell, Ann. Rev. Nucl. Science (1970).

VI. 3. THE VACUUM POLARIZATION CONTRIBUTION

The modification of the Coulomb potential due to virtual electron-positron pairs (Fig. 6-3)

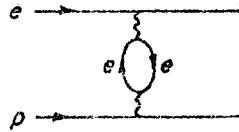

FIGURE 6-3

was understood well before the advent of quantum electrodynamics (Serber, 1935; Uehling, 1935), and actually provided the first motivation for the Lamb-shift measurements.

The change in the photon propagator due to charged pairs is, from Lecture I,

$$\frac{1}{q^2} \Rightarrow \frac{1}{q^2} + \int_{4m_e^2}^{\infty} \frac{ds}{s} \frac{\Pi(s)}{q^2 - s + i\epsilon} \quad (\text{VI. 24})$$

where $\Pi(s)$ is related to the e^+e^- annihilation cross section. The lowest order of contribution of virtual e^+e^- pairs turns out to be (Feynman, 1949)

$$\Pi(s) = \frac{\alpha}{2\pi} \left[1 + \frac{2m_e^2}{s} \right] \left(1 - \frac{4m_e^2}{s} \right)^{1/2} \quad (\text{VI. 25})$$

Accordingly, the electron-proton Coulomb interaction in position space becomes

$$-\frac{Z\alpha}{r} \Rightarrow -\frac{Z\alpha}{r} - \frac{Z\alpha}{r} \int_{4m_e^2}^{\infty} dm^2 \frac{\Pi(m^2)}{m^2} \cdot e^{-mr} \quad (\text{VI. 26})$$

At large $r \gg m_e^{-1}$, the correction term exponentially damps leaving the long-range Coulomb charge appropriate to particles of charge e and $Z|e|$. At small r the electron penetrates the polarization cloud and the interaction strength increases.

In perturbation theory for the energy shifts in the hydrogen atom the q^2 integration variable in momentum space is restricted to $q^2 \sim (Z\alpha m_e)^2$. For $q^2 \ll m_e$ one obtains from (VI. 26)

$$\frac{1}{q^2} \Rightarrow \frac{1}{q^2} \left[1 + \frac{\alpha}{15\pi m_e^2} q^2 + o\left(\frac{q^4}{m_e^4}\right) \right] \quad (\text{VI. 27})$$

$$-\frac{Z\alpha}{r} \Rightarrow -\frac{Z\alpha}{r} - \frac{(Z\alpha)\alpha}{15\pi m_e^2} 4\pi \delta^3(r) \quad (\text{VI. 28})$$

the corresponding energy shift is included in Eq. (VI. 19). Higher order binding corrections in $(Z\alpha)$ have been given by Wichmann and Kroll (1956) and are included in (VI. 22). The correction from the fourth-order vacuum polarization potential (Baranger, Dyson, and Salpeter 1952)

$$\frac{-(Z\alpha)\alpha^2}{4\pi^2 m_e^2} \left(1 + \frac{1}{81} \right) 4\pi \delta^3(r) \quad (\text{VI. 29})$$

is included in Eq. (VI. 23).

VI. 4. FINITE PROTON MASS CORRECTIONS

We now return to the relativistic Bethe-Salpeter bound-state formalism in order to extract the finite m_e/M_p corrections to the Dirac levels. In the procedure adopted by Salpeter (1952), one takes as a first approximation the instantaneous Coulomb kernel to derive the Salpeter equation. Finite mass corrections to the energy levels are then obtained from perturbations due to crossed graphs and the effects of transverse photon exchange. As the calculation proceeds, it is convenient to compare the results against the approximate Breit equation which includes the Coulomb plus instantaneous transverse potentials (Breit interaction) since the latter already contains the Dirac equation and m_e/M_p reduced mass corrections to the fine structure.

Grotch and Yennie (1969) have recently given an alternate and somewhat simpler method for determining finite proton mass correction to the Dirac levels. Their paper is very readable and we shall only sketch their results. The central idea is to introduce an effective potential into the Dirac equation which, to the desired precision, reproduces in perturbation theory

electron-proton scattering as determined from the Feynman diagram prescription. The energy eigenvalues of this effective Dirac equation should then give the energy levels of the H-atom to this same precision.

[Since the proton is treated as a free particle, it might appear that errors would occur for example in matrix elements involving the proton lower components which have a $(2M_p + k_p)^{-1} \underline{\sigma}_p \cdot \underline{P}_p$ structure [$k_p \sim O(A\alpha)^2 m_e^2 / m_p$, see Eq. (V. 3)]. The corrections, however, occur at the $(Z\alpha)^6 (m_e / M_p)^2 m_e$ level for the fine structure and at the relative order $(Z\alpha)^2 (m_e / M_p)^2$ in the hyperfine splitting. In fact, such first-order binding corrections are even included in the Grotch-Yennie equation if the effective potential is chosen to duplicate e-p scattering through two-photon exchange].

As the first approximation to the effective electron equation Yennie and Grotch take

$$\left(\underline{\alpha} \cdot \underline{p} + \beta m_e + \frac{p^2}{2M_p} + V + \frac{[\underline{\alpha} \cdot \underline{p}, V]}{2M_p} - \frac{[\underline{\alpha} \cdot \underline{p}, [p^2, Z\alpha r]]}{4M_p} \right) \psi(r) = E \psi(r) \quad (\text{VI. 30})$$

The potential includes the effect of the entire Breit interaction (Coulomb and transverse instantaneous) of the electron and nonrelativistic proton. Miraculously, the equation (up to errors in the energy levels of

$O [(Z\alpha)^4 (m_e / M_p)^2 m_e]$) can be transformed into an ordinary Dirac equation with modified parameters:

$$\left[\underline{\alpha} \cdot \underline{p} + \beta m' - \frac{Z\alpha'}{r} \right] \psi_0 = E_0 \psi_0 \quad (\text{VI. 31a})$$

with

$$m' = m_e \left[\frac{1 - E / M_p}{(1 - m_e^2 / M_p^2)^{1/2}} \right] \quad (\text{VI. 31b})$$

$$\alpha' = \alpha \left[1 - m_e^2 / M_p^2 \right]^{-1/2}$$

The eigenvalues and eigensolutions of the effective equation are related to E_0 and ψ_0 through

$$E_0 = E + (E^2 - m_e^2) / 2M_p$$

$$\psi = (1 + \beta \lambda) (1 + \lambda)^{-1} \psi_0 \quad (\text{VI. 32})$$

where $\lambda = (M_p/m_e) [1 - m_e^2/m_p^2]^{1/2}$ and E_0 is given by the usual Sommerfeld formula for the Dirac equation with m' and α' :

$$E_0 = m' f(n, j, Z\alpha') \quad (\text{VI. 33})$$

The eigenvalue E is then obtained by iteration of (VI. 32). The result is

$$E = m_e + \frac{m_e M_p}{m_e + M_p} [f(n, j, Z\alpha) - 1] - \frac{(Z\alpha)^4}{8n^4} \frac{m_e}{M_p} \cdot m_e + O\left[\left(\frac{m_e^2}{M_p^2}\right) f.s.\right] + O\left[\left(\frac{m_e}{M_p}\right) (\alpha^2/n^2) f.s.\right] \quad (\text{VI. 34})$$

This gives the expected reduced mass correction to the fine structure plus a nuclear motion correction which does not affect the relative separation of the fine-structure levels. This latter term does, however, lead to small corrections of relative order $(Z\alpha)^2 (m_e/M_p) (1/4n^2)$ to the determination of the Rydberg.

Further proton corrections, beyond what is contained in the reduced mass corrections to the fine structure and the hyperfine potential, occur from

(a) the proton form factor and anomalous moment corrections at the vertices, and

(b) corrections from multi-photon exchange amplitudes

We have already evaluated the correction due to the proton size modification of the Coulomb potential in Sec. VI. 1. The evaluation of the corrections from (b) proceeds rather similarly in Salpeter, the Grotch-Yennie procedures, and the calculations of Fulton and Martin (1954).

A correction from two-Coulomb-photon exchange, not already contained in the iteration of the effective potential (or the Coulomb potential in the Breit equation) occurs because of the finite mass of the photon. The result (to lowest order in m_e/M_p , $Z\alpha$) is

$$\Delta E_{c.c.} = -\frac{4}{3\pi} \frac{(Z\alpha)^5}{n^3} \left(\frac{m_e}{M_p}\right) m_e \delta_{\ell 0} \quad (\text{VI. 35})$$

The two-transverse-exchange photon amplitude yields the iteration of the transverse potential but also can give spin-independent $m_e^2/M_p (Z\alpha)^5$ corrections through the Thomson $\hat{\epsilon} \cdot \hat{\epsilon}'$ contribution in Compton scattering [which, we recall, arises through the $p(p\bar{p})$ intermediate states].

The result obtained by the above authors is

$$\Delta E_{TT} = \frac{2(Z\alpha)^5}{\pi n^3} \left(\frac{m_e}{M_p} \right) m_e \int_{\epsilon_0} [\log Z\alpha + \frac{7}{4} + \frac{4}{3}(1 - \log 2)] \quad (\text{VI. 36})$$

The $\log Z\alpha$ occurs because the electron wave function cuts off a logarithmic integral at $r \sim (Z\alpha m_e)^{-1}$.

The contribution of the single transverse photon exchange amplitude to all orders in Coulomb exchange is very much analogous to the electron self-energy correction. In fact from Fig. VI. 4 we can see that the transverse photon contribution is identical to the electron self-energy contribution except that the photon starts on the electron and ends on the proton or vice versa.

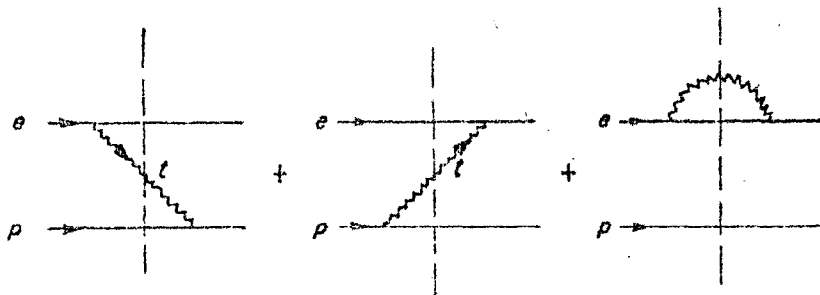

FIG. 6-4. Time-ordered second-order perturbation theory for the effect of transverse photons on the Coulomb-bound $e-p$ atom.

The old-fashioned perturbation theory contribution is quite similar to Eq. (VI. 11)

$$\Delta E_T = -\frac{2Ze^2}{(2\pi)^3} \int \frac{d^3k}{2k} \sum_m \sum_{\lambda=1,2} \frac{\langle n | \alpha_e \cdot \hat{\epsilon}_\lambda e^{ik \cdot x_e} | m \rangle \langle m | \alpha_p \cdot \hat{\epsilon}_\lambda e^{-ik \cdot x_p} | n \rangle}{E_n - E_m - k + i\epsilon} \quad (\text{VI. 37})$$

$$k = |k|$$

If we write

$$\frac{1}{E_n - E_m - k} = \frac{1}{-k} + \frac{1}{-k} (E_m - E_n) \frac{1}{E_n - E_m - k} \quad (\text{VI. 38})$$

then the first term gives exactly the Breit interaction

$$\begin{aligned} & + \frac{Ze^2}{(2\pi)^3} \int d^3k \frac{\underline{\alpha}_\perp^e \cdot \underline{\alpha}_\perp^p}{k^2} e^{ik \cdot (x_e - x_p)} \\ & = \frac{Z\alpha}{|\underline{x}|} \underline{\alpha}_\perp^e \cdot \underline{\alpha}_\perp^p, \end{aligned} \quad (\text{VI. 39})$$

which is already accounted for. For the remainder, if we only want m_e/M_p corrections we can take

$$\underline{\alpha}_p \cdot \hat{\underline{E}} e^{-ik \cdot x_p} \cong \frac{P_p \cdot \hat{\underline{E}}}{M_p} = \frac{-P_e \cdot \hat{\underline{E}}}{M_p} \quad (\text{VI. 40})$$

Also, to lowest order in $(Z\alpha)^2$

$$\underline{\alpha}_e \cdot \hat{\underline{E}} e^{ik \cdot x_e} \cong \frac{P_e \cdot \hat{\underline{E}}}{m_e} \quad (\text{VI. 41})$$

At this point we have exactly $2Z(m_e/M_p)$ times the non-relativistic approximation to the Lamb-shift expression (VI. 18). It is interesting to see that the subtraction of the Breit potential plays the same role as the mass subtraction in the self-energy correction.

For large $k \gg (Z\alpha)^2 m_e$, there is, however, considerable difference in the two calculations. In the transverse exchange contribution the retardation factor $e^{ik \cdot (x_e - x_p)}$ serves to cut off at $k \sim Z\alpha m_e$ what would be a logarithmic divergence for $k \rightarrow \infty$. The result is

$$\Delta E_T = \frac{8(Z\alpha)^5 m_e^2 / M_p}{3\pi n^3} \int_{\log} \left[\log \frac{Z\alpha m_e}{|E_n - E_{n'}|_{av}} + \frac{25}{12} \right] \quad (\text{VI. 42})$$

in contrast to the $\log (m_e/2 | \epsilon_n - \epsilon_{n'} |_{av})$ contribution for the Lamb shift in (VI. 18).

In the calculation of the Lamb shift from Eq. (VI. 11), the retardation factors are ineffective at high k since they cancel! The cut off at large k comes at $k \sim m_e$ from the (subtracting) contributions of the intermediate pair states $[E_{n'} = E_n + 2m_e + O(Z\alpha)^2]$.

Of course, if Eq. (VI. 7) is used with the Dirac bound-state propagator, these contributions are taken care of automatically.

A recent comparison with experiment is given in Brodsky and Drell, Ann. Rev. Nucl. Science, 1970.

VII. EIKONAL TECHNIQUES IN HIGH ENERGY QUANTUM ELECTRODYNAMICS

An interesting insight into the high energy behaviour of field theory has been provided in the last two years by the development of the eikonal approximation in quantum electrodynamics. The main references in this development are

- H. Cheng and T. T. Wu, Phys. Rev. 186, 1611 (1969)
 H. Abarbanel and C. Itzykson, P. R. L. 23, 53 (1969)
 M. Levy and J. Sucher, Phys. Rev. 186, 1676 (1969)
 H. M. Fried, Phys. Rev. D2, 3035 (1970)
 R. Blankenbecler and R. Sugar, Phys. Rev. D2, 3024 (1970)
 (and references therein).

The main result which has been established is that the high energy forward (or near forward) scattering amplitude can be written in an exponential phase form, with the phase given by integration over a part or ray of an effective potential. We shall find that the main techniques used for establishing this result are very similar to the methods used in Chapter III, for establishing the Dirac equation for $M_p \rightarrow \infty$.

Also, some readers will recognise that a great deal of the formalism is only a slight generalisation of the results given by D. Yennie, S. Frautshi, and K. Suura, Ann. Phys. (N. Y.) 13, 379 (1961) which demonstrate factorization of infrared photon behaviour in QED.

It will be helpful to first review the eikonal approximation in non-relativistic potential scattering. The scattering amplitude is

$$f_{kk'} = (\varphi_{k'}, V \psi_k^{(+)})$$

where $\varphi_k = N e^{ik \cdot x}$ is the free solution and $\psi_k^{(+)}$

is the outgoing wave solution of

$$\left[\frac{p^2}{2m} + V \right] \psi_k^{(+)} = \frac{k^2}{2m} \psi_k^{(+)}$$

Write

$$\frac{p^2}{2m} = \frac{(p-k)^2}{2m} + \frac{2p \cdot k}{2m} - \frac{k^2}{2m}$$

Although \hat{p} is an operator, suppose that the potential causes the effective value of $\langle p \rangle$ to deviate little from \underline{k} . Then we take

$$(\hat{p} - \underline{k})^2 \ll \underline{k}^2$$

and ($\hat{k} = \hat{z}$)

$$\left[\frac{\underline{k}}{m} \left(-i \frac{\partial}{\partial z} \right) + V(z) \right] \psi_{\underline{k}}^{(+)} = \frac{\underline{k}^2}{m^2} \psi_{\underline{k}}^{(+)}$$

The solution for $\psi^{(+)}$ with the behaviour $\psi_{\underline{k}}^{(+)} \rightarrow \varphi_{\underline{k}}$ at $z \rightarrow -\infty$ is simply

$$\psi_{\underline{k}}^{(+)} = \varphi_{\underline{k}} e^{i\eta}$$

where

$$\eta(\underline{k}) = -\frac{m}{k} \int_{-\infty}^z V(\underline{b}, \xi) d\xi$$

Thus ψ acquires an eikonal phase $\eta(\underline{b}, z)$ obtained by integration of the potential along the beam direction at impact parameter \underline{b} .

The scattering amplitude is

$$f_{\underline{k}\underline{k}'} = \int d^2b e^{i\underline{q} \cdot \underline{b}} \int_{-\infty}^{\infty} dz V(\underline{b}, z) e^{i\eta(\underline{b}, z)} e^{i\underline{q}_z z}$$

Note that $\frac{\partial}{\partial z} e^{i\eta(\underline{b}, z)} = -\frac{im}{k} V e^{i\eta(\underline{b}, z)}$

Thus for the case of $\underline{q}_z \rightarrow 0$ ($\underline{k}_z = \underline{k}'_z$) we have

$$f_{\underline{k}\underline{k}'} = -\frac{k}{im} \int d^2b e^{i\underline{q} \cdot \underline{b}} \left[e^{i\chi(\underline{b})} - 1 \right]$$

where χ is the total eikonal phase: *

$$\chi(\underline{b}) = \nu(\underline{b}, \infty) = -\frac{m}{k} \int_{-\infty}^{\infty} dz \cdot V(\underline{b}, z) dz$$

Relativistic expansions and perturbation theory corrections to the eikonal method have been discussed by many authors; see especially Blankenbecler and Sugar and Levy and Sucher.

The remarkable fact is that in quantum electrodynamics, infinite classes of a Feynman graph for high energy electron-electron scattering can be summed up to a very similar eikonal form. The most important example includes the summation of the contribution of the entire infinite series of ladder and crossed graph photon exchange diagrams (excluding radiative corrections). In the following we will use the notation and techniques of Cheng and Wu.

Consider a Feynman diagram for electron-electron scattering involving n-photon exchange.

$$q = \sum q_i = 2r_1$$

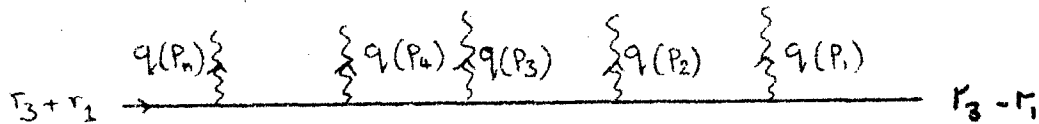
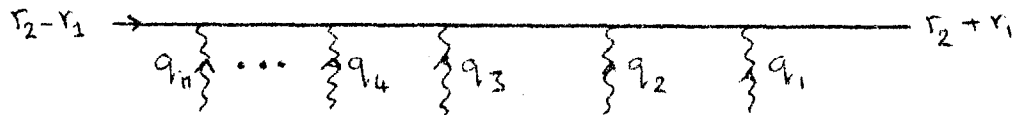

* A preferable, more accurate form is (see Levy and Sucher)

$$-\frac{m}{k} \int_0^{\infty} dz [V(\underline{b} + \hat{p}'z) + V(\underline{b} - \hat{p}z)]$$

The Feynman amplitude using the Bj.-Drell conventions is

$$M_n(P) = (-i)^{n-1} e^{2n} (2\pi)^{-4(n-1)} \int d^4q_1 \dots d^4q_n \delta^4(2r_1 - \sum q_i)$$

$$\prod_{j=1}^n \frac{1}{q_j^2 - \lambda^2 + i\epsilon} \cdot F_1 F_2 G_1 G_2$$

where

$$F_1 = \gamma_{\mu_1} [\not{r}_2 + \not{r}_1 - \not{r}_1 + m] \gamma_{\mu_2} [\not{r}_2 + \not{r}_1 - \not{r}_1 - \not{r}_2 + m] \gamma_{\mu_3} \dots$$

$$\dots [\not{r}_2 - \not{r}_1 + \not{r}_n + m] \gamma_{\mu_n}$$

$$F_2 = \gamma_{\mu(p_1)} [\not{r}_3 - \not{r}_1 + \not{r}(p_1) + m] \gamma_{\mu(p_2)} \dots$$

$$\dots [\not{r}_3 + \not{r}_1 - \not{r}(p_n) + m] \gamma_{\mu(p_n)}$$

$$G_1 = \frac{1}{(r_2 + r_1 - q_1)^2 - m^2} \dots \frac{1}{(r_2 - r_1 + q_n)^2 - m^2}$$

$$G_2 = \frac{1}{(r_3 - r_1 + q(p_{n1}))^2 - m^2} \dots \frac{1}{(r_3 + r_1 - q(p_n))^2 - m^2}$$

As noted in the figure, P is a given permutation of $i=1, \dots, n$ depending on the origin on the bottom line of the emitted photons q_1, \dots, q_n .

We shall be interested in the limit of high energy near forward scattering: $r_2 \rightarrow \infty, r_3 \rightarrow \infty, r_1$ fixed.

It is easy to verify that the convection current at each vertex gives the leading high energy behaviour, i. e. we can take

$$F_1 \rightarrow (2^{n-1}) \frac{1}{m} r_{2\mu_1} r_{2\mu_2} \dots r_{2\mu_n} \delta_{12}$$

with overall helicity conservation. For example, for $n = 2$

$$\begin{aligned} & \bar{u}(r_2+r_1) \gamma_{\mu_1} [\not{r}_2 + \not{r}_1 - \not{r}_1 + m] \gamma_{\mu_2} u(r_2-r_1) \\ & \rightarrow 2(r_2+r_1)_{\mu_1} \bar{u}(r_2+r_1) \gamma_{\mu_2} u(r_2-r_1) + O(q_1) \\ & \rightarrow 2(r_2+r_1)_{\mu_1} r_{\mu_2} \frac{\delta_{12}}{m} \end{aligned}$$

Applying the same approximation to F_2 yields

$$F_1 F_2 \rightarrow \frac{1}{(2m)^2} (4r_2 \cdot r_3)^n \delta_{12} \delta_{1'2'}$$

This is a key simplification of QED, the leading behaviour in S is obtained trivially in early order from the simplest approximation to the vertex.

At this point, the permutations only occur in G . We now shall use the CM system with $r_2 = -r_3$, $w = |r_2|$,

$$2 r_2 \cdot r_3 = S \sim 4 w^2$$

Also for each $q^{(j)}$ it is very useful to introduce

$$q_0^{(j)} = u^j + v^j \quad ; \quad q_3^{(j)} = u^j - v^j$$

$$\text{Then, } [r_2 - r_1 + q_r(p_1)]^2 - m^2$$

$$\rightarrow 2 q_r(p_1) \cdot (r_3 - r_1)$$

$$\rightarrow 4 u(p_1) w \quad \left\{ \text{with } \hat{r}_3 \text{ in the negative } \hat{z} \text{ direction} \right\}$$

so that

$$G_2 = \frac{1}{(4w)^{n-1}} \frac{1}{(u(p_1) + i\epsilon)} \frac{1}{(u(p_1) + u(p_2) + i\epsilon)} \cdots \frac{1}{(-u(p_n) + i\epsilon)}$$

& similarly

$$G_1 = \frac{1}{(4w)^{n-1}} \frac{1}{(-v_1 + i\epsilon)} \frac{1}{(-v_2 + v_1 + i\epsilon)} \cdots \frac{1}{(+v_n + i\epsilon)}$$

For the top $n-1$ denominators. Note that the crucial eikonal approximation

$\sum q^2 \ll \sum q \cdot r_3$ has already been made here. It asserts that the integrations over the q^j do not involve q^j 's of magnitude

w. We shall be able to verify this a posteriori in QED.

We now recall from Chapter III, the identity needed to prove the Dirac results:

$$\sum_P G_2(P) = \frac{1}{(4w)^{n-1}} \prod_{j=1}^{n-1} [-2\pi i \delta(u_j)]$$

It doesn't hurt to symmetrise over the indices in G_1 : (since at this point everything is symmetric).

$$G_1 = \frac{1}{n!} \sum_{\mathbb{P}} G_1(\mathbb{P}) = \frac{1}{n!} \frac{1}{(4\omega)^{n-1}} \prod_{k=1}^{n-1} [-2\pi i \delta(\mathcal{V}_k)]$$

Thus the u_j and v_j i.e. q_0^j and q_3^j , are effectively zero we have (n-1)

δ -factors: $(2) \delta(q_0^i) \delta(q_3^i)$.

Collecting all the factors,

$$\sum_{\mathbb{P}} \mathcal{M}_n(p) = (-i) (-ie^2)^n \frac{r_2 \cdot r_3}{m^2} \frac{1}{(2\pi)^{2(n-1)}} \delta_{12} \delta_{1'2'} \frac{1}{n!} \int d^2 q_{\perp 1} \dots d^2 q_{\perp n} \delta^2(2\vec{r}_1 - \sum_{j=1}^n \vec{q}_{\perp j}) \prod_{k=1}^n \frac{1}{[\vec{q}_{\perp k}^2 + \lambda^2]}$$

To see that this is just the usual eikonal result, write

$$\delta^2(2\vec{r}_1 - \sum_{j=1}^n \vec{q}_{\perp j}) \equiv \frac{1}{(2\pi)^2} \int d^2 b e^{i(2\vec{r}_1 - \sum_{j=1}^n \vec{q}_{\perp j}) \cdot \vec{b}}$$

and let

$$-\chi(\vec{b}) \equiv \int_{-\infty}^{\infty} dz V(z, \vec{b}) \equiv e^2 \frac{1}{(2\pi)^2} \int d^2 q_{\perp} e^{-i\vec{q}_{\perp} \cdot \vec{b}} \frac{1}{\vec{q}_{\perp}^2 + \lambda^2}$$

$$= e^2 \frac{1}{2\pi} K_0(\lambda b)$$

where K_0 is the Bessel function and $V = \frac{a}{r} e^{-\lambda r}$, $r^2 = \vec{b}^2 + z^2$

is the appropriate coulomb (Yukawa) potential.

Then, $(\vec{q}^2 = 2\vec{r}_1^2)$

$$\mathcal{M} = \sum_{\mathbb{P}} \mathcal{M}_n(p) = -i \frac{r_2 \cdot r_3}{m^2} \delta_{12} \delta_{1'2'} \sum_{\mathbb{P}} \frac{1}{n!} \int d^2 b e^{i\vec{q} \cdot \vec{b}} [i\chi(\vec{b})]^n$$

$$= i \frac{\tau_2 \cdot \tau_3}{m^2} \delta_{12} \delta_{1'2'} \int d^2 b e^{i \vec{q} \cdot \vec{b}} \{1 - \exp(i\chi)\}$$

which looks extraordinarily like the non-relativistic result. Cheng and Wu note that the imaginary part of the amplitude has the form

$$\text{Im } \mathcal{M} = \frac{2\tau_2 \cdot \tau_3}{(2\pi)^2} \int d^2 q_{\perp} I_{12}^e I_{1'2'}^e P_1 P_2$$

with
$$P_1 = e^{-2} \int d^2 b e^{i(\vec{r}_1 + \vec{q}_{\perp}') \cdot \vec{b}} \{1 - e^{i\chi(\vec{b})}\}$$

$$P_2 = e^{-2} \int d^2 b e^{i(\vec{r}_1 - \vec{q}_{\perp}') \cdot \vec{b}} \{1 - e^{i\chi(\vec{b})}\}$$

$$I_{12}^e = \delta_{12} \frac{e^2}{2}$$

$$I_{1'2'}^e = \delta_{1'2'} \frac{e^2}{2}$$

which yields a separate eikonal phase for each scattering particle. The factor

I_{12}^e (trivial here for the electron) generalises to other problems - especially for the case of an incident photon (in which case scattering occurs from the vacuum polarisation loop) where γ -e scattering can be summed to a similar eikonal form, but with a much more complicated

$$I_{12}^{\gamma}(\vec{q}', \vec{r}_1)$$

Cheng and Wu have also given complete results for Delbrück scattering and photon-photon scattering at high energies. E. Yao has discussed inclusion of order α radiative corrections on the electron-line. Basically, the exchanged potential is modified in the expected way by the electron form factors. For a heavy nucleus, one uses simply,

$$I^N = \frac{1}{2} \frac{1}{M} Z^2 e^2$$

Cheng and Wu have gone on to discuss the summation of a more complicated set of graphs in e-e scattering - the "tower" series.

The set of graphs

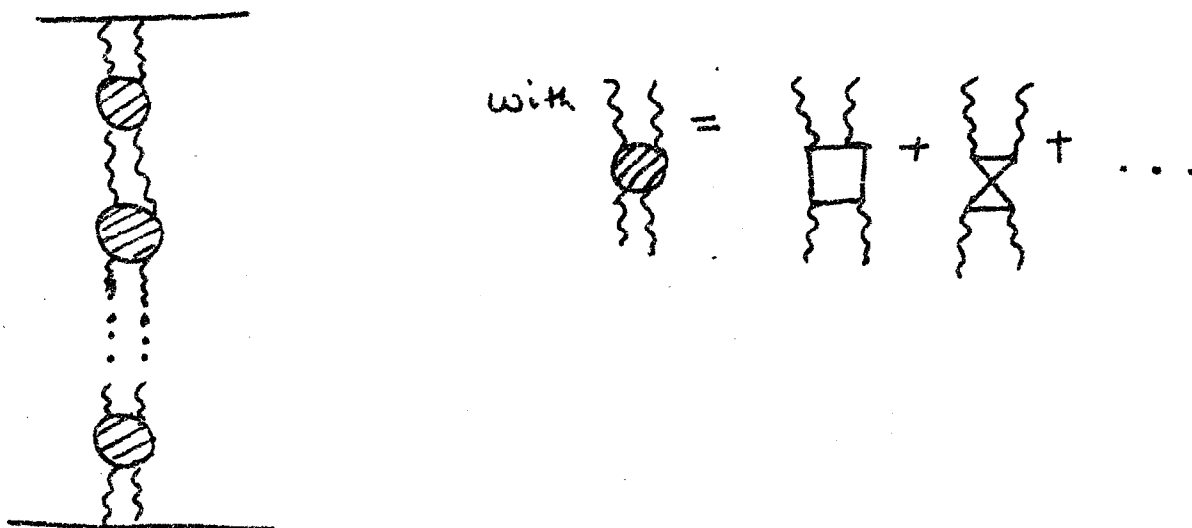

gives a form $i S^{1+a} / \log S$ at $t = 0$.

with $a = \frac{11}{32} \pi \alpha^2$.

This violates unitarity. However with further assumptions on the integration convergence, all closed permutations can be included, and a further degree of exponentiation is obtained, consistent with unitarity. The Cheng-Wu results are consistent with the usual models proposed for diffraction scattering: a logarithmically increasing cross section and a shrinking diffraction peak (corresponding to scattering from a disc whose interior becomes more absorptive as the energy increases) due to the increasing shadow of the inelastic electron-pair channels. It is not clear how directly applicable to hadron physics this is since non-vector exchange theories do not always have the property that the large momenta flow essentially through the outside legs. For applications in scalar meson theory, see B. Hasslacher, et al, P.R.L. (1970) and S. J. Chang and T. M. Yan, Phys. Rev. Letters 25, 1586, (1970), and for pseudo-meson theory (in which double meson exchange generates the eikonal potential), see C. E. Carlson and T. L. Neff - SLAC- PUB - 867 (1971).

Nevertheless it seems very interesting that diffractive scattering eventually plays a role even in QED. The fact that higher order graphs in QED yield constant cross sections (since $\text{Im } M \sim s \rightarrow \sigma_{\text{tot}} - \text{const}$) and thus can swamp the lower Born processes (which typically have $\sigma \sim 1/s$) is dramatically illustrated by recent work (see e.g. S. Brodsky, H. Terazawa, T. Kinoshita, P.R.L. 1970) in colliding beam physics, where one sees that at high energies, two photon processes can dominate over the usual annihilation cross sections in $e^+ e^-$ collisions at high energies.

A rather ambitious attempt to actually calculate bound state spectra using eikonal results has been made by E. Brezin, C. Itzykson and J. Zinn-Justin, Phys. Rev. D1 (1970) (See also M. Levy and J. Sucher, Phys. Rev. 186, 1656 (1969)). They observe that in principle, the knowledge of the scattering amplitude for forward electron-positron scattering for all s will, by analytic continuation, yield the position of the bound state poles. In fact for the case of a zero mass photon ($\lambda \rightarrow 0$) the eikonal approximation seems not to be an approximation at all. For example in the case of non-relativistic scattering on a Yukawa potential, the forward scattering amplitude has the form

$$M^{(n)} = - \left[\frac{Ze^2}{(2\pi)^3} \right]^n \int d^3 q_1 \dots d^3 q_n \delta^3(\sum \vec{q}_i) \prod_{i=1}^n \frac{1}{q_i^2 + \lambda^2} \frac{1}{\frac{2\vec{p} \cdot \vec{q}_i + q_i^2}{2m} + i\epsilon} \dots \frac{1}{\frac{2\vec{p} \cdot \sum \vec{q}_i + (\sum \vec{q}_i)^2}{2m} + i\epsilon}$$

If we change variables to

$$\vec{q}_i = \lambda \vec{q}_i$$

then we simply get

$$M^{(n)} = - \left[\frac{Ze^2}{(2\pi)^3} \right]^n (2m)^{n-1} \frac{1}{\lambda^2} \int d^3 \vec{q}_1 \dots d^3 \vec{q}_n \delta^3(\sum \vec{q}_i) \prod_{i=1}^n \frac{1}{q_i^2 + 1} \frac{1}{2\vec{p} \cdot \vec{q}_i + \lambda q_i^2} \dots$$

However for $\lambda \rightarrow 0$, we can presumably drop the λq^2 terms relative to $2\vec{p}_1 \cdot \vec{p}_1$. The eikonal result is then appropriate and we get

$$M(p) = \frac{1}{\lambda^2} \frac{iP}{m_a} \int \frac{b db}{(2\pi)^2} \left\{ e^{\frac{2imZ\alpha}{P} K_0(b)} - 1 \right\}$$

this is convergent except for $b \sim 0$ where

$$K_0(b) \sim -\log \frac{b}{2} (1 + O(b)) + O(b)$$

$$\exp \left[\frac{2imZ\alpha}{P} K_0(b) \right] \sim \left(\frac{b}{2} \right)^{-\frac{2imZ\alpha}{P}}$$

Thus, just like the gamma function,

$$\Gamma(z+1) = \int_0^\infty db e^{-b} b^z$$

$M(p)$ has simple poles at $P = P_n = \frac{imZ\alpha}{n}$, or $E_n = \frac{P_n^2}{2m} = -\frac{(Z\alpha)^2 m}{2n^2}$

For the case of a relativistic Klein-Gordon particle,

$$[(E-V)^2 - \vec{p}^2 - m^2] \psi = 0$$

If one drops the V^2 terms this is a Schrödinger equation of the form

$$\left[\frac{\vec{p}^2}{2E} + V \right] \psi = \left(\frac{E^2 - m^2}{2E} \right) \psi$$

The same eikonal trick then yields

$$E_n = \frac{m}{\sqrt{1 + \frac{Z^2 \alpha^2}{n^2}}}$$

where $n = n' + l + 1$, $n' \geq 0$

for each degenerate angular momentum state l . The $V^2 = (Z\alpha)^2/r^2$

term could be included in the radial equation for ψ if we'd formally change $l(l+1)$ to $l(l+1) - (Z\alpha)^2 = \tilde{l}(\tilde{l}+1)$

This effectively changes $l \rightarrow \tilde{l}$, and

$$n \rightarrow n - \epsilon_l, \quad \epsilon_l = l + \frac{1}{2} - \sqrt{\left(l + \frac{1}{2}\right)^2 - Z^2\alpha^2}$$

This replacement gives the correct Klein-Gordon spectrum.

In fact, Itzykson has shown that a similar trick also works rigorously for the Dirac spectrum taking j instead of l in the above.

Finally, one is tempted to look at the poles in the eikonal amplitude for forward electron-positron scattering. For the case of two spin zero particles of masses m_1 and m_2 and charges e and $-Ze$, the corresponding limit for forward scattering is (in cm)

$$\mathcal{M}(s) = \lim_{\lambda \rightarrow 0} \frac{i |\vec{P}| (p_1^0 + p_2^0)}{m_1 m_2} \frac{1}{\lambda^2} \int \frac{d^2b}{(2\pi)^2} \left[\exp \frac{2i(Z\alpha) P_1 \cdot P_2}{|\vec{P}| (p_1^0 + p_2^0)} K_0(b) - 1 \right]$$

with poles at energies given by

$$S_n = m_1^2 + m_2^2 + \frac{2m_1 m_2}{\left[1 + \frac{Z^2\alpha^2}{n^2}\right]^{1/2}}$$

(this in fact gives the result $E_n = m_1 / \sqrt{1 + Z^2\alpha^2/n^2}$ for $m_2 \rightarrow \infty$)

Since seagulls were not included in the scattering amplitude, it would seem likely that again we should use the $n \rightarrow n - \epsilon_j$ trick to include the spin-dependent terms, and hence obtain the relativistic Balmer formula of Brezin, et al :

$$S_n = m_1^2 + m_2^2 + \frac{2m_1 m_2}{\left[1 + Z^2\alpha^2/(n - \epsilon_j)^2\right]^{1/2}}$$

a result suited for the spin $\frac{1}{2}$ case as well.

It is then quite interesting to compare the result with the known Bethe-Salpeter results for positronium, etc. (of course neglecting radiative corrections on the lepton lines and vacuum polarisation). In fact the fs results are correct through order $(Z\alpha)^4$ for two spin $\frac{1}{2}$ particles, but the formula clearly misses the known order

$$(Z\alpha)^5 m_1/m_2 [\log Z\alpha, 1]$$

terms from the Bethe-Salpeter equation (e. g. energy retardation corrections to the one-traverse photon interaction). The essential point is that by its nature the eikonal approximation only retains the longest range $1/r$ part of the photon exchange effects, and misses the detailed short range corrections implicit in the covariant treatment.

The recent results of A. Nandy and R. Sawyer (to be published) cast further doubt on whether the eikonal approach will serve usefully as the starting point to the bound state problem). They find that the actual Bethe-Salpeter calculation of the bound state spectra for two spin zero particles (including seagull contributions) even in order $(Z\alpha)^4 m_1/m_2$ if $l \neq 0$. Thus it is clear that the heuristic derivation of Brezin et al (which in fact ignores short-range forces) is inadequate. However, it may in fact turn out that the eikonal approximation is in fact a convenient initial approximation to incorporate the longest range Coulomb parts of the binding interaction. A systematic effective potential method which correctly handles the short-range terms has recently been given by I. Todorov [Phys. Rev. D, 1971] .

VIII. INELASTIC ELECTRON SCATTERING IN FIELD THEORY

(a) Brief Introduction and kinematic survey :

In the last part of this course we shall discuss one of the most promising and exciting areas of hadronic physics - deep inelastic electron proton scattering. The recent data from the high energy electron accelerators at SLAC and DESY seem to be indicating a new unexpected composite structure of the proton and neutron. The new tool of study, large space-like photon mass and large inelasticity, combined with the local structure of the electromagnetic current, provides a sharp probe of hadron structure at short distance.

We shall first briefly recall the experimental situation for elastic electron-nucleon scattering. To lowest order in α , the scattering matrix element is proportional to

$$\langle P' | J_1(0) | P \rangle = \sqrt{\frac{2\omega'}{17m^2EE'}} u(P') \left[\gamma_4 F_1(q) + \frac{(\not{P} + \not{q}) \gamma_4 (\not{P} - \not{q})}{2m} \frac{\kappa F_2(q)}{2m} \right] u(P)$$

with

$$P'^2 = (P+q)^2 = m^2 + q^2 + 2P \cdot q = m^2$$

$$q^2 = -Q^2 = -2P \cdot q = -2EE' (1 - \cos\theta) = -4EE' \sin^2 \frac{\theta}{2}$$

The cross section is the Rosenbluth formula

$$(m^2 \ll E^2, E'^2)$$

$$\frac{d\sigma}{d\Omega} = \frac{E'}{E} \frac{Q^2}{4E^2 \sin^2 \frac{\theta}{2}} \left[\frac{G_E^2 + \tau G_M^2}{1 + \tau} \cos^2 \frac{\theta}{2} + 2\tau G_M^2 \sin^2 \frac{\theta}{2} \right]$$

where $\tau = \frac{Q^2}{4m^2} = -\frac{q^2}{4m^2} > 0$

Experimentally,

$$\frac{G_M(q^2)}{G_E(q^2)} = \frac{F_1 + \kappa F_2}{F_1 - \tau \kappa F_2} \approx 2.79 \quad \left(\begin{array}{l} \text{scaling} \\ \text{law} \end{array} \right)$$

and

$$G_E(q^2) \approx \frac{1}{\left(1 + \frac{Q^2}{0.71(GeV)^2}\right)^2} \quad \left(\begin{array}{l} \text{dipole} \\ \text{law} \end{array} \right)$$

Thus for Q^2 beyond several GeV^2

$$\left(\frac{d\sigma}{d\Omega}\right)_{\text{expt}} \approx \left(\frac{d\sigma}{d\Omega}\right)_{\text{point}} \times \frac{1}{q^8}$$

a rather severe fall-off. This is also characteristic for the inelastic production of specific nucleon resonance states N^* with

$$2 P \cdot q = 2 m \nu = Q^2 + M_{\text{res}}^2 - m^2$$

(ν is the lab energy loss); the cross sections are again found to fall off rapidly in momentum transfer. The regions of interest are

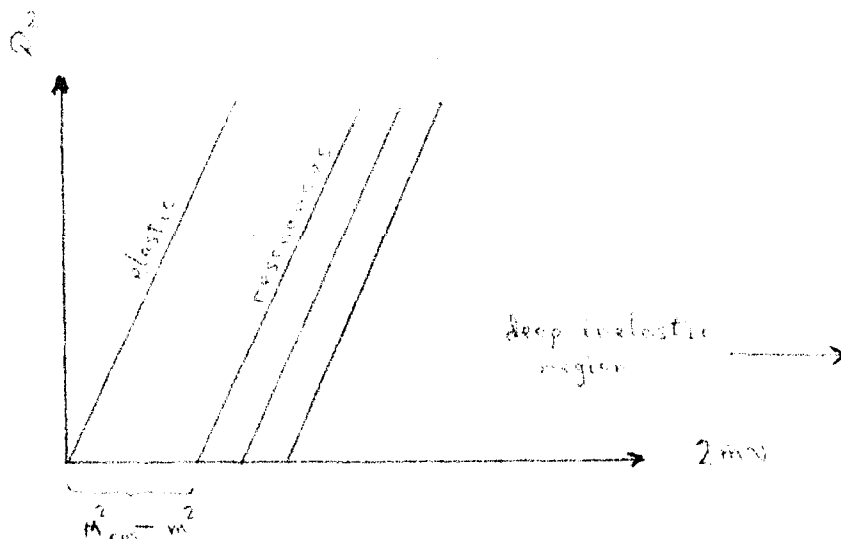

More generally we consider the inelastic processes

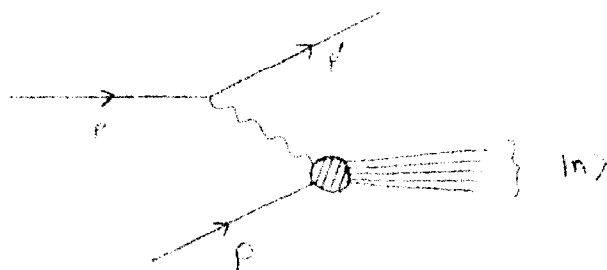

which involves the square of the lepton current

$$\frac{1}{4} \text{Tr} [\not{p}' \gamma_\mu \not{p} \gamma_\nu] = \not{p}' \not{p}_\mu + \not{p} \not{p}'_\nu - g_{\mu\nu} \not{p}' \not{p}$$

and the square of the hadron current

$$W_{\mu\nu}^{(n)} = 4\pi^2 \frac{E_f}{m} \sum_{\text{spin}} \langle P | J_\mu(\omega) | n \rangle \langle n | J_\nu(\omega) | P \rangle (2\pi)^4 \delta^{(4)}(q + P - P_n)$$

In general, experiments at high energies have thus far only involved detecting the scattered electron (single arm spectrometer experiments), only specifying q^2 , ν , but not the specific state $|n\rangle$

Thus what is observed is

$$\begin{aligned} W_{\mu\nu} &= \sum_n W_{\mu\nu}^{(n)} \\ &= - \left(g_{\mu\nu} - \frac{q_\mu q_\nu}{q^2} \right) W_1(q^2, \nu) \\ &\quad + \frac{1}{m^2} \left(P_\mu - \frac{P \cdot q}{q^2} q_\mu \right) \left(P_\nu - \frac{P \cdot q}{q^2} q_\nu \right) W_2(q^2, \nu) \end{aligned}$$

The above form for the inelastic tensor is dictated from conservation of current and the sole availability of the 4-vectors P and q .

We note for future reference that $W_{\mu\nu}$ is related via the optical theorem to the forward Compton amplitude $T_{\mu\nu}$ for virtual photon (q^2) - proton scattering.

To order α , the covariant form for inelastic e-p scattering is ($m_e \ll E^2, E'^2$)

$$\begin{aligned} \frac{d\sigma_{e+p \rightarrow e + \text{all}}}{dQ^2 d\nu} &= - \frac{4\pi\alpha^2}{Q^4} \left\{ W_2(\nu, Q^2) \left[1 - \frac{\nu}{p \cdot P} - \frac{Q^2 m^2}{4(p \cdot P)^2} \right] \right. \\ &\quad \left. + W_1(\nu, Q^2) \left[\frac{Q^2}{2(p \cdot P)^2} \right] \right\} \end{aligned}$$

and in the lab ($p = (m, 0)$).

$$\frac{d^2\sigma}{d\Omega dE'} = \frac{\omega^2}{4E^2 \sin^2 \frac{\theta}{2}} \left[W_2(\nu, Q^2) \cos^2 \frac{\theta}{2} + 2 W_1(\nu, Q^2) \sin^2 \frac{\theta}{2} \right]$$

Comparing with the Rosenbluth formula, we can read off the single nucleon $|n\rangle = |P'\rangle$ contribution:

$$W_2^{\text{proton}} = \frac{G_\pi^2 + \tau G_m^2}{1 + \tau} \delta\left(\nu + \frac{q^2}{2m}\right)$$

$$W_1^{\text{proton}} = \tau G_m^2 \delta\left(\nu + \frac{q^2}{2m}\right)$$

However in the deep inelastic region

$$\nu \gtrsim 2 \text{ GeV}^2, \quad Q^2 \gtrsim 1 \text{ GeV}^2$$

(beyond the resonances), instead of falling dramatically, the data show that W_1 and W_2 have a quite slow dependence on ν, q^2 .

This is beautifully illustrated in figure (8-1), where the rate of the inelastic cross-section to that of a hypothetical point proton (with $W_2 = W_1 = 1$) is shown (from SLAC data: M. Briedenback, et al Phys. Rev. ¹ Letters 23, 935 (1969)), and compared with a similar ratio for the elastic cross section. The inelastic cross sections are given for specific values of invariant mass squared

$$W^2 = 2m\nu - Q^2 + m^2$$

as a function of Q^2 . Thus the first striking result is that the data is qualitatively point-like.

An equally important observation, is that the data (to good experimental accuracy) shows that the deep inelastic form factors have the scale-invariant feature of only depending on the ratio of $m\nu$ and q^2 . This is the realisation of the limit proposed by Bjorken in 1966:

$$\lim_{\substack{\nu \rightarrow \infty \\ \text{fixed } \omega = \frac{2m\nu}{Q^2}}} \begin{cases} m W_1(\nu, Q^2) & = & F_1(\omega) \\ \nu W_2(\nu, Q^2) & = & F_2(\omega) \end{cases}$$

where F_1 and F_2 are finite (dimensionless) functions of the variable $\omega = -2m\nu / q^2$

At this point we should note that W_1 and W_2 must obey kinematic restrictions in order to avoid kinematic poles in $W_{\mu\nu}$ at $q^2 \rightarrow 0$.

Clearly we require

$$\begin{aligned} W_2(\nu, q^2) &= q^2 w_2(\nu, q^2) \\ W_1(\nu, q^2) + \frac{\nu^2}{q^2} W_2(\nu, q^2) &= q^2 w_1(\nu, q^2) \end{aligned}$$

where w_1 and w_2 are kinematic-singularity free form factors.

It is also convenient to define effective total - "γ" - p cross sections for virtual photon absorption. Replacing the lepton amplitude by

$$E_L^r = \frac{1}{\sqrt{Q^2}} (q_2, 0, 0, q_0)$$

and

$$E_T^r = \frac{1}{\sqrt{2}} (0, 1, \pm i, 0)$$

and using (by convention) a flux factor corresponding to real photons gives positive cross-sections (Hand)

$$\sigma_T(\nu, Q^2) = \frac{4\pi^2\alpha}{\nu - \frac{Q^2}{2m}} W_1(\nu, Q^2)$$

$$\sigma_L(\nu, Q^2) = \frac{4\pi^2\alpha}{\nu - \frac{Q^2}{2m}} \left[W_2 \left(1 + \frac{\nu^2}{Q^2} \right) - W_1 \right]$$

Note that $\sigma_L \sim q^2$ as $q^2 \sim 0$, and $W_1(\nu, q^2)$ is positive. Also, as it should $\sigma_T(\nu, 0)$ is the real total photoabsorption cross section.

Experimentally, σ_L/σ_T is found to be small in the deep inelastic region ($R = \sigma_L/\sigma_T \sim 0.18$). A typical scaling result for the deep inelastic form factor W_2 is shown in figure 8-2.

(b) Analogy in Nuclear Physics :

It will be quite useful to recall the physics of inelastic electron-nuclear scattering. The nuclear matrix element for scattering on the ground state nucleus indicated as $|p\rangle$ to an excited state $|n\rangle$ is

$$m_\mu \sim \frac{e^2}{Q^2} \int \langle n | j_\mu(x) | p \rangle e^{iq \cdot x} d^3x$$

Since $q_0 \sim \underline{q}^2/2M$ is small, $Q^2 \cong \underline{q}^2$ and the $\mu = 0$ current is dominant,

Disallowing pair production processes and proton structure, the current can be taken as the sum of local proton currents :

$$j_0(x) = \sum_{j=1}^Z \delta^{(3)}(x - z_j)$$

$$m_0 = \frac{e^2}{Q^2} \sum_j \langle n | e^{iq \cdot z_j} | p \rangle$$

and one finds

$$\frac{d\sigma}{d\underline{q}^2 d\nu} = \frac{4\pi\alpha^2}{\underline{q}^4} \sum_n \delta(\nu + E_p - E_n) \sum_{ij} \langle p | e^{iq \cdot z_i} | n \rangle \langle n | e^{-iq \cdot z_j} | p \rangle$$

If we do not detect the final state, and the limits of the spectrum $E_n - E_p$ are included in the range of ν , we use closure to get

$$\frac{d\sigma}{d\underline{q}^2} = \frac{4\pi\alpha^2}{\underline{q}^4} \langle p | e^{iq \cdot (z_i - z_j)} | p \rangle$$

$$= \frac{4\pi\alpha^2}{\underline{q}^4} [Z + Z(Z-1) f_2(\underline{q}^2)]$$

where $f_2(q^2)$ is the two-body correlation function. Generally f_2 is small for $q^2 \gg R_{sep}^{-2}$, where

R_{sep} is the mean internucleon-separation. Thus for $q^2 \gg (200 \text{ MeV})^2$,

$$\frac{d\sigma}{dq^2} \approx \frac{4\pi\alpha^2}{(q^2)^2} Z^2$$

Thus the area under the inelastic scattering curve - including continuum states of the nucleus at q^2 fixed is just Z -times the point nucleon cross section.

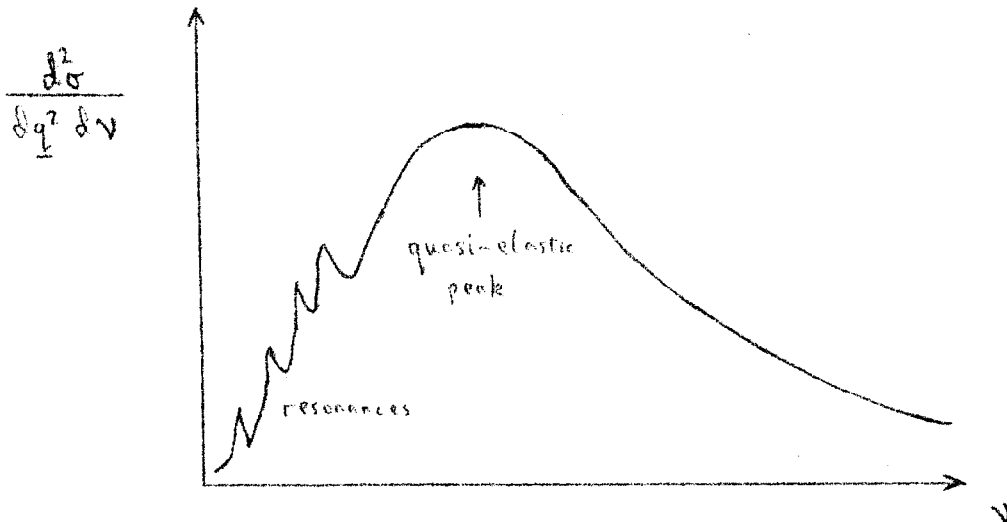

The spectrum also shows a quasi-elastic peak at

$$\nu \approx \frac{|q^2|}{2m}$$

spread, however, by the Fermi-motion of the nucleons.

Of course, the nucleons appear point-like here since we are working in the range of q^2 and energy ν where we need not consider form factors nor meson-production. Ignoring this we may say that for sufficiently large energies and momentum transfers, binding forces and correlations may be ignored, and the scattering is derived from the sum of scattering on individual target (point-like) nucleons.

The main question for proton physics is whether there is a comparable incoherent impulse approximation region which may yield a sign of scattering on possible constituents of the nucleon itself. The new experimental results do seem to be consistent with a picture of the composite nucleon, with components which display little sign of structure or form factors in the large range of Q^2 and ν which has been studied. However there is no clear sign of a quasi-elastic peak and the integral

$$\int_{\nu_{min}}^{\infty} d\nu W_2(\nu, q^2)$$

which might be expected to tell of the number of charged constituents (times the average charge squared) is apparently very large or even divergent. As a final point illustrating the impulse approximation, and the incoherence limit, consider elastic Compton scattering on the nucleus. At threshold, the amplitude is

$$\lim_{\nu \rightarrow \infty} f(\nu, \underline{q}) = \frac{(Ze)^2}{M_A}$$

At high energies ($\nu \gg$ B.E., but well below meson production thresholds)

$$f(\nu, \theta) = \sum_{i=1}^Z e^{i \underline{q} \cdot \underline{r}_i} \frac{e^2}{m_p} \underset{\underline{q} \rightarrow 0}{=} \frac{Ze^2}{m_p}$$

This is the (coherent) impulse approximation: the photon scattering takes place in a time interval ν^{-1} much shorter than the time for nuclear effects $\tau = (\text{B.E.})^{-1}$. Additionally, for large angles $|\underline{q}|^2 \gg R_{sep}^{-2}$, the amplitudes all add incoherently,

$$\frac{d\sigma}{d\Omega} = Z \frac{\sigma^2}{m_p^2} \quad (\text{incoherent})$$

$$(\nu \gg \text{B.E.} ; \quad |\underline{q}|^2 \gg R_{sep}^{-2})$$

Of course, at still larger q^2 and ν , form factor and meson production modifications of the Compton amplitude need to be taken into account. (see especially work on shadowing corrections to high energy γ -A interactions due to vector meson production, e. g. D. R. Yennie and K. Gottfried - S. Brodsky and J. Pumplin Phys. Rev. 1968)

IX. THE PARTON MODEL IN FIELD THEORY *

In this chapter we will discuss the application of field theory to inelastic electron-nucleon scattering. Most of the results in this context have been obtained by S. Drell, D. Levy and T. M. Yan in a remarkable series of papers, (See Phys. Rev. 187, 2159 (1969), D1, 1035 (1970), I, 1617 (1970), I, 2402 (1970), and Ann. Phys. (N.Y.) 1971). Many of the results had also been obtained previously on intuitive grounds by R. P. Feynman (unpublished, and Phys. Rev. Letters 23, 1415 (1969) and by J. Bjorken and E. Paschos, Phys. Rev. 185 1975 (1969). An extremely helpful introduction has been given by S. Drell in his lectures at the "Ettore Majorana International Summer School" Erice, July 1969 and SLAC - PUB - 689.

The basic goal in the field theory approach is to try to understand

- (1) whether there is an impulse approximation in renormalisable field theory which can be deduced from perturbation theory,
- (2) whether impulse approximations could possibly display the point-like structure of the bare currents in the theory,
- (3) whether other predictions, especially the analytic continuation to $q^2 > 0$ for e^+e^- annihilation can be made.

* The approach used here is based on work with J. Guion and F. Close at SLAC. I am also indebted to D. R. Yennie for helpful suggestions.

Thus we assume that the nucleon is the ground state solution of a local renormalisable field theory. The bare current is taken as the sum of contributions from the charged fields ("partons"),

$$j_{\mu}(x) = \sum_{a=1}^n \lambda_a j_{\mu}^a(x)$$

and satisfies the free particle equation of motion

$$\dot{j}_{\mu}(x) = i [H_0, j_{\mu}(x)]$$

The Heisenberg current obeys the full equations of motion

$$\dot{J}_{\mu}(x) = i [H_I, J_{\mu}(x)]$$

where (neutral) binding fields are included in $H_I = H - H_0$.

As usual we choose

$$J_{\mu}(x, 0) = j_{\mu}(x, 0)$$

at time = 0, and find

$$J_{\mu}(x, t) = U^{-1}(t) j_{\mu}(x, 0) U(t)$$

where

$$U(t) = e^{-iH_0 t} e^{iH t} = T e^{i \int_0^t d\tau H_I(\tau)}$$

satisfies

$$\dot{U}(t) = i H_I(t) U(t)$$

with

$$H_I(t) = e^{-iH_0 t} H_I e^{iH_0 t}$$

In our calculations we shall require matrix elements of the current:

$$\langle P | J_{\mu}(x) | n \rangle = e^{i(E_P - E_n)t} \langle P | j_{\mu}(x, 0) | n \rangle$$

In general, this is complicated to evaluate directly since the states

$|n\rangle$ and $|P\rangle$ are fully dressed by H_I .

Thus we use the expansion

$$\begin{aligned} |P\rangle &= U^{\dagger}(\infty) |P_0\rangle \\ &= \sqrt{Z_2} \left\{ |P_0\rangle + \sum_m' \frac{|m_0\rangle \langle m_0 | H_I | P \rangle}{E_P - E_m + i\epsilon} \right. \\ &\quad + \sum_{m, r}' \frac{|r_0\rangle \langle r_0 | H_I | m_0 \rangle \langle m_0 | H_I | P \rangle}{(E_P - E_m + i\epsilon)(E_P - E_r + i\epsilon)} \\ &\quad \left. + \dots \right\} \end{aligned}$$

in terms of the bare state (constituents) of the physical proton state. This is of course the rule for calculation of matrix elements in time-ordered "old fashioned" perturbation theory. The states $|P_0\rangle$, and $|m_0\rangle$ represent the free particle expansion of the state $|P\rangle$, and can be further classified in terms of particle number. (The sum prime indicates exclusion of the $|P_0\rangle$ state). Z_2 is the usual (re)-normalisation constant which maintains the normalisation of the state $|P\rangle$. The matrix element of \hat{H}_I between the bare states is given by the usual Born point-like results. Because the intermediate states are on-shell and of definite particle number, the OFPT is the most convenient form for investigating the question of impulse approximation, etc.

An intuitive guess for the validity of impulse approximation is that at high energies the forward Compton amplitude on the nucleon reduces to OFPT diagrams of the type (a) and (b)

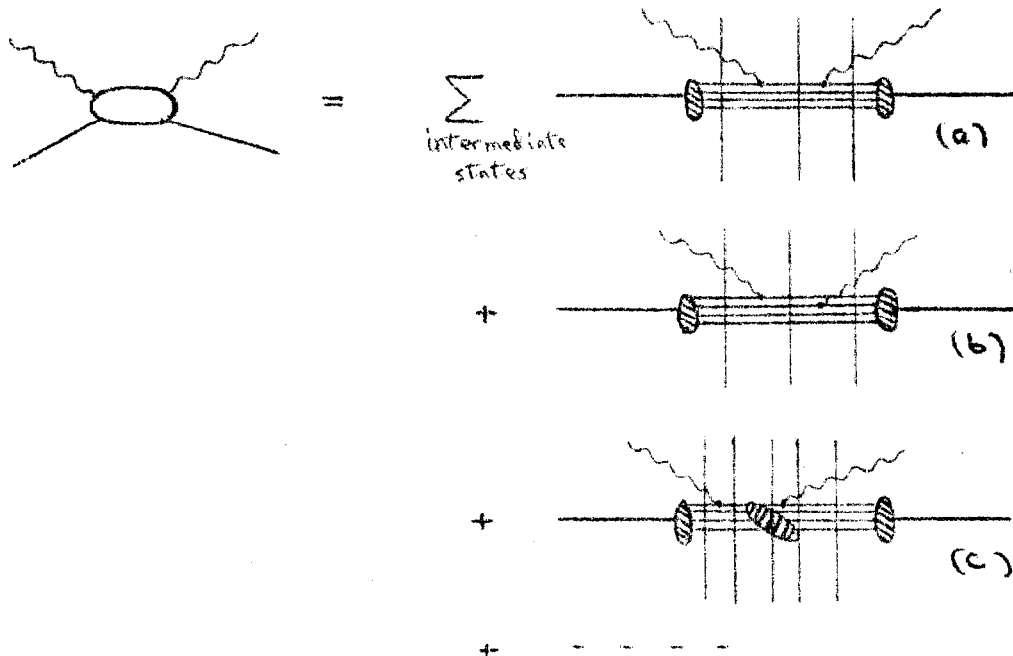

but that OFPT diagrams like (c) - involving at least one binding interaction occurring between the times of interaction of the two photons will be small in the high energy limit. [Type (a) also includes boson current seagull contributions to the real part of the Compton amplitude.] Since the form factors W_1 and W_2 or $\sigma_{S,T}(\nu, q^2)$ are obtained from the imaginary part of the forward amplitude, an impulse approximation for deep inelastic electron-proton scattering would emerge. Furthermore if the photon mass $|q^2|$ is large, there will be negligible probability for impulse diagrams like (b) to contribute unless H_I has matrix elements which give the wave functions of the constituents unreasonably large relative momenta.

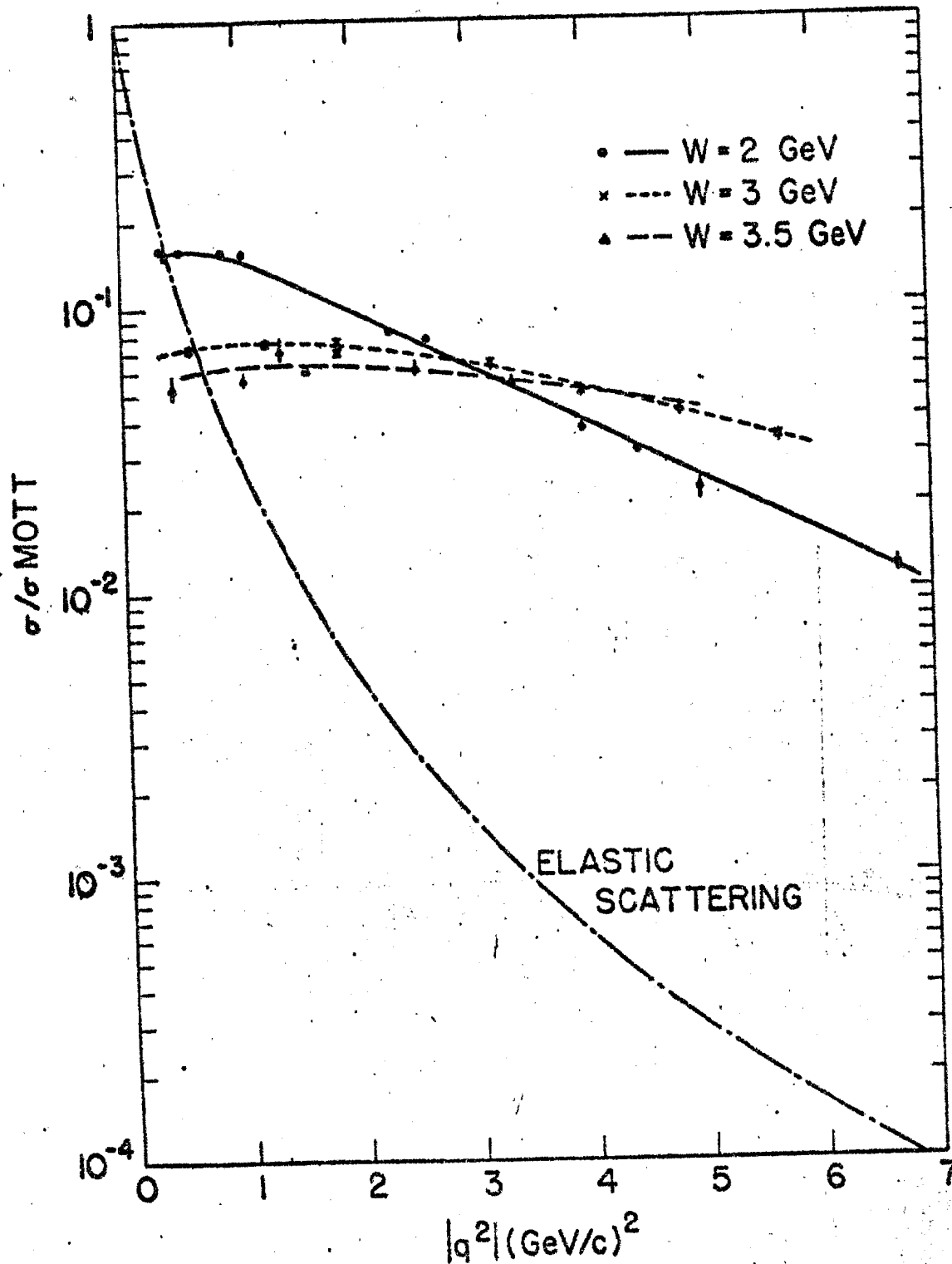

Fig. 2 $(\sigma/\sigma_{Mott})^{Yp} = W_2 + 2W_1 \tan^2 \theta/2$ plotted against $|q^2|$
at fixed missing mass W .
(8-1)

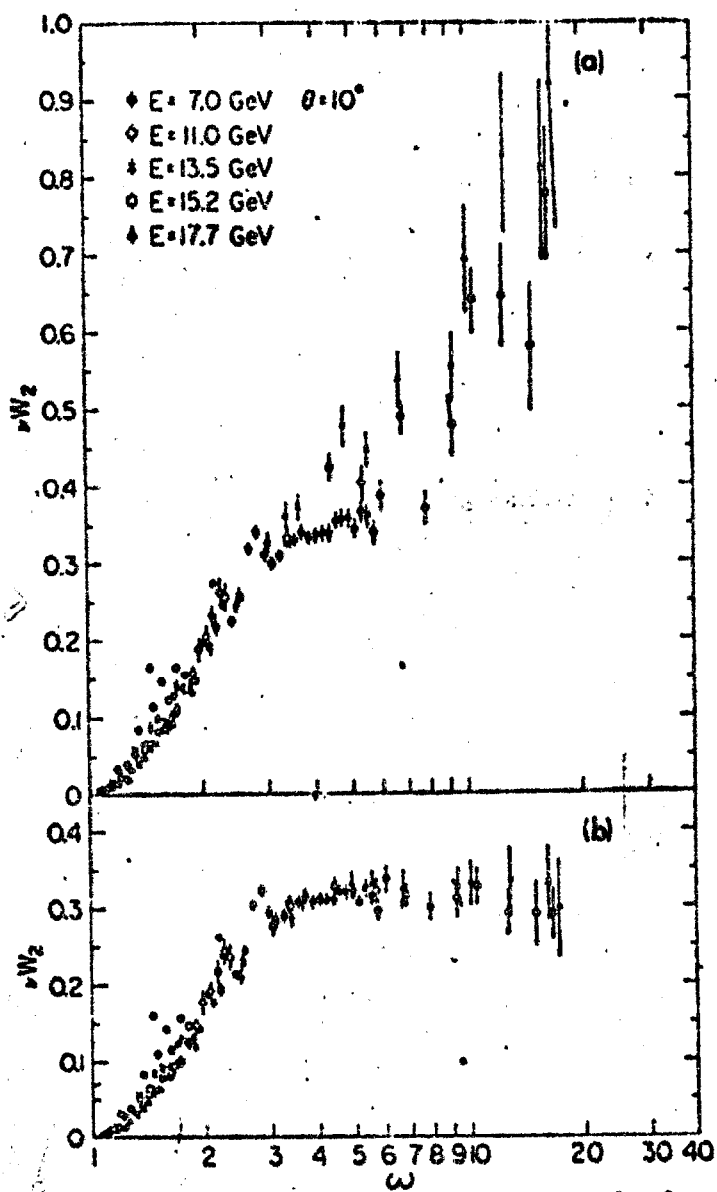
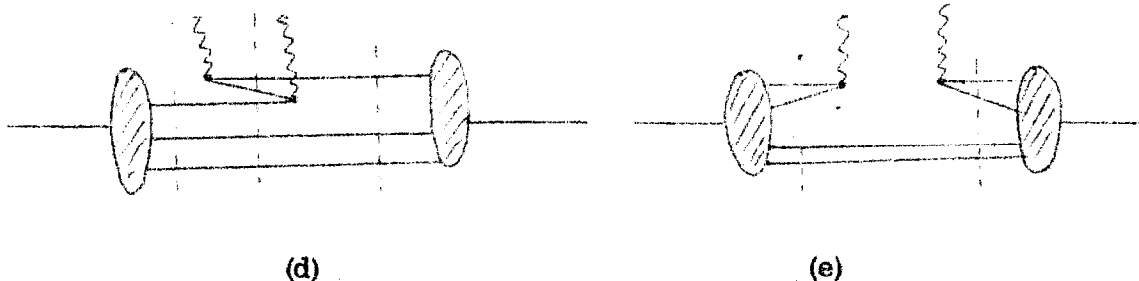

Fig. 3 νW_2^{YP} (deduced from $\theta = 10^\circ$ data assuming (a) $\sigma_L/\sigma_T = \infty$, (b) $\sigma_L/\sigma_T = 0$) plotted against $\omega = 2\nu/Q^2$.

fig 8-2

This would then be the desired impulse approximation with incoherence, yielding inelastic cross-sections from the sum of individual point-like scattering off the "parton" bare charged constituents.

There is, however, a technical difficulty in carrying out the above heuristic programme. The current in relativistic field theory has pair-creating matrix elements. Thus we must contend with additional "z-graphs" like



which have less intuitive appeal. However, as emphasised by S. Weinberg [P.R. 150, 1313 (1966)] an incredible simplicity occurs if we use OFPT_h in a reference frame with arbitrarily large ("infinite") total momentum. In this case only a relative few of all the possible time orderings which contribute to the covariant result survive, and in fact, each time-ordered perturbation theory contribution to the amplitude has a covariant form. In particular, for spin 0 lines, z-graph contributions can be dismissed altogether! In the spin $\frac{1}{2}$ theory some z-graph contributions survive, but give a simple limiting real form [as in diagram (d) which is important for forward compton scattering. It should be emphasised that the co-momentum frame method is just a reference frame device and has nothing to do with the scale of the covariant kinematic variables in the process.

As the simplest non-trivial example, consider the calculations of the elastic form factor of a spin zero particle:

$$\langle P' | J_\mu(0) | P \rangle = \frac{1}{(2\pi)^3} \frac{1}{2E_P} \frac{1}{2E_P} F(q^2) (P+P')^\mu$$

We shall calculate $F(q^2)$ through order g^2 from a neutral scalar exchange interaction. The Feynman diagrams are

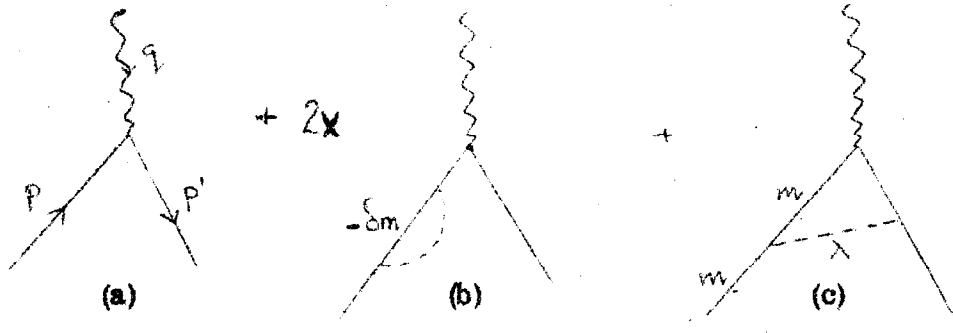

The time-ordered graphs corresponding to (c) are

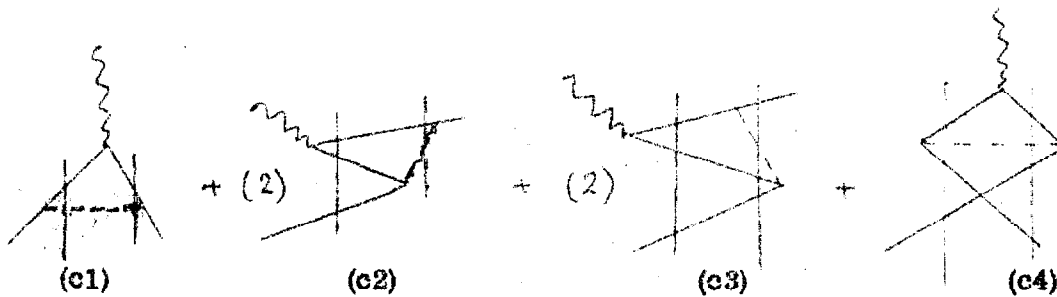

In general we would need to sum all 3 ! individually non-covariant term to get the corresponding Feynman result for (c). However, using a reference frame where

$$P = (\sqrt{E^2 + m^2}, \vec{0}, P) \cong (P + \frac{m^2}{2P}, \vec{0}, P)$$

and

$$q = \left(\frac{mV}{2P}, \vec{q}_\perp, -\frac{mV}{2P} \right), \quad q_\perp^2 = Q^2 = -q^2$$

[where we still satisfy $p^2 = m^2$, $p \cdot q = mV$ for $P^2 \rightarrow \infty$; of course $2mV = Q^2$ for elastic scattering].

Then it is easy to see that diagrams with even one backward moving particle (rel. to $\hat{p} = \hat{z}$) in an intermediate state leads to an energy denominator

$$\frac{1}{q_0 + E_p - E_n} \sim O\left(\frac{1}{P}\right)$$

whereas if all the intermediate particles move forward - as in diagram c1 if $0 < x < 1$ as defined below - then the leading P terms in the energies cancel leaving

$$\frac{1}{q_0 + E_p - E_n} \sim O(P)$$

Note, that as defined, q introduces small longitudinal momentum relative to P .

For spin 0 currents and scalar interactions, all the numerators in the 6 time-ordered contributions have the same P dependence. Thus only the "non-z" diagram c1 survives. In detail, the energy denominators (using 3-momentum conservation and the mass shell).

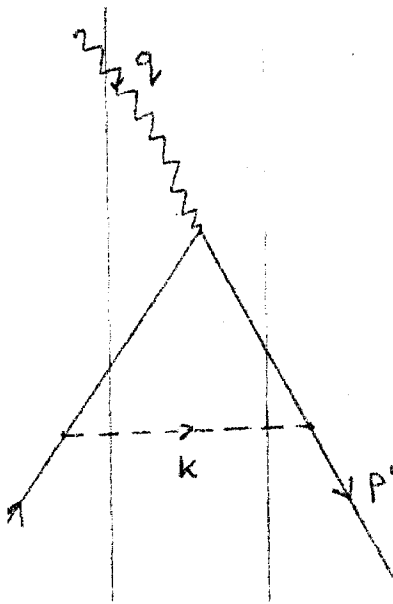

$$k = \left((1-x)P + \frac{\vec{k}_1^2 + \lambda^2}{2(1-x)P}, \vec{k}_1, (1-x)P \right)$$

$$P_1 = \left(xP + \frac{\vec{k}_1^2 + m^2}{2xP}, -\vec{k}_1, (1-x)P \right)$$

$$P_2 = \left(xP - \frac{m^2}{2P} + \frac{(\vec{k}_1 - \vec{q}_1)^2 + m^2}{2xP}, \right.$$

$$\left. -\vec{k}_1 + \vec{q}, xP - \frac{m^2}{2P} \right)$$

$$0 < x < 1$$

$$\frac{1}{q_0 + E_p - (q_0 + E_{p_1} + E_K)} = \frac{1}{P + \frac{m^2}{2P} - \left((1-x)P + \frac{\vec{k}_1^2 + \lambda^2}{2(1-x)P} + xP + \frac{\vec{k}_1^2 + m^2}{2xP} \right)}$$

$$\equiv \frac{2P}{A}$$

$$\frac{1}{q_0 + E_p - (E_{p_2} + E_K)} = \frac{2P}{m^2 + 2m\nu - \frac{\vec{k}_1^2 + \lambda^2}{(1-x)} - \frac{(\vec{k}_1 - \vec{q})^2 + m^2}{x}}$$

$$\equiv \frac{2P}{A'}$$

Note that if $x > 1$ or $x < 0$, the P terms would not cancel.
The phase space is

$$\frac{1}{(2\pi)^3} \int \frac{d^3k}{2k_0} \frac{1}{2P_{10}} \frac{1}{2P_{20}} \Rightarrow \frac{1}{(2\pi)^3} \int d^2k \int_0^1 \frac{dx}{2(1-x)} \frac{1}{(2xP)^2}$$

and the numerator, for the choice $\mu = 0$ is $P_{10} + P_{20} \Rightarrow 2P(1-x)$.

The resulting covariant amplitude is correctly linear in P and to order q^2 we identify

$$F(q^2) = \frac{1}{1 - B_{(2)}} + \frac{g^2}{(2\pi)^3} \int_0^1 dx \int \frac{d^2k}{2x(1-x)} \frac{1}{A} \frac{1}{A'}$$

$$= \frac{1}{1 - B_{(2)}} + \frac{g^2}{16\pi^3} \int_0^1 dx \int \frac{d^2k}{D(\vec{k}^2) D(\vec{k}')^2} x(1-x)$$

where

$$D(\vec{k}^2) = \vec{k}^2 + (1-x)^2 m^2 + x\lambda^2$$

$$\vec{k}' = \vec{k} - (1-x)\vec{q}$$

The first term comes from the wave - function renormalisation diagrams or the Z₂ sitting out in front of $U^+(\infty)|P_0\rangle$. We may

write $Z_2 = \frac{1}{1 - B(2)}$ to second order in g.

We can verify that the value L(2) of the second order term (from the proper vertex diagram (c)) at $q^2 = 0$ equals -B(2), as required by the Ward identity and thus

$$F(q^2) = 1$$

The above result for $F(q^2)$ of course can equally well be derived from the Feynman rules. The variable x is associated there with the parameters used to combine the k^2 and λ^2 denominators.

More generally we may write the vertex at $q^2 = 0$ in the form

$$I = \sum_{a=1}^n \lambda_a \int d^2k \int_0^1 dx f_a(\vec{k}^2, x)$$

$$\equiv \sum_{a=1}^n \lambda_a \int_0^1 dx f_a(x)$$

where the sum is over the charged fields (partons of charge e λ_a) of the theory. The function $f_a(x)$ is the fractional longitudinal momentum distribution of parton a in the nucleon as viewed from an infinite momentum reference frame. The definition is clearly extendable to any order in perturbation theory. To order g² in the above theory

$$f(x) = \frac{1}{1 - B(2)} \delta(1-x) + \frac{1}{2} \frac{g^2}{(2\pi)^3} \int d^2k \frac{x(1-x)}{D^2(k^2)}$$

and to higher order f is obtained from the graph

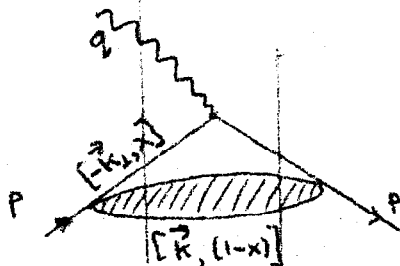

leaving the x-integration undone. Wave function normalisation contributions also need to be considered here.

In Drell and Yan's work, the renormalised nucleon Born term is assumed to disappear in the final physical result by the choice $Z_2 = 0$. This is the usual statement in field theory for a composite nucleon. With this choice $F(q^2)$ falls rapidly in Q^2 in each order in perturbation theory*, and is normalised to 1 at $Q^2 = 0$. In the following we shall keep the Born term contribution, since it doesn't complicate the results.

We should emphasise here that the results in terms of $f(x)$ discussed here are general and not specific to the spin 0 theory.

Let us turn next to the calculation of the virtual forward compton amplitude $T_{\mu\nu}(q^2, \nu)$ to order q^2 in perturbation theory.

Again, we use spin zero electrodynamics to simplify the calculations, as well as the infinite momentum device. The surviving $P \rightarrow \infty$ time-ordered diagrams are

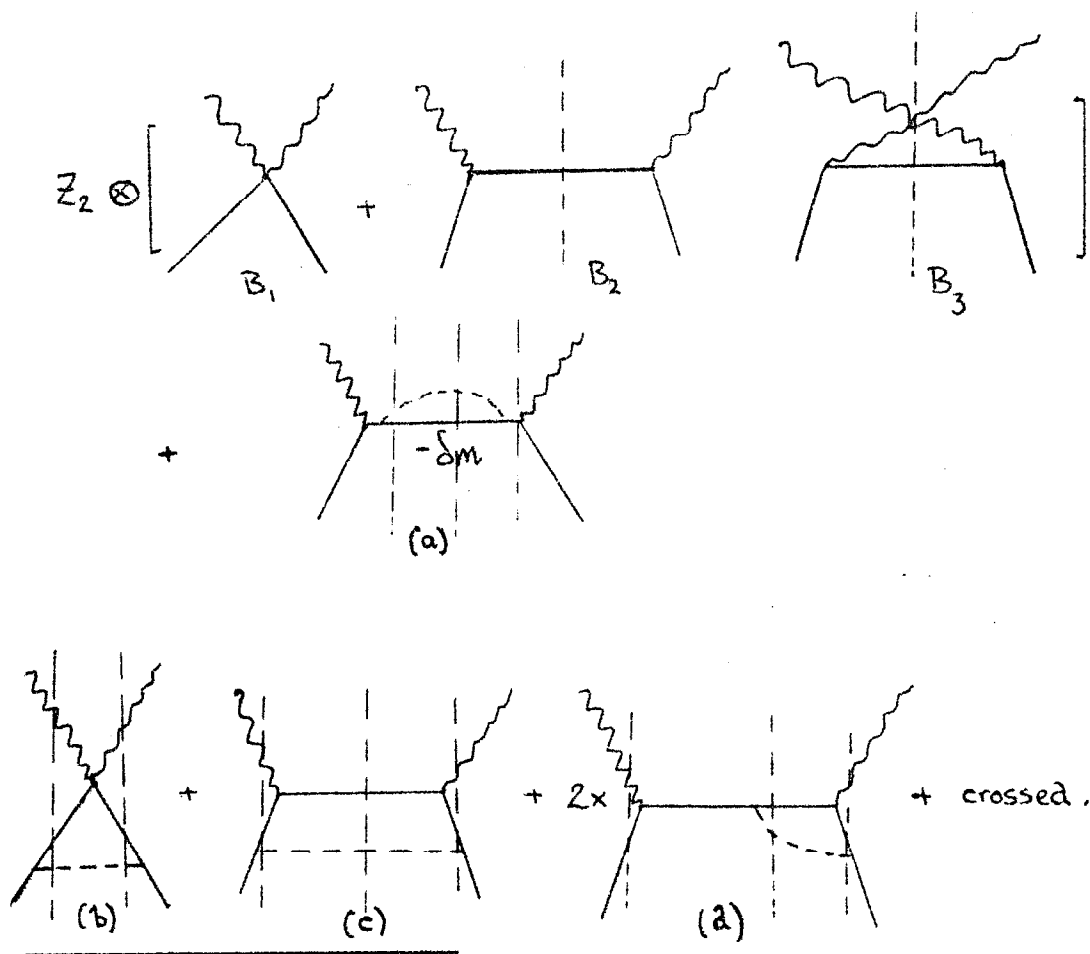

* In contrast, the entire series including the Born term exponentiates to a decreasing form factor in soft-photon - exponentiated QED.

Using the decomposition of the covariant and G. I. tensor

$$T_{\mu\nu} = - \left(g_{\mu\nu} - \frac{q_\mu q_\nu}{q^2} \right) T_1(q^2, \nu) + \frac{1}{m^2} \left(P_\mu - \frac{P \cdot q q_\mu}{q^2} \right) \left(P_\nu - \frac{P \cdot q q_\nu}{q^2} \right) T_2(q^2, \nu)$$

we see that $T_{00} \rightarrow \frac{1}{M^2} P^2 T_2$ and $T_{ii} \rightarrow T_1$

where i is chosen orthogonal to the \hat{q} direction.

Diagrams B2, B3, (a), (c) and (d) contribute to T_2 :

$$\begin{aligned} T_2(q^2, \nu) &= \frac{1}{1-B_{(2)}} \left[\frac{4m^2}{2m\nu - \vec{q}_\perp^2} \right] \\ &+ \frac{g^2}{16\pi^3} \int d^2k \int_0^1 dx \frac{4m^2}{x(1-x)} \left[\frac{1}{(2m\nu - \vec{q}_\perp^2)^2} \left(\frac{1}{A'} - \frac{1}{A} \right) \right. \\ &\quad \left. + \frac{2}{2m\nu - \vec{q}_\perp^2} \cdot \frac{1}{A'} \cdot \frac{1}{A} + \frac{1}{A'} \cdot \frac{1}{A^2} \right] + (\nu \rightarrow -\nu). \\ &= \frac{4m^2}{2m\nu - \vec{q}_\perp^2} \left[\frac{1}{1-B_{(2)}} + \frac{g^2}{16\pi^3} \int d^2k \int_0^1 dx \frac{x(1-x)}{D} \left(\frac{2}{D} - \frac{1}{\tilde{D}} \right) \right] \\ &- \frac{g^2}{16\pi^3} \int d^2k \int_0^1 dx \frac{x^2(1-x)^2 4m^2}{\tilde{D} + x(1-x)(\vec{q}_\perp^2 - 2m\nu)} \left[\frac{1}{D} - \frac{1}{\tilde{D}} \right]^2 \\ &\quad + (\nu \rightarrow -\nu). \end{aligned}$$

The definitions of A , A' , $D = D(k^2)$, $\tilde{D} = D(\tilde{k}^2)$ have been given before.

We can check that this agrees with the usual Feynman result and has the correct threshold results, etc. In particular,

$$\lim_{q^2 \rightarrow 0} \sum_{\nu} T_2(q^2, \nu) = \lim_{q^2 \rightarrow 0} \sum_{\nu} T_2^{\text{Born}} \quad \text{We will return to the } T_1$$

amplitude below.

Let us now consider the crucial limiting region of large $|q^2|$ and large ν . Fortunately the \tilde{k}_1^2 and x integrals here are sufficiently convergent such that the limit is straightforward. For

$$2m\nu \gg \frac{\langle k^2 \rangle}{\langle x \rangle}, \quad \vec{q}^2 \gg \langle \tilde{k}_1^2 \rangle, \quad \text{we may take}$$

$$A' \rightarrow 2m\nu - \frac{\vec{q}^2}{x} + i\epsilon.$$

and

$$T_2(\nu, q^2) \rightarrow \frac{1}{1-B(z)} \cdot \frac{4m^2}{2m\nu - \vec{q}^2} + \frac{g^2}{16\pi^3} \int d^2k \int_0^1 \frac{dx}{x(1-x)} \cdot \frac{4m^2}{A^2(2m\nu - \frac{\vec{q}^2}{x} + i\epsilon)} \quad + (\nu \rightarrow -\nu)$$

$$\nu W_2(\nu, q^2) = \frac{1}{\pi 2m} \text{Im } T_2(\nu, q^2) \nu$$

$$= \sum_a \lambda_a^2 \int_0^1 dx f_a(x) x \delta(x - \frac{1}{\omega}) \equiv F_2(\omega)$$

where $\omega \equiv 2m\nu/Q^2$. We used here

$$\text{Im} \frac{1}{2m\nu - \frac{\vec{q}^2}{x} + i\epsilon} = \pi \frac{x}{2m\nu} \delta(x - \frac{\vec{q}^2}{2m\nu}).$$

This result is clearly much more general than 2nd order perturbation theory, the crucial step being whether the \vec{k}^2 and x integrals are sufficiently convergent to allow the limiting form of the A' propagator. Generally we need to replace the imaginary part of the intermediate propagator in

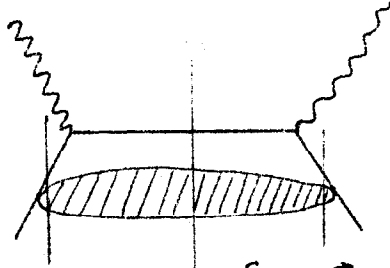

by the δ -fn. contribution $\pi \frac{x}{2m\nu} \delta(x - \vec{q}^2/2m\nu)$
 We ignore in the same spirit vertex corrections:



which have a form factor fall off in q^2

Further Drell and Yan (See paper II) have shown in fourth order perturbation theory that the renormalization factor from

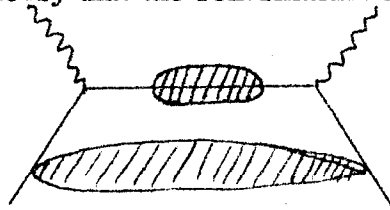

hadronic corrections to the top "parton" line cancel when all time orderings are considered and the $Q^2, 2m\nu$ large limit is taken. The resulting scaling form for $\nu W_2 = F_2(\omega)$

is thus the realization of the Bjorken limit based on impulse approximation in field theory.

In the case of pseudo-scalar γ^5 spin $\frac{1}{2}$ theory or γ_μ vector electrodynamics*, the limit $A' \rightarrow \frac{2m\nu}{x} - \vec{q}_\perp^2$

is not justified since the numerator factors make the resulting residual integration divergent at high k^2 . In Drell and Yan's work an ad hoc transverse-momentum cutoff characteristic of hadronic vertices is used to ensure the limit. Generally a super-renormalizable theory is required to ensure the existence of the scaling limit. Note, however, that the contribution

* The calculations are slightly complicated by the Z -graph contributions.

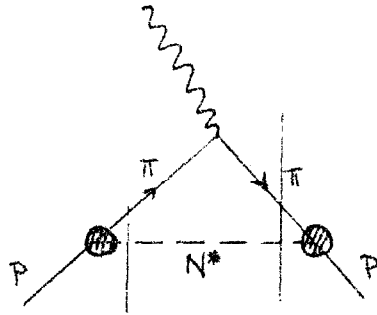

to the proton vertex automatically is convergent because of the form factors at the π -p- N^* vertex, which, in fact, yield (probably exponential) covariant cutoffs at large k^2 or small x . A complete analysis of the structure function $f_2(x)$ in terms of forward on-shell parton-proton scattering (from u-channel exchange contributions) will be presented by F. Close, J. Gunion and myself (to be published).

We can also note here the remarkable connection between the structure function and the elastic form factor noted by Drell and Yan. Recall that to order g^2 [We drop the pole term]

$$F(q^2) \propto \int_0^1 dx \int d^2k \frac{x(1-x)}{D(\vec{k}^2)D(\vec{k}^2)}$$

$$\vec{k} \sim \vec{k} - (1-x)\vec{q}$$

more generally the graph shown gives an integrand of the form

$$\frac{N(x, 1-x)}{D(\vec{k}^2, x)D(\vec{k}^2, x)}$$

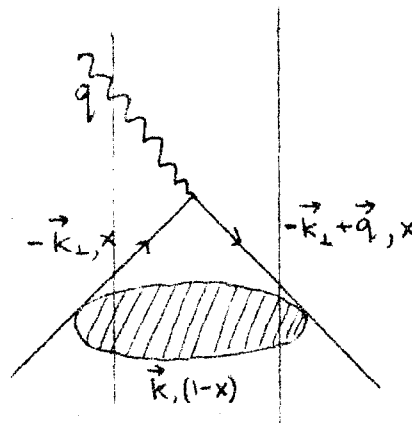

The asymptotic form of $F(q^2)$ for large Q^2 is clearly controlled by the behaviour of the integrand near $x \sim 1$. In this region we can take the integrand in x to be of the form

$$\frac{(1-x)^p}{[C + (1-x)^2 \vec{q}^2]^n} \quad (x \sim 1, \vec{q}^2 \rightarrow \infty)$$

changing variables to $y = (1-x) |\vec{q}|$ shows

$$F(q^2) \sim \int_0^1 dy \frac{y^p}{[c+y^2]^n} \frac{1}{|q|^p}$$

Thus if $F(q^2) \sim \left(\frac{1}{Q^2}\right)^{\frac{p+1}{2}}$ for $Q^2 \rightarrow \infty$, then

$$f(x) \sim (1-x)^p \text{ at } x \sim 1.$$

and

$$\nu W_2(\omega) = \frac{1}{\omega} f\left(\frac{1}{\omega}\right) \sim \frac{1}{\omega} \left(1 - \frac{1}{\omega}\right)^p \text{ for } \omega \sim 1.$$

This is the Drell-Yan result; the data seems to be consistent with $p = 3$, but there are still ambiguities.

A caution involved in this comparison is that

$$F(q^2) = \sum_{a=1}^n \lambda_a F_a(q^2)$$

is linear in the charge λ_a whereas νW_2 is quadratic. In fact, if the parton^(a)-proton scattering indicated in the figure below

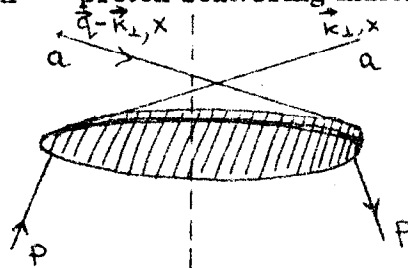

is symmetric for parton and anti-parton (as in the case of the pomeron - or zero quantum exchange contributions) then such contributions contribute to νW_2 but cancel for $F(q^2)$. Clearly the Drell-Yan relationship refers to the non-diffractive, etc. component of $\nu W_2(\omega)$.

Next, let us return to the T_1 amplitude. Again to second order in the spin 0 electrodynamics calculation, we find contributions to T_{ii} from figures 9-B1, (b), (c), and obtain $(\hat{i} \perp \hat{q})$

$$T_1(\nu, q^2) = 2 \left\{ \frac{1}{1-B_{(2)}} + \frac{g^2}{16\pi^3} \int d^2k \int_0^1 \frac{dx}{x^2(1-x)} \left[\frac{1}{A^2} + \frac{2\vec{k}_\perp^2}{x A^2} \left(\frac{1}{A_+} + \frac{1}{A_-} \right) \right] \right\}$$

$$= 2 \left\{ \frac{1}{1-B_{(2)}} + \frac{g^2}{16\pi^3} \int d^2k \int_0^1 dx (1-x) \left[\frac{1}{D^2} - \sum_{\pm\nu} \frac{2k_\perp^2}{D^2} \frac{(1-x)}{D + x(1-x)(\vec{q}_\perp^2 - 2m\nu)} \right] \right\}$$

for $q^2 = Q^2 = 0$, the last term is

$$\sum_{\pm\nu} \frac{\vec{k}_\perp^2}{D^2} \frac{(1-x)}{D - x(1-x)2m\nu}$$

and for $\nu \rightarrow 0$ it becomes (by integration by parts on $d\vec{k}_\perp^2$)*

$$\frac{2\vec{k}_\perp^2}{D^2} (1-x) = (1-x)/D^2$$

Thus

$$\lim_{\nu \rightarrow 0} T_1(\nu, 0) = 2 \left[\frac{1}{1-B_{(2)}} + L_{(2)} \right] = ? = T_{\text{BORN}},$$

- which is the Thomson limit in field theory. On the other hand at large energies

$$\lim_{\nu \rightarrow \infty} T_1(\nu, q^2) = 2 \left[\frac{1}{1-B_{(2)}} + \frac{g^2}{16\pi^3} \int d^2k \int_0^1 dx \frac{(1-x)}{D^2} \right] = T_1^{\text{Born}} * \int_0^1 \frac{f(x)}{x} dx$$

* Notice that a sharp cutoff in the \vec{k}_\perp^2 integration at k_{max}^2 would introduce a surface term and violate the Thomson limit. Generally, we can adopt covariant regularization procedures which will effect the convergence required in the Drell-Yan procedure.

This is a new result obtained by Close, J. Gunion and myself (to be published) which asserts that at high energies the (coherent) impulse approximation in field theory yields a constant "fixed pole" in forward Compton scattering. Its value is independent of photon mass q^2 and has the same relationship to the Born theory as in nuclear physics:

$$\left(\nu \gg \text{B.E.} \right) \frac{T_1^A(\nu)}{T_1^A(\nu=0)} = \frac{Ze^2/m_p}{(Ze)^2/m_a} \quad \text{nucleus}$$

$$\left(\nu \gg \frac{\langle \vec{k}^2 \rangle}{\langle x \rangle} \right) \frac{T_1(\nu, Q^2)}{T_1(\nu=0, Q)} = \frac{\sum \lambda_a^2 e^2 \frac{1}{m_p} \langle \frac{1}{x} \rangle}{e^2 \frac{1}{m_p}} \quad \text{nucleon.}$$

The expectation value $\langle \frac{1}{x m_p} \rangle$ is effectively $\langle \frac{1}{m_a} \rangle$ the inverse mass of the parton. The result also holds in spin $\frac{1}{2}$ electrodynamics; here the dominant graph is

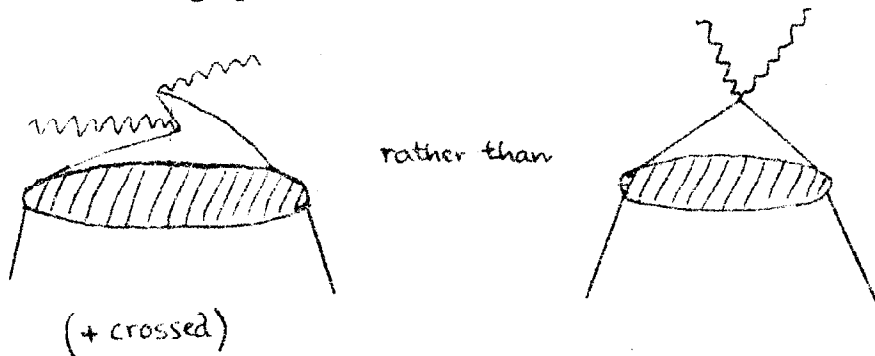

In each case we obtain a contribution similar to $F(q^2)$ with $\sum \lambda_a^2 \frac{1}{x}$ instead of $\sum \lambda_a$. It has been found, however (in models) that the above result for the fixed poles does not receive contributions from amplitudes with symmetric $m_{\bar{a}p} = m_{ap}$ forward scattering amplitudes. Thus the integral $\int f(x) x^{-1} dx$ does not receive contributions from the diffractive component of $\nu W_2(\omega)$

$= F_2(\omega)$

and is expected to converge at $x \sim 0$. This is clearly true for the model N^* "u-channel" exchange contributions to $f(x)$ which as discussed above, give very rapid falloff at $x \sim 0$. [Of course the Thomson amplitude is finite at all energies; whether or not the constant limit emerges - underneath the Regge exchange contributions which give the $\nu^{\frac{1}{2}}$ leading behaviour in $T_1(\nu, 0)$ - depends on the convergence of the residual integration]. The experimental existence of the fixed pole for the proton and neutron would seem to be an essential consequence of the local nature of the 2 photon interaction at high energies.

Other Applications:

An immediate result of the parton-model is the sum rule of Gottfried and Drell, Levy, and Yan :

$$\int_0^1 \frac{d\omega}{\omega} \nu W_2(\omega) = \int_0^1 \frac{dx}{x} F_2\left(\frac{1}{x}\right) = \sum_a \lambda_a^2 \int_0^1 dx f_a(x)$$

For integer charged partons, this is greater or equal to 1 since

$$1 = \sum_a \lambda_a \int_0^1 f_a(x) dx$$

- but this is easily satisfied for present data since νW_2 appears to be approximately constant at large ω . *

It must be admitted here that the field-theoretic formalism does not naturally incorporate fractionally-charged partons (quarks), since the charged particle emerges (after redressing its self-field) roughly along the direction of \vec{q} , without interacting with the other constituents. The treatment of heavy mass quarks as free constituents would also seem to be completely heuristic.

Nevertheless, allowing for fractional charge, we obtain the parton result of Bjorken and Paschos:

$$\nu W_2 = \frac{1}{\omega} \sum_N P_N \sum_{i=1}^N \lambda_i^2 f_i^N\left(\frac{1}{\omega}\right)$$

$$\sum_N P_N \int_0^1 f_N^i(x) dx = 1$$

* However, it has been argued [Polkinghorne, Landshoff and others] that the diffractive component of the data for νW_2 should be excluded from the sum rule.

where P_N is the probability to have N parton constituents of charge λ_i . Generally $\nu W_2 \rightarrow 0$ as $\omega \rightarrow \infty$ unless as $\omega \rightarrow \infty$ the \sum_N increases proportionately. If the proton's momentum is distributed equally among the charged partons, then on average

$$\int_0^1 x f_N(x) dx = \frac{1}{N}$$

Thus

$$\int \nu W_2 d\left(\frac{1}{\omega}\right) = \sum_N P_N \frac{\sum_{i=1}^N \lambda_i^2}{N}$$

$$= \text{mean square charge/parton} = \left(\frac{2}{9} \text{ in quark model}\right)$$

Experimentally, the left-hand side is $\approx .18$ for the proton. This is consistent with a model of quarks and neutral particles, but is not particularly definitive.

For the case of spin $\frac{1}{2}$ partons, one finds [Drell and Yan, Bjorken and Paschos]

$$F_1(\omega) = \omega F_2(\omega), \quad \text{ie} \quad G_L \rightarrow 0.$$

and for spin - 0 partons

$$F_1(\omega) = 0 \quad \text{ie} \quad G_T \rightarrow 0.$$

The data favours the spin $\frac{1}{2}$ case, but again the results are not definitive.

There is, however, a complete range of similar predictions of the parton model for inel. e-neutron scattering, inel. ν - proton scattering, and e+e- annihilation. A survey of these tests has been given by H. Llewellyn Smith in 1970. [Th 1188 - CERN]. In addition, Bjorken and Paschos have discussed a parton-model application to inelastic compton scattering

$$\gamma + p \rightarrow \gamma + all \quad \text{at large } \nu \text{ and large } t = Q^2 \text{ and have}$$

obtained scaling cross-sections proportional to inelastic e-p scattering. P. Roy and I have shown, however, that from the field theoretic point of view the impulse approximation is not generally met for this process, [Phys. Rev. 1971]. R. Jaffee (to be published) has shown that the process

$$\gamma + p \rightarrow \mu^+ + \mu^- + all$$

does have a parton interpretation for large invariant pair masses.

Another very important application of the parton model has been discussed by Dreil and Yan, [Ann. Phys. (1971)]

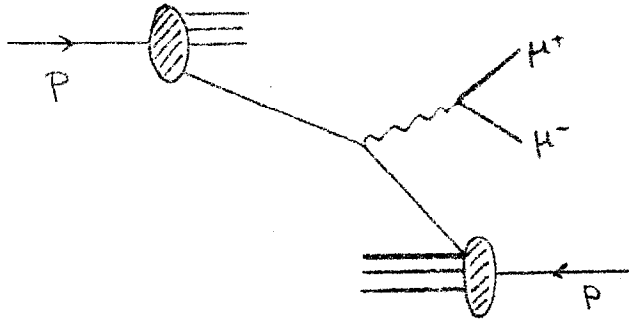

The process $p + p \rightarrow \mu^+ + \mu^- + \dots$ all may be calculated in terms of parton-antiparton annihilation and thus involves the convolution of longitudinal momentum distributions of partons and antipartons in the proton. The Jaffe process discussed above similarly invokes the distribution function of photon. The latter can also be studied by the process, inelastic electron-photon scattering discussed by T. Kinoshita, H. Terazawa and myself [see P.R.L., 1971], and T. Walsh. (to be published).

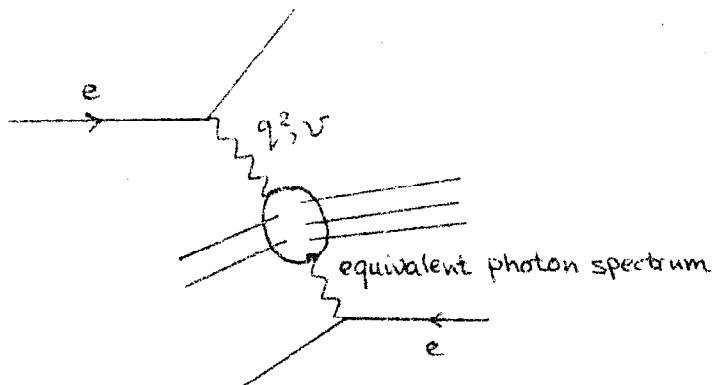

Hopefully, all of these processes will lead the way to an understanding of the fundamental electromagnetic structure of the hadrons.

Acknowledgment

The author is grateful to Mrs. Audrey Irvine and Mr. Peter L. Knight for their arduous editorial assistance.

REFERENCES FOR CHAPTERS I - IV.

- Abarbanel, H.D.I., and M.L. Goldberger (1968), Phys. Rev. 165, 1594.
- Aldins, J., S. Brodsky, A.J. Dufner, and T.K. Kinoshita (1969), ~~to be~~
published, Phys. Rev. Letters 23, 441 and Phys. Rev. (to be published).
- Arnowitz, R. (1953), Phys. Rev. 92, 1002.
- Asbury, J. et al. (1967), Phys. Rev. Letters 21, 1501 and references therein.
- Bailey, J., W. Bartl, G. von Bochmann, R.C.A. Brown, F.J.H. Farley, H. Jöstlein, E. Ficasso, and R.W. Williams (1969), Phys. Letters 28B, 287.
- Baranger, M., H.A. Bethe, and R.P. Feynman (1952), Phys. Rev. 92, 482.
- Baranger, M., F. Dyson, and F. Salpeter (1952), Phys. Rev. 88, 680.
- Barber, W.C., B. Gittelman, G.K. O'Neill, and B. Richter (1966), Phys. Rev. Letters 16, 1127.
- Barber, W.C. et al. (1960), Report to the 14th International Conference on High-Energy Physics, Vienna.
- Barker, W.A., and F.N. Glover (1955), Phys. Rev. 99, 317.
- Barrett, R.C., S.J. Brodsky, G.W. Erickson, and M.H. Goldhaber (1968), Phys. Rev. 166, 1587. See also Brodsky and de Rafael (1968).
- Bell, J.S., and E. de Rafael (1969), CERN Preprint TH-1019, to be published.
- Bernstein, J., and T.D. Lee (1963), Phys. Rev. Letters 11, 512.
- Bethe, H.A. (1947), Phys. Rev. 72, 339.
- Bethe, H.A., L.M. Brown,^{and} J.R. Stehn (1950), Phys. Rev. 77, 370.

- Bethe, H.A., and E.E. Salpeter (1957), Quantum Mechanics of One-¹ and Two-~~Two~~ Electron Atoms (Academic Press, Inc., New York).
- Bjorken, J.D. (1966), Phys. Rev. 148, 1467; 160, 1582.
- Bjorken, J.D., and S.D. Drell (1964), Relativistic Quantum Mechanics (McGraw-Hill, New York).
- Bohr, A. (1948), Phys. Rev. 73, 1109.
- Breit, G. (1929), Phys. Rev. 34, 553.
- Breit, G., and R.E. Meyerott (1947), Phys. Rev. 72, 1023.
- Brodsky, S.J., and E. de Rafael (1968), Phys. Rev. 168, 1620.
- Brodsky, S.J., and G.W. Erickson (1966), Phys. Rev. 146, 26.
- Brodsky, S.J., and R.G. Parsons (1967), Phys. Rev. 163, 134.
- Brodsky, S.J., and J. Primack (1969), Ann. Phys. (N.Y.) 52, 315, and Phys. Rev. 174, 2071 (1968).
- Brodsky, S.J., and J.D. Sullivan (1967), Phys. Rev. 156, 1644.
- Burnett, T., and M.J. Levine (1967), Phys. Letters 24B, 467.
- Crampton, S.B., D. Kleppner,^{and} N.P. Ramsey (1963), Phys. Rev. Letters 11, 338.
Crane, P. et al. (1967), Phys. Rev. Letters 22, 163.
- Dayhof, E.S., S. Triebwasser, and W.E. Lamb, Jr. (1953), Phys. Rev. 89, 106.
- Di Giacomo, A. (1969), Nucl. Phys. B11, 411.
- Drell, S.D., and A.C. Hearn (1966), Phys. Rev. Letters 16, 908.
- Drell, S.D., and H.R. Pagels (1965), Phys. Rev. 140, 3397.
- Drell, S.D., and J.D. Sullivan (1967), Phys. Rev. 154, 1477.
- Elend, M.H. (1966), Phys. Letters 20, 682; erratum, ibid. 21, 720.
- See also H. Suura and E.H. Wickman, Phys. Rev. 105, 1930 (1957);
 and A. Petermann, ibid. 105, 1931 (1957) and Fortschr., Physik 6
 505 (1958).
- Engfer, J.L. (1969), Nucl. Phys. A
- Erickson, G.W., and D.R. Yennie (1965), Ann. Phys. (N.Y.) 35, 271; 35, 447.

- Erickson, G. W. (1962), Thesis, University of Minnesota (unpublished).
- Erickson, G.W. (1968), Invited Paper at the International Symposium on the "Physics of One-^l and Two-Electron Atoms^l" Munich.
- Farley, F.J.M. (1969), Invited Paper at the First Meeting of the European Physical Society at Florence.
- Feinberg, G. (1968) in Atomic Physics, Proceedings of the First International Conference on Atomic Physics (Plenum Press, New York).
- Fermi, E. (1930), Z. Physik 60, 320.
- Feynman, R.P. (1949), Phys. Rev. 76, 749; 76, 769.
- Feynman, R.P. (1950), Phys. Rev. 80, 440.
- Fried, H.M., and D.R. Yennie (1960), Phys. Rev. Letters 4, 583.
- Fronsdal, C. (1969), Phys. Rev. 179, 1513.
- Fulton, T., and P.C. Martin (1954), Phys. Rev. 95, 811.
- Gell-Mann, M., and M.L. Goldberger (1954), Phys. Rev. 96, 1433.
- Gell-Mann, M., M.L. Goldberger, N. Kroll, and F. Low (1969), Phys. Rev. 179, 1518.
- Gell-Mann, M., and F. Low (1951), Phys. Rev. 84, 350.
- Gerasimov, S.B. (1965), Yad. Fiz. 2, 598 [Sov. J. Nucl. Phys. 2, 430 (1966)].
- Goldhaber, A., and N. Nieto (1968), Phys. Rev. Letters 21, 567.
- Gourdin, M., and E. de Rafael (1969), Nucl. Phys. B10, 667.
- Grotch, H., and D.R. Yennie (1969), Rev. Mod. Phys. 41, 350.
- Guerin, F. (1967), Nuovo Cimento 50A, 1, 211.
- Harriman, J.K. (1956), Phys. Rev. 101, 594.
- Hayes, S. et al. (1969), Phys. Rev. Letters 21, 1501.
- Hearn, A.C. (1969), Stanford University Report ITF-247, Documentation on REDUCE is available from the Computation Center, Stanford University, Stanford, California 94305.

- Hosoda, M., and K. Yamamoto (1965), Progr. Theoret. Phys. (Kyoto) 30, 426.
- Hughes, V.W. (1967), Phys. Today, December 1967, p.29.
- Hughes, V.W. (1969), in Atomic Physics, Proceedings of the First International Conference on Atomic Physics (Plenum Press, New York).
- Iddings, C.K. (1965), Phys. Rev. 138, 8446.
- Iddings, C.K., and P.M. Platzman (1959), Phys. Rev. 113, 192; 115, 919.
- Karplus, R., A. Klein, and J. Schwinger (1951), Phys. Rev. 84, 597.
- Karplus, R., and A. Klein (1952), Phys. Rev. 87, 848.
- Karplus, R., A. Klein, and J. Schwinger (1952), Phys. Rev. 86, 288.
- Kaufman, S., W. E. Lamb, K. Lee, and M. Leventhal (1969), Phys. Rev. Letters 22, 507.
- Kleppner, D. (1969), Brandeis Summer Institute, 1969 (Gordon and Breach, New York, 1970), Vol. 1.
- Kinoshita, T. (1962), J. Math. Phys. 3, 650.
- Kinoshita, T. (1967), Nuovo Cimento 51B, 140.
- Kroll, N., and F. Pollock (1951), Phys. Rev. 84, 594; 86, 876.
- Lamb, W.E., Jr. (1952), Phys. Rev. 85, 259.
- Lamb, W.E., Jr., and R.C. Retherford (1952), Phys. Rev. 86, 1014.
- Lapidus, L.I., and Chou Kuang-Chao (1960), Zh. Eksp. Teor. Fiz. 39, 1286
[Sov. Phys. JETP 12, 898 (1961)].
- Lapidus, L.I., and Chou Kuang-Chao (1961), Zh. Eksp. Teor. Fiz. 41, 1546
[Sov. Phys. JETP 14, 1102 (1962)].
- Lautrup, B.E., and E. de Rafael (1968), Phys. Rev. 174, 1835.
- Layzer, A.J. (1960), Phys. Rev. Letters 4, 580 and J. Math. Phys. 2, 292, 308 (1961).

- Layzer, A.J. (1961), Bull. Am. Phys. Soc. 6, 514; Nuovo Cimento 33, 1538 (1964).
- Lee, T.D., and C.N. Yang (1962), Phys. Rev. 128, 885.
- Lee, T.D. (1962), Phys. Rev. 128, 899.
- Lieb, F. (1955), Phil. Mag. 46, 311.
- Low, F. (1950), Phys. Rev. 77, 361.
- Low, F. (1952), Phys. Rev. 88, 53.
- Low, F. (1954), Phys. Rev. 96, 1428.
- Lurie, D. (1968), Particles and Fields (Interscience Publishers, New York).
- Mandelstam, S. (1955), Proc. Roy. Soc. (London), A233, 248.
- McGee, Ian J. (1967), Phys. Rev. 158, 1500.
- Meister, N., and D.R. Yennie (1963), Phys. Rev. 130, 1210.
- Metcalf, H., W. Brandenberger, and J.C. Baird (1968), Phys. Rev. Letters 21, 165.
- Mignaco, J.A., and E. Remiddi (1968), CERN preprint TH-953.
- Mills, R.L., and N.M. Kroll (1954), Phys. Rev. 98, 1489.
- Nakanishi, N. (1961), Progr. Theoret. Phys. Supplement 18, 1.
- Newcomb, W.A., and E.E. Salpeter (1955), Phys. Rev. 97, 1146.
- Osborn, H. (1960), Phys. Rev. 176, 1523.
- Parker, W.H. et al. (1967), Phys. Rev. Letters 18, 287. See also D.N. Langenberg et al., Proceedings of the Third International Conference on Atomic Masses, edited by R.C. Barber (University of Manitoba Press, Winnipeg, 1968), p.439.
- Parsons, R.G. (1968), Phys. Rev. 168, 1562.
- Periot, E.D., Jr., R.H. Beers, and V.W. Hughes (1967), Phys. Rev. Letters 18, 767.

- Petermann, H. (1957), Helv. Phys. Acta 30, 407; Nucl. Phys. 5, 677 (1958).
- Pustovalov, G.E. (1957), Sov. Phys. $\frac{1}{M}$ JETP 5, 1234.
- Rich, A. (1968), Phys. Rev. Letters 20, 967.
- Robiscoe, R. (1968), Phys. Rev. 168, 4; see also Phys. Rev. 138, A22 (1964),
- Ruderman, M.A. (1966), Phys. Rev. Letters 17, 794. Phys. Rev. Letters 24, 559 (1970)
- Sakurai, J.J. (1967), Advanced Quantum Mechanics (Addison-Wesley, Reading, Massachusetts).
- Salpeter, E.E., and H.A. Bethe (1951), Phys. Rev. 84, 1232.
- Salpeter, E.E. (1952), Phys. Rev. 87, 328.
- Schwartz, C. (1969), in Atomic Physics, Proceedings of the First International Conference on Atomic Physics (Plenum Press, New York).
- Schwartz, C., and J.J. Tiemann (1959), Ann. Phys. (N.Y.) 6, 178.
- Schwinger, J. (1949), Phys. Rev. 73, 416; 76, 790.
- Schwinger, J. (1951), Proc. Natl. Acad. Sci. U.S. 37, 452.
- Schwinger, J. (1958), Quantum Electrodynamics (Dover Publications, Inc., New York).
- Serber, R. (1935), Phys. Rev. 48, 49.
- Shaffer, R.A. (1964), Phys. Rev. 135, B187.
- Shyn, T.W., W. L. Williams, R.T. Robiscoe, and T. Rebane (1969), Phys. Rev. Letters 22, 1273.
- Siemann, R.H. et al. (1969), Phys. Rev. Letters 22, 421.
- Smith, C.H. Llewellyn (1968), CERN preprint TH-946.
- Sommerfield, C.M. (1957), Phys. Rev. 107, 328; Ann. Phys. (N.Y.) 5, 26 (1958).
- Soto, M.F., Jr. (1966), Phys. Rev. Letters 17, 1153 (1966).
- Sternheim, M.E. (1965), Phys. Rev. 138, 3130.

- Taylor, B.N., W.H. Parker, D.N. Langenberg (1969), Rev. Mod. Phys., to be published.
- Telegdi, V. (1969), in Atomic Physics, Proceedings of the First International Conference on Atomic Physics (Plenum Press, New York).
- Trower, P. (1969), private communication.
- Uehling, E.A. (1935), Phys. Rev. 48, 55.
- Vessot, R. et al. (1966), IEEE Trans. Instr. Meas. IM-15, 165.
- Verganelakis, A., and D. Zwanziger (1965), Nuovo Cimento 39, 613.
- Vorburger, T. V., and B. L. Cosens (1969), ~~to be published~~ Phys. Rev. Letters 23, 1275.
- Weisskopf, V.F. (1939), Phys. Rev. 56, 72.
- Welton, T.A. (1948), Phys. Rev. 74, 1157.
- Weneser, J., R. Bersohn, and N.M. Kroll (1953), Phys. Rev. 91, 1157.
- Wichman,ⁿ F.H., and N.M. Kroll (1956), Phys. Rev. 101, 843.
- Wilkinson, D.T., and H.R. Crane (1963), Phys. Rev. 130, 852.
- Yennie, D.R. (1964)³, Lectures on Strong and Electromagnetic Interactions Brandeis Summer Institute, 1963, Vol. 1 (Notes by S. Brodsky).
- Yennie, D.R. and G.W. Erickson (1965), Ann. Phys. (N.Y.) 35, 271, 447.
- Yennie, D.R., S. Frautshi, and H. Suura (1961), Ann. Phys. (N.Y.) 13, 379.
- Yennie, D.R. (1967), Proceedings of the International Symposium on Electron and Photon Interactions at High Energies, Stanford.
- Zemach, A.C. (1956), Phys. Rev. 104, 1771.
- Zwanziger, D.W. (1961), Bull. Am. Phys. Soc. 6, 514; Nuovo Cimento 34, 77 (1964);
- Zwanziger, D.W. (1960), Phys. Rev. 121, 1128.