

# HS-134 Carbon Monoxide sensor element

## 1. Characteristics

1. 1. High sensitive and good selectivity to low carbon monoxide concentration.
1. 2 .Long life and reliable stability.

## 2. Structure, configuration, symbol of components.

2. 1. Structure and configuration of HS-134 is shown as Fig. 1, sensitive components composed by micro  $Al_2O_3$  ceramic tube, Tin Dioxide ( $SnO_2$ ) sensitive layer, active carbon filtering layer include and made by plastic and stainless steel net.
- 2.2. Active carbon Particle reduces interference from gases of  $NO_x$  , Alkane, etc.
- 2.3 The enveloped HS-134 gas sensitive components have 6 pin, 4 of them are

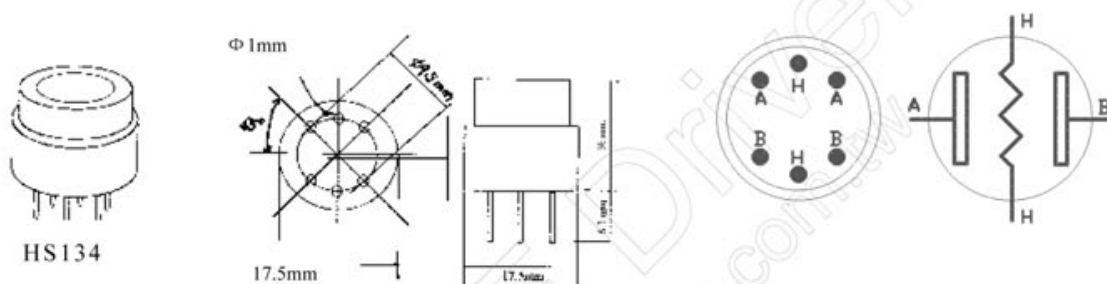

used to take signals(A, B) , and other 2 (H) are used for providing heating current.

## 3. Working Principle

### A. Standard circuit

As shown in Fig 2, standard measuring circuit of HS-134 include 2 parts. one is heating circuit. Have time control function (the high voltage and the low voltage work circularly.) The second is the signal output circuit, it can accurately respond changes of surface resistance of the sensor.

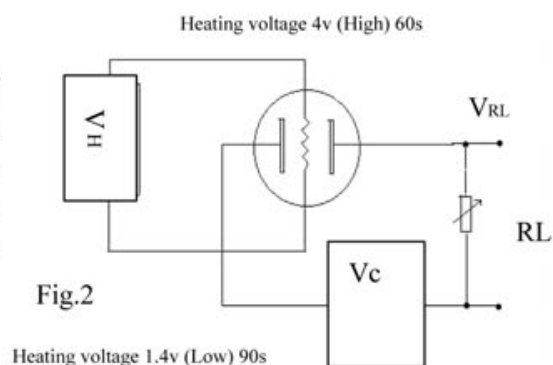

- b. The surface resistance of the sensor  $R_s$  is obtained through effected voltage signal output of the load resistance  $R_L$  which series-wound. The relationship between them as below:

$$R_s \backslash R_L = (V_c - V_{RL}) / V_{RL}$$

Fig. 3 is relative curve between output signal VRL(measured by using Fig.2 circuit and CO gas concentration.

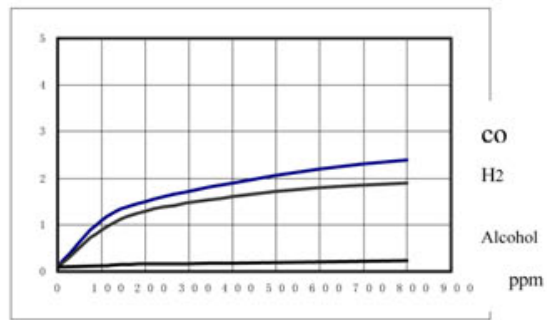

Fig.3

#### 4. Figure

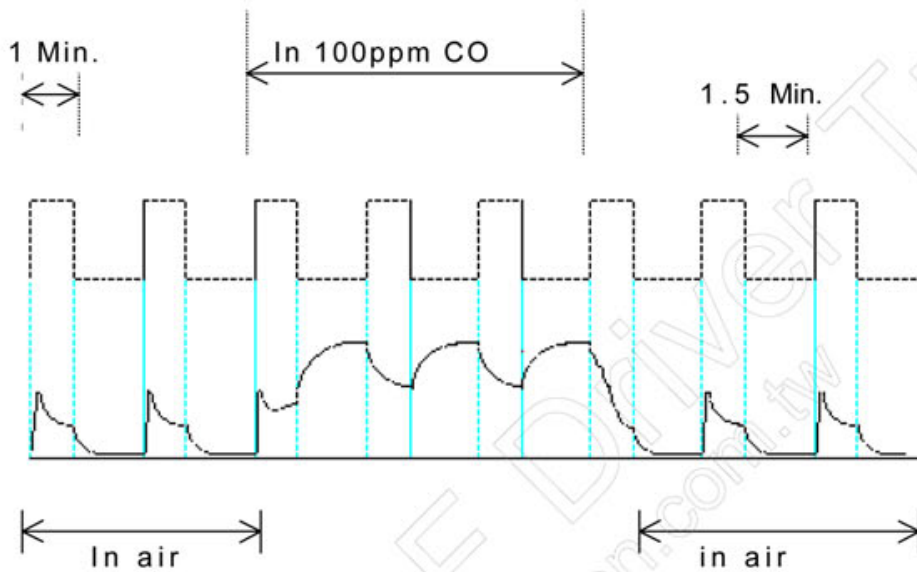

Fig. 4

Base on Fig. 2 circuit, Fig. 4 is the signal output curve when the sensor is moved form clean air to carbon monoxide (CO) gas environment. Those data was measured after heating period 2.5 minute from high voltage to low voltage.

Environment temperature will effect to sensitivity which relative curve show as Fig.5

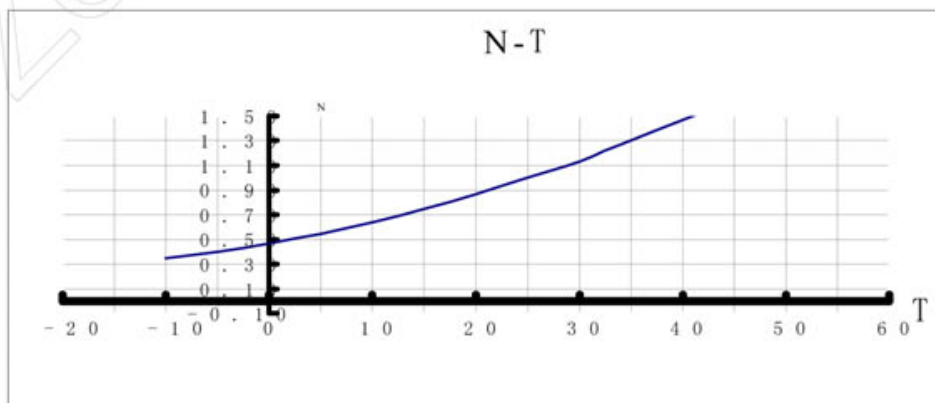

Fig.5

Sensitive layer of HS-134 was made of SnO<sub>2</sub> material. So, it has excellent long term stability.

Its service life can reach 5 years under follow standard operating condition.

### 5.Detail description

#### A. Standard work condition

Symbol	Description	technical condition	Remark
Vc	circuit voltage	5V±0.1	Ac or Dc
VH (H)	Heating voltage (high)	4V±0.1	Ac or Dc
VH (L)	Heating voltage (low)	1.4V±0.1	Ac or Dc
RL	Load resistance	can be adjustable	Ps <25mw
RH	Heating resistance	33 Ω ±5%	A t 2 0 °C temperature
TH (H)	Heating time (high)	60±1 seconds	
TH (L)	Heating time (low)	90±1 seconds	
Ps	Heating consumption	less than 25mw	

#### b. Environment conditions

Symbol	Description	Technical conditions	Remark
Tao	Operating temperature	-20°C-50°C	
Tas	Storage temperature	-20°C-50°C	Advice using scope
RH	Relative humidity	Less than 95%RH	
O <sub>2</sub>	Oxygen concentration	21%(stand condition) Oxygen concentration can affect the sensitivity characteristic	Minimum value is over 2%

#### c. Sentitivity characteristic

Symbol	Parameters	Technical parameters	remark
Rs	Surface resistance Of sensitive body	2-20k	In 100ppm carbon Monoxide
a (300/100ppm)	Concentration slope rate	Less than 0.5	Rs (300ppm)/Rs(100ppm)
Standard operating Condition	Temperature:20°C±2°C Relative humidity:65%±5% RL: 10K Ω ±5% Vc:5V±0.1V VH:4V±0.1V VL:1.4V±0.1V		
Preheat time	No less than 48 hours	Detecting range:20ppm-1000ppm carbon monoxide	

d. Mechanical characteristic

Items	Conditions	Property
Vibration	Frequency 100cpm	Should be conformed to normal sensitivity
	Vertical vibration amplitude 4mm	
	Time 1 hour	
Punch	Acceleration 100G	
	Punch times 5	

e. The relative sensitivity of HS-134 in different gases

Name of gas	With active carbon filter Rs(100ppm)/Rs(100ppmCO)	Without active carbon filter Rs(100ppm)/Rs(100ppmCO)
Methane	Can not measure	Can not measure
Propane	Can not measure	6.58
Isobutane	Can not measure	Can not measure
Hydrogen	6.25	6.0
Alcohol	Can not measure	2.56
Isopropanol	Can not measure	3.48
Methyl benzene	Can not measure	20.98
Ethyl acetate	Can not measure	3.28
Benzene	Can not measure	31.20
Heptane	Can not measure	3.60
Carbon dioxide	Can not measure	Can not measure
Hydrogen Sulphurate	Can not measure	0.02

**6. Sensitivity adjustment**

In different concentrations of carbon monoxide, The resistance value of HS-134 is different.

So, It is necessary to adjust the sensitivity which adjusting step as below:

- a. Connect the sensor to the application circuit.
- b. Turn on the power, preheating over 48 hours (if long time storage).
- c. Adjust the load resistance RL until you get a signal value which is respond to a certain carbon monoxide concentration.

**7. Measurement circuit having temperature and humidity compensation**

Different of temperature and humidity will affect to HS-134 sensitivity.

So, when accurately measuring circuit need compensation function of temperature and humidity. Include the compensation functions, please check follow reference circuit.

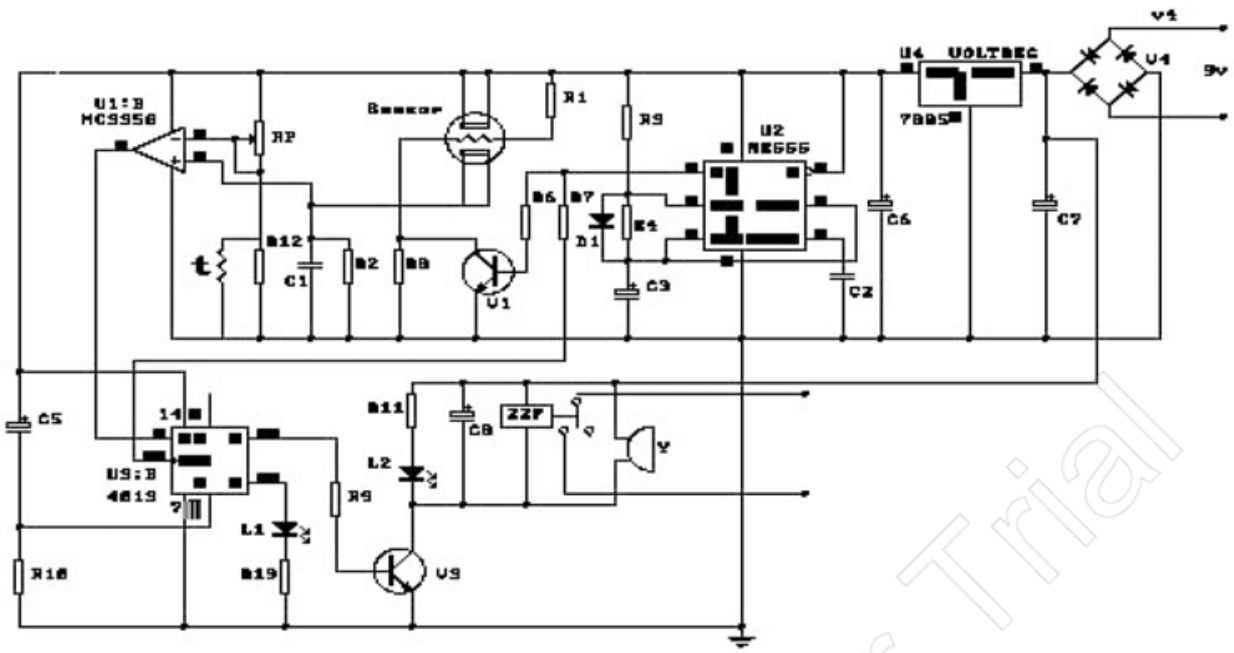

Zeon PDF Driver Trial  
[www.zeon.com.tw](http://www.zeon.com.tw)