

RC MODEL CARS  
**YOKOMO**  
[www.teamyokomo.com](http://www.teamyokomo.com)



**BUD**

**2017 BLACK SERIES**

1/10 SCALE EP TOURING CAR CHASSIS KIT

**2016 IFMAR 15TC WORLD CHAMPION**

この度はヨコモ製R/Cカーキットをお買い求め頂き、誠に有り難うございます。このキットは、ワールドチャンピオン メーカーであるヨコモの高性能・競技用R/Cカーです。本説明書に従った正しい組立・安全な走行をして頂ければ、誰でも手軽に楽しむことができます。

Thank you for purchasing this Yokomo product. This high performance competition kit has been proudly manufactured by Yokomo - World Champion R/C car manufacturer. Proper assembly of this product will provide fun, safe enjoyment.

## R/C カーを安全に楽しんで頂くための 注意事項

お子様(中学生以下)が 組立・走行する際は、必ず保護者の方が付き添い 安全を確認して下さい。

### 組立の注意

- 幼児のいる場所では組み立てないで下さい。小さな部品を飲み込む等、非常に危険です。
- 組立の前に必ず内容をお確かめ下さい。万一不良部品、不足部品などがあった場合は、ヨコモ アフターサービス部までお問い合わせ下さい。
- 組立の前に説明書を最後まで読み、全体の流れをつかむと効率的な組立が出来ます。
- 組み立てる際は、様々な工具が必要になります。安全の為に必ず作業内容に合った工具を使用して下さい。又、カッターナイフ等を使用する際は危険を伴いますので、注意して下さい。
- 部品には様々な素材を使用しています。切削加工された金属パーツ等はエッジが鋭く、慎重な組立が必要となります。ケガをしないように注意して下さい。
- プラスティックパーツなどを切断する際は、切断した部品が飛び危険があるので注意して下さい。
- 回転部や駆動部は出来るだけスムーズに動作するように組み立てて下さい。
- 配線やコード類はきれいにまとめて下さい。回転部分や走行路面にコードが接触すると危険です。又、配線は確実に接続されていないとショートなどの恐れや、性能を十分に発揮出来ない場合があります。
- 必要以上の分解、改造をすると、安全性が低下したり走行性能が十分に発揮出来なくなる場合があります。
- 塗装は、周囲に火気の無いことを確認し、換気の良い場所で行って下さい。

### 走行の注意

- ヨコモ製R/Cカーは競技用の為、時速40kmを超える速いスピードが出るモデルもあります。ルールを守って安全な場所や、R/Cカー用サーキットで走らせて下さい。
- 公道等、周囲の人の迷惑になるような場所では絶対に走らせないで下さい。
- R/Cカーは電波を利用する為、何らかのトラブルで最悪の場合は暴走する事があります。狭い場所や室内は避け、出来るだけ広い、障害物のない場所で走らせて下さい。
- 周囲にR/Cカーを走らせている人がいる場合は、電波が重ならないように、周波数を確認し合って、安全を確かめて下さい。
- R/Cカーは水を嫌います。雨の日や、水たまりのある場所で走らせると、R/Cメカが壊れたり、暴走する危険があります。
- R/Cカーの駆動部分、ギヤやベルト、タイヤなどは高回転で回ります。バッテリーを接続した後は危険ですので、回転部分に手を触れないで下さい。
- 走行後のR/Cカーは各部が高温になる事があります。危険ですので冷却期間をおいてから、メンテナンスなどをして下さい。

### 走らせる手順

- ① タイヤが空転するように、台の上にR/Cカーを置きます。
- ② スピードコントローラのスイッチがOFFになっている事を確認してから、モーターとバッテリーを接続します。
- ③ 送信機のアンテナを伸ばし、スイッチをONにします。(送信機の電圧が下がっていると危険です。常に電圧の高い状態で使用して下さい。)
- ④ 受信機のスイッチをONにします。

### 走行終了手順

- ① スピードコントローラのスイッチをOFFにします。
- ② バッテリーの接続を外します。
- ③ 送信機のスイッチをOFFにし、アンテナを縮めます。

### バッテリーの取り扱い

(バッテリーに付属の説明書に基づき使用して下さい。)

- バッテリーを充電する際は、周囲に燃えやすい物のない安全な場所で行って下さい。又、高温な場所での充電も避けて下さい。
- バッテリーの充電中は充電状況を常に確認して下さい。充電器の誤動作などで過充電すると、最悪の場合は発火する危険性があります。バッテリー温度が50度を越えたら充電を中止して下さい。
- 走行後のバッテリーは高い温度になります。連続使用するとバッテリーを傷める事になりますので、冷却期間を置いてから充電して下さい。又、走行後のバッテリーはコンディション放電する事によって、性能を持続させる事が出来ます。
- 不要になったバッテリーは一般のゴミと一緒に捨てず、お手数でも電池専用の回収箱に捨てて下さい。

### モーターの取り扱い

(モーターに付属の説明書に基づき使用して下さい。)

- 7.2Vのバッテリーでモーターのから回しをすると危険です。モーター内部を破損し部品が飛び出す事も考えられますので、もしモーターのブレークインをする時は、モーターをしっかり固定し3~5V程度でから回して下さい。
- モーターは定期的なメンテナンスが必要です。劣化するとスピードが出なくなったり、走行時間が短くなります。定期的なクリーニングしたり、ブラシが減ってきたら交換する等のメンテナンスをして下さい。
- モーターの性能に合ったギヤ比を選択して下さい。ギヤ比が最適でないとモーターの性能を十分に発揮出来ないだけでなく、他のR/Cメカを壊す原因にもなります。
- 走行後のモーターは非常に高い温度になります。連続走行するとモーターを傷める事になりますので、冷却期間を置いてから走行してして下さい。

## PRECAUTIONS FOR SAFE ENJOYMENT OF YOUR R/C CAR

For children under the age of 13, parental guidance is recommended when running.

### ASSEMBLY PRECAUTIONS

- Do not assemble around small children. The parts can be dangerous if accidentally swallowed.
- Check the contents carefully before assembly. Please contact Customer Support if you happen to notice any defective or missing items.
- You will find the assembly process much easier by carefully reading through the manual, and familiarizing yourself with the instructions.
- Many different tools are required during assembly. For safety purposes, please use suitable tools. Exercise extra caution when using a sharp tool such as a hobby knife.
- Many different materials are used for the parts. Use extra care when handling parts with sharp edges, such as machined metal parts.
- When cutting plastic parts, watch for any flying parts.
- Try to assemble any rotating parts or drivetrain parts as smooth as possible.
- Bundle wires neatly away from the ground or any moving drivetrain components. Make sure that all wires are properly connected to prevent shorting.
- Unnecessary modifications may be unsafe and hinder performance.
- Always paint in a well ventilated area away from flames.

### PRECAUTIONS BEFORE RUNNING

- Yokomo R/C cars are built for competition use, and some models may exceed speeds of 40km per hour. Practice common sense and run the car in open safe places, or R/C car tracks.
- Do not run the car on public roads with high amounts of traffic, or in areas that may cause an inconvenience to people in that area.
- R/C cars are controlled using a radio frequency. In a worst-case scenario, radio interferences may cause loss of control.
- If others near you are running R/C cars, confirm that they are not running on the same frequency.
- R/C cars do not like water. Avoid running on rainy days, or areas with water puddles. Exposure of the electronics to water may cause loss of control or damage to the electronics.
- The drivetrain of an R/C car consists of many moving parts like gears, belts, shafts, and tires. Avoid touching these areas when the battery is connected.
- Many parts of an R/C car will become hot after running. Allow the parts to sufficiently cool before conducting any maintenance.

### BEGINNING A RUN

- ① Place the R/C car on a stand so the wheels are off the ground.
- ② Confirm that the speed controller switch is OFF, and connect the motor and battery.
- ③ Extend the transmitter antenna and turn the switch ON. (It is unsafe to use a transmitter with low voltage. Make sure that the transmitter batteries are good before running)
- ④ Turn the speed controller switch ON.

### FINISHING A RUN

- ① Turn the speed controller switch OFF.
- ② Disconnect the battery.
- ③ Turn the transmitter switch OFF, and retract the antenna.

### BATTERY USAGE

(Carefully read the instruction included with the batteries.)

- When charging batteries, make sure that the surrounding area is void of anything highly flammable. Also avoid charging in high-temperature locations.
- When charging batteries, frequently monitor the charging it catch on fire. If the battery reaches 50 degrees Celcius or more, stop charging.
- Batteries will become hot after running. Continuous use of the battery pack may result in damage to the cells. Allow the battery too cool down before re-charging. Using a battery conditioner after running may prolong the life and performance of the battery.
- Please do not discard old battery packs in the trash. Although inconvenient, please locate a battery disposal center.

### MOTOR USAGE

(Carefully read the instruction included with the motor.)

- Connecting a 7.2V battery directly to the motor can be very dangerous. This may cause the internal parts of the motor to break apart, causing some parts to fly out of the motor. To break-in the motor, safely secure the motor and run the motor at about 3-5V.
- Motors require periodic maintenance. Slower speeds and decreased run times may indicate a worn-out motor. Periodically clean the motor and change the brushes when needed.
- Choose a gear ratio that matches the power characteristics of the motor. Using a gear ratio unsuited to the characteristics of the motor will not only prevent the motor from performing at its optimum, but may even cause damage to the other electronics.
- Motors will generally become very hot after running. Continuous running will reduce the life of the motor. Allow the motor to sufficiently cool between each run.

## 【組み立てに必要な物】

### ACCESSORIES AND TOOLS NEEDED FOR [MRTC BD8] ASSEMBLY

#### ■ 走行の為に別にお買い求め頂く物 ■

##### ADDITIONAL ITEMS REQUIRED FOR USE (NOT INCLUDED IN KIT)

- 2チャンネルプロポ (1サーボ 1アンプ仕様)  
TWO CHANNEL R/C SURFACE RADIO SYSTEM  
AND ELECTRONIC SPEED CONTROL
- 走行用 角型Li-Poバッテリー  
SQUARE EDGE Li-Po BATTERY PACK
- 走行用バッテリー充電器  
BATTERY CHARGER
- 走行用モーター  
MOTOR
- タイヤ&ホイール  
TIRES & WHEEL
- 走行用ボディー  
BODY
- ボディー塗装用カラー  
BODY SPRAY PAINT
- バッテリー固定用ストラッピングテープ  
BATTERY STRAPPING TAPE
- 64ピッチ ピニオンギヤ  
64P PINION GEAR

#### ■ 別途用意する工具 ■

##### ASSEMBLING TOOLS REQUIRED (NOT INCLUDED IN KIT)



ドライバー (大,小)  
SCREW DRIVER (SMALL & LARGE)



六角レンチ (1.5mm&2.0mm)  
ALLEN WRENCH (1.5mm & 2.0mm)



ナットドライバー (7.0mm)  
NUT WRENCH (7.0mm)

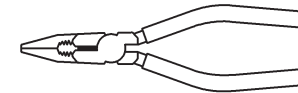

ラジオペンチ  
NEEDLE NOSE PLIERS

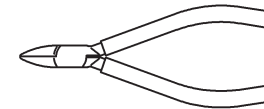

ニッパー  
SIDE CUTTER

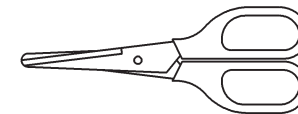

ハサミ  
SCISSORS

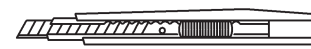

カッター  
HOBBY KNIFE

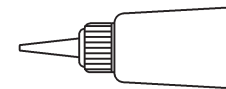

瞬間接着剤  
CA (Cyanoacrylate) GLUE

#### ■ キットに入っている工具 ■

##### TOOLS (INCLUDED)



六角レンチ  
ALLEN WRENCH  
(3.0mm)



ターンバックルレンチ  
TURNBUCLE WRENCH

**[MRTC BD8]の性能を十分に発揮させる為にイラストを良く参照し説明の順番に従って確実に組み上げて下さい。**

**For assembly, follow the figures and the instructions closely so that your [MRTC BD8] will perform at its best!!**

**[ Bag-1 Contents ]**

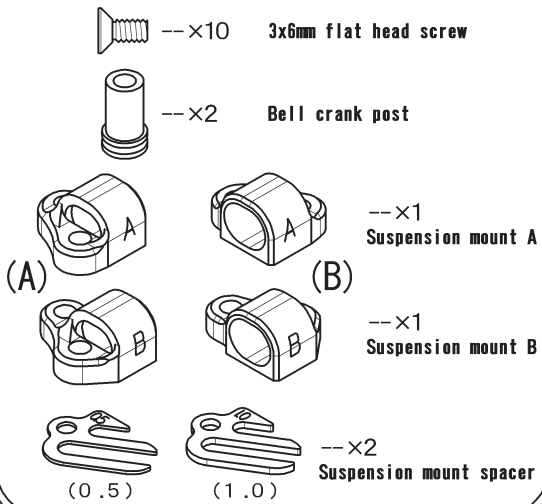

**[ Bag-2 Contents ]**

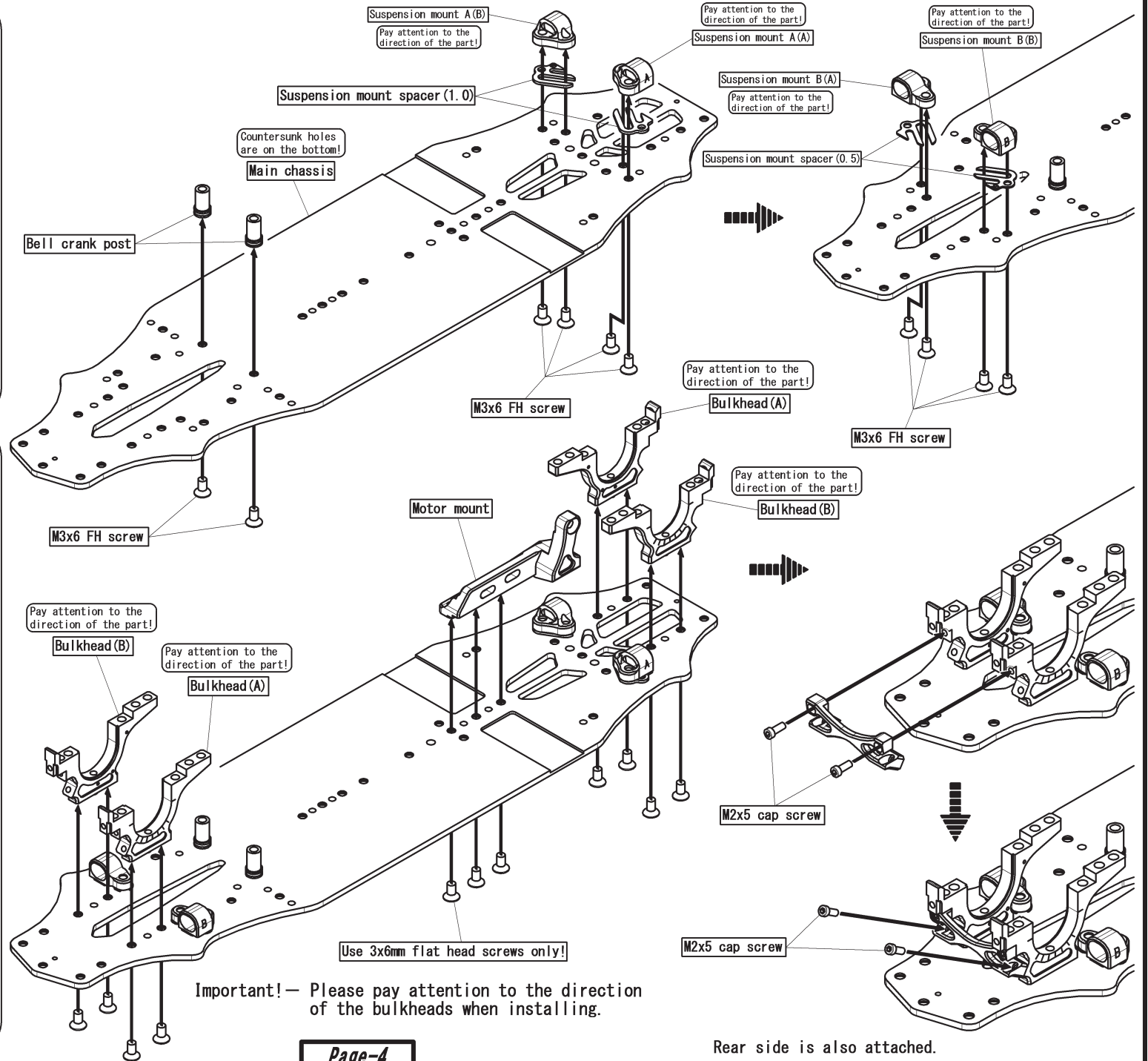
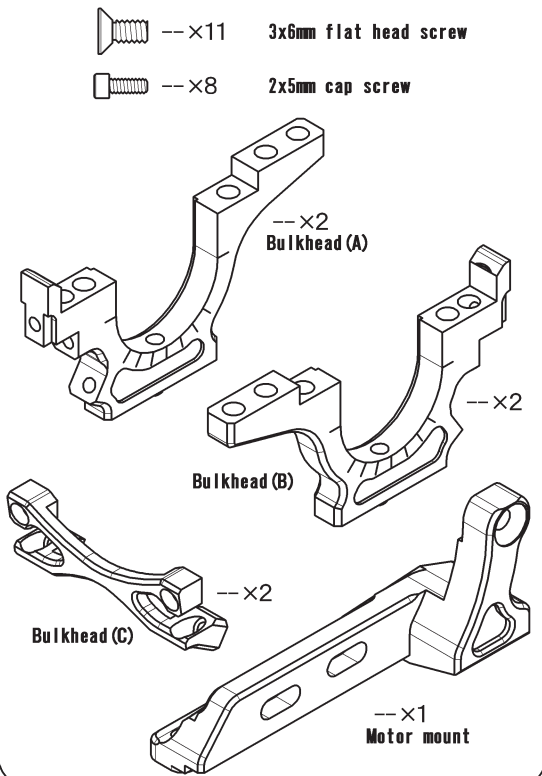



[ Bag-3 Contents ]

[ SOLID AXLE PARTS ]

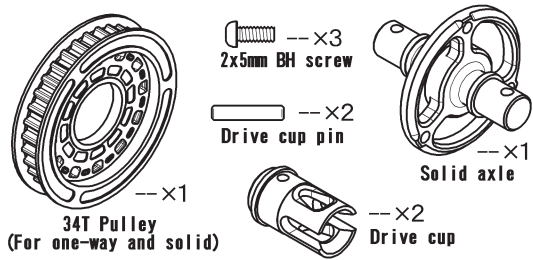

[ CENTER GEAR PARTS ]

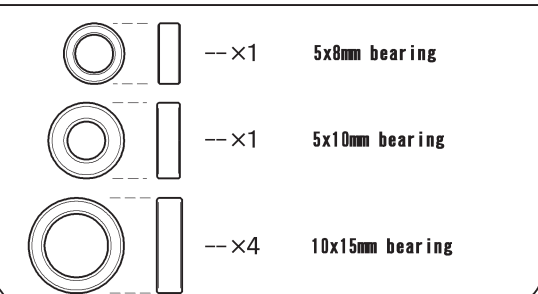
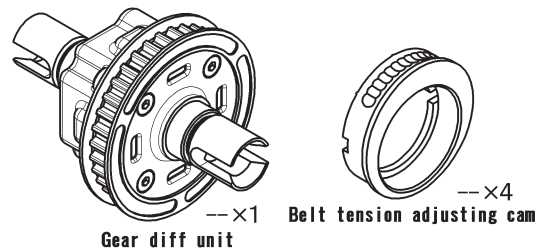
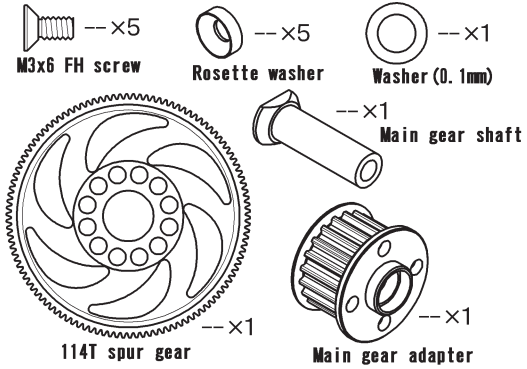

Solid Axle Assembly

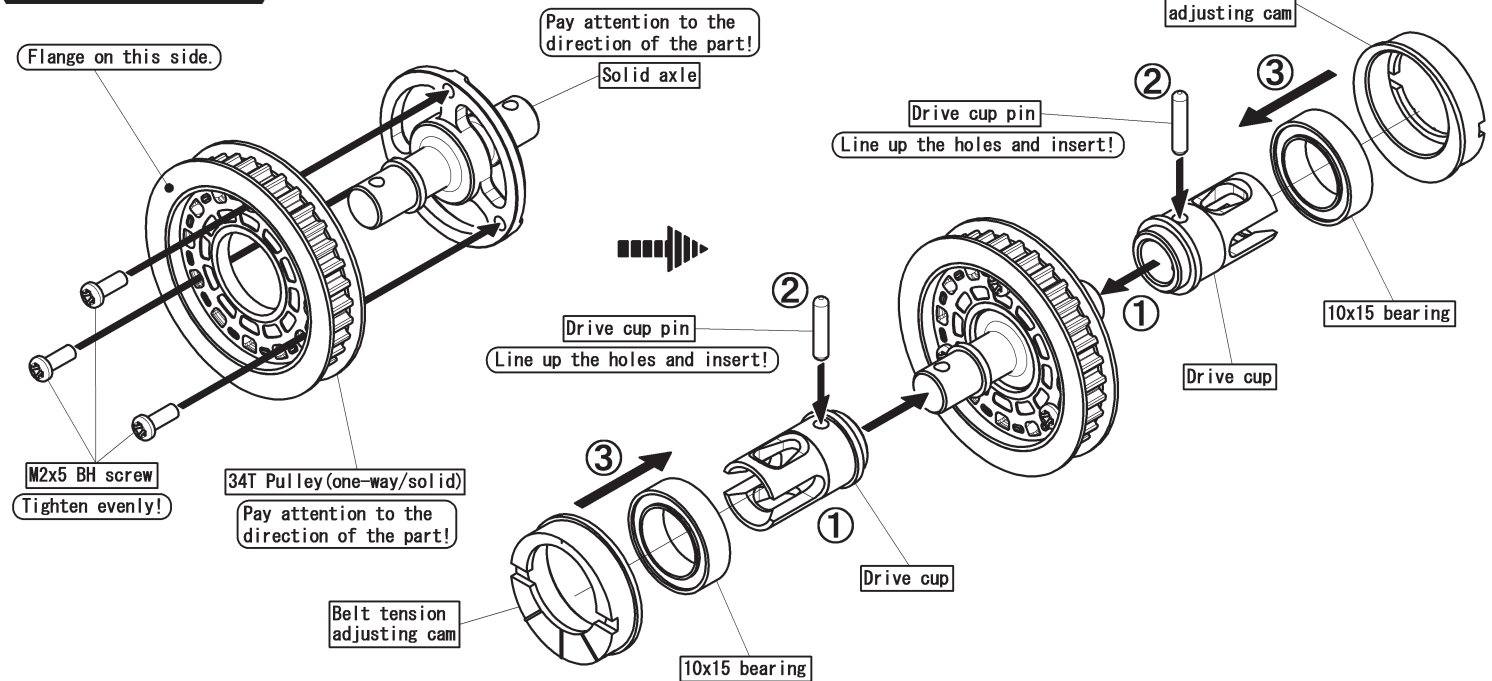

Center Gear Assembly

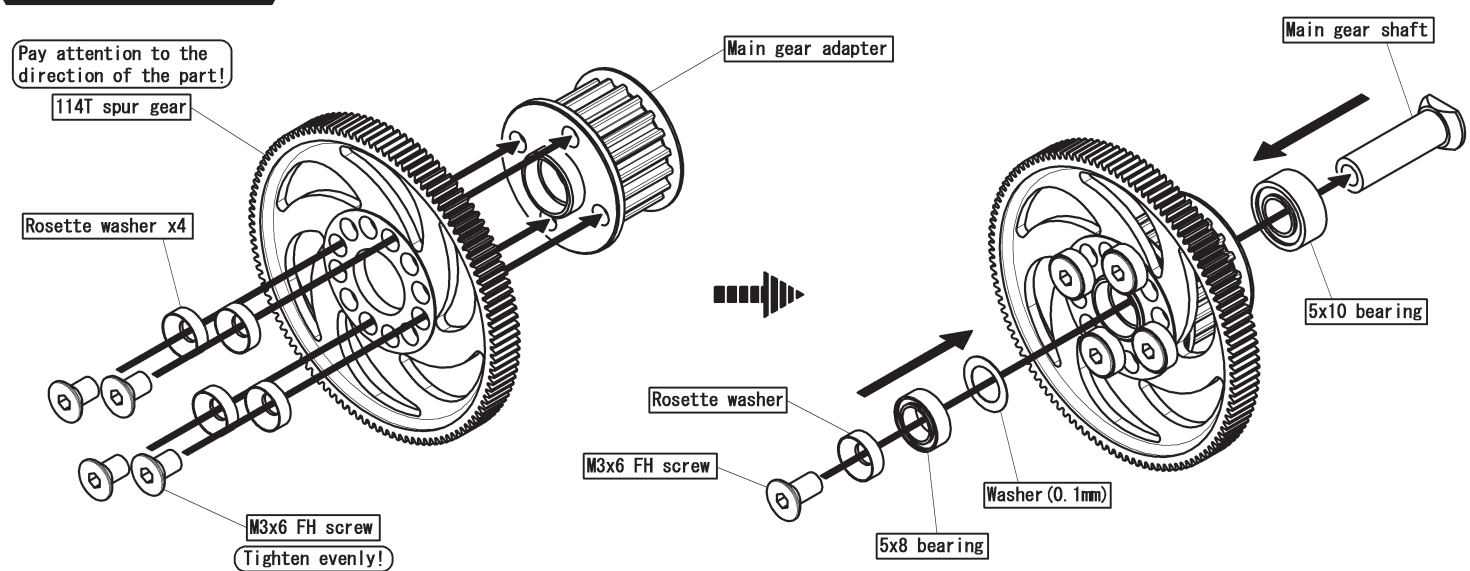

**Gear Diff Unit Assembly**

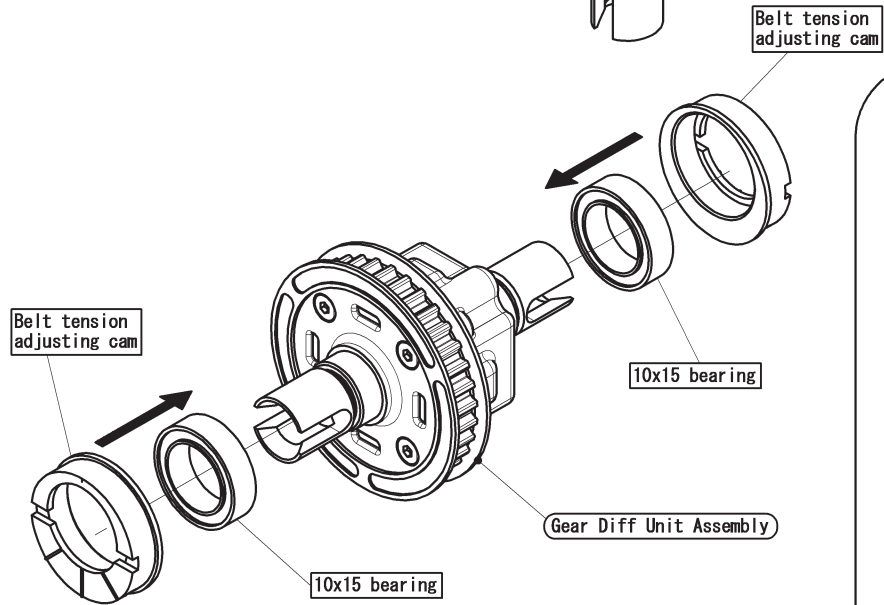
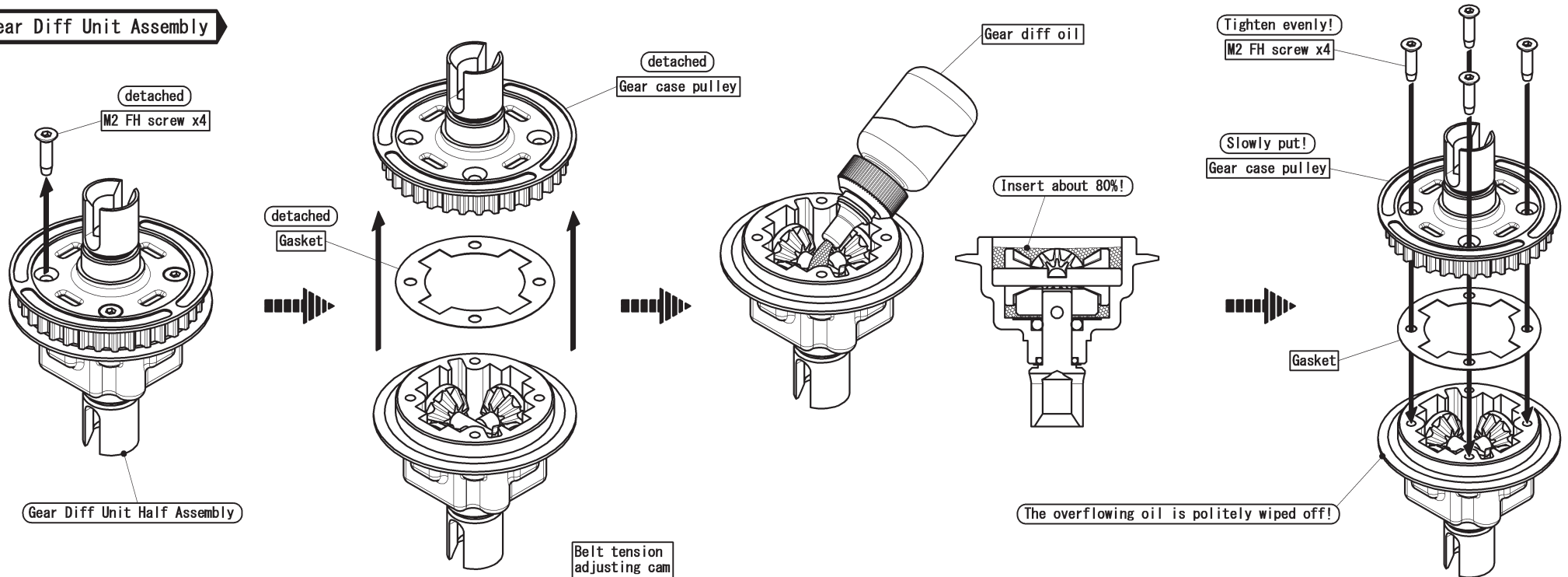

**[ Oil Bag ]**  
 #2000 gear diff oil --x1

**Gear Diff Unit Deal Drawing**

Perform when maintenance is required.

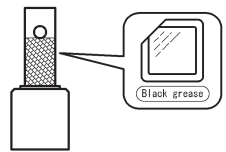
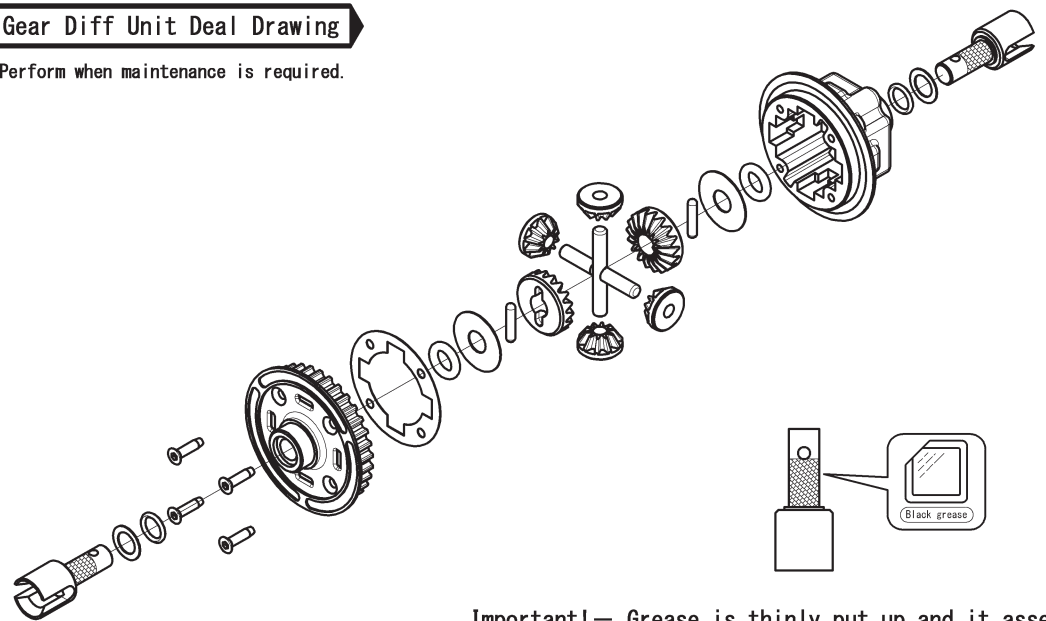

Important!— Grease is thinly put up and it assembles it again when resolving it.

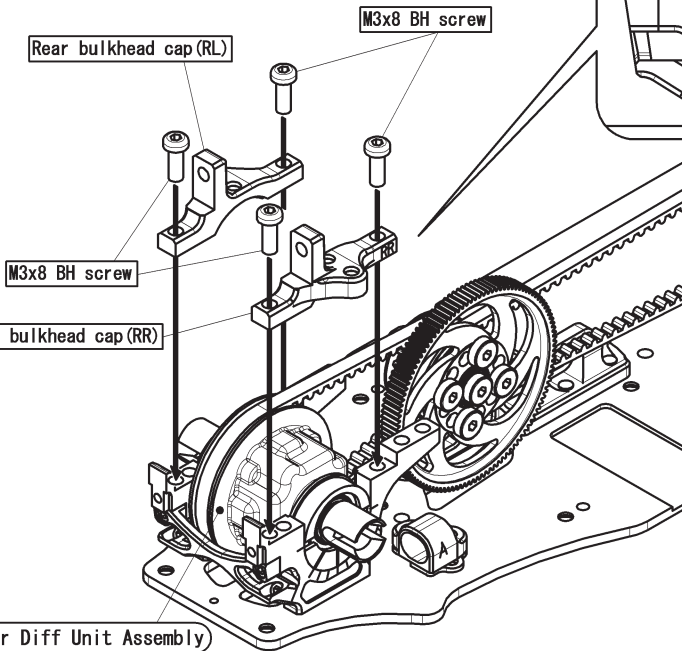
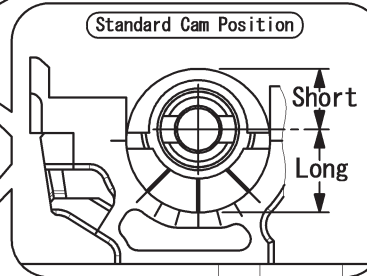
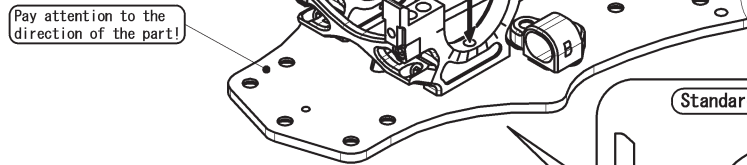
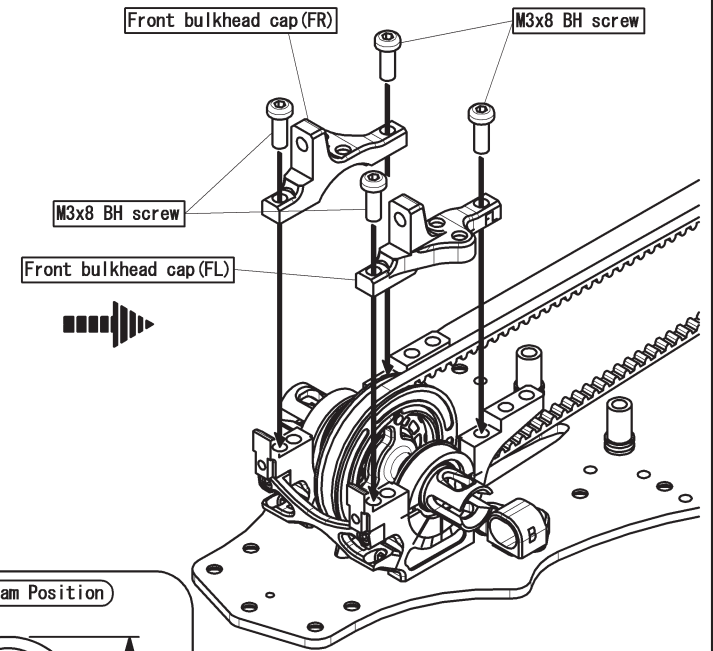
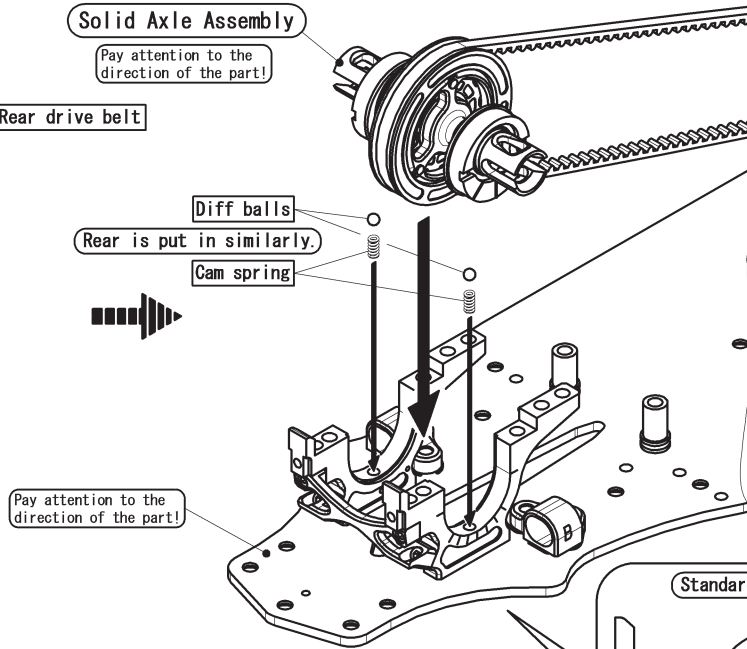
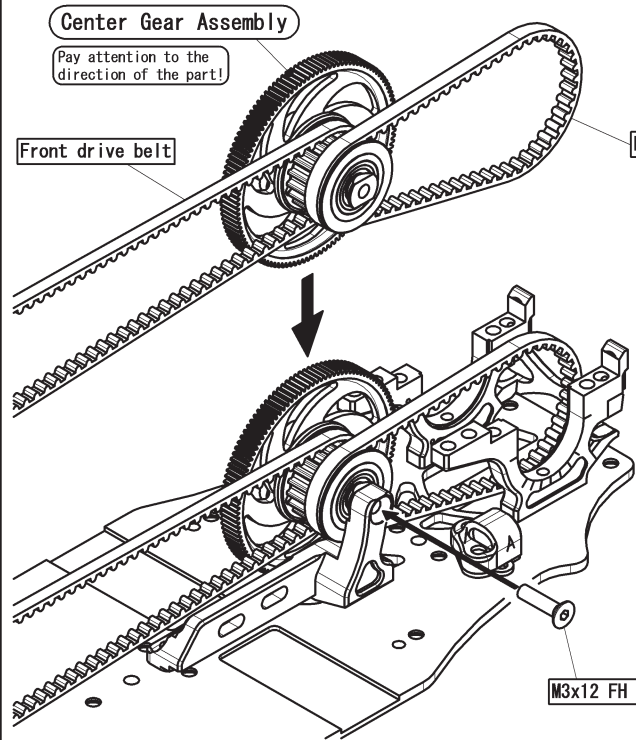

To adjust belt tension, slightly loosen the bulkhead cap screws, and reposition the cams as shown in the illustration. (Make sure that the left and right cams are adjusted to the same position.)

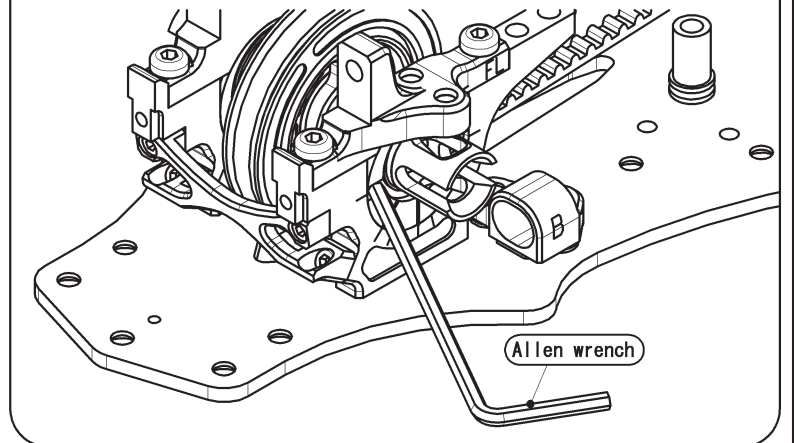

**[ Bag-4 Contents ]**

--x1 Front drive belt

--x1 Rear drive belt

**[ Bag-5 Contents ]**

--x1 3x12mm flat head screw

--x8 3x8mm button head screw









--x4 Cam spring

--x4 Diff ball

--x1 Front bulkhead cap

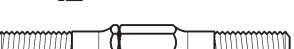
--x1 Rear bulkhead cap

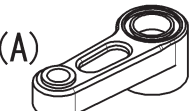
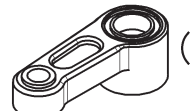
**[ Bag-6 Contents ]**

-  --x2 3x8mm flat head screw
-  --x2 3x6mm button head screw
-  --x1 Ball stud (SS)
-  --x2 Ball stud
-  --x1 16mm turnbuckle
-  --x2 39mm turnbuckle
-  --x4 Plastic ball cup
-  --x2 Plastic open ball cap
-  --x1 Bell crank (A)
-  --x1 Bell crank (B)
-  --x1 Center link
-  --x1 Turnbuckle wrench

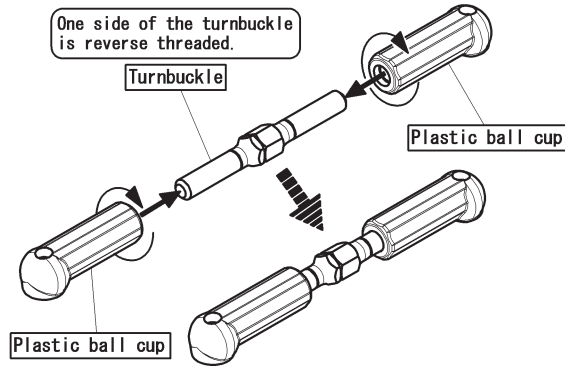

Assemble the tie-rod by attaching a plastic ball cup to both ends of the turnbuckle.

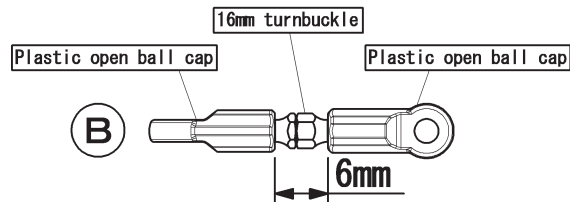
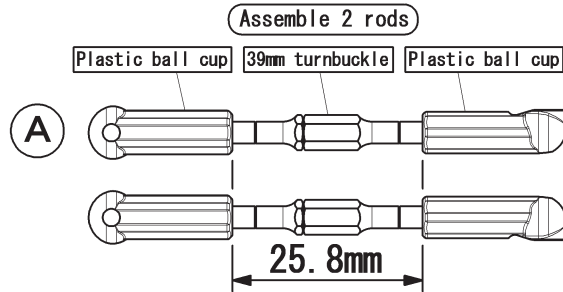
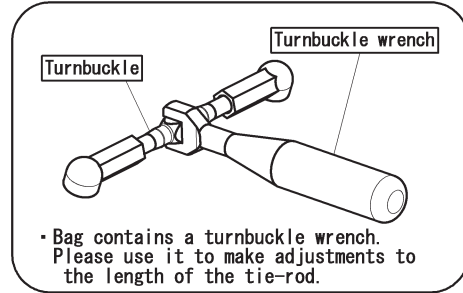



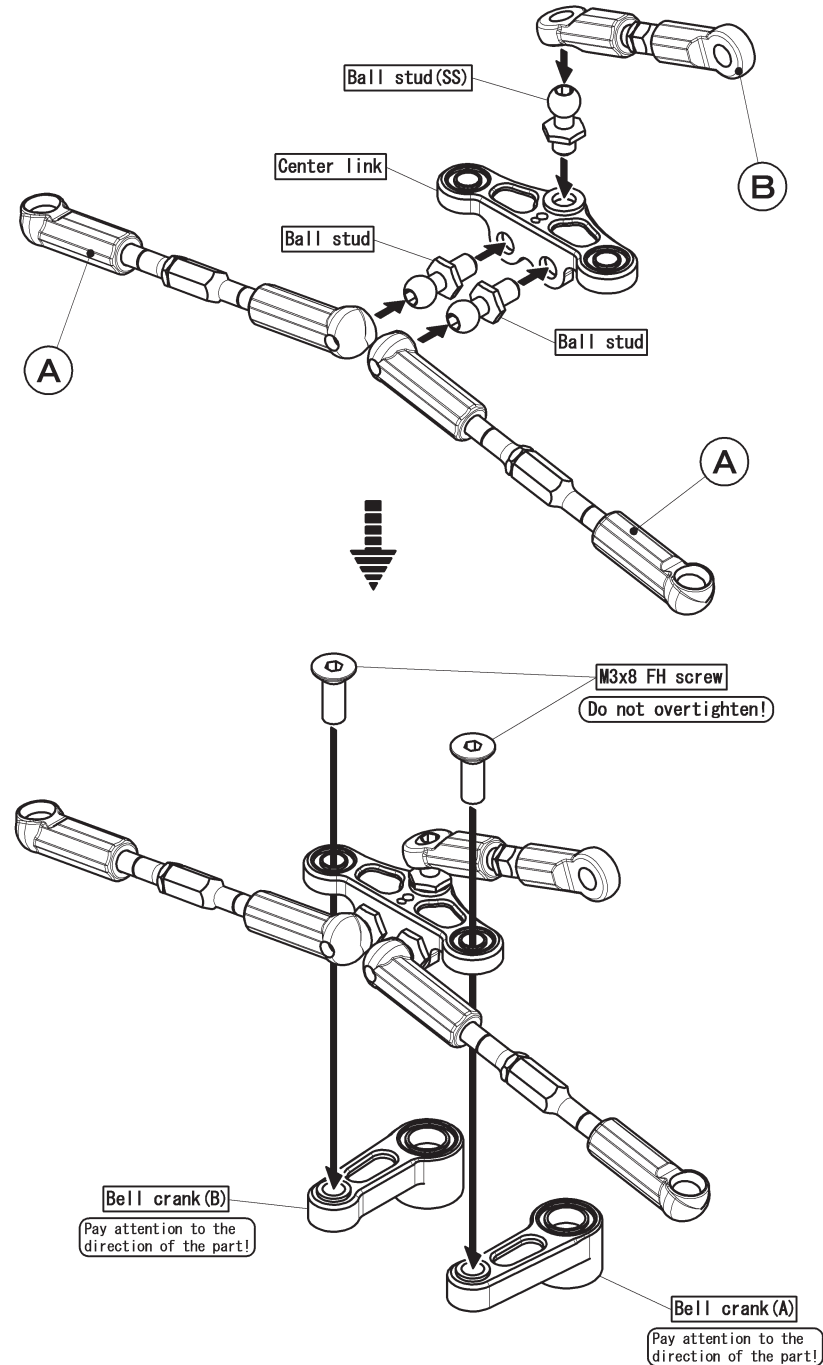



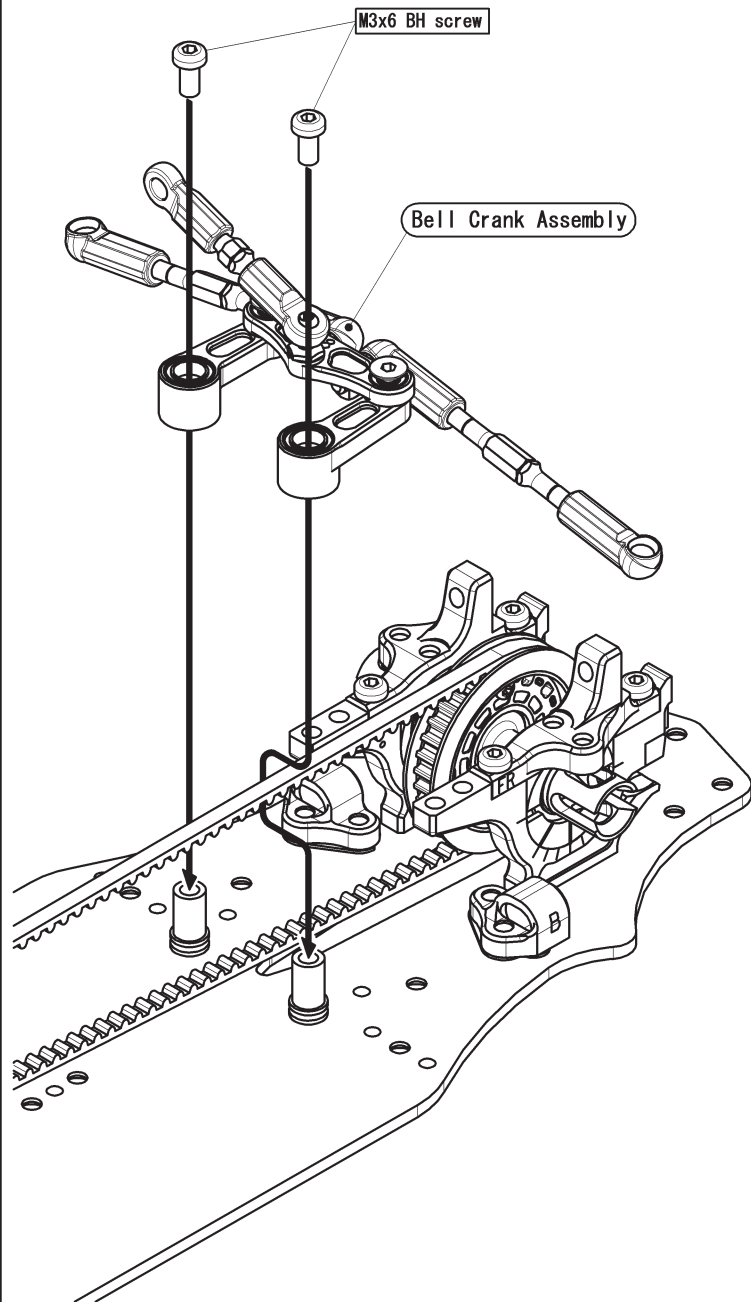





Length tuning is required by the servo to be used.





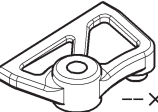
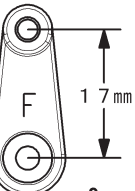
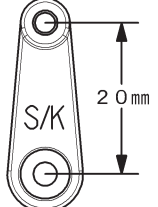

**[ Bag-7 Contents ]**

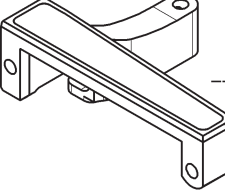
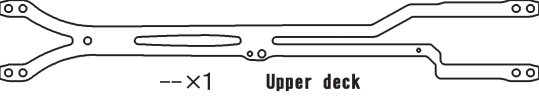
-  --x3 3x5mm flat head screw
-  --x1 3x6mm flat head screw
-  --x8 3x6mm button head screw
-  --x2 3x8mm button head screw
-  --x1 3x8mm set screw
-  --x1 Ball stud
-  --x2 Washer (Black)
-  --x1 O-ring (black)
-  --x1 Antenna mount
-  --x1 Battery guide
-  17mm Servo horn (3 different types included.)
-  20mm Servo horn (3 different types included.)
-  --x1 3x10mm tapping screw (Small head)
-  --x1 2.6x10mm tapping screw
-  --x1 3x10mm screw
-  --x1 Servo mount
-  --x1 Upper deck



Mark	Manufacturer
F	Futaba
H	Hitec
S/K	Sanwa, KO, JR

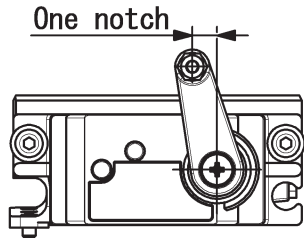

The included servo horns are marked with a letter designating servo compatibility. Select the servo horn matching the servo being used. As shown in the illustration, center the servo, and attach the servo horn, offset by one notch.

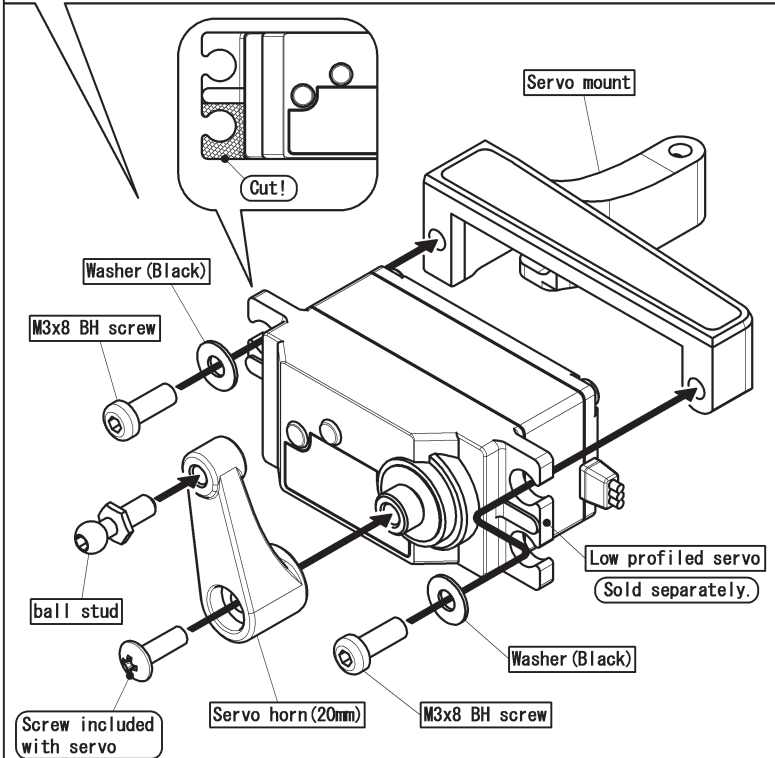

- ① Attach the servo horn to the servo using the same (or similar) screw included with the servo unit. (3 different screws are included in the kit: 2.6x10mm tapping screw, 3x10mm tapping screw, 3x10mm screw)
- ② Make sure that the servo is centered before attaching the servo horn lower. (Refer to your radio manual for more information.)
- ③ Kit includes 3 servo horns. Select the servo horn designated for use with the servo being used. (Using an incorrect servo horn may result in damage to the servo.)

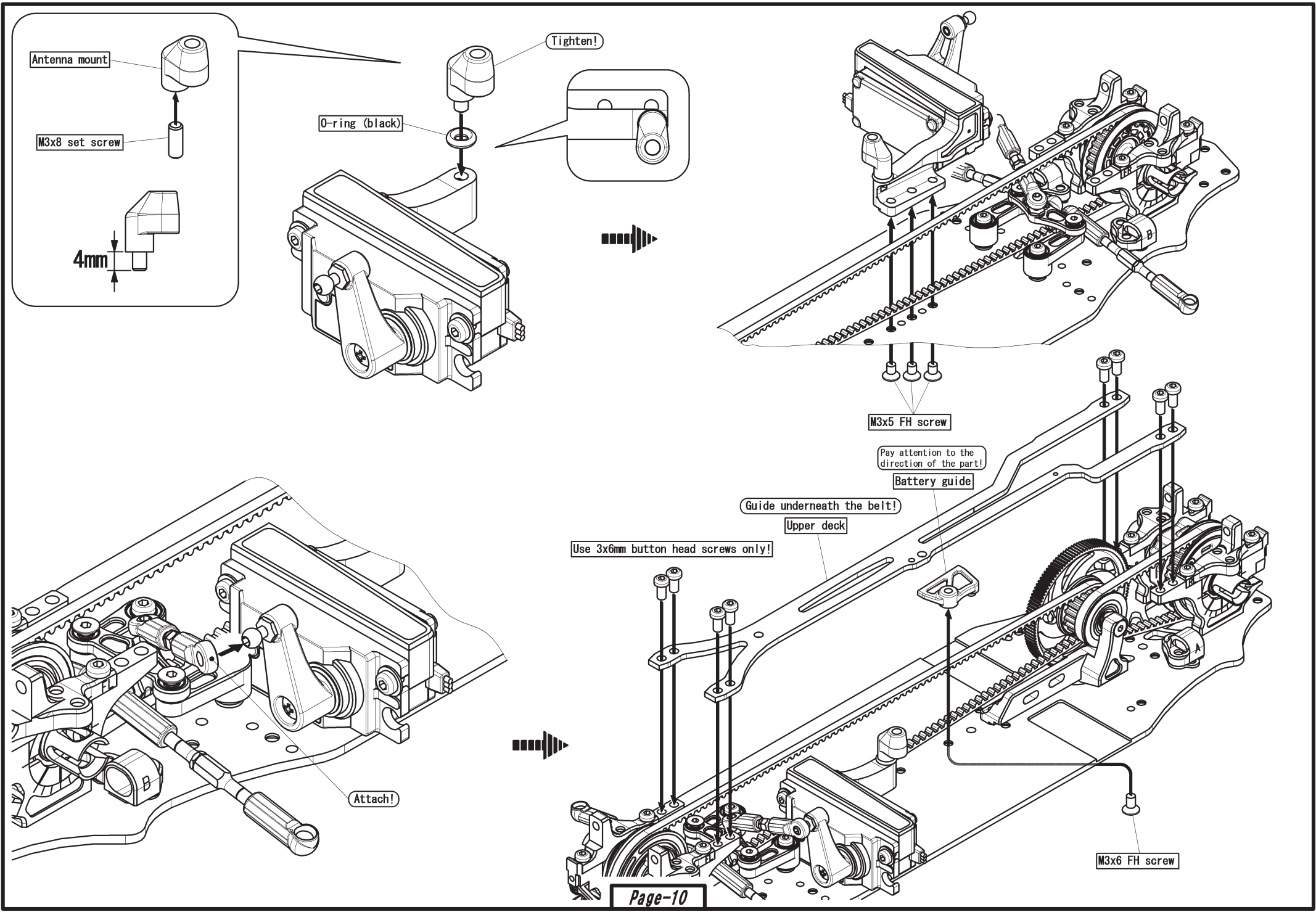

**[ Bag-8 Contents ]**

 --x4 3x8mm flat head screw

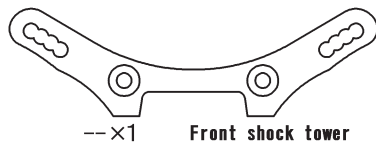
 --x1 Front shock tower

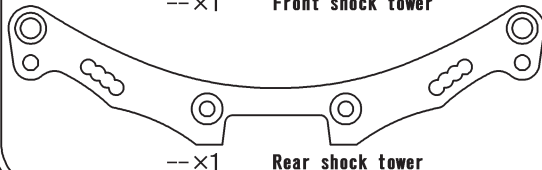
 --x1 Rear shock tower

**[ Bag-9 Contents ]**

 --x4 Ball stud

 --x4 30mm turnbuckle

 --x4 3mm spacer

**Remaining parts from [ Bag-6 Contents ]**

 --x8 Plastic ball cup

One side of the turnbuckle is reverse threaded.

30mm turnbuckle

Plastic ball cup

Plastic ball cup

C

14.5mm

Assemble 2 rods

D

13mm

Assemble 2 rods

**Installing on front shock tower**

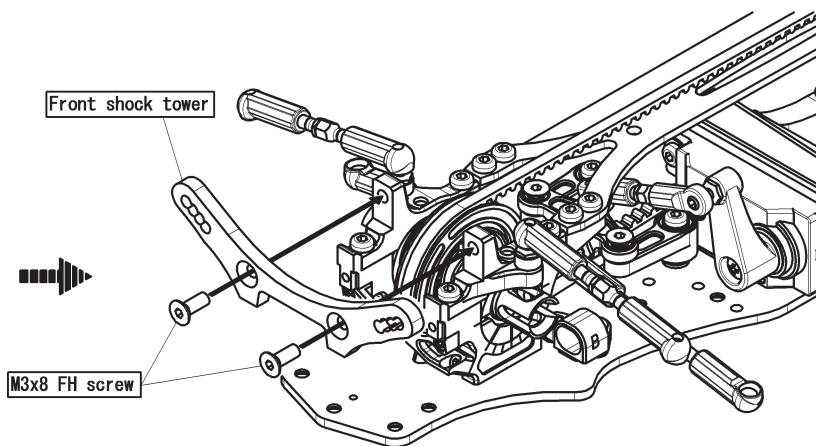
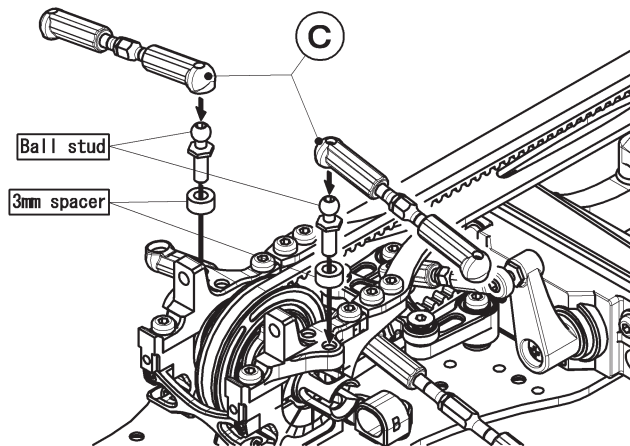

**Installing on rear shock tower**

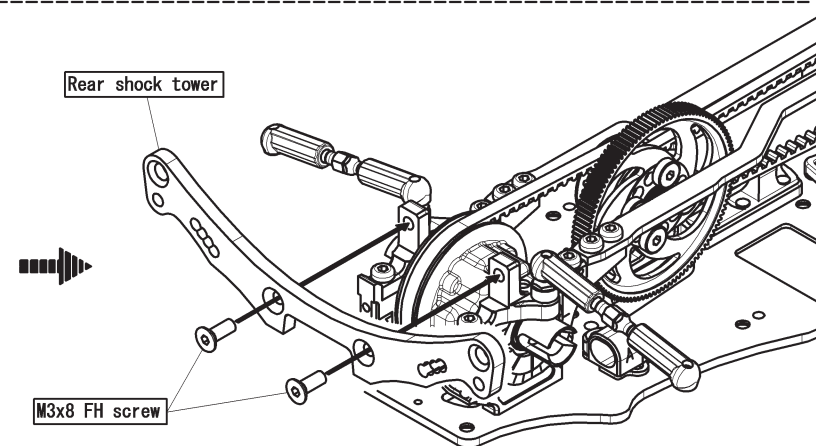
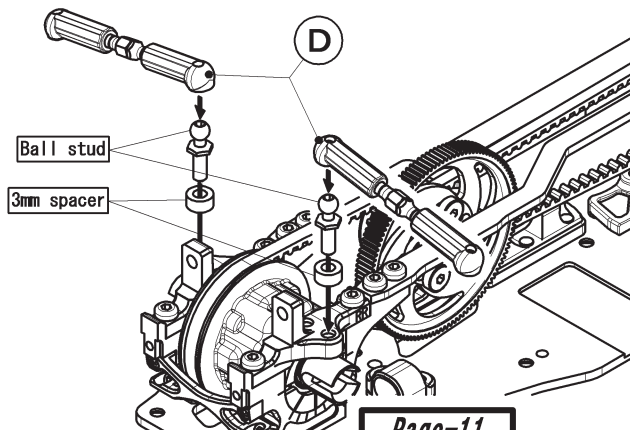

**Important!**

To attach an arm inside, (ZC-206MH) is required separately.



### [ Bag-10 Contents ]

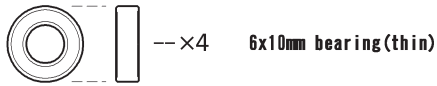
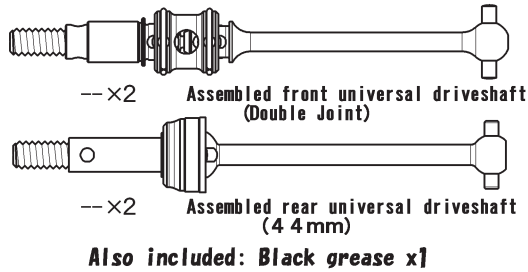

### [ Bag-11 Contents ]

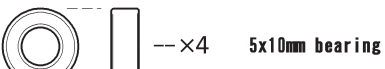
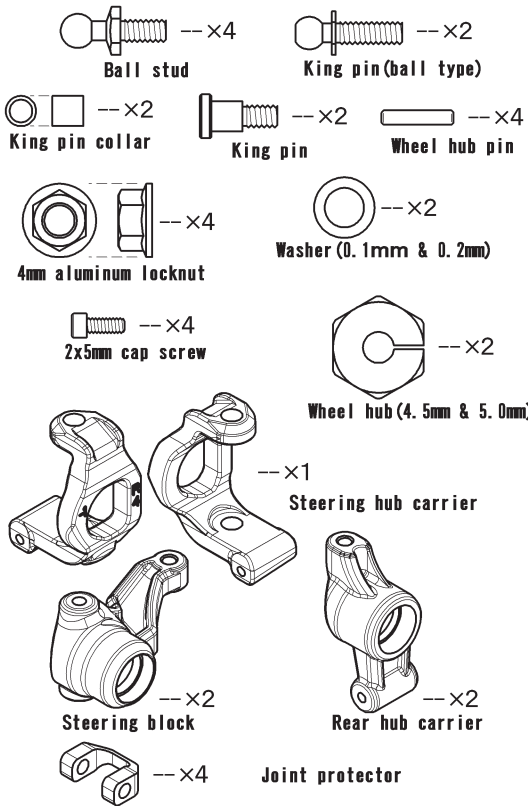

### Front Hub Carrier Assembly

Assemble 2 sets

(The steering hub carriers are different left and right.)

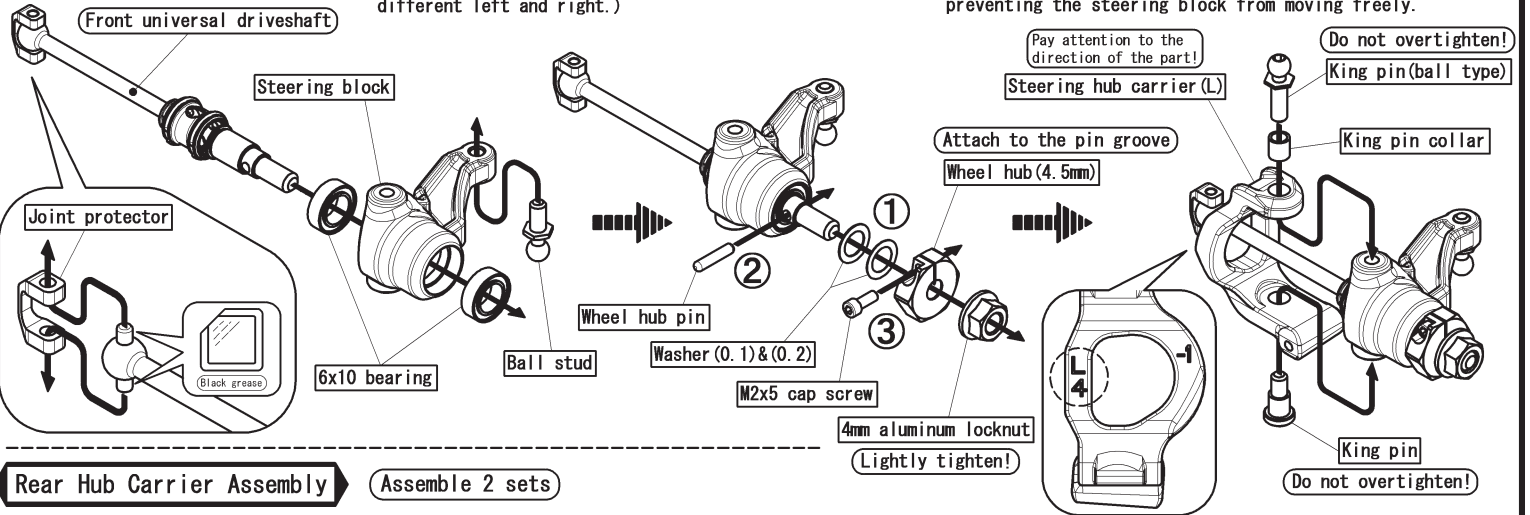

### Rear Hub Carrier Assembly

Assemble 2 sets

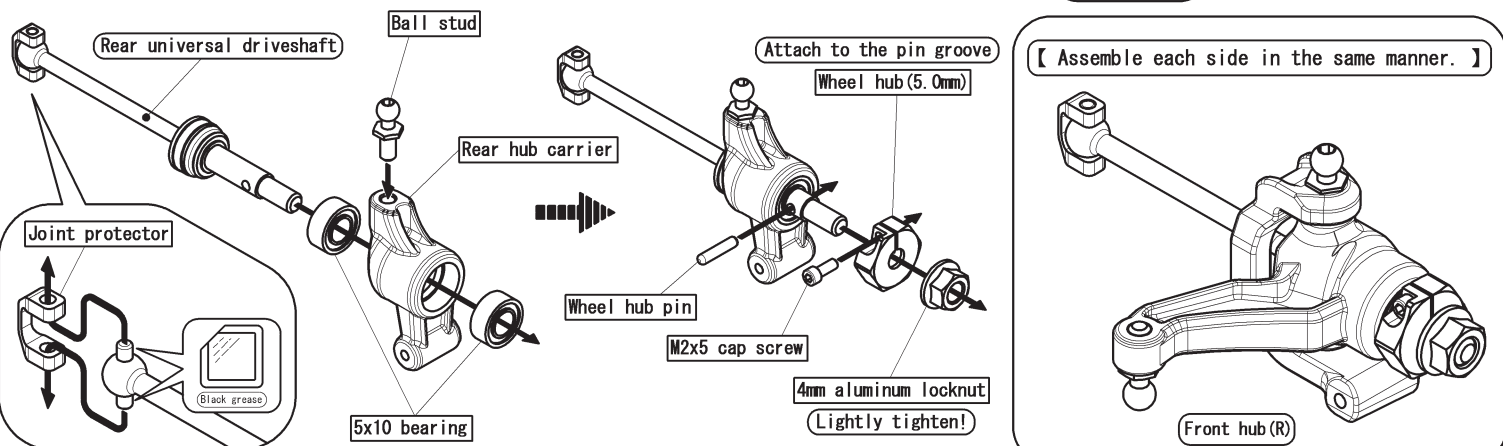

### Universal Driveshaft Assembly

Perform when maintenance is required.

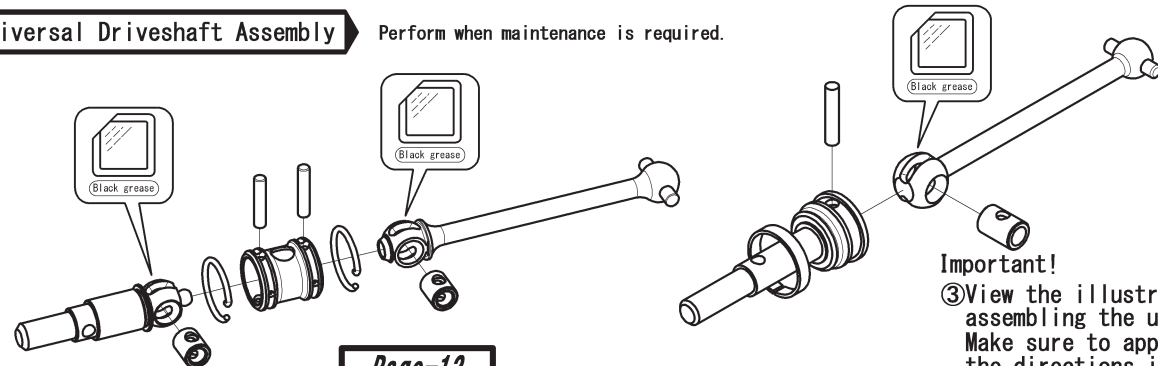



















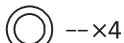

Important!

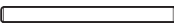
③View the illustration on the left when assembling the universal drive shafts. Make sure to apply black grease. Follow the directions in reverse for disassembly.

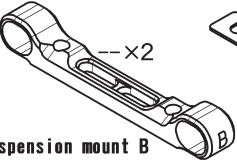
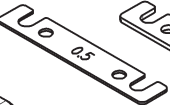
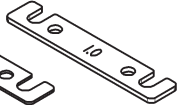

# [ Bag-12 Contents ]

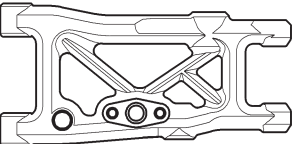
-  --x4
-  --x4
-  --x4
-  --x4
-  --x2
-  --x2
-  --x2
-  --x2
-  --x2
-  --x2
-  --x4
-  --x2
-  --x4
-  --x8
-  --x4
-  --x4
-  --x2
-  (0.5)
-  (1.0)
-  --x2
-  --x2
-  --x2 (Included with the suspension arms.)
-  --x2
-  --x2

## Front Assembly

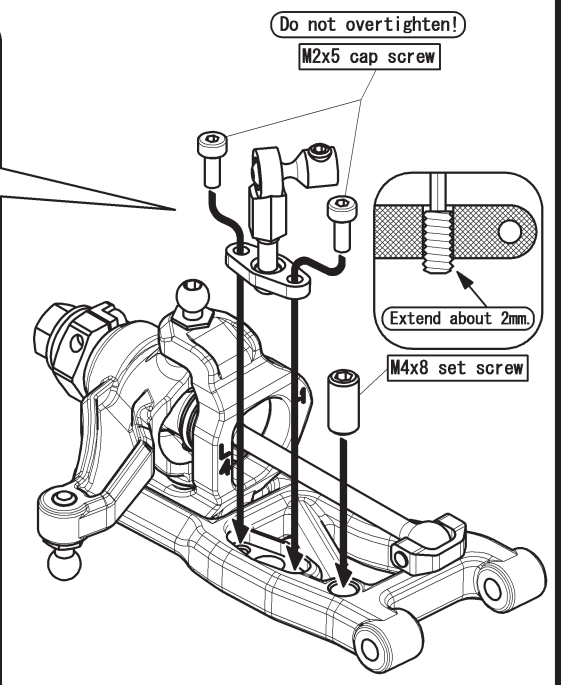
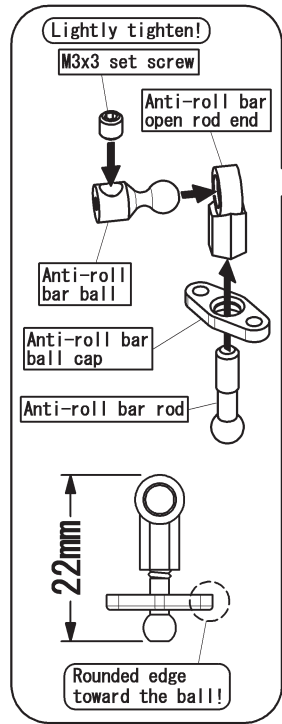
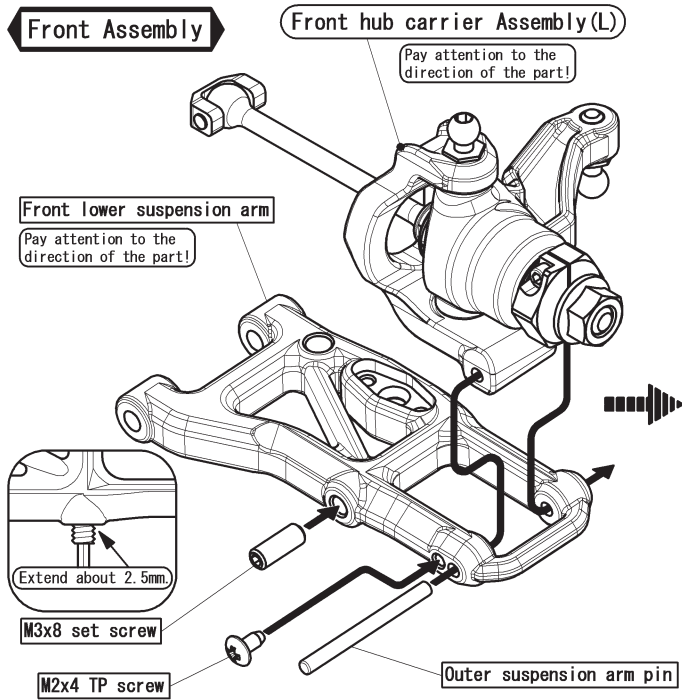

[ Assemble each side in the same manner. ]

## Rear Assembly

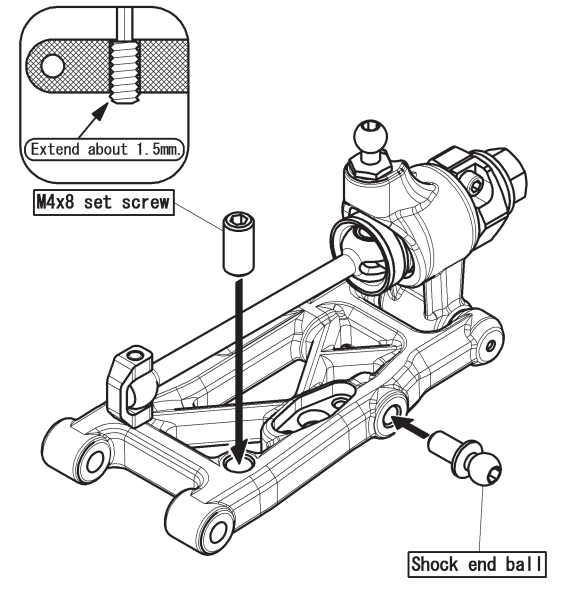
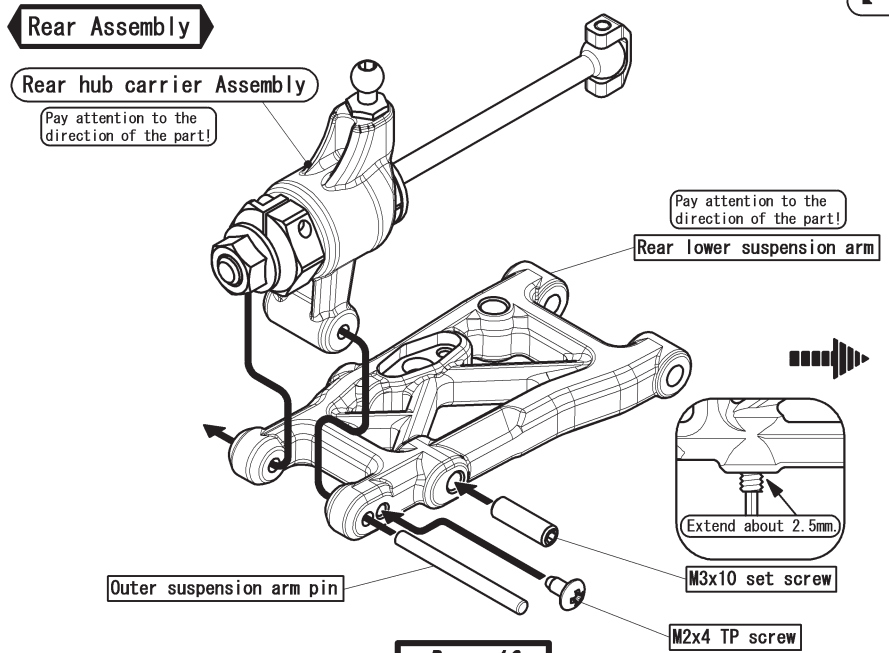

### Front Assembly

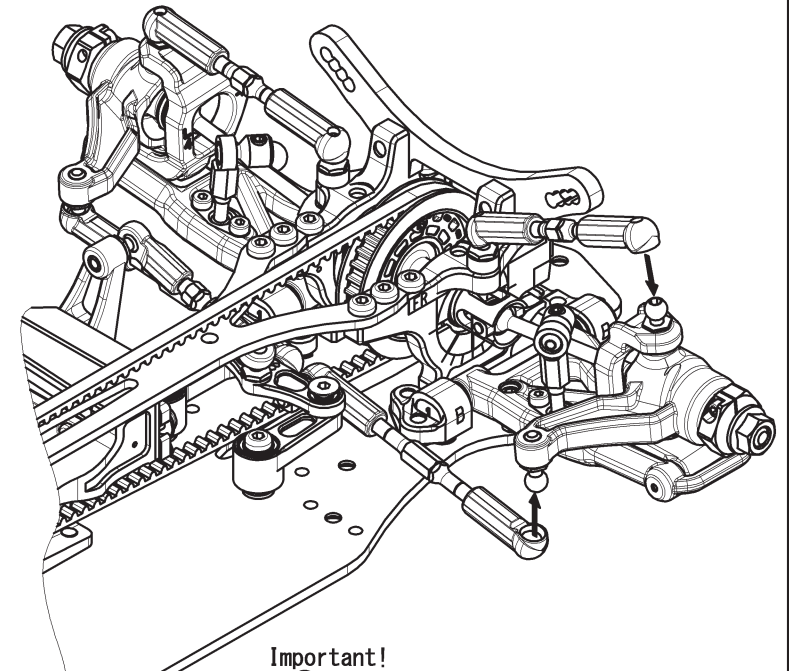
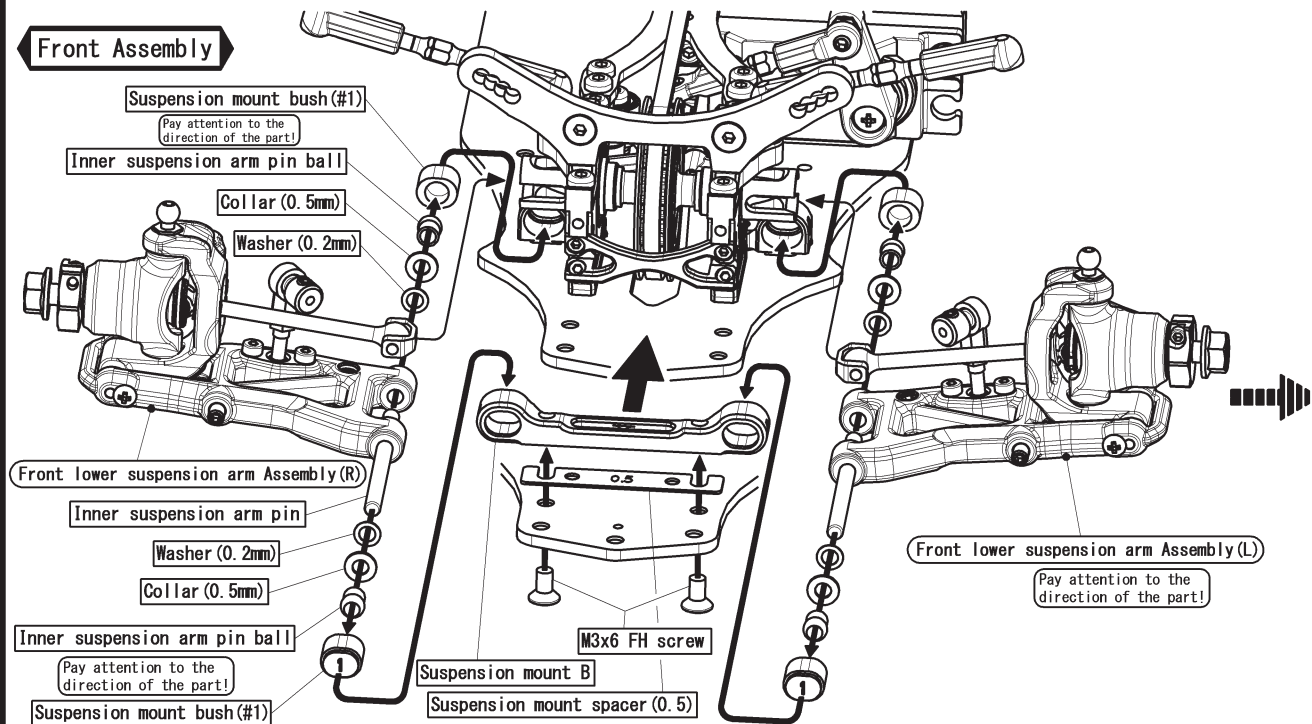







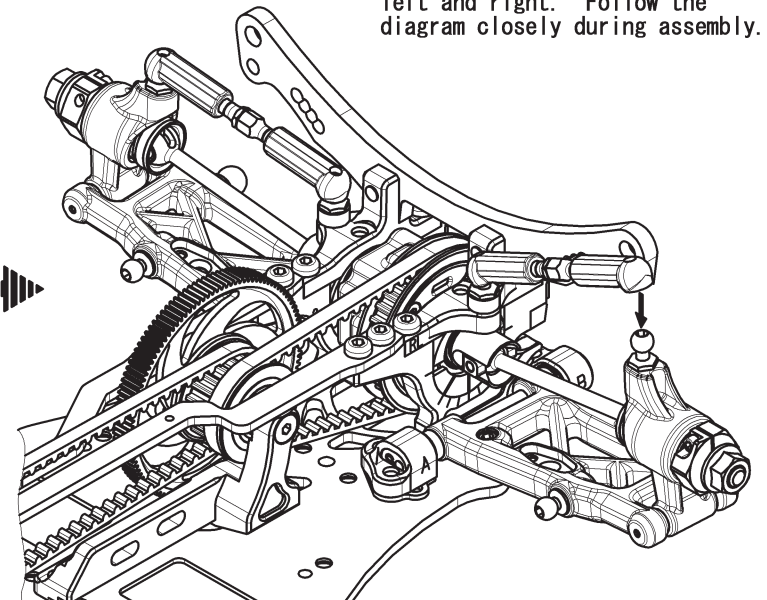
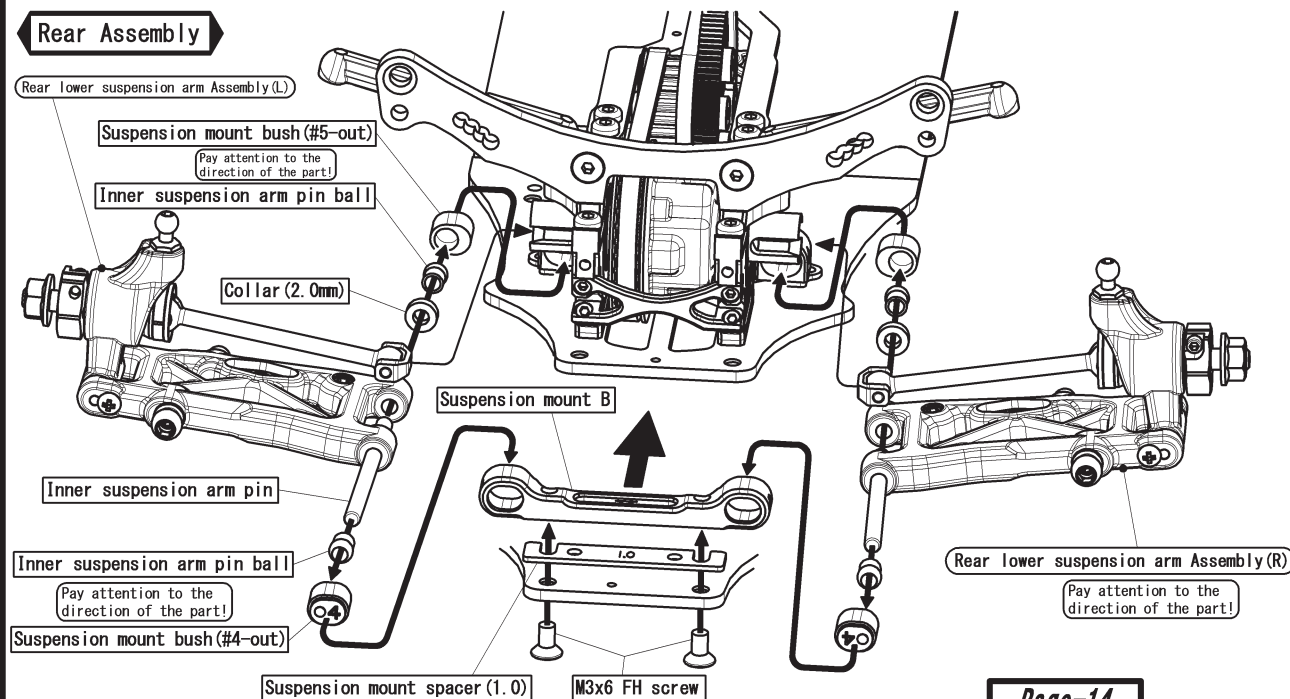









### Important!

- ① Always apply black grease to the universal driveshaft pins.
- ② The lower suspension arms assembled in the previous step are different left and right. Follow the diagram closely during assembly.

### Rear Assembly

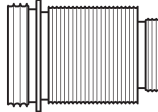

# [ Bag-13 Contents ]

-  --x4    3x6mm button head screw
-  --x4     --x8    2mm E-ring
-  --x4     --x4    O-ring Collar
-  --x4     --x4    Cap nut
-  --x4     --x4    Spring cup
-  --x4     --x8    Shock end ball
-  --x4     --x4    O-ring (13mm diameter)
-  --x4    Diaphragm
-  --x4    Shock shaft
-  --x4    Shock body
-  --x4    Shock spring

Also included: Allen wrench(3.0mm) x1

# [ Oil Bag ]

#400 shock oil --x1

## Assemble 4 shocks

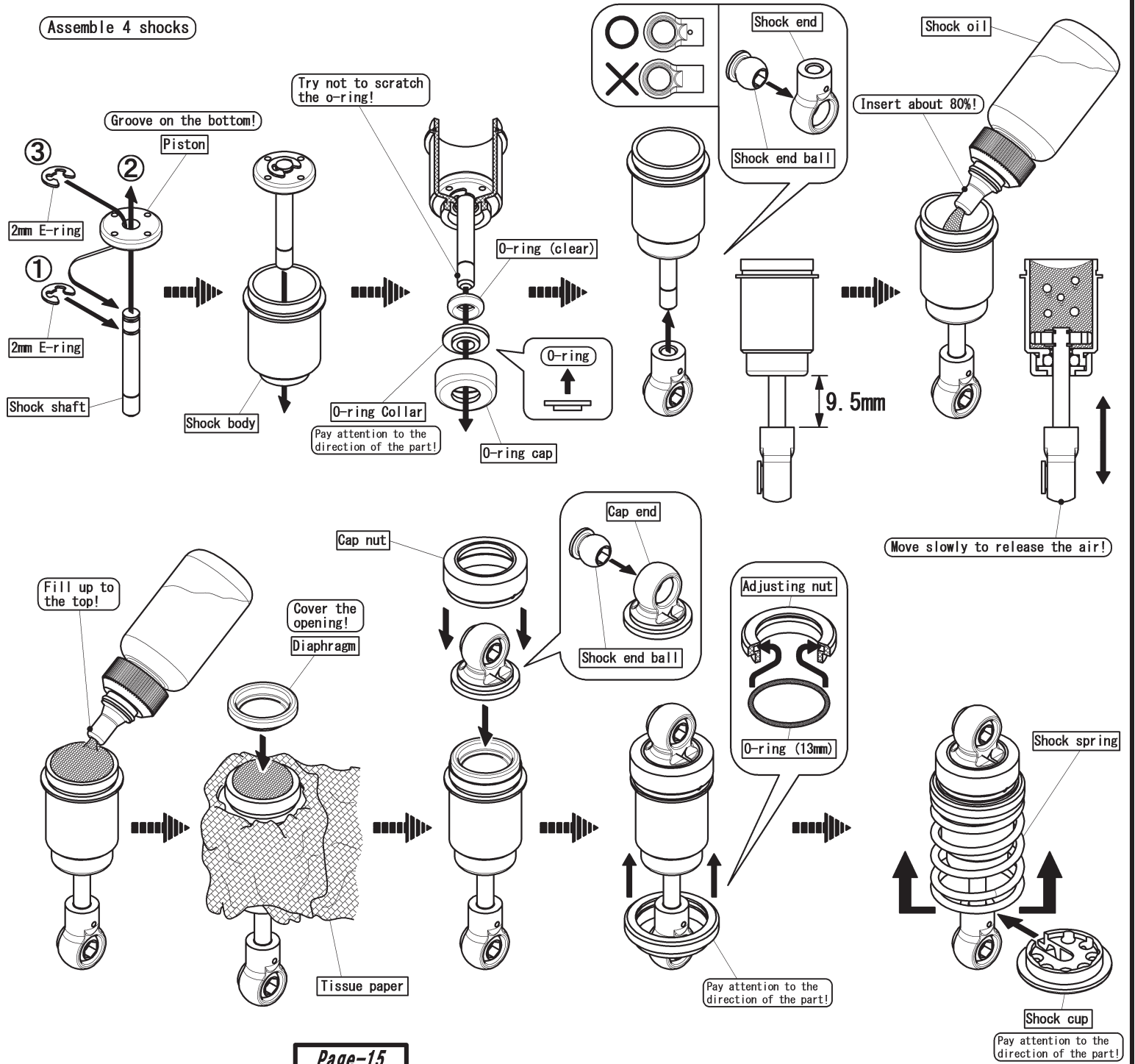



**Front Assembly**

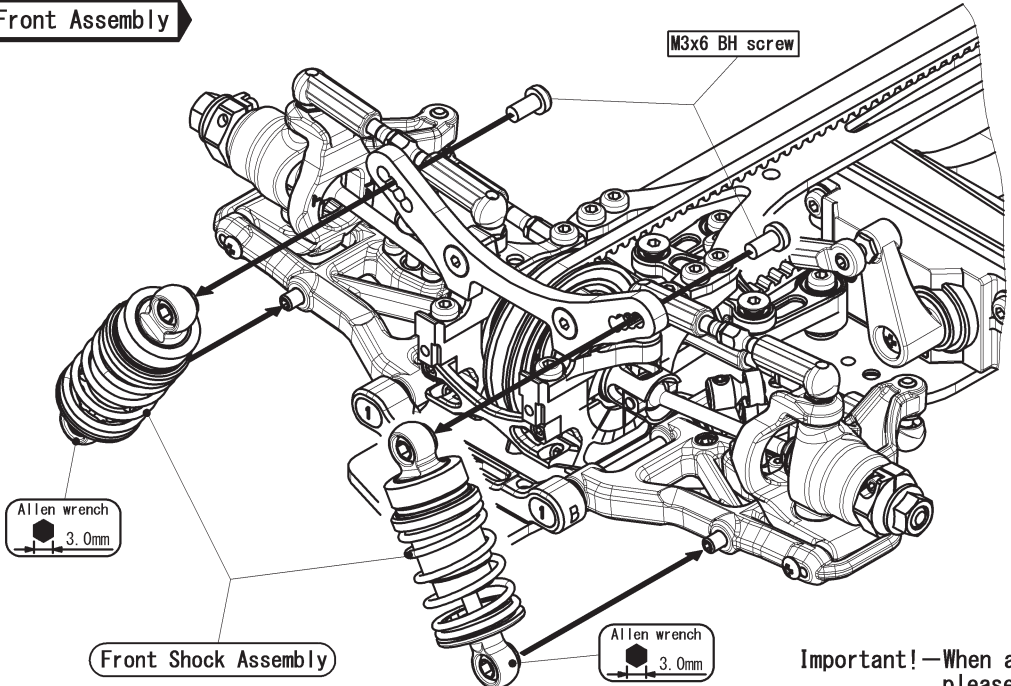



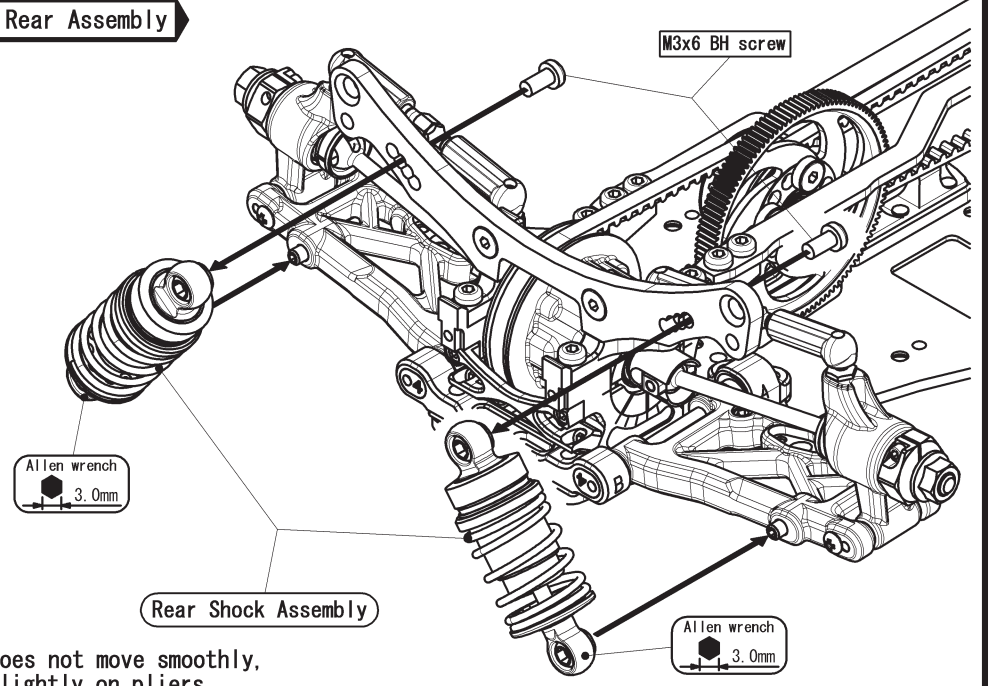

**Rear Assembly**



Important!—When a ball does not move smoothly, please crush lightly on pliers.

**[ Bag-14 Contents ]**

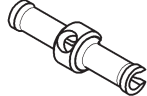
**[FRONT ANTI-ROLL BAR PARTS]**

-  --x2 2x5mm cap screw
  -  --x3 3x3mm set screw
  -  --x1 Stopper
  -  --x2 Anti-roll bar holder
- Thickness markings
- x1 Anti-roll bar (φ1.3) front
- ← φ 1.3

**Front Assembly**

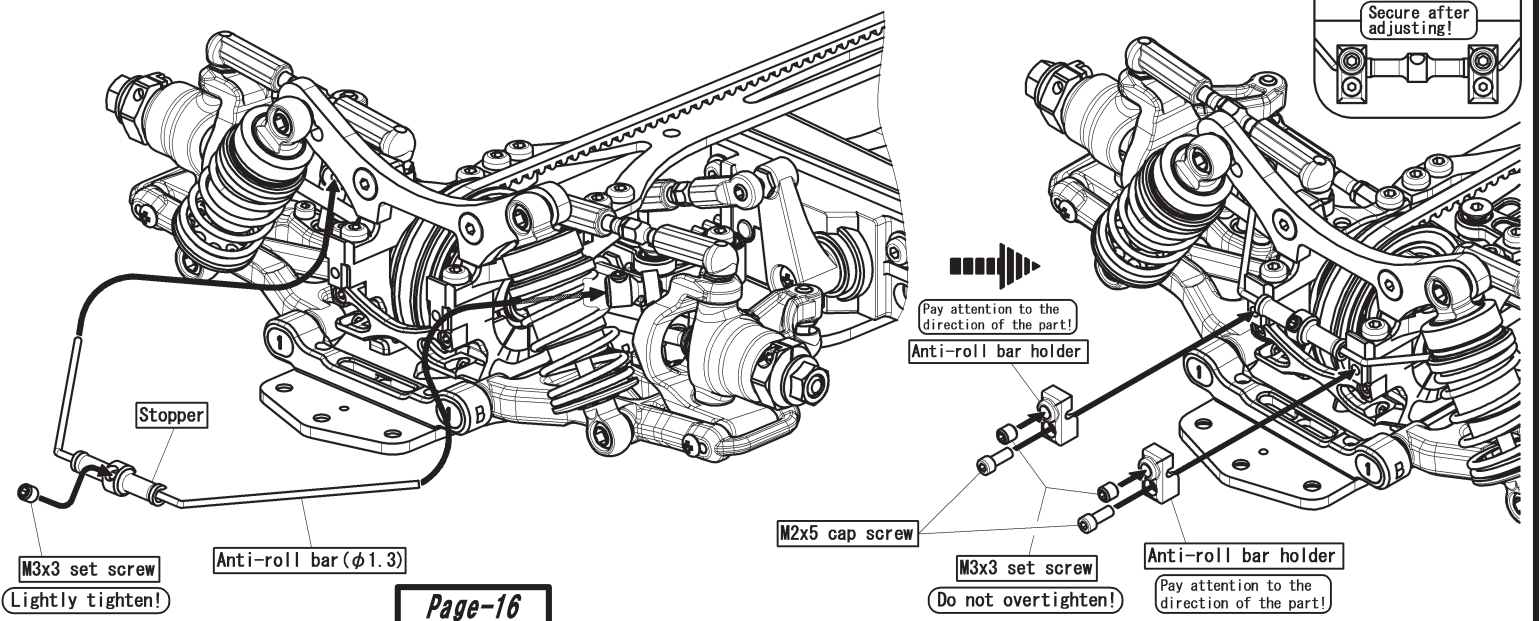



[ Bag-14 Contents ]

[REAR ANTI-ROLL BAR PARTS]

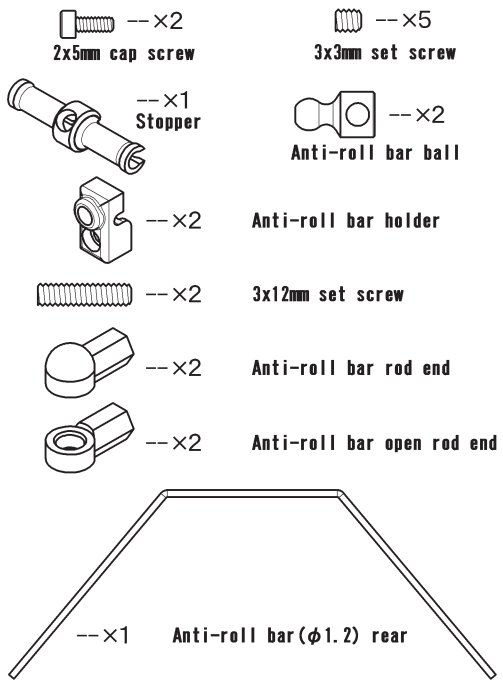

Rear Assembly

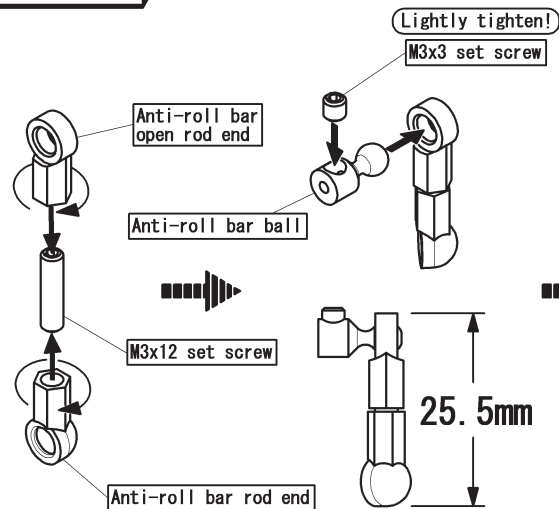

Assemble 2 sets

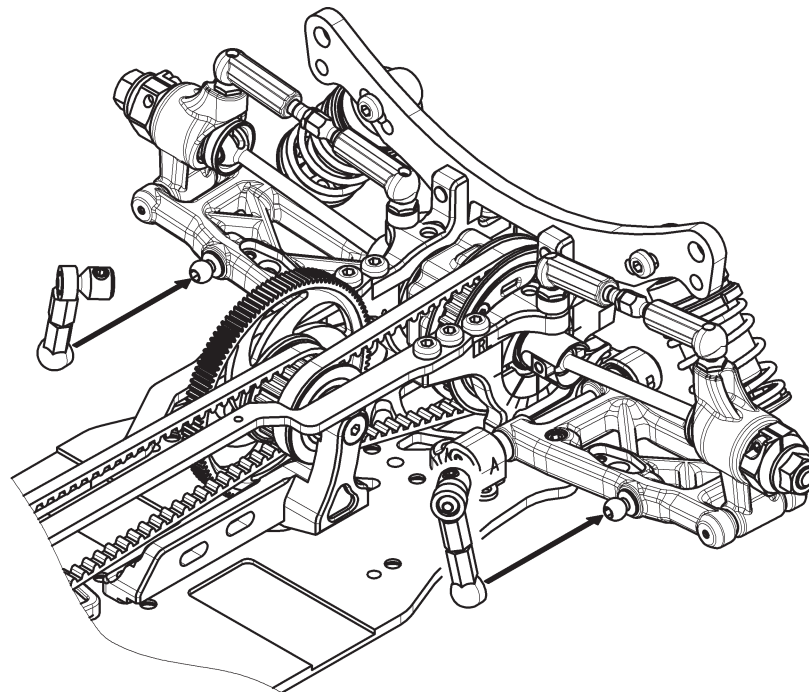

Insert the Anti-roll bar into the Anti-roll bar ball, secure the Anti-roll bar holder. Adjust the stoppers so that the bar is equal length on both sides. Tighten the 3x3mm holder set screws to eliminate play in the bar. Adjust the Anti-roll bar balls so that the Anti-roll bar rods are as close to being perpendicular to the bar as possible.

**Important!**—Overtightening the set screws used for the anti-roll bar holders may cause a bind in the movement of the anti-roll bar, affecting handling.

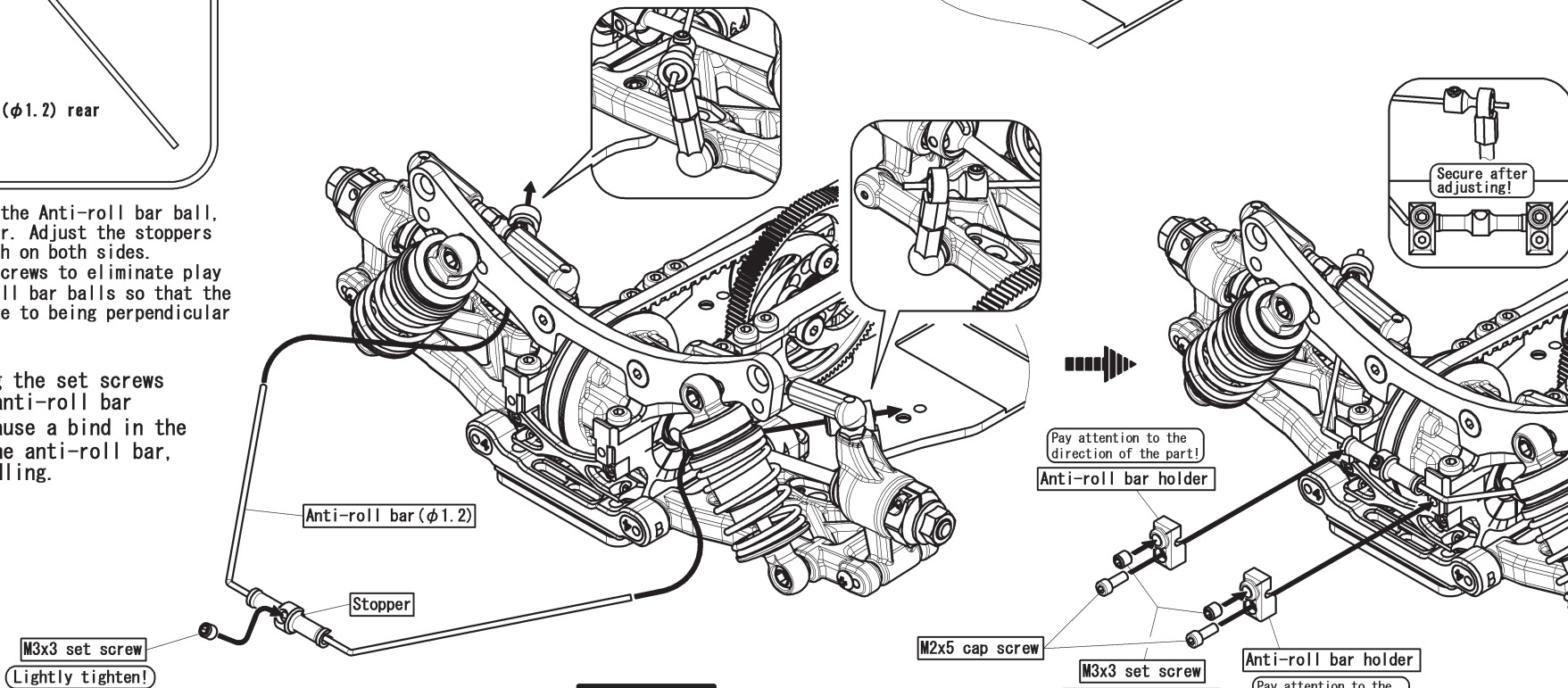

**[ Bag-15 Contents ]**

 --x7   
  --x2   
  --x2  
 3x8mm FH screw    3x15mm FH screw    3x6mm BH screw

 --x8   
  --x4  
 Body clips    Body mount

 --x2    Front body post

 --x2    Rear body post

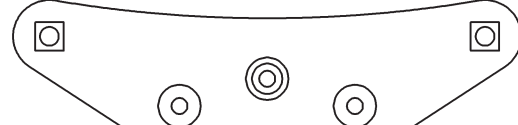
 --x1    Front bumper

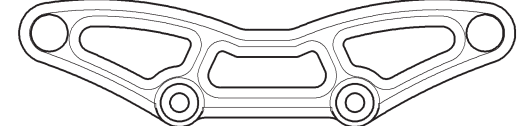
 --x1    Front bumper support

Also included: Double-sided tape x1

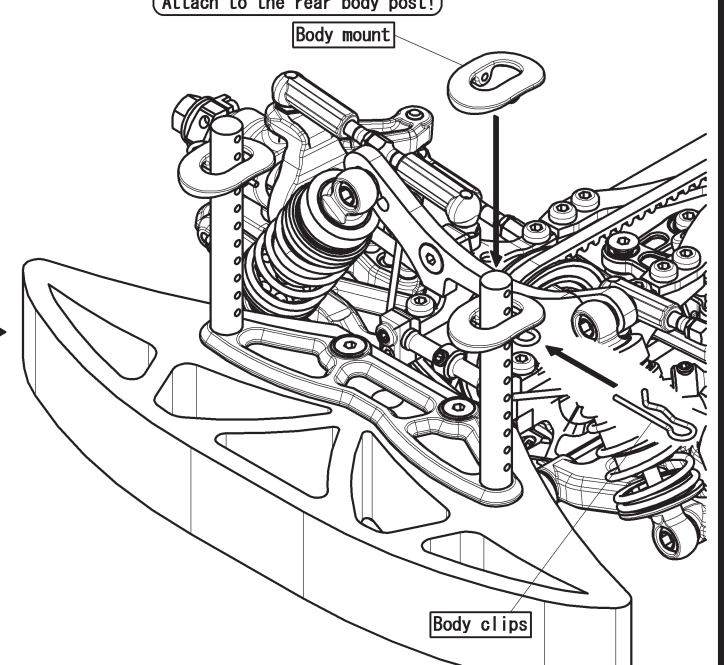
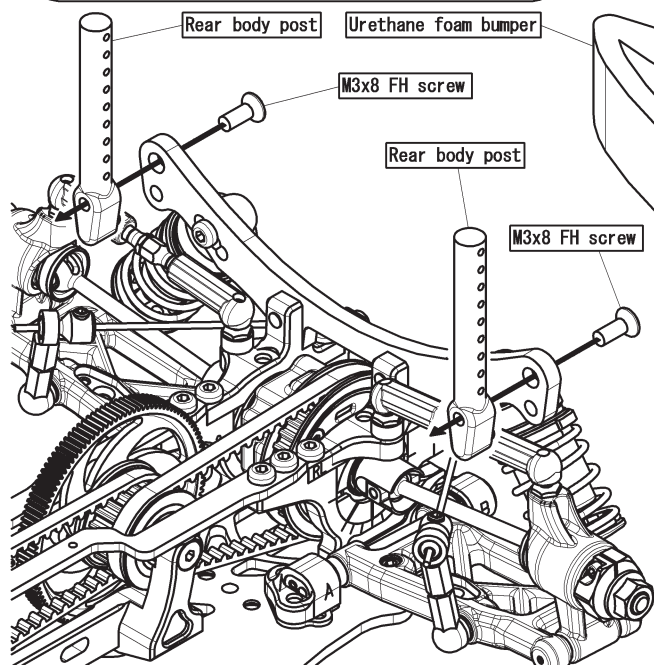
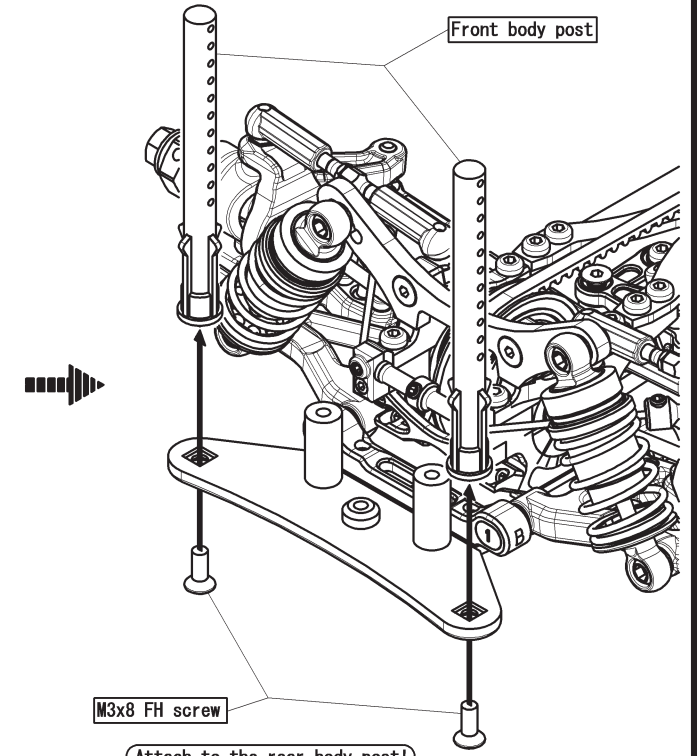
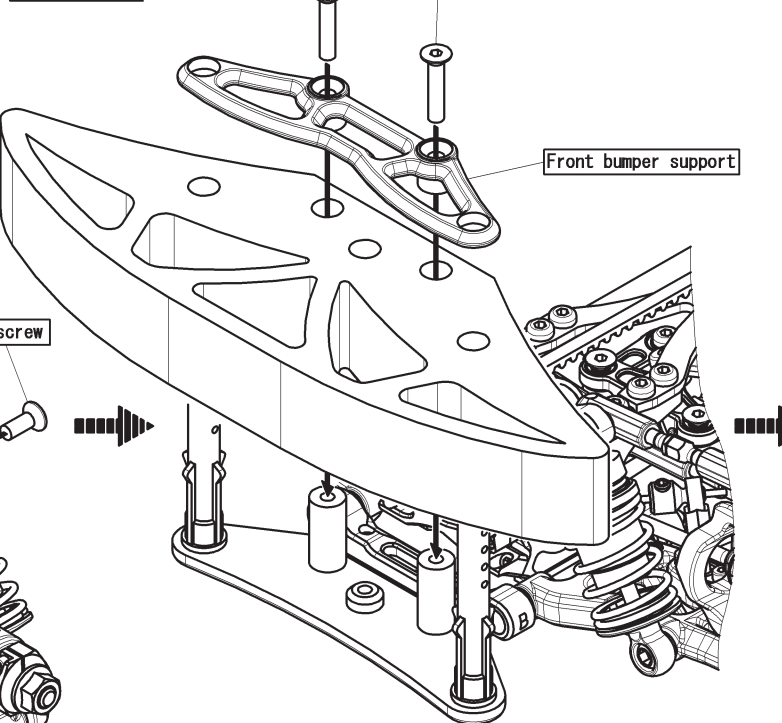
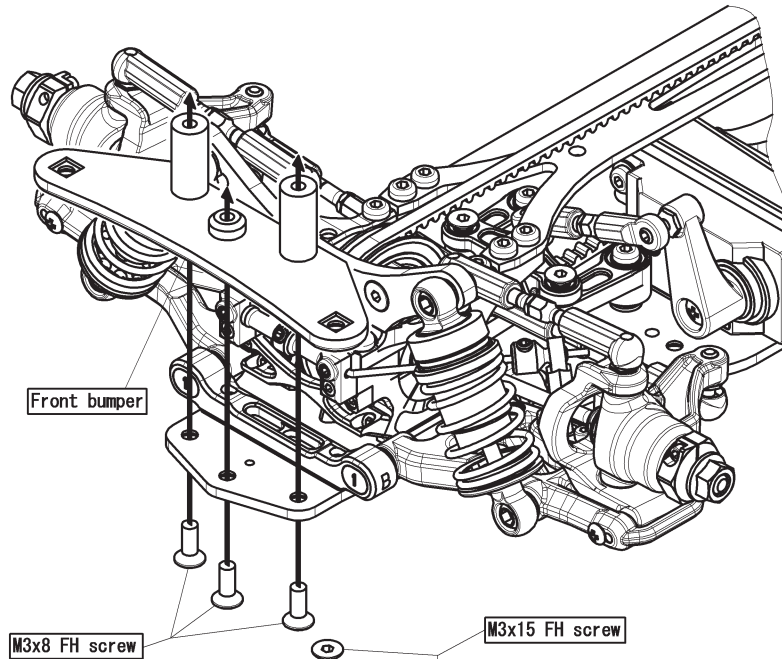



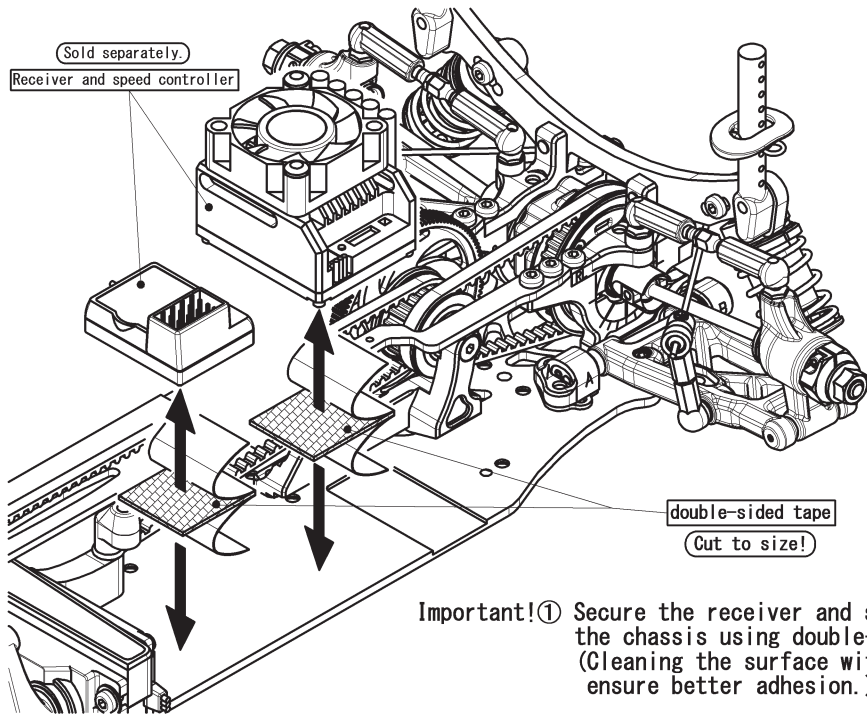

Important!① Secure the receiver and speed controller to the chassis using double-sided tape. (Cleaning the surface with motor spray will ensure better adhesion.)

Please cut the case where a tube is long.

Antenna tube

Slide the antenna wire through the bottom of the antenna mount and insert into the antenna tube. Leave about 1cm of wire at the top of the tube. Insert the antenna tube into the antenna mount.

Important!② Make sure to bundle any remaining antenna wire so that it does not interfere with the drivetrain.

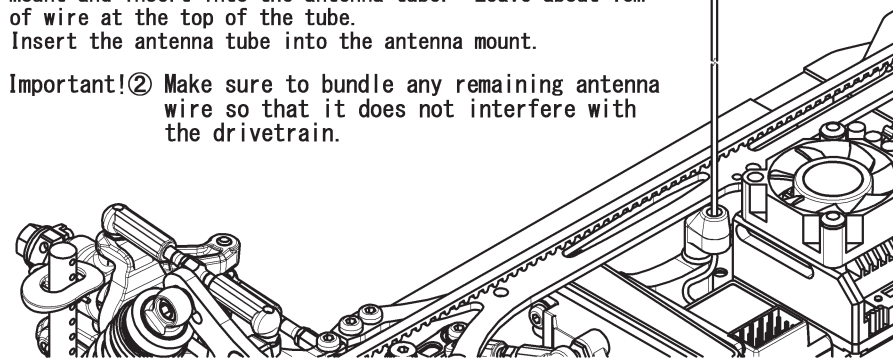

### Remaining parts from [ Bag-15 Contents ]

— ×2 3x6mm button head screw

Important!

- ③ Motor and pinion gear not included in kit. Please purchase separately.
- ④ Install the pinion so that the set screw is tightened onto the flat portion of the motor shaft.
- ⑤ Adjust the gear mesh to allow a very small gap between the teeth of the pinion and spur gear. (improper adjustment of the pinion and spur may result in damage to the gears.)
- ⑥ Continuous running of the motor will result in shorter motor life. Allow the motor to cool between runs.

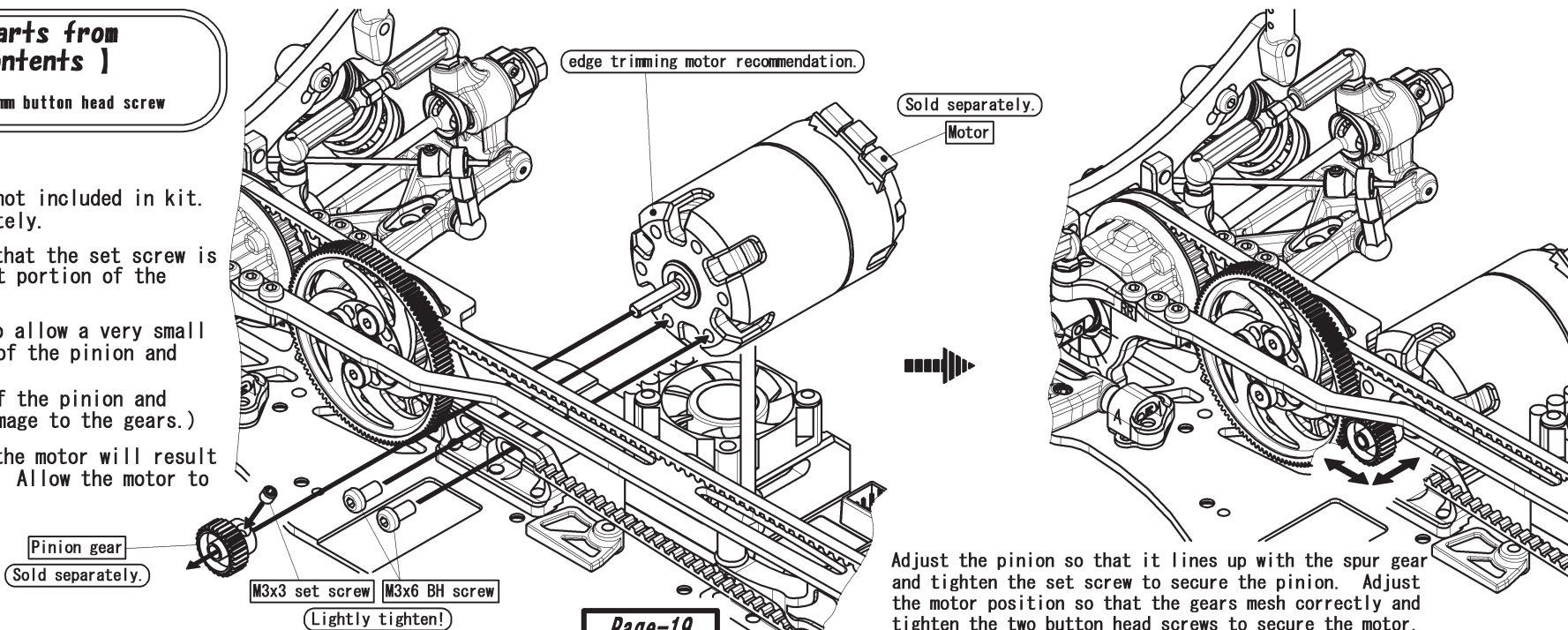



Adjust the pinion so that it lines up with the spur gear and tighten the set screw to secure the pinion. Adjust the motor position so that the gears mesh correctly and tighten the two button head screws to secure the motor.

**[ Bag-16 Contents ]**

 --x2 3x5mm flat head screw

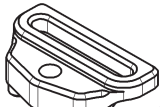
 --x2 3x6mm button head screw

 --x1 Battery holder

 --x1 Battery plate

 --x1 Battery plate base

Also included: Rubber sheet x1

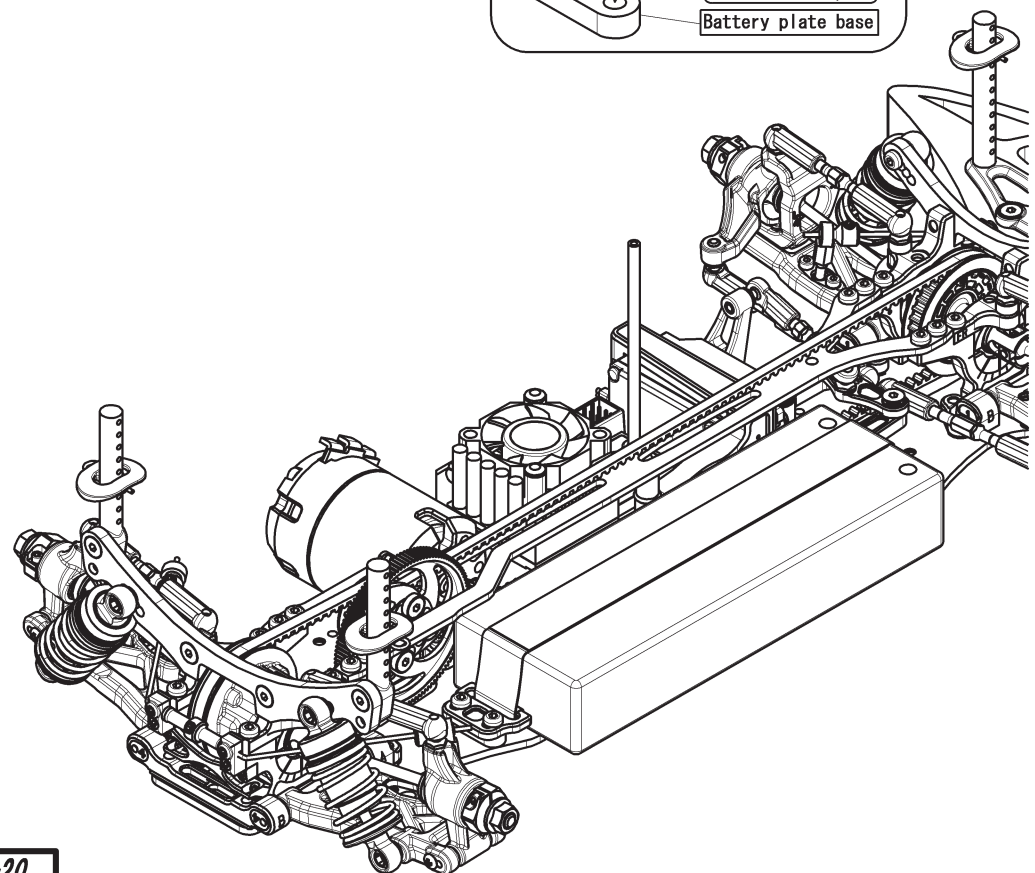
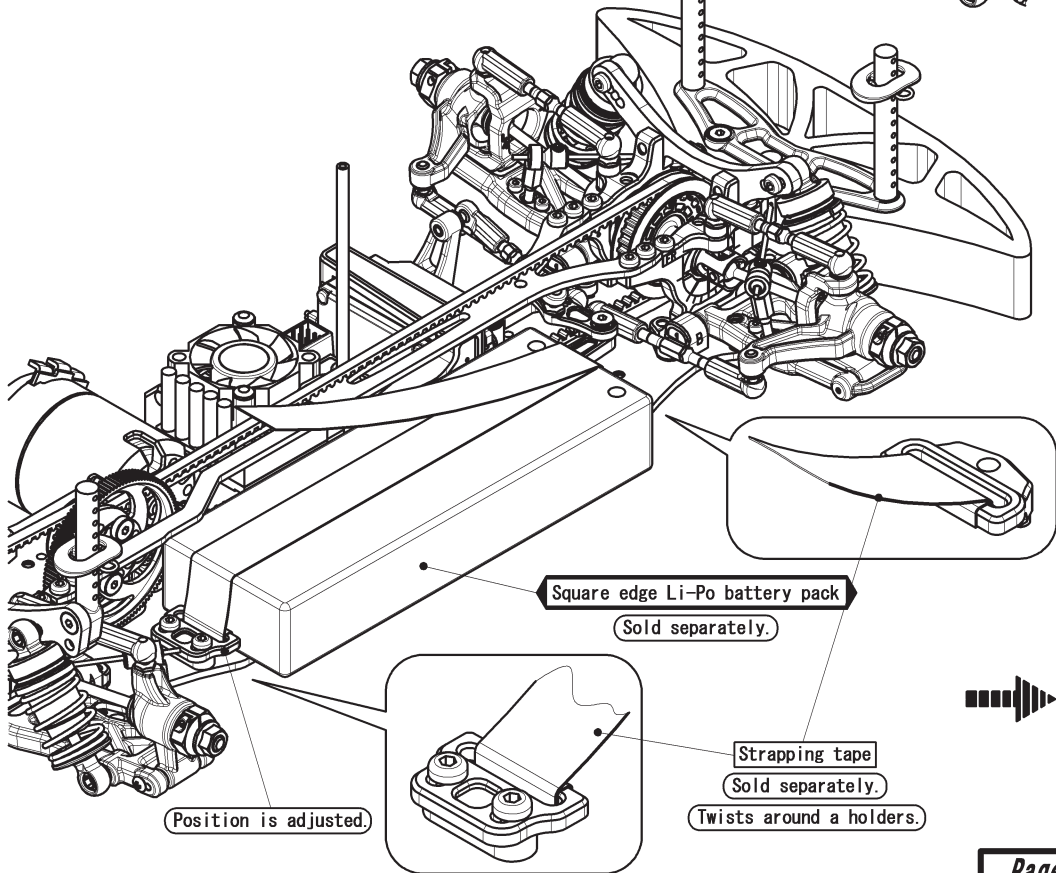
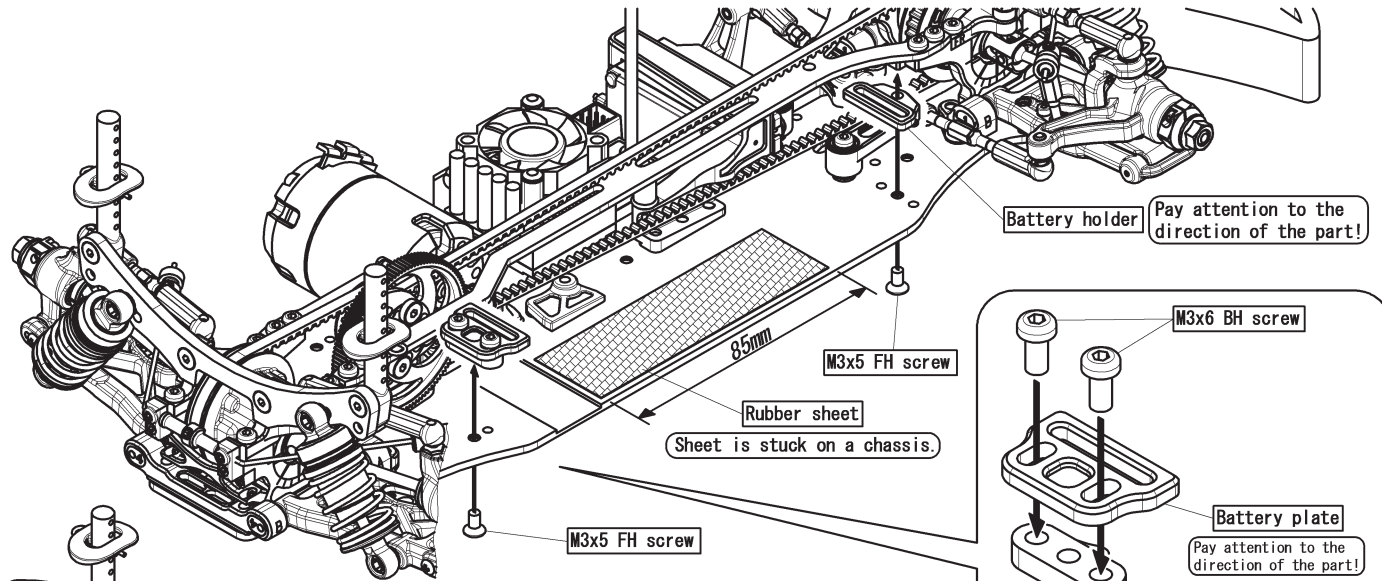



### Tire Assembly

Place the insert into the tire, and mount the tire onto the wheel.  
(Wheels and tires and inserts sold separately.)

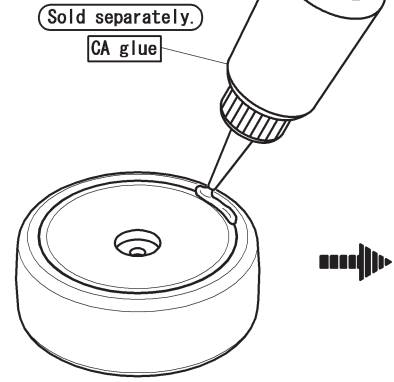
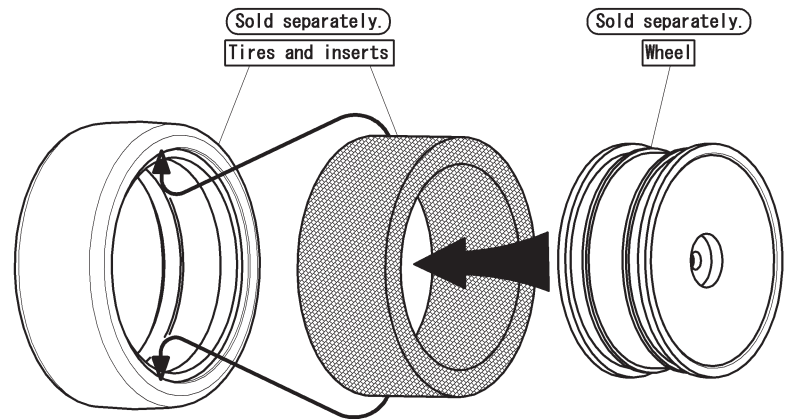

Pull the sidewall of the tire slightly away from the rim and apply CA (Cyanoacrylate) glue in between the tire bead and rim. Make sure that the bead settles onto the rim properly after each application. Slowly work your way around the tire. Allow glue to dry, then repeat on other side.

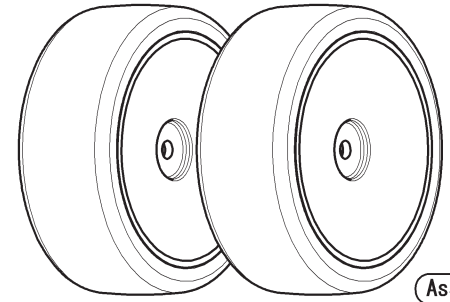









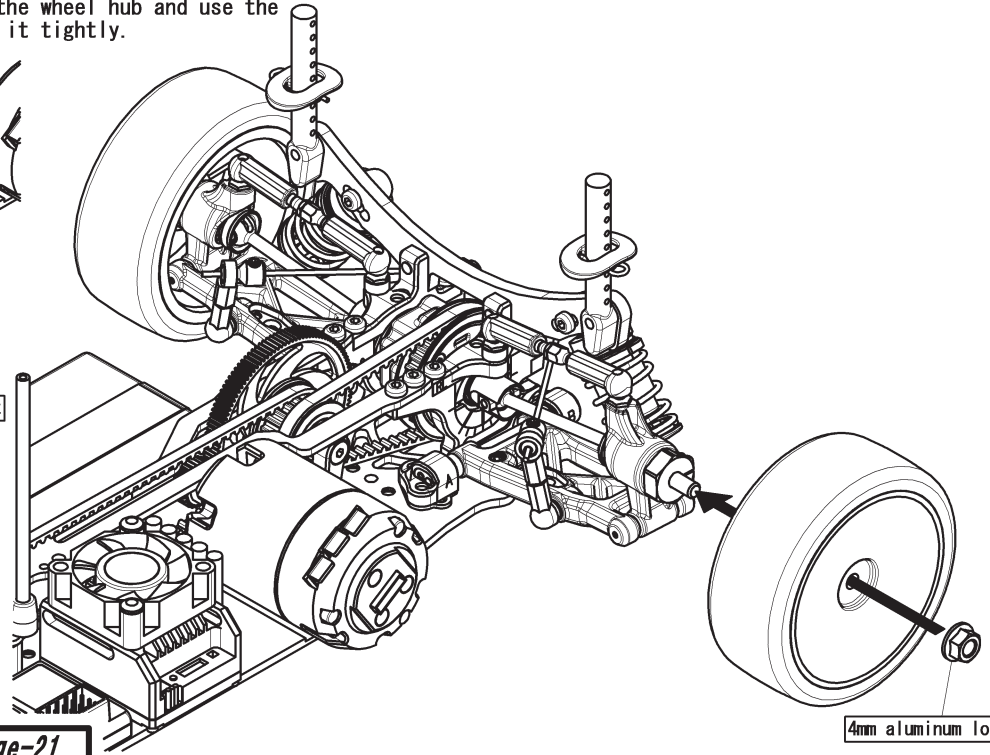
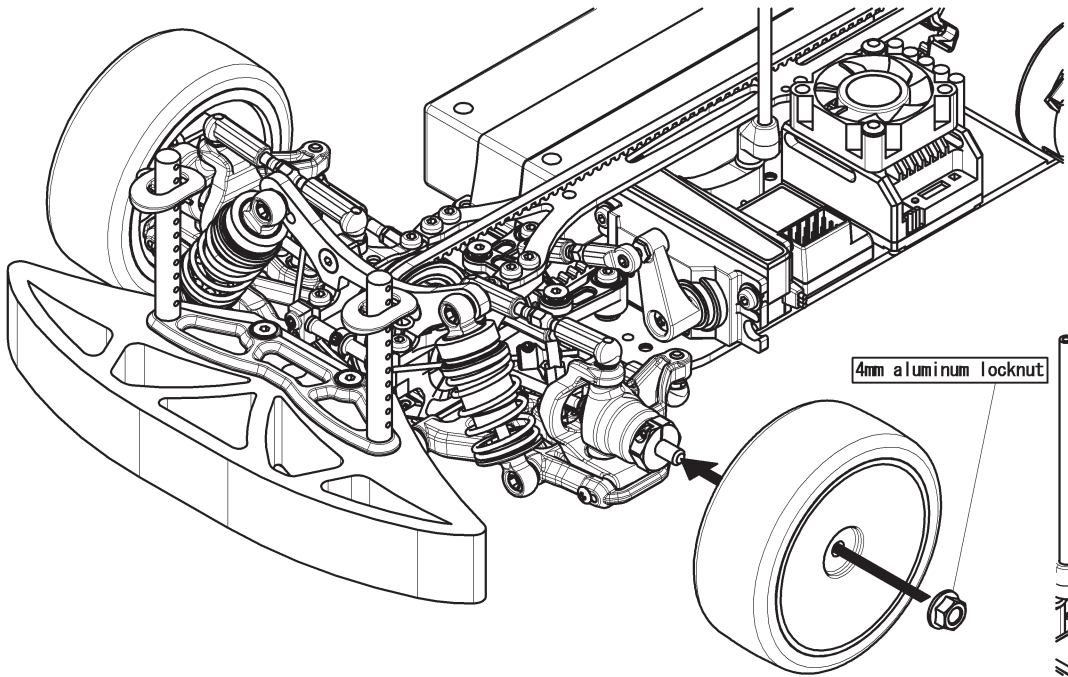

FRONT

**【 Repeat for the opposite side. 】**

Remove the previously installed 4mm locknut.  
Mount the wheel onto the wheel hub and use the 4mm locknut to secure it tightly.

REAR



	A	B	C
一体型 / Stick type	B8-301A	B8-301B	B8-301C
分割型 / Separate type	B8-301SA	B8-301SB	B8-301SC
FR型 / FR type	B8-301FRA	B8-301FRB	B8-301FRC
ブッシュの向き / Direction of Bushing			
	39.5mm	43.5mm	46.4mm
	39.9mm	43.9mm	46.8mm
	40.3mm	44.3mm	47.2mm
	40.7mm	44.7mm	47.6mm
	41.1mm	45.1mm	48.0mm
	41.5mm	45.5mm	48.4mm
	41.9mm	45.9mm	48.8mm
	42.3mm	46.3mm	49.2mm
	42.7mm	46.7mm	49.6mm

◆フロントト一脚 (単位：度) / Front Toe Angle (unit: degree)

		FF										C										
		A					B										C					
		42.3	42.7	43.5	43.9	44.3	44.7	45.1	45.5	45.9	46.3	46.7	46.4	46.8	47.2	47.6	48.0	48.4	48.8	49.2	49.6	
A	42.3	0	-0.3	-0.9	-1.2	-1.5	-1.8	-2.1	-2.3	-2.6	-2.9	-3.2	-3.0	-3.3	-3.6	-3.9	-4.2	-4.5	-4.8	-5.1	-5.3	
	42.7	-	0	-0.6	-0.9	-1.2	-1.5	-1.8	-2.1	-2.3	-2.6	-2.9	-2.7	-3.0	-3.3	-3.6	-3.9	-4.2	-4.5	-4.8	-5.1	
B	43.5	-	-	0	-0.3	-0.6	-0.9	-1.2	-1.5	-1.8	-2.1	-2.3	-2.1	-2.4	-2.7	-3.0	-3.3	-3.6	-3.9	-4.2	-4.5	
	43.9	-	-	-	0	-0.3	-0.6	-0.9	-1.2	-1.5	-1.8	-2.1	-2.1	-2.4	-2.7	-3.0	-3.3	-3.6	-3.9	-4.2	-4.5	
	44.3	-	-	-	-	0	-0.3	-0.6	-0.9	-1.2	-1.5	-1.8	-2.1	-2.4	-2.7	-3.0	-3.3	-3.6	-3.9	-4.2	-4.5	
	44.7	-	-	-	-	-	0	-0.3	-0.6	-0.9	-1.2	-1.5	-1.8	-2.1	-2.4	-2.7	-3.0	-3.3	-3.6	-3.9	-4.2	-4.5
	45.1	-	-	-	-	-	0	-0.3	-0.6	-0.9	-1.2	-1.5	-1.8	-2.1	-2.4	-2.7	-3.0	-3.3	-3.6	-3.9	-4.2	-4.5
	45.5	-	-	-	-	-	-	0	-0.3	-0.6	-0.9	-1.0	-1.2	-1.5	-1.8	-2.1	-2.4	-2.7	-3.0	-3.3	-3.6	-3.9
	45.9	-	-	-	-	-	-	-	0	-0.3	-0.6	-0.7	-1.0	-1.2	-1.5	-1.8	-2.1	-2.4	-2.7	-3.0	-3.3	-3.6
	46.3	-	-	-	-	-	-	-	-	0	-0.3	-0.6	-0.7	-1.0	-1.2	-1.5	-1.8	-2.1	-2.4	-2.7	-3.0	-3.3
	46.7	-	-	-	-	-	-	-	-	-	0	-0.3	-0.4	-0.7	-1.0	-1.2	-1.5	-1.8	-2.1	-2.4	-2.7	-3.0
	C	46.4	-	-	-	-	-	-	-	-	-	0	-0.3	-0.6	-0.9	-1.2	-1.5	-1.8	-2.1	-2.3	-2.6	-2.9
46.8		-	-	-	-	-	-	-	-	-	-	0	-0.3	-0.6	-0.9	-1.2	-1.5	-1.8	-2.1	-2.3	-2.6	
47.2		-	-	-	-	-	-	-	-	-	-	-	0	-0.3	-0.6	-0.9	-1.2	-1.5	-1.8	-2.1	-2.3	
47.6		-	-	-	-	-	-	-	-	-	-	-	-	0	-0.3	-0.6	-0.9	-1.2	-1.5	-1.8	-2.1	
48.0		-	-	-	-	-	-	-	-	-	-	-	-	-	0	-0.3	-0.6	-0.9	-1.2	-1.5	-1.8	
48.4		-	-	-	-	-	-	-	-	-	-	-	-	-	-	0	-0.3	-0.6	-0.9	-1.2	-1.5	
48.8		-	-	-	-	-	-	-	-	-	-	-	-	-	-	-	0	-0.3	-0.6	-0.9	-1.2	
49.2		-	-	-	-	-	-	-	-	-	-	-	-	-	-	-	-	-	-	0	-0.3	
49.6		-	-	-	-	-	-	-	-	-	-	-	-	-	-	-	-	-	-	-	0	

◆リアト一脚 (単位：度) / Rear Toe Angle (unit: degree)

		RF										C									
		A					B					C									
		40.3	40.7	41.1	41.5	41.9	42.3	42.7	43.5	43.9	44.3	44.7	45.1	45.5	45.9	46.3	46.7	46.4	46.8	47.2	47.6
RR	43.5	2.3	2.0	1.7	1.4	1.2	0.9	0.6	0	-	-	-	-	-	-	-	-	-	-	-	-
	43.9	2.6	2.3	2.0	1.7	1.4	1.2	0.9	0.3	0	-	-	-	-	-	-	-	-	-	-	-
	44.3	2.9	2.6	2.3	2.0	1.7	1.4	1.2	0.6	0.3	0	-	-	-	-	-	-	-	-	-	-
	44.7	3.2	2.9	2.6	2.3	2.0	1.7	1.4	0.9	0.6	0.3	0	-	-	-	-	-	-	-	-	-
	45.1	3.5	3.2	2.9	2.6	2.3	2.0	1.7	1.2	0.9	0.6	0.3	0	-	-	-	-	-	-	-	-
	45.5	3.7	3.5	3.2	2.9	2.6	2.3	2.0	1.4	1.2	0.9	0.6	0.3	0	-	-	-	-	-	-	-
	45.9	4.0	3.7	3.5	3.2	2.9	2.6	2.3	1.7	1.4	1.2	0.9	0.6	0.3	0	-	-	-	-	-	-
	46.3	4.3	4.0	3.7	3.5	3.2	2.9	2.6	2.0	1.7	1.4	1.2	0.9	0.6	0.3	0	-	-	-	-	-
	46.7	4.6	4.3	4.0	3.7	3.5	3.2	2.9	2.3	2.0	1.7	1.4	1.2	0.9	0.6	0.3	0	-	-	-	-
	46.4	4.4	4.1	3.8	3.5	3.2	2.9	2.7	2.1	1.8	1.5	1.2	0.9	0.6	0.4	0.1	-	0	-	-	-
C	46.8	4.7	4.4	4.1	3.8	3.5	3.2	2.9	2.4	2.1	1.8	1.5	1.2	0.9	0.6	0.4	0.1	0.3	0	-	-
	47.2	5.0	4.7	4.4	4.1	3.8	3.5	3.2	2.7	2.4	2.1	1.8	1.5	1.2	0.9	0.6	0.4	0.6	0.3	0	-
	47.6	5.2	5.0	4.7	4.4	4.1	3.8	3.5	2.9	2.7	2.4	2.1	1.8	1.5	1.2	0.9	0.6	0.9	0.6	0.3	0
	48.0	5.5	5.2	5.0	4.7	4.4	4.1	3.8	3.2	2.9	2.7	2.4	2.1	1.8	1.5	1.2	0.9	1.2	0.9	0.6	0.3
	48.4	5.8	5.5	5.2	5.0	4.7	4.4	4.1	3.5	3.2	2.9	2.7	2.4	2.1	1.8	1.5	1.2	1.4	1.2	0.9	0.6
	48.8	6.1	5.8	5.5	5.2	5.0	4.7	4.4	3.8	3.5	3.2	2.9	2.7	2.4	2.1	1.8	1.5	1.7	1.4	1.2	0.9
	49.2	6.4	6.1	5.8	5.5	5.2	5.0	4.7	4.1	3.8	3.5	3.2	2.9	2.7	2.4	2.1	1.8	2.0	1.7	1.4	1.2
	49.6	6.7	6.4	6.1	5.8	5.5	5.2	5.0	4.4	4.1	3.8	3.5	3.2	2.9	2.7	2.4	2.1	2.3	2.0	1.7	1.4



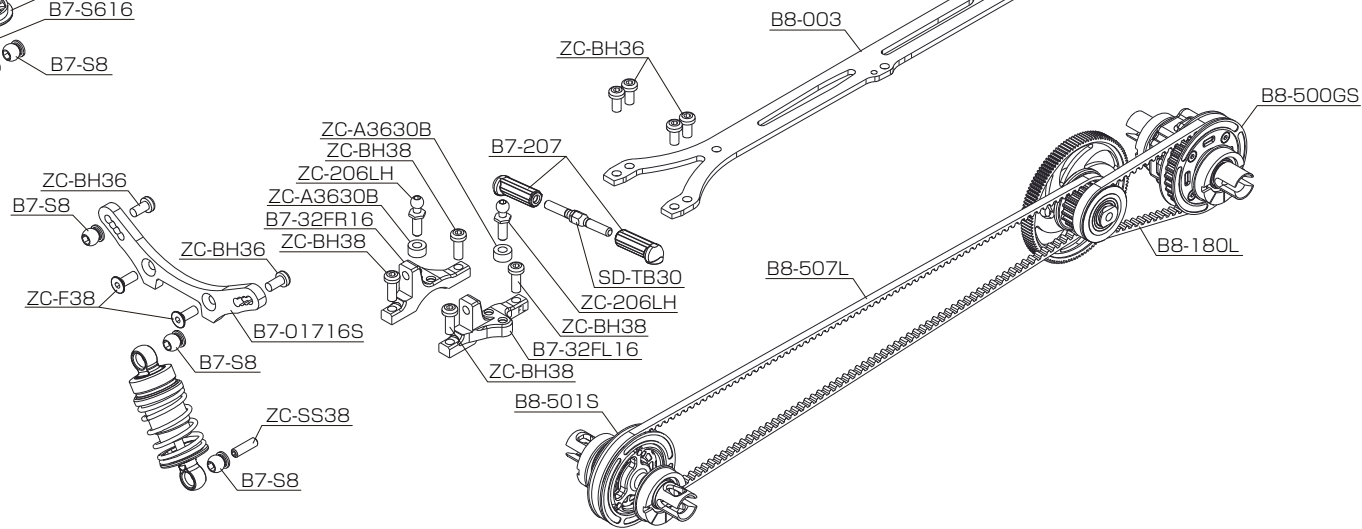
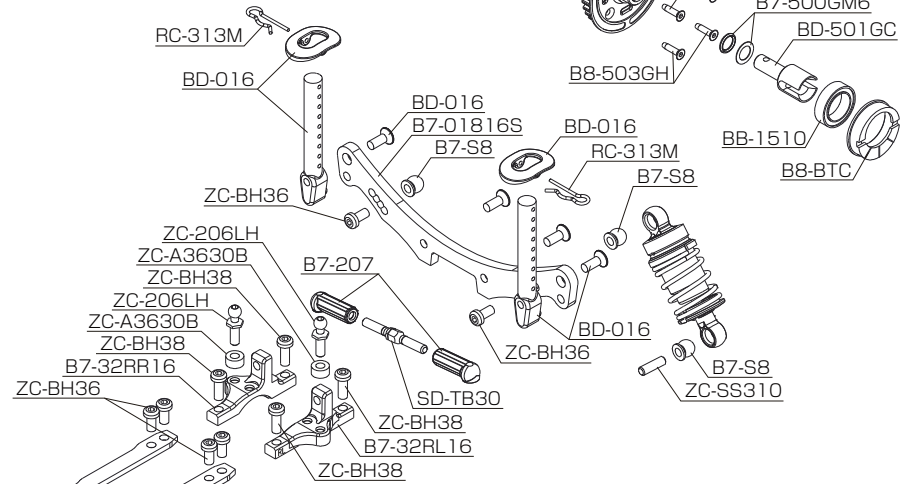
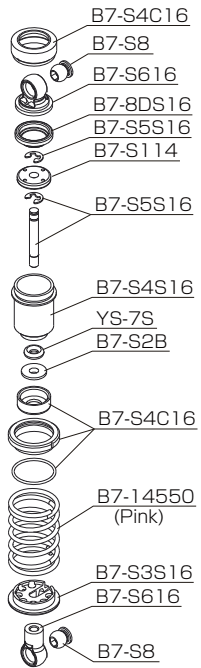
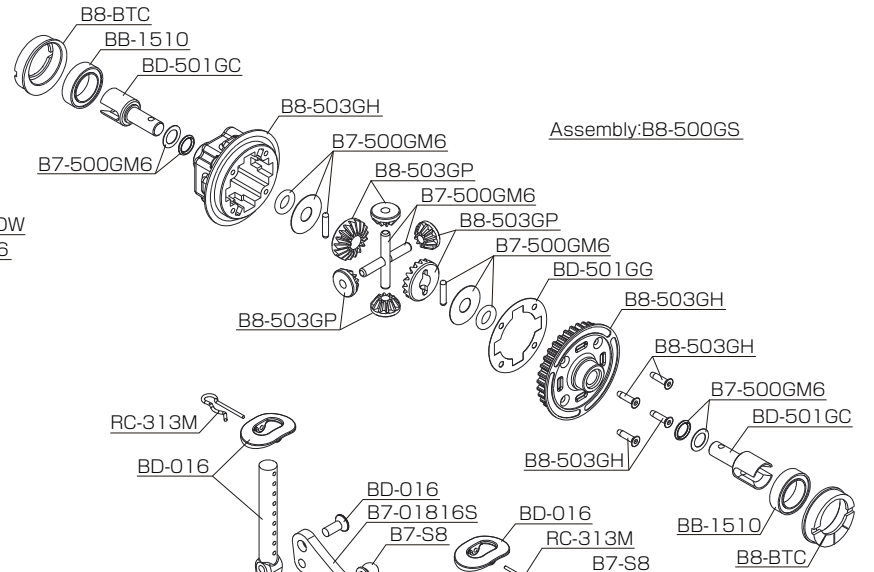
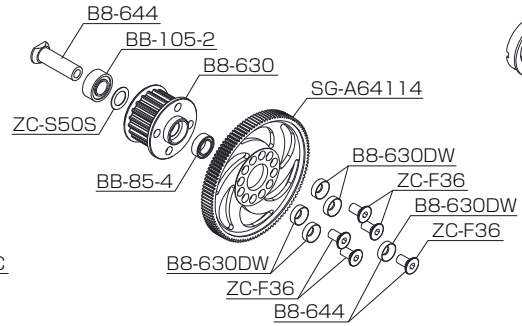
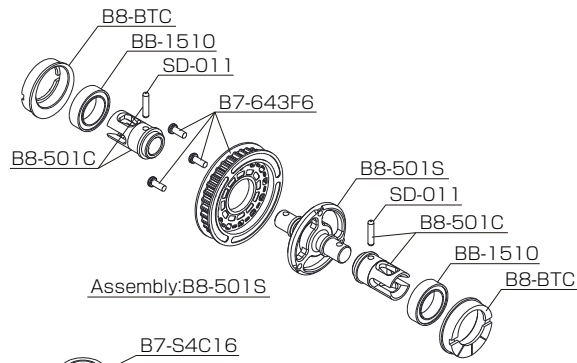



<BD8 GEAR RATIO (48pitch)>

2nd RATIO		SPUR GEAR														2nd RATIO	
1.700		74	75	76	77	78	79	80	81	82	83	84	85	86	87	1.700	
PINION GEAR	17	7.400	7.500	7.600	7.700	7.800	7.900	8.000	8.100	8.200	8.300	8.400	8.500	8.600	8.700	17	PINION GEAR
	18	6.989	7.083	7.178	7.272	7.367	7.461	7.556	7.650	7.744	7.839	7.933	8.028	8.122	8.217	18	
	19	6.621	6.711	6.800	6.889	6.979	7.068	7.158	7.247	7.337	7.426	7.516	7.605	7.695	7.784	19	
	20	6.290	6.375	6.460	6.545	6.630	6.715	6.800	6.885	6.970	7.055	7.140	7.225	7.310	7.395	20	
	21	5.990	6.071	6.152	6.233	6.314	6.395	6.476	6.557	6.638	6.719	6.800	6.881	6.962	7.043	21	
	22	5.718	5.795	5.873	5.950	6.027	6.105	6.182	6.259	6.336	6.414	6.491	6.568	6.645	6.723	22	
	23	5.470	5.543	5.617	5.691	5.765	5.839	5.913	5.987	6.061	6.135	6.209	6.283	6.357	6.430	23	
	24	5.242	5.313	5.383	5.454	5.525	5.596	5.667	5.738	5.808	5.879	5.950	6.021	6.092	6.163	24	
	25	5.032	5.100	5.168	5.236	5.304	5.372	5.440	5.508	5.576	5.644	5.712	5.780	5.848	5.916	25	
	26	4.838	4.904	4.969	5.035	5.100	5.165	5.231	5.296	5.362	5.427	5.492	5.558	5.623	5.688	26	
	27	4.659	4.722	4.785	4.848	4.911	4.974	5.037	5.100	5.163	5.226	5.289	5.352	5.415	5.478	27	
	28	4.493	4.554	4.614	4.675	4.736	4.796	4.857	4.918	4.979	5.039	5.100	5.161	5.221	5.282	28	
	29	4.338	4.397	4.455	4.514	4.572	4.631	4.690	4.748	4.807	4.866	4.924	4.983	5.041	5.100	29	
	30	4.193	4.250	4.307	4.363	4.420	4.477	4.533	4.590	4.647	4.703	4.760	4.817	4.873	4.930	30	
31	4.058	4.113	4.168	4.223	4.277	4.332	4.387	4.442	4.497	4.552	4.606	4.661	4.716	4.771	31		
		74	75	76	77	78	79	80	81	82	83	84	85	86	87		
		SPUR GEAR															

※使用するモーターの形状によっては、アッパーデッキと干渉して上記ギヤ比が使えない場合がありますのでご注意下さい。



<BD8 GEAR RATIO (64pitch)>

2nd RATIO		SPUR GEAR																	2nd RATIO		
1.700		99	100	101	102	103	104	105	106	107	108	109	110	111	112	113	114	115	116	1.700	
PINION GEAR	23	7.317	7.391	7.465	7.539	7.613	7.687	7.761	7.835	7.909	7.983	8.057	8.130	8.204	8.278	8.352	8.426	8.500	8.574	23	PINION GEAR
	24	7.013	7.083	7.154	7.225	7.296	7.367	7.438	7.508	7.579	7.650	7.721	7.792	7.863	7.933	8.004	8.075	8.146	8.217	24	
	25	6.732	6.800	6.868	6.936	7.004	7.072	7.140	7.208	7.276	7.344	7.412	7.480	7.548	7.616	7.684	7.752	7.820	7.888	25	
	26	6.473	6.538	6.604	6.669	6.735	6.800	6.865	6.931	6.996	7.062	7.127	7.192	7.258	7.323	7.388	7.454	7.519	7.585	26	
	27	6.233	6.296	6.359	6.422	6.485	6.548	6.611	6.674	6.737	6.800	6.863	6.926	6.989	7.052	7.115	7.178	7.241	7.304	27	
	28	6.011	6.071	6.132	6.193	6.254	6.314	6.375	6.436	6.496	6.557	6.618	6.679	6.739	6.800	6.861	6.921	6.982	7.043	28	
	29	5.803	5.862	5.921	5.979	6.038	6.097	6.155	6.214	6.272	6.331	6.390	6.448	6.507	6.566	6.624	6.683	6.741	6.800	29	
	30	5.610	5.667	5.723	5.780	5.837	5.893	5.950	6.007	6.063	6.120	6.177	6.233	6.290	6.347	6.403	6.460	6.517	6.573	30	
	31	5.429	5.484	5.539	5.594	5.648	5.703	5.758	5.813	5.868	5.923	5.977	6.032	6.087	6.142	6.197	6.252	6.306	6.361	31	
	32	5.259	5.313	5.366	5.419	5.472	5.525	5.578	5.631	5.684	5.738	5.791	5.844	5.897	5.950	6.003	6.056	6.109	6.163	32	
	33	5.100	5.152	5.203	5.255	5.306	5.358	5.409	5.461	5.512	5.564	5.615	5.667	5.718	5.770	5.821	5.873	5.924	5.976	33	
	34	4.950	5.000	5.050	5.100	5.150	5.200	5.250	5.300	5.350	5.400	5.450	5.500	5.550	5.600	5.650	5.700	5.750	5.800	34	
	35	4.809	4.857	4.906	4.954	5.003	5.051	5.100	5.149	5.197	5.246	5.294	5.343	5.391	5.440	5.489	5.537	5.586	5.634	35	
	36	4.675	4.722	4.769	4.817	4.864	4.911	4.958	5.006	5.053	5.100	5.147	5.194	5.242	5.289	5.336	5.383	5.431	5.478	36	
	37	4.549	4.595	4.641	4.686	4.732	4.778	4.824	4.870	4.916	4.962	5.008	5.054	5.100	5.146	5.192	5.238	5.284	5.330	37	
	38	4.429	4.474	4.518	4.563	4.608	4.653	4.697	4.742	4.787	4.832	4.876	4.921	4.966	5.011	5.055	5.100	5.145	5.189	38	
	39	4.315	4.359	4.403	4.446	4.490	4.533	4.577	4.621	4.664	4.708	4.751	4.795	4.838	4.882	4.926	4.969	5.013	5.056	39	
	40	4.208	4.250	4.293	4.335	4.378	4.420	4.463	4.505	4.548	4.590	4.633	4.675	4.718	4.760	4.803	4.845	4.888	4.930	40	
41	4.105	4.146	4.188	4.229	4.271	4.312	4.354	4.395	4.437	4.478	4.520	4.561	4.602	4.644	4.685	4.727	4.768	4.810	41		
42	4.007	4.048	4.088	4.129	4.169	4.210	4.250	4.290	4.331	4.371	4.412	4.452	4.493	4.533	4.574	4.614	4.655	4.695	42		
		99	100	101	102	103	104	105	106	107	108	109	110	111	112	113	114	115	116		
		SPUR GEAR																			

※使用するモーターの形状によっては、アッパーデッキと干渉して上記ギヤ比が使えない場合がありますのでご注意下さい。











AS A MANUFACTURER OF WORLD CHAMPIONSHIP WINNING CARS,  
YOKOMO WILL CONTINUE TO PROVIDE THE BEST AVAILABLE TECHNOLOGY TO R/C ENTHUSIASTS ALL OVER THE WORLD.  
ENJOY THIS PRODUCT KNOWING THAT YOU ARE DRIVING ONE OF THE BEST HANDLING R/C CARS EVER DESIGNED.

RC MODEL CARS  
**YOKOMO**  
[www.teamyokomo.com](http://www.teamyokomo.com)

#### 世界のブランド YOKOMO

ヨコモは競技用 R/C カー（ラジオコントロールカー）の専門メーカーです。その製品は、全日本選手権、全米選手権、ヨーロッパ選手権、そして R/C カーレースの最高峰である世界選手権レースでも優勝。世界の R/C カーマニアに愛用されています。