

Assembly Manual

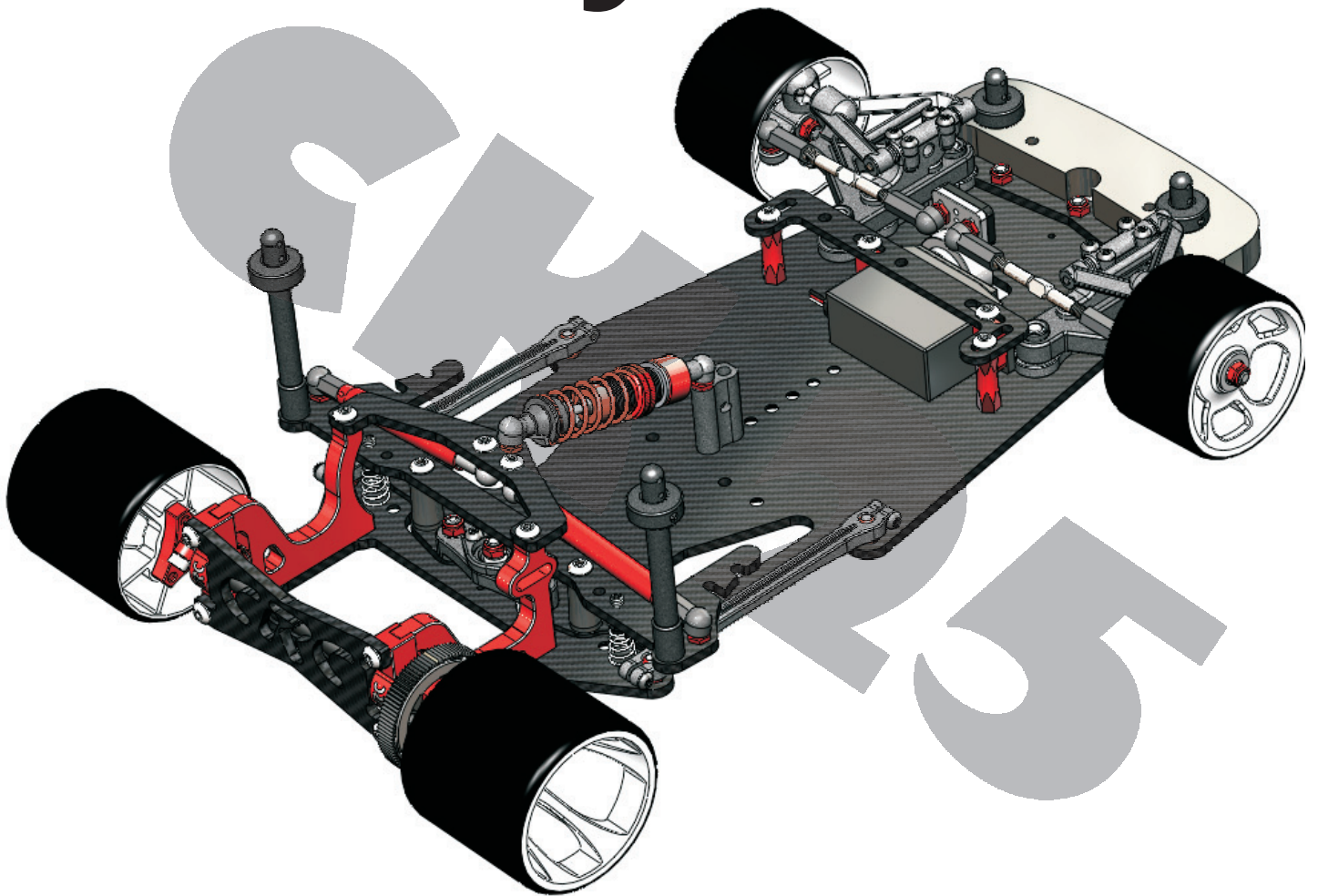

Carpet Knife™ 25

1/12th scale road race car kit

CALANDRA RACING CONCEPTS

CRC

World Champions

6785 Martin Street ~ Rome, NY 13440
Tel + Fax 315-338-0867 ~ www.teamcrc.com

Calandra Racing Concepts

CRC

World Champions

Thank you for choosing another fine Calandra Racing Concepts 1/12th scale road racing machine, the CK25. We are excited to mark our 25th year in the R/C model car racing industry. Yes, 25 years of making products, meeting people, enjoying this great hobby and of course, racing. We have met many racers and have won countless Regional, National and World Championships in all these years. This new release, the Carpet Knife 25 or "CK25" marks a great milestone within the organization, 25 years. Our first car released was the original Carpet Knife™ and now with 25 years of company history, we bring you the CK25.

Looking back...we have built the company by going to races large and small, meeting racers all over the world. Getting in the pits, rubbing elbows with hobbyists, racers and our customers. When CRC started, the internet didn't exist. Setups and product information was passed along by magazines and word of mouth at R/C race events across the country. CRC was there then and is there now supporting our customers and enjoying the hobby..

All of us at CRC are devoted to bringing you top performing products at a great price and value. All CRC staff members take part in the design, building, racing and maintaining CRC products daily. We know exactly how the product works and performs in the racing environment as we all enjoy this great hobby just like you.

This assembly manual supplies all the information and guidance you need to build the World Champion heritage Carpet Knife 25. Please read through the manual to get familiar with the steps needed to build your next Championship winning machine.

Center Pivot

Bag 1

3374 - Center Pivot Socket

40194 - Hard Anodized Alum Pivot ball

3254 - 2-56 Button Head

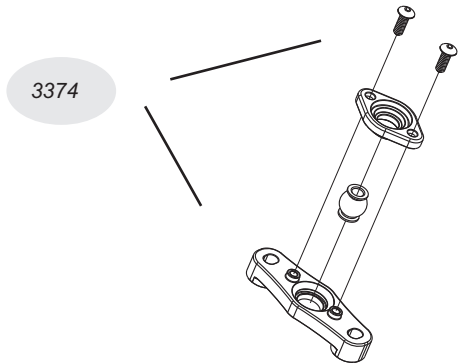

Note - Sometimes it is helpful to **slightly over-tighten the top clamp screws, then work the ball around by hand, and then loosen the screws so the ball floats around very free but without up-down play. Do not over-tighten the screws too much or you could warp the pivot socket.*

Center Pivot

Bag 1

33572 - CK25 Chassis Plate

33573 - CK25 Chassis Plate "Z-Flex stiff" Optional

1430 - 1/2" x 4-40 FH Allen-SS

12772 - 4-40 Thin Hex Nut

1209 - Washer

1412 - Red Locknut

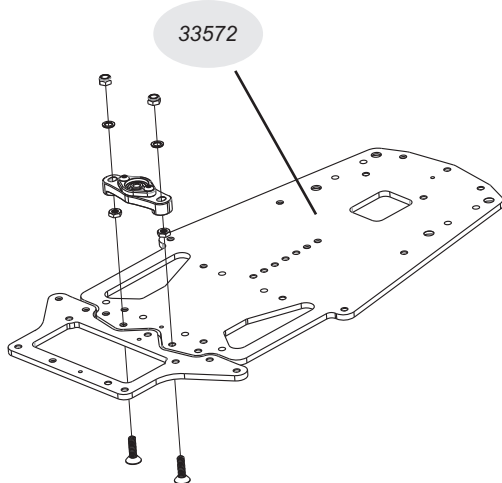

**Note - Leave the top lock-nuts loose for now. These will be securely tightened when setting the one-piece links in the following steps.*

Bag 2

1426 - 4-40 x
5/16" Flat Head



13615 -
Red Low-
Profile Ball



1412 - Red Locknut



1430 - 4-40 x 1/2"
Flat Head

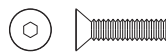

3254 - 2-56 Button Head



3281 - One-Piece
Side Links

3366 - Graphite
Bottom Plate

3366- Rear Bottom Plate-CK25

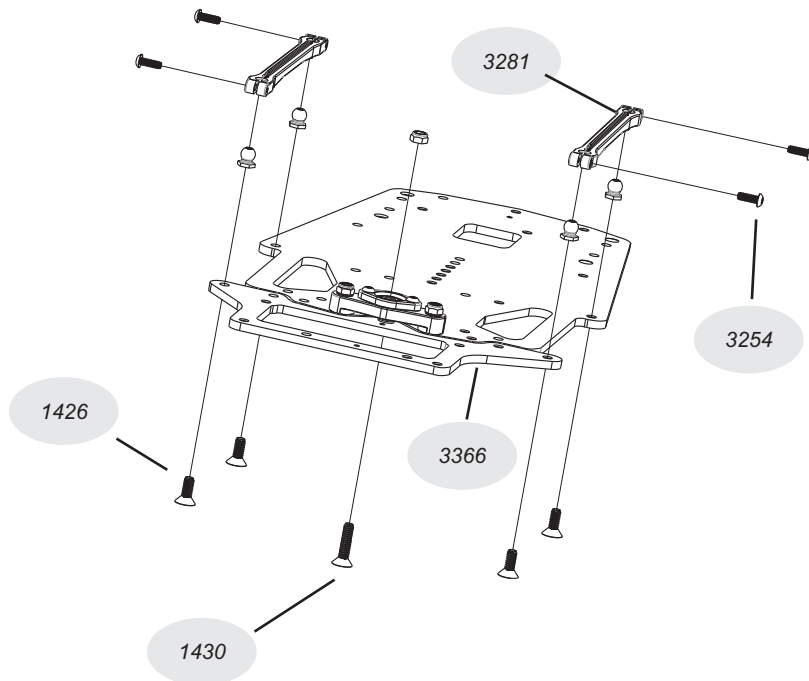

**NOTE - Before installing, inspect the side links and you will notice that the screw holes on one side of the link are larger than the holes on the other side. Before popping the links on the balls, be sure that the larger hole faces toward the outside of the chassis.*

Slide the 2-56 button head screws through the large holes in the outside of the side links, and then thread them into the small inner holes as shown in the illustration. Do not tighten these screws down all the way. Put just enough tension on them so that there is no play in the links, but so they pivot freely on the balls. The car will NOT handle properly if the links are too tight on the balls!

Setting the One-piece links

1 - Be sure the 2 aluminum locknuts on top of the center pivot are slightly loose. There should be a washer under each alum locknut. Notice that the center pivot "floats" or moves slightly on the 2 screws. This "floating" allows the links to "free up". This ensures that the rear pod plate pivots freely on the links and center pivot ball. This is a crucial step when setting up the car.

2 - Snap the 2 links on the balls (done in previous step). They should rock freely on the pivot balls.

3 - Place the chassis / rear bottom plate assembly on a flat surface. No tires and no diff on the car! A smooth table or desk should do. Be sure that the rear bottom plate and chassis are in a straight line, flat against the table, again, no tires on the car. Lightly "tap" the chassis and rear pod releasing any tension in the links. Keep the chassis flat on the table for step 4.

4 - Hold the chassis at the hold point "H" (not the rear pod) by pressing the chassis down to the table. Slowly tighten the 2 locknuts that secure the center pivot assembly. For now, just lightly snug one side, then the other.

5 - Pick up the car and check the pivoting action of rear lower plate. Rotate the rear plate from side-to-side. It should move free without binding or "clicking". If it does not, loosen the pivot locknuts and repeat steps 3+4.

If it rotates smoothly, tighten the locknuts on the center pivot more securely. Do this by again holding the chassis down to the table at the hold point "H". Slowly and carefully, fully tighten the locknuts that hold the center pivot assembly to the chassis. Do NOT hold the car by the rear pod and then tighten the locknuts, this will cause the rear pod to shift and bind instead of rotating freely. Top performance and handling of the car hinges (pun intended!) on the free movement of this rear plate. Be sure that the rear links and rear plate are free and not binding.

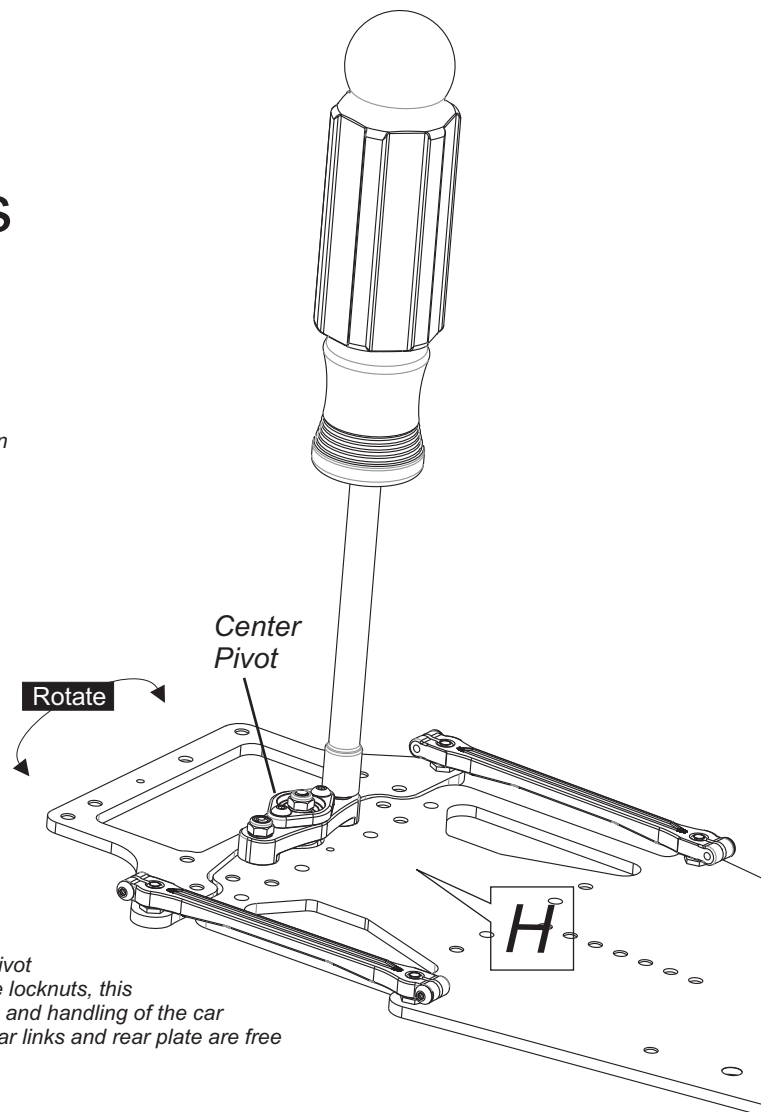

LCG Slider Pod

Bag 3

- 33501 - LCG Motor Plate
- 33511 - LCG Slider Bearing Carrier
- 33521 - LCG Left Side Pod Plate
- 33503- LCG Graphite X-brace

1424 - 4-40 x 1/4"
Flat Head



1435 - 4-40 x 7/16"
Button Head

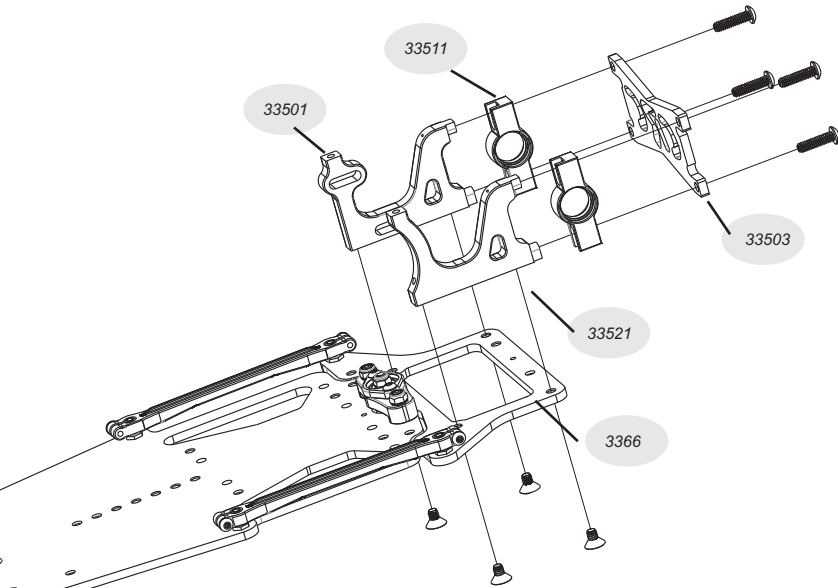

**NOTE - The 4 button heads in the rear of the car will be tightened fully later when setting the proper ride-height of the car. This is accomplished by placing the CRC 4259 ride height gauge under the 3366 rear pod at the desired height. Loosen the button heads and the axle will drop to the set ride-height. Then carefully tighten the rear button heads to lock the ride height.*

Tweak Plate

Bag 4

3387 - Molded Plastic Spring Holder



3288 - 4-40 x 3/8"
set screw



3375 - Molded 1/2"
Standoffs (4)

13615 - Red Low-Profile Ball



1793 - Pro Tapered Springs .50mm



32113 - Tweak Plate

1436 - 4-40 x 3/8"
Button Head



1437 - 4-40 x 5/16"
Button Head



1424 - 4-40 x 1/4"
Flat Head



Tweak Spring assembly

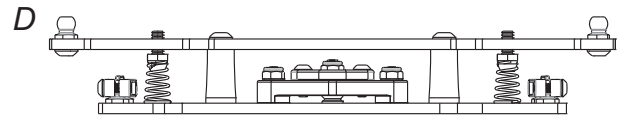
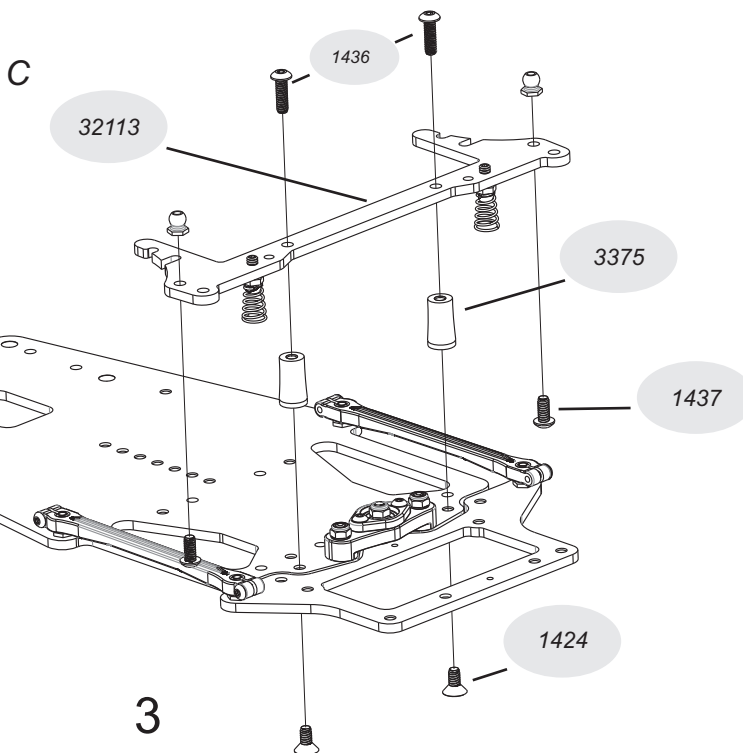
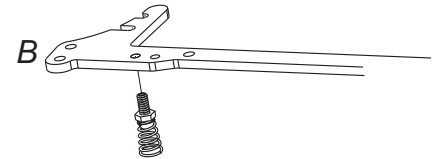
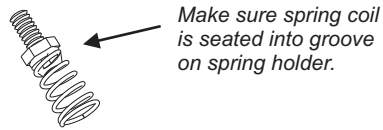
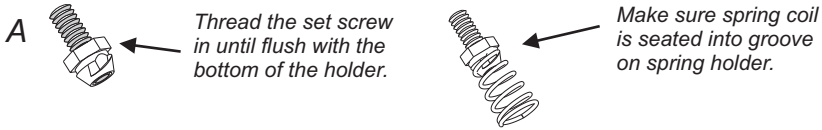

A. Thread the spring holder flush with the bottom of the set screw. Pop the spring on the holder.

B. The tweak spring assembly self-taps into the 32113 graphite cross plate from below. Place the tweak spring assembly on a table. With the 32113 plate parallel to a table, center the set screw in the corresponding hole of the 32113. Line it up and apply a little pressure. Use a .050" allen key and turning the screw counter-clockwise to make the set screw self-thread into the carbon.

C. Mount the tweak plate assembly to the chassis.

D. Adjust the spring height so the spring just slightly touches the rear bottom plate.

Top Plate

Bag 4

3365- Ck25
Rear Top Plate

13615 -
Red Low-
Profile Ball



1437 - 4-40 x 5/16"
Button Head



1434 - 4-40 x 1/4"
Button Head



1433 - 4-40 x 3/16"
Button Head



13844 - Small
hexball for tube

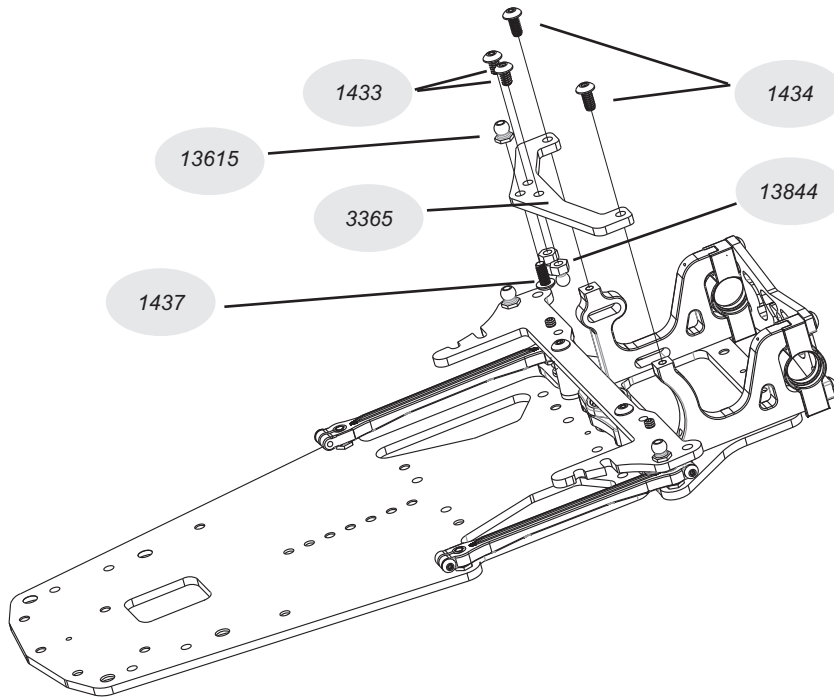

Keep a close eye on the screws that hold the top plate to the motor bulkheads. These screws are subject to a great deal of stress and force and will loosen up if not maintained.

Damper Tubes

Bag 5

1397 - 2-56 set-
screw stud



1384 - 2-56 Steel Ballstud
& Plastic Ball Cup

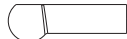

32693 - Delrin Plunger



1288 - 4-40 x 5/16"
set screw



13694 - Short 4-40 Plastic
Ball Cup (on tree)



32691 - Aluminum Tube



13695 - .035"
Allen Driver

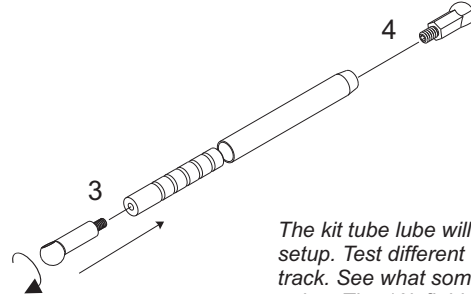
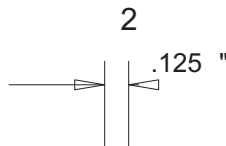
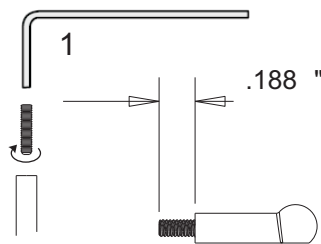
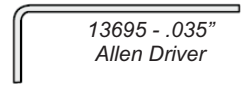

Option CRC Tube Lube

- CRC 4505 - 5K
- CRC 4510 - 10k
- CRC 4520 - 20k
- CRC 4530 - 30k

The kit tube lube will get you started with a good setup. Test different thicknesses at your local track. See what some of the other drivers are using. The 10k fluid is the most popular for the CRC race team.



Tube lube packet

5 - Add CRC Tube Lube to each slot on the delrin plunger.

*** Note: fill the slots, and cover the male plunger with a thin coat of silicone lube. Do NOT fill the aluminum tube. ***

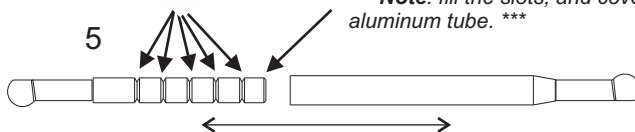

** Adding the Damper Tubes to the Chassis assembly **

Snap the assembled & lubed damper tubes on the respective points as shown in the diagram to the right. You will find it easier to snap on the centered, smaller OD ball studs first, then pop the outer, larger 4-40 ballcups

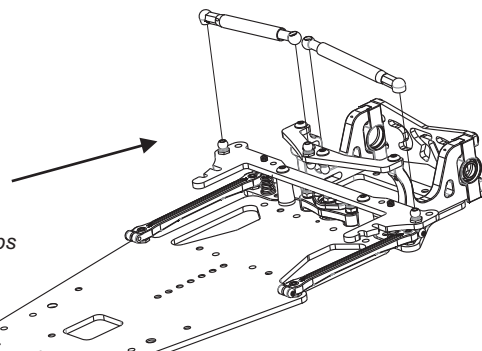

Battery Mount

Bag 6

1424 - 4-40 x 1/4"
Flat Head



3373 - Plastic Battery Position Pieces

1261 - Battery Retention O-ring

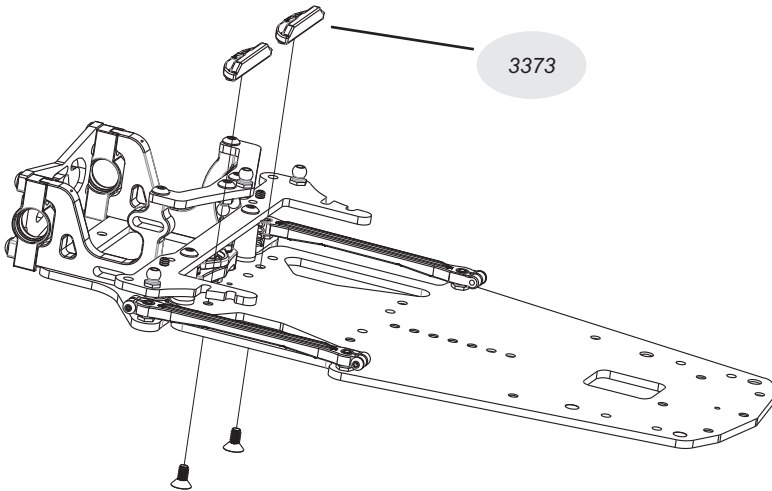

The battery blockers can be installed in the rear holes to move the battery forward. The battery forward position is a bit more stable, with a little less steering and rotation. Typically used in modified, super stock and ultra-high grip conditions.

With the blockers in the front position, the battery is moved rearward giving better rotation, more steering and a more aggressive car in general. Used for stock racing and on lower grip conditions.

The blockers can be removed for even more battery adjustments, however, the race battery will need to be taped in place instead of using the O-ring retention system.

Center Shock

Bag 7

3354 - CRC Shock/Ant Mount

1347 - Fiberglass Anti-Roll
Antenna (optional)

13615 -
Red Low-
Profile Ball



1428 - 4-40 x
3/8" FH



1391 - 4-40 x 1/2"
Set Screw



13783 - 4-40 x 1/8"
Set Screw

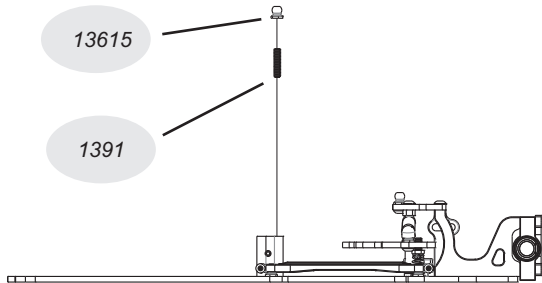

Threaded ball flush/even with top of ball

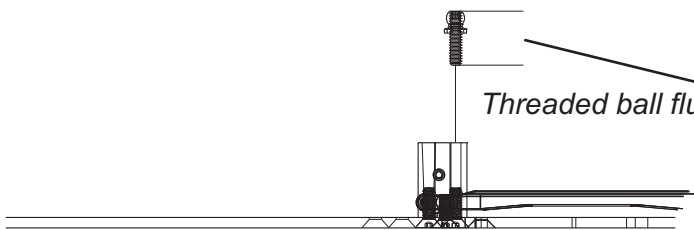

1347
(Optional)

13783

3354

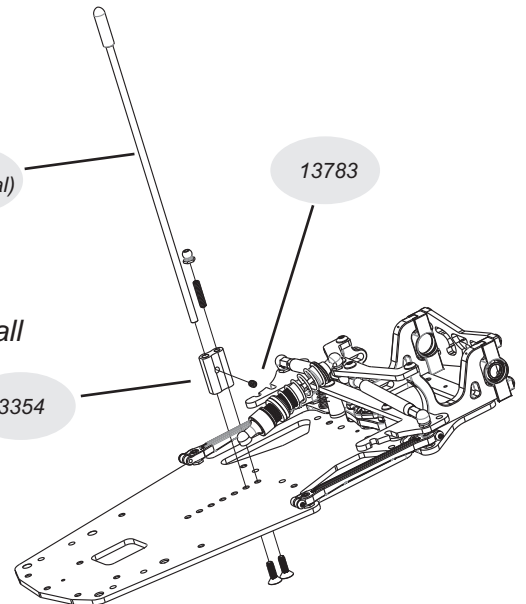

The shock mounting positions are subject to a great deal of force and stress. The strength of the front shock pivot ball relies on the steel set screw being fully engaged in the pivot ball. When fastening the pivot ball to the steel threaded set screw, be sure to run the set screw high up in the ball, flush with the top as shown above.

Antenna/Shock mount options

The antenna/shock mount can be moved forward with the additional mounting holes that are furnished on the CK25 chassis. When moving the shock forward, use the long ball cup and/or the CRC (3296) shock extender to lengthen the shock to accommodate the forward position.

1 - Thread the spring adjuster nut onto the shock body as shown. *This needs to be installed first or you will not be able to get it on later after the lower end of the shock is assembled!*

2 - (2.1, 2.2, 2.3 shown below) Insert only 1 of the small o-rings into the lower end of the shock body. Next, install the bottom shock plug and tighten the bottom shock cap.

3 - (3.1, 3.2 shown below) Insert 1 of the small e-clips into the lower groove of the shock shaft. Slide the piston over the shaft until it stops against the e-clip and then secure it in place with the other e-clip in the end groove.

4 - Put a small dab of the included shock oil on the threads of the shock shaft to lube it and then slip an o-ring on the shaft. This internal o-ring acts as a top-out bumper. Slide the shock shaft through the bottom end of the shock carefully so you do not damage the sealing o-ring with the threads on the shock shaft. Pull the shaft all the way through until the piston bottoms out in the shock body.

5 - Wipe off any excess oil from the threads of the shock shaft and then thread on the shorter of the 2 included ballcaps. *If you need to hold the shaft with pliers, be sure to wrap a rag around the shaft first so the pliers do not damage the shaft. If there is any damage to the shaft, the sharp edges will damage the o-ring and cause the shock to leak.

6 - Now with the shaft still fully extended, hold the shock body upright and fill with the included shock oil. Press the shaft in about half way and then return it to full extension. Look inside the shock and you will notice small air bubbles in the oil. This is the rest of the air that was trapped below the piston. Allow enough time for the air bubbles to work their way to the surface and pop.

7 - Once satisfied that all of the air is out of the shock, top off with oil and then insert the shock bladder by laying one side into the oil and then rolling your finger across the top of the bladder to expel any excess air and/or oil.

8 - (8.1, 8.2 shown below) Insert the flanged ballcap into the upper shock cap and then tighten this down over the shock bladder, being careful to not knock the bladder off its seat and allowing air to enter the shock. *Double check that the shock is working smoothly through its range of motion and that you can fully compress the shock. If it binds up before being fully compressed, then it has too much oil and you will need to crack the top cap loose and expel a very small amount of oil and re-tighten.

9 - (9.1, 9.2 shown below) Slide the shock spring over the shock body and keep in place by clicking the spring retainer over the shock shaft and sliding it down over the short ballcap to keep it in place.

Encore Shock Parts List:

- 3291 - Encore Shock-Body + alum parts
- 3292 - Encore Shock Shaft - Hardened
- 3293 - Encore Shock Plastic Parts
- 3294 - Encore Shock E-clips (10)
- 3295 - Encore Shock Rubber Parts
- 3296 - Encore Shaft Adapter, 4-40 ballcup (option)

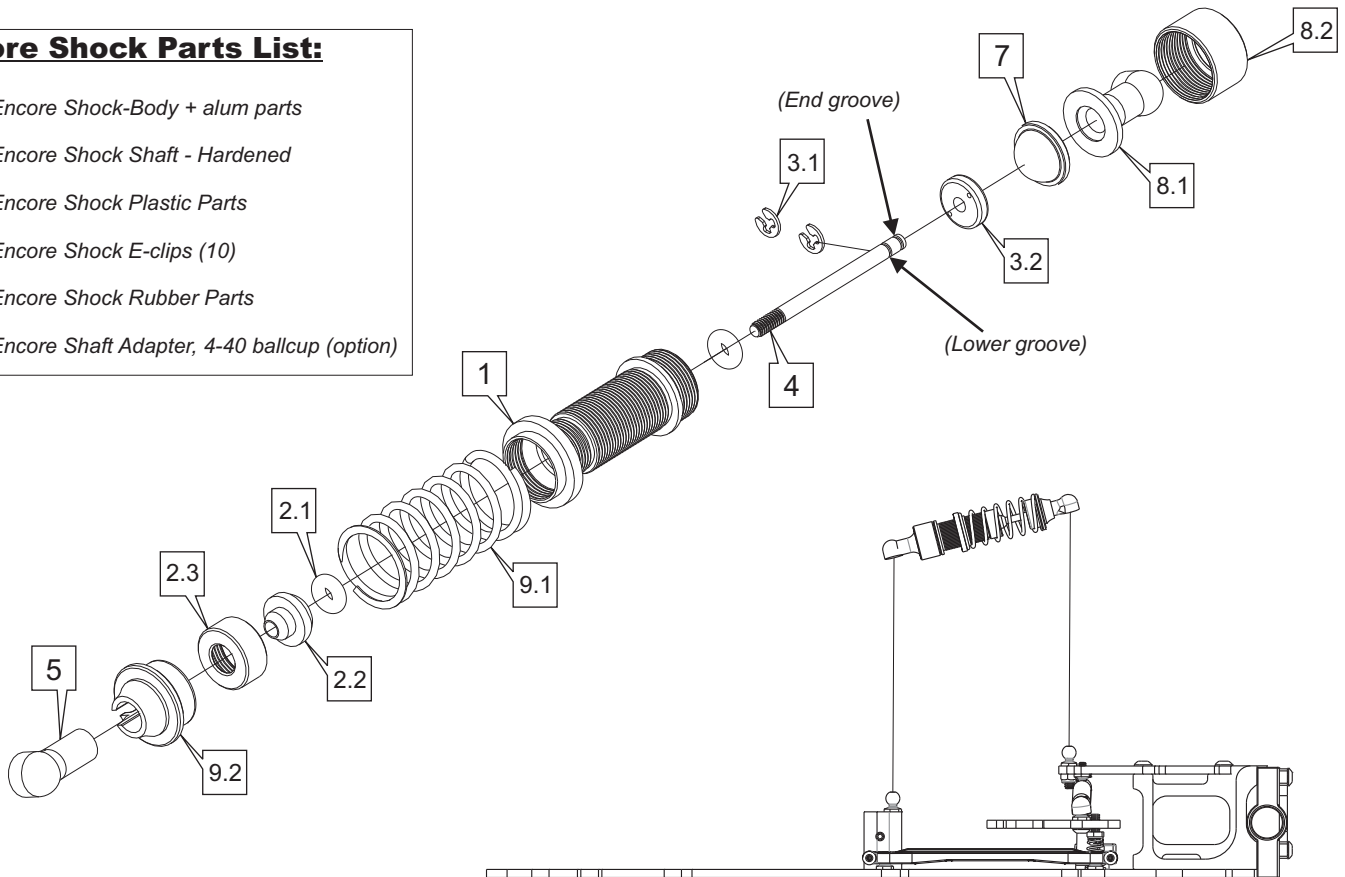

CRC Pro-Strut
Front End
Bag F

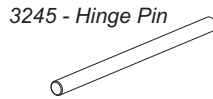

3247 - CRC Front Arm set-lower and upper

3243 - Upper Arm mnt set-0,5,10

3233 - Molded ride height spacer 3mm

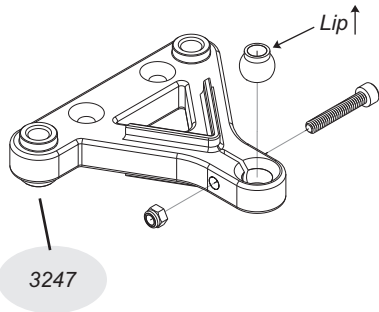
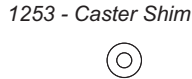
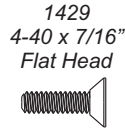
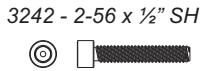

1 - Pop the pivot ball into the lower arm. Place the arm on a strong table and push the ball in with the back of screwdriver handle. Or preferably, you can use CRC's 4279 Ball popper pivot ball tool. Notice the "lip" of the pivot ball is pointing upward. The diagram to the left represents a right side lower arm. For the left side, flip the second arm over and be sure the pivot ball is installed with the lip again facing up.

2 - Once the ball is popped in, insert the black 2-56 clamp screw through the horizontal hole in the lower arm. Thread the 2-56 red locknut onto the black screw. Tighten the screw slowly continuously checking the pivot ball. When it begins to bind a bit, back the 2-56 screw off a bit. The ball should be free to pivot with just a bit of drag. There is no need to have this ball super loose and free, a slight drag will be just the right amount of clamping force.

Check this fit after a few runs as the ball will wear and require additional clamping force.

1 - Install the upper A-arm mount with the amount of Dynamic Caster desired. The options are 0, 5 and 10 degrees. The part shown to the right in the diagram is the 0 degree version, however it is most common to use 5 or 10 degree blocks for road racing. The 5 and 10 will angle down more toward the front of the car. The general thought is the more Dynamic Caster, the more steering the car will have at corner entry. We recommend starting with the 5 degree unit.

2 - Push the 4-40 x 7/16" screw through the 3mm ride spacer and lower arm and then thread the screw into the upper A-arm mount. Be sure NOT to over tighten. Just snug, you are threading a metal screw into the plastic upper A-arm mount.

*Note - For fine front ride height adjustments, use the CRC #4262 optional front shim set. This set contains .010, .020 and .030" plastic ride height shims.

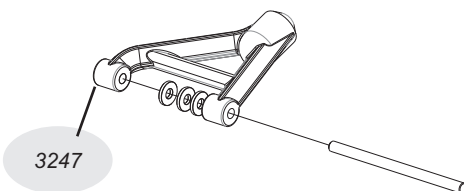
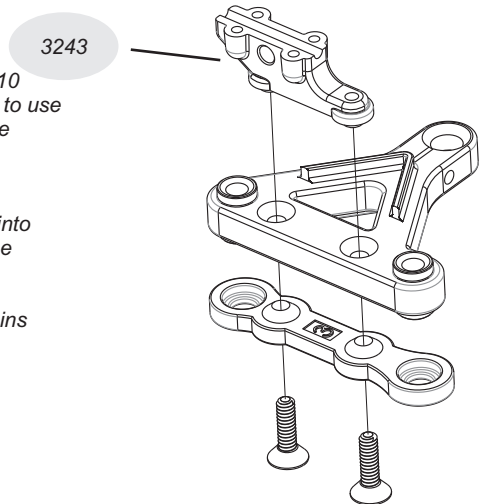

1 - Locate the upper A-arm. You can clean up the mold gates with a hobby knife or rotary tool.

2 - Locate the upper arm hinge pin and slide it into one half of the upper arm. Locate 3 small caster shims. Push the hinge pin through the 3 shims. Then continue to push the hinge pin all the way into the upper arm.

3 - Now, install the arm/pin/washer assembly onto the upper arm mount. Put the hinge pin in the channel. At this point you can set your starting caster setting by moving these washers forward and back. The position shown to the left will result in a competitive handling. Moving them to the rear will increase steering from the center and exit of the corner.

If the fit of the upper arm is tight, trim the upper arm mount SLIGHTLY with a hobby knife.

4 - Install the upper cap with four 2-56 button head screws. The topper is the "clamp" for the hinge pin. Be sure to tighten so that any gap is gone, however, do not tighten beyond that point as damage can occur to the upper a-arm mount holes.

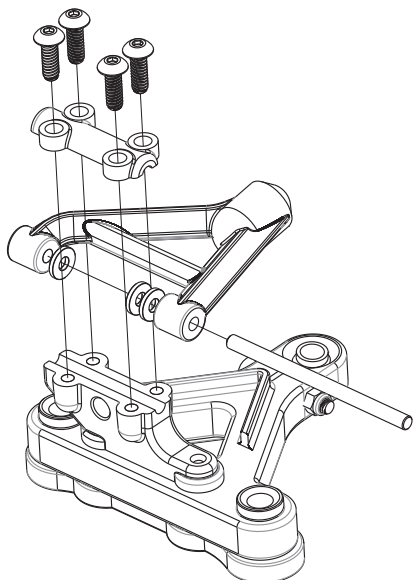

CRC Pro-Strut Front End - cont.

1434 - 4-40 x 1/4"
Button Head



1412 - Red Locknut



1382 - E-Clip



3250 - King Pin



3244 - Upper Pivot Ball

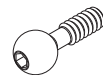

13615 - Red Low-Profile Ball



3221 - Steering Block Set

1236 - Steel Stub Axle

3392 - .50mm Front Spring

3234 - Brass Set Screw

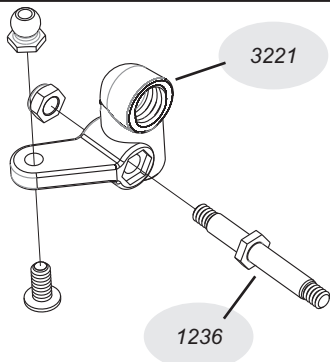

1 - Build up the left and right steering blocks as shown to the left. Start by threading the 1/4" button head screw through the steering arm of the block and into the red low profile ball.

2 - Then, slide the steel stub axle into the steering block as shown, and secure it in place using the red 4-40 locknut.

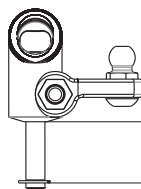

.402" (10.2mm) - distance from bottom of steering block to the bottom edge of e-clip slot

1 - Locate the e-clip and snap it into the groove of the King Pin. Slide the Front End Spring down over the threaded end of the King Pin until it rests against the e-clip.

2 - Using an .050" hex wrench, slide the king pin/spring/e-clip assembly through the lower arm pivot ball, & then thread it into the steering block. Thread it in until the front spring just touches the lower arm pivot ball. You do not want any preload on this spring, but you don't want play either. Only run the king pin in until the spring just touches the ball.

3 - Once happy with the king pin/spring preload position, lock the king pin with the 4-40 brass set screw through the hole in the side of the steering block.

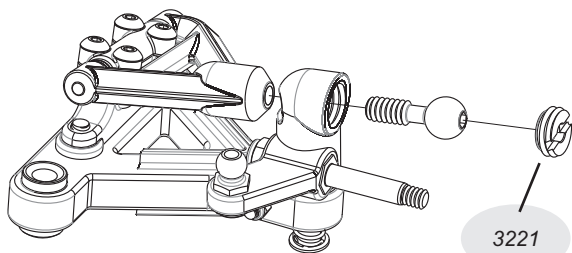
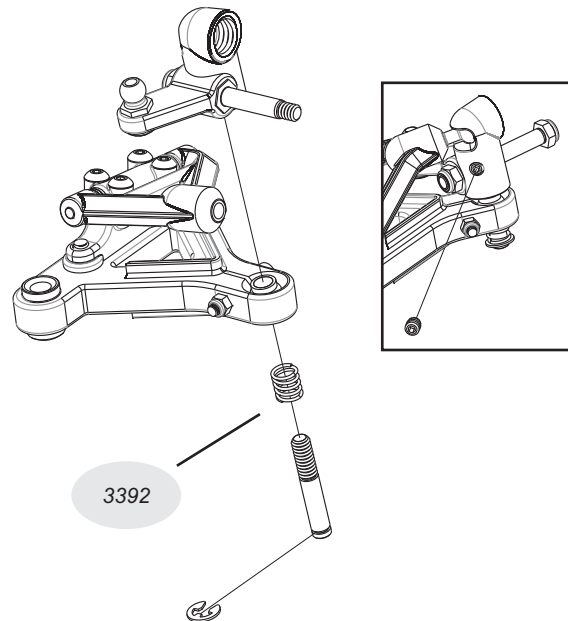

1 - Take the upper pivot ball and push it through the steering block and thread into the upper arm. Thread it in so there are no threads showing.

2 - Take the slotted capture insert and thread it into the steering block. **THIS IS A BIT TRICKY ...** as the insert must be fitted at a down angle as shown to the left. **DO NOT** try to insert it horizontally into the steering block. It is actually threaded in at a down angle toward the center of the car.

3 - Tighten this capture insert so that the steering movement is bound and slow. Yes, we are actually slightly over tightening this piece **FOR NOW**. With the steering movement bound from over tightening, move the steering to it's limits, back and forth. What we are doing is "breaking in" the upper ball/capture insert. After a minute or so of break in, loosen the insert just enough so the steering is free. Not too much or you will induce excessive free play.

CRC Pro-Strut Front End - cont.

12394 - 8-32 x 1/2
100 degree Flat Head



12393 - 8-32 x 1/2
100 degree Flat Head
*** Optional Titanium ***



Use the large 8-32 screws to mount the front suspension assembly to the graphite chassis. Tighten the screws firmly, but be careful not to strip the threads in the arm.

The CK-25 is designed for all out performance on high bite tracks. Typically, the front tire size used in these conditions range from 39 - 42 mm. When using tires in this range, fine ride height adjustments are made with the optional 4262 shim set.

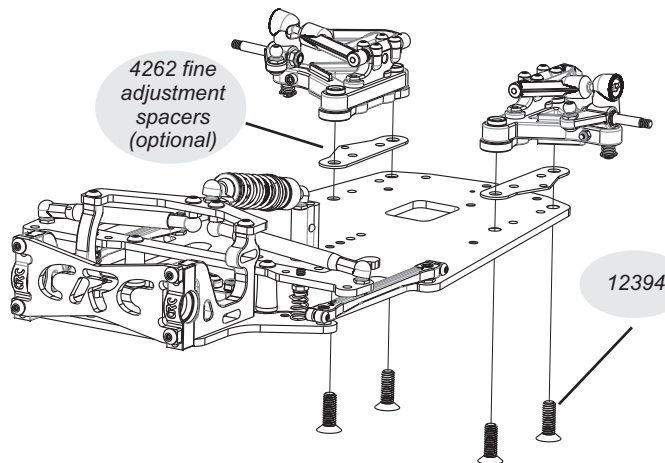

CRC Pro-Strut Front End - cont.

- 33581 - Carbon Fiber Servo Slider plate
- 3376 - Molded Servo Saver Brace
- 1231 - Short Ballcaps
- 1317 - 42mm Turnbuckles

- 1434 - 4-40 x 1/4" Button Head

- 1412 - Red Locknut

- 1436 - 4-40 x 3/8" Button Head

- 1738 Hex standoff

- 1424 - 4-40 x 1/4" Flat Head

- 1209 - washer

- 3355 - Alum Vertical Mount Set-Red

- 13615 - Red Low-Profile Ball

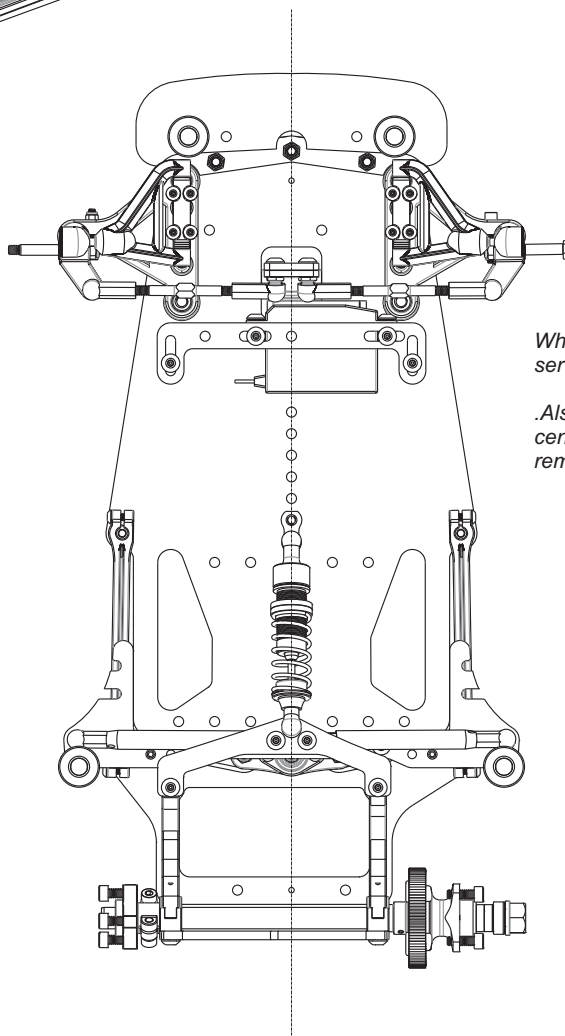
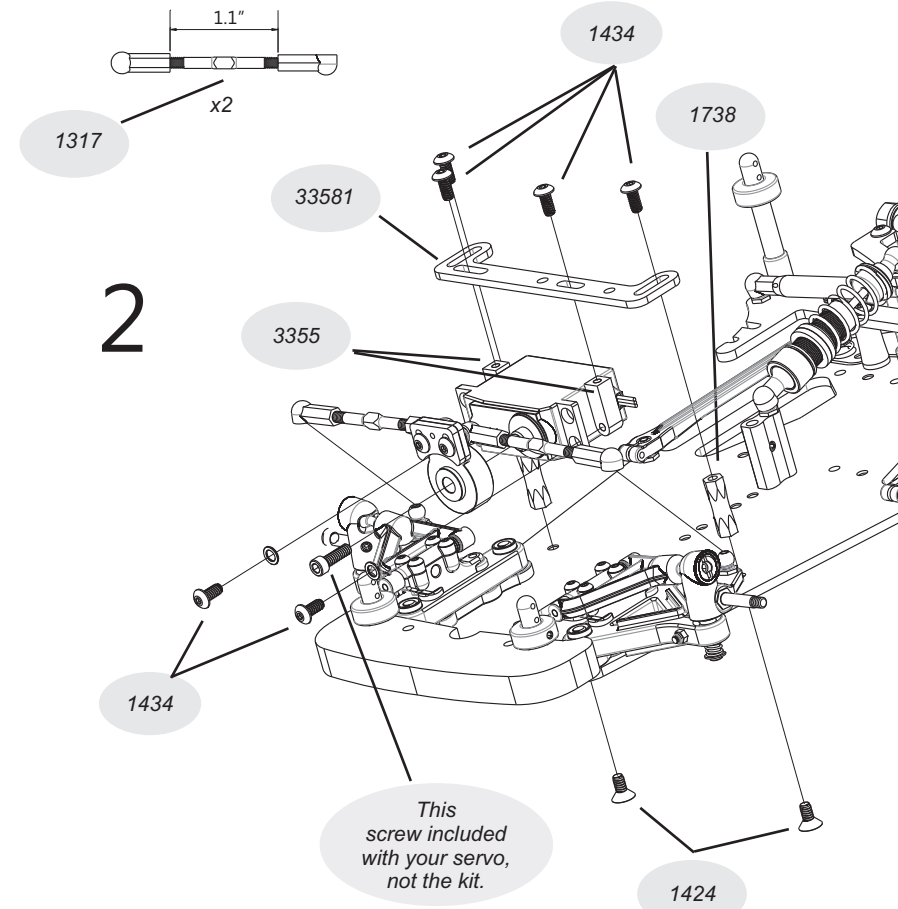
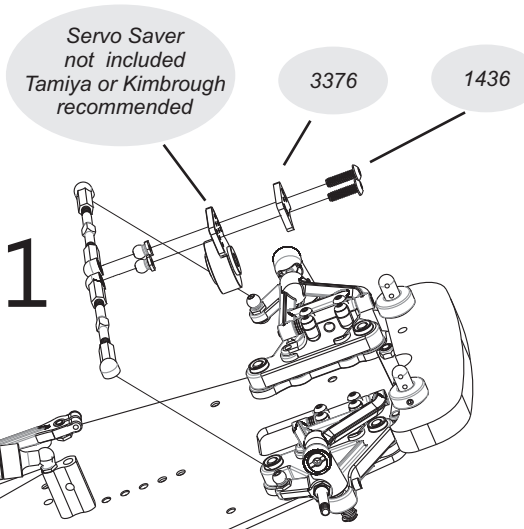

When installing the servo, use the slotted adjustable mounting points to center the servo. The servo spline drive should be aligned down the centerline of the car

Also, slide the servo forward on the slotted mount so that the tie rods are 90 degrees to the center line of the car. To allow for a slightly more forward position, the 1209 washers can be removed.

**** Optional Sanwa Servo placement ***
The Sanwa mini servos are very small and can be mounted in the "reverse" position, between the front arms.

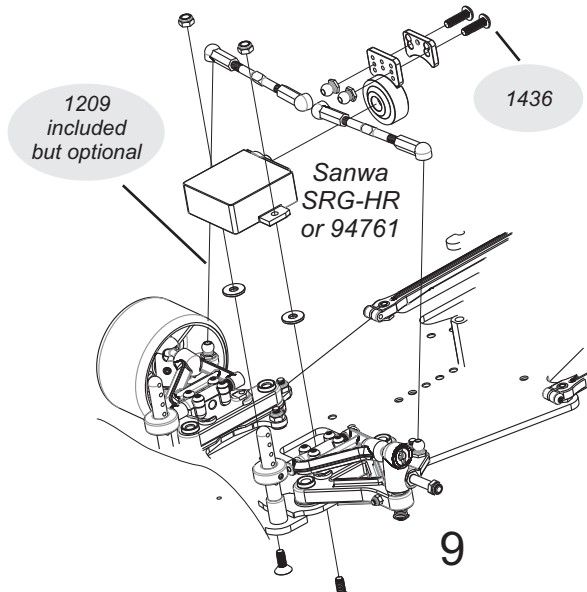

Differential Axle

Bag 8

4720 - Axle Spacer-



1386 - 1/4" x 3/8" Flanged Bearing



4732 - 1/4" Shim



3332 - M2.5 x 6 Clamp screw



1528 - Large D-ring Axle - 4mm stud

3331 - Double Clamp Left Hub

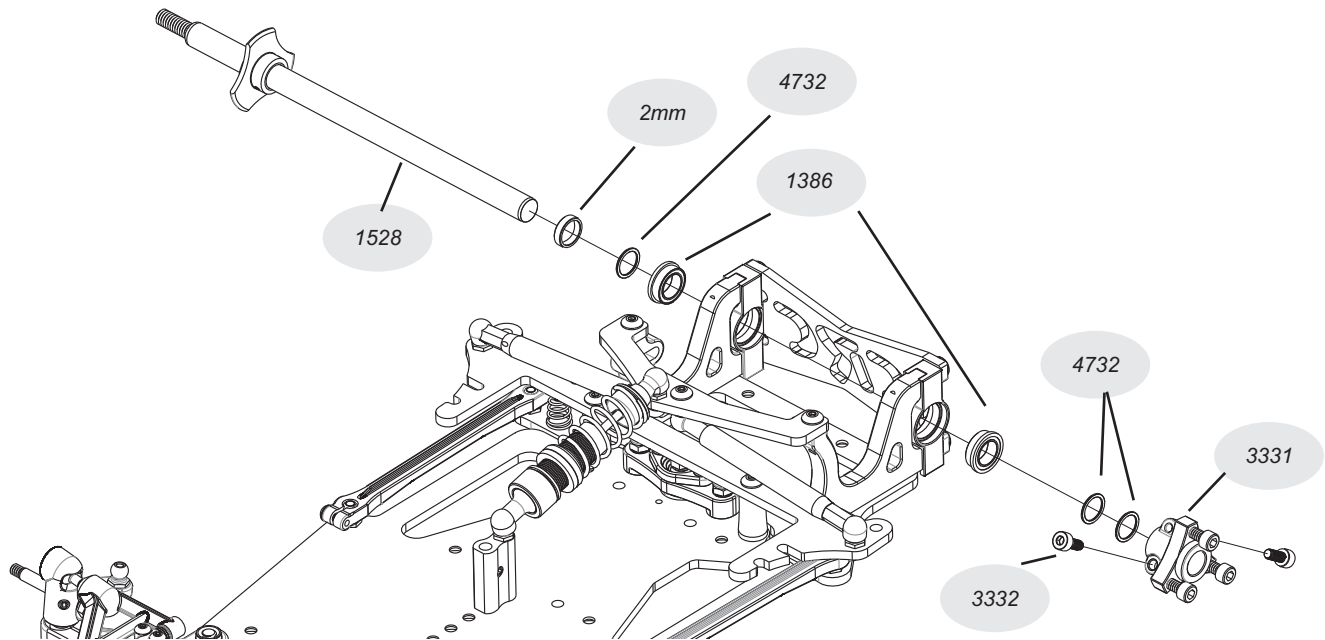

Differential

Bag 9

4201 - Diff Ring



1387 - 1/4" x 3/8" Plain Bearing



4121 - Diff Spacer



4123 - Spring Washer



4126 - Nylon Diff Nut



4227 - Diff Hub

1227 - 2.5mm Diff Balls

** Balls in outer ring of holes in gear **

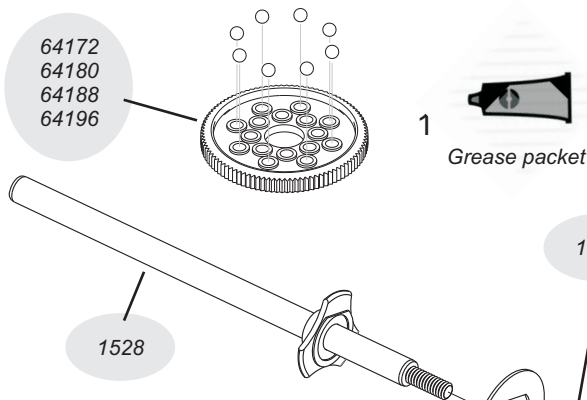

1 - INSTALL AND GREASE THE DIFF BALLS

Place the spur gear flat on the table in front of you with the side that says "CRC" facing down. The diff balls will pop into each of the outer ring of holes in the diff gear. Place a small dab of silicone diff grease on each ball to lube the ball. Use very little!

2 - DIFF ASSEMBLY

*(Holding the car on it's side, with the rear axle pointing upright will ease assembly of the diff.) Place 1 diff ring, and then a 1/4" x 3/8" plain bearing over the end of the axle. Align the diff ring so that it notches into the axle flange. Place the assembled gear with the greased diff balls over the axle and push it down over the plain bearing. Next, insert the other plain bearing into the back of the diff hub. Then, align the second diff ring with the notch on the back of the diff hub. *(place a small dab of the diff grease on the hub first to hold the ring in place.)* Now, slide the hub, bearing, & diff ring down over the axle. Next, slide a flanged bearing over the axle and into the front of the diff hub. Place (2) 4732 shims over the axle next. (cont)

DIFF ASSEMBLY - CONTINUED...

The diff spacer has a small machined lip on one side, point that lip toward the bearing. Now, place the spring washer so that the cone points away from the gear. The outside of the washer should be against the diff spacer, and the inside of the washer should be against the diff nut, which now goes on last. *Be sure the 2 "D" rings have settled into their notches. Just snug the nut so the parts stay together on the diff axle. DON'T over-tighten so the outer diff hub bearing gets crushed! Correct diff tension needs to be set with tires on the car.

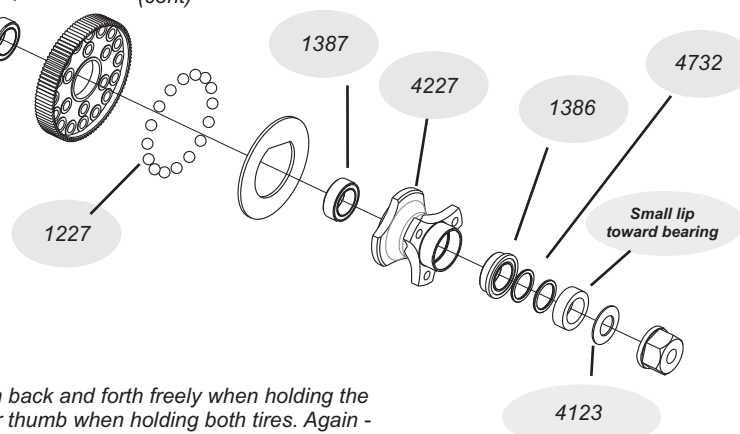

3 - Setting the Diff

Once the tires are on: Adjust the diff nut so that the tires spin back and forth freely when holding the spur gear, but it is very difficult to slip the spur gear with your thumb when holding both tires. Again - DON'T over-tighten so the outer diff hub bearing gets crushed! Re-check diff tension after the first run.

Bag 10

13783 - 4-40 x 1/8" Set Screw



1436 - 4-40 x 3/8" Button Head



1412 - Red Locknut



1426 - 4-40 x 5/16" FH



3261 - Graphite Bumper/body mnt plate

3378 - Short (1 in.) Body Post Set w/ collars

1378 - Body Post Set w/ collars (2 in.)

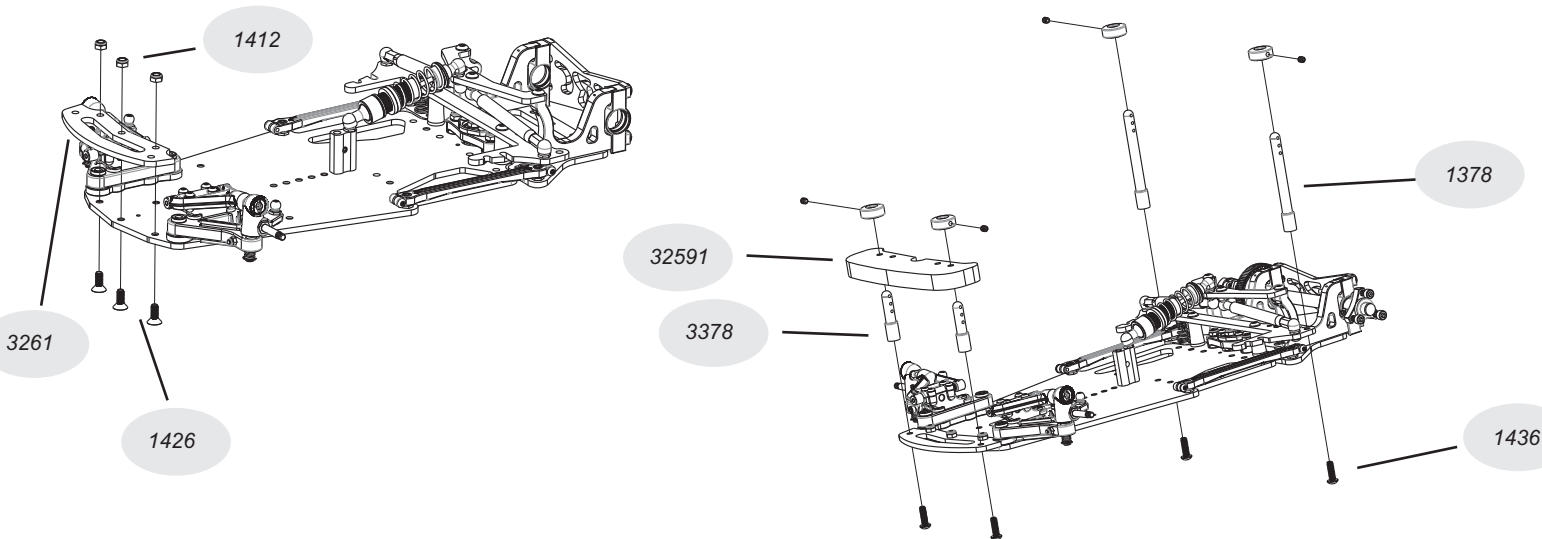

Bag 11

4731 - 1/8" Shim



1248 - 1/8" x 5/16" Flanged Bearing



1412 - Red Locknut



1460 - 4-40 x 5/16" Red Socket Cap



1207 - M3 x 8mm Motor Screw

1208 - Motor Screw Washer

1 - Use the 4-40 x 5/16" red cap head screws to bolt the rear wheels to the hubs. (Tires not included)

2 - Insert the flanged bearings into the front wheels. Slide the front wheel onto the axle, & secure with a red locknut. The front wheels should spin very free. Do not over-tighten the front wheel nuts so that the bearings are pinched.

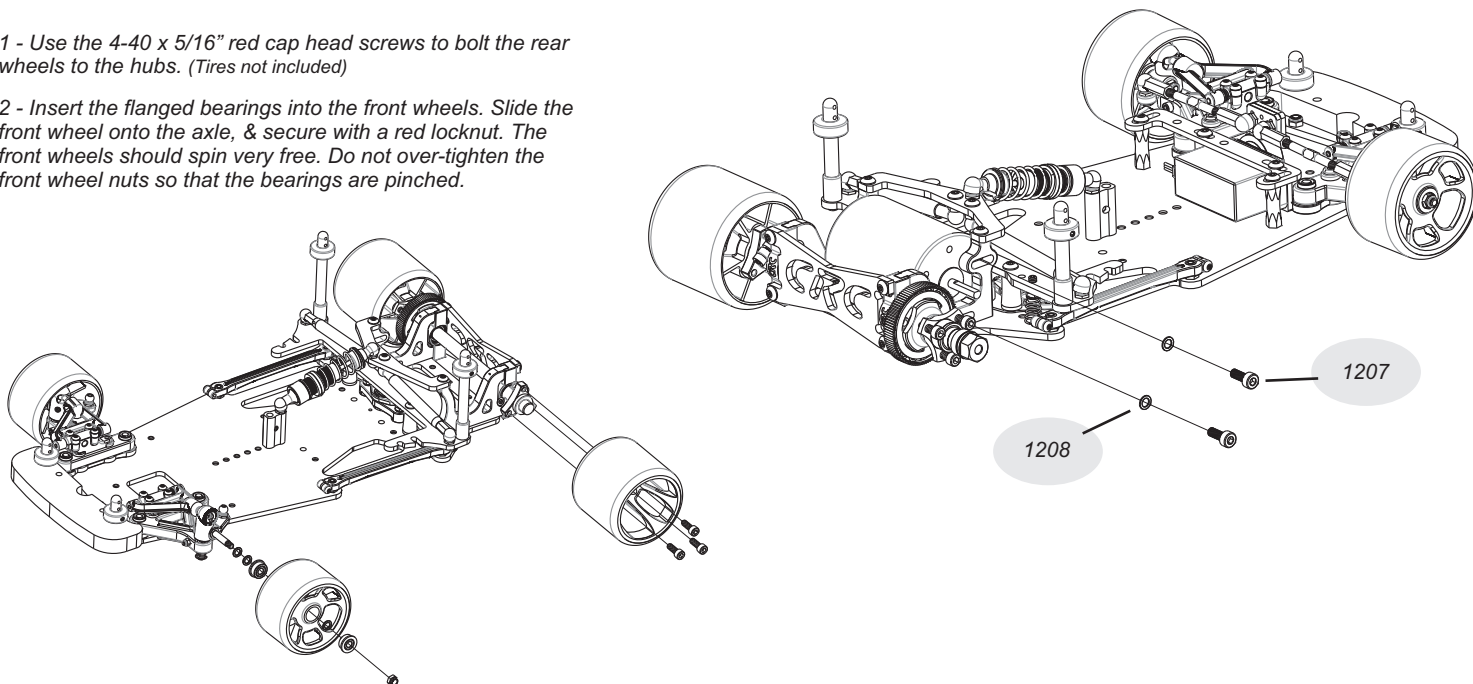

Thank you for choosing Calandra Racing Concepts and the Carpet Knife Twenty-Five race car. If you have any questions or concerns about any CRC product, feel free to call or e-mail the staff at CRC for assistance. All of our in-house staff at CRC are experts in building, setup, driving and racing R/C model cars. Your new CK 25 was handled by experienced racers from the moment of design right through the completion of the kit. We utilize our top driving professionals around the world as well as feedback from local racers at the CRC test track to build you the most complete and competitive product possible. Our team travels to major events around the world, please stop in at a race if you need any help or just to say "Hi!". Have fun, practice often and good luck!

CALANDRA RACING CONCEPTS

6785 Martin Street ~ Rome, NY 13440
Tel + Fax 315-338-0867 ~ www.teamcrc.com