

COMPETITION GRADE HIGH PERFORMANCE RADIO CONTROL RACING CAR CHASSIS KIT

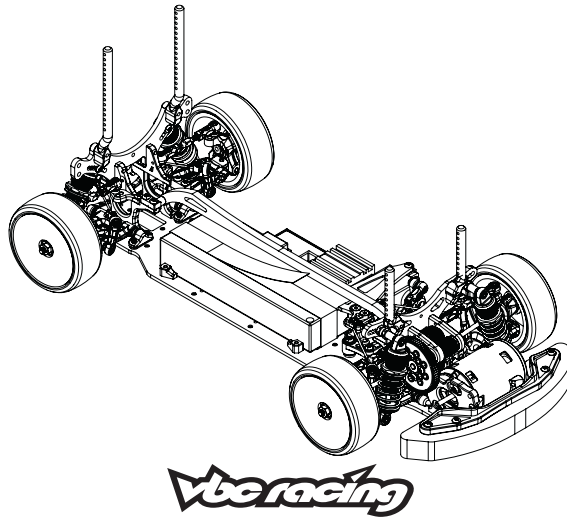

INSTRUCTIONS MANUAL



Thank you for purchasing VBC Racing product.

Things that we should remind you.

This VBC Racing kit is a high performance, racing grade car kit intended for experienced racers. The kit compose of VBC formulated composite materials, top quality full carbon fiber chassis and high grade 7075 material which will give you a competitive edge over the others.

Novice racer should seek advice from more experienced racer before assembly.

Always keep this instruction manual handy at all times for quick reference even after completing the assembly.

Before your assembly, sand the chassis edges.

Sand the chassis edges with #600 sand paper and apply CA glue to the edges and counter sink holes.

Need help or support.

If you need help or you would like to leave us a comment, please email to our support team: support@vbc-racing.com or visit our web site www.vbc-racing.com



1

Graphite Edges Protection Procedure



*Not included in this kit

Sand the chassis edges with #600 sand paper(not included) and apply CA glue(not included) to the edges of the chassis.

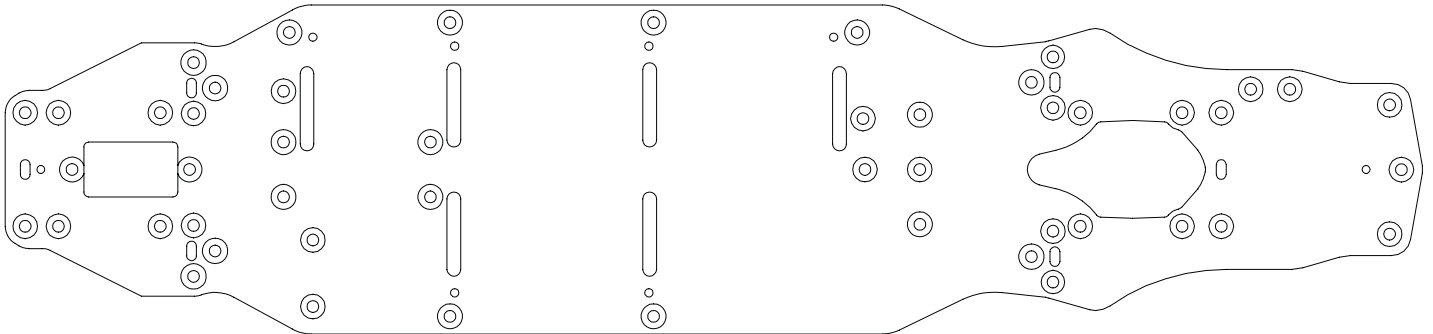

A-01-P21376 FF17 Graphite Main Chassis

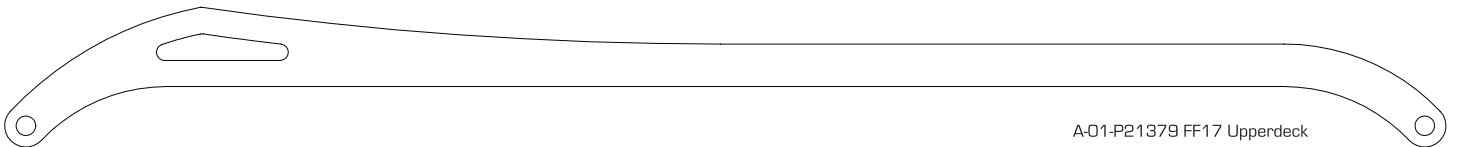

A-01-P21379 FF17 Upperdeck

Sand the below graphite edges with #600 sand paper and apply CA glue to the edges.

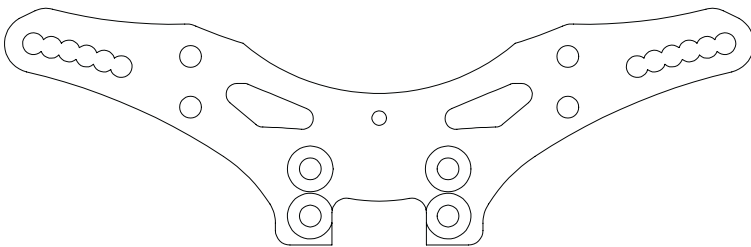

A-01-P21377 FF17 Graphite Front Shock Tower

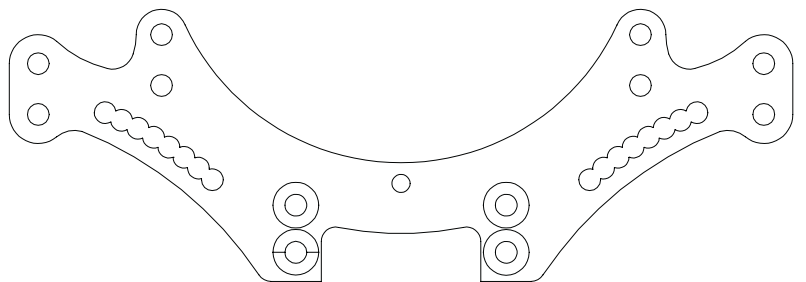

A-01-P21378 FF17 Graphite Rear Shock Tower

2

Gear Differential Assembly

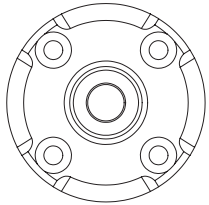

Firebolt Gear Diff Housing B-02-G60399 x 1

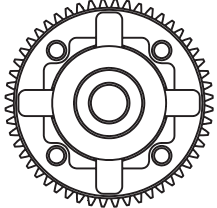

Firebolt Gear Diff 52T B-02-G60398 x 1



Diff Gear 18T A-03-VBC-0019 x 2

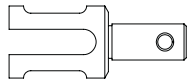

FF17 Heavy Duty Diff Cup C-02-G21337

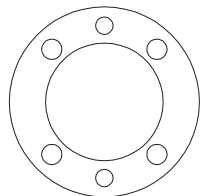

Seal Gasket B-03-VBC-0004 x 1

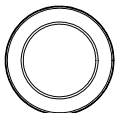

10x15 Ball Bearing C-02-BB-1510-B x 2

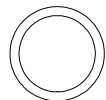

10x13x0.2mm Shim C-02-P30914 x 6

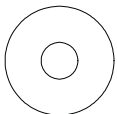

15x0.3 Shim B-02-VBC-0077 x 2



M2x10 Shaft Pin B-02-VBC-0020 x 2



Diff Shaft Sealer O-Ring B-03-VBC-0006 x 2

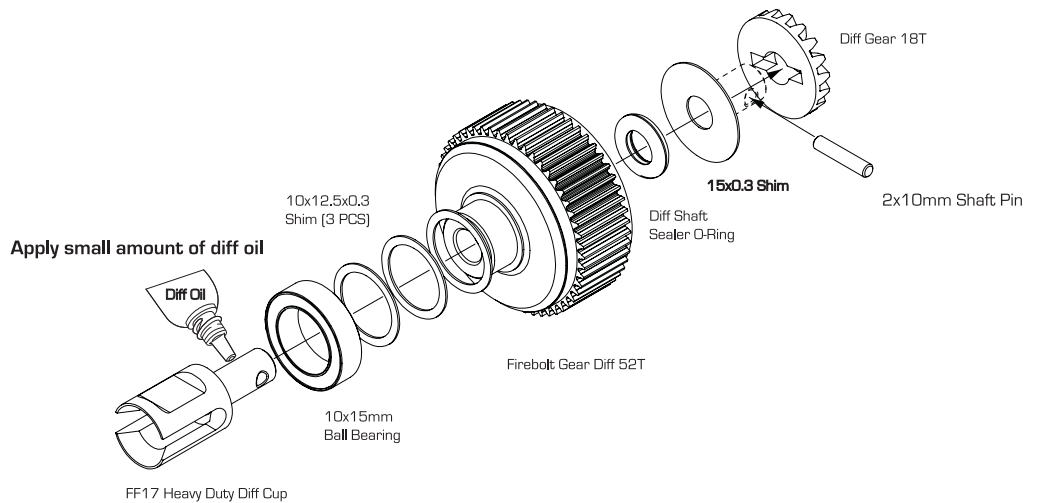
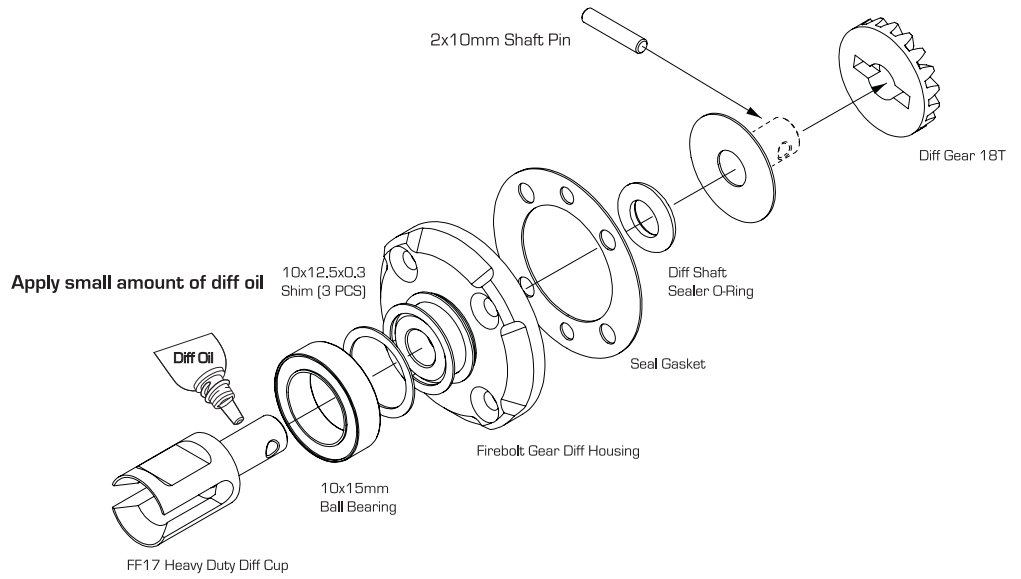

2

Gear Diff Assembly Continue

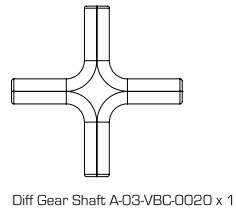
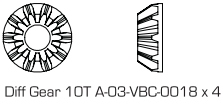
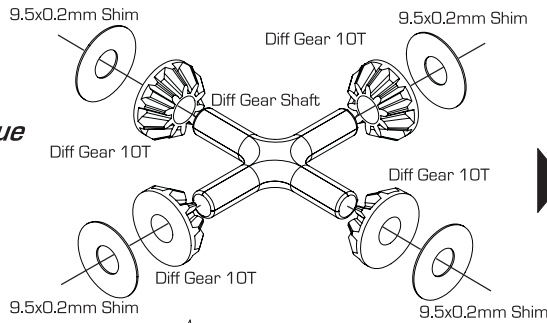

OPTION PARTS **Metal Bevel Gear Set D-06-VBC-0237**

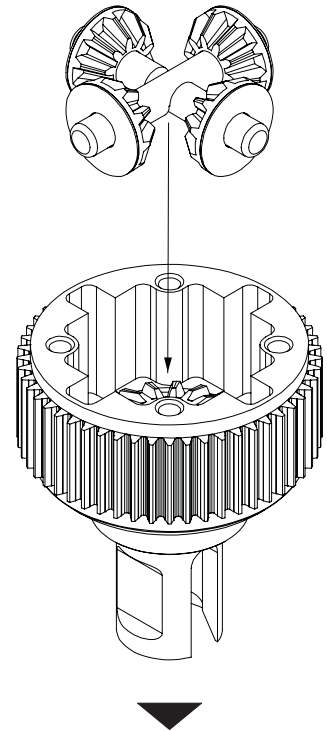
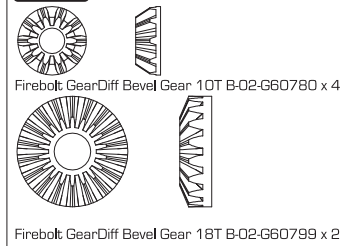

M2.6x10mm Flathead Screw

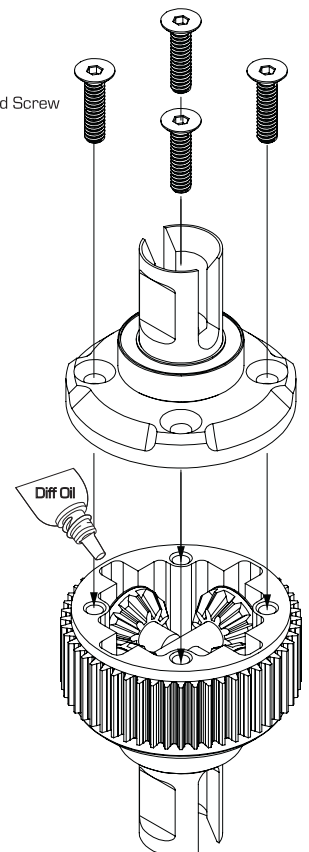

TIP	Gear Differentials			
	Traction			
	Low	Medium	High	
	300K CST		500K CST	

3

Front Bulkhead And Center Suspension Mount Assembly

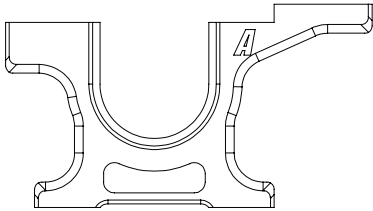

Lower Bulkhead (A) B-02-VBC-2007 x 2

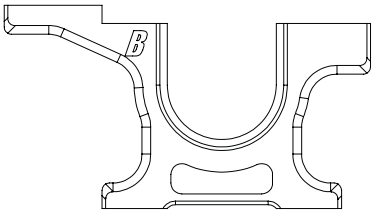

Lower Bulkhead (B) B-02-VBC-2008 x 2



Center Suspension Mount Shim (1mm) x 4
A-01-VBC-0038

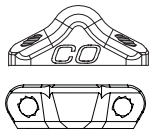

Center Suspension Mount x 4
B-02-VBC-0062



M3x6 Flathead C-02-SC-F0306 x 16

4

Rear Bulkhead And Center Suspension Mount Assembly

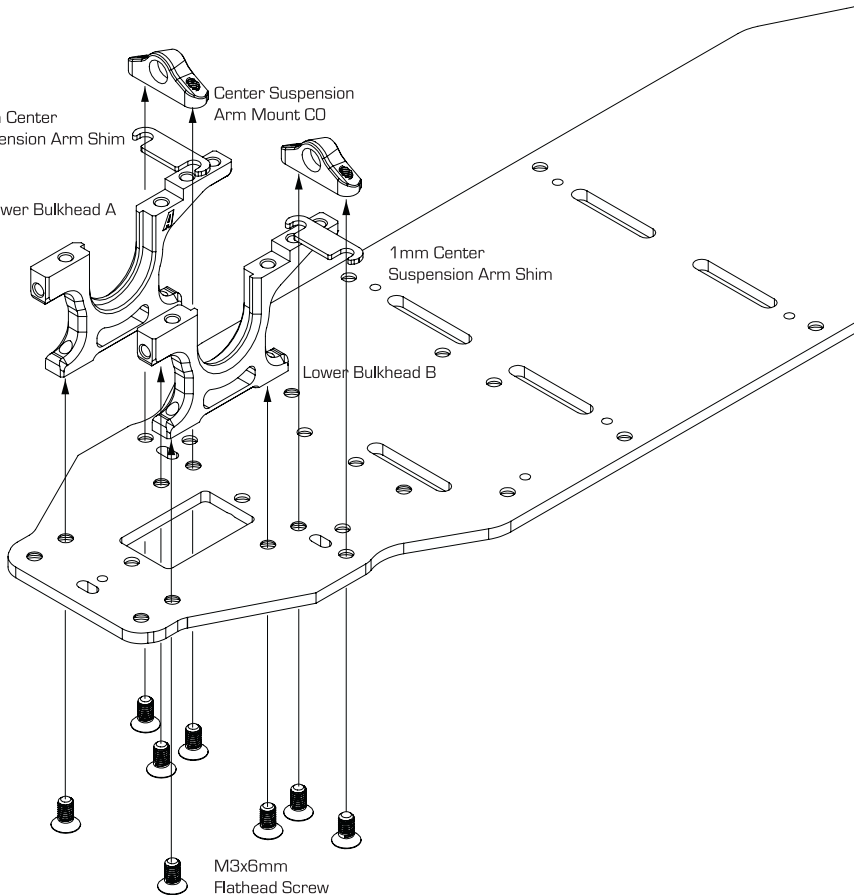
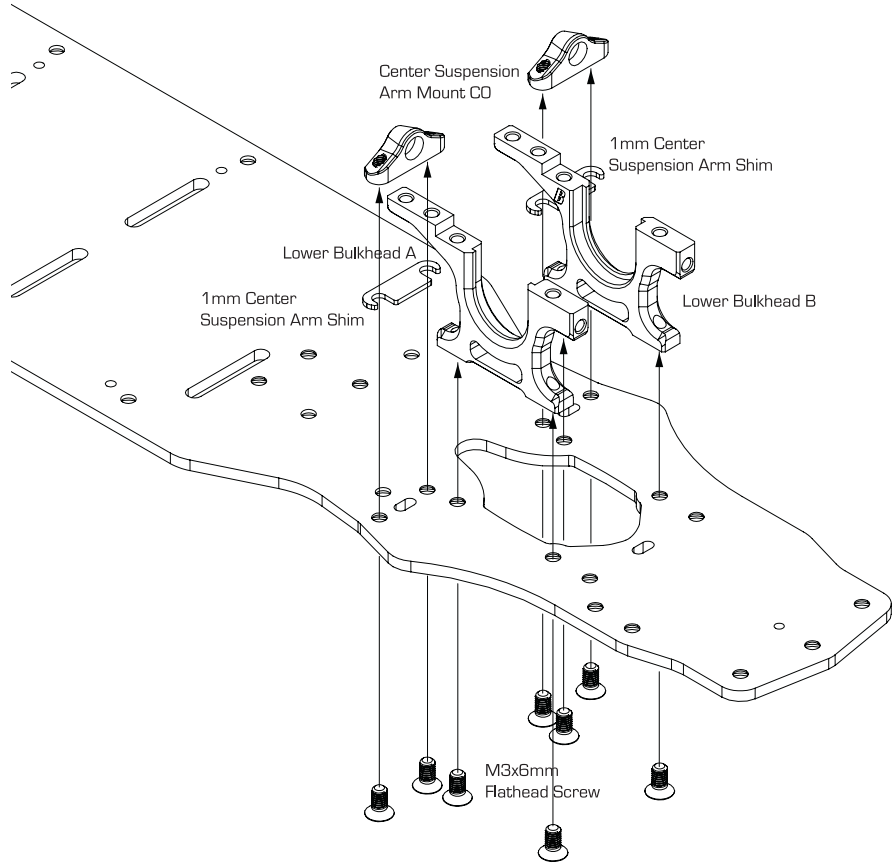

5

Steering System Assembly

Ball Connector (5mm Length) B-02-VBC-3021 x 2

5x8 Ball Bearing C-02-BB-0805-B x 4

3x6 Ball Bearing C-02-BB-0603 x 2

Ball Connector (7.5mm Length) B-02-VBC-3022 x 1

D09 POM Steering Stopper A-03-P31176 x 1

D09 Steering Bridge B-02-P31171 x 1

D09 Steering Arm B-02-P31172 x 2

M3x6 Roundhead C-02-SC-R0306 x 2

M3x42mm Turnbuckle B-02-VBC-0037 x 2

Turnbuckle Cup A-03-VBC-0039 x 4

M3x6 Flathead Screw C-02-SC-F0306 x 2

D09 Steering Chassis Mounted Post B02G31338 x 2

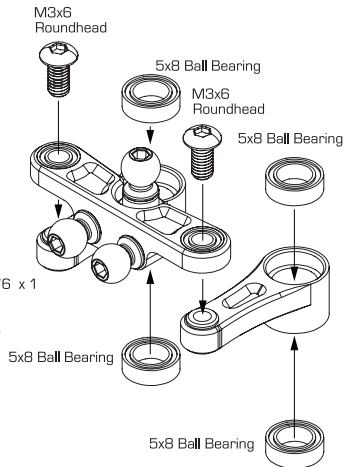

TIP Default Steering Angle Setup (27Deg)

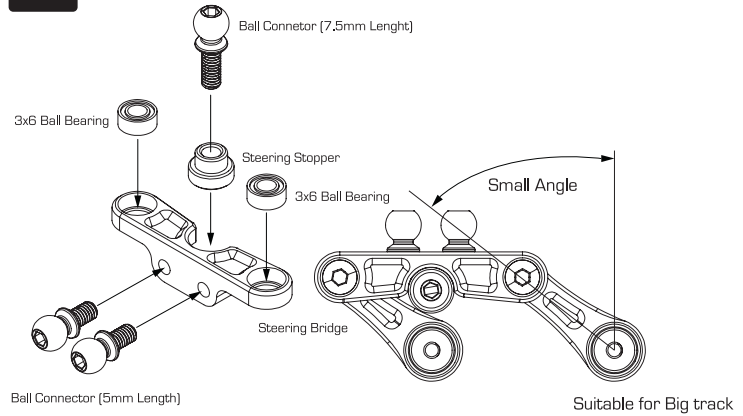

TIP Steering Angle Setup (31Deg)

Steering Knuckles have an inbuilt steering angle limiter for use with big tracks, cut the limiter off when using the car in small track and where large steering angles are required.

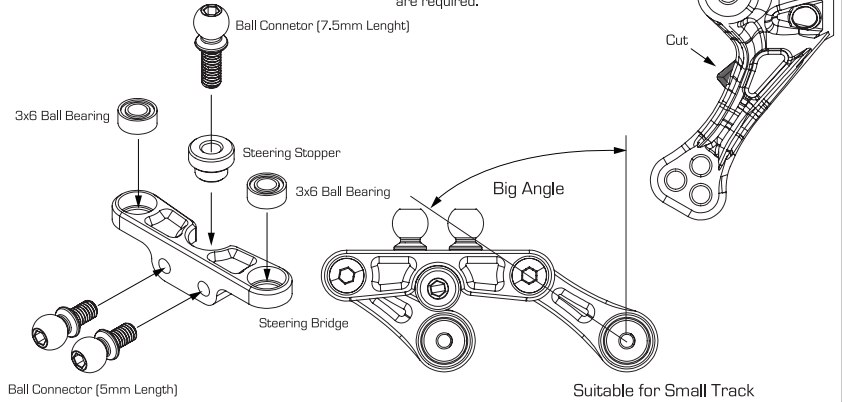

6

M3x6 Flathead Screw C-02-SC-F0306 x 2

D09 Steering Chassis Mounted Post B02G31338 x 2

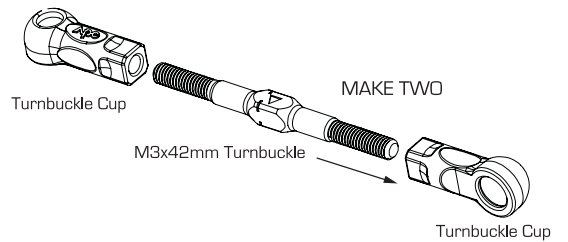
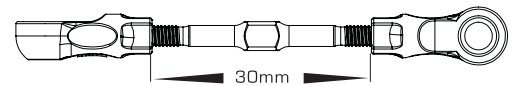
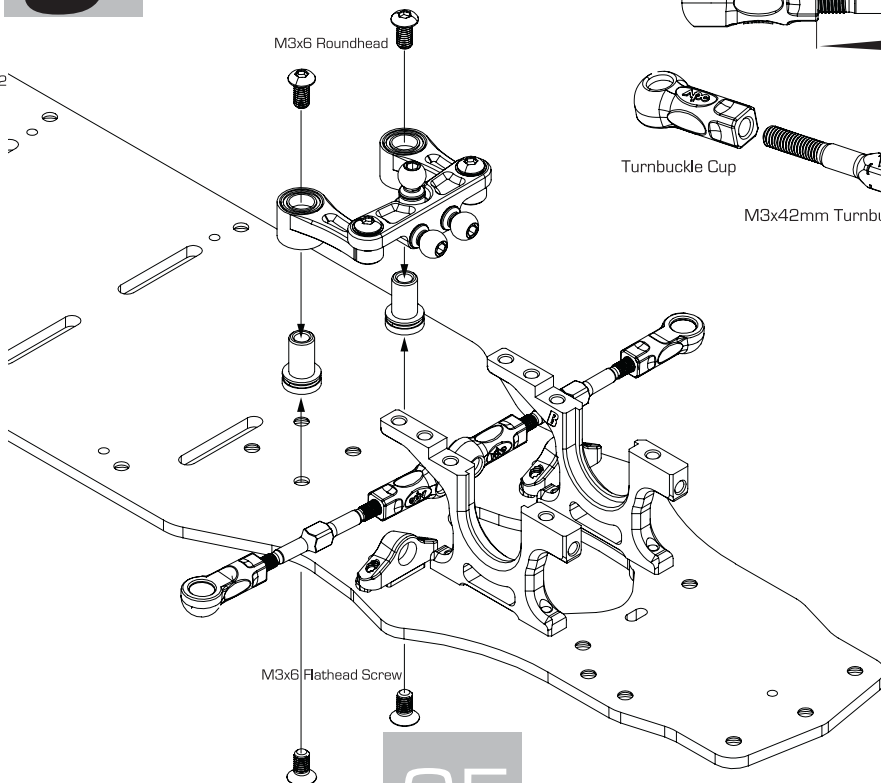

7

Transmission Assembly

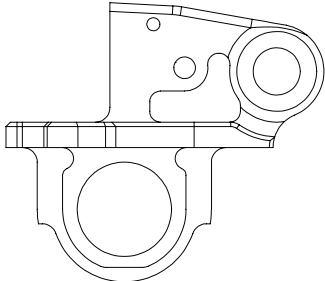

FF17 Front Gear Box (A) B-02-P2141

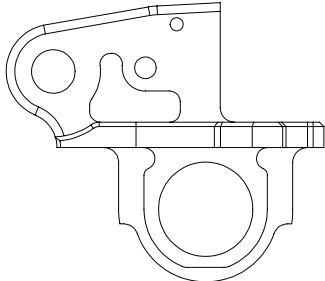

FF17 Front Gear Box (A) B-02-VBC-2024 x 1



Ball Connector (5mm Length) B-02-VBC-3021 x 2



Suspension Arm Spacer T2 A-03-VBC-0052 x 2



M2x10 Shaft Pin B-02-VBC-0020 x 1



Center Drive Shaft B-02-VBC-2017 x 1



Axle Lock Spring B-02-VBC-0027 x 2

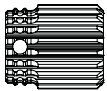

20T Aluminium Top Shaft Gear B-02-P21340 x 1



4x10x3mm Bearing C-02-P21404 x 1



5x10x3mm Bearing C-02-BB-1005-30 x 1



27T Aluminium Idler Gear B-02-P21339 x 1



Gear Spacer B-02-P21342 x 1



5x10mm Ball Bearings C-02-BB-1005-P x 2



Gear Post B-02-P21341 x 1

M3x8 Roundhead C-02-SC-R0308 x 2

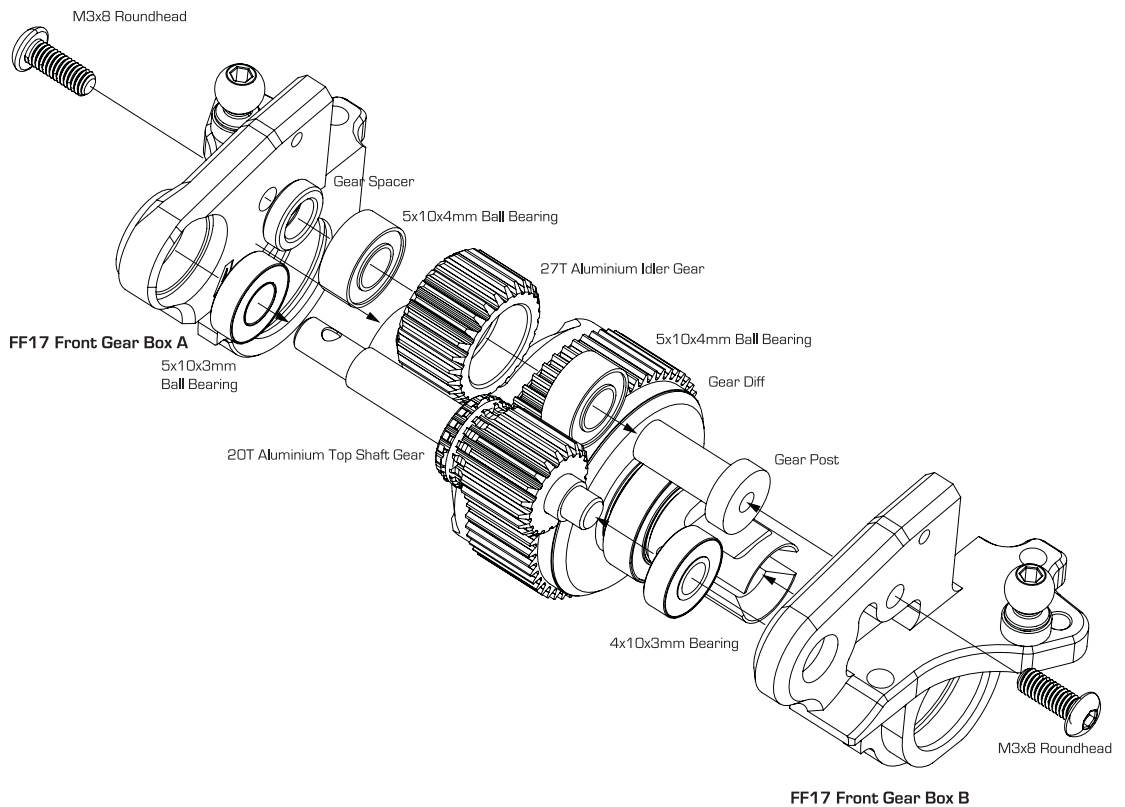
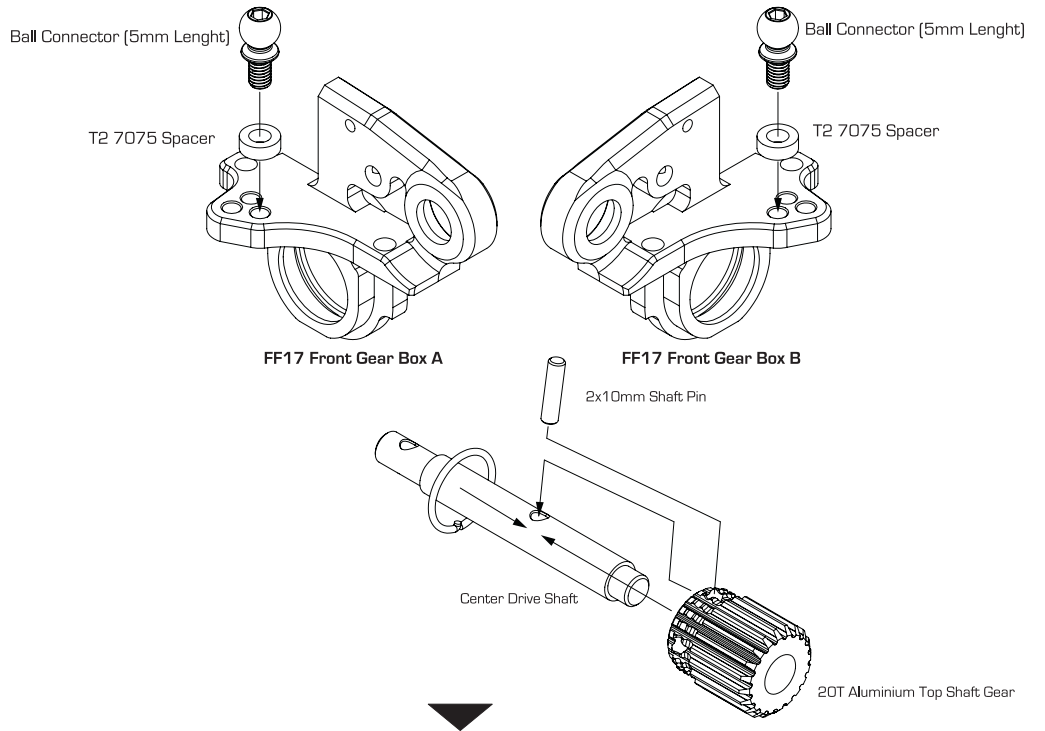

8

Front Damper Stay Assembly



M3x8 Flathead C-02-SC-F0308 x 4



M3x8 Roundhead C-02-SC-R0308 x 3

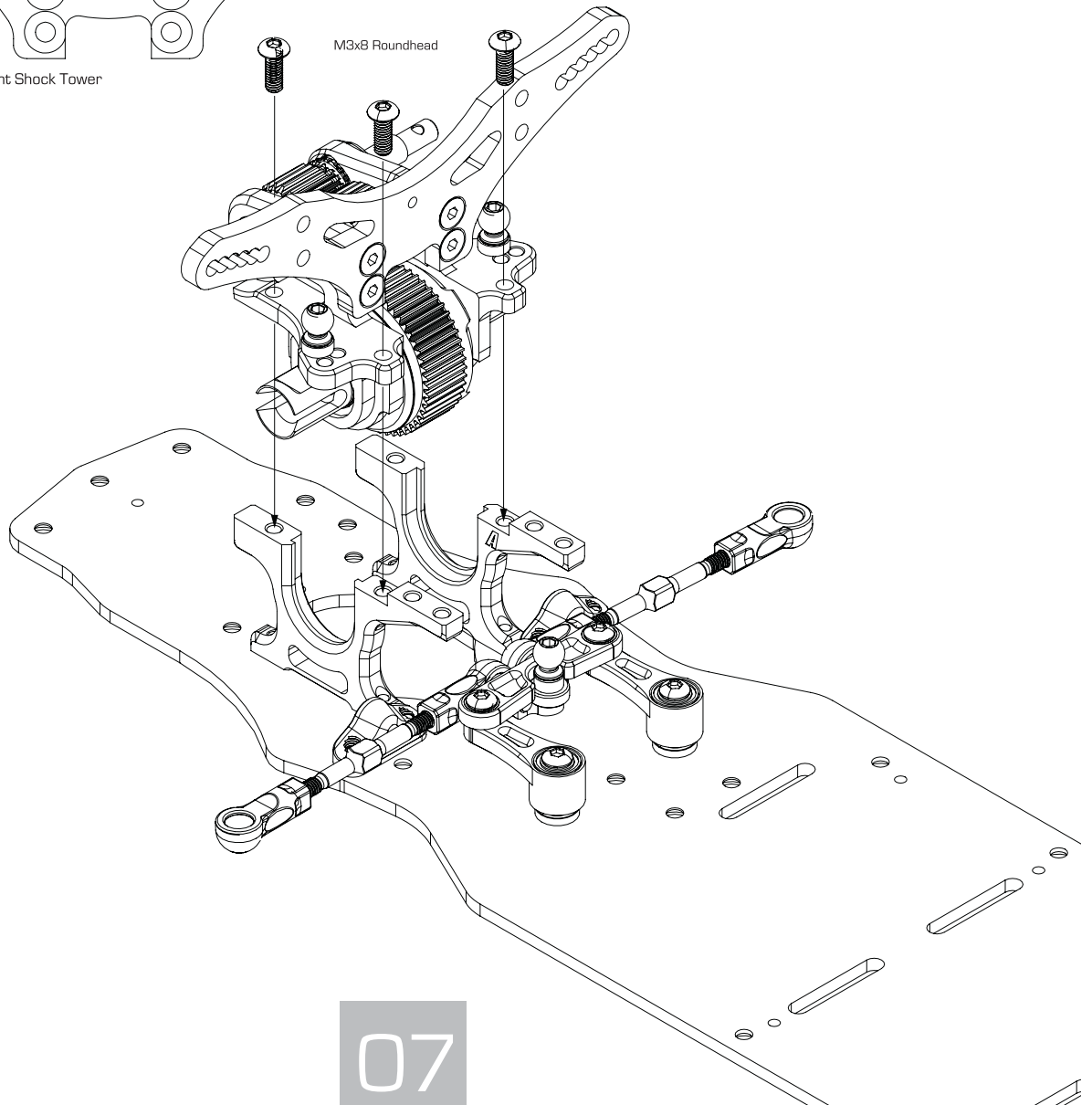
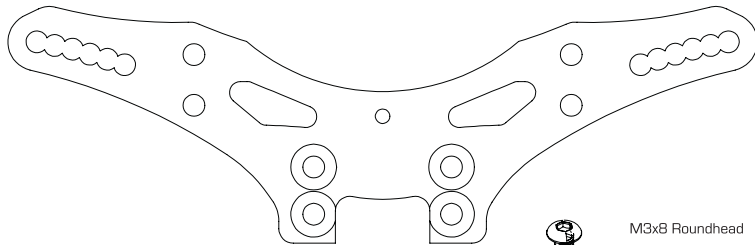
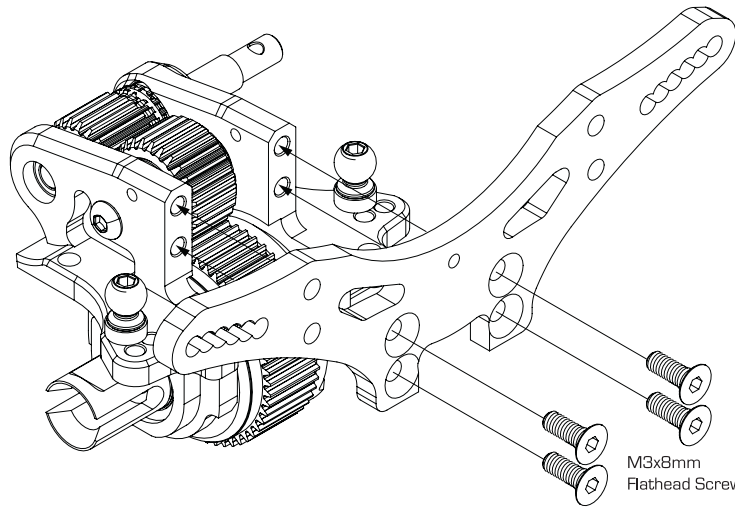

9

Upper Bulkhead And Rear Damper Stay Assembly

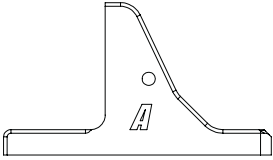

Rear Upper Bulkhead Set (A)
B-02-VBC-2025 x 1

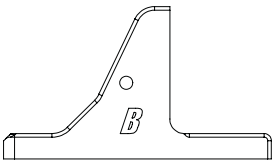

Rear Upper Bulkhead Set (B)
B-02-VBC-2026 x 1

Upper Bulkhead Assembly

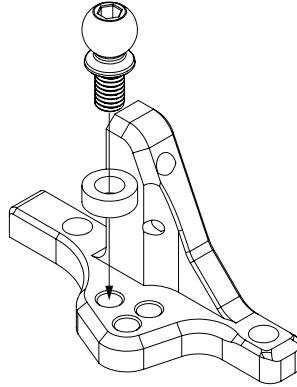

Upper Bulkhead B

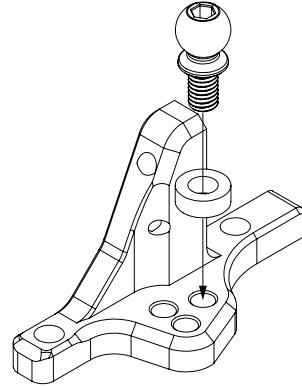

Upper Bulkhead A



T2 7075 Spacer (Red) B-02-P30890 x 2



Ball Connector (5mm Length) B-02-VBC-3021 x 2



Rear Damper Stay Assembly

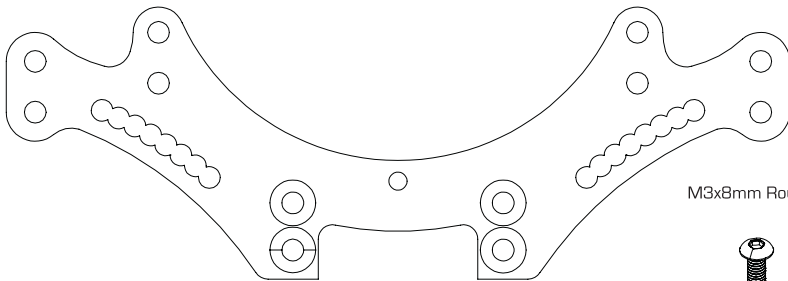

FF17 Graphite Rear Shock Tower A-01-P21378 x 1

M3x8mm Roundhead Screw



M3x8 Flathead C-02-SC-F0308 x 4



M3x8 Roundhead C-02-SC-R0308 x 4

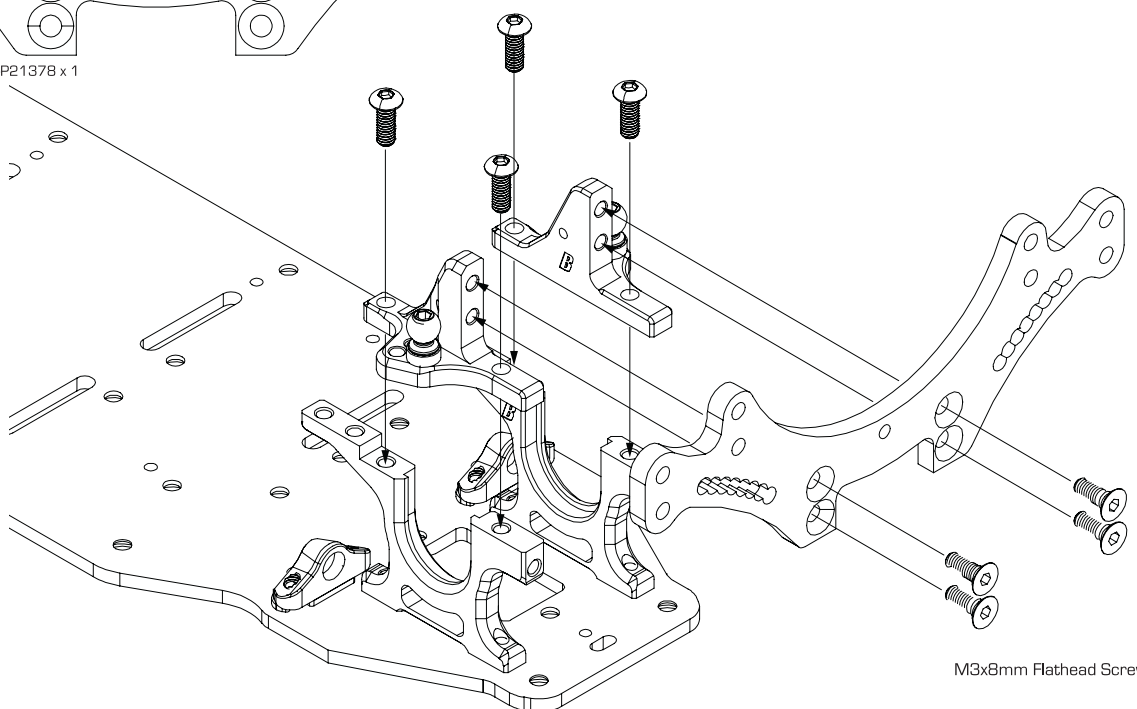

M3x8mm Flathead Screw

10

Rear Suspension Arm Assembly

- Ball Connector B-02-VBC-0045 x 4
- M3x10 Set Screw C-02-SC-SS-0310 x 4
- M4x10 Set Screw C-02-SC-SS-0410 x 4

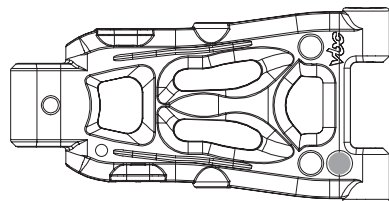

R Suspension Arm Composite X Silver A-03-P30896 x 2

- Suspension Arm Spacer T2 Composite A-03-VBC-0052 x 2

- Suspension Arm Spacer T1 Composite A-03-VBC-0051 x 4

- Suspension Arm Pin B-02-VBC-0029 x 2

- Arm Pin Pivot Ball B-02-VBC-0035 x 4

- 1mm Suspension Shim A-01-VBC-0037 x 1

- M3x6 Flat Head Screw C-02-SC-F0306 x 2

- E30 Suspension Mount B-02-VBC-0061-30 x 1

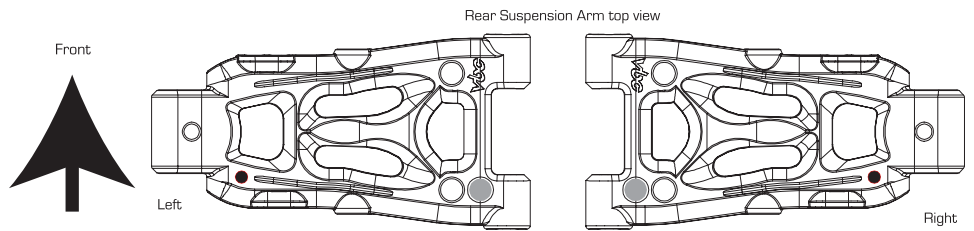

Make sure the black markings are in the same direction on the left and right suspension arms

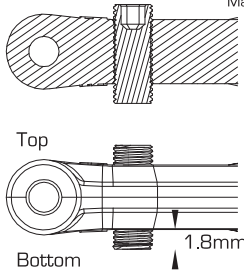

Insert M4x10 Set Screw from the top of the suspension arm for adjusting down stop. Initial setting is 1.8mm measuring from the bottom part of the arm for both sides.

TIP Suspension Arm Composite Compound Chart

Silver A-03-G30896	Gold A-03-P30930	Red A-03-G31300
Medium	Hard	Ultra Hard

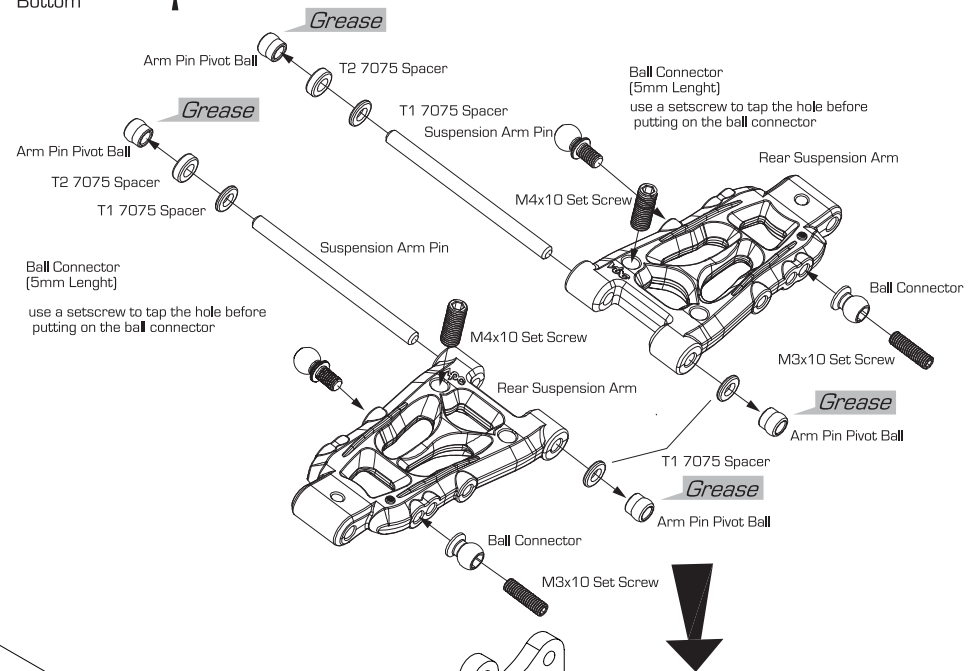

After installing the rear arms, make sure the arms can move freely

09

Rear Suspension Upright Assembly

11

Rear Suspension Arm Assembly

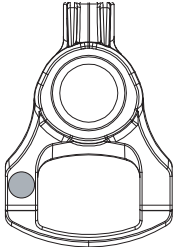

R 2-hole Upright Composite X Sliver A-03-P31327 x 2

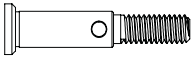

Rear Wheel Axle B-02-VBC-2027 x 2



5x10mm Ball Bearings
C-02-BB-1005-B x 4



Ball Connector (7.5mm Length)
B-02-VBC-3022 x 2



T2 7075 Spacer B-02-VBC-0019-20 x 2



Lightweight 0 Offset Hex Wheel Hub B-02-P30887 x 2



M3x3 Set Screw C-02-SC-SS-0303



M2x10 Shaft Pin B-02-VBC-0020 x 2



M3x32mm Turnbuckle B-02-VBC-0036 x 2



Turnbuckle Cup A-03-VBC-0039 x 4



M3x23 Upright Pin B-02-VBC-0032 x 2



3x5x0.3mm Shim B-02-VBC-0101 x 2



M3x6 Set Screw C-02-SC-SS-0306 x 2

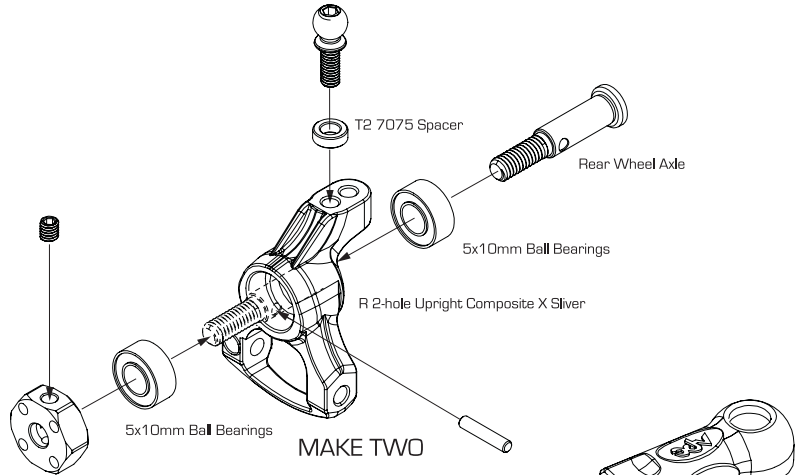

Rear Upper Linkage

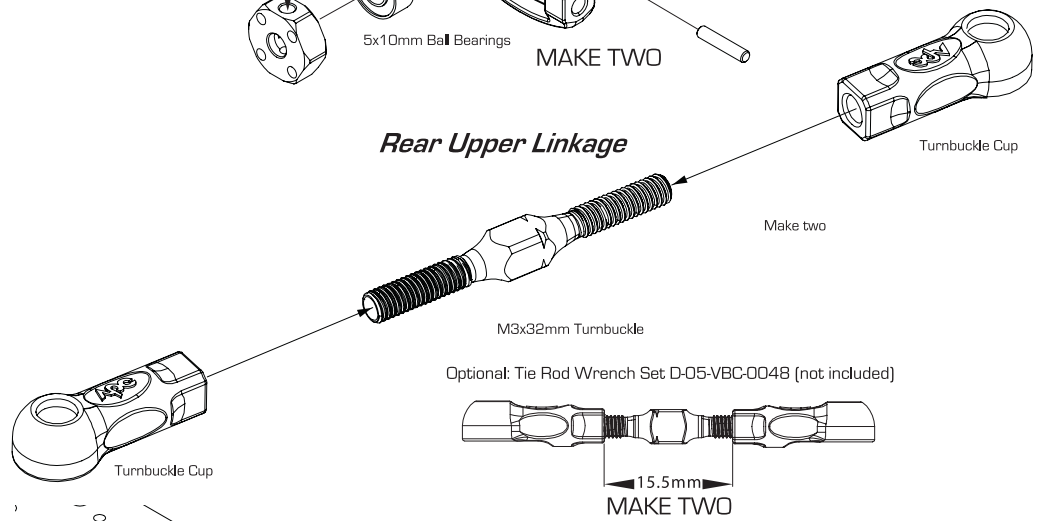

Rear Suspension Arm Assembly

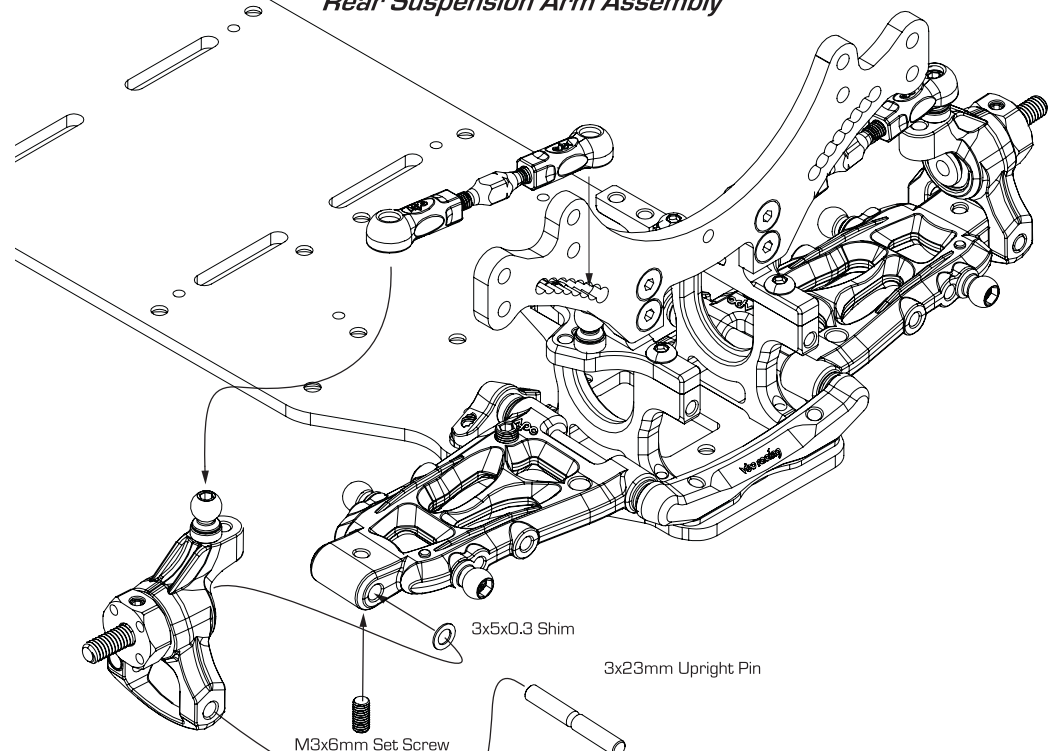

10

Front Suspension Arms top view

12

Front Suspension Arm Assembly

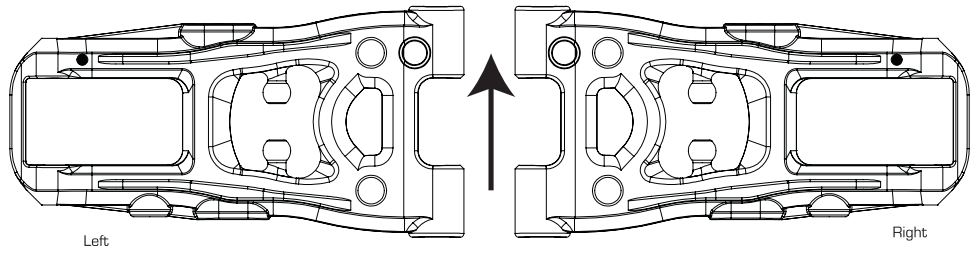

Make sure the black markings are in the same direction on the left and right suspension arms

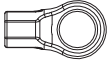

Turnbuckle Cup Open Type L A-03-VBC-0041 x 2

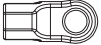

Turnbuckle Cup Open Type S A-03-VBC-0040 x 2



Suspension Arm Spacer T1 A-03-VBC-0051 x 2



Suspension Arm Spacer T2 A-03-VBC-0052 x 2



Arm Pin Pivot Ball B-02-VBC-0035 x 4

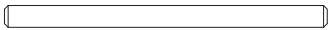

Suspension Arm Pin B-02-VBC-0029 x 2

TIP Suspension Arm Composite Compound Chart

F Suspension Arm Composite X Silver A-03-P30899	F Suspension Arm Composite X Gold A-03-P30929	F Suspension Arm Composite X Red A-03-G31299
Medium	Hard	Ultra-Hard

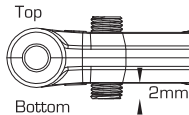
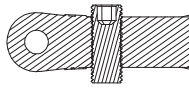

Insert M4x10 set screw from the top of the suspension arm for adjusting down stop. Initial setting is 2mm measuring from the bottom part of the arm for both sides.

Front Anti-Roll Bar Connector

Ball Connector Open Type S

Ball Connector Open Type L

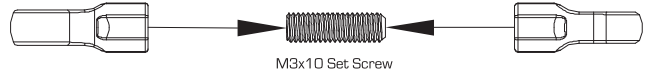

M3x10 Set Screw

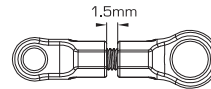

MAKE TWO

F Suspension Arm Composite X Silver A-03-P30899



Ball Connector B-02-VBC-0045 x 2

M3x10 Set Screw C-02-SC-SS-0310 x 4

M4x10 Set Screw C-02-SC-SS-0410 x 2

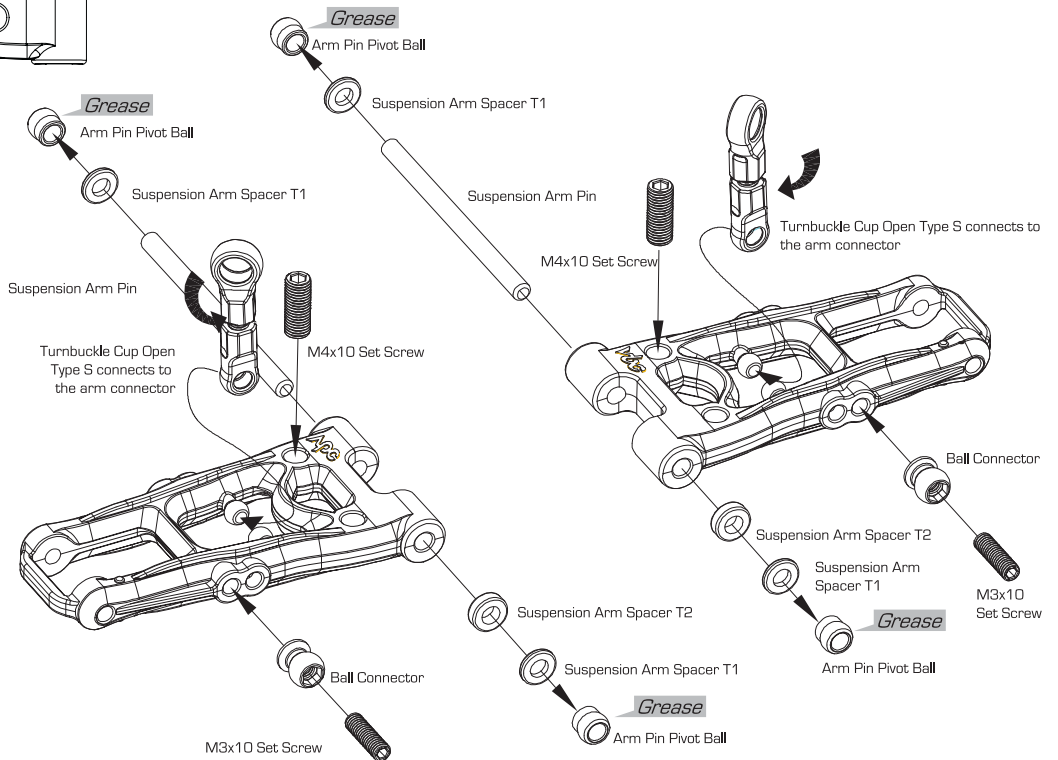

13

Front Suspension Arm Assembly



F00 Suspension Mount B-02-VBC-0060-00 x 1



1mm Suspension Shim A-01-VBC-0037 x 1



M3x6 Flat Head Screw C-02-SC-F0306 x 2

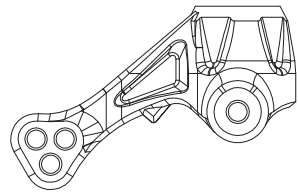

Steering Block Composite X Sliver A-03-P30898 x 2

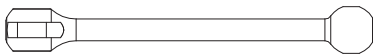

Inner Axle B-02-VBC-0024 x 2

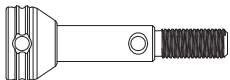

Wheel Axle B-02-VBC-0025 x 2



Axle Joint B-02-VBC-0026 x 2



Axle Lock Spring B-02-VBC-0027 x 2



5x10mm Ball Bearing C-02-BB-1005-B x 4



M2x12 Shaft Pin B-02-VBC-0022 x 2



M2x10 Shaft Pin B-02-VBC-0020 x 2



Shaft End Shoe A-03-VBC-0038 x 2



M3x2 Set Screw C-02-SC-SS-0302 x 2



Lightweight O Offset Hex Wheel Hub B-02-P30887 x 2



M3x3 Set Screw C-02-SC-SS-0303

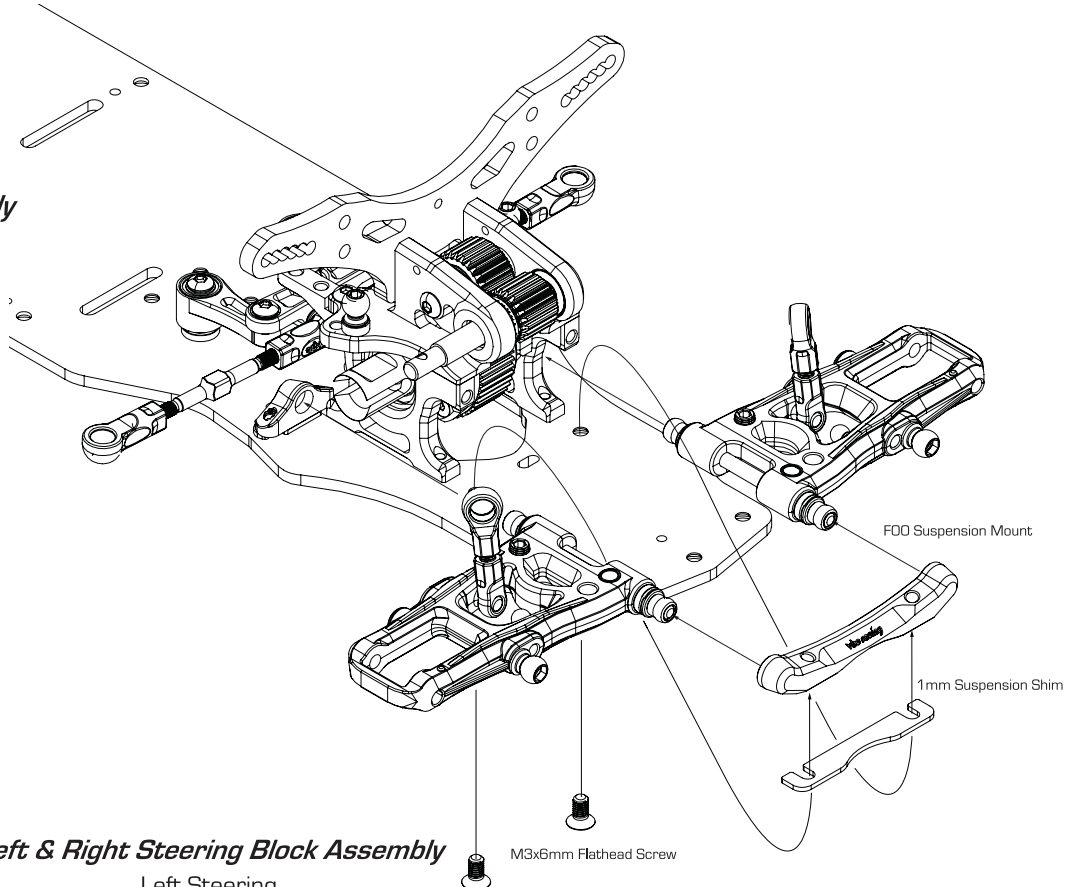

Left & Right Steering Block Assembly

Left Steering

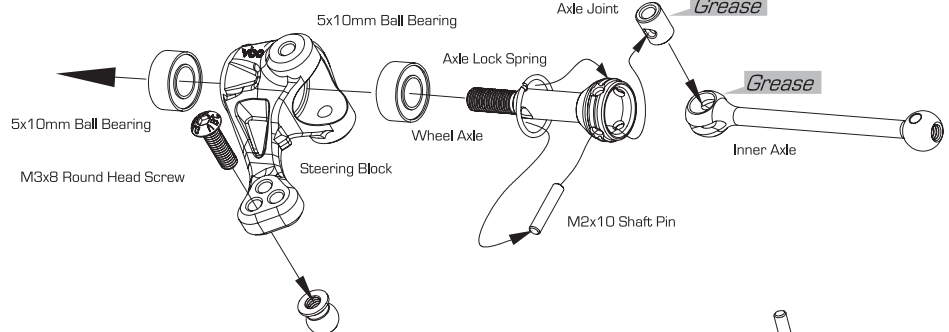

Joint cross section

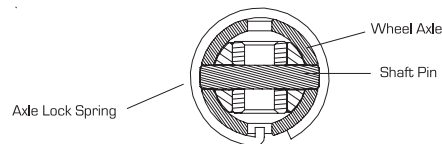

Make sure the Axle Lock Spring is place correctly onto the Wheel Axle

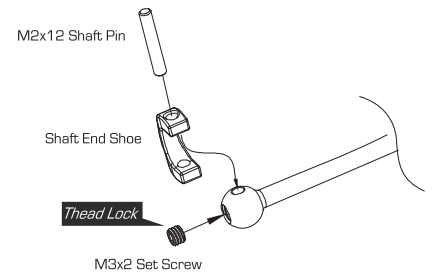

Ball Connector B-02-VBC-0045 x 2



M3x8 Round Head Screw C-02-SC-R0308 x 2

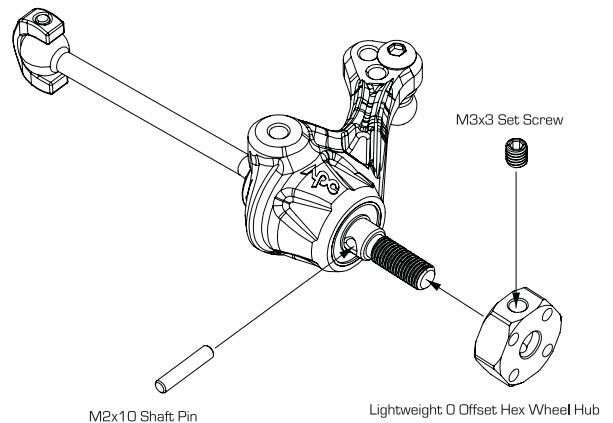

12

13

Front Suspension Arm Assembly

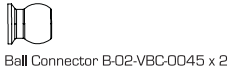
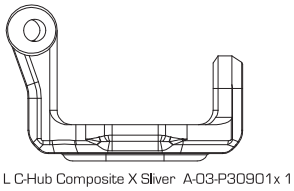
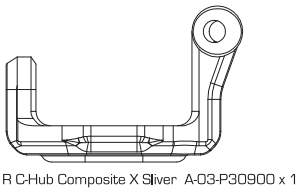
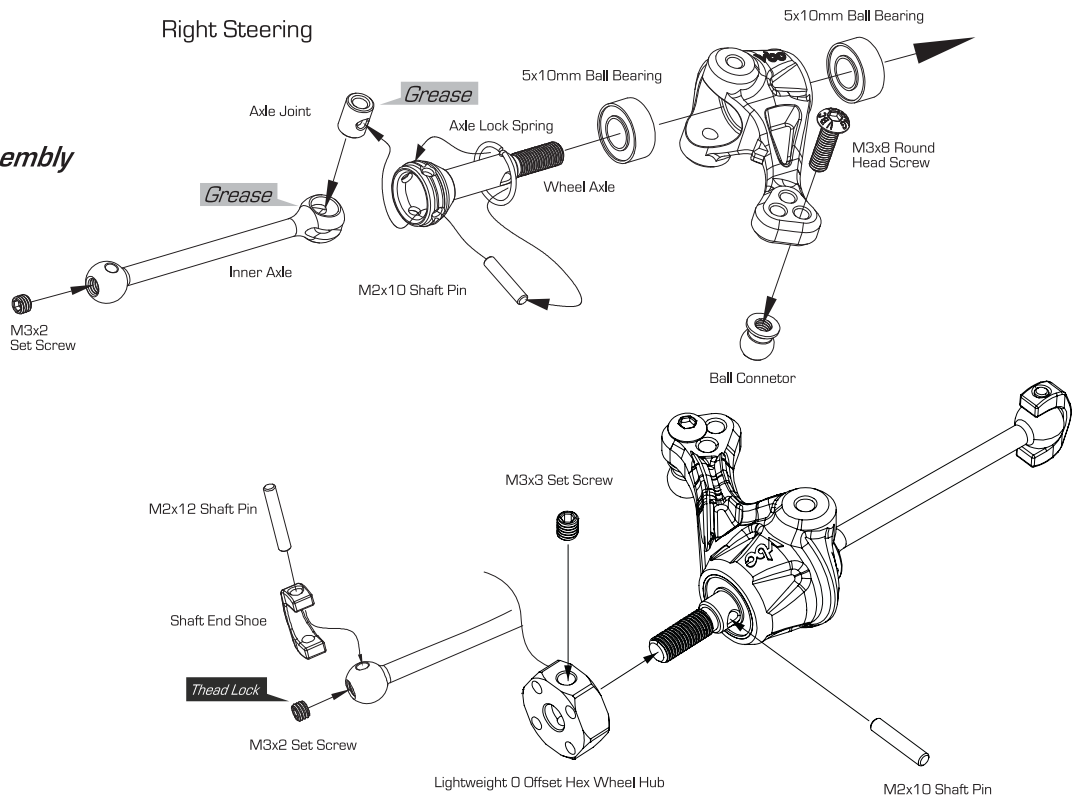

Left & Right C-Hub Assembly

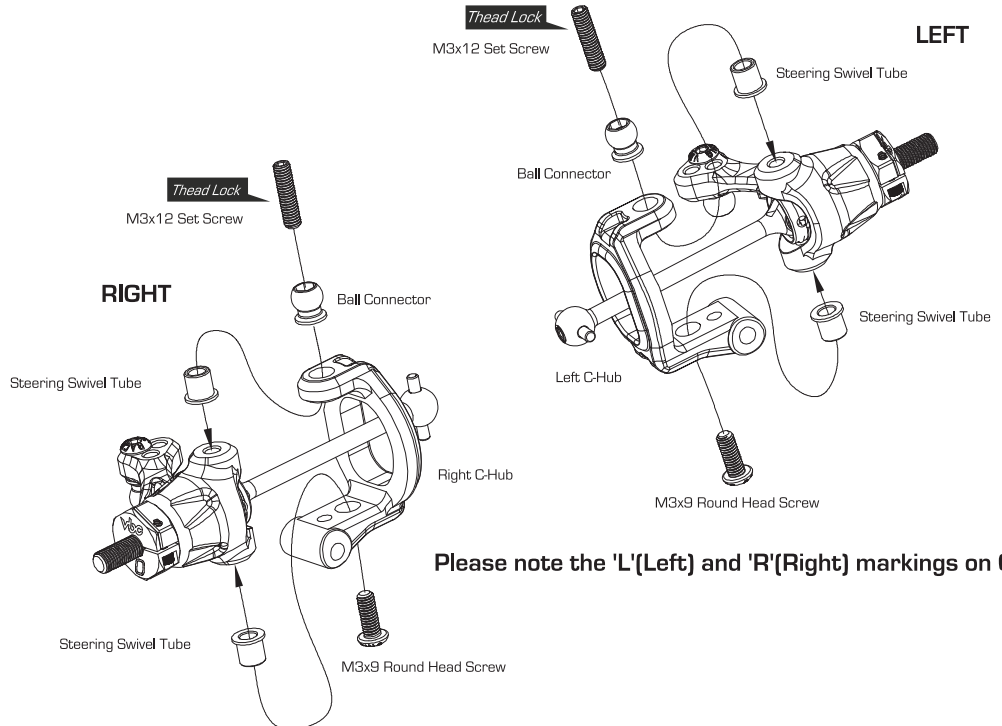

Please note the 'L'(Left) and 'R'(Right) markings on C-Hubs