

# GOOSE

New Generation Rear Wheel Drive

ABC HOBBY ORIGINAL RADIO CONTROL CAR

## Instruction Manual

Study the instructions thoroughly  
before assembly.

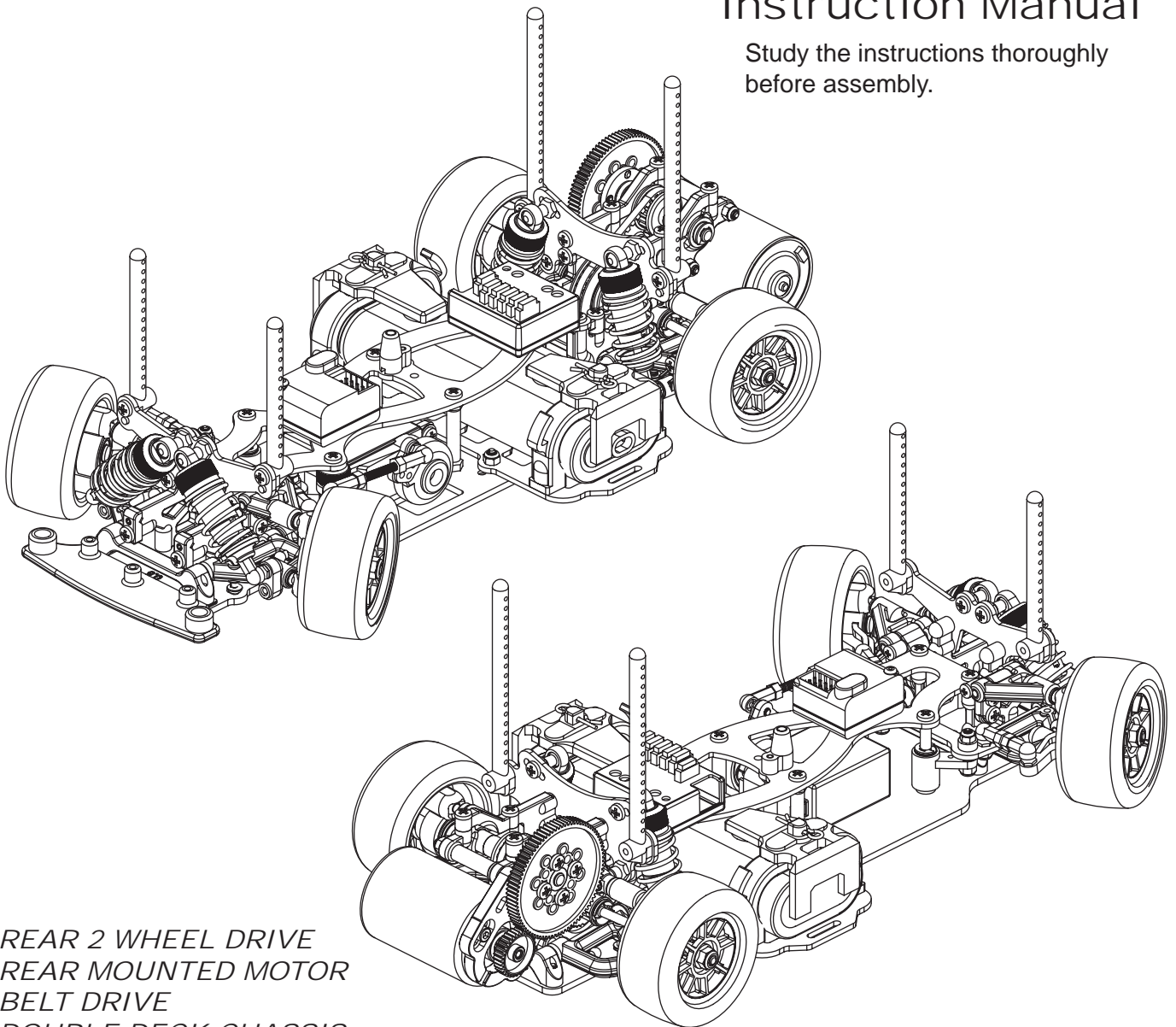

- REAR 2 WHEEL DRIVE
- REAR MOUNTED MOTOR
- BELT DRIVE
- DOUBLE DECK CHASSIS
- BALL DIFFERENTIAL
- FULL ADJUSTABLE SUSPENSION
- WHEEL BASE: 210mm
- BODY WIDTH: 157mm-163mm
- ROAD CLEARANCE: 4-10mm

# 1 DIFFERENTIAL

- Cap Screw (2.5mmx25mm)
- Diff Ball (1/8")
- Thrust Washer
- Thrust Ball (1/16")
- 850 Bearing
- Diff Ring
- Diff Spring
- Nylon Nut (2.5mm)
- 1510 Bearing
- Diff Joint Ring

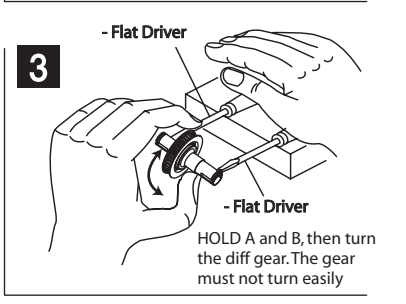
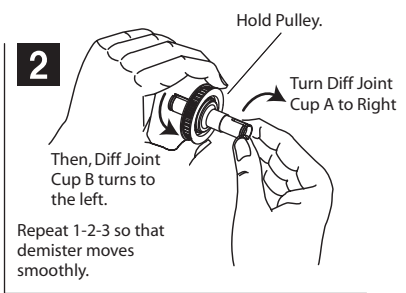
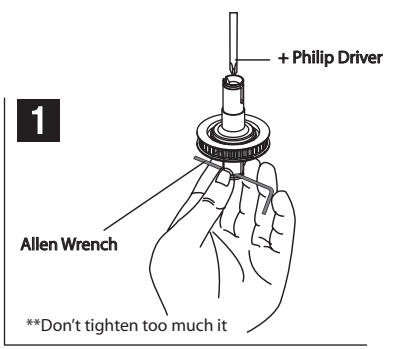
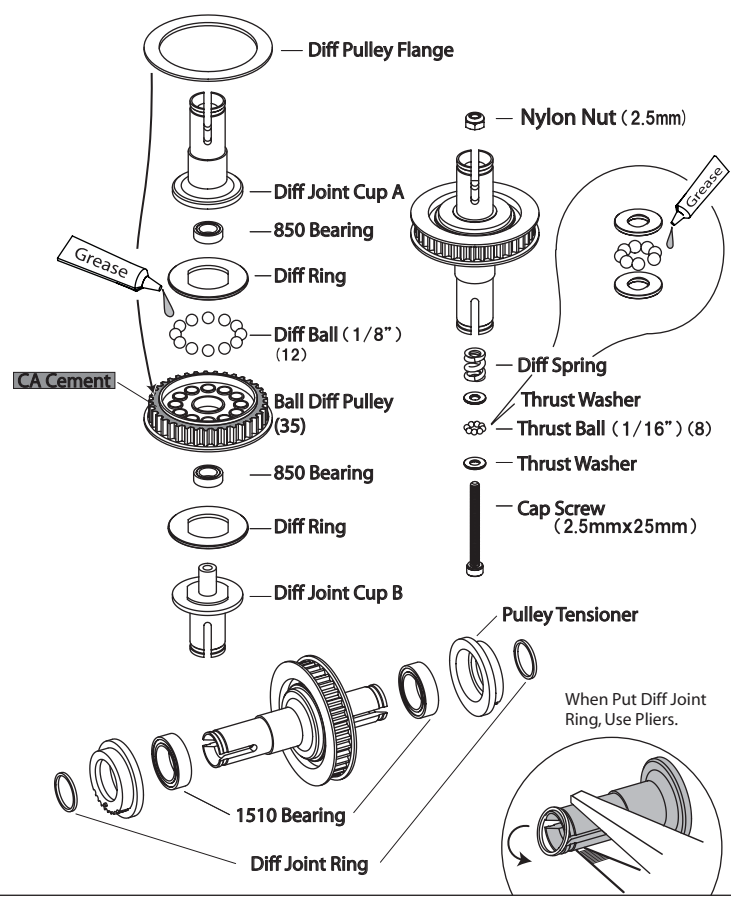

# 2 STEERING COMPONENT

- Ball Stud 4mm
- Steering Shaft
- 3mm E Clip
- Nylon Nut (2.5mm)
- Nylon Nut (3mm)
- Nut (3mm)

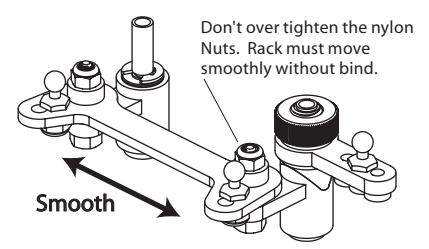
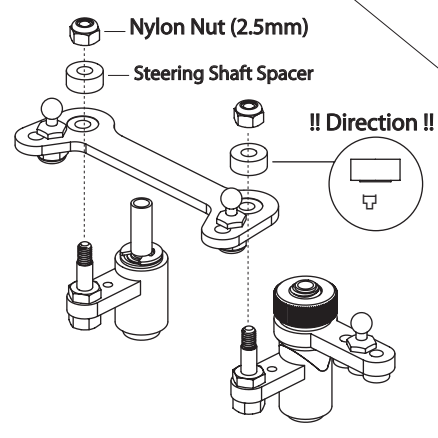
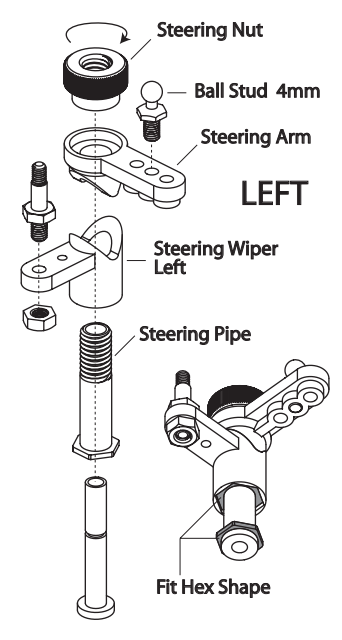
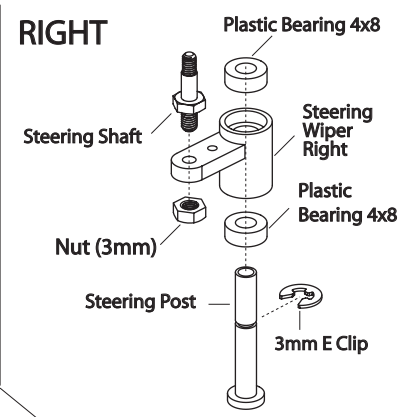
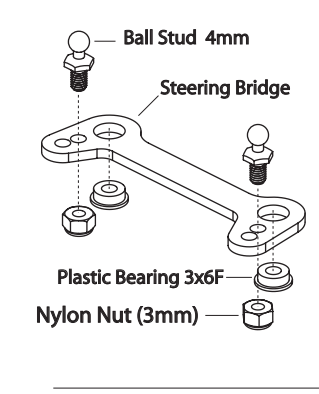

# 3 STEERING / ROWER ARM



3X10mm Flat Head Screw



3x8mm Hex Cap Screw



3x8mm Button Head Screw



4mm Ball Stud





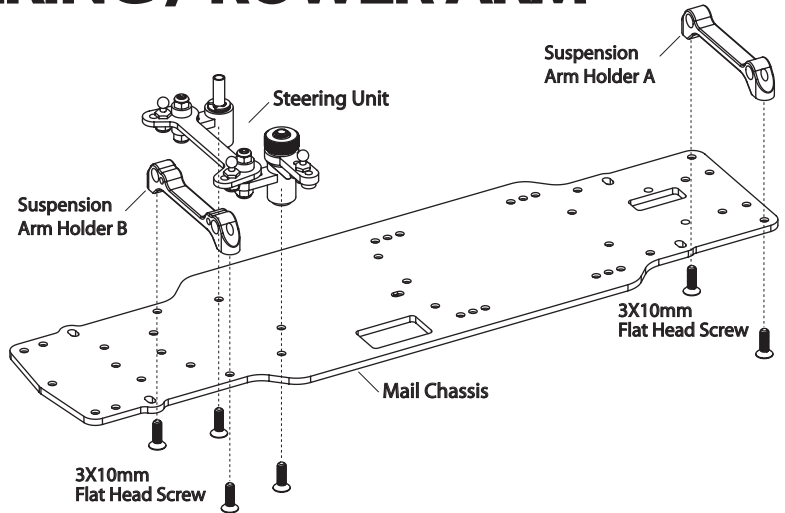



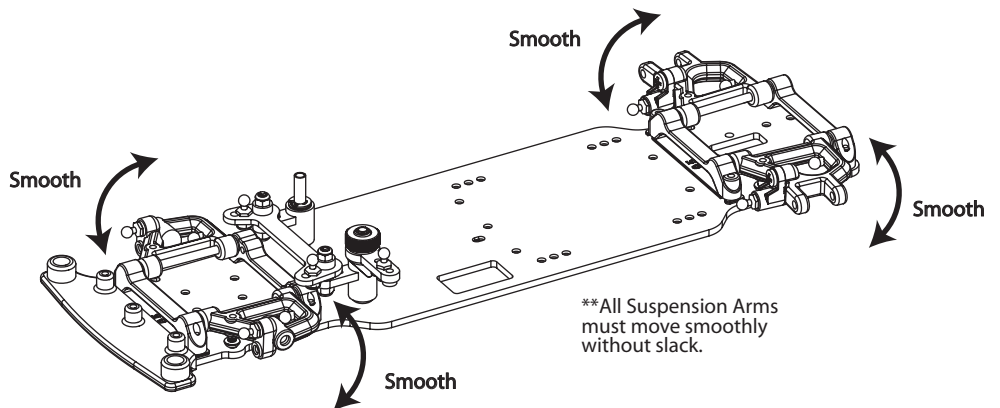
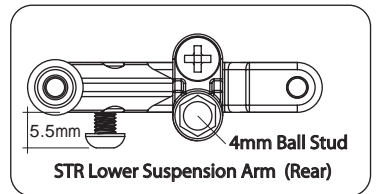
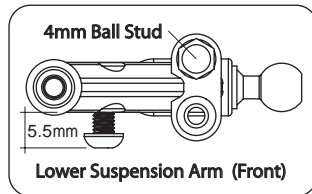
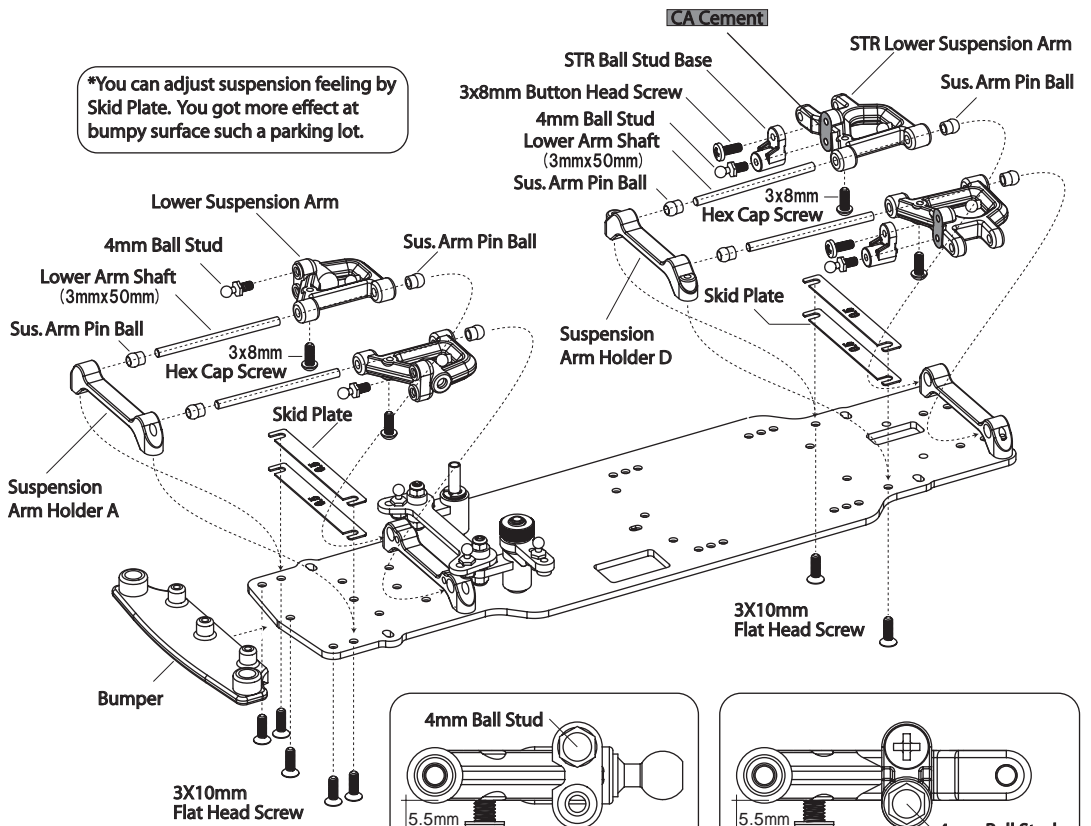

Lower Arm Shaft (3mmx50mm)



\*You can adjust suspension feeling by Skid Plate. You got more effect at bumpy surface such a parking lot.



-  2.6X5mm Binding Screw
-  3x8mm Binding Screw
-  3x10mm Binding Screw
-  3X8mm Flat Head Screw
-  3x3mm Set Screw (For Anti-Roll Bar)
-  Ball Stud 6mm
-  Ball Stud 5.8x11mm
-  Upper Suspension Pin (3mm x 24mm)

### Suspension Arm (Front)

For Goose / Genetic

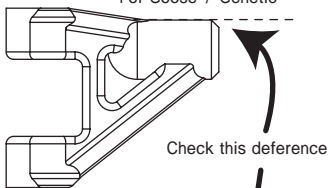

### Suspension Arm (Rear)



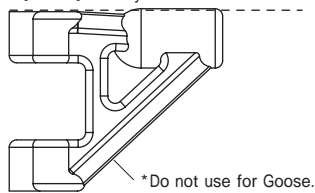

Only for Genetic

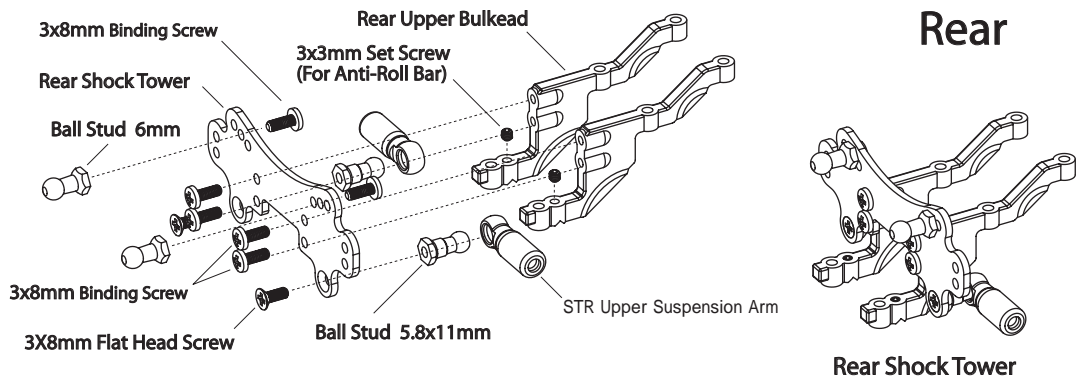
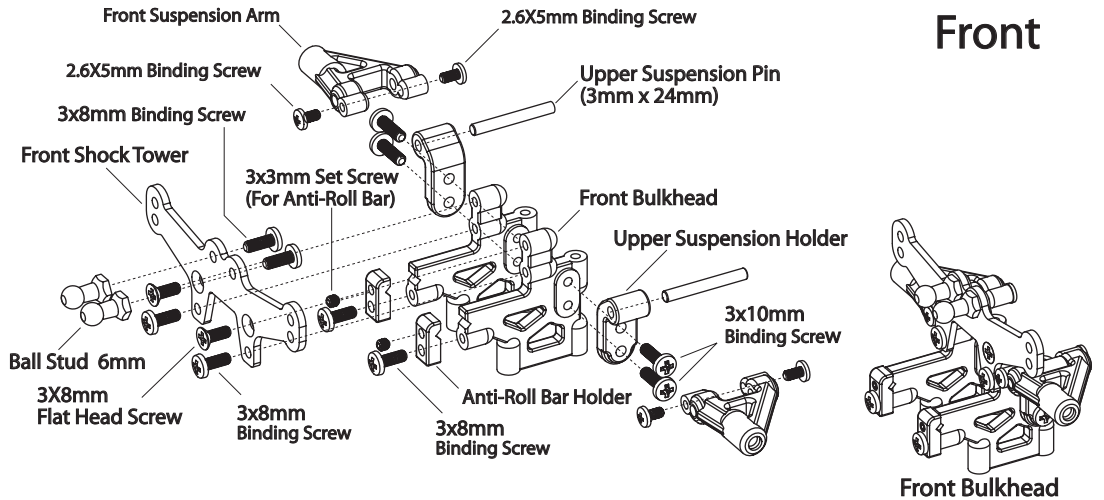

## 4 BULKHEAD / SHOCK TOWER



## 5 CENTER GEAR UNIT

-  3x6mm Binding Screw
-  MF105 Bearing
-  2X7.8mm Pin
-  P8 O Ring
-  4 mm E Clip

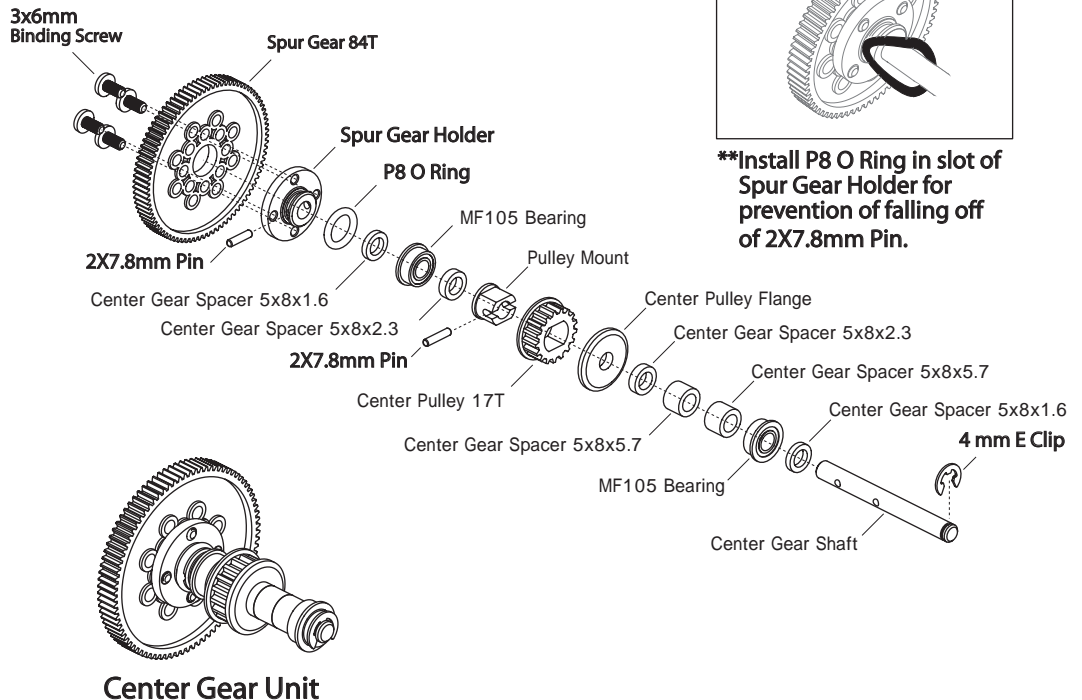



# 6 REAR BULKHEAD

 3X10mm Button Head Screw

 3X40mm Flat Head Screw

 Nylon Nut (3mm)

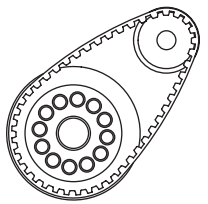

Push the Drive Belt. Best Slackness is 2-3mm. If Belt tension is tight, make a drag, if loose, gear will be skip.

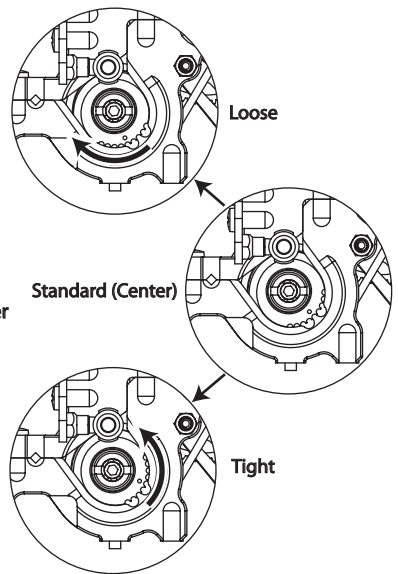
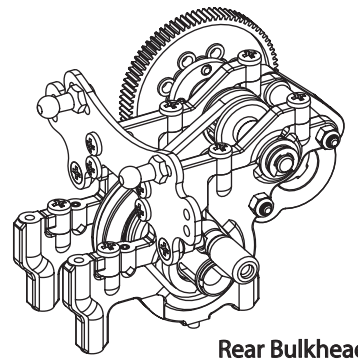
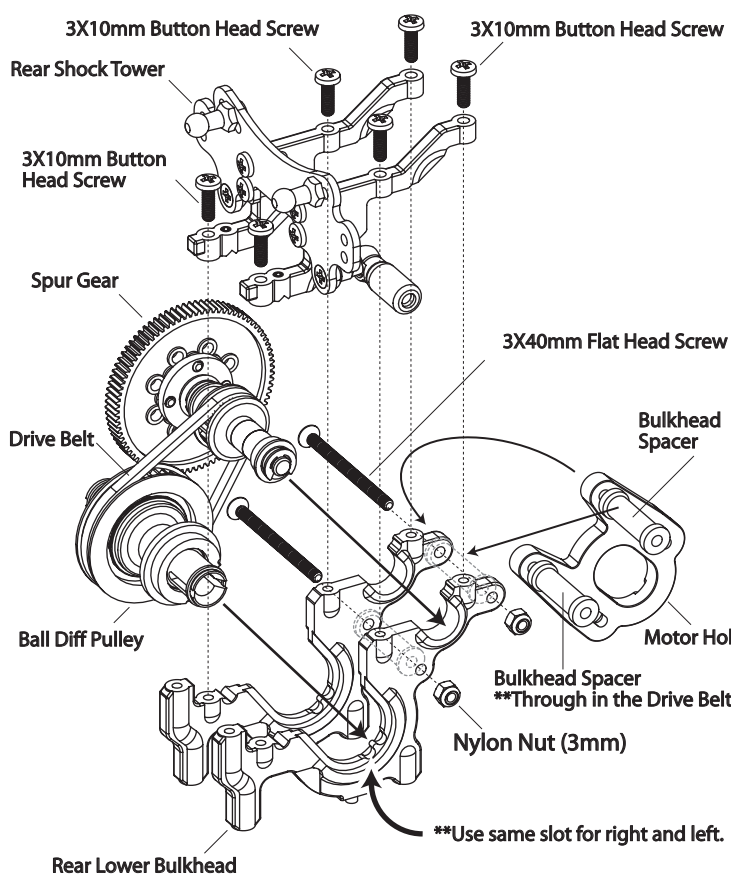
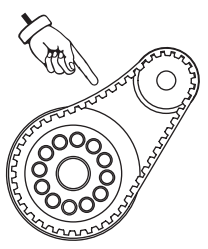





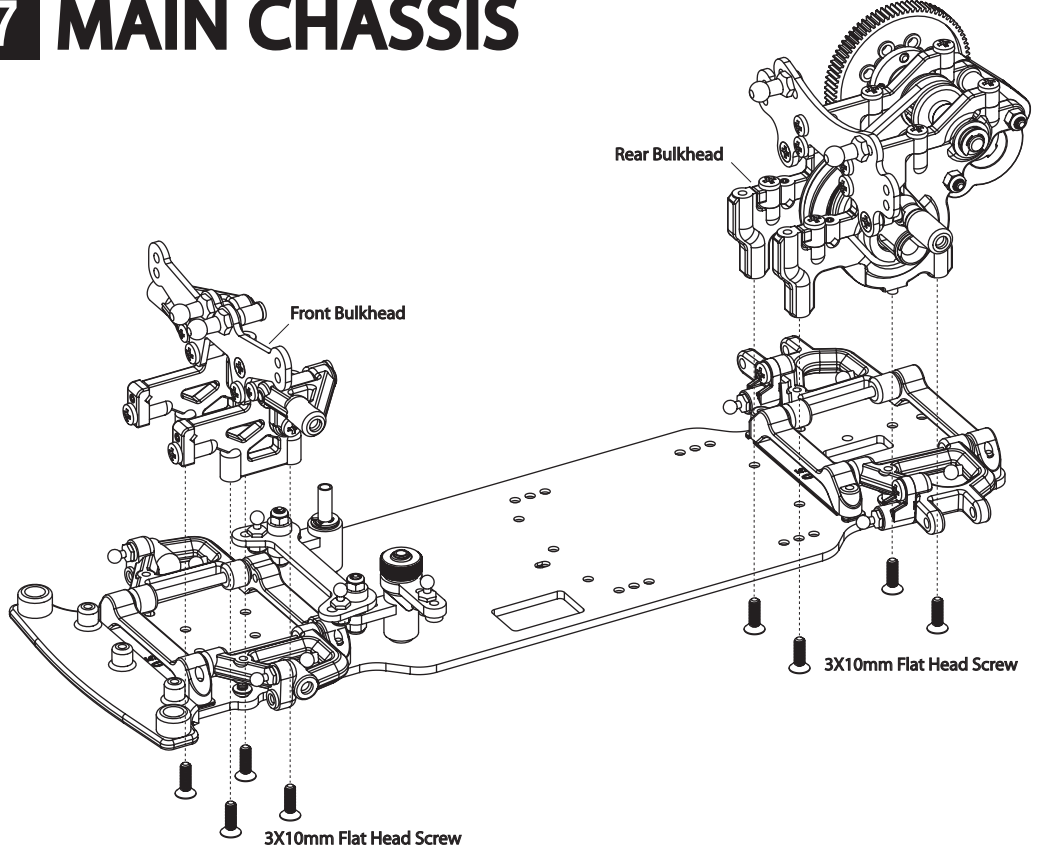

# 7 MAIN CHASSIS

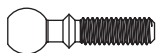

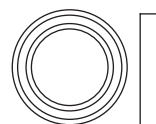

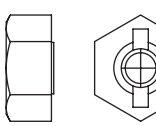
 3X10mm Flat Head Screw

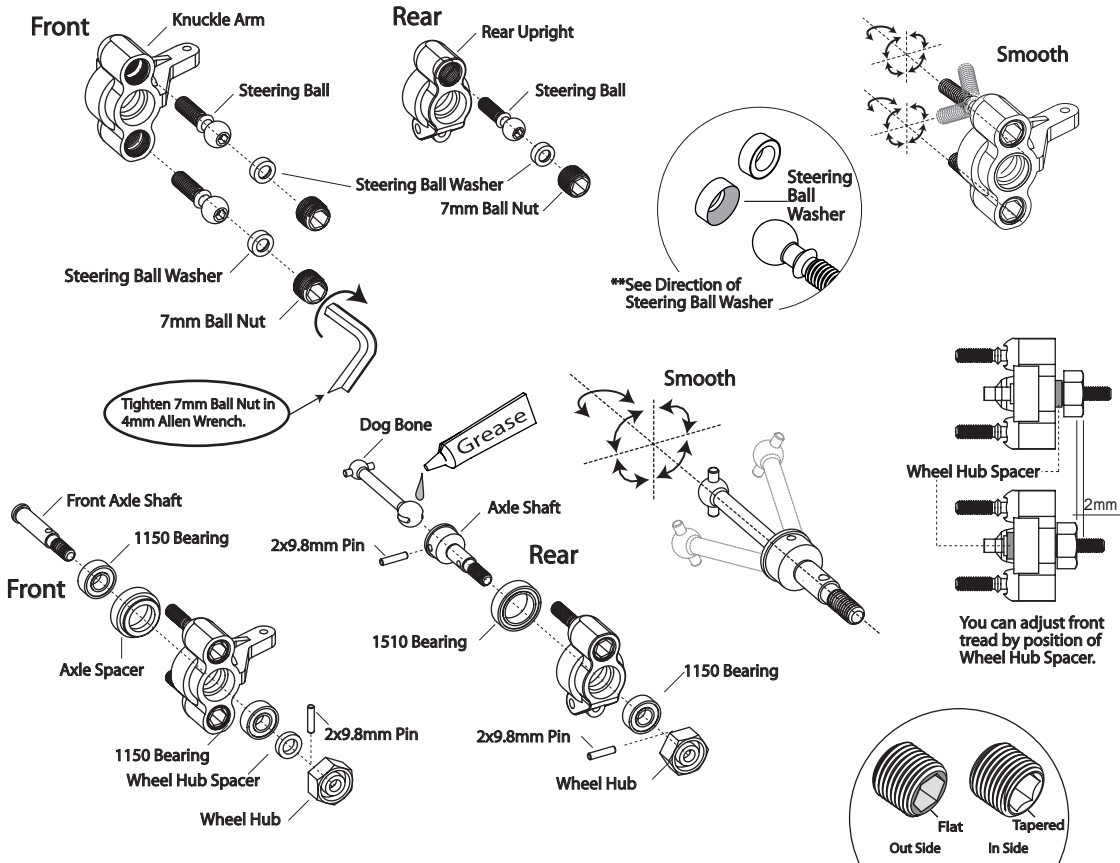

# 8 KNUCKLE ARM/REAR UPRIGHT

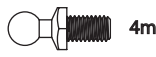
-  Steering Ball
-  Steering Ball Washer
-  7mm Ball Nut
-  1510 Bearing
-  1150 Bearing
-  Wheel Hub
-  2x9.8mm Pin

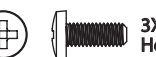

-  4mm Ball Stud
-  3x3mm Set Screw
-  Tapered Spacer (4mmx6mmx0.7t)
-  Aluminum Spacer (4mmx7mmx2t)
-  3X10mm Button Head Screw

# 9 ASSEMBLE SUSPENSION PARTS

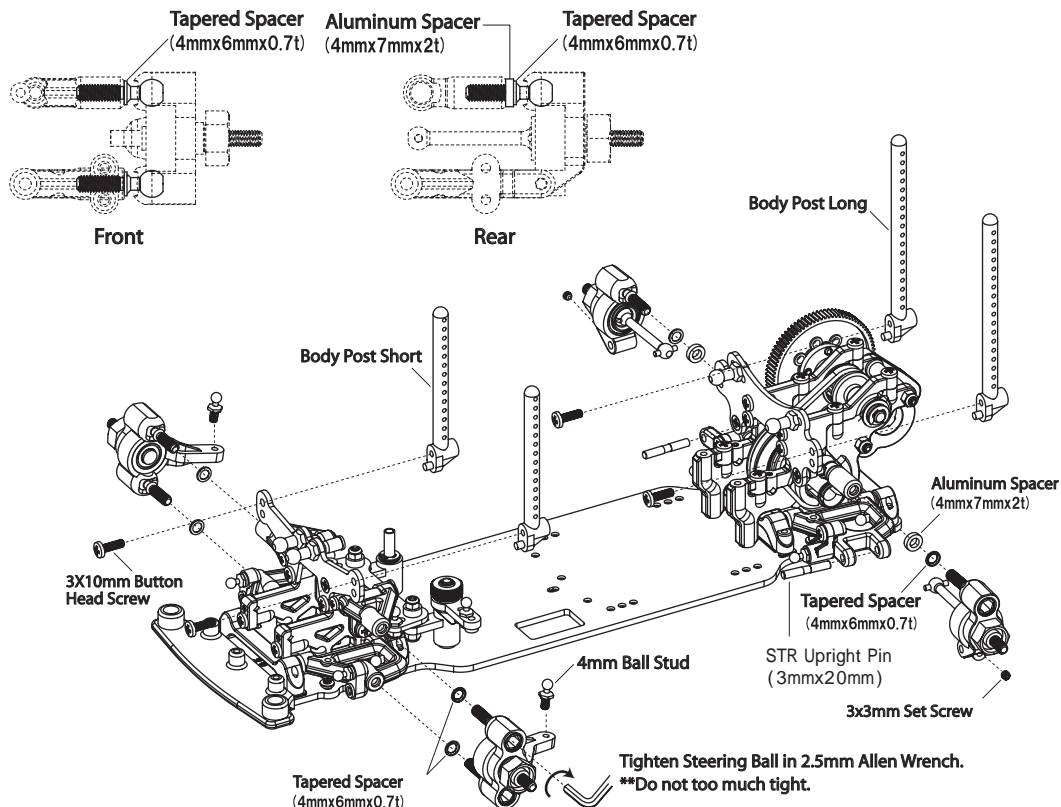

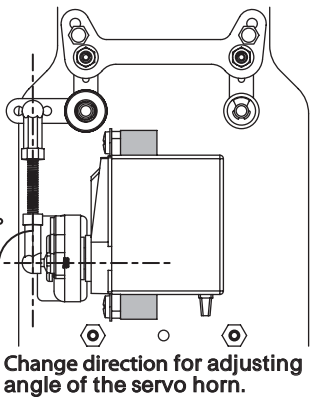
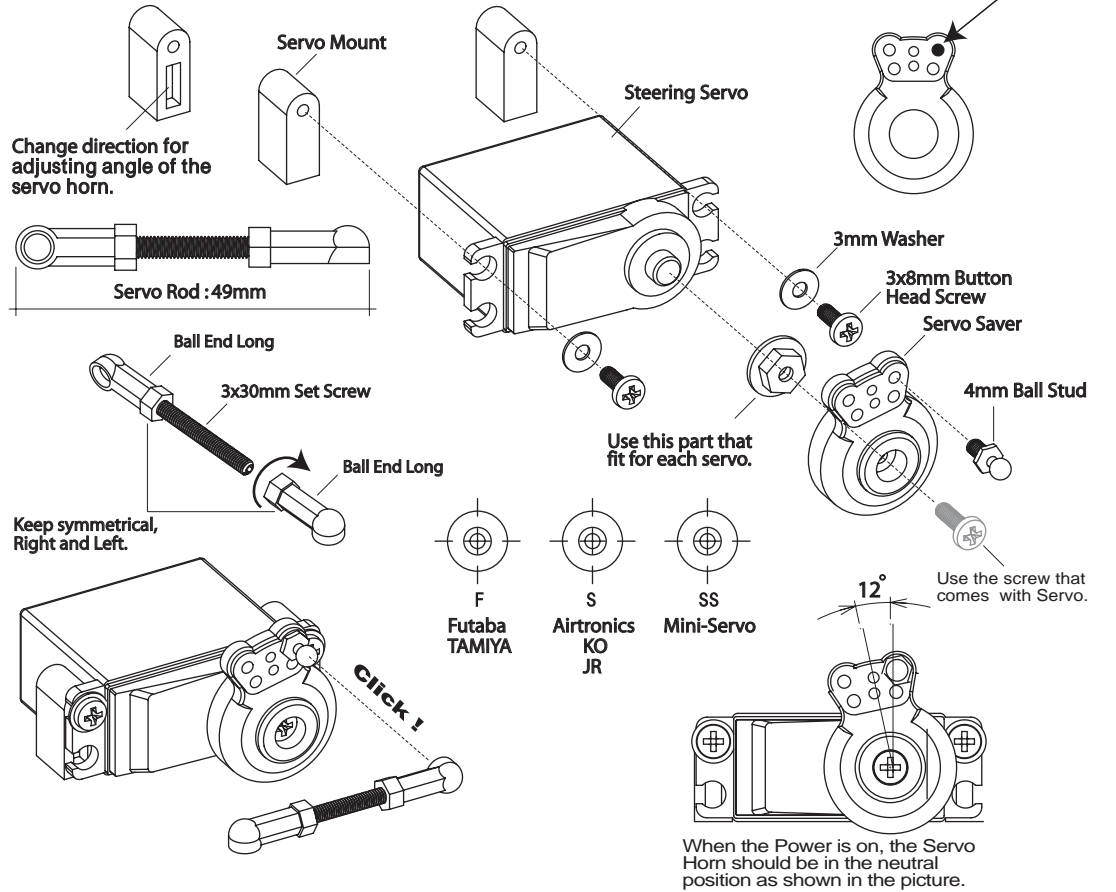
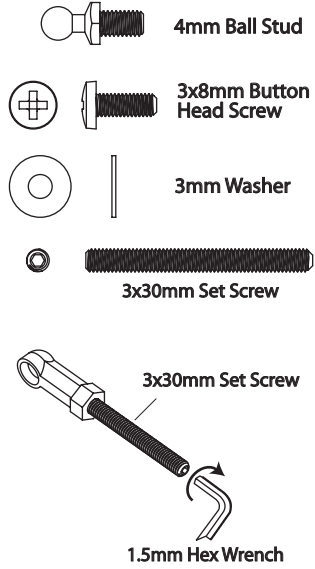

# 10 SERVO SAVER

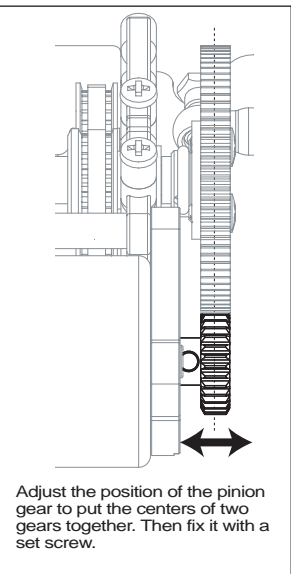
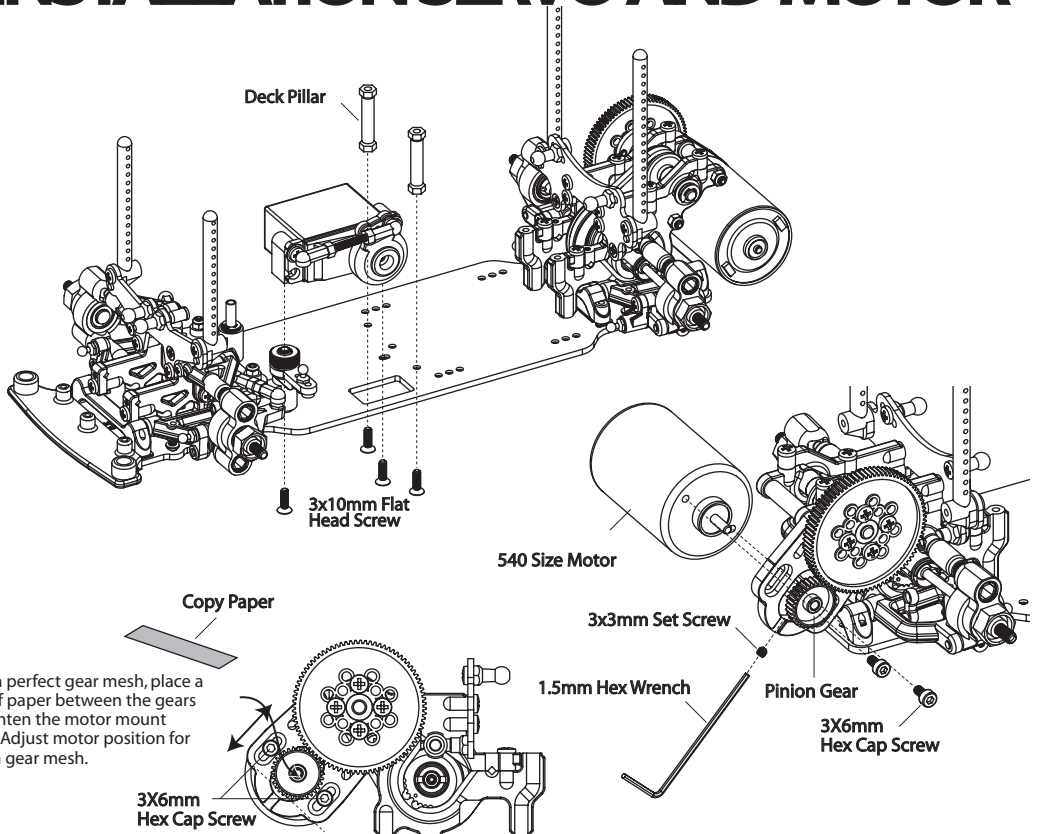

# 11 INSTALLATION SERVO AND MOTOR





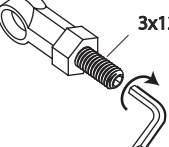

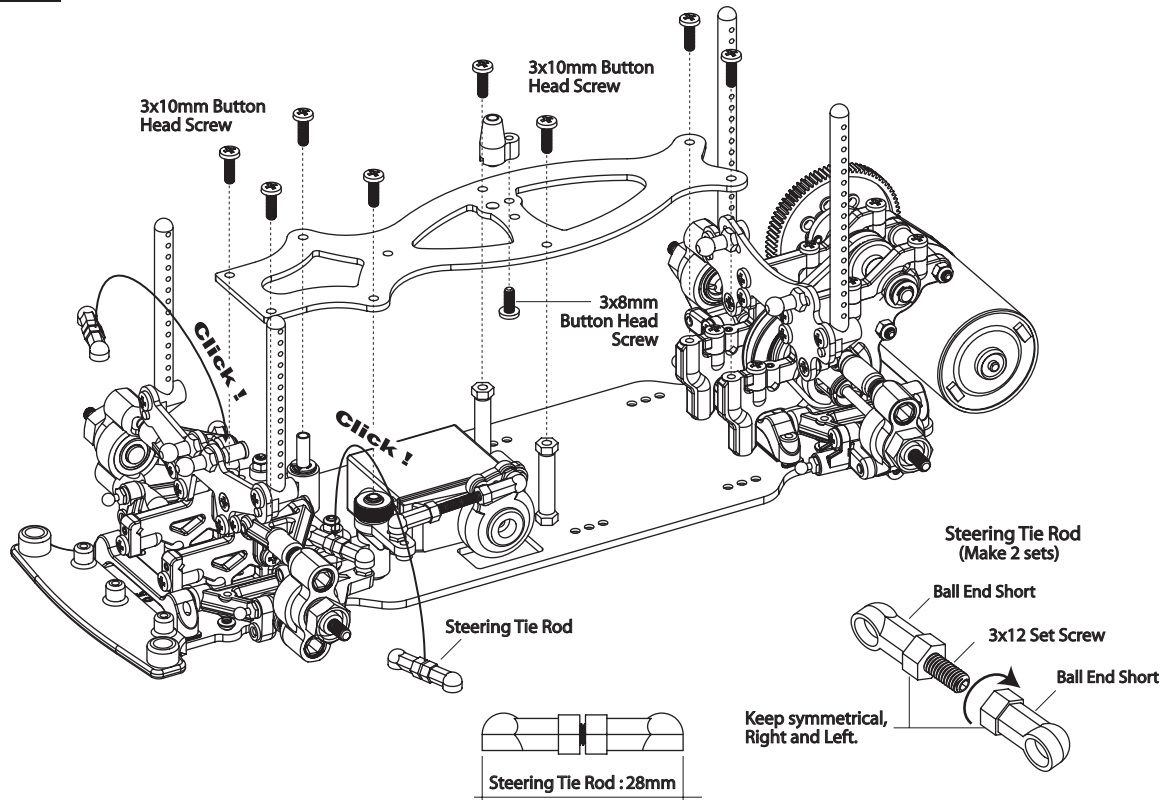
# 12 UPPER DECK

-  3x10mm Button Head Screw
-  3x8mm Button Head Screw
-  3x12 Set Screw
-  3x12 Set Screw  
1.5mm Hex Wrench

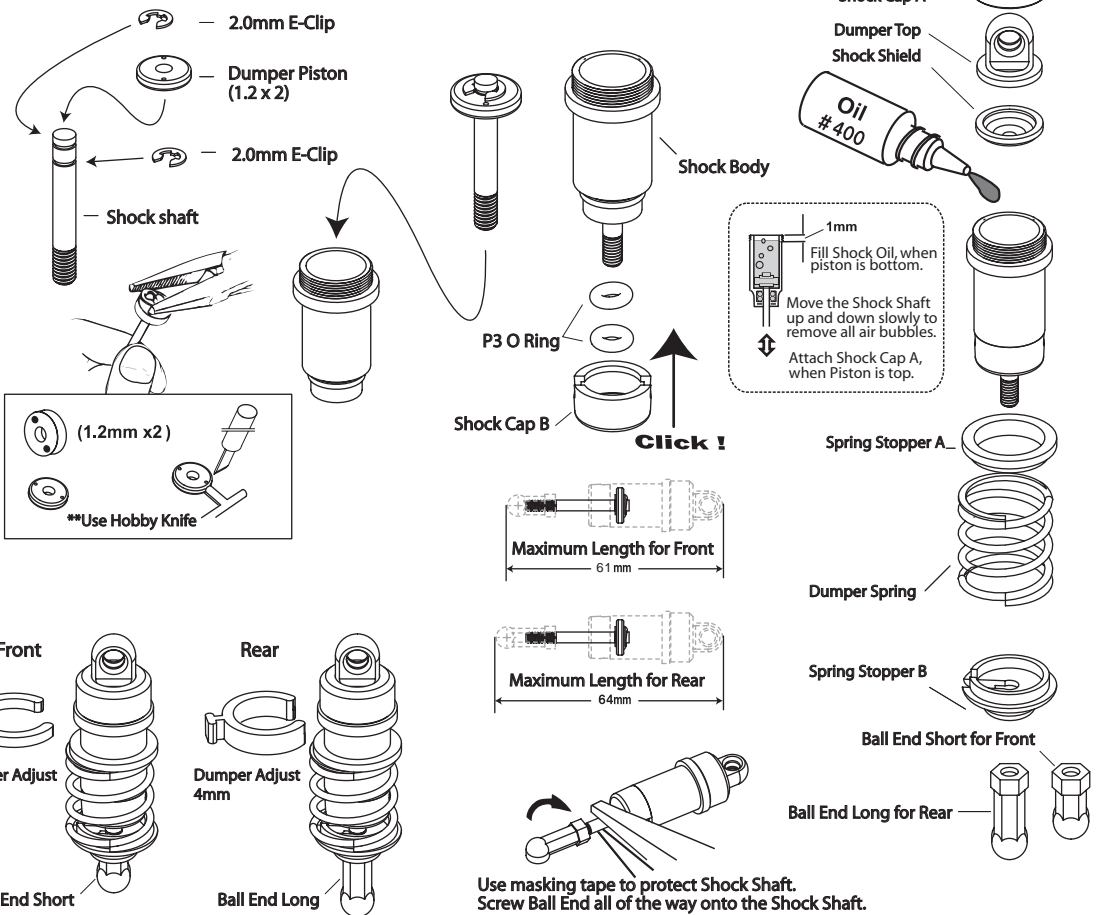
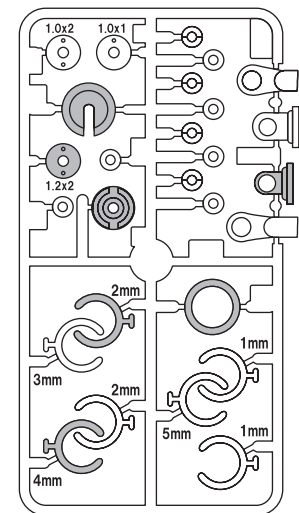

# 13 SHOCK ABSORBER

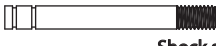

-  2.0mm E-Clip
-  Shock shaft
-  P3 O Ring
-  Shock Shield



# 14 SHOCK / RC ELECTRONICS

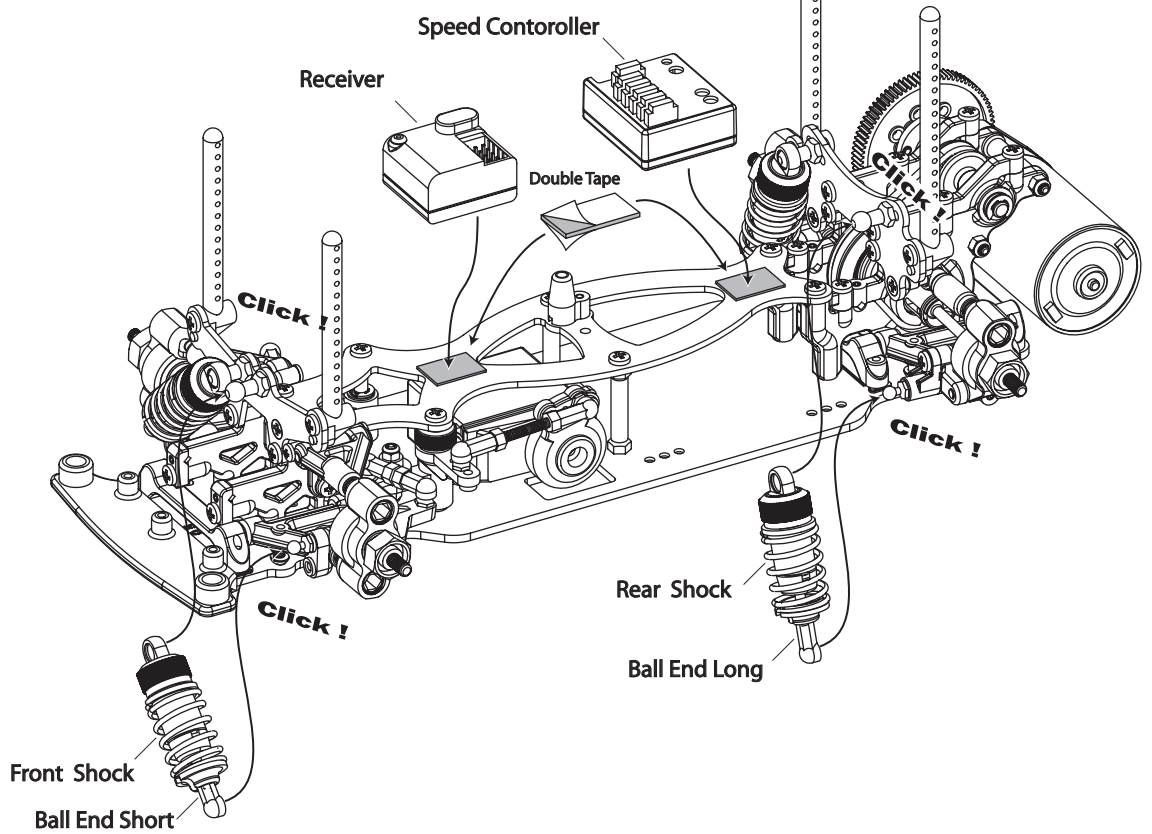

## Gear Ratio (48 Pitch)

	81T	84T	87T
22		7.861	8.142
23		7.519	7.788
24		7.206	7.463
25	6.671	6.918	7.165
26	6.414	6.652	6.889
27	6.176	6.405	6.634
28	5.956	6.176	6.397
29	5.751	5.963	6.176
30	5.559	5.765	5.971
31	5.38	5.579	5.778
32	5.211	5.404	5.597
33	5.053	5.241	5.428
34	4.905	5.087	5.268
35	4.765	4.941	5.118
36	4.632	4.804	4.975
37	4.507	4.674	4.841
38	4.389	4.551	4.714
39	4.276	4.434	4.593
40	4.169	4.324	4.478
41	4.067	4.218	4.369
42		4.118	
43		4.022	

Spur Gear made by XENON



# 15 TIRES & WHEELS

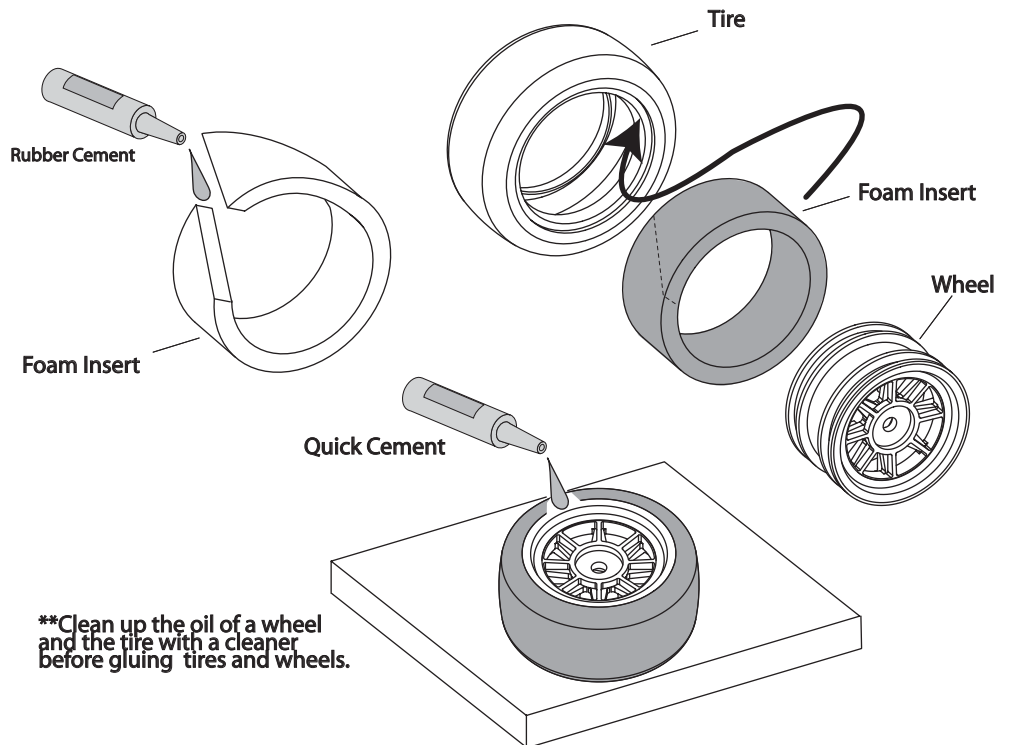



Body Clip

# 16 TIRES/BATTERY



3x10mm Flat Head Screw



Nylon Nut (3mm)



WHEEL NUT 4mm



3mm Washer

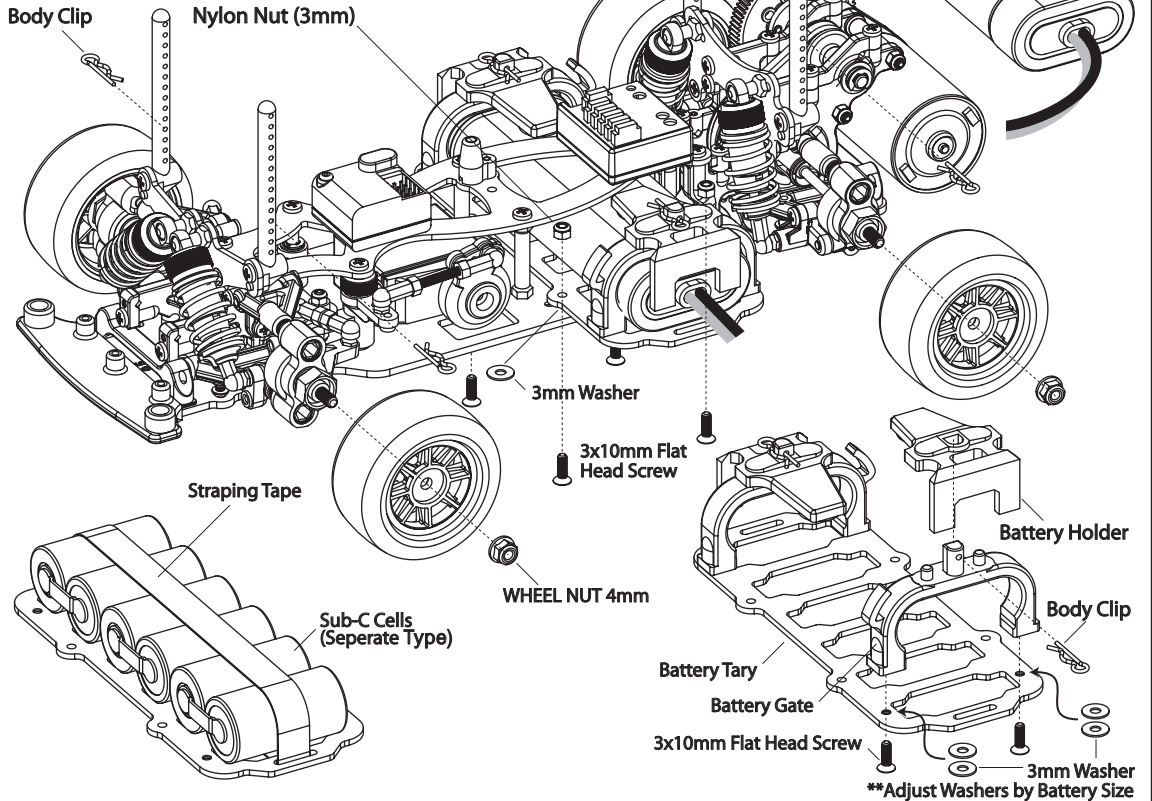

Battery  
7.4V Lipo  
7.2V Ni-cd NI-MH  
6.6V Li-fe

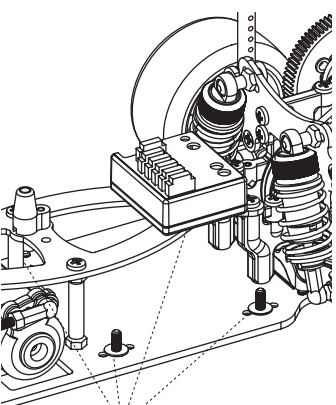

3mm Washer  
\*\*Insert Between Main Chassis and Battery Tray

# 17 ANTENNA / BODY



Body Clip



Antenna Cap

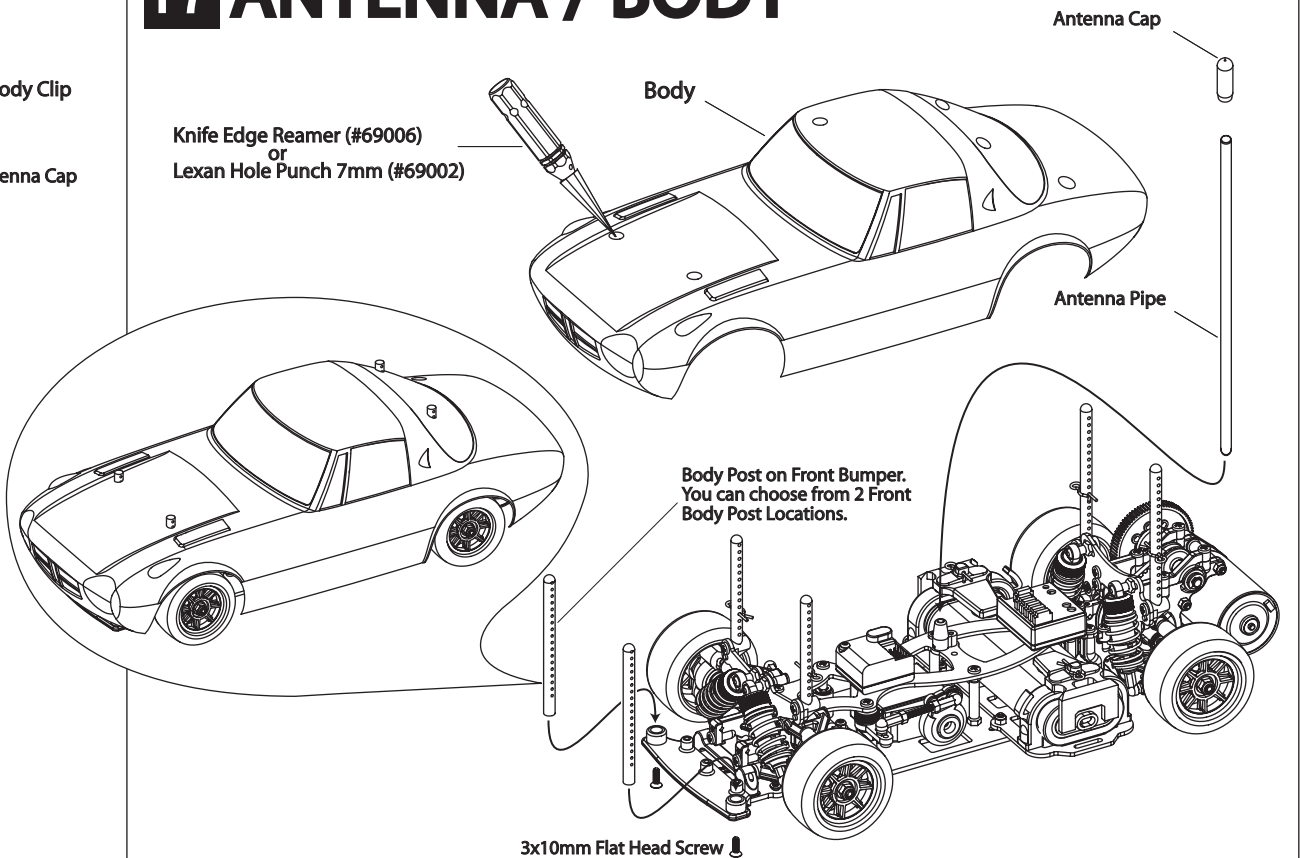

Antenna Cap

Body

Knife Edge Reamer (#69006)  
OR  
Lexan Hole Punch 7mm (#69002)

Antenna Pipe

Body Post on Front Bumper.  
You can choose from 2 Front  
Body Post Locations.

3x10mm Flat Head Screw

# BASIC SETTING

## Front Toe

Toe In  $1^\circ$

### Ackermann

You can choose 2 different Ackermann setting by changing Ball Stud location on Steering Bridge.

4mm Ball Stud

4mm Ball Stud

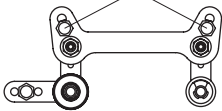

Standard

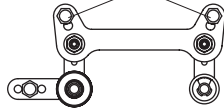

More Steer on out side tire.

## Weight Balance

You can choose 3 different position on Battery Tray. 230g Battery on mid position is Standard weight Balance Setting.

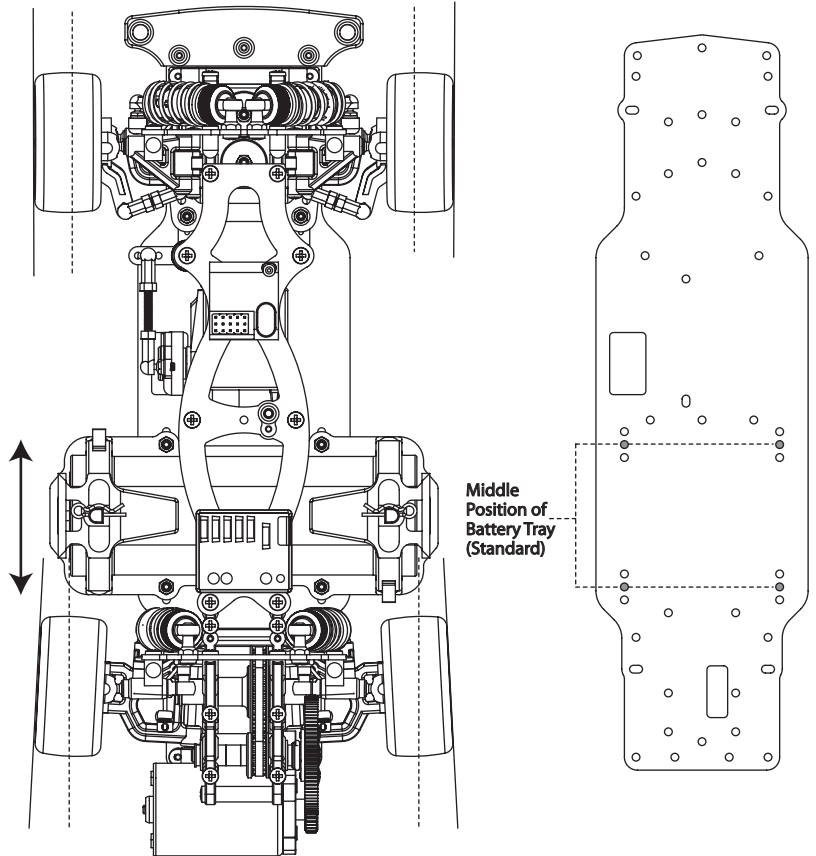

Middle Position of Battery Tray (Standard)

## Rear Toe

Toe In  $3^\circ$

## Ride Height / Droop

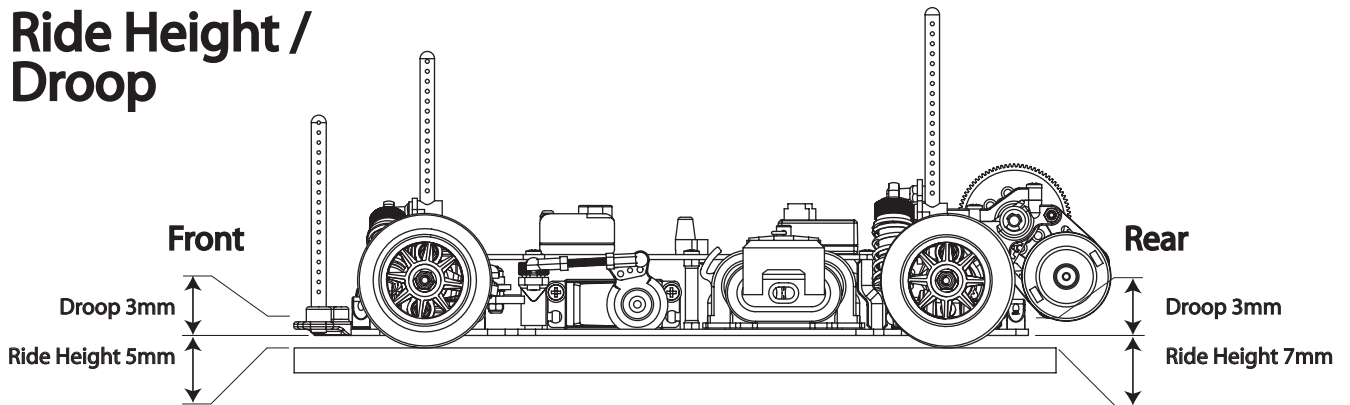

## Camber

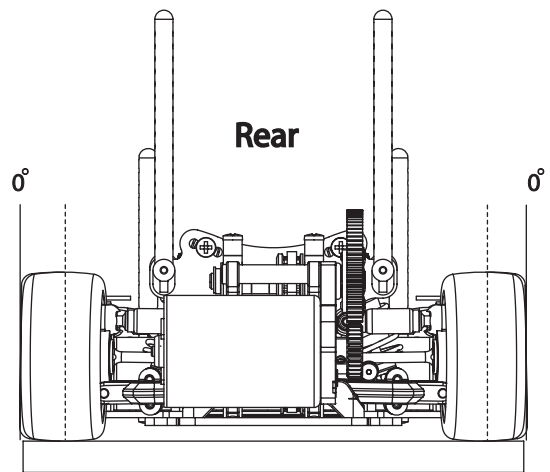
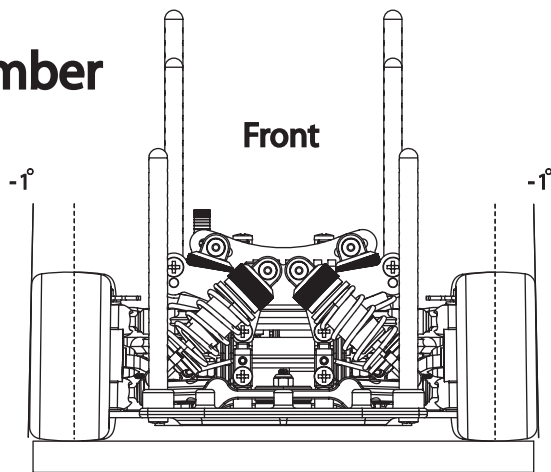

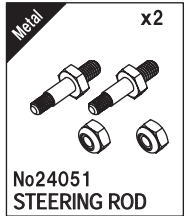
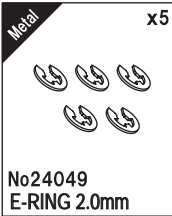
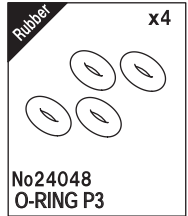
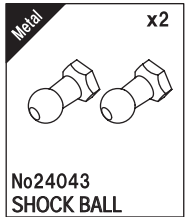
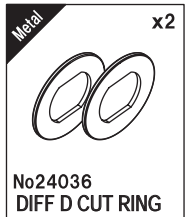
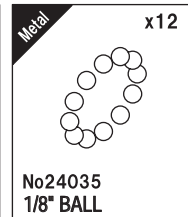
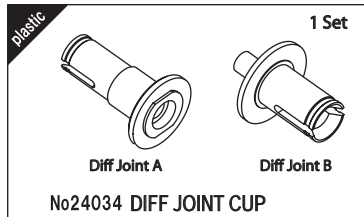
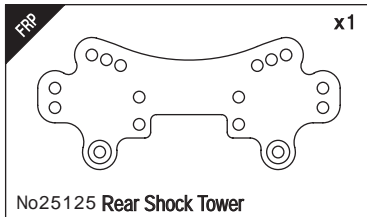
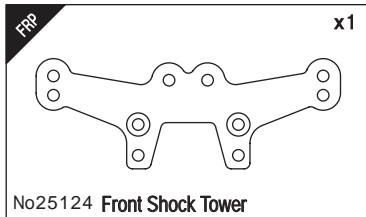
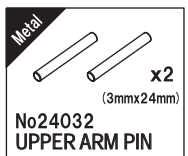
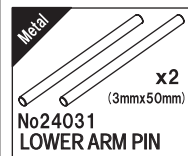
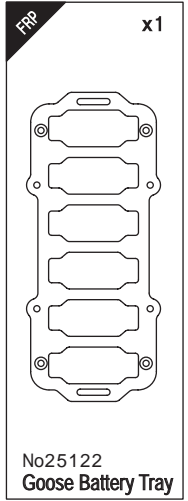
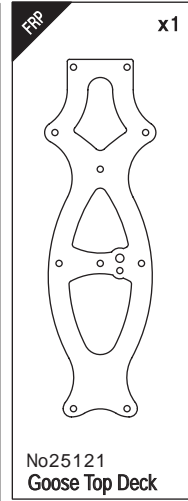
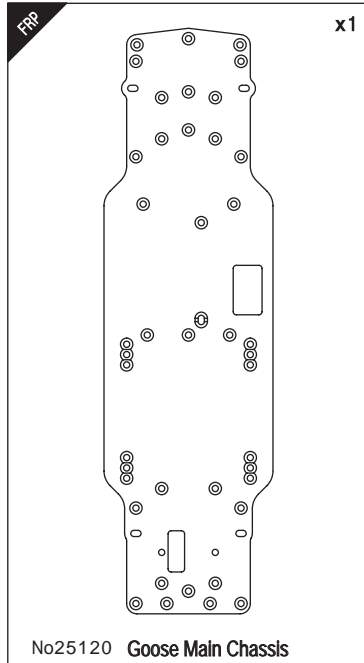
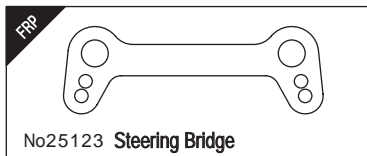
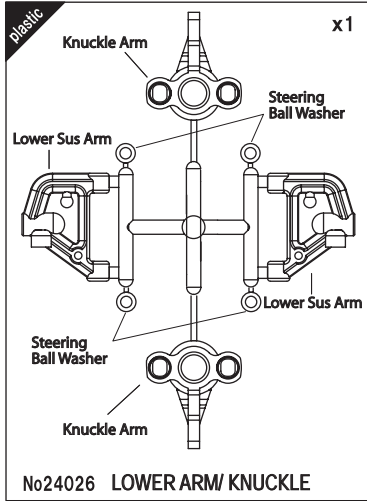
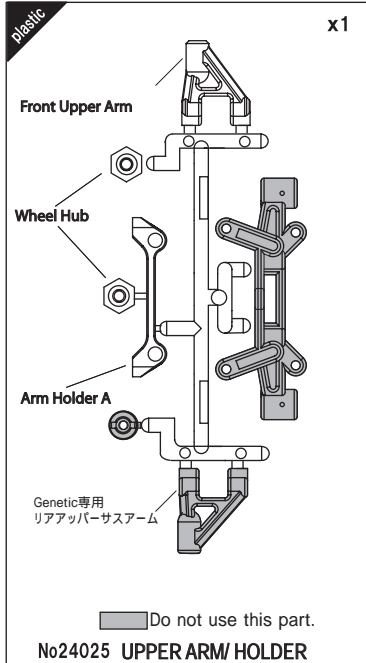
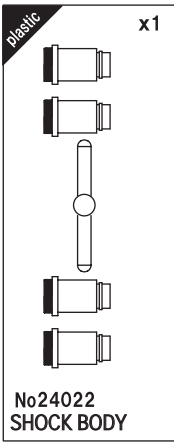
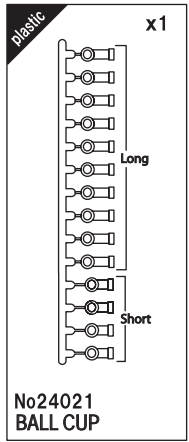
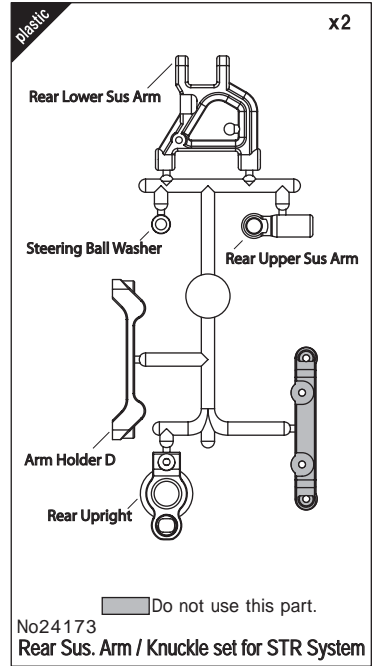
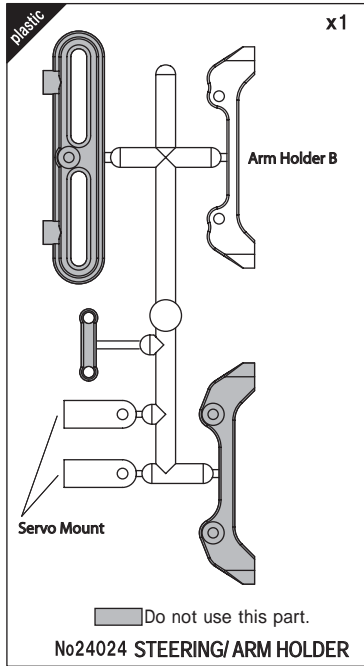
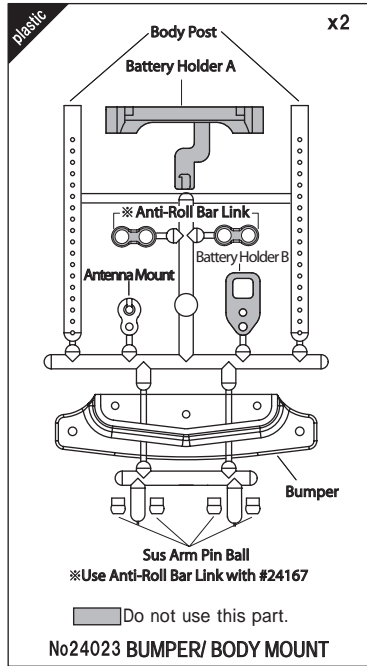
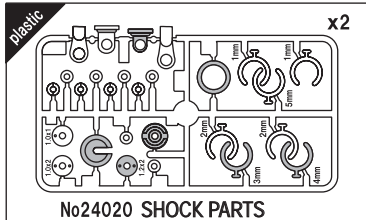



plastic 1 Set



No24052  
MG SERVO SAVER

Metal x1

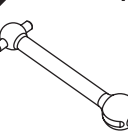

No24054  
DOG BONE

Metal x1



No24055  
AXLE SHAFT

Metal (4mmx6mmx0.7t) x4



No24056  
4X6X0.7T RING

Metal (4mmx7mmx2t) x4



No24057  
STEERING 7mm RING

Metal x4

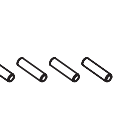

No24059  
2X9.8mm PIN

Metal x4



No24060  
WHEEL NUT 4mm

Metal x2

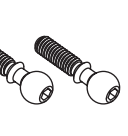

No24064  
STEERING BIG BALL

Metal x2



No24065  
STEERING 7mm NUT

Metal x1



No24066  
GEAR HOLDER

Rubber x2



No24067  
O-RING P8

Metal x4

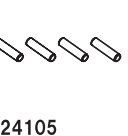

No24105  
2X7.8mm PIN

Metal x10



No24108  
BODY CLIP

plastic x2



No24190  
TTR Wheel,  
HS-White

With Insert Foam x2



No24104  
TTR N RACING TIRE

Bearing x1



No72012  
Ball Bearing 1150

Bearing x1



No72011  
MF105 Bearing

Metal x2

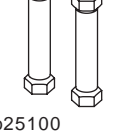

No25100  
Deck Pillar

Metal x1



No25101  
Motor Holder

Metal x2

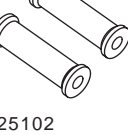

No25102  
Bulkhead Spacer

Metal x2



No25103  
Ball Stud  
5.8mm x 11mm

Metal x1

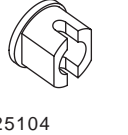

No25104  
Pulley Mount

Metal x1



No25105  
Steering Wiper Nut

Metal x1



No25106  
Steering Pipe

Metal x1



No25107  
Goose  
Front Axle Shaft

Metal x1



No25108  
Center Gear Shaft

Metal x1



No25109  
Steering Post

Metal x5



No25110  
E-Ring 3.0mm

Metal x5



No25111  
E-Ring 4.0mm

Metal 1 Set

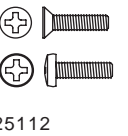

No25112  
Goose Screw Set

Rubber x1



No25113  
Drive Belt

plastic



No24070 ANTENNA TUBE

plastic x1



No24070 ANTENNA TUBE

plastic



No25113  
Pinion Gear 32T

plastic



No25113  
Spur Gear 84T

Metal



No25113  
Pinion Gear 32T

plastic



No25113  
Spur Gear 84T

plastic x2

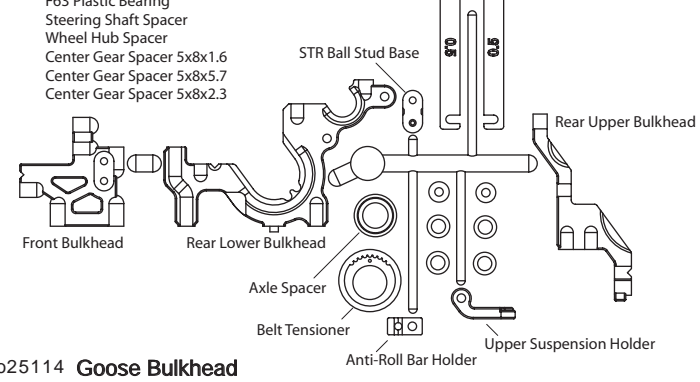

F63 Plastic Bearing  
Steering Shaft Spacer  
Wheel Hub Spacer  
Center Gear Spacer 5x8x1.6  
Center Gear Spacer 5x8x5.7  
Center Gear Spacer 5x8x2.3

STR Ball Stud Base  
Skid Plate  
Rear Upper Bulkhead  
Front Bulkhead  
Rear Lower Bulkhead  
Axle Spacer  
Belt Tensioner  
Anti-Roll Bar Holder  
Upper Suspension Holder

No25114 **Goose Bulkhead**

plastic x1

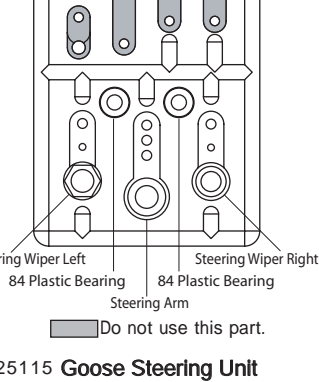

Steering Wiper Left  
84 Plastic Bearing  
Steering Arm  
84 Plastic Bearing  
Steering Wiper Right

Do not use this part.

No25115 **Goose Steering Unit**

plastic x1

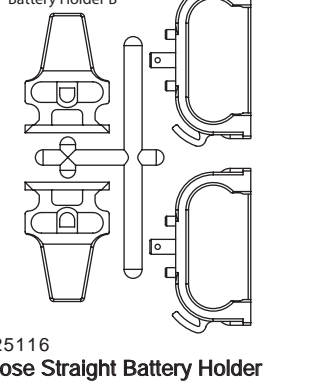

Battery Holder A  
Battery Holder B

No25116 **Goose Straight Battery Holder**

plastic x1

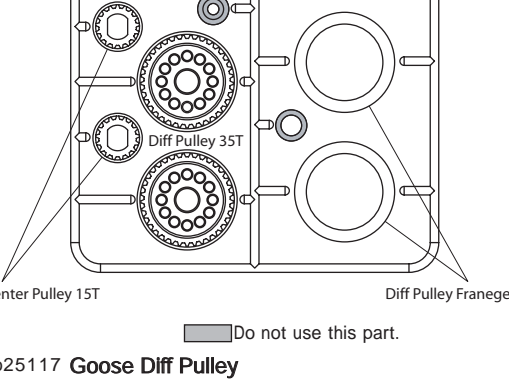

Center Pulley 15T  
Diff Pulley 35T  
Diff Pulley Franage

Do not use this part.

No25117 **Goose Diff Pulley**

plastic x1

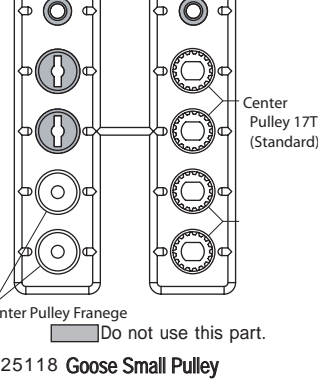

Center Pulley 17T (Standard)  
Center Pulley Franage

Do not use this part.

No25118 **Goose Small Pulley**



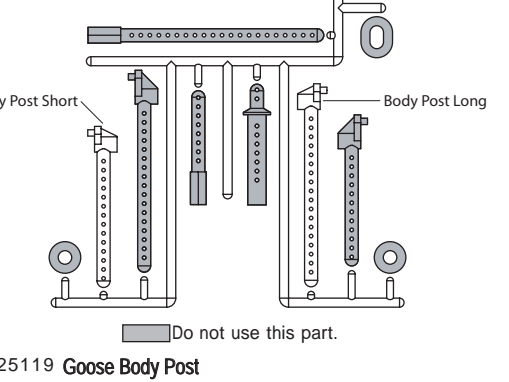

plastic x1

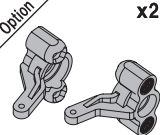
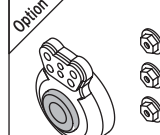
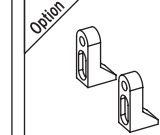
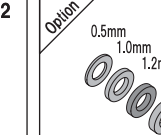
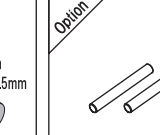
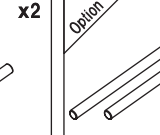
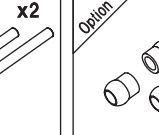
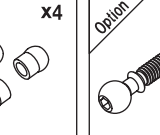
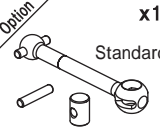
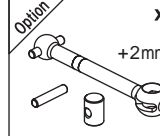
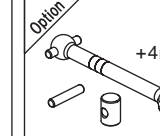
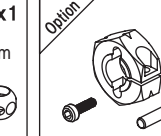
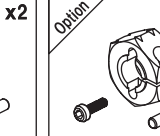
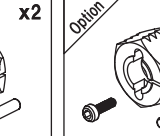
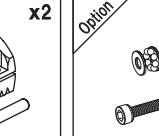
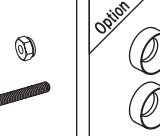
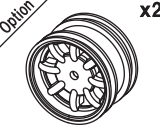
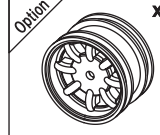
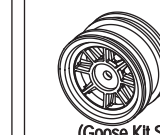
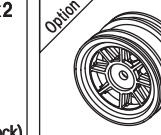
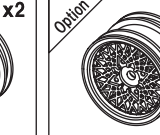
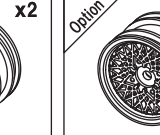
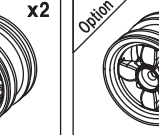
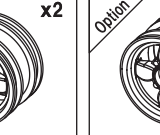
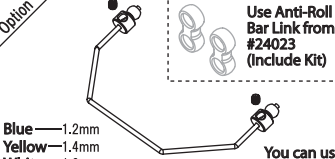
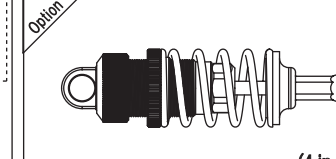
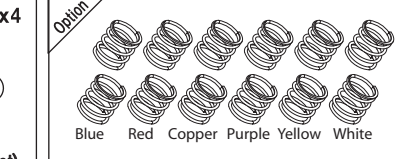

Body Post Short  
Body Post Long

Do not use this part.

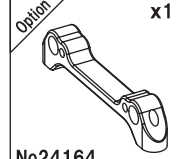
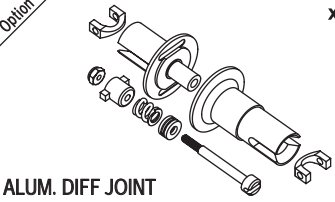
No25119 **Goose Body Post**

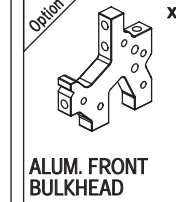
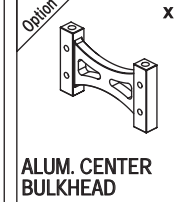
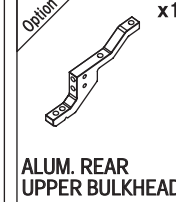
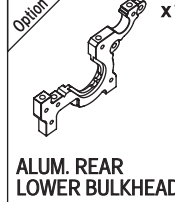
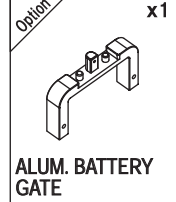
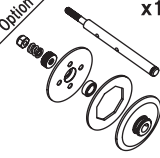
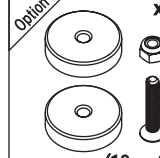
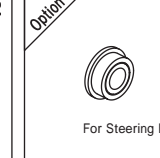
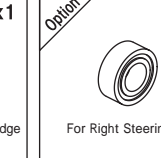
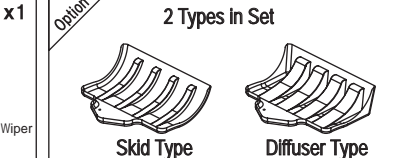
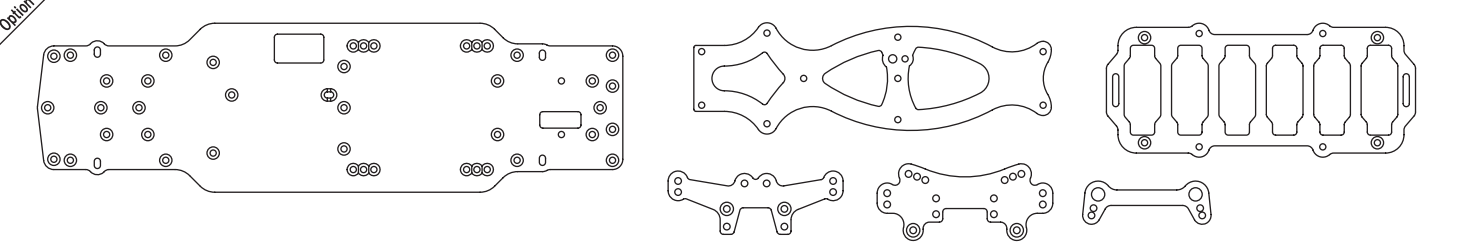
 <p><b>No24166</b> KNUCKLE / REINFORCED</p>	 <p><b>No24124</b> HEAVY DUTY SERVO SAVER</p>	 <p><b>No24161</b> ALUM. SERVO MOUNT</p>	 <p><b>No24170</b> ADJUSTABLE SPACER SET</p>	 <p><b>No24151</b> Heavy Duty Sus. Arm Pin S</p>	 <p><b>No24152</b> Heavy Duty Sus. Arm Pin L</p>	 <p><b>No24169</b> Metal Sus. Arm Pin Ball</p>	 <p><b>No24145</b> STEERING BIG BALL/ LONG</p>
 <p><b>No24146</b> REINFORCED ALUM. DOG BONE S (32.5mm)</p>	 <p><b>No24147</b> REINFORCED ALUM. DOG BONE M (34.5mm)</p>	 <p><b>No24148</b> REINFORCED ALUM. DOG BONE L (36.5mm)</p>	 <p><b>No24155</b> ALUM. HUB 5mm</p>	 <p><b>No24156</b> ALUM. HUB 6mm</p>	 <p><b>No24157</b> ALUM. HUB 7mm</p>	 <p><b>No24143</b> UPGRADE DIFF SCREW/NUT</p>	 <p><b>No24168</b> Teflon Steering Ball Washer</p>
 <p><b>No24118</b> RIMS/ BLACK, REINFORCED</p>	 <p><b>No24128</b> RIMS/ WHITE, REINFORCED</p>	 <p><b>No24190</b> TTR Wheel, HS, White</p>	 <p><b>No24191</b> TTR Wheel, HS, Black</p>	 <p><b>No24193</b> TTR Wheel, S-Mesh, White</p>	 <p><b>No24194</b> TTR Wheel, S-Mesh, Black</p>	 <p><b>No24195</b> TTR Wheel, BRE, White</p>	 <p><b>No24196</b> TTR Wheel, BRE, Black</p>
 <p><b>No24167</b> ANTI ROLL BAR SET</p> <p>Blue—1.2mm Yellow—1.4mm White—1.6mm</p> <p>You can use front or rear.</p>	 <p><b>No24100</b> Accuracy Aluminum Dumper</p> <p>(4 in Set)</p>	 <p><b>No24171</b> SHOCK SPRING SET</p> <p>Blue Red Copper Purple Yellow White</p> <p>6 Pair Springs in Set</p>	 <p><b>No24163</b> ALUM. ARM HOLDER A</p>	 <p><b>No24164</b> ALUM. ARM HOLDER B</p>			
 <p>ALUM. DIFF JOINT</p>	 <p>ALUM. UPPER SUS-HOLDER</p>	 <p>ALUM. FRONT BULKHEAD</p>	 <p>ALUM. CENTER BULKHEAD</p>	 <p>ALUM. REAR UPPER BULKHEAD</p>	 <p>ALUM. REAR LOWER BULKHEAD</p>	 <p>ALUM. BATTERY GATE</p>	
 <p>SLIPPER CLUTCH</p>	 <p><b>No25151</b> (10g x 2) Extra Weight</p>	 <p><b>No72003</b> Ball Bearing 3x6F</p> <p>For Steering Bridge</p>	 <p><b>No72004</b> Ball Bearing 4x8</p> <p>For Right Steering Wiper</p>	 <p><b>No25150</b> GOOSE MOTOR GUARD</p> <p>2 Types in Set</p> <p>Skid Type Diffuser Type</p>			
 <p>CARBON CHASSIS SET</p>							

**Goose**  
New Generation 2 Wheel Drive

Radio Control Parts  
**ABC HOBBY**  
**USA**

www.abchobbyusa.com  
info@abchobbyusa.com