

RC10TC6.2 **FACTORY** Team

#30109 RC10TC6.2 Factory Team Kit



1:10 Scale Electric 4WD Touring Car Kit Manual & Catalog

TEAM ASSOCIATED



Designed in California, USA

:: Introduction

Thank you for purchasing this Team Associated product. This assembly manual contains instructions and tips for building and maintaining your new RC10TC6.2. Please take a moment to read through this manual to help familiarize yourself with these steps.

We are continually changing and improving our designs; therefore, actual parts may appear slightly different than in the illustrations. New parts will be noted on supplementary sheets located in the appropriate parts bags. Check each bag for these sheets before you start to build.

:: KIT Features

Team Associated is proud to release the next step in its developmental line of 1:10th scale 4WD electric touring car kits, the RC10TC6.2-FT, further refining the already successful TC6 platform.

The touring car racing class has been moving forward at an aggressive rate, and the Engineers behind the doors of Area-51 have been hard at work evolving the TC6 platform to keep the pace. The RC10TC6.2-FT car kit comes equipped with a host of new features to allow for more precise suspension adjustment and consistent handling for any track condition.

With over two year's development on the TC6 chassis, the TC6.2-FT car kit ties together all the experience and Factory Team race tested parts. Focusing on precise suspension adjustments with features such as the new independent arm mount system with interchangeable toe inserts and pivot ball joints. A new dual bellcrank steering system has optimal Ackermann and steering rates, and is controlled by a servo on a floating mount for steering to match today's aggressive racing conditions. Updated bulkhead and top plate configurations allow for optimized flex through the entire length of chassis to give the best grip on any surface. The RC10TC6.2-FT packs together the key features necessary to keep you at the top of the racing circuit. All without sacrificing low part count or affordability. It's plain to see that the RC10TC6.2-FT kit is... another "Champion by Design" from Team Associated!

:: Key Features

- Updated arm mount system
 - Pivot ball on inner hinge pin allows free pin movement at any toe or kickup angle
 - Insert system for precise adjustment of inner pin width and toe
 - Independent arm mount design to allow maximum flex through entire chassis length, resulting in better grip on all track conditions
- Dual bellcrank steering system
 - Optimized Ackermann and steering rates
 - Horizontal ballstuds for fine Ackermann adjustments
 - 8 precision bearings for accurate swing motion
- Floating servo mount
 - Servo mounts to chassis center to allow equal chassis flex in both directions and a tweak free assembly
 - Mount ties to steering bellcrank posts for stable servo positioning
 - Slotted servo mount design allows fit for almost any standard servo
- Narrow chassis with optimized flex characteristics
 - 2.25mm graphite laminate for optimized flex characteristics
 - A narrow 88mm wide to minimize chassis dragging at maximum chassis roll angles
 - Chassis ballast mass mounting locations to fine tune mass balance
- Updated spur gear bulkheads
 - Mounting pattern has been made independent of arm mount to allow flex through entire length of chassis improving overall grip
 - Narrowed mounting pattern to allow for more chassis flex and consistent traction
 - Symmetric design helps to minimize part count
- Updated motor mount & spur gear mount
 - Floating spur gear design allows for more flex from rear of chassis helping to gain traction in all conditions
 - Motor mount attaches to center line of chassis with a floating post connection to allow free chassis flex in both directions
- Updated vertical ball stud bearing caps
 - Optimized position for inner ball stud
 - Vertical ballstud orientation allows for fine adjustments of roll center height
 - 3 link position options give precise control of camber gain
- Spur gear lowered by 1.50mm to give more aggressive handling characteristics
- Top plate lowered by 1.50mm to allow for more chassis flex and increased traction in any condition
- Rear gear diff for maximum performance and minimal maintenance
 - Lightweight design
 - Durable composite construction
 - Optimized for a wide "tuning window" to maximize useable adjustability
 - Hard anodized aluminum outdrives for low wear and long life
- Front spool with replaceable composite outdrives
 - Outdrives allow the use of existing CVA bone blades to minimize binding at the bearing surface
 - Composite outdrives are replaceable at low cost in the event of a CVA bone blade failure
- Cross-compatibility with all TC6.1 suspension components
- VCS3 Shock with hard anodized threaded shock bodies
 - Bottom loading seal system for ease of build
 - TiN coated shock shaft
 - Piston attaches to shock shaft with screw for tight clamping and no slop
 - Threaded collar with fine pitch thread for ease of accurate ride height adjustment
- Titanium turnbuckles with turnbuckle eyelets for easy access to ball stud for adjustment
- 22 precision ball bearings

:: Items Needed

Your new FT TC6.2 comes unassembled and requires the following items for completion. (refer to catalog section for suggestions):

- 1:10th scale electric motor and electronic speed control
- 3.7V-7.4V LiPo, 6.6V LiFe, or 4.8V-7.2V NiMh/NiCd battery
- Battery charger (suited for, and particular to, one of the batteries mentioned)
- 2 channel surface transmitter, 2 channel receiver, and steering servo
- 1:10th scale 190mm lexan touring car body and Lexan specific paint for body
- Strapping tape for battery
- 1:10th scale rubber (or foam) touring car tires, rims and inserts

:: Other Helpful Items

- Silicone Shock Fluid (Refer to catalog for complete listings)
- Silicone Diff Fluid (Refer to catalog for complete listings)
- Thread Lock (AE Part #1596)
- Body Scissors (AE Part # 1737)
- Reamer / Hole Punch
- FT Hex Wrenches (AE Part # 1541)
- Hobby Knife
- Needle Nose Pliers
- Wire Cutters
- Soldering Iron
- Calipers or a Precision Ruler

Associated Electrics, Inc.
26021 Commercentre Dr.
Lake Forest, CA 92630



Customer Service
Tel: 949.544.7500
Fax: 949.544.7501

:: Table of Contents

1.....Cover	26-28.....Tuning Tips
2.....Introduction	29.....Gear Chart
3.....Table of Contents	30-37.....Catalog
4-5.....Shock Build (Bag A-AA)	38.....Notes
5-8.....Spool and Differential Build (Bag B-BB)	39.....Setup Sheet "Kit Setup"
8-9.....CVA's and Turnbuckles Build (Bag C-CC)	40.....1:1 Hardware "Fold Out"
10-11.....Suspension Arms Build (Bag D-DD)	41.....Setup Sheet "Blank"
12-16.....Bulkheads, Spur Gear, and Steering Rack Build (Bag E-EE)	42.....Back Cover
16-20.....Steering/Caster Blocks and Rear Hubs Build (Bag F)	
21-25.....Bumper, Anti Roll Bar, and Electronics Build (Bag G-GG)	

:: Notes



This symbol indicates a special note or instruction in the manual.



This symbol indicates a Racers Tip.



There is a 1:1 hardware fold out page in the back of the manual. To check the size of a part, line up your hardware with the correct drawing until you find the exact size. Each part in the foldout has a number assigned to it for ordering replacement parts.

**Associated Electrics, Inc.
26021 Commercentre Dr.
Lake Forest, CA 92630**



**Customer Service
Tel: 949.544.7500
Fax: 949.544.7501**

<http://www.TeamAssociated.com> • <http://www.RC10.com> • http://twitter.com/Team_Associated • <http://bit.ly/AEonFacebook>

:: Shock Build - Bag A-AA - Step 1

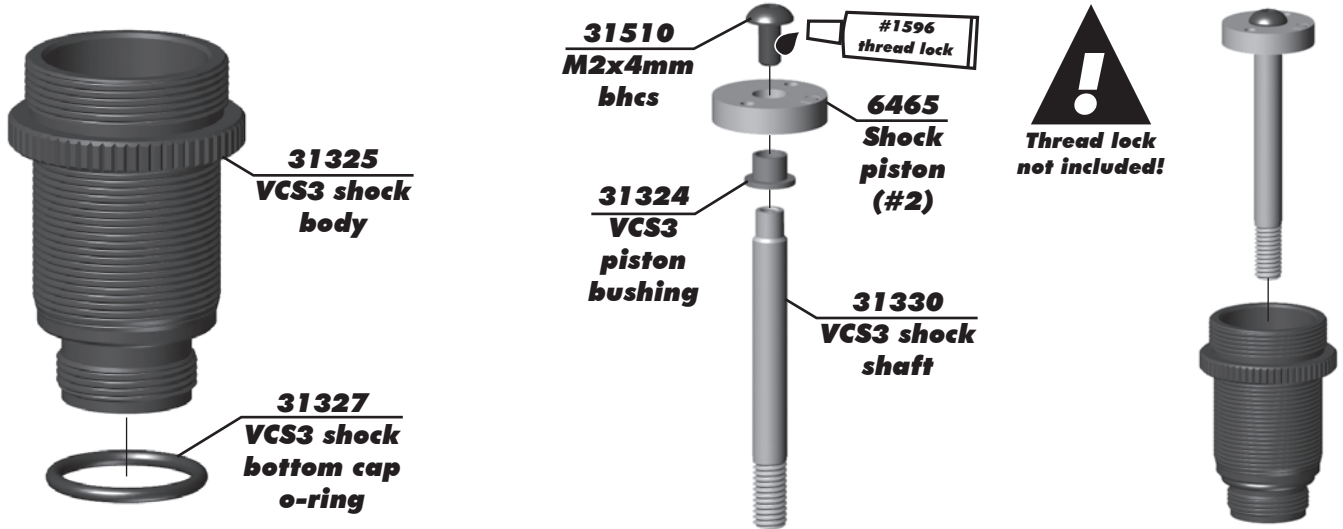

:: Shock Build - Bag A-AA - Step 2

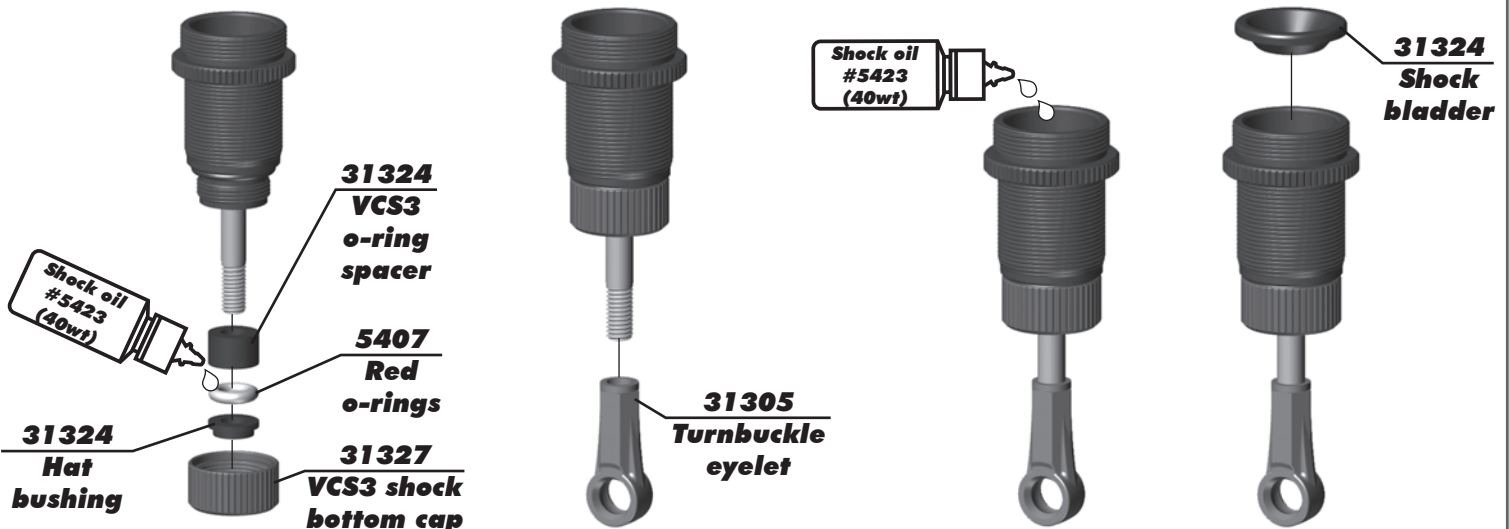

:: Shock Build - Bag A-AA - Step - 3

Bladder Installation

With the shaft extended 25%, place bladder on the top of the shock body, displacing the extra oil. While maintaining pressure on the bladder against the shock body, carefully lift one side of the bladder to allow any extra oil to escape. Place stock cap on top of bladder, and secure it by threading the aluminum cap retainer onto the shock body.

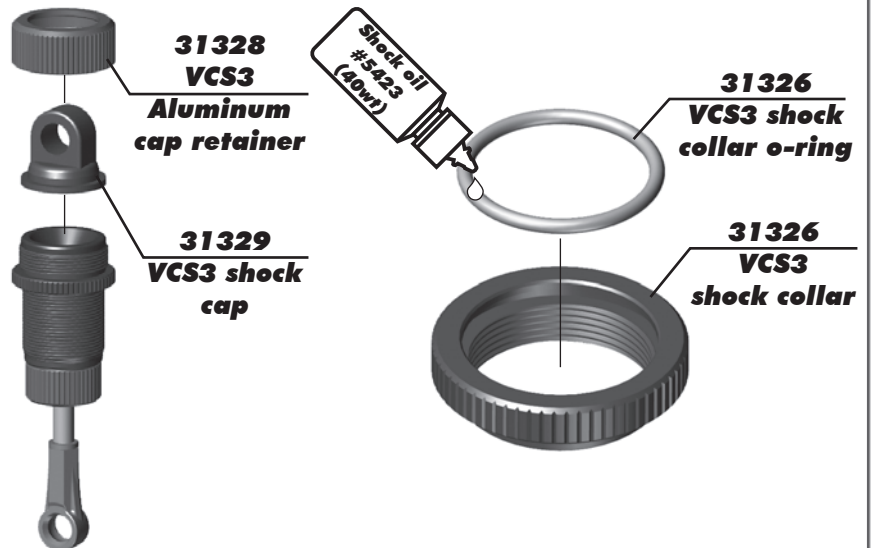

:: Shock Build - Bag A-AA - Step 4

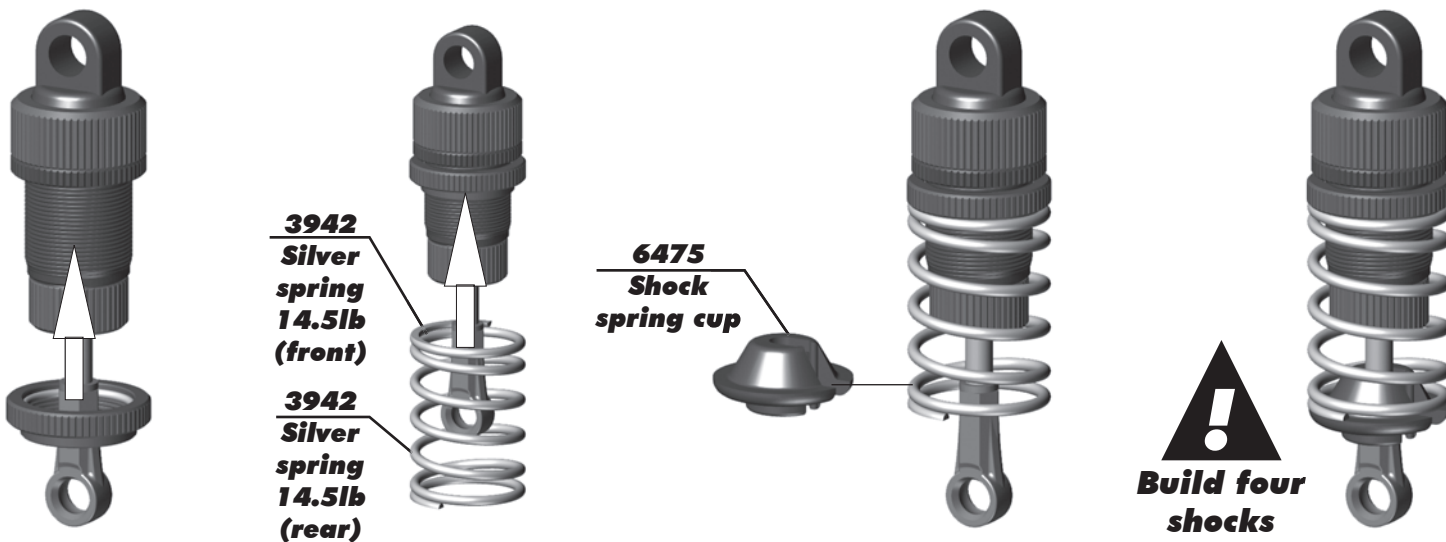

:: Spool and Differential Build - Bag B-BB - Step 1

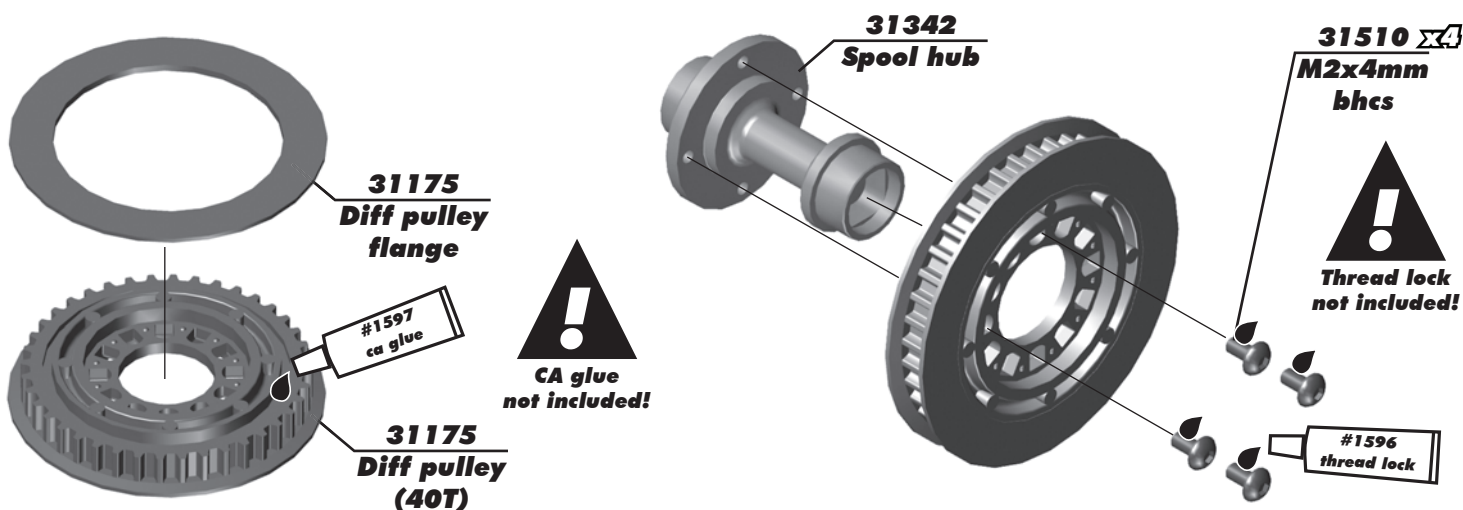

:: Spool and Differential Build - Bag B-BB - Step 2

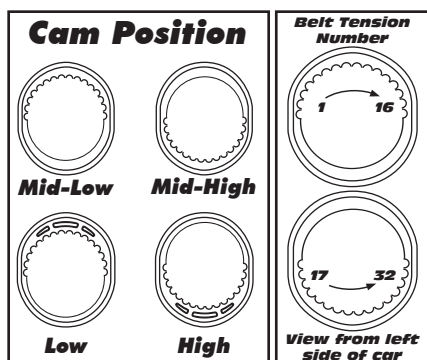

Note!
Always use the same cam position on both sides of the car.

Left Side



Right Side

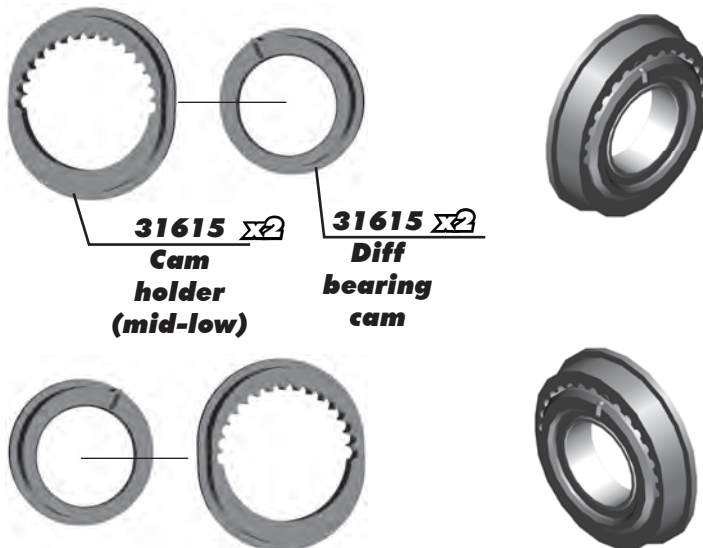

:: Spool and Differential Build - Bag B-BB - Step 3

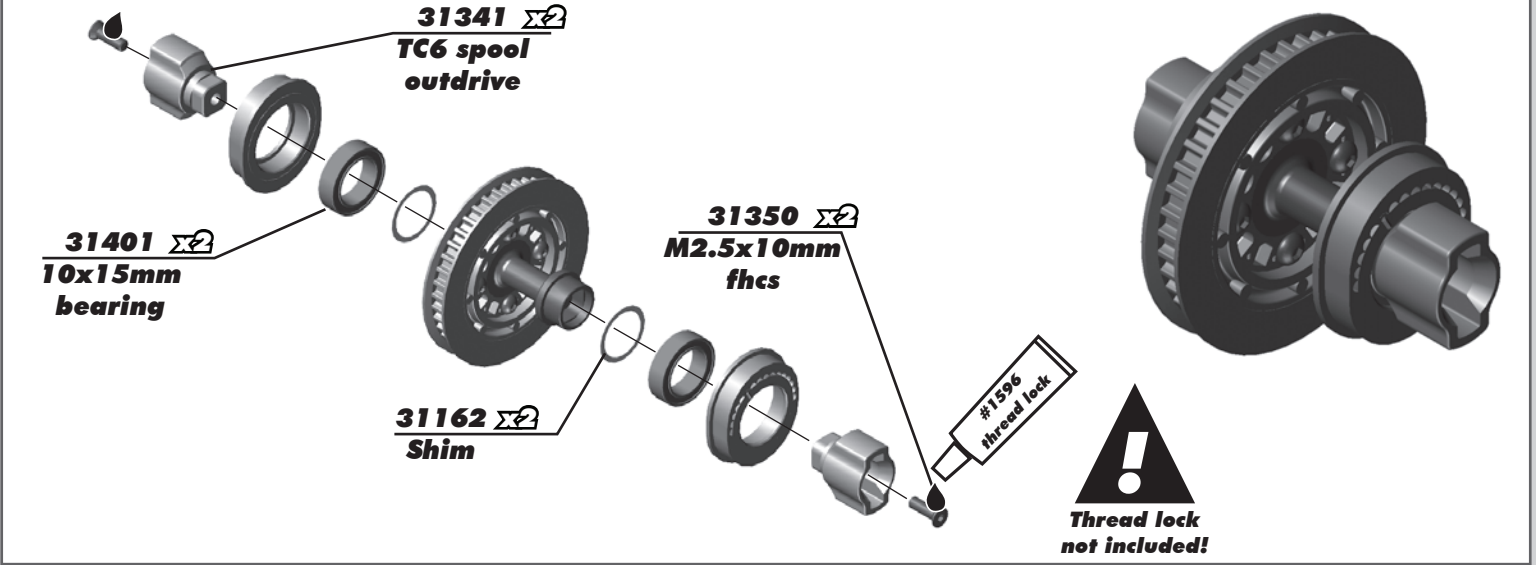

:: Spool and Differential Build - Bag B-BB - Step 4

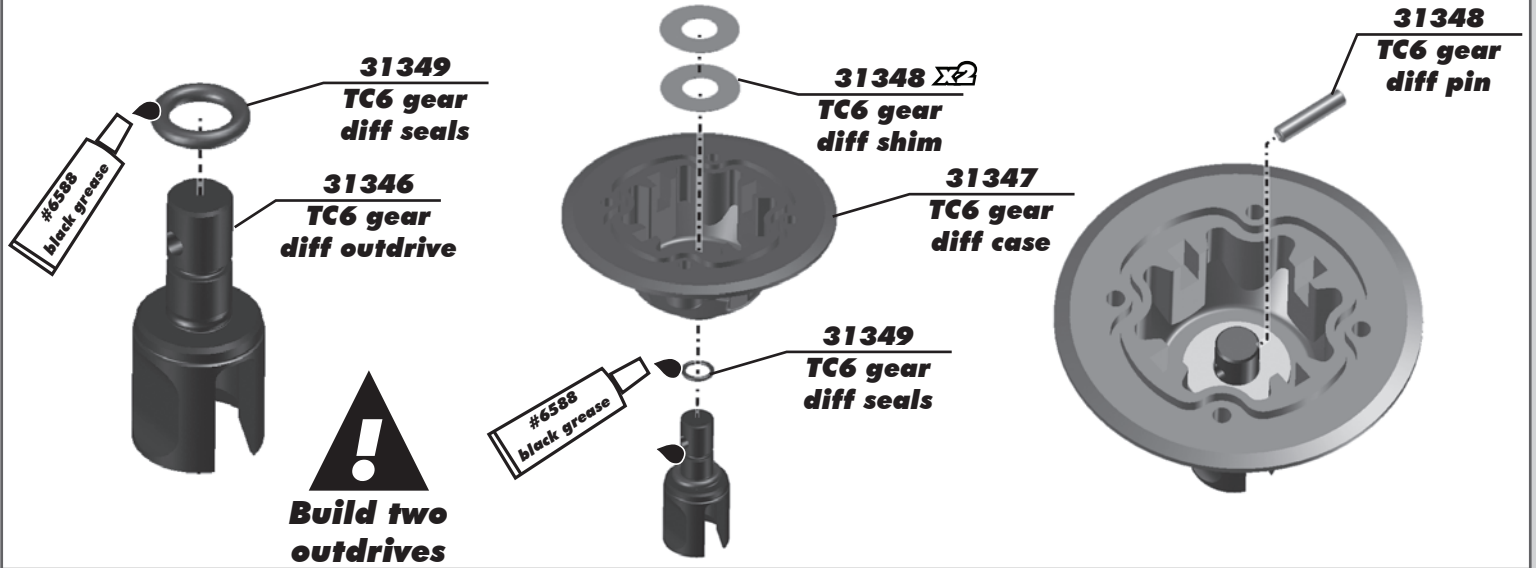

:: Spool and Differential Build - Bag B-BB - Step 5

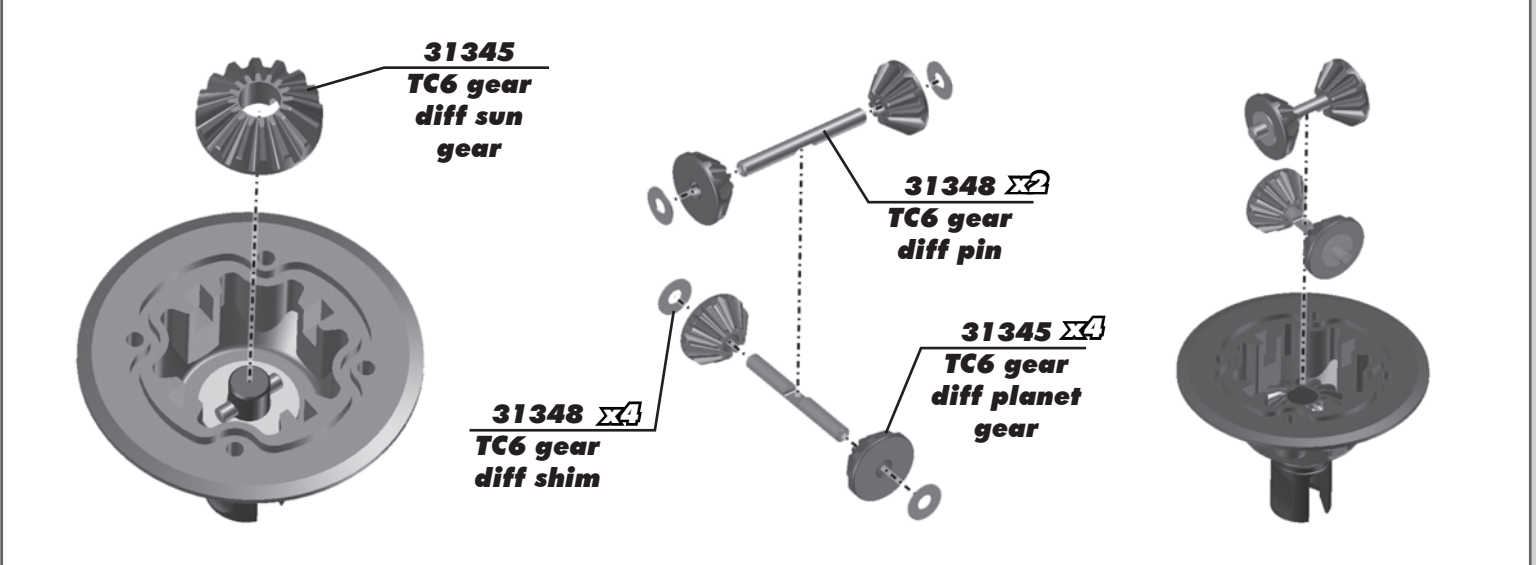

:: Spool and Differential Build - Bag B-BB - Step 6

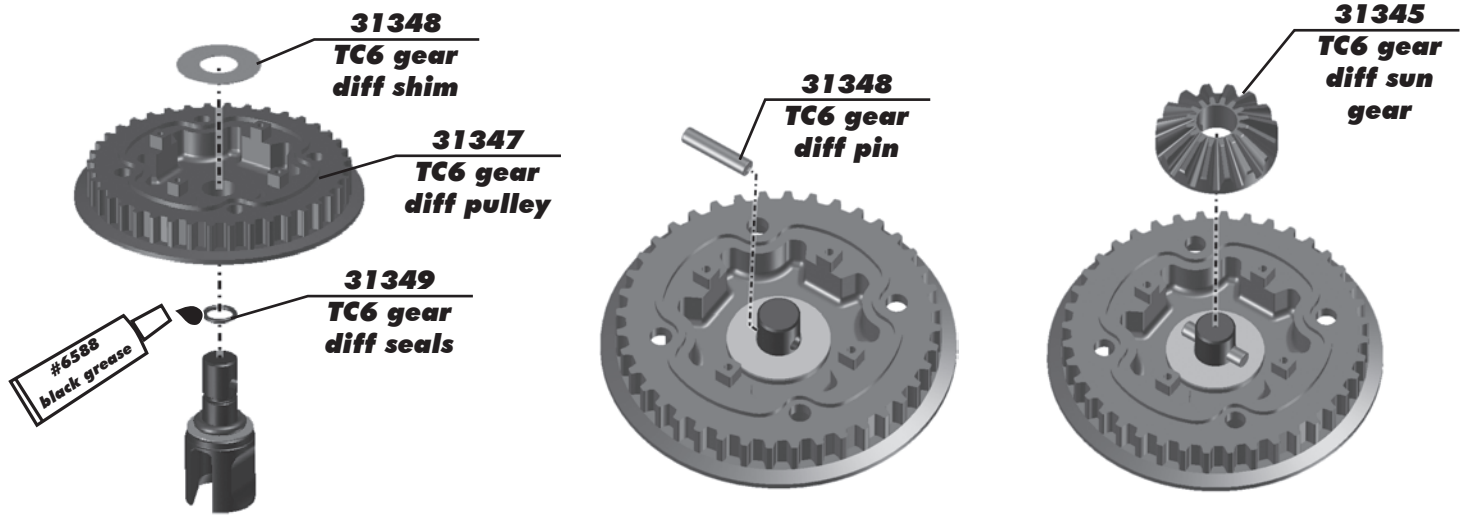

:: Spool and Differential Build - Bag B-BB - Step 7

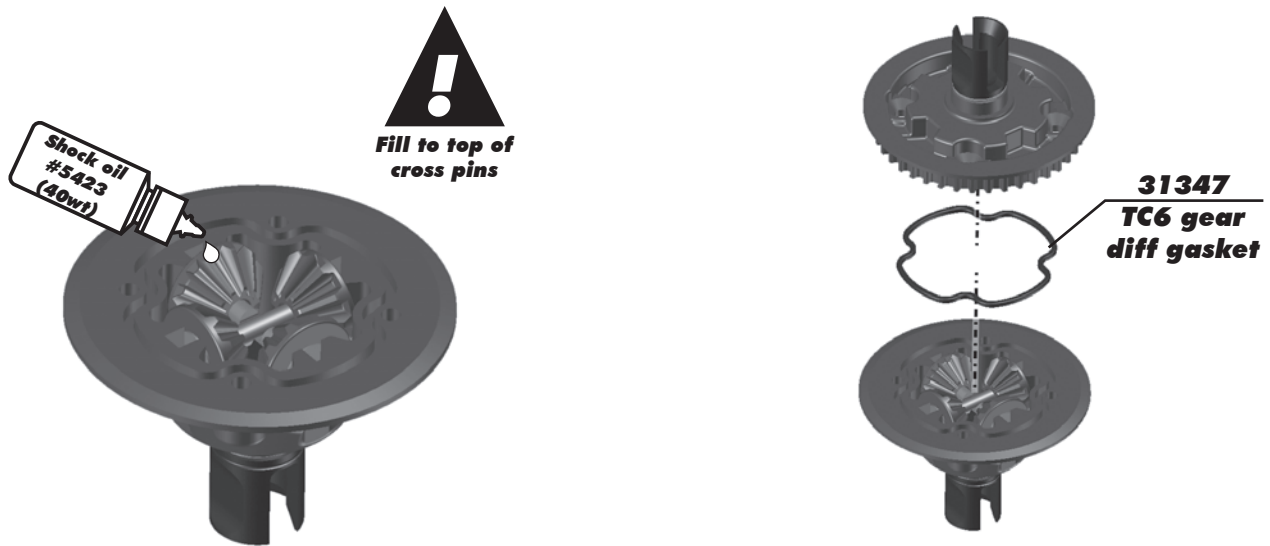

:: Spool and Differential Build - Bag B-BB - Step 8

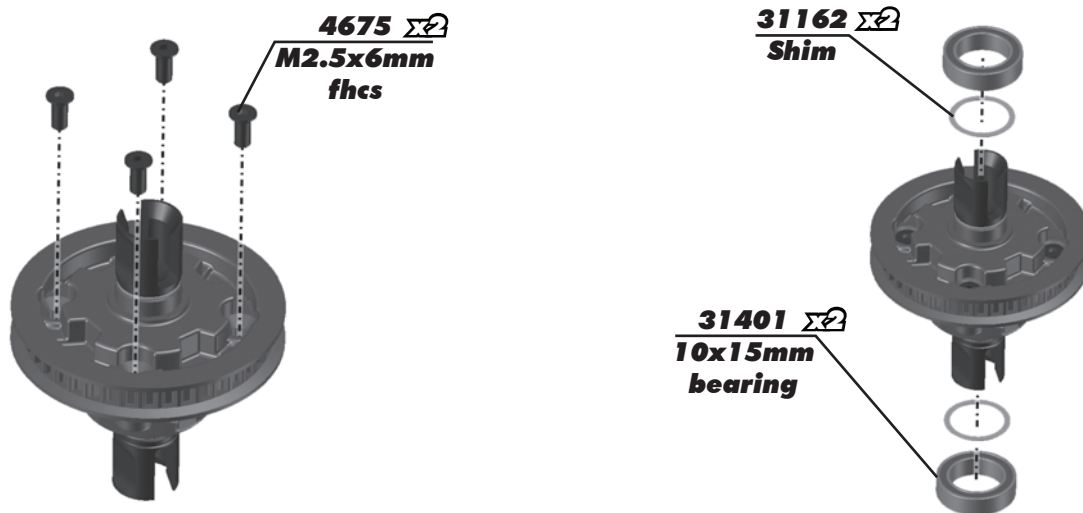

:: Spool and Differential Build - Bag B-BB - Step 9

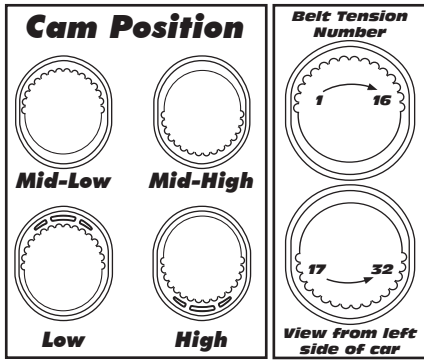

Note!
Always use the same cam position on both sides of the car.

Left Side

Use belt tension position 7 for standard setup.

Right Side

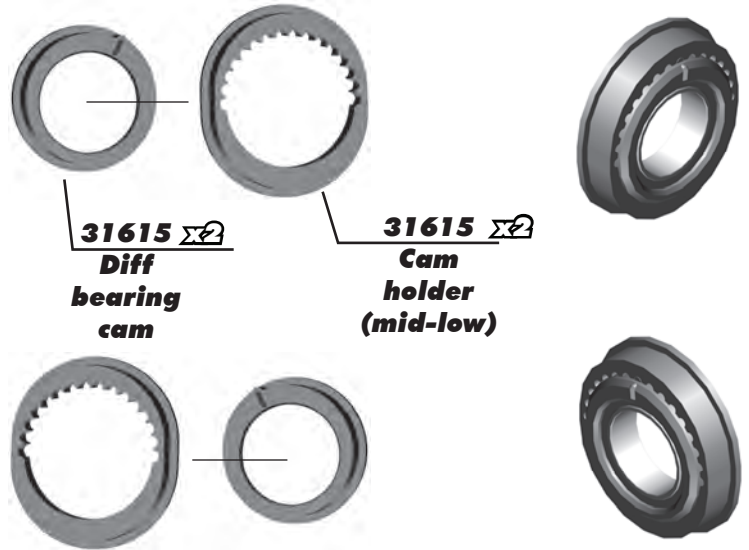

:: Spool and Differential Build - Bag B-BB - Step 10



:: CVA's and Turnbuckles Build - Bag C-CC - Step 1

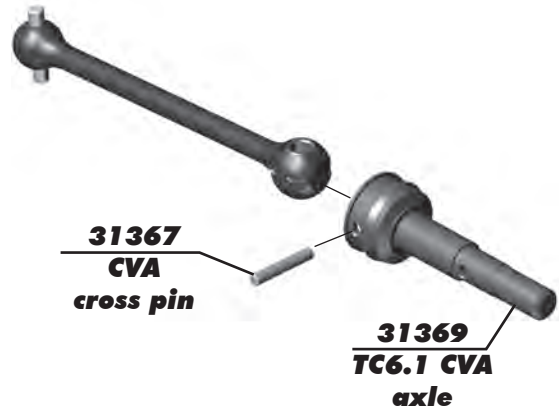
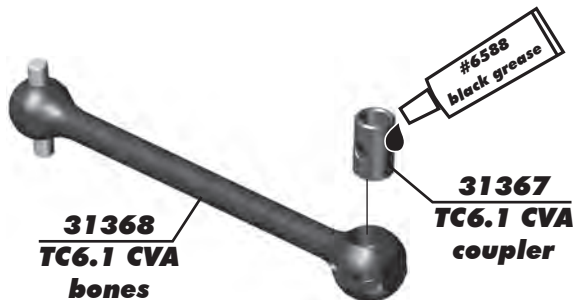

:: CVA's and Turnbuckles Build - Bag C-CC - Step 2

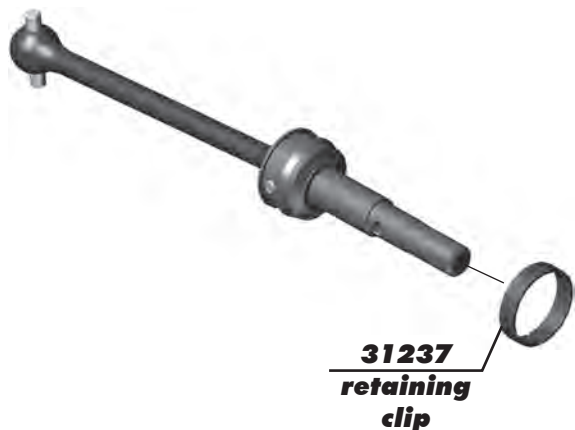

!
Note!
 Align the gap in the pin retainer to be opposite of the CVA pin.



:: CVA's and Turnbuckles Build - Bag C-CC - Step 3

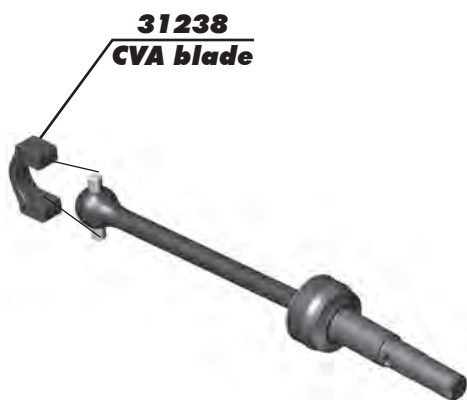

!
Build four CVA's



:: CVA's and Turnbuckles Build - Bag C-CC - Step 4

Servo Turnbuckle

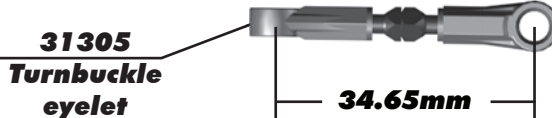

Camber Turnbuckle

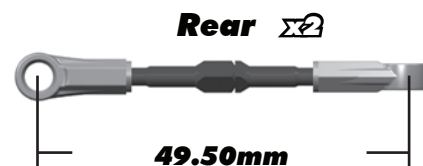
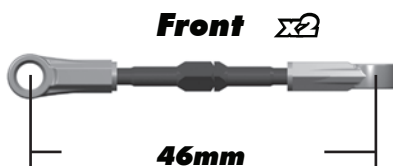

Steering Turnbuckle



:: Suspension Arms Build - Bag D-DD - Step 1

!

Build four inner arm mounts

31619
TC6.2 Inner arm mount

31620
TC6.2 arm mount insert (1 dot)

4617 x4
Front bulkhead shim (0.5mm)

31600
TC6.2 chassis

31541 x4
M3x6mm fhcs

!

Install front and rear

Arm Mount Inserts

-3 DOT	-2 DOT	1 DOT	+2 DOT	+3 DOT
-1°	-1/2°	0°	+1/2°	+1°

Negative to the inside of vehicle.
Positive to the outside of vehicle.

:: Suspension Arms Build - Bag D-DD - Step 2

25227
M4x8mm setscrew

31221
Inner hinge pin

31621 x2
Inner hinge pin ball

31200
Wheelbase shim (1mm)

31280
5mm ballstud (short)

31356
Front suspension arm

31356
Front suspension arm insert (B)

!

Build left and right sides

Wheel Base Shims

1mm	2mm

Suspension Arm Insert (front)

:: Suspension Arms Build - Bag D-DD - Step 3

25227
M4x8mm setscrew

31221
Inner hinge pin

31621 x2
Inner hinge pin ball

31200
Wheelbase shim (1mm)

31283
5mm ballstud (long)

31357
Rear suspension arm

31357
Rear suspension arm insert (B)

!

Build left and right sides

Wheel Base Shims

1mm	2mm

Suspension Arm Insert (rear)

:: Suspension Arms Build - Bag D-DD - Step 4

31620 $\Sigma 2$
**TC6.2 arm
 mount insert
 (1 dot)**



**Build two, one for
 front, one for rear.
 Both with 1 dot inserts**

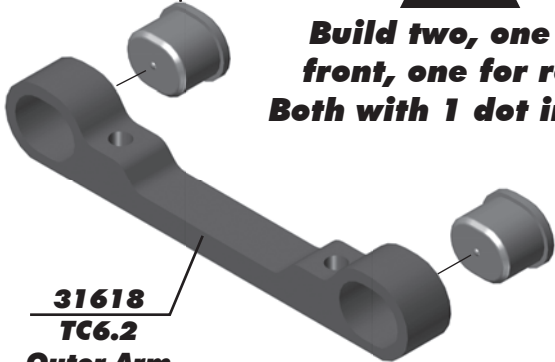

31618
**TC6.2
 Outer Arm
 Mount**

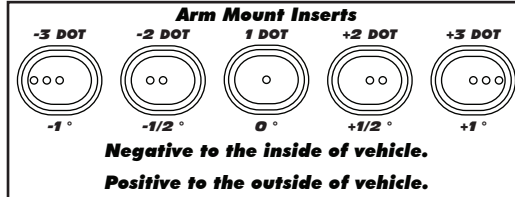
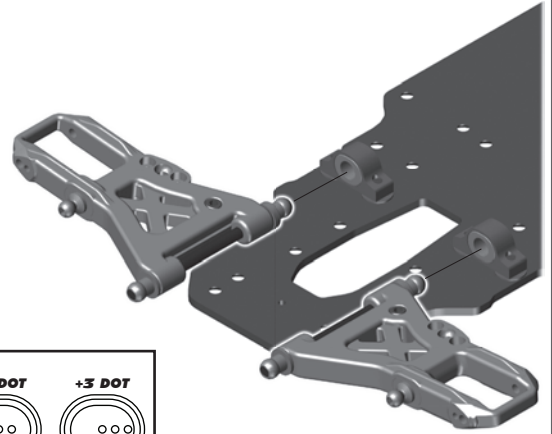

:: Suspension Arms Build - Bag D-DD - Step 5

4617 $\Sigma 2$
**Front
 bulkhead
 shim
 (0.5mm)**

31541 $\Sigma 2$
**M3x6mm
 fhcs**

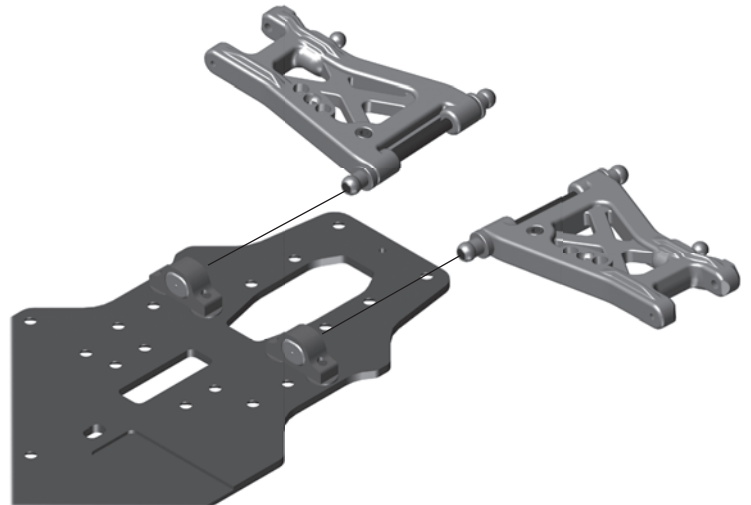
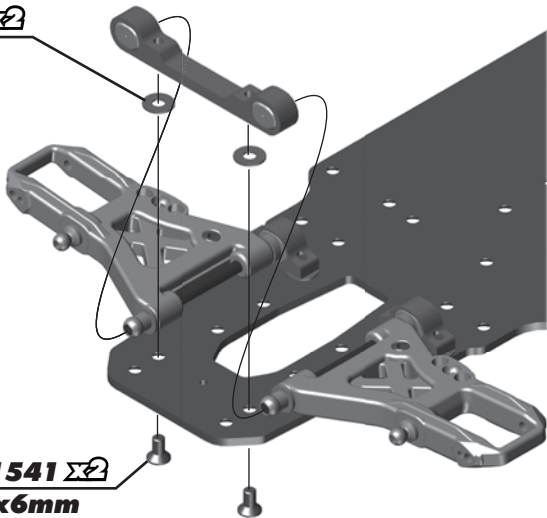

:: Suspension Arms Build - Bag D-DD - Step 6

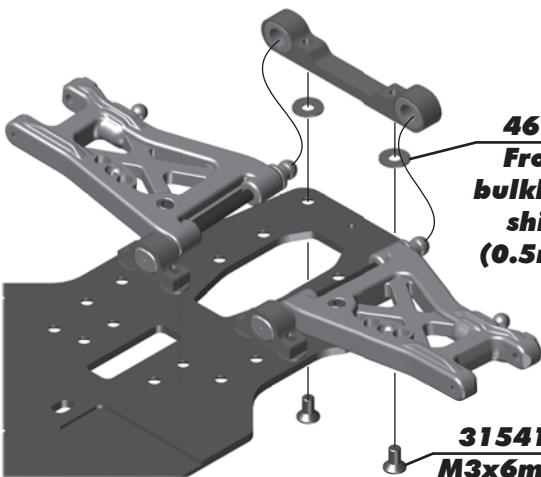

4617 $\Sigma 2$
**Front
 bulkhead
 shim
 (0.5mm)**

31541 $\Sigma 2$
**M3x6mm
 fhcs**

Droop:

The standard settings of 6mm front and 5mm rear will work best in most cases. Droop is measured just underneath the outer hinge pin as shown in the photos to the right.

On bumpy or low grip surfaces, increase the droop (going to a lower number on the droop gauge), this will help increase traction and consistency.

Droop adjustments of 0.5mm to 1mm can be very effective on the track!

**Front Droop
 Setting: 6mm**



**Rear Droop
 Setting: 5mm**



:: Bulkheads, Spur Gear, and Steering Build - Bag E-EE - Step 1

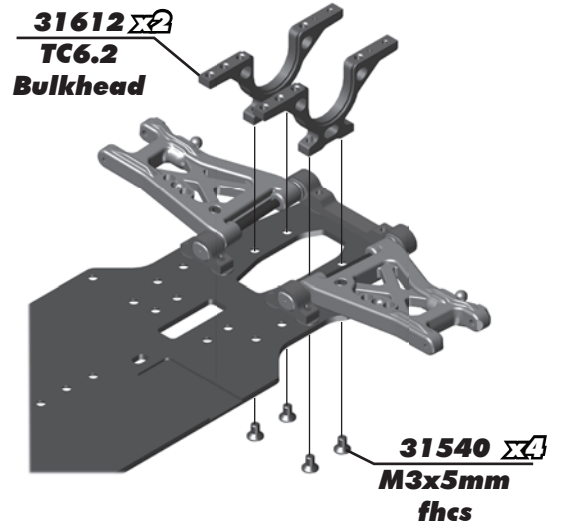
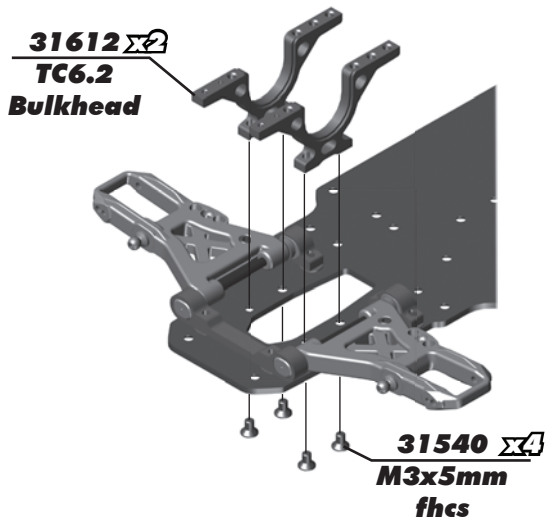

:: Bulkheads, Spur Gear, and Steering Build - Bag E-EE - Step 2

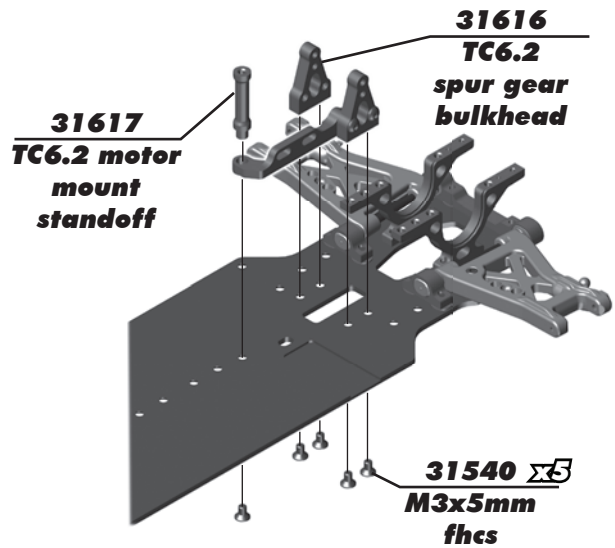
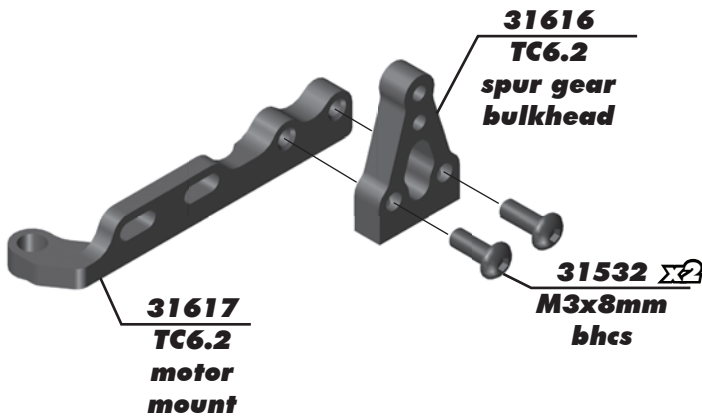

:: Bulkheads, Spur Gear, and Steering Build - Bag E-EE - Step 3

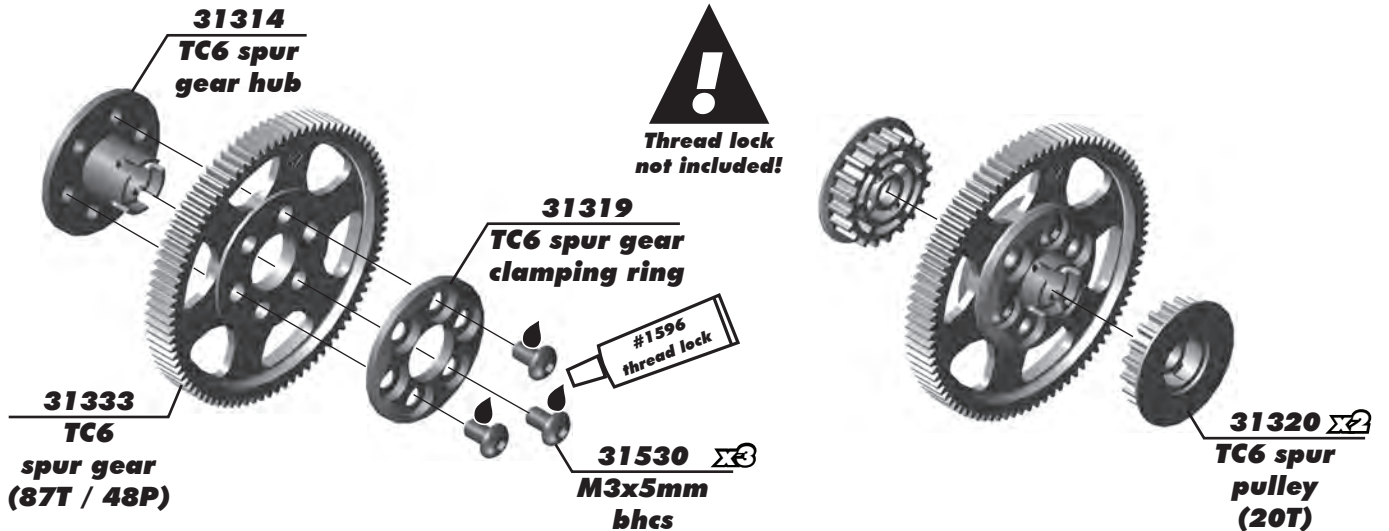

:: Bulkheads, Spur Gear, and Steering Build - Bag E-EE - Step 4

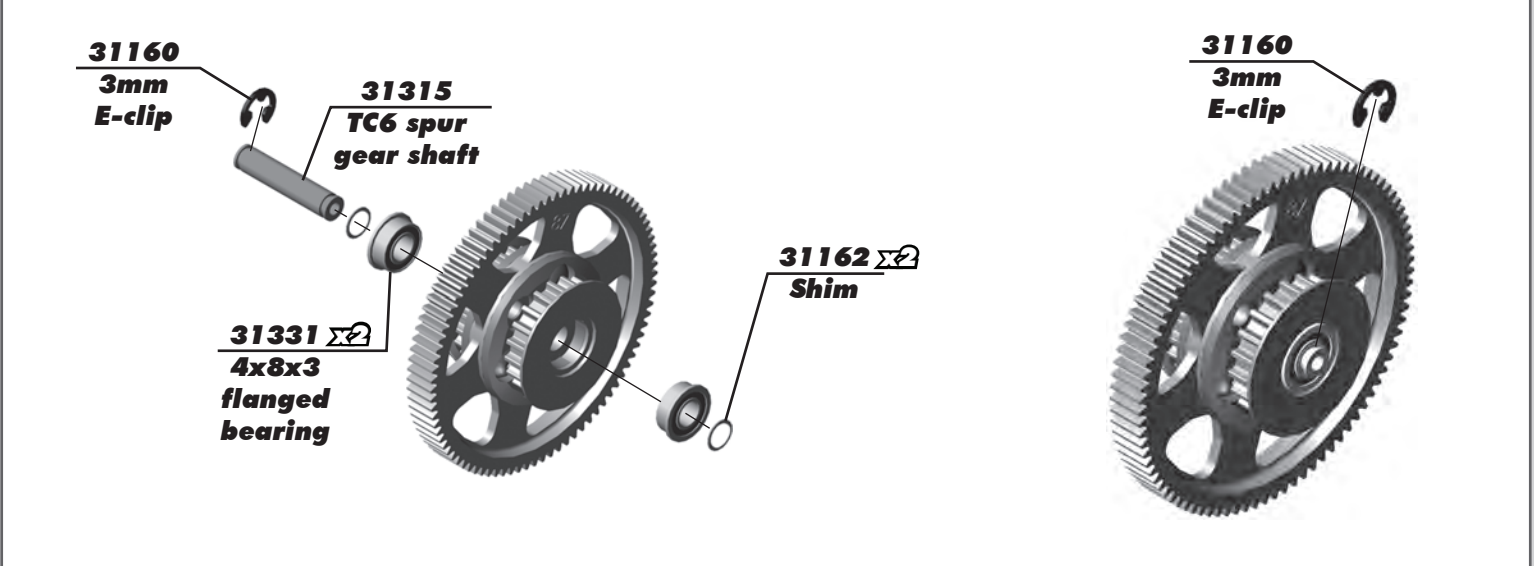

:: Bulkheads, Spur Gear, and Steering Build - Bag E-EE - Step 5

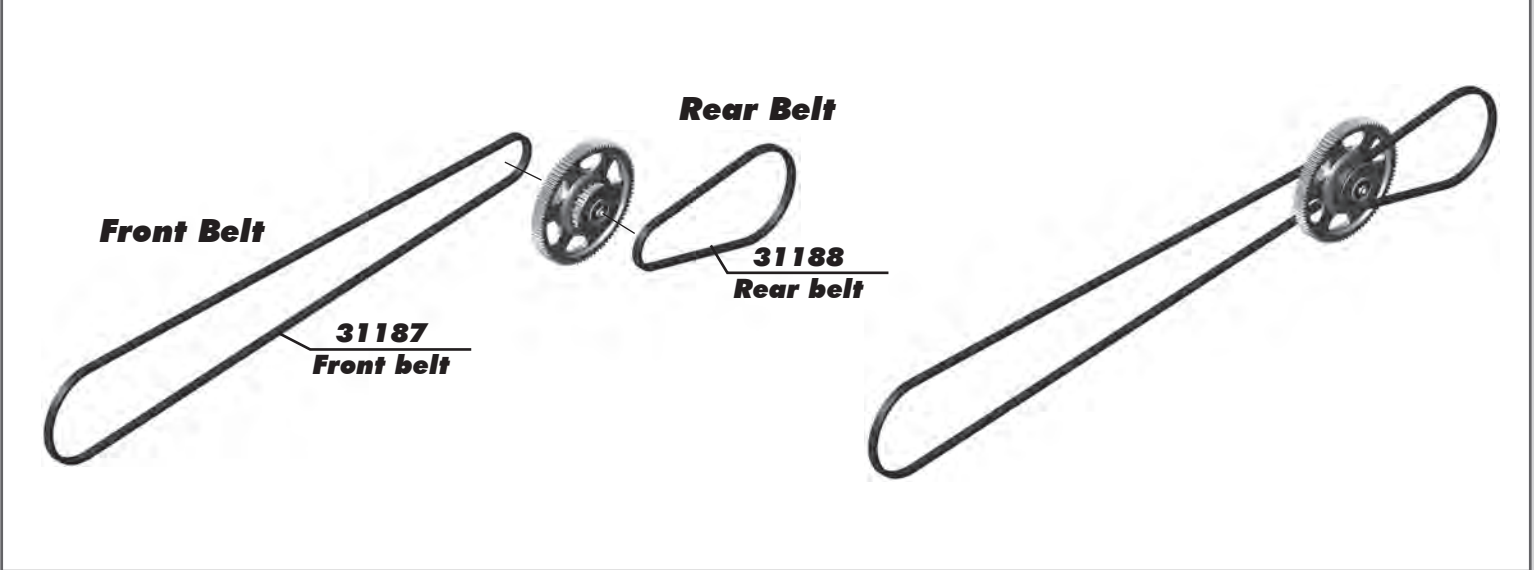

:: Bulkheads, Spur Gear, and Steering Build - Bag E-EE - Step 6

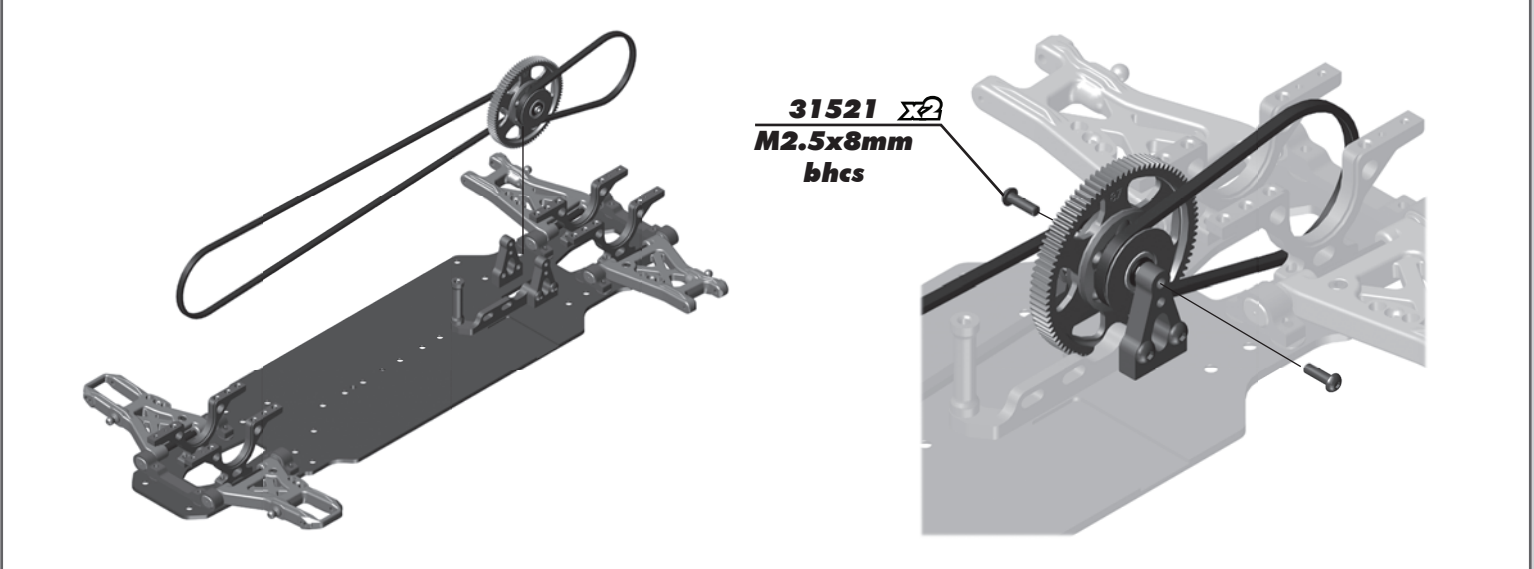

:: Bulkheads, Spur Gear, and Steering Build - Bag E-EE - Step 7

!
Slide belt over
spool pulley!

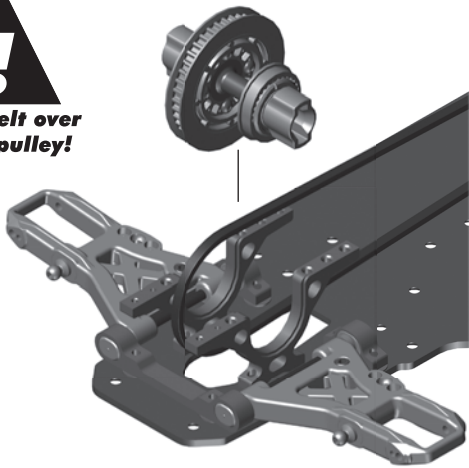

!
Slide belt over
gear diff pulley!

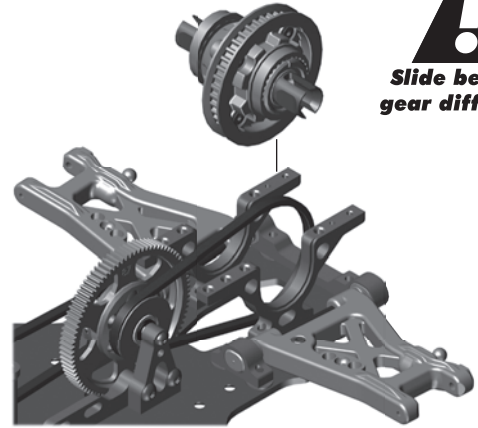

:: Bulkheads, Spur Gear, and Steering Build - Bag E-EE - Step 8

31286 x2
FT ballstud
washer,
aluminum
(2mm)

31280 x2
Ballstud,
short,
5mm

31613
TC6.2
bearing
cap (A)

31614
TC6.2
bearing
cap (B)

31531 x4
M3x6mm
bhcs

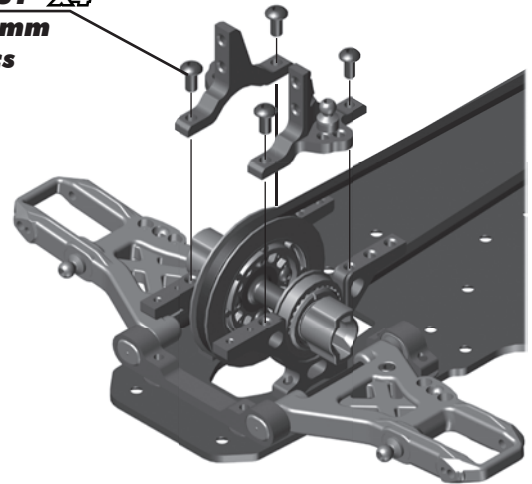

:: Bulkheads, Spur Gear, and Steering Build - Bag E-EE - Step 9

31286 x2
FT ballstud
washer,
aluminum
(1mm)

31280 x2
Ballstud,
short,
5mm

31531 x4
M3x6mm
bhcs

31614
TC6.2
bearing
cap (B)

31613
TC6.2
bearing
cap (A)

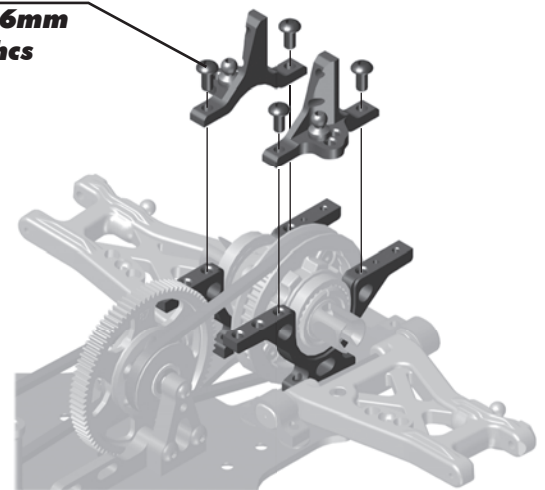

:: Bulkheads, Spur Gear, and Steering Build - Bag E-EE - Step 10

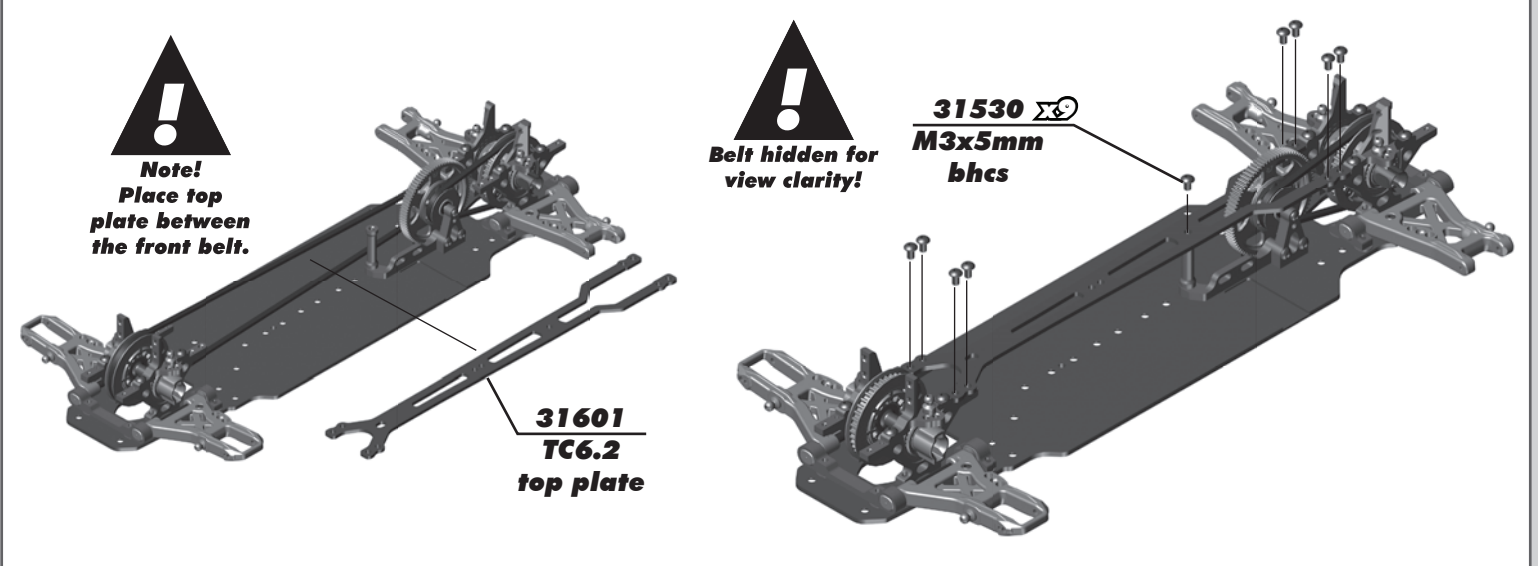

:: Bulkheads, Spur Gear, and Steering Build - Bag E-EE - Step 11

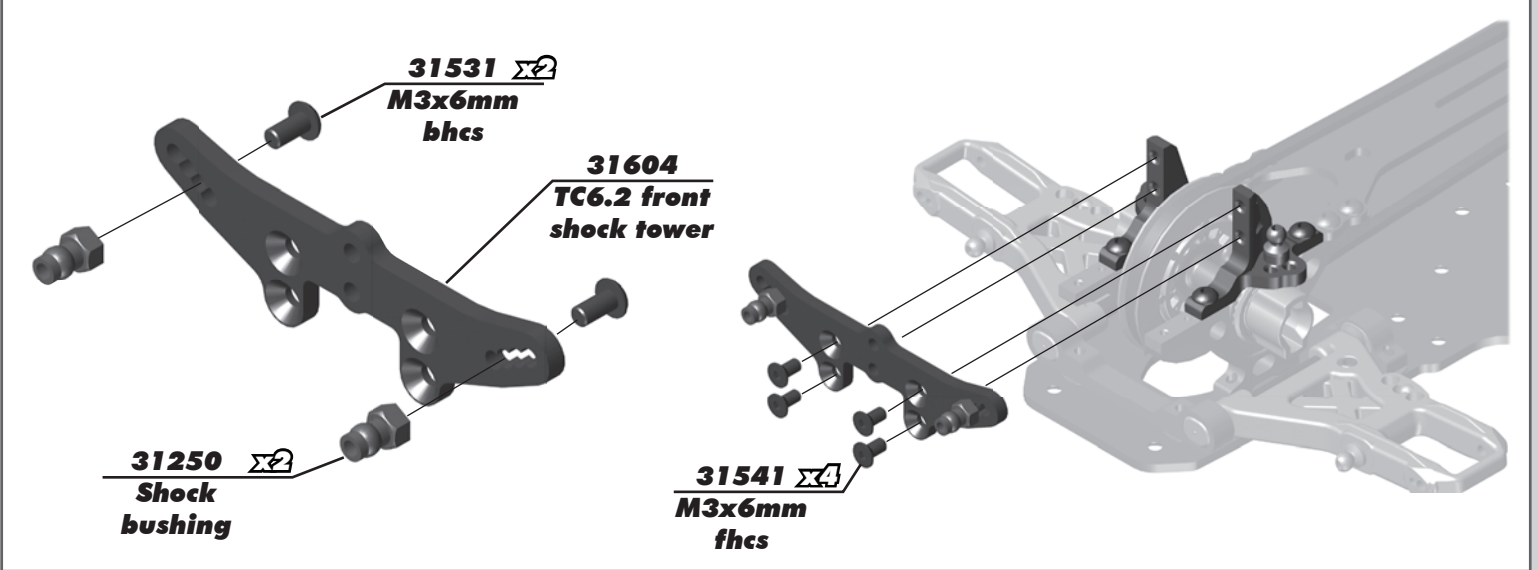

:: Bulkheads, Spur Gear, and Steering Build - Bag E-EE - Step 12

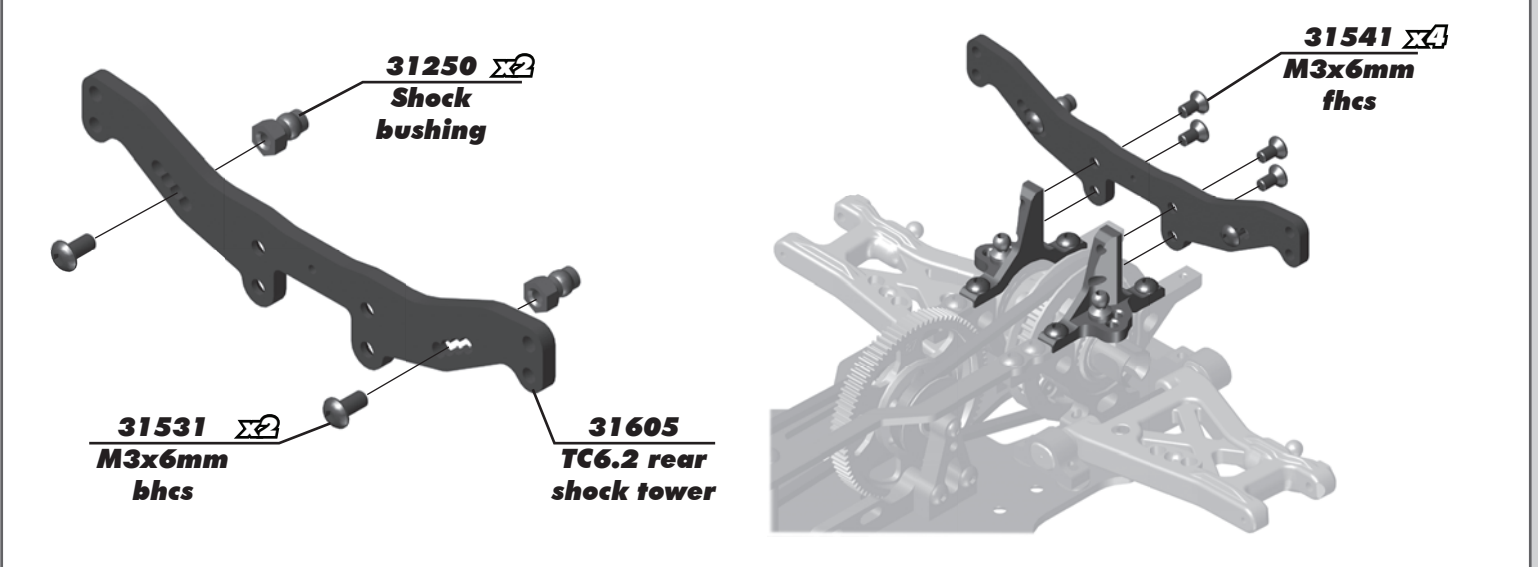

:: Bulkheads, Spur Gear, and Steering Build - Bag E-EE - Step 13

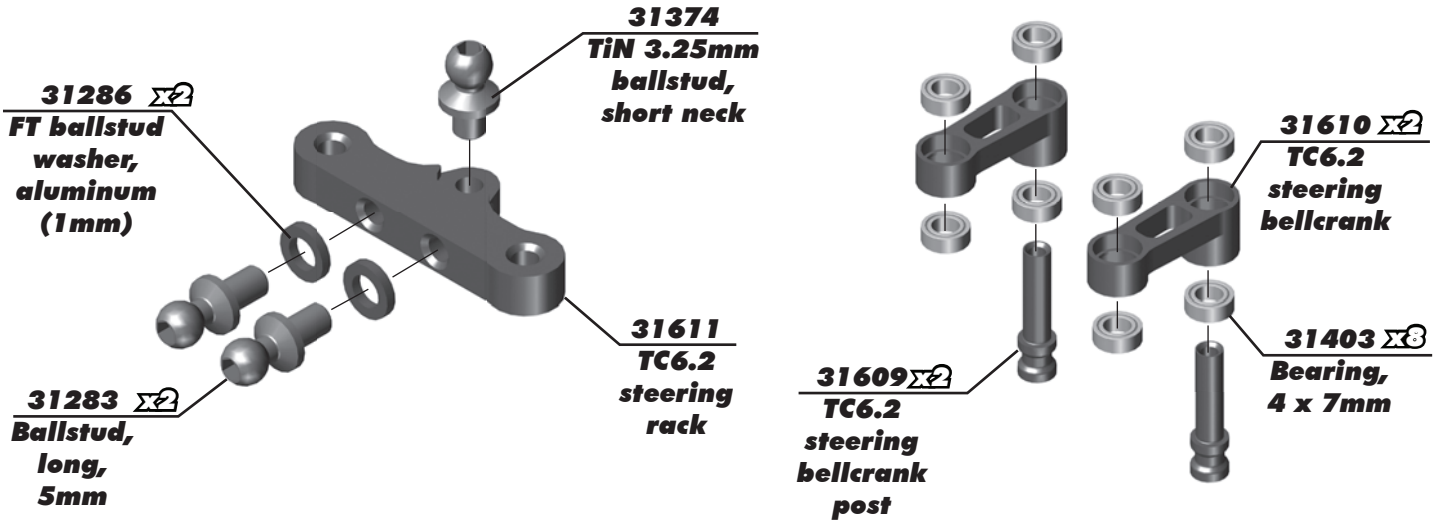

:: Bulkheads, Spur Gear, and Steering Build - Bag E-EE - Step 14

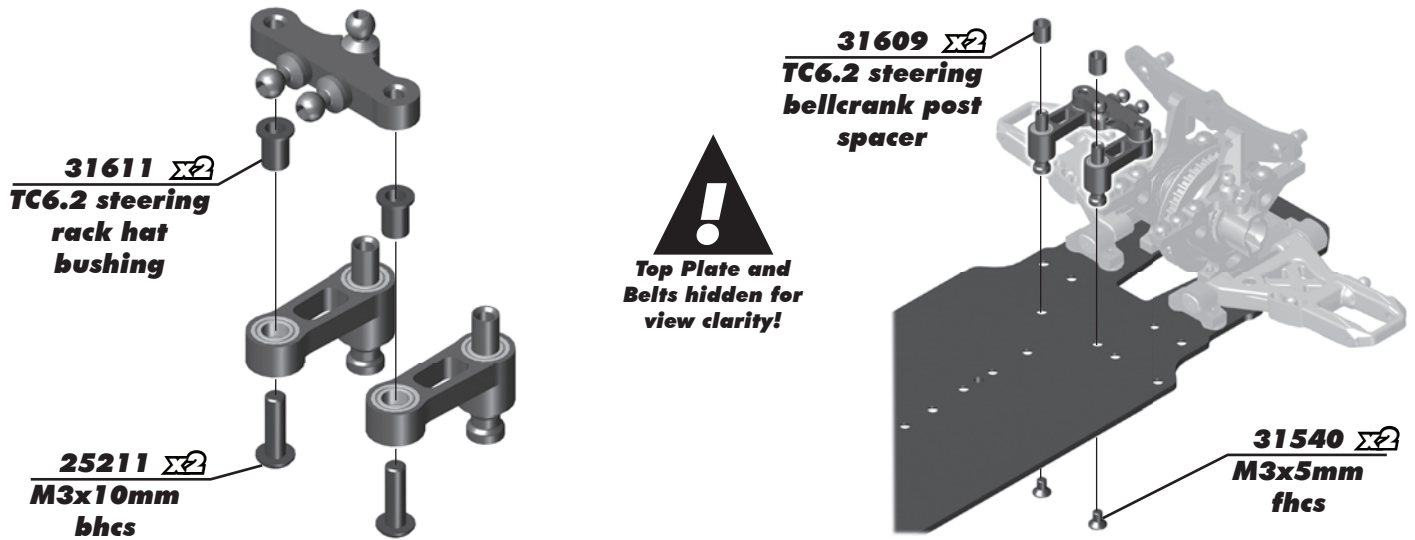

:: Steering / Caster Blocks Build - Bag F - Step 1

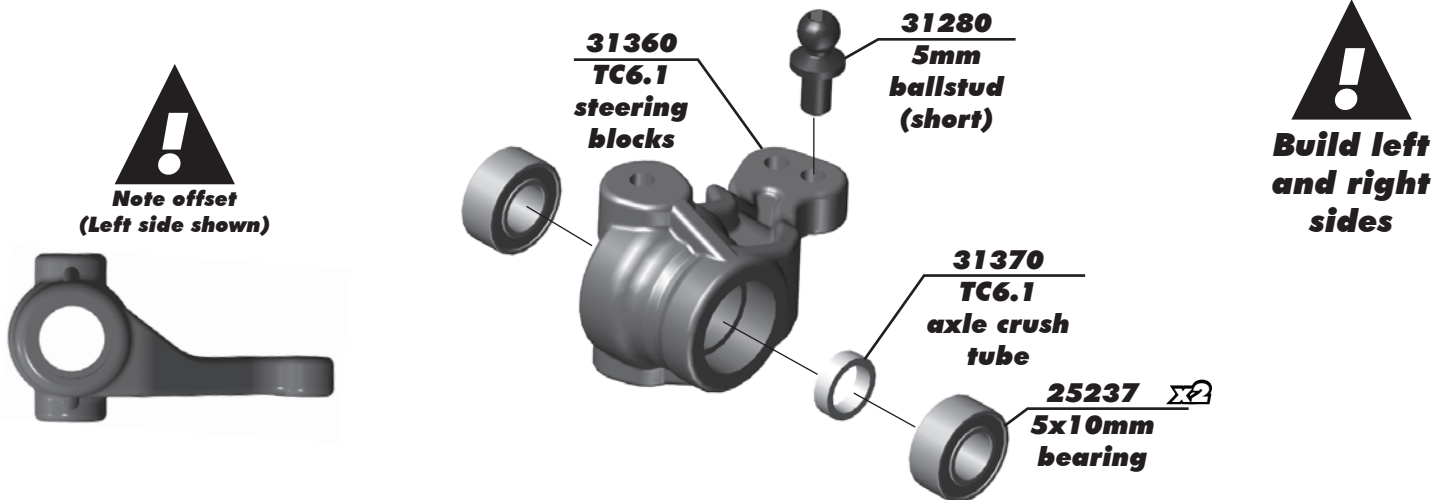

:: Steering / Caster Blocks Build - Bag F - Step 2

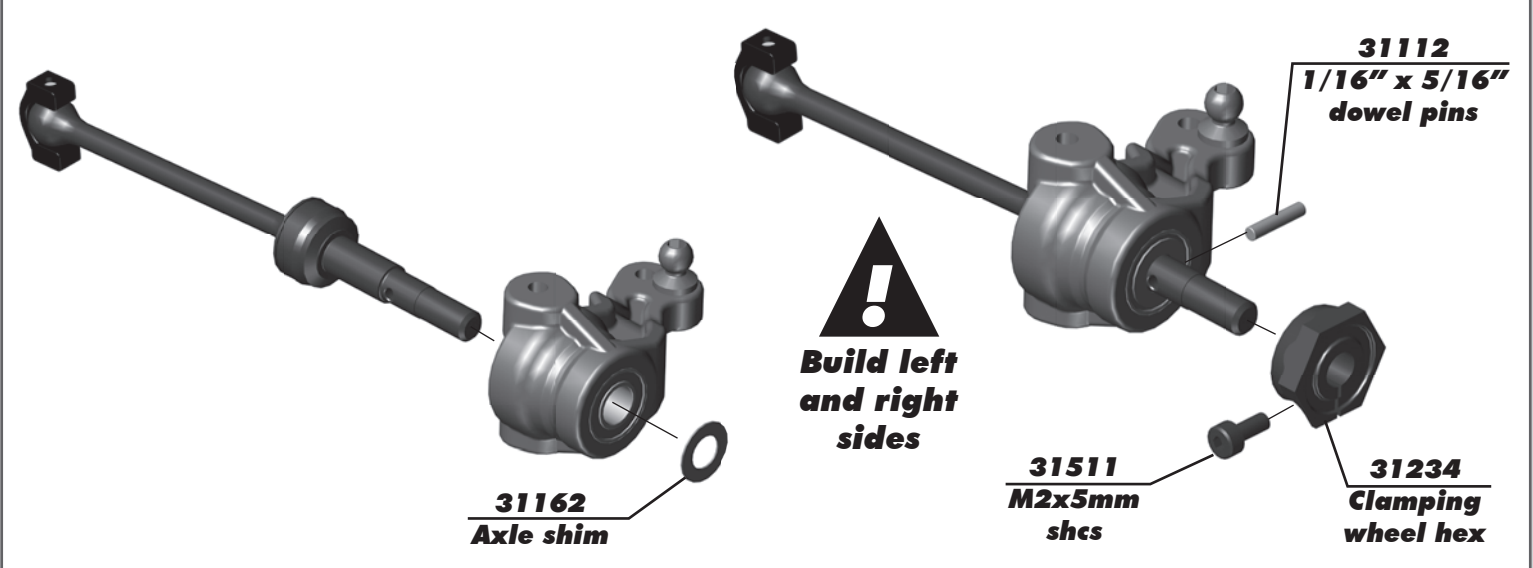

31162
Axle shim

31112
1/16" x 5/16"
dowel pins

31511
M2x5mm
shcs

31234
Clamping
wheel hex

!
**Build left
and right
sides**

:: Steering / Caster Blocks Build - Bag F - Step 3

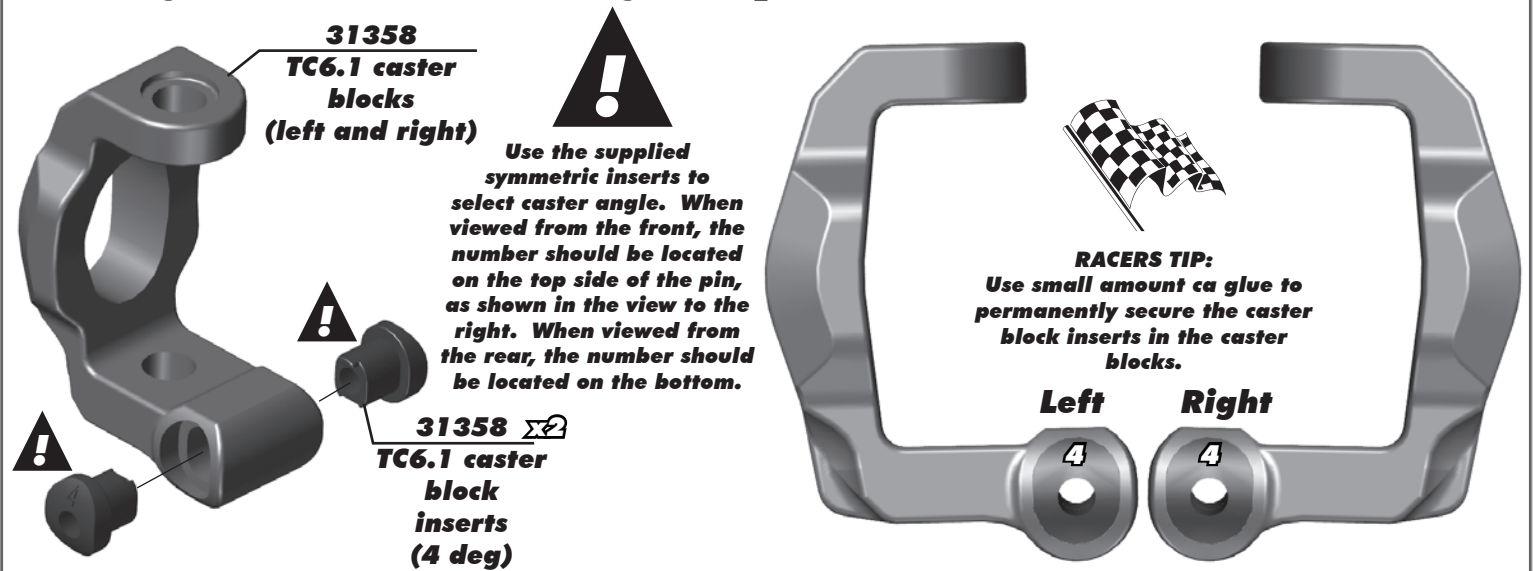

31358
TC6.1 caster
blocks
(left and right)

!

Use the supplied symmetric inserts to select caster angle. When viewed from the front, the number should be located on the top side of the pin, as shown in the view to the right. When viewed from the rear, the number should be located on the bottom.

31358 
TC6.1 caster
block
inserts
(4 deg)

!

RACERS TIP:
Use small amount ca glue to permanently secure the caster block inserts in the caster blocks.

Left **Right**

4 **4**

:: Steering / Caster Blocks Build - Bag F - Step 4

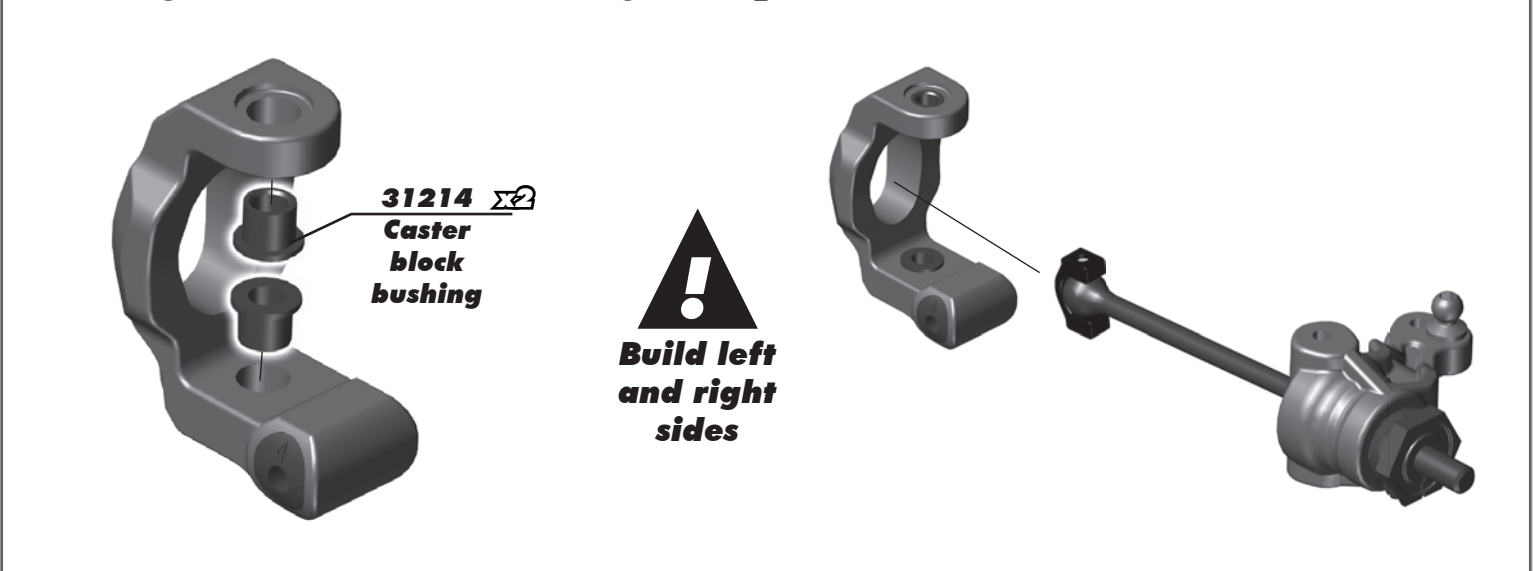

31214 
Caster
block
bushing

!
**Build left
and right
sides**

:: Steering / Caster Blocks Build - Bag F - Step 5

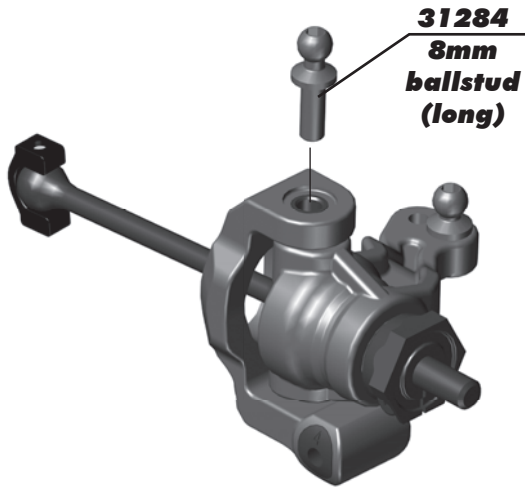

!
**Build left
and right
sides**

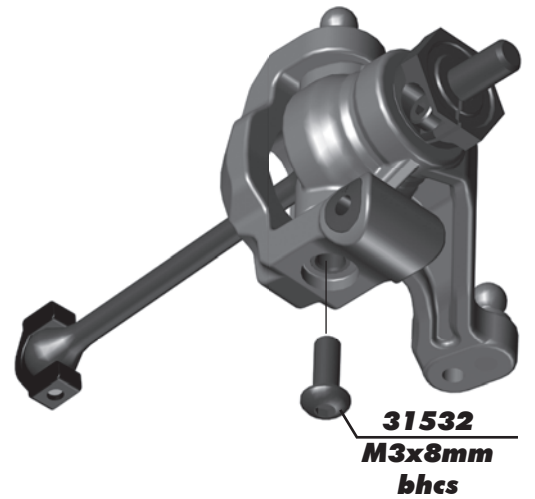

:: Steering / Caster Blocks Build - Bag F - Step 6

!
**Build left
and right
sides**

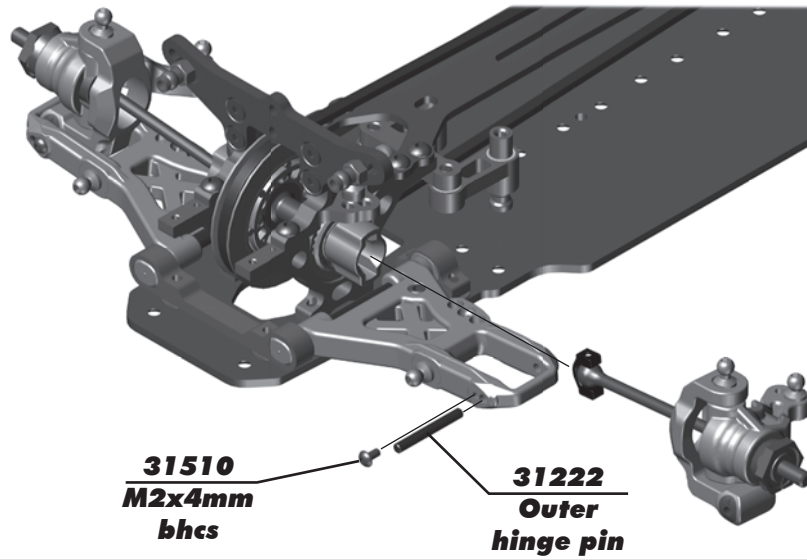

:: Steering / Caster Blocks Build - Bag F - Step 7

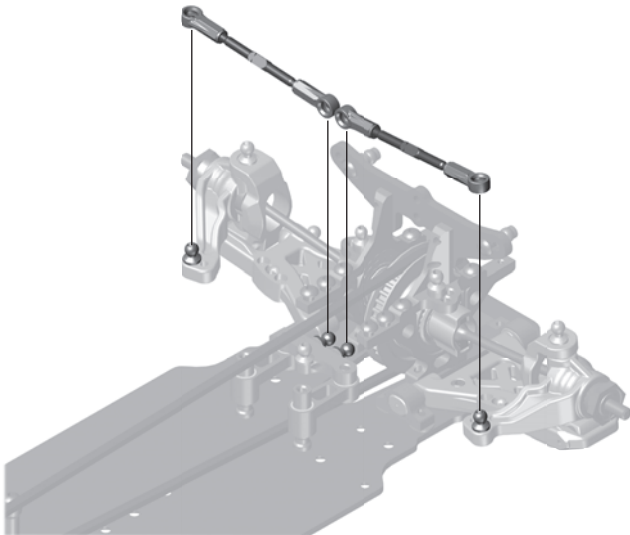

!
**Orient the notch
to the left
throughout
the car. The
notch
indicates
which end
has the
left hand
threads!**

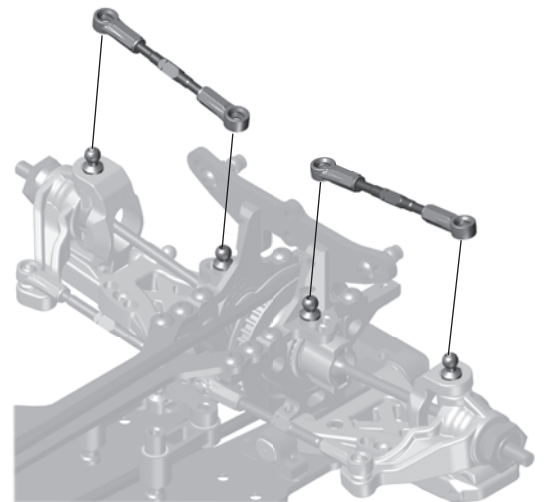

:: Steering / Caster Blocks Build - Bag F - Step 8



It is important that the turnbuckle eyelets move freely once snapped on to the ballstud. If the fit is too tight, the car handling will be inconsistent. To check, grab turnbuckle eyelet with fingers and rotate the cup. If there is resistance, lightly squeeze ball cup with needle nose pliers as shown and test again. It is important that the ball cup be snapped onto the ballstud before squeezing with needle nose pliers. Be sure to check and adjust the fit for each ball cup that is installed.

:: Steering / Caster Blocks Build - Bag F - Step 9

31359 
TC6.1
rear hub
carrier

31359
TC6.1
rear hub
carrier
inserts
(0 deg)

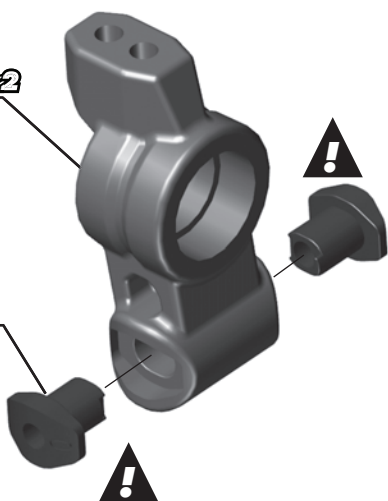

Use the supplied symmetric inserts to select rear hub toe angle. When viewed from the back, the number should be located on the outside of the hinge pin, as shown in the view to the right. When viewed from the front, the number should be located on the inside of the hinge pin.



Left



RACERS TIP:
Use small amount of ca glue to permanently secure the rear hub inserts in the hubs.

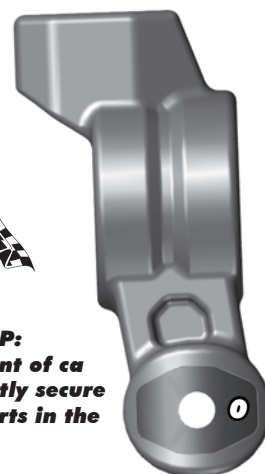

Right

:: Steering / Caster Blocks Build - Bag F - Step 10

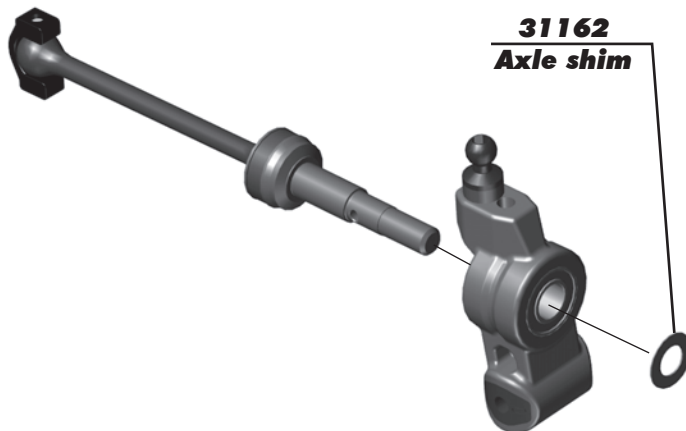
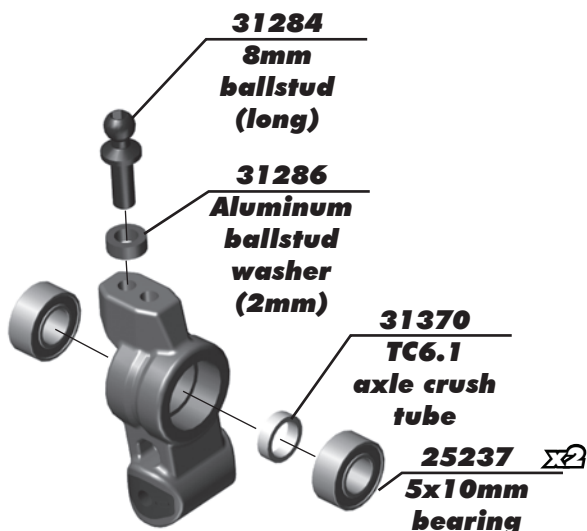

:: Steering / Caster Blocks Build - Bag F - Step 11

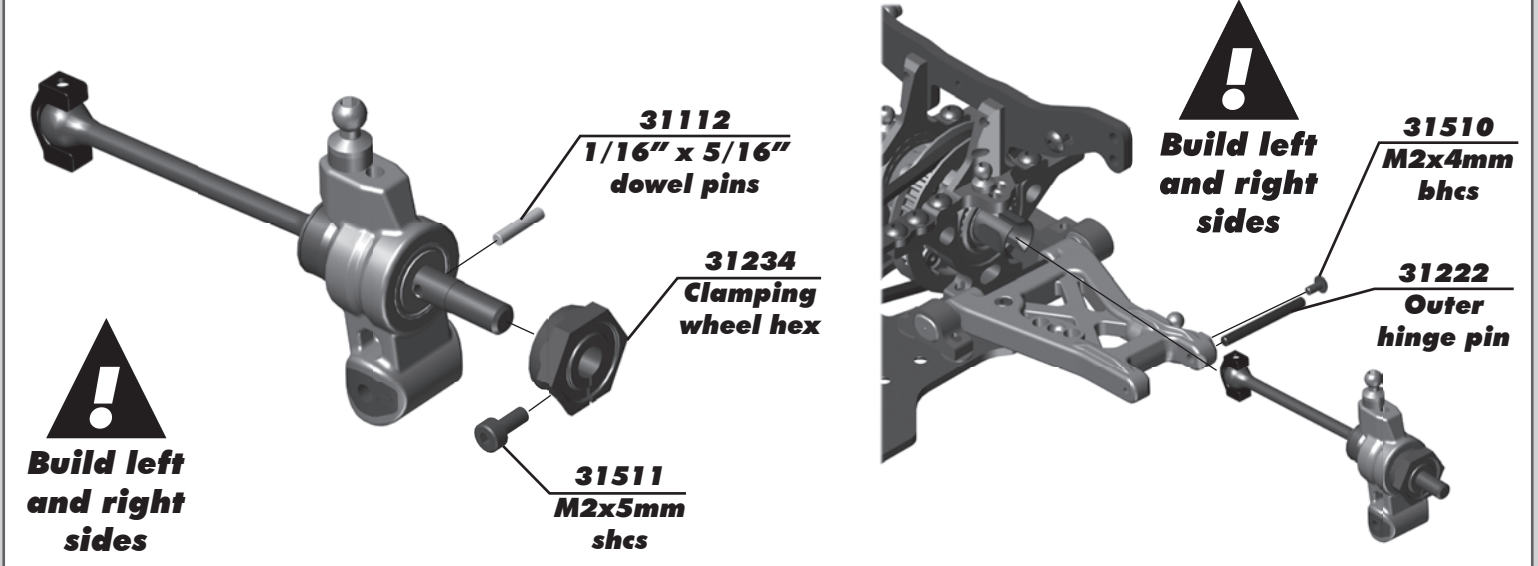

:: Steering / Caster Blocks Build - Bag F - Step 12

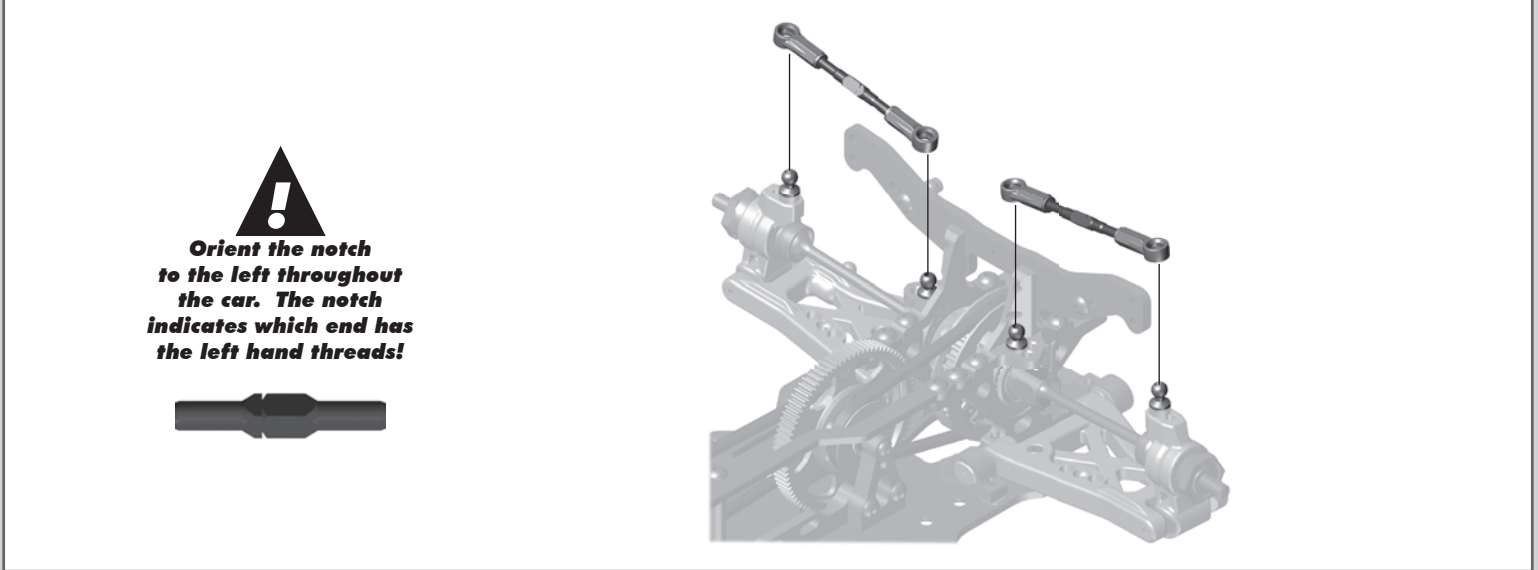

:: Steering / Caster Blocks Build - Bag F - Step 13

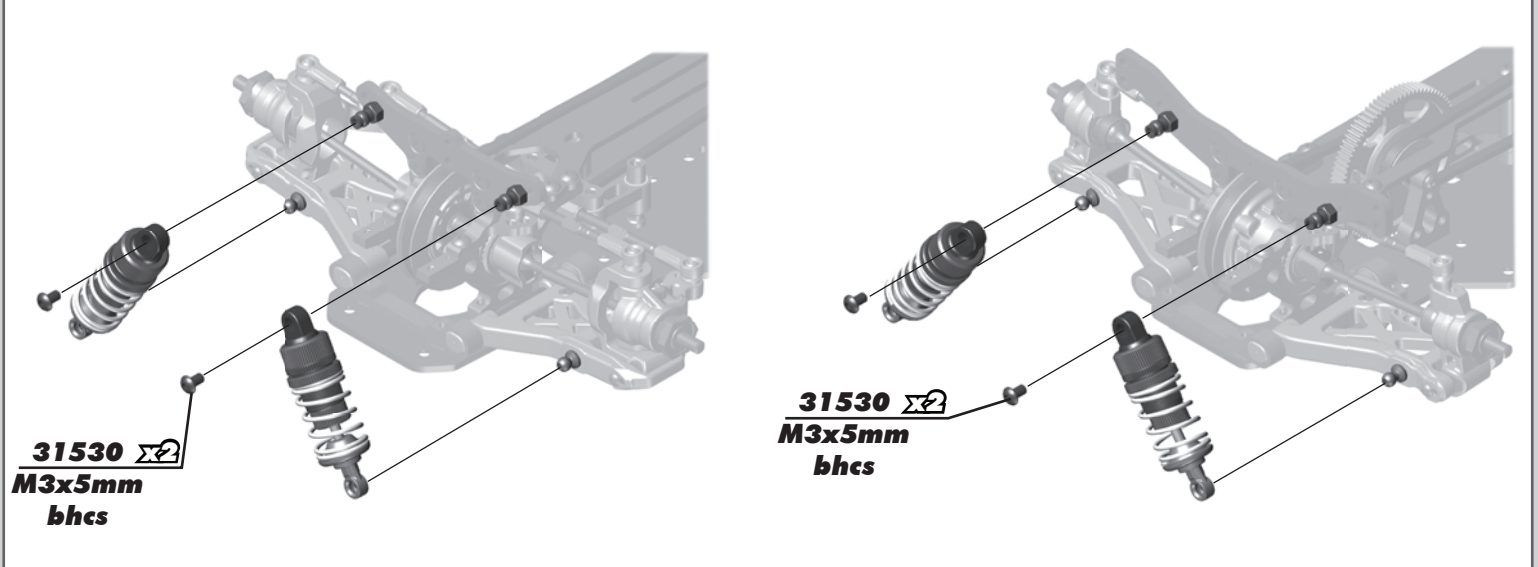

:: Bumper, Anti-Roll Bar and Electronics Build - Bag G-GG - Step 1

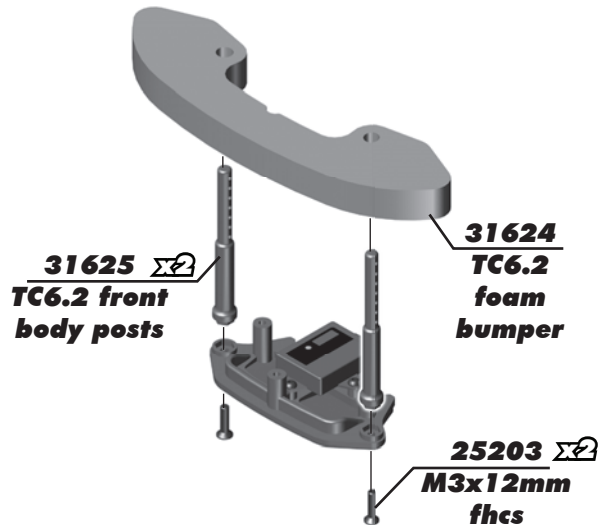
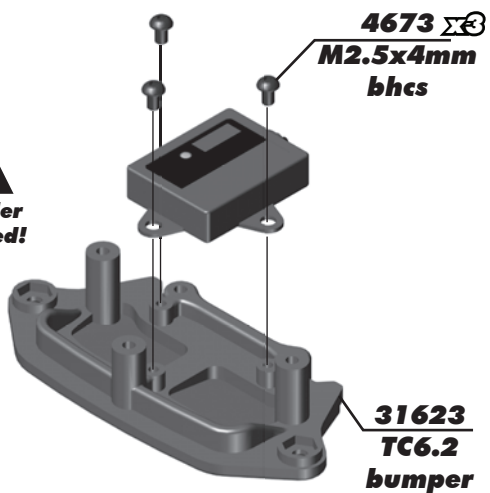

:: Bumper, Anti-Roll Bar and Electronics Build - Bag G-GG - Step 2

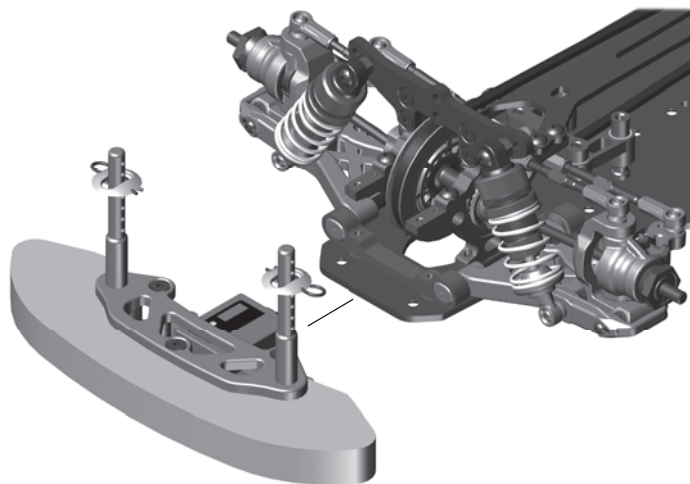
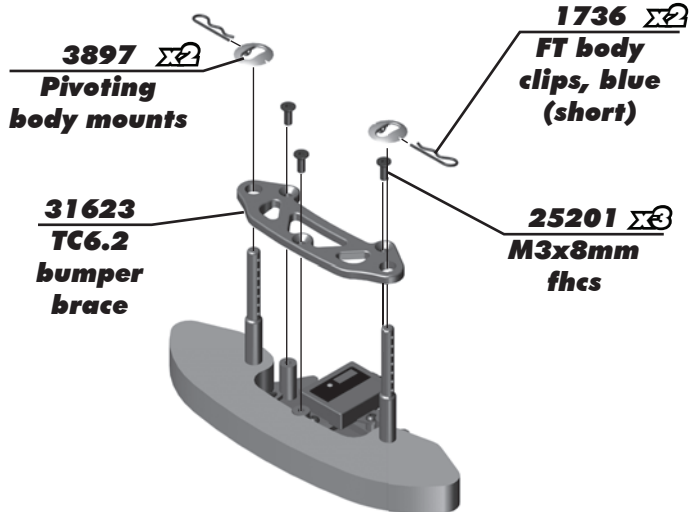

:: Bumper, Anti-Roll Bar and Electronics Build - Bag G-GG - Step 3

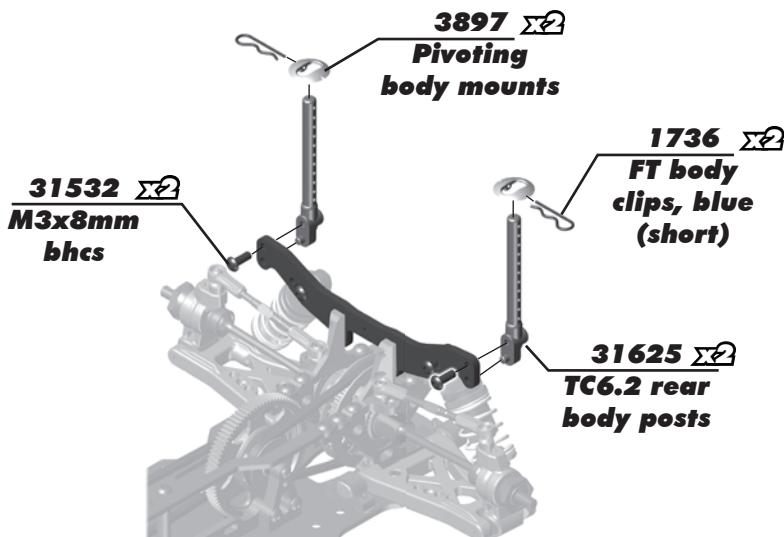
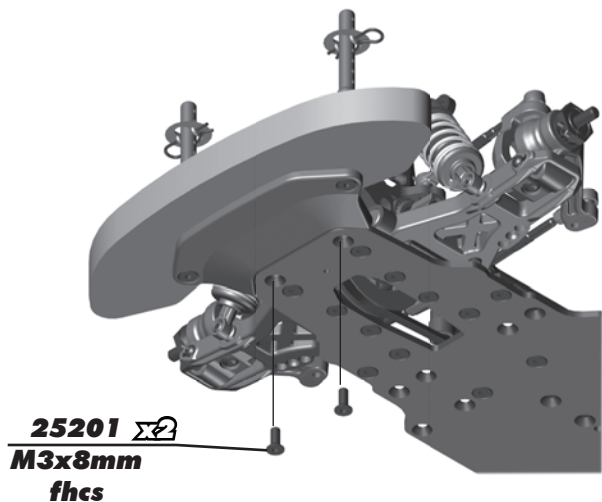

:: Bumper, Anti-Roll Bar and Electronics Build - Bag G-GG - Step 4

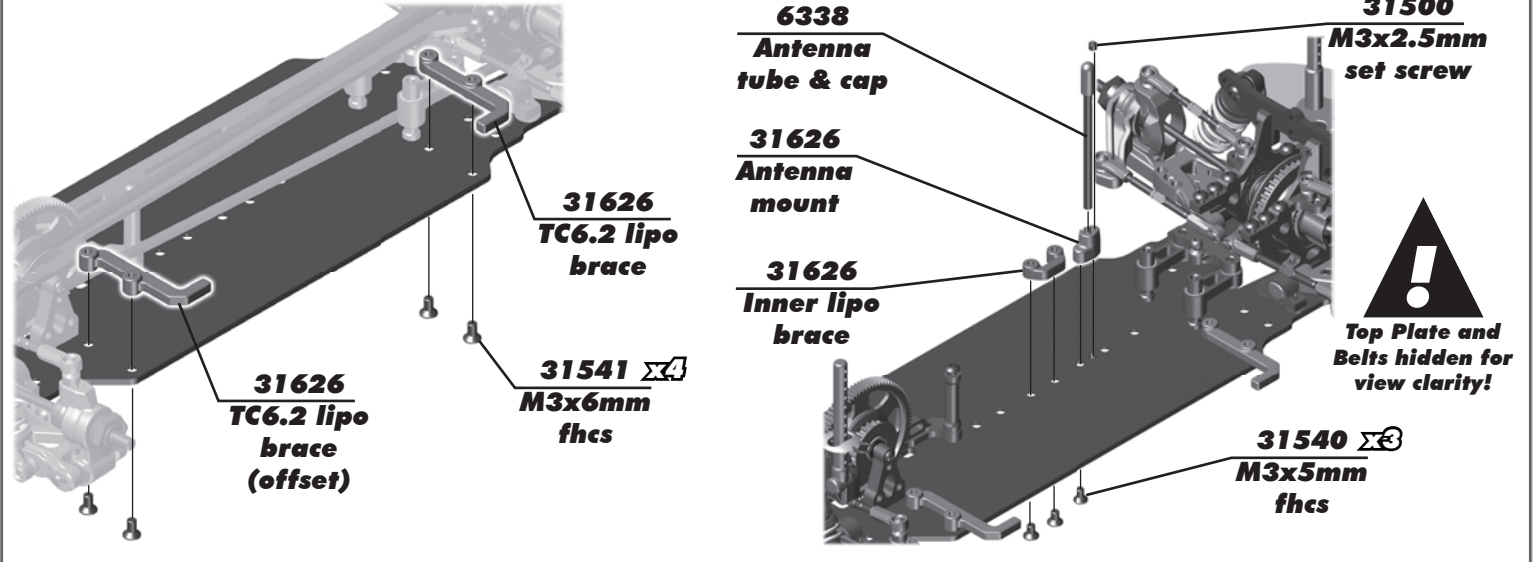

:: Bumper, Anti-Roll Bar and Electronics Build - Bag G-GG - Step 5

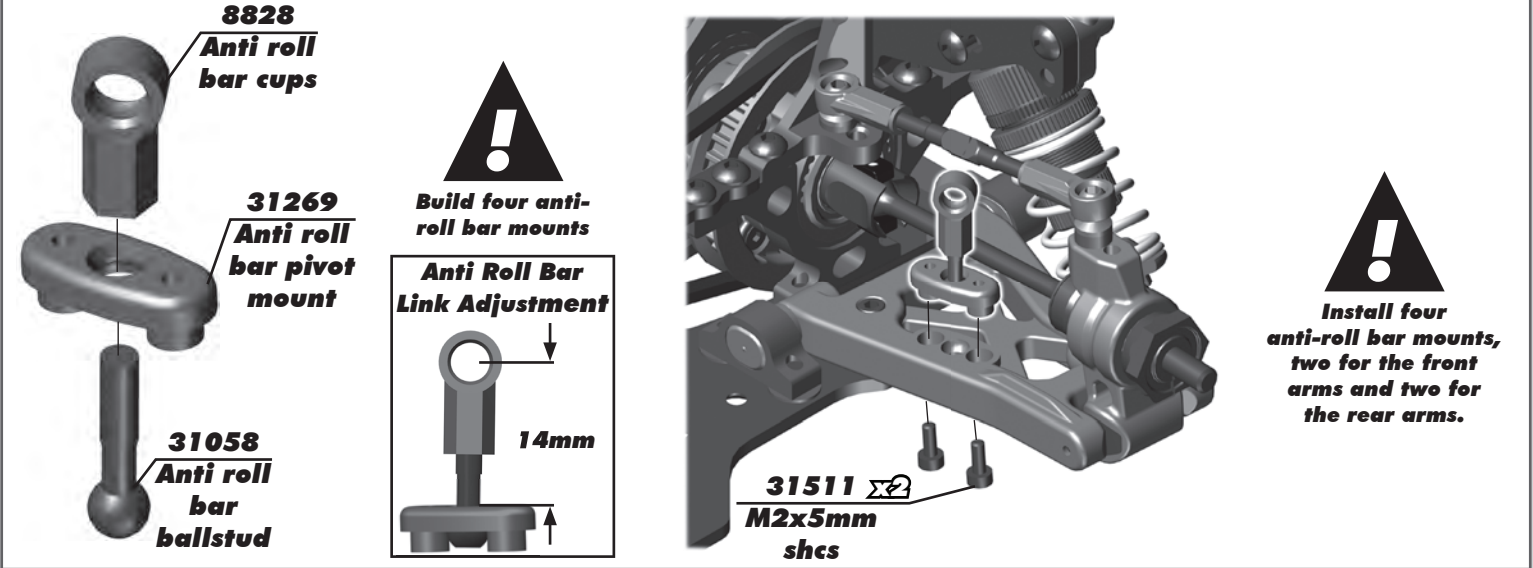

:: Bumper, Anti-Roll Bar and Electronics Build - Bag G-GG - Step 6

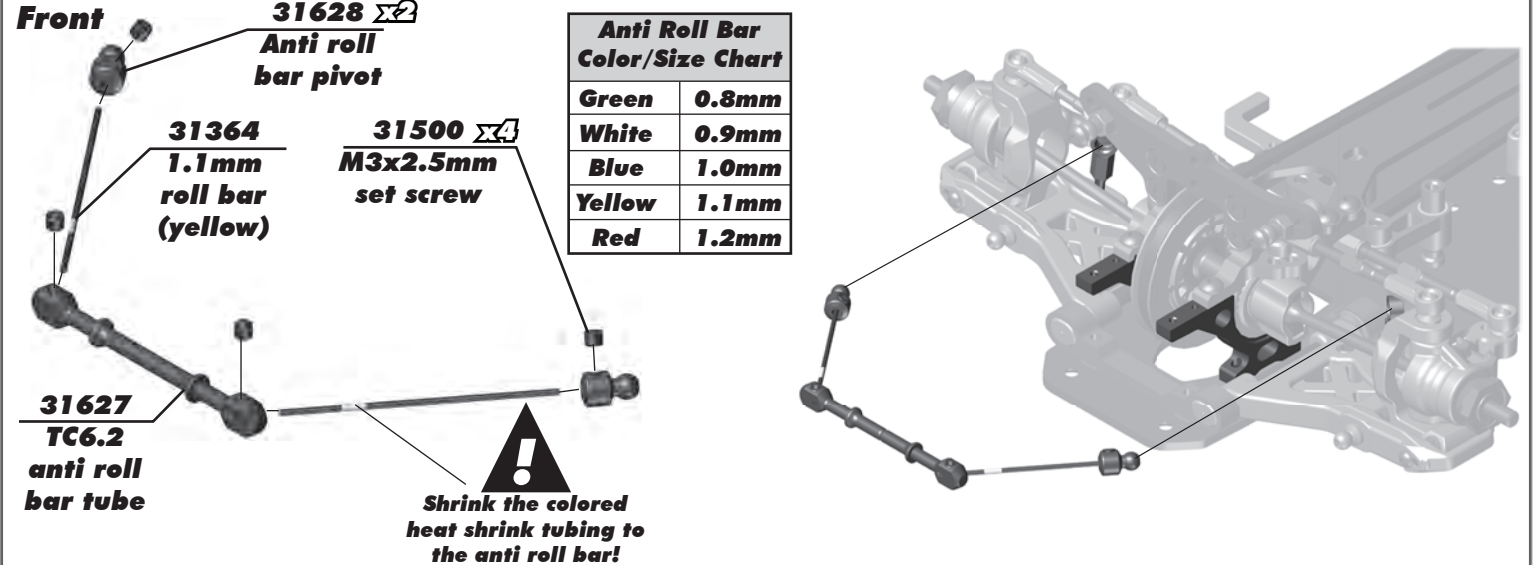

:: Bumper, Anti-Roll Bar and Electronics Build - Bag G-GG - Step 7

31511 **M2x5mm shcs**

31365 **Anti roll bar mounts**

31628 **Anti roll bar pivot**

31364 **0.9mm roll bar (white)**

31500 **M3x2.5mm set screw**

31627 **TC6.2 anti roll bar tube**

Anti Roll Bar Color/Size Chart

Green	0.8mm
White	0.9mm
Blue	1.0mm
Yellow	1.1mm
Red	1.2mm

Shrink the colored heat shrink tubing to the anti roll bar!

:: Bumper, Anti-Roll Bar and Electronics Build - Bag G-GG - Step 8

31365 **Anti roll bar mounts**

31511 **M2x5mm shcs**

:: Bumper, Anti-Roll Bar and Electronics Build - Bag G-GG - Step 9

Steering Servo Chart

Associated	XP-1015, XP-1313	# 89007 servo arm
Airtronics	94102	A
Airtronics	94738, 94157, 94158, 94257, 94258, 94357, 94358, 94452, 94453, 94751, 94755	A
Hitec	HS-5625MG, HS-5645MG, HS625MG, HS645MG	H
Hitec	HS-322HD, HS-325HB, HS-965, HS-985MG, HS-5965, HS-5985MG, HS-425BB, HS-422	H
JR	Z4725, Z4750, Z2750, Z8450, Z8550, NES-4750	J
JR	Z250, Z550	J
Futaba	S9204, S9250, S9450, S148	F
Futaba	S3003, S9202, S9101	F
Futaba	S9404	F
KO	PS-401, PS-2001, PS-2004, PS-2015, PS-2173, PS-2174, PS-2123, PS-2143, PS-2144	J

31286 **Aluminum ballstud washer (1mm, 2mm)**

31285 **10mm ballstud (long)**

31550 **FT M3 Locknut, blue aluminum**

89007 **Servo horn ring**

89007 **Servo horn**

Drill top hole to 2.5mm, then install ballstud and locknut

* Not all servo's are listed
 * Make sure servo linkage clears the servo through full travel in both directions. Use #7336 servo spacers to adjust servos position as necessary.

:: Bumper, Anti-Roll Bar and Electronics Build - Bag G-GG - Step 10

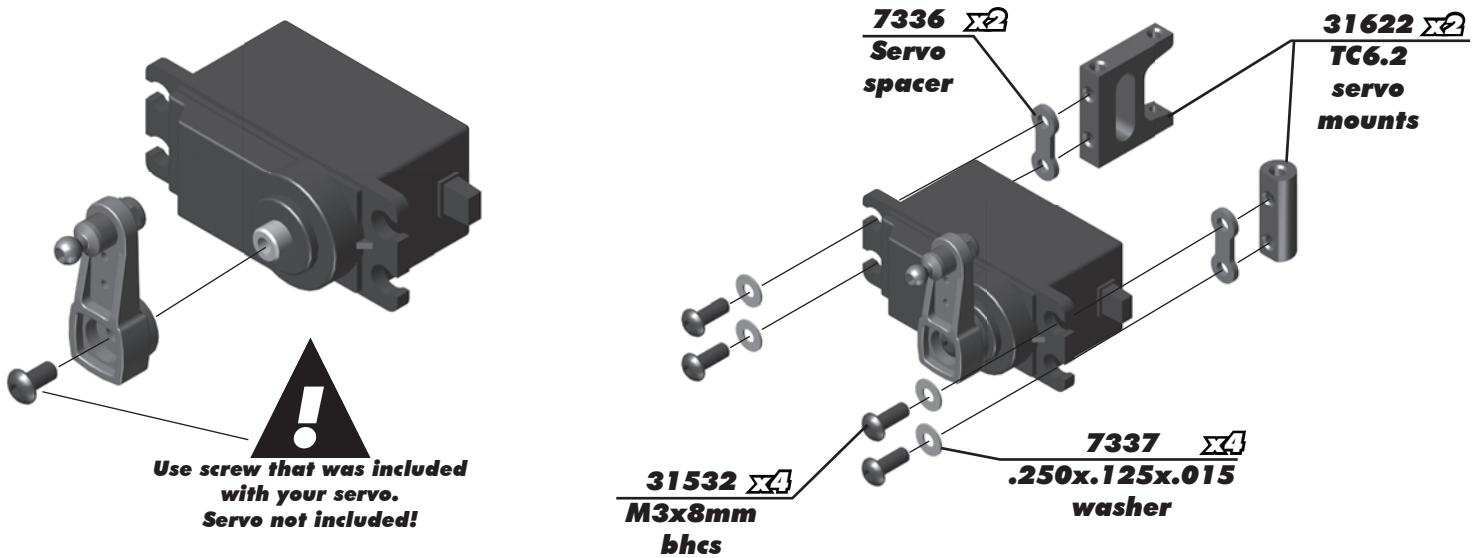

:: Bumper, Anti-Roll Bar and Electronics Build - Bag G-GG - Step 11

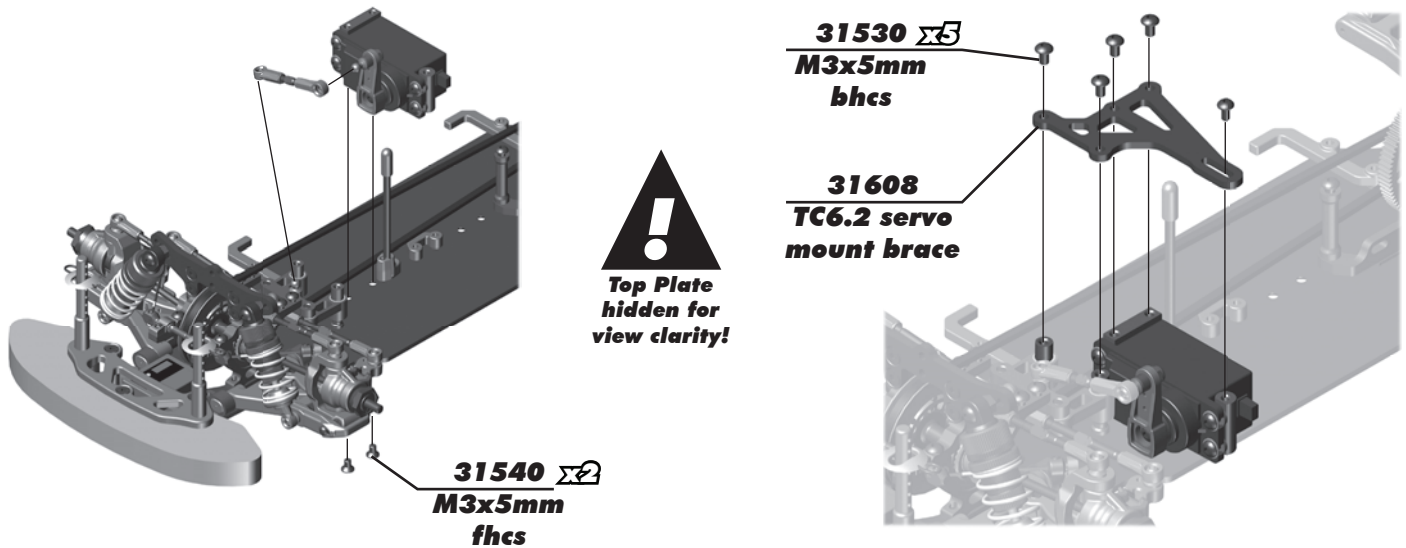

:: Bumper, Anti-Roll Bar and Electronics Build - Bag G-GG - Step 12

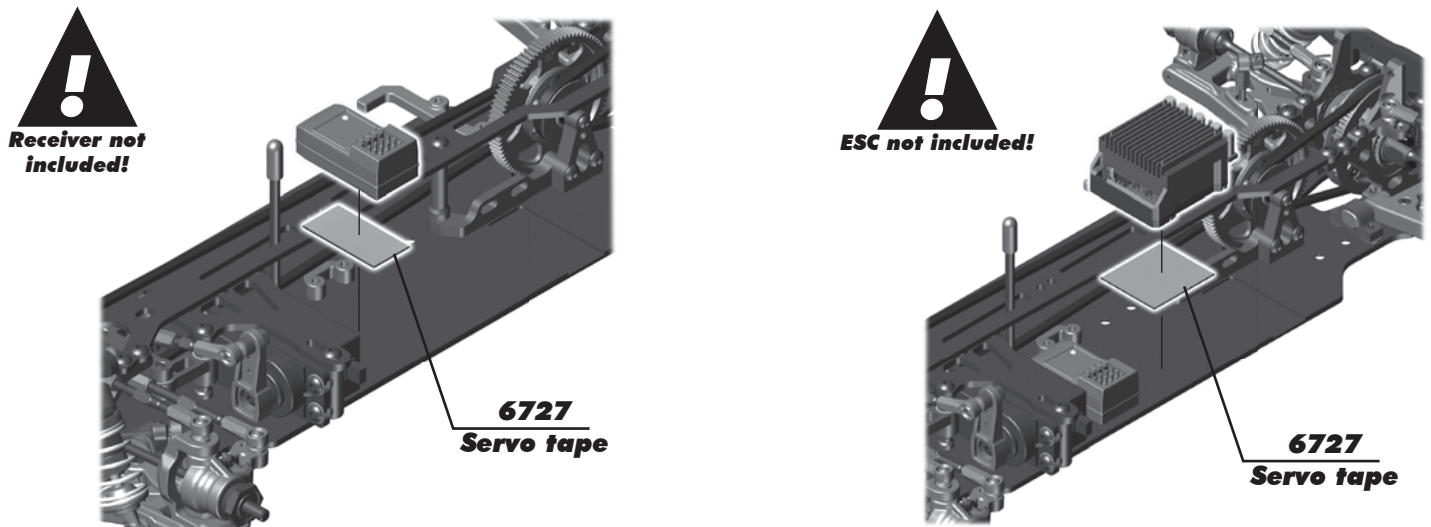

:: Bumper, Anti-Roll Bar and Electronics Build - Bag G-GG - Step 13

Gearing will depend on the motor and track size.
Gear chart on page 29.
Motor, pinion gear, and set screw are not included!

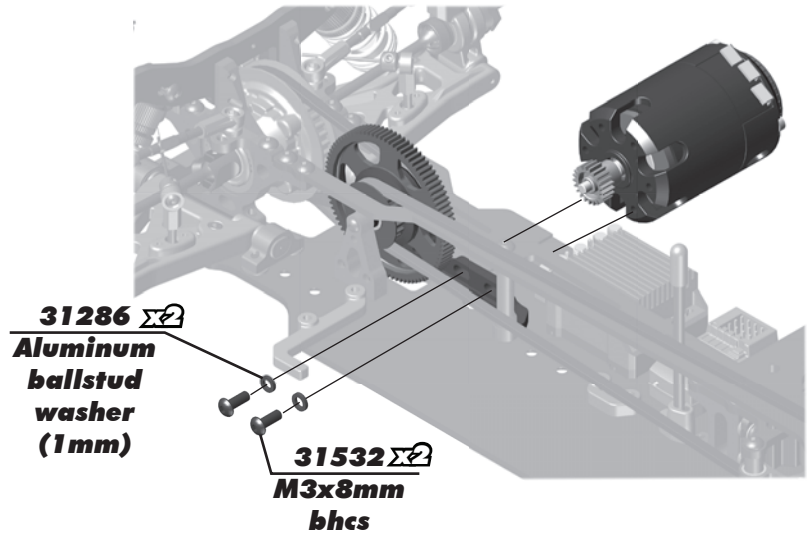
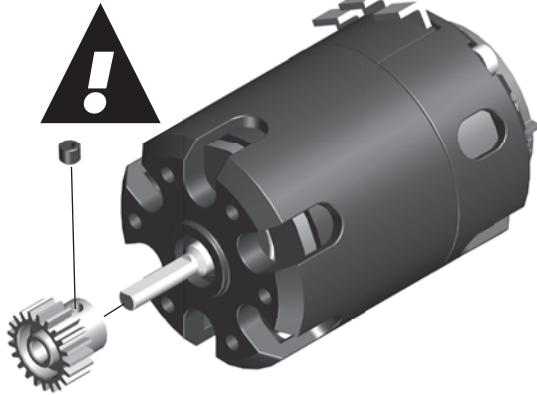

:: Bumper, Anti-Roll Bar and Electronics Build - Bag G-GG - Step 14

!
Use strapping tape to secure battery into chassis. Wrap the tape around the #31626 LiPo brace an back onto itself. Battery tape not included!

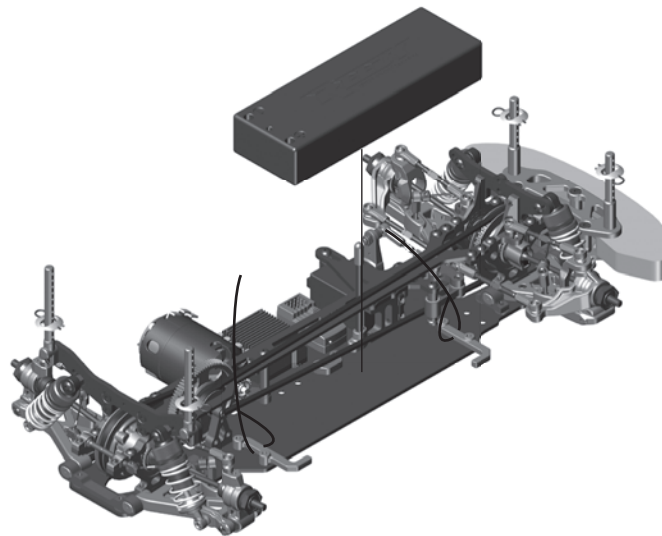

!
Battery and strapping tape not included!

:: Bumper, Anti-Roll Bar and Electronics Build - Bag G-GG - Step 15

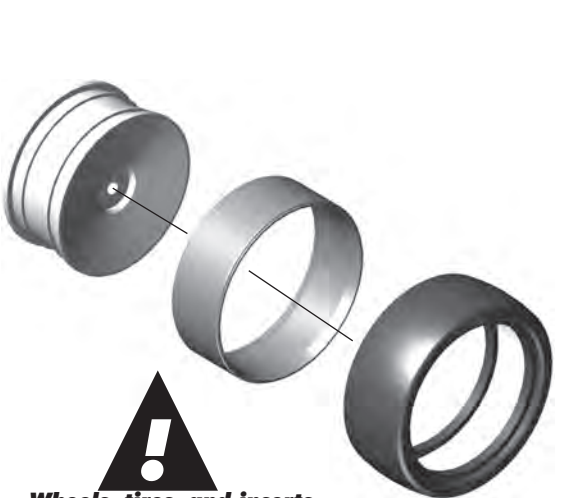

!
Wheels, tires, and inserts not included!

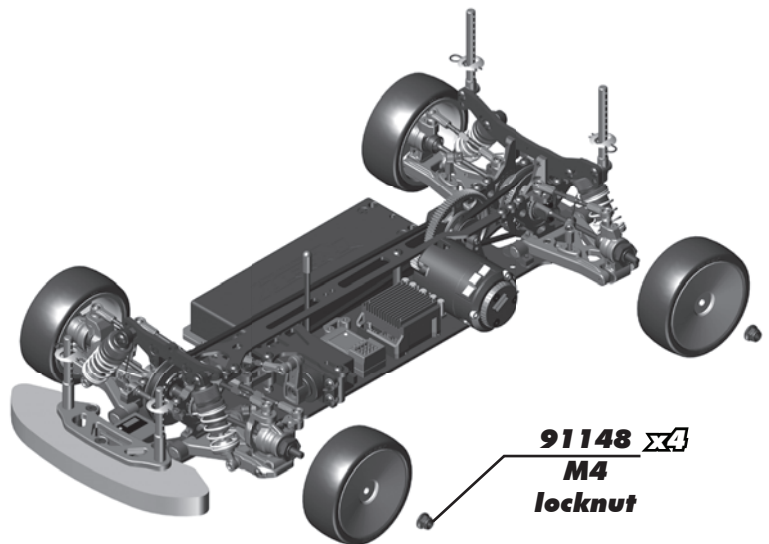

91148 $\times 4$
M4
locknut

:: Tuning Tips

Tips for Beginners:

Before making any changes to the standard setup, make sure you can get around the track without crashing. Changes to your car will not be beneficial if you can't stay on the track. Your goal is consistent laps.

Once you can get around the track consistently, start tuning your car. Make only ONE adjustment at a time, testing it before making another change. If the result of your adjustment is a faster lap, mark the change on the included setup sheet (make additional copies of the sheet before writing on it). If your adjustment results in a slower lap, revert back to the previous setup and try another change.

When you are satisfied with your car, fill in the setup sheet thoroughly and file it away. Use this as a guide for future track days or conditions.

Ride Height:

The standard starting point for ride height is 5.0mm (keep in mind that your local track may have minimum ride height requirements). You can slightly raise the rear relative to the front to give the car more steering. Raise the car slightly for tracks with large bumps.

Battery Placement:

For most cases, run the battery in the standard forward position. Typically this will be the most stable and easiest to drive. Try moving the battery back if you encounter a low traction surface by switching LiPo braces front to back.

Wheelbase:

Lengthening the front will reduce steering, shortening the front will increase steering. Shortening the rear will increase rear grip, lengthening the rear will decrease rear traction.

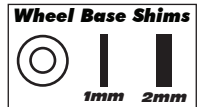

Rear Toe-In:

The TC6.2 allows rear toe adjustments in two positions: inner hinge pin, and outer hinge pin at the rear hub. In general, decreasing rear toe-in will decrease rear traction and increase corner speed.

Rear toe-in can be adjusted by 0.5° increments at the inner hinge pin with supplied arm mount inserts (see chart to right). Standard toe-in angle for inner hinge pin when using same insert front and rear is 3°. Standard insert used is 1 dot.

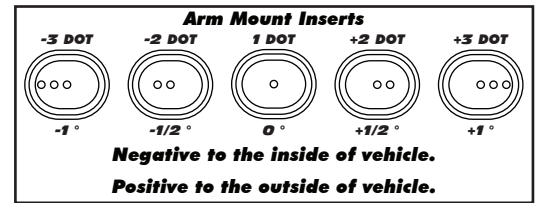

Use rear hub inserts to change toe at the outer hinge pin by 0.5° increments. Note the number on hub insert should be on outside of hinge pin for proper installation.

Ackermann & Steering Rate:

Ackermann refers to the relative angle difference between the front wheels as they are turned to steer the car. The outside wheel will turn less than the inside wheel in most conditions. Settings with more Ackermann will have a bigger difference in wheel angle, causing the outside wheel to turn less. Likewise, settings with less Ackermann will cause the outside wheel to turn more.

Increasing the Ackermann will smooth out the steering and is used most often on high traction surfaces such as carpet. This is a result of the reduced outside wheel angle. Settings with reduced Ackermann will help to increase corner entry steering, and are typically used when running a spool in the front.

The chart to the right lists the different Ackermann options.

Steering Block Position	Steering Rack Shims	Ackermann
B	2mm	Less Ackermann ↑
B	1mm	STD
B	0mm	More Ackermann ↓
A	2mm	
A	1mm	
A	0mm	

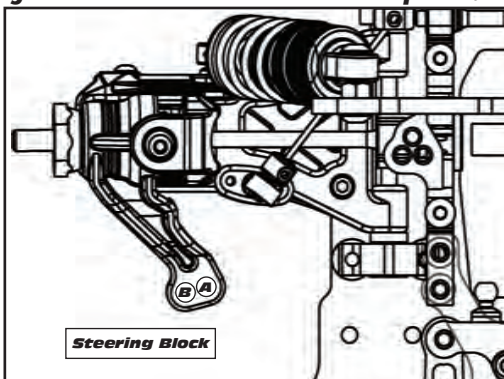

:: Tuning Tips

Caster:

Caster describes the angle of the kingpin from vertical while looking from the side of the car. Positive caster means the top of the kingpin leans rearward. Negative caster means the kingpin is leaning towards the front of the car. Since caster is measured at the wheel, it is affected by running any inclination in your inner arm mount. Kick-up adds (+) caster, and anti-dive adds (-) caster.

When figuring out your caster at the wheel, add the number of degrees of kick-up or anti-dive and add it to the degree caster blocks you have on the car.

Typically for most racing surfaces, 4 degrees caster is the normal starting point for the Team. From there, increase caster to reduce mid to exit steering and make the front end less responsive. Conversely, decreased caster gives a more responsive feel and more exit steering.

Drop:

The standard settings of 6mm front and 5mm rear will work best in most cases. Droop is measured just underneath the outer hinge pin as shown in the photos to the right.

On bumpy or low grip surfaces, increase the droop (going to a lower number on the droop gauge), this will help increase traction and consistency.

Droop adjustments of 0.5mm to 1mm can be very effective on the track!

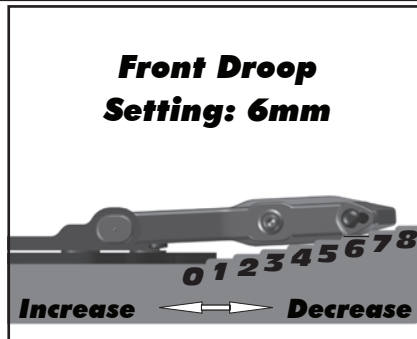

Camber Link Position:

The camber link is used to set static camber at ride height, but it is also an effective setting to adjust roll center height and camber gain. The TC6.2 has three optimized length positions at the front, and six at the rear, for a wide range of camber gain adjustments. All camber link mounting positions use vertical ballstuds that can be shimmed for precise roll center height adjustments.

Longer links will produce less camber gain, stiffening that particular end of the car in roll. These are particularly effective on large tracks with big sweeping corners. Shorter links will give more camber gain, softening that end of the car in roll. This will make the car more aggressive, and is a good setting for smaller indoor tracks with high grip levels.

The angle of the camber link will make fine adjustments to the roll center height. Typically the camber link will be no more than parallel to the suspension arm with the inboard side of the link lower than the outboard side. As the inboard side of the camber link is moved down, the roll center goes up, stiffening that end of the car. Camber link angle is a good adjustment to help fine tune the balance of the car to the track by setting the front and rear at slightly different angles.

Arm Mount Position:

The TC6.2's arm mount system allows for maximum adjustability for all track and racing conditions. Independent inner and outer arm mounts with interchangeable inserts provide multiple pin configurations... flat, or with angle, to give a host of kickup/tow and pin width options.

Use the TC6.2's included arm mount inserts to adjust pin width and angle. The arm mount inserts are indicated one, two, and three with the corresponding amount of dots on their exposed face. Each insert will index the hinge pin by 1/2 degree (or 0.43mm). Standard pin angle is achieved when using the same insert in both the inner and outer mounts. Rear hinge pin angle is 3° when using the same insert in both inner and outer mounts.

The chart to the right shows the pin angle change for the right rear pin when using a 1 dot insert in the inner arm mount.

Pin width can also be adjusted by changing the inserts in the inner and outer mounts by an equal amount. The standard pin width for the TC6.2 uses 1 dot inserts at all corners, and is best suited for rubber tire racing.

The TC6.2's independent inner and outer arm mount system also allows for roll center height adjustments as well as options for anti-dive/kick-up and anti-squat/pro-squat hinge pin angles. Precise adjustments can be made by changing the shim thickness between the arm mounts and chassis.

The standard roll center height uses 0.5mm shims on all mounts. This produces a relatively low roll center with more chassis roll on the corners... typically good for lower grip conditions such as rubber tires on asphalt. If the grip level is high, try raising the roll center by using thicker shims between the mounts and chassis.

Anti-dive/kick-up and anti-squat/pro-squat angles can be adjusted by varying the amount of shims under the inner and outer mounts. A 0.5mm difference will produce an angle of about 1/2 degree. The following sections briefly describe front and rear pin angles and their effect on the track.

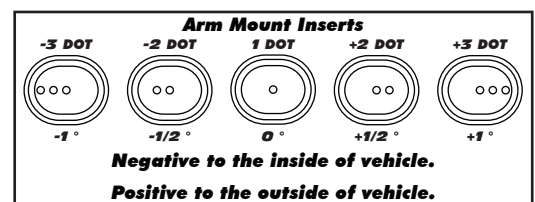
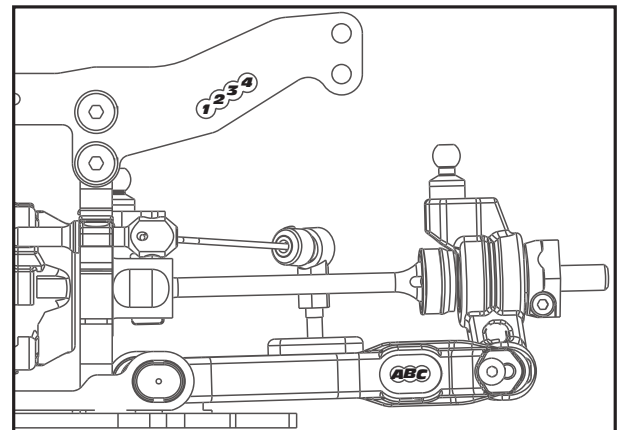

:: Tuning Tips

Anti-Dive (front):

Anti-dive is a front arm angle where the rear mount is higher than the front mount. Adding anti-dive reduces weight transfer to the front on deceleration entering corners. It also reduces caster at the wheel.

Kick-Up (front):

Kick-up describes the angle of the front suspension arm, where the front mount is higher than the rear mount. Increasing kick-up will give more entry steering, as well as increasing caster at the wheel.

Anti-Squat (rear):

Anti-Squat describes a rear arm angle where the front mount is higher than the rear mount. Increasing anti-squat will make the rear suspension stiffer. It tends to give the car more entry steering and reduce rearward weight transfer on power.

Pro-Squat (rear):

Pro-squat is a rear arm angle where the rear mount is higher than the front mount. Running Pro-Squat will increase rearward weight transfer on power.

Anti-Roll Bar:

Anti-roll bars are only effective during roll (when the chassis leans from side to side when cornering). Because of this they isolate a change in the suspensions spring rate in the corners only, and can be a very useful tuning option.

Anti-roll bars stiffen the spring rate of the suspension during roll movements when cornering. The larger the roll bar wire, the stiffer the spring rate will be in roll. The chart on the right shows the available anti-roll bar sizes (as well as their corresponding colors) from the softest on the top, to the stiffest on the bottom.

Anti Roll Bar Color/Size Chart	
Green	0.8mm
White	0.9mm
Blue	1.0mm
Yellow	1.1mm
Red	1.2mm

The standard setup, using yellow front anti-roll bars (1.1mm) and white rear anti-roll bars (0.9mm), is a balanced starting point. Changing the size of the front or rear anti-roll bars can help to make the chassis more consistent through the corner. Decreasing the size of the front anti-roll bars will help to increase mid-corner steering, but will tend to be less stable in sweepers. This is a typical setup for smaller tracks with tighter turns. Increasing the size of the front anti-roll bars will give more stability in the sweepers, and is better for larger tracks with high speed corners. Increasing the size of the rear anti-roll bars will help add stability into and through the corner in high traction conditions, but can make the car inconsistent in low traction, or bumpy, surfaces.

Belt Tension:

When altering the differential height, you will need to adjust the tension of the belt. The following chart shows suggested starting positions.

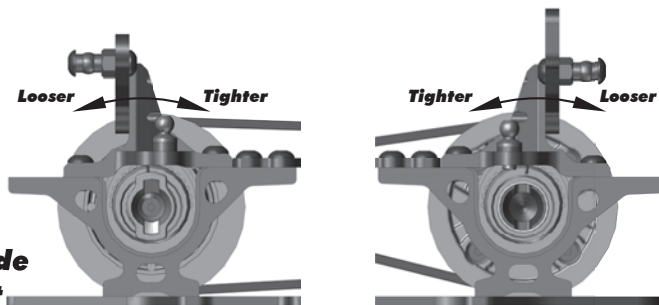

Cam Position

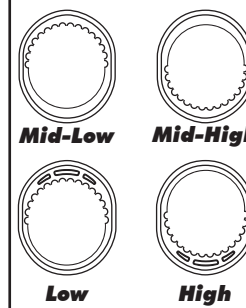

Belt Tension Number

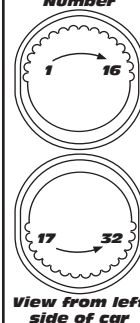

Front	Height	Pos.
	High	31
	Mid-High	28
	Mid	8
Low	5	
Rear	Height	Pos.
	High	18
	Mid-High	20
	Mid	7
Low	9	

Note! Charts show left side cam positions from the left side of the car. Match right side cam position to left side cam position.

Motor Gearing:

The gear charts on the following page show final drive ratio numbers for the TC6.2. Refer to motor manufacturer's suggested gear ratio for starting point. You may need to adjust the gearing according to your track size.

The following formula's can also be helpful in determining final drive ratios and pinion size.

$$TC6 \text{ Internal Ratio} = 2.0$$

$$\text{Final Drive Ratio} = \frac{\text{\# of Teeth Spur} \times \text{(Internal Ratio)}}{\text{\# of Teeth on Pinion}}$$

$$\text{\# of Teeth on Pinion} = \frac{\text{\# of Teeth on Spur} \times \text{(Internal Ratio)}}{\text{Final Drive Ratio}}$$

:: Gear Chart 48 Pitch



Blank spaces in the gear charts designates a gear ratio that will not fit in the vehicle. Gear fitment will also depend on the motor brand.

		Spur Gear Teeth (48 Pitch)											Advanced Timing Stock Brushless and Modified Brushless
Pinion teeth (48 Pitch)		77	78	79	80	81	82	83	84	85	86	87	
	15	--	--	--	--	--	--	--	--	--	--	--	11.60
	16	--	--	--	--	--	--	--	--	--	10.75	10.88	
	17	--	--	--	--	--	--	--	--	10.00	10.12	10.24	
	18	--	--	--	--	--	--	--	9.33	9.44	9.56	9.67	
	19	--	--	--	--	--	--	8.74	8.84	8.95	9.05	9.16	
	20	--	--	--	--	--	8.20	8.30	8.40	8.50	8.60	8.70	
	21	--	--	--	--	7.71	7.81	7.90	8.00	8.10	8.19	8.29	
	22	--	--	--	7.27	7.36	7.45	7.55	7.64	7.73	7.82	7.91	
	23	--	--	6.87	6.96	7.04	7.13	7.22	7.30	7.39	7.48	7.57	
	24	--	6.50	6.58	6.67	6.75	6.83	6.92	7.00	7.08	7.17	7.25	
	25	6.16	6.24	6.32	6.40	6.48	6.56	6.64	6.72	6.80	6.88	6.96	
26	5.92	6.00	6.08	6.15	6.23	6.31	6.38	6.46	6.54	6.62	6.69		
27	5.70	5.78	5.85	5.93	6.00	6.07	6.15	6.22	6.30	6.37	6.44		
28	5.50	5.57	5.64	5.71	5.79	5.86	5.93	6.00	6.07	6.14	6.21		

		Spur Gear Teeth (48 Pitch)											Non-Timing Stock Brushless
Pinion teeth (48 Pitch)		66	67	68	69	70	71	72	73	74	75	76	
	36	3.67	3.72	3.78	3.83	3.89	3.94	4.00	4.06	4.11	4.17	4.22	
	37	3.57	3.62	3.68	3.73	3.78	3.84	3.89	3.95	4.00	4.05	4.11	
	38	3.47	3.53	3.58	3.63	3.68	3.74	3.79	3.84	3.89	3.95	4.00	
	39	3.38	3.44	3.49	3.54	3.59	3.64	3.69	3.74	3.79	3.85	3.90	
	40	3.30	3.35	3.40	3.45	3.50	3.55	3.60	3.65	3.70	3.75	--	
	41	3.22	3.27	3.32	3.37	3.41	3.46	3.51	3.56	3.61	--	--	
	42	3.14	3.19	3.24	3.29	3.33	3.38	3.43	3.48	--	--	--	
	43	3.07	3.12	3.16	3.21	3.26	3.30	3.35	--	--	--	--	
	44	3.00	3.05	3.09	3.14	3.18	3.23	--	--	--	--	--	

:: Gear Chart 64 Pitch

		Spur Gear Teeth (64 Pitch)														Advanced Timing Stock Brushless and Modified Brushless
Pinion teeth (64 Pitch)		102	103	104	105	106	107	108	109	110	111	112	113	114	115	
	20	--	--	--	--	--	--	--	--	--	--	--	--	--	--	11.50
	21	--	--	--	--	--	--	--	--	--	--	--	--	--	10.86	10.95
	22	--	--	--	--	--	--	--	--	--	--	--	10.27	10.36	10.45	
	23	--	--	--	--	--	--	--	--	--	--	--	9.83	9.91	10.00	
	24	--	--	--	--	--	--	--	--	--	--	9.33	9.42	9.50	9.58	
	25	--	--	--	--	--	--	--	--	--	8.88	8.96	9.04	9.12	9.20	
	26	--	--	--	--	--	--	--	8.46	8.54	8.62	8.69	8.77	8.85		
	27	--	--	--	--	--	--	8.07	8.15	8.22	8.30	8.37	8.44	8.52		
	28	--	--	--	--	--	7.71	7.79	7.86	7.93	8.00	8.07	8.14	8.21		
	29	--	--	--	--	7.38	7.45	7.52	7.59	7.66	7.72	7.79	7.86	7.93		
	30	--	--	--	7.07	7.13	7.20	7.27	7.33	7.40	7.47	7.53	7.60	7.67		
	31	--	--	6.77	6.84	6.90	6.97	7.03	7.10	7.16	7.23	7.29	7.35	7.42		
	32	--	6.50	6.56	6.63	6.69	6.75	6.81	6.88	6.94	7.00	7.06	7.13	7.19		
	33	--	6.24	6.30	6.36	6.42	6.48	6.55	6.61	6.67	6.73	6.79	6.85	6.91	6.97	
	34	6.00	6.06	6.12	6.18	6.24	6.29	6.35	6.41	6.47	6.53	6.59	6.65	6.71	6.76	
	35	5.83	5.89	5.94	6.00	6.06	6.11	6.17	6.23	6.29	6.34	6.40	6.46	6.51	6.57	
	36	5.67	5.72	5.78	5.83	5.89	5.94	6.00	6.06	6.11	6.17	6.22	6.28	6.33	6.39	
	37	5.51	5.57	5.62	5.68	5.73	5.78	5.84	5.89	5.95	6.00	6.05	6.11	6.16	6.22	
38	5.37	5.42	5.47	5.53	5.58	5.63	5.68	5.74	5.79	5.84	5.89	5.95	6.00	6.05		
39	5.23	5.28	5.33	5.38	5.44	5.49	5.54	5.59	5.64	5.69	5.74	5.79	5.85	5.90		

		Spur Gear Teeth (64 Pitch)														Non-Timing Stock Brushless
Pinion teeth (64 Pitch)		88	89	90	91	92	93	94	95	96	97	98	99	100	101	
	47	3.74	3.79	3.83	3.87	3.91	3.96	4.00	4.04	4.09	4.13	4.17	4.21	4.26	4.30	
	48	3.67	3.71	3.75	3.79	3.83	3.88	3.92	3.96	4.00	4.04	4.08	4.13	4.17	4.21	
	49	3.59	3.63	3.67	3.71	3.76	3.80	3.84	3.88	3.92	3.96	4.00	4.04	4.08	4.12	
	50	3.52	3.56	3.60	3.64	3.68	3.72	3.76	3.80	3.84	3.88	3.92	3.96	4.00	4.04	
	51	3.45	3.49	3.53	3.57	3.61	3.65	3.69	3.73	3.76	3.80	3.84	3.88	3.92	3.96	
	52	3.38	3.42	3.46	3.50	3.54	3.58	3.62	3.65	3.69	3.73	3.77	3.81	3.85	3.88	
	53	3.32	3.36	3.40	3.43	3.47	3.51	3.55	3.58	3.62	3.66	3.70	3.74	3.77	3.81	
	54	3.26	3.30	3.33	3.37	3.41	3.44	3.48	3.52	3.56	3.59	3.63	3.67	3.70	--	
	55	3.20	3.24	3.27	3.31	3.35	3.38	3.42	3.45	3.49	3.53	3.56	3.60	--	--	
	56	3.14	3.18	3.21	3.25	3.29	3.32	3.36	3.39	3.43	3.46	3.50	--	--	--	
	57	3.09	3.12	3.16	3.19	3.23	3.26	3.30	3.33	3.37	3.40	--	--	--	--	
58	3.03	3.07	3.10	3.14	3.17	3.21	3.24	3.28	3.31	--	--	--	--	--		

:: Shocks

5407	Red O-Rings	8
6465	Shock Piston, PTFE	12
6475	Preload Spacers, Collars, Cups	1
31305	Turnbuckle Eyelet	14
31323	VCS3 Shock Kit	1
31324	VCS3 Shock Rebuild	1
31325	VCS3 Shock Body	2
31326	VCS3 Shock Collar	2
31327	VCS3 Shock Bottom Cap	2
31328	VCS3 Aluminum Cap Retainer	2
31329	VCS3 Shock Cap	4
31330	VCS3 Shock Shaft	2
31510	M2x4mm BHCS	6

:: Springs

3941	TC Spring, Green, 12.0lbs	Pr.
3942	TC Spring, Silver, 14.5lbs (Kit)	Pr.
3943	TC Spring, Blue, 17.0lbs	Pr.
3944	TC Spring, Gold, 19.5lbs	Pr.
3945	TC Spring, Red, 22.0lbs	Pr.
3946	TC Spring, Copper, 25.0lbs	Pr.
3952	TC Spring, Purple, 30.0lbs	Pr.
3953	TC Spring, Yellow, 35.0lbs	Pr.
3954	TC Spring, White, 40.0lbs	Pr.
3988	TC Spring Set, 1 pr. each	1



:: Shock Fluid

5420	10 Weight Silicone Shock Fluid	2oz.
5421	20 Weight Silicone Shock Fluid	2oz.
5422	30 Weight Silicone Shock Fluid	2oz.
5423	40 Weight Silicone Shock Fluid	2oz.
5424	22.5 Weight Silicone Shock Fluid	2oz.
5425	80 Weight Silicone Shock Fluid	2oz.
5426	27.5 Weight Silicone Shock Fluid	2oz.
5427	15 Weight Silicone Shock Fluid	2oz.
5428	25 Weight Silicone Shock Fluid	2oz.
5429	35 Weight Silicone Shock Fluid	2oz.
5430	45 Weight Silicone Shock Fluid	2oz.
5431	55 Weight Silicone Shock Fluid	2oz.
5432	32.5 Weight Silicone Shock Fluid	2oz.
5433	37.5 Weight Silicone Shock Fluid	2oz.
5434	42.5 Weight Silicone Shock Fluid	2oz.
5435	50 Weight Silicone Shock Fluid	2oz.
5436	60 Weight Silicone Shock Fluid	2oz.
5437	70 Weight Silicone Shock Fluid	2oz.
5438	47.5 Weight Silicone Shock Fluid	2oz.



:: CVA's

31237	CVA Pin Retaining Clip	2
31238	CVA Bone Blade	8
31366	TC6.1 CVA Kit	1
31367	TC6.1 CVA Rebuild Kit	1
31368	TC6.1 CVA Bone	Pr.
31369	TC6.1 Stub Axle	Pr.
31500	M3x2.5mm Set Screw	6

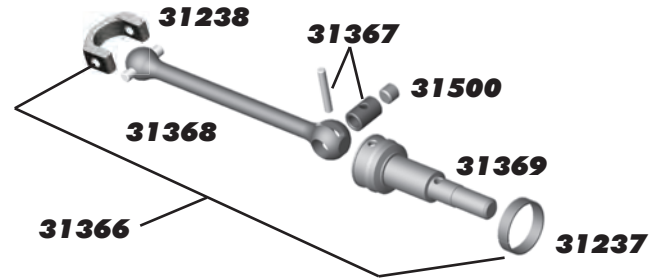

:: Anti-Roll Bars

8828	Anti-Roll Bar Cups, Set	1
31058	Anti-Roll Bar Ballstud, blue aluminum	2
31364	TC6.1 Anti-Roll Bar Wire, Set	1
31365	TC6.1 Anti-Roll Bar Mounts	4
31500	M3x2.5mm Set Screw	6
31511	M2x5mm SHCS	6
31627	TC6.2 Anti-Roll Bar Tube	1
31628	TC6.2 Anti-Roll Bar Kit	1

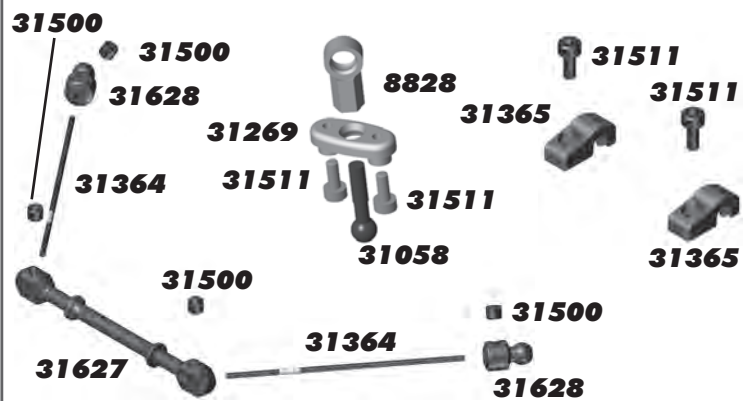

:: Turnbuckles

1402	FT Blue Titanium Turnbuckles 1.375"	Pr.
1405	FT Blue Titanium Turnbuckle 1.875"	Pr.
1418	FT Blue Titanium Turnbuckle 0.825"	Pr.
31305	Turnbuckle Eyelet	14

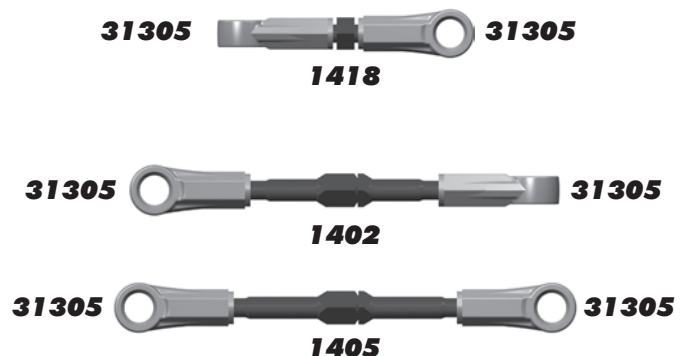

:: Front Spool

31162	Axle Shim Kit	1
31175	Oneway/Spool Pulley	1
31339	TC6 Spool Kit	1
31341	TC6 Spool Outdrives	4
31342	TC6 Spool Hub	1
31350	M2.5x10mm FHCS	6
31401	10 x 15mm Bearing	2
31510	M2x4mm BHCS	6
31615	TC6.2 Diff Bearing Cam Set	1

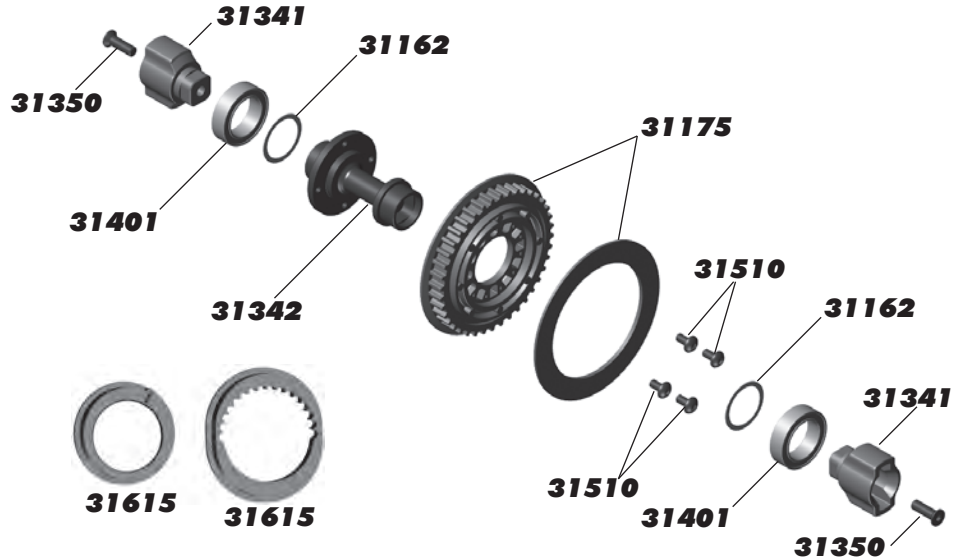

:: Rear Gear Differential

4675	M2.5 X .45 X 6 FHCS	6
31162	Axle Shim Kit	1
31344	TC6 Gear Diff	1
31345	TC6 Gear Diff Rebuild	1
31346	TC6 Gear Diff Outdrives	2
31347	TC6 Gear Diff Case, O-Ring, Pulley	1
31348	TC6 Gear Diff Pins & Shims	1
31349	TC6 Gear Diff Seals	1
31401	10 x 15mm Bearing	2
31615	TC6.2 Diff Bearing Cam Set	1

See page 30 for shock fluids for use with the TC gear differential.

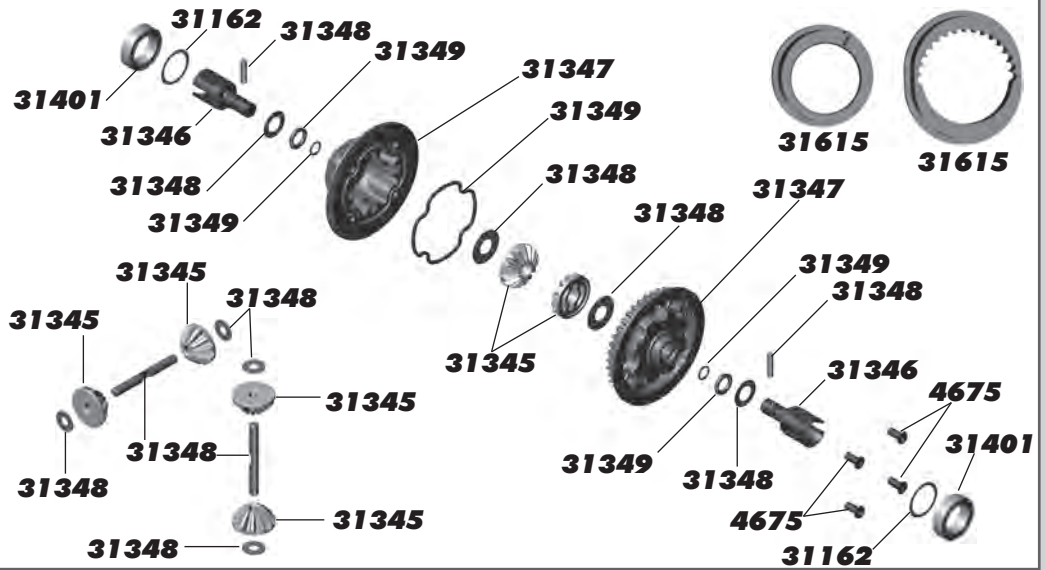

:: Spur Gear Assembly

31160	3mm E-Clip	6
31162	Axle Shim Kit	1
31314	TC6 Spur Gear Hub	1
31315	TC6 Spur Gear Shaft	1
31319	TC6 Spur Clamping Ring	1
31320	TC6 Spur Pulley (20T)	2
31331	4x8x3mm Flanged Bearing	2
31333	TC6 Spur Gear (87T/48P)	1
31521	M2.5x0.5x8mm BHCS	6
31530	M3x0.5x5mm BHCS	6

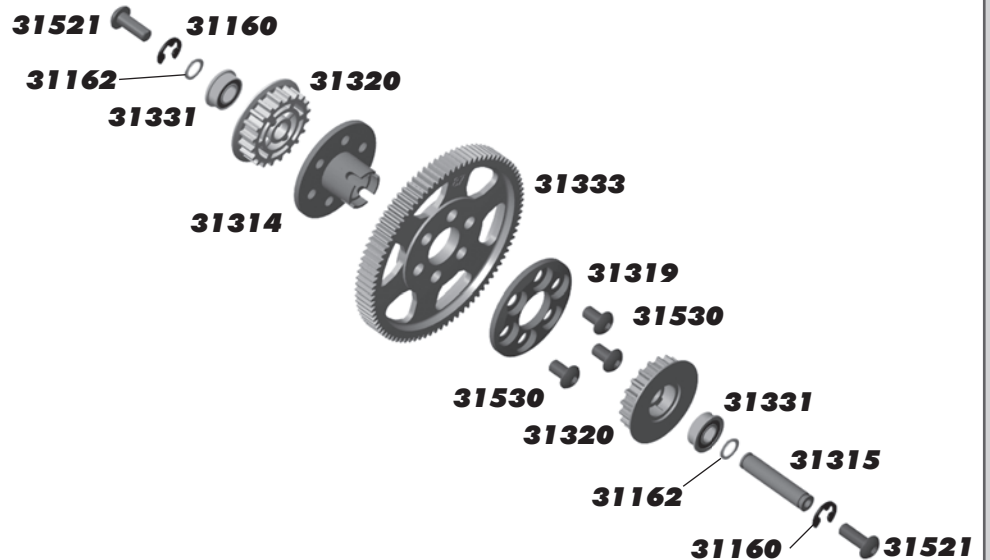

:: Steering Bellcrank and Servo Mounts

7336	Steering Servo Mount Kit	1
7337	.250" x.125" x.015" Washer	4
25211	M3x10mm BHCS	20
31283	5mm Ballstud, long	6
31286	Aluminum Ballstud Washers, Set	1
31374	FT TiN 3.25mm Ballstud, short	2
31403	4x7mm Bearing	2
31530	M3x5mm BHCS	6
31532	M3x8mm BHCS	6
31540	M3x5mm FHCS	6
31550	FT M3 Locknut, blue aluminum	6
31608	TC6.2 Servo Mount Brace	1
31609	TC6.2 Steering Bellcrank Post Set	1
31610	TC6.2 Steering Bellcrank	1
31611	TC6.2 Steering Rack Set	1
31622	TC6.2 Servo Mount Set	1
89007	Steering Servo Horn & Ring	1

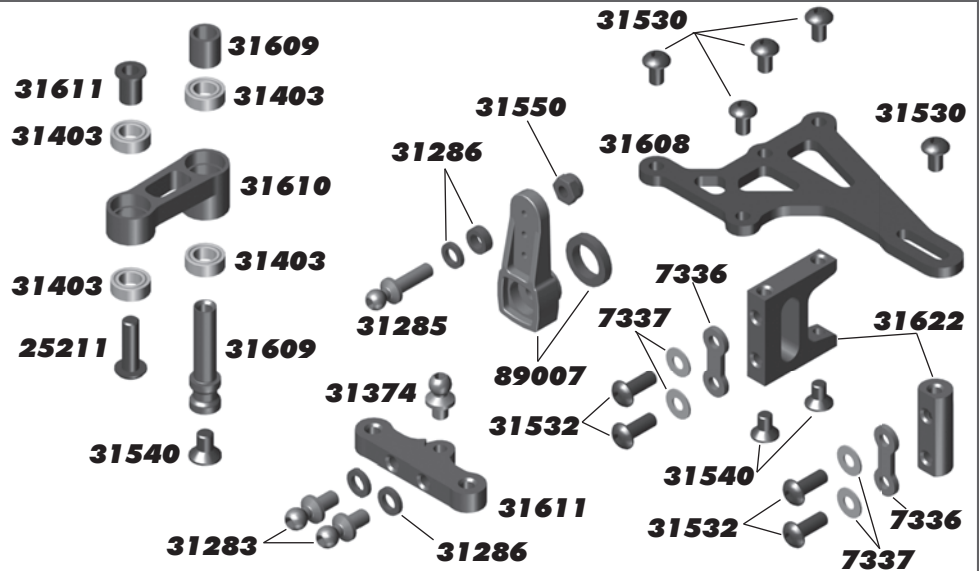

:: Front Bumper

1736	FT Body Clips, short	6
3897	Pivoting Body Mounts, Set	1
4673	M2.5x4mm BHCS	6
25201	M3x8mm FHCS	20
25203	M3x12mm FHCS	20
31623	TC6.2 Bumper Set	1
31624	TC6.2 Foam Bumper	1
31625	TC6.2 Body Post Set	1

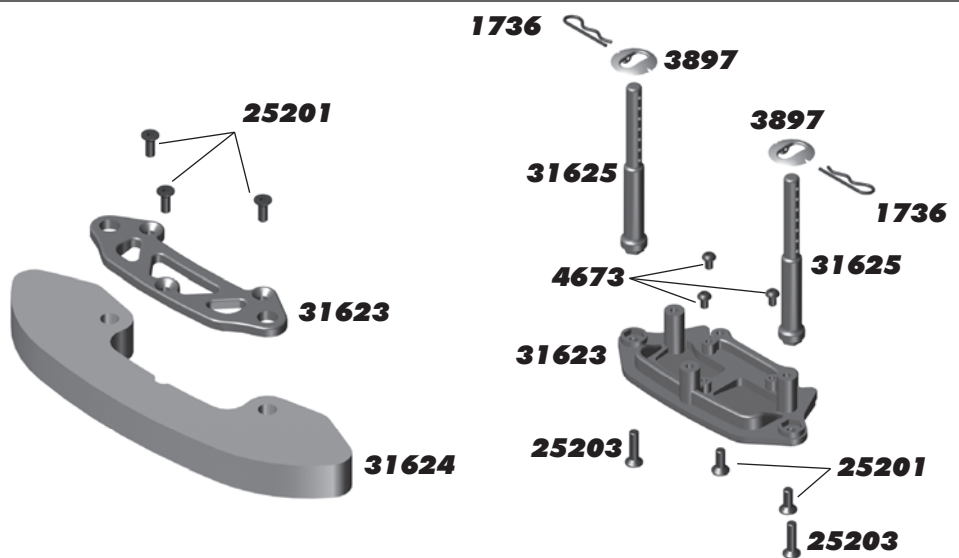

:: Front and Rear Shock Towers

1736	FT Body Clips, short	6
3897	Pivoting Body Mounts, Set	1
31250	Shock Bushing	4
31280	5mm Ballstud, short	6
31286	Aluminum Ballstud Washers, Set	1
31530	M3x5mm BHCS	6
31531	M3x6mm BHCS	6
31532	M3x8mm BHCS	6
31541	M3x6mm FHCS	6
31604	TC6.2 Front Shock Tower	1
31605	TC6.2 Rear Shock Tower	1
31613	TC6.2 Bearing Cap (A)	1
31614	TC6.2 Bearing Cap (B)	1
31625	TC6.2 Body Post Set	1

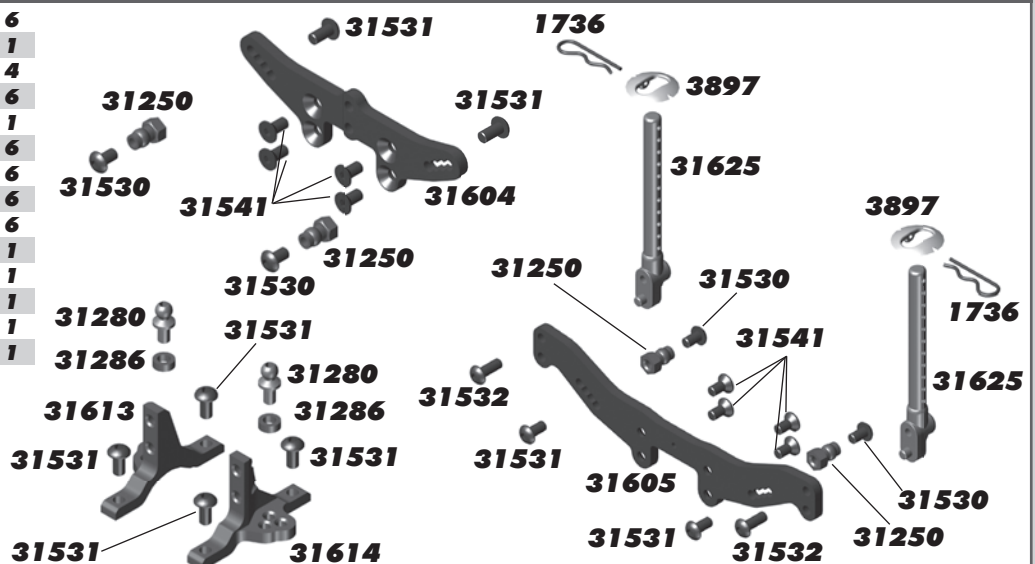

:: Front Bulkhead

25227	M4x8mm Setscrew	20
25237	5x10mm Bearing	2
31112	1/16" x 5/16" Dowel Pins	8
31162	Axle Shim Kit	1
31200	Wheelbase Shim Set	1
31214	Caster Block Bushing	Pr.
31221	Inner Hinge Pin Set	1
31222	Outer Hinge Pin Set	1
31234	Clamping Wheel Hex	4
31280	5mm Ballstud, short	6
31284	8mm Ballstud, long	6
31356	TC6.1 Front Arms	Pr.
31358	TC6.1 Caster Blocks	Pr.
31360	TC6.1 Steering Blocks	Pr.
31370	TC6.1 Axle Crush Tubes	4
31510	M2x4mm BHCS	6
31511	M2x5mm SHCS	6
31532	M3x8mm BHCS	6
31540	M3x5mm FHCS	6
31612	TC6.2 Bulkhead	1
31621	TC6.2 Inner Hinge Pin Ball Set	1
91148	M4 Locknut, with flange and knurl	8

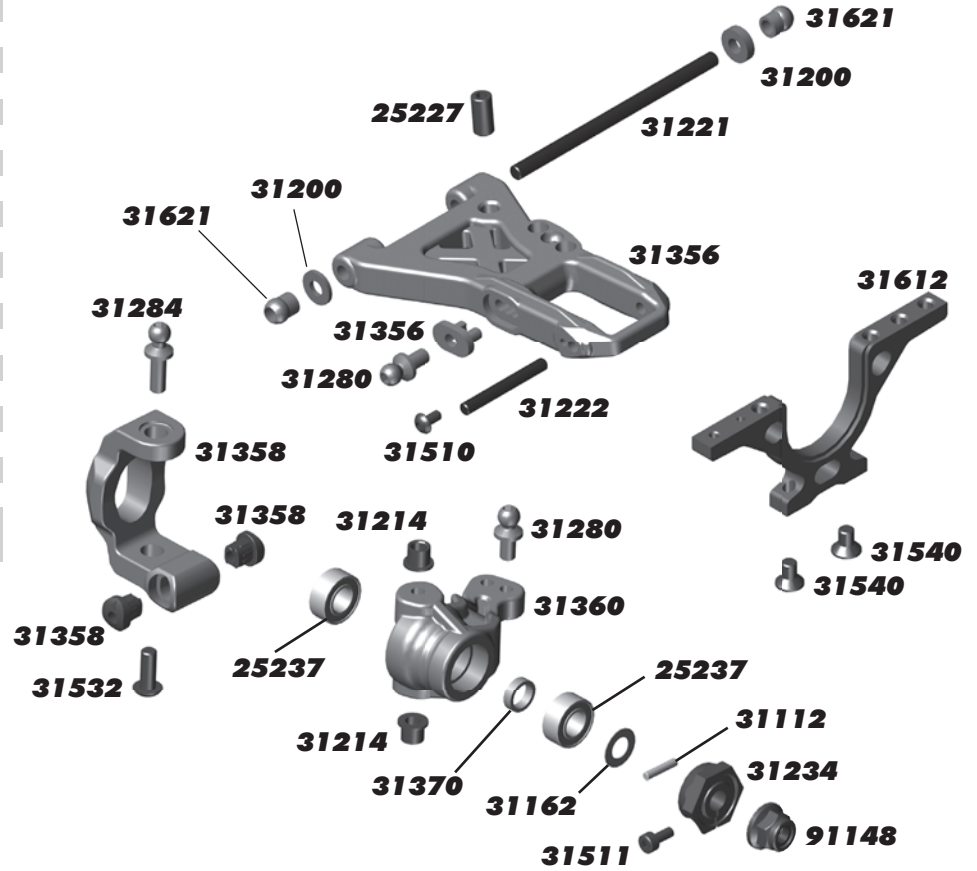

:: Rear Bulkhead

25227	M4x8mm Setscrew	20
25237	5x10mm Bearing	2
31112	1/16" x 5/16" Dowel Pins	8
31162	Axle Shim Kit	1
31200	Wheelbase Shim Set	1
31221	Inner Hinge Pin Set	1
31222	Outer Hinge Pin Set	1
31234	Clamping Wheel Hex	4
31283	5mm Ballstud, long	6
31284	8mm Ballstud, long	6
31286	Aluminum Ballstud Washers, Set	1
31357	TC6.1 Rear Arms	Pr.
31359	TC6.1 Rear Hub Carrier	Pr.
31370	TC6.1 Axle Crush Tubes	4
31510	M2x4mm BHCS	6
31511	M2x5mm SHCS	6
31540	M3x5mm FHCS	6
31612	TC6.2 Bulkhead	1
31621	TC6.2 Inner Hinge Pin Ball Set	1
91148	M4 Locknut, with flange and knurl	8

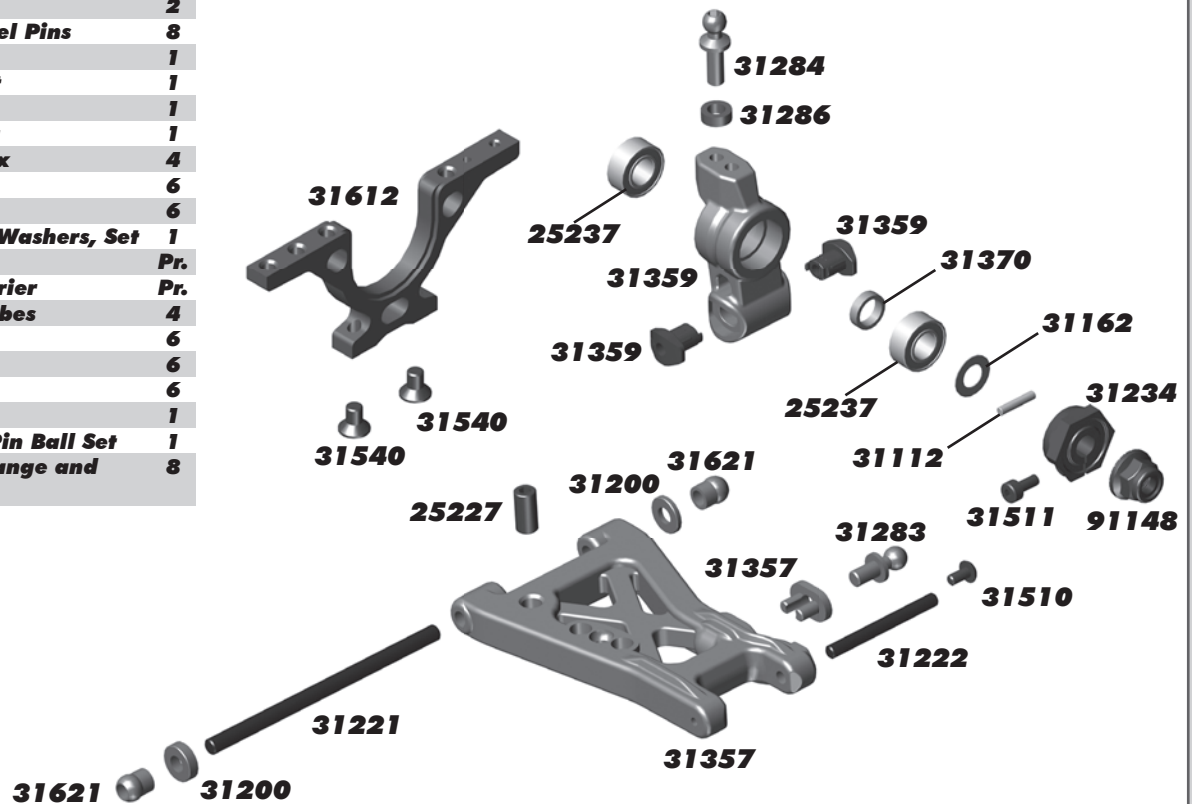

:: Motor Mount / Battery Mount

31286	Aluminum Ballstud Washers, Set	1
31532	M3x8mm BHCS	6
31540	M3x5mm FHCS	6
31541	M3x6mm FHCS	6
31616	TC6.2 Spur Gear Bulkhead	1
31617	TC6.2 Motor Mount Set	1
31626	TC6.2 LiPo Brace Set	1

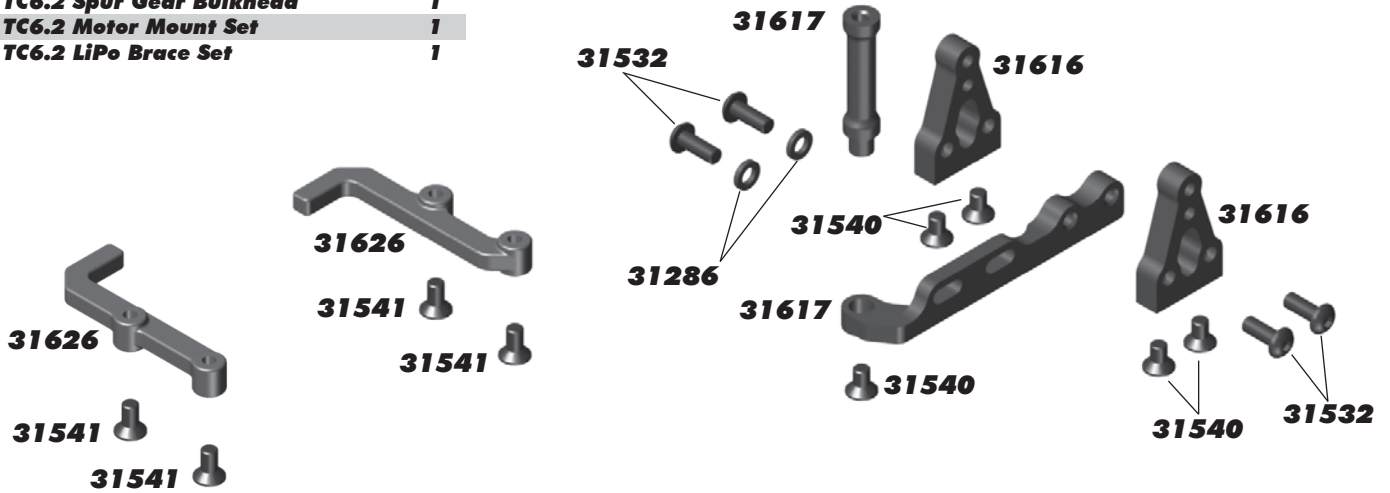

:: Chassis / Top Plate / Belts / Antenna / Arm Mounts

4617	Front Bulkhead Shim Set	1
6338	Antenna Tube 12", black	1
31187	Front Belt	1
31188	Rear Belt	1
31500	M3x2.5mm Set Screw	6
31530	M3x5mm BHCS	6
31540	M3x5mm FHCS	6
31541	M3x6mm FHCS	6
31600	TC6.2 Chassis	1
31601	TC6.2 Top Plate	1
31618	TC6.2 Outer Arm Mount	1
31619	TC6.2 Inner Arm Mount	1
31620	TC6.2 Arm Mount Insert Set	1
31626	TC6.2 LiPo Brace / Antenna Mount Set	1

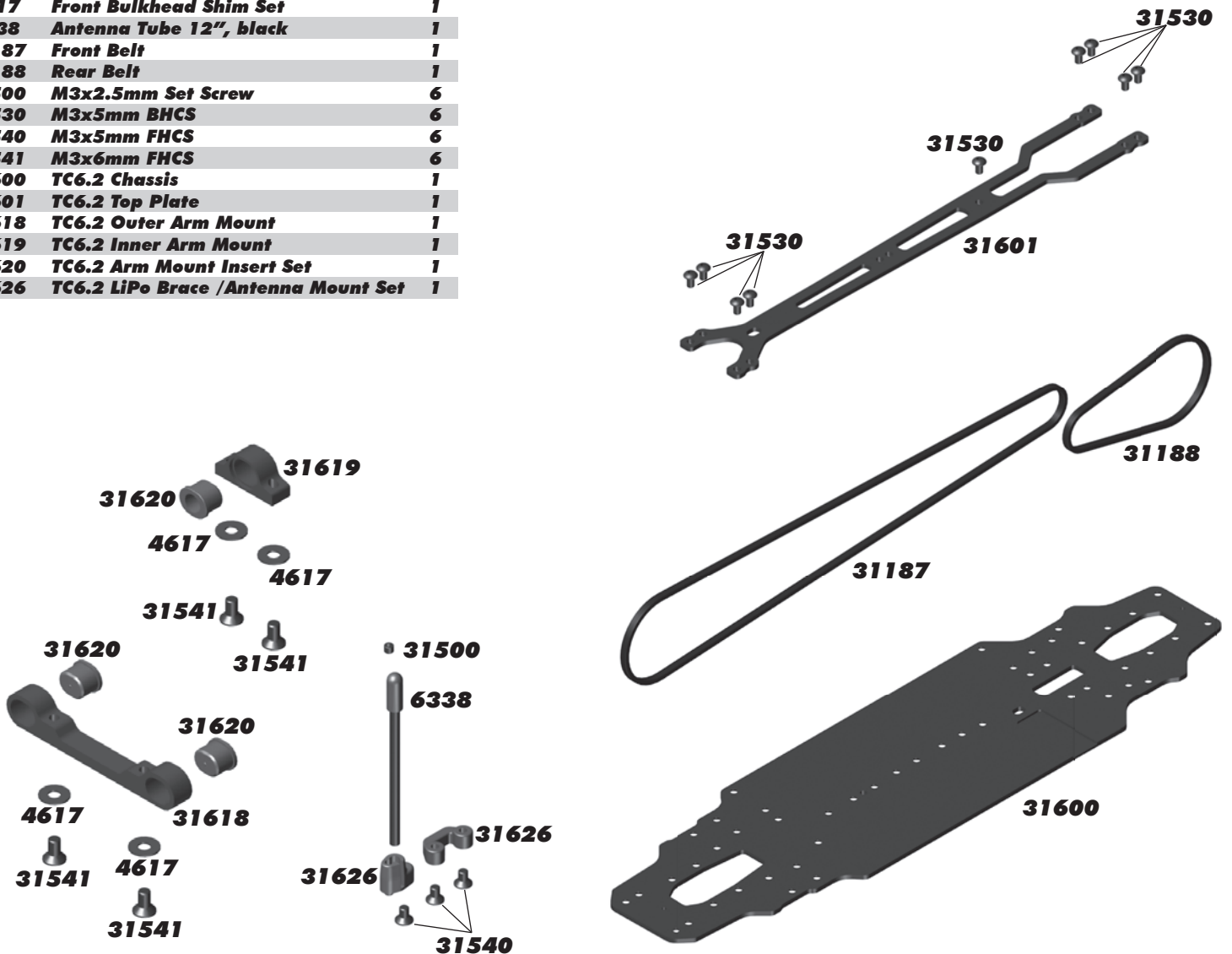

:: Pinions / Spur Gears

8253	16T 48P Pinion Gear	1	3921	69T 48P Spur Gear	1
8254	17T 48P Pinion Gear	1	3922	72T 48P Spur Gear	1
8255	18T 48P Pinion Gear	1	3923	75T 48P Spur Gear	1
8256	19T 48P Pinion Gear	1	3924	66T 48P Spur Gear	1
8257	20T 48P Pinion Gear	1	3994	73T 48P Spur Gear	1
8258	21T 48P Pinion Gear	1	4462	100T 64P Spur Gear	1
8259	22T 48P Pinion Gear	1	4615	96T 64P Spur Gear	1
8260	23T 48P Pinion Gear	1	31332	80T 48P Spur Gear	1
8261	24T 48P Pinion Gear	1	31333	87T 48P Spur Gear	1
8263	26T 48P Pinion Gear	1	31334	106T 64P Spur Gear	1
8264	27T 48P Pinion Gear	1	31335	115T 64P Spur Gear	1
8265	28T 48P Pinion Gear	1			
8266	29T 48P Pinion Gear	1			
8267	30T 48P Pinion Gear	1			
8268	31T 48P Pinion Gear	1			
8269	32T 48P Pinion Gear	1			
8270	33T 48P Pinion Gear	1			
8271	34T 48P Pinion Gear	1			
8272	35T 48P Pinion Gear	1			

:: Factory Team and Option Parts

1401	FT Blue Titanium Turnbuckle 1.300"	2			
1404	FT Blue Titanium Turnbuckle 1.775"	2			
1734	FT Blue Body Clip, 4 long, 6 short	10			
1735	FT Blue Body Clip, long	4			
1736	FT Blue Body Clip, short	6			
3927	Radial Heatsink, narrow	1			
3928	Radial Heatsink, wide	1			
3991	TC Aero Dish Wheel 24mm	4			
4617	12R5 Front Bulkhead Shims (0.5, 1.0, 2.0)mm 4 ea	12			
6463	1:10 Blank Shock Pistons	8			
25391	FT 4mm Locknuts, blue	10			
31280	5mm Ballstud, short	6			
31281	8mm Ballstud, short	6			
31282	10mm Ballstud, short	6			
31283	5mm Ballstud, long	6			
31284	8mm Ballstud, long	6			
31285	10mm Ballstud, long	6			
31286	Aluminum Ballstud Washer, Set	1			
31288	Ti Nitride Ballstuds 5mm, short	2			
31289	Ti Nitride Ballstuds 8mm, short	2			
31290	Ti Nitride Ballstuds 10mm, short	2			
31291	Ti Nitride Ballstuds 5mm, long	2			
31292	Ti Nitride Ballstuds 8mm, long	2			
31293	Ti Nitride Ballstuds 10mm, long	2			
31296	TC6 Ballast Weight	1			
31339	TC6 Spool Kit	1			
31344	TC6 Gear Differential Kit	1			
31441	10-Spoke Wheel, black	2			
31442	5-Spoke Wheel, black	2			
31443	5-Spoke Wheel, white	2			
31550	M3 Aluminum Lock Nut, blue	6			
31551	M4 Aluminum Flange Lock Nut, blue	6			
31629	TC6.2 Arm Mount Shims (outer)	4ea.			
31630	TC6.2 Arm Mount Shims (inner)	2ea.			
31632	TC6.2 DCV Kit	1			
31633	TC6.2 DCV Rebuild Kit	1			
31634	TC6.2 DCV Stub Axle	1			
31635	TC6.2 DCV Bone	1			
31636	TC6.2 DCV Coupler Tube	1			
31637	TC6.2 Gear Diff Outdrive, Steel	1			
31638	TC6.2 Spool Outdrive, Steel	1			
31639	TC6.2 Belt Tensioner Kit	1			
31640	TC6.2 Fan Mount Set	1			
31641	TC6.2 30mm Cooling Fan	1			

:: Lubes & Adhesives

1105	FT Green Slime Shock Lube	1
1596	FT Locking Adhesive	1
1597	FT Tire Adhesive, medium	1
6588	Black Grease - 4cc	1
6591	S.Diff Lube - 4cc	1
6636	Silicone Grease - 4cc	1
6727	Servo Tape	2
9787	Chassis Protective Sheet	1

**:: Decals**

716	Reedy 2009 Sticker Set	1
3816	American Bumper Sticker	1
3820	AE Logo Decal Sheet	1
3834	AE Blue Embossed Logo Sticker	2
31642	TC6.2 Decal Sheet	1

:: XP Electronics

29138	XP SC500 Brushless ESC	1
29139	XP SC900-BL ESC	1
29141	XP SC450-BL Brushless ESC	1
29142	XP ESC Fan Option	1
29143	XP SC700-BL Brushless ESC	1
29144	XP SC1200 Brushless ESC	1
29166	XP DS1313 Digital Servo	1
29167	XP DS1015 Digital Servo	1
29168	XP DS1510MG Servo	1
29209	Gear Set, DS1313	1
29210	Gear Set, DS1015	1
29211	Servo Case, DS1313/DS1015	1
29212	Accessory Pack, DS1313/DS1015	1
29214	TRS 403-SSi Receiver	1
29215	XP2G Radio System	1
29216	XP3G Radio System	1
29250	XP DS1505 Servo	1
29251	XP DS1505MG Servo	1
29252	XP DS1505 Metal Gear Set	1
29253	XP DS1510 Metal Gear Set	1
29254	Receiver Antenna	1

:: Reedy Motors

228	Sonic 540 Mach 2 25.5 Comp. Brushless Motor	1
231	Sonic 540 Mach 2 21.5 Comp. Brushless Motor	1
232	Sonic 540 Mach 2 17.5 Comp. Brushless Motor	1
233	Sonic 540 Mach 2 13.5 Comp. Brushless Motor	1
234	Sonic 540 Mach 2 10.5 Comp. Brushless Motor	1
235	Sonic 540 Mach 2 9.5 Comp. Brushless Motor	1
236	Sonic 540 Mach 2 8.5 Comp. Brushless Motor	1
237	Sonic 540 Mach 2 8.0 Comp. Brushless Motor	1
238	Sonic 540 Mach 2 7.5 Comp. Brushless Motor	1
239	Sonic 540 Mach 2 7.0 Comp. Brushless Motor	1
240	Sonic 540 Mach 2 6.5 Comp. Brushless Motor	1
241	Sonic 540 Mach 2 6.0 Comp. Brushless Motor	1
242	Sonic 540 Mach 2 5.5 Comp. Brushless Motor	1
243	Sonic 540 Mach 2 5.0 Comp. Brushless Motor	1
244	Sonic 540 Mach 2 4.5 Comp. Brushless Motor	1
245	Sonic 540 Mach 2 4.0 Comp. Brushless Motor	1
246	Sonic 540 Mach 2 3.5 Comp. Brushless Motor	1
954	Sonic 540 Stock Rotor 12.3 x 24.2 (7.25)	1
955	Sonic 540 Stock Rotor 12.3 x 25.0 (7.25)	1
956	Sonic 540 Stock Rotor 12.5 x 25.0 (7.25)	1
957	Sonic 540 Modified Rotor 12.2 x 25.0 (5.0)	1
958	Sonic 540 Modified Rotor 12.5 x 25.0 (5.0)	1
987	Sonic 540 Modified Rotor 13.0 x 25.0 (5.0)	1

:: Reedy Batteries and Chargers

302	AA Alkaline 1.5V (4)	1
304	LiPo Pro TX/RX Battery 1600mAh 7.4V Flat	1
305	LiFe Pro TX/RX Battery 1300mAh 6.6V Flat	1
309	LiPo 65C 7000mAh 7.4V	1
313	LiPo 65C 7000mAh 7.4V (5mm)	1
602	LiPo 65C 4100mAh 7.4V Shorty	1
604	526-S AC/DC 2S-6S LiPo/LiFe Charger	1
632	LiPo TX Lightweight Battery 1350mAh 11.1V	1
637	LiPo TX Battery - M11X 2500mAh 7.4V	1
736	Wolfpack LiPo 5000mAh 7.4V 25C	1
738	Wolfpack LiPo 3800mAh 7.4V 25C Shorty	1
739	Wolfpack LiPo 5500mAh 7.4V 60C	1

:: Reedy Accessories

233S	Sonic 540/540 Mach 2 Stator 13.5	1
247	Sonic 540 Mach 2 Sensor w/bearing	1
248	Sonic 540 Mach 2 Steel Bearing Set	1
249	Sonic 540 Mach 2 Ceramic Bearing Set	1
250	Sonic 540 Mach 2 Insulator Set	1
605	Motor Cooling Fans (2)	1
607	Charge Harness 2S Standard Pack 4mm	1
654	4.0mm Bullet Plugs (2M, 2F)	1
655	4.0mm Bullet Plugs (2M, 10F)	1
656	4.0mm Bullet Plugs (10F)	1
657	4.0mm Bullet Plugs (100F)	1
658	4.0mm Bullet Plugs (10M)	1
659	4.0mm Bullet Plugs (30M)	1
669	5mm Bullet Connector	2
941S	Sonic 540/540 Mach 2 Stator 17.5	1
959	Sonic 540/550 Sensor w/Bearing	1
960	Sonic 540/550 Insulator Set (2 pcs.)	1
961	Sonic 540/550 Timing Cap w/Screws	1
962	Sonic 540/540 Mach 2 Case Screws (3 pcs.)	1
972	Sonic 540 Steel Bearing Set	1
973	Sonic 540 Ceramic Bearing Set	1
978	Flat Sensor Wire 70mm	1
979	Flat Sensor Wire 110mm	1
980	Flat Sensor Wire 150mm	1
981	Flat Sensor Wire 200mm	1
982	Flat Sensor Wire 270mm	1
992	Sonic 540 Rotor Spacers	1

:: RePlay Cameras

RP001	Replay XD1080 Complete Camera System	1
RP002	Replay XD720 Complete Camera System	1
RP021	Replay XD1080 Lens Bezel Kit	1
RP022	Replay XD1080 Clear Lens Cover	1
RP023	Replay XD1080 Lens Bezel & Rear Cap O-Ring	1
RP024	Replay XD Lens Bezel	1
RP029	Replay XD1080 HDMI to Mini-HDMI	1
RP030	Replay XD1080 Mini 8-pin USB Charge Data Cable	1
RP032	USB DC Car Charger 1A Stubby	1
RP033	USB DC Car Charger 500mAh	1
RP034	Micro SDHC USB Reader	1
RP036	3M VHB 4991 Mount Adhesive for SnapTray	1
RP038	3M VHB 5962 Mount Adhesive for SnapTray	1
RP041	Replay XD Suction Cup Arm Mini Clamp	1
RP042	Replay XD Suction Cup Short Arm Base	1
RP043	Replay XD Skateboard Mount	1
RP044	Replay XD VHB SnapTray, Convex	1
RP045	Replay XD VHB SnapTray, Flat	1
RP046	Au Plug for Universal DC Wall Charger	1
RP047	Eu Plug for Universal DC Wall Charger	1
RP048	Uk Plug for Universal DC Wall Charger	1
RP049	Universal USB DC Wall Charger 1A	1
RP054	Replay ReView Field Monitor	1

:: Qualifier Series Vehicles

7052	Pro Lite 4x4 RTR, 1/10 Scale (ready-to-run)	1
20111	Rival Mini Monster Truck 1/18 Scale (ready-to-run)	1
20119	APEX Mini Touring RTR	1
20510	RIVAL Electric Monster Truck RTR, 1/8 Scale (ready-to-run)	1
30112	APEX Touring V-Type, 1/10 Scale (ready-to-run)	1

:: 1/18 Kits and RTR's

20103	RC18B2 - RC18T2 Team Kit	1
20121	SC18 RTR Brushless (ready-to-run)	1

:: 1/12, 1/10 Kits and RTR's

4020	FT 12R5.2 Kit	1
6001	RC10 Classic Kit	1
7025	FT RC10T4.2 Kit	1
7029	SC10 Associated/RC10.com Truck RTR (ready-to-run)	1
7030	SC10 KMC Wheels Race Truck RTR (ready-to-run)	1
7038	FT SC10.2 Kit	1
7039	RC10T4.2 RS RTR 2.4GHz Brushless (ready-to-run)	1
7046	SC10 RS RTR, Lucas Oil (ready-to-run)	1
7049	SC10 RS RTR, Rockstar/Makita (ready-to-run)	1
7050	SC10 RS RTR, Hart and Huntington (ready-to-run)	1
7051	SC10 RS RTR, Lucas Slick Mist® Body	1
7054	SC10 RS RTR, Toyota Racing/TRD	1
7055	SC10 RS RTR, Monster Energy Toyota	1
7093	SC10GT RTR (ready-to-run)	1
8020	FT RC10R5 Kit	1
8022	FT RC10R5.1 Kit	1
9040	FT RC10B4.1 Worlds Kit	1
9041	FT RC10B4.2 Kit	1
9042	RC10B4.2 RS RTR 2.4GHz Brushless (ready-to-run)	1
9050	SC10B RS RTR (ready-to-run)	1
9062	FT B44.2 4WD Buggy Kit	1
30101	TC4 Club Racer 4WD Touring Car Race Roller	1
30109	FT TC6.2 WC 4WD Touring Car Kit	1
90005	SC10 4x4 Lucas Oil RTR (ready-to-run)	1
90006	SC10 4x4 Pro Comp RTR (ready-to-run)	1
90008	Limited Edition SC10 4x4 RTR Monster Energy	1
90010	SC10 4x4 FT Kit	1

:: 1/8 Kits and RTR's

20501	MGT 4.60 SE RTR (ready-to-run)	1
20502	MGT 8.0 Nitro RTR (ready-to-run)	1
20503	Limited Edition MGT 4.60 Nitro RTR, w/flag body (ready-to-run)	1
20504	Limited Edition MGT 8.0 Nitro RTR, w/flag body (ready-to-run)	1
80906	RC8.2 Nitro Buggy FT Kit	1
80907	RC8.2e Electric Buggy FT Kit	1
80908	RC8.2e Electric Buggy RTR (ready-to-run)	1
80909	RC8.2RS Nitro Buggy RTR (ready-to-run)	1
80912	RC8T Championship Edition	1
80933	SC8.2e Short Course Race Truck, Rockstar/Makita Electric RTR (ready-to-run)	1
80934	SC8.2e Short Course Race Truck, Slick Mist Electric RTR (ready-to-run)	1

:: Tools

1111	FT Turnbuckle Wrench	1
1112	FT 4mm Turnbuckle Wrench	1
1450	FT On Road Ride Height Gauge	1
1541	FT Hex Driver Set, (7 pcs)	1
1542	FT .050" Silver Hex Driver	1
1543	FT 1/16" Black Hex Driver	1
1544	FT 1.5mm Purple Hex Driver	1
1545	FT 5/64" Blue Hex Driver	1
1546	FT 3/32" Gold Hex Driver	1
1547	FT 2.5mm Green Hex Driver	1
1548	FT 3mm Red Hex Driver	1
1553	FT Phillips Silver Screwdriver	1
1554	FT Silver Spring Hook Tool	1
1561	FT Nut Driver Set, (6 pcs)	1
1562	FT 3/16" Black Nut Driver	1
1563	FT 1/4" Red Nut Driver	1
1564	FT 5.5mm Red Nut Driver	1
1565	FT 11/32" Green Nut Driver	1
1567	FT 8mm Gold Nut Driver	1
1589	FT 5/64" Blue Ball Hex Driver	1
1590	FT 3/32" Gold Ball Hex Driver	1
1592	FT Ball Hex Driver Set, (3 pcs)	1
1655	FT 8-Piece 1/4" Hex Drive Set	1
1656	FT 1/4" Hex Drive Handle, without tips	1
1657	FT 1/4" Hex Drive .050" Tip	1
1658	FT 1/4" Hex Drive 1/16" Tip	1
1659	FT 1/4" Hex Drive 5/64" - 2.0mm Tip	1
1660	FT 1/4" Hex Drive 3/32" Tip	1
1661	FT 1/4" Hex Drive 1.5mm Tip	1
1662	FT 1/4" Hex Drive 2.5mm Tip	1
1663	FT 1/4" Hex Drive 3/16" Nut Driver Tip	1
1664	FT 1/4" Hex Drive 1/4" Nut Driver Tip	1
1665	FT 1/4" Hex Drive 11/32" Nut Driver Tip	1
1666	FT 1/4" Hex Drive 5.5mm Nut Driver Tip	1
1667	FT 1/4" Hex Drive 7.0mm Nut Driver Tip	1
1668	FT 1/4" Hex Drive 8.0mm Nut Driver Tip	1
1669	FT 1/4" Hex Drive 5/64" - 2.0mm Ball End Tip	1
1670	FT 1/4" Hex Drive 3/32" Ball End Tip	1
1671	FT 1/4" Hex Drive Standard Screwdriver Tip	1
1672	FT 1/4" Hex Drive Phillips Screwdriver Tip	1
1673	FT 1/4" Hex Drive 2.5mm Ball End Tip	1
1674	FT 1/4" 5 Piece Power Tool Tips Set (5/64"-2.0mm, 1.5mm, 2.5mm, 5/64"- 2.0mm ball, 2.5mm ball)	1
1719	FT Camber + Track Width Tool	1
1737	FT Body Scissors	1
3718	12 Inch Nylon Wire Ties	12
3719	6 Inch Nylon Wire Ties	12
3720	8 Inch Nylon Wire Ties	12
3987	Composite Droop Gauge	1
6429	Shock Building Tool	1
6956	Molded Tools, Set	1
7494	V2 Stamped Multi-tool	1
7709	4 Inch Nylon Wire Ties	12

:: Apparel

SP31**	27 Time WC T-Shirt, Black (S, M, L, XL, 2XL, 3XL)	1
SP32**	Kids AE 2012 T-Shirt, Blue (S, M, L)	1
SP37**	Reedy 2012 T-shirt - Black (S, M, L, XL, 2XL, 3XL)	1
SP38	Reedy Trucker Hat	1
SP39	Reedy Patch	1
SP71**	Associated Winter Jacket (M, L, XL)	1
SP77**	AE 2012 T-Shirt, Blue (S, M, L, XL, 2XL, 3XL)	1
SP78**	AE 2012 T-Shirt, White (S, M, L, XL, 2XL, 3XL)	1
SP79**	AE 2012 T-Shirt, Black (S, M, L, XL, 2XL, 3XL)	1
SP84**	Reedy 3D T-Shirt, Black (S, M, L, XL, 2XL, 3XL)	1
SP86**	Reedy Womens 3D T-Shirt, Black (S, M, L, XL)	1
SP90**	AE Retro T-Shirt, Blue (S, M, L, XL, 2-5XL)	1
SP91**	AE Retro T-Shirt, Black (S, M, L, XL, 2-5XL)	1
SP92**	AE Retro T-Shirt, White (S, M, L, XL, 2-5XL)	1
SP93**	2013 Worlds T-Shirt, Blue (S, M, L, XL, 2-5XL)	1
SP94**	2013 Worlds T-Shirt, Black (S, M, L, XL, 2-5XL)	1
SP95**	2013 Worlds Hoodie, Black (S, M, L, XL, 2-3XL)	1
SP96**	AE Retro Womens T-Shirt, Pink (S, M, L, XL)	1
SP97**	AE Womens T-Shirt, Black (S, M, L, XL)	1
SP98	AE Trucker Hat	1
SP99	AE Patch	1
SP411S	AE Hat 11' Flat Bill Black S/M	1
SP411L	AE Hat 11' Flat Bill Black L/XL	1
SP416	Associated Car Carrier Bag, Medium	1
SP417	1/10 FT Motor Bag	1
SP420**	AE Pit Gloves (L, XL)	Pr.
SP421S	AE 2012 Hat, Black, Flat Bill, S/M	1
SP421L	AE 2012 Hat, Black, Flat Bill, L/XL	1
SP422S	AE 2012 Hat, Black, Curved Bill, S/M	1
SP422L	AE 2012 Hat, Black, Curved Bill, L/XL	1
SP423S	AE 2012 Hat, White, Flat Bill, S/M	1
SP423L	AE 2012 Hat, White, Flat Bill, L/XL	1
SP424S	AE 2012 Hat, White, Curved Bill, S/M	1
SP424L	AE 2012 Hat, White, Curved Bill, L/XL	1
715	Reedy 2009 Track Banner	1
110684	Team Associated Track Banner	1

:: Contact Information

Associated Electrics, Inc.
26021 Commercentre Drive
Lake Forest, CA 92630-8853 USA
<http://www.TeamAssociated.com>
<http://www.RC10.com>
[http://twitter/Team Associated](http://twitter/TeamAssociated)
<http://bit.ly/AEonFacebook>

call: (949) 544-7500

fax: (949) 544-7501

Check out the following web sites for all of our electric kits, current products, new releases, setup help, tips, and racing info!

www.TeamAssociated.com - www.RC10.com

:: Notes

A large, empty rectangular area intended for taking notes, framed by a thin black border.

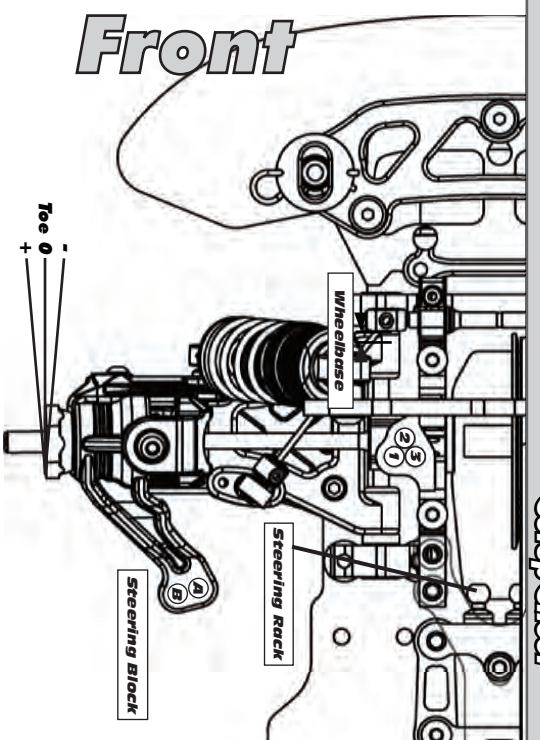

Front	Alignment	Rear
5.0mm	Ride Height	5.2mm
-2 Deg	Camber	-2 Deg
4 Deg	Caster	N/A
N/A	Rear Hub Toe	0 Deg
+ 0.5 Deg	Toe (Total)	-3 Deg
0	Hex Spacing	0
1mm	Wheelbase	1mm
Silver + 1mm	Steering Rack	N/A
B	Ball & Shims	N/A
Black	Steering Block Position	N/A
	Steering Block Ball & Shims	N/A

Notes:

Suspension Geometry	
2B	Shock Position
1	Camber Link Position
Black + 2mm	Inner Ball & Shims
Silver	Outer Ball & Shims
1 Dot	Outer Arm Mount Insert
0.5mm	Outer Mount Shims
1 Dot	Inner Arm Mount Insert
0.5mm	Inner Mount Shims
6	Droop
1.1mm (Yellow)	Anti-Roll Bar

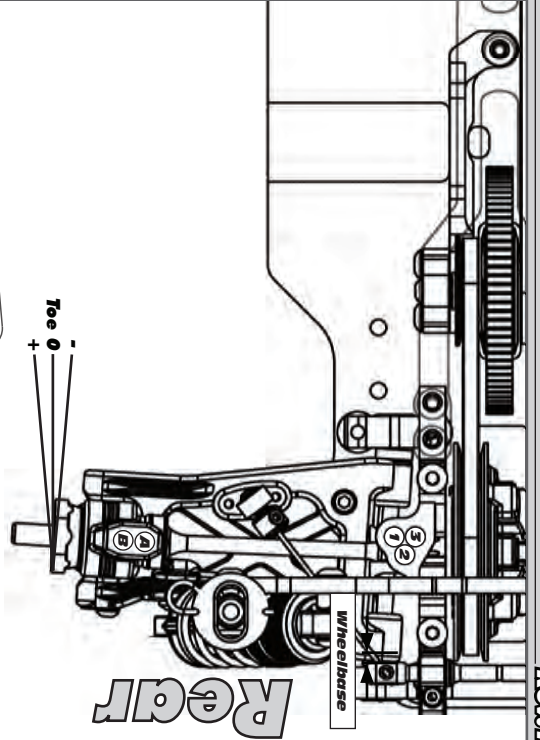

Notes:

Shocks	
40wt	Oil
#2	Piston
25%	Rebound
Silver	Spring

Notes:

Differentials		
Spool	Type	Gear
	Setting	40wt
Mid-Low	Cam Position	Mid-Low
8	Belt Tension Number	7

Notes:

Tires	
	Type
	Tire Diameter
	Insert & Wheel
	Additive & Amount

Notes:

Chassis	
	Top Plate:

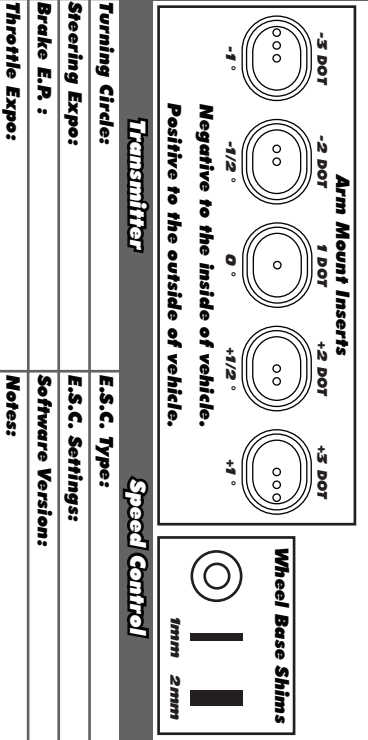

Notes:

Transmitter	
	Turning Circle:
	Steering Expo:
	Brake E.R.:
	Throttle Expo:

Notes:

Speed Control	
	E.S.C. Type:
	E.S.C. Settings:
	Software Version:
	Battery Placement
	Body & Wing

Notes:

Motor	
	Gearing

For more setups, visit RC10.com and click on "Setup Sheets"

:: Hardware - 1:1 Scale View

Cap Head (shcs)

 **2x5mm (31511)**

Set screw

 **3x2.5mm (31500)**

 **4x8mm (25227)**

Ballstuds

 **(Ti Nitride 3.25mm short 31374)**

 **Black 5mm short (31280)**
(Ti Nitride 5mm short, 31288)

 **Silver 8mm short (31283)**
(Ti Nitride 5mm long, 31291)

 **Black 8mm short (31281)**
(Ti Nitride 8mm short, 31289)

 **Silver 8mm long (31284)**
(Ti Nitride 8mm long, 31292)

 **Black 10mm short (31285)**
(Ti Nitride 10mm short, 31290)

 **Silver 10mm long (31285)**
(Ti Nitride 10mm long, 31293)

Nuts (lock/plain)

 **2-56 locknut (3904)**

 **M3 locknut (31550)**

 **M4 locknut (91148)**

Flat Head (fhcs)

 **2.5x10mm (31350)**

 **3x5mm (31540)**

 **3x6mm (31541)**

 **3x8mm (25201)**

 **3x10mm (25202)**

 **3x12mm (25203)**

 **3x16mm (25204)**

Shims and Washers

 **1mm and 2mm blue shims (31286)**

 **Diff washer (31166)**

 **1mm and 2mm wheelbase shims (31200)**

 **Thrust washer (6573)**

 **Gold washer (7337)**

 **Bulkhead Shim (4617)**
0.5mm, 1mm, 2mm

 **Diff shim (31162)**

Button Head (bhcs)

 **2x4mm (31510)**

 **2x5mm (31511)**

 **2.5x4mm (4673)**

 **2.5x6mm (4675)**

 **2.5x8mm (31521)**

 **3x5mm (31530)**

 **3x6mm (31531)**

 **3x8mm (31532)**

 **3x10mm (25211)**

 **3x12mm (89202)**

 **3x14mm (25187)**

 **3x16mm (89203)**

Ball Bearings

 **4x7mm (31403)**

 **4x8x3mm flanged (31331)**

 **5x8mm (31400)**

 **5x10mm (25237)**

 **10x15mm (31401)**

Clips

 **3mm E-clip (31160)**

 **C-clip (31307)**

Notes:

Drivers _____

Tracks _____

Conditions: _____

Event: _____

Date: _____

Rev1

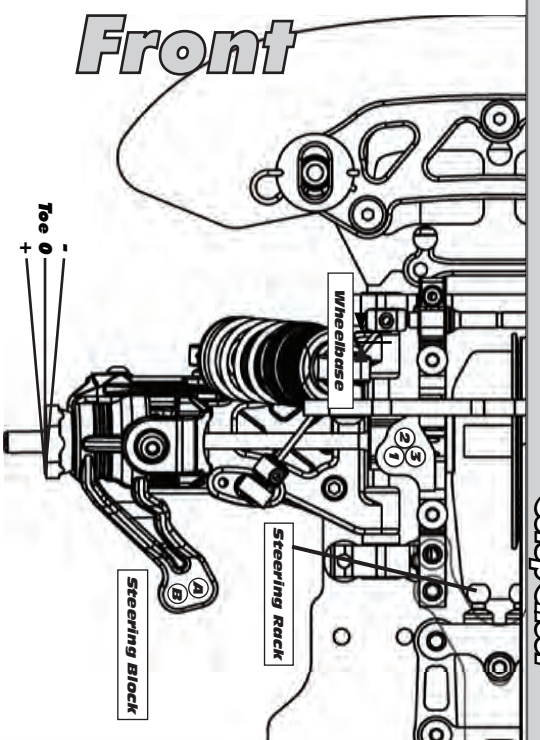

Front	Alignment	Rear
	Ride Height	
	Camber	
	Caster	N/A
N/A	Rear Hub Toe	
	Toe (Total)	
	Hex Spacing	
	Wheelbase	
	Steering Rack	N/A
	Ball & Shims	N/A
	Steering Block Position	N/A
	Steering Block Ball & Shims	N/A

Notes:

Suspension Geometry
Shock Position
Camber Link Position
Inner Ball & Shims
Outer Ball & Shims
Outer Arm Mount Insert
Outer Mount Shims
Inner Arm Mount Insert
Inner Mount Shims
Droop
Anti-Roll Bar

Notes:

Shocks
Oil
Piston
Rebound
Spring

Notes:

Differentials
Type
Setting
Cam Position
Belt Tension Number

Notes:

Tires
Type
Tire Diameter
Insert & Wheel
Additive & Amount

Notes:

Chassis
Top Plate:

Notes:

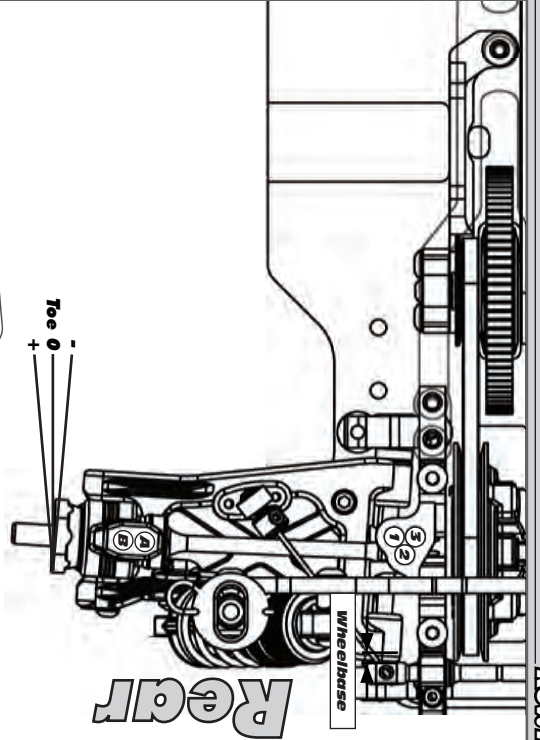

Front	Alignment	Rear
	Ride Height	
	Camber	
	Caster	N/A
N/A	Rear Hub Toe	
	Toe (Total)	
	Hex Spacing	
	Wheelbase	
	Steering Rack	N/A
	Ball & Shims	N/A
	Steering Block Position	N/A
	Steering Block Ball & Shims	N/A

Notes:

Suspension Geometry
Shock Position
Camber Link Position
Inner Ball & Shims
Outer Ball & Shims
Outer Arm Mount Insert
Outer Mount Shims
Inner Arm Mount Insert
Inner Mount Shims
Droop
Anti-Roll Bar

Notes:

Shocks
Oil
Piston
Rebound
Spring

Notes:

Differentials
Type
Setting
Cam Position
Belt Tension Number

Notes:

Tires
Type
Tire Diameter
Insert & Wheel
Additive & Amount

Notes:

Chassis
Top Plate:

Notes:

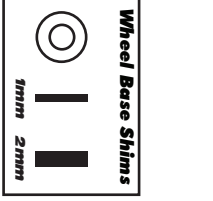
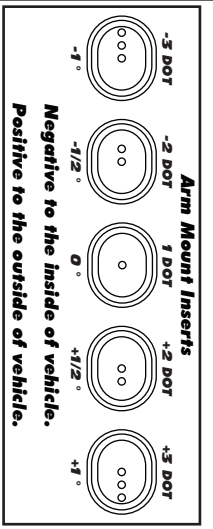
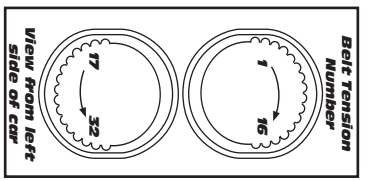
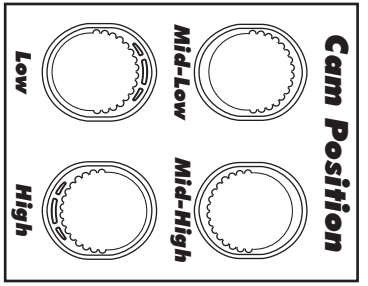

Transmitter

Speed Control

Turning Circle: _____ E.S.C. Type: _____

Steering Expo: _____ E.S.C. Settings: _____

Brake E.P. : _____ Software Version: _____

Throttle Expo: _____ Notes: _____

Battery Placement _____ Body & Wing _____

Notes: _____



**Associated Electrics, Inc.
26021 Commercentre Dr.
Lake Forest, CA 92630 USA**

<http://www.TeamAssociated.com>

<https://www.RC10.com>

https://twitter/Team_Associated

<https://bit.ly/AEonFacebook>

call: (949) 544-7500 - fax: (949) 544-7501

**Check out the following web sites for all of our kits,
current products, new releases, setup help, tips, and racing info!
www.TeamAssociated.com - www.RC10.com**