

XRAY T3 2012

1/10 LUXURY ELECTRIC TOURING CAR



Full
DESIGN
PURE
ADRENALINE
PURE
RACING

T3 2012 INSTRUCTION MANUAL



BEFORE YOU START

The T3 is a high-competition, high-quality, 1/10-scale touring car intended for persons aged 16 years and older with previous experience building and operating RC model racing cars. This is not a toy; it is a precision racing model. This model racing car is not intended for use by beginners, inexperienced customers, or by children without direct supervision of a responsible, knowledgeable adult. If you do not fulfill these requirements, please return the kit in unused and unassembled form back to the shop where you have purchased it.

Before building and operating your T3, YOU MUST read through all of the operating instructions and instruction manual and fully understand them to get

CUSTOMER SUPPORT

We have made every effort to make these instructions as easy to understand as possible. However, if you have any difficulties, problems, or questions, please do not hesitate to contact the XRAY support team at info@teamxray.com. Also, please visit our Web site at www.teamxray.com to find the latest updates, set-up information, option parts, and many other goodies. We pride ourselves on taking excellent care of our customers.

You can join thousands of XRAY fans and enthusiasts in our online community at: www.teamxray.com

the maximum enjoyment and prevent unnecessary damage. Read carefully and fully understand the instructions before beginning assembly.

Make sure you review this entire manual, the included set-up book, and examine all details carefully. If for some reason you decide The T3 is not what you wanted or expected, do not continue any further. Your hobby dealer cannot accept your T3 kit for return or exchange after it has been partially or fully assembled.

Contents of the box may differ from pictures. In line with our policy of continuous product development, the exact specifications of the kit may vary without prior notice.

XRAY Europe

K Vystavisku 6992
91101 Trenčín
Slovakia, EUROPE
Phone: 421-32-7401100
Fax: 421-32-7401109
E-mail: info@teamxray.com

XRAY USA

RCAmerica, 2970 Blystone Lane, Suite 109
Dallas, Texas 75220
USA
Phone: (800) 519-7221 * (214) 744-2400
Fax: (214) 744-2401
E-mail: xray@rcamerica.com

Failure to follow these instructions will be considered as abuse and/or neglect.

SAFETY PRECAUTIONS

Contains:

LEAD (CAS 7439-92-1) ANTIMONY (CAS 7440-36-0)

WARNING: This product contains a chemical known to the state of California to cause cancer and birth defects or other reproductive harm.

CAUTION: CANCER HAZARD

Contains lead, a listed carcinogen. Lead is harmful if ingested. Wash thoroughly after using. DO NOT use product while eating, drinking or using tobacco products. May cause chronic effects to gastrointestinal tract, CNS, kidneys, and blood. MAY CAUSE BIRTH DEFECTS.

When building, using and/or operating this model always wear protective glasses and gloves.

Take appropriate safety precautions prior to operating this model. You are responsible for this model's assembly and safe operation! Please read the instruction manual before building and operating this model and follow all safety precautions. Always keep the instruction manual at hand for quick reference, even after completing the assembly. Use only genuine and original authentic XRAY parts for maximum performance. Using any third party parts on this model will void guaranty immediately.

Improper operation may cause personal and/or property damage. XRAY and its distributors have no control over damage resulting from shipping, improper construction, or improper usage. XRAY assumes and accepts no responsibility for personal and/or property damages resulting from the use of improper building materials, equipment and operations. By purchasing any item produced by XRAY, the buyer expressly warrants that he/she is in compliance with all applicable federal, state and local laws and regulation regarding the purchase, ownership and use of the item. The buyer expressly agrees to indemnify and hold harmless XRAY for all claims resulting directly or indirectly from the purchase, ownership or use of the product. By the act of assembling or operating this product, the user accepts all resulting liability. If the buyer is not prepared to accept this liability, then he/she should return this kit in new, unassembled, and unused condition to the place of purchase.

IMPORTANT NOTES - GENERAL

- This product is not suitable for children under 16 years of age without the direct supervision of a responsible and knowledgeable adult.
 - Carefully read all manufacturers warnings and cautions for any parts used in the construction and use of your model.
 - Assemble this kit only in places away from the reach of very small children.
 - First-time builders and users should seek advice from people who have building experience in order to assemble the model correctly and to allow the model to reach its performance potential.
 - Exercise care when using tools and sharp instruments.
 - Take care when building, as some parts may have sharp edges.
 - Keep small parts out of reach of small children. Children must not be allowed to put any parts in their mouth, or pull vinyl bag over their head.
 - Read and follow instructions supplied with paints and/or cement, if used (not included in kit).
 - Immediately after using your model, do NOT touch equipment on the model such as the motor and speed controller, because they generate high temperatures. You may seriously burn yourself seriously touching them.
 - Follow the operating instructions for the radio equipment at all times.
 - Do not put fingers or any objects inside rotating and moving parts, as this may cause damage or serious injury as your finger, hair, clothes, etc. may get caught.
 - Be sure that your operating frequency is clear before turning on or running your model, and never share the same frequency with somebody else at the same time. Ensure that others are aware of the operating frequency you are using and when you are using it.
 - Use a transmitter designed for ground use with RC cars. Make sure that no one else is using the same frequency as yours in your operating area. Using the same frequency at the same time, whether it is driving, flying or sailing, can cause loss of control of the RC model, resulting in a serious accident.
 - Always turn on your transmitter before you turn on the receiver in the car. Always turn off the receiver before turning your transmitter off.
 - Keep the wheels of the model off the ground when checking the operation of the radio equipment.
 - Disconnect the battery pack before storing your model.
 - When learning to operate your model, go to an area that has no obstacles that can damage your model if your model suffers a collision.
 - Remove any sand, mud, dirt, grass or water before putting your model away.
 - If the model behaves strangely, immediately stop the model, check and clear the problem.
 - To prevent any serious personal injury and/or damage to property, be responsible when operating all remote controlled models.
 - The model car is not intended for use on public places and roads or areas where its operation can conflict with or disrupt pedestrian or vehicular traffic.
 - Because the model car is controlled by radio, it is subject to radio interference from many sources that are beyond your control. Since radio interference can cause momentary loss of control, always allow a safety margin in all directions around the model in order to prevent collisions.
 - Do not use your model:
 - Near real cars, animals, or people that are unaware that an RC car is being driven.
 - In places where children and people gather
 - In residential districts and parks
 - In limited indoor spaces
 - In wet conditions
 - In the street
 - In areas where loud noises can disturb others, such as hospitals and residential areas.
 - At night or anytime your line of sight to the model may be obstructed or impaired in any way.
- To prevent any serious personal injury and/or damage to property, please be responsible when operating all remote controlled models.

IMPORTANT NOTES - ELECTRICAL

- Insulate any exposed electrical wiring (using heat shrink tubing or electrical tape) to prevent dangerous short circuits. Take maximum care in wiring, connecting and insulating cables. Make sure cables are always connected securely. Check connectors for if they become loose. And if so, reconnect them securely. Never use R/C models with damaged wires. A damaged wire is extremely dangerous, and can cause short-circuits resulting in fire. Please have wires repaired at your local hobby shop.
- Low battery power will result in loss of control. Loss of control can occur due to a weak battery in either the transmitter or the receiver. Weak running battery may also result in an out of control car if your car's receiver power is supplied by the running battery. Stop operation immediately if the car starts to slow down.
- When not using RC model, always disconnect and remove battery.
- Do not disassemble battery or cut battery cables. If the running battery short-circuits, approximately 300W of electricity can be discharged, leading to fire or burns. Never disassemble battery or cut battery cables.
- Use a recommended charger for the receiver and transmitter batteries and follow the instructions correctly. Over-charging, incorrect charging, or using inferior chargers can cause the batteries to become dangerously hot.

Recharge battery when necessary. Continual recharging may damage battery and, in the worst case, could build up heat leading to fire. If battery becomes extremely hot during recharging, please ask your local hobby shop for check and/or repair and/or replacement.

- Regularly check the charger for potential hazards such as damage to the cable, plug, casing or other defects. Ensure that any damage is rectified before using the charger again. Modifying the charger may cause short-circuit or overcharging leading to a serious accident. Therefore do not modify the charger.
- Always unplug charger when recharging is finished.
- Do not recharge battery while battery is still warm. After use, battery retains heat. Wait until it cools down before charging.
- Do not allow any metal part to short circuit the receiver batteries or other electrical/electronic device on the model.
- Immediately stop running if your RC model gets wet as may cause short circuit.
- Please dispose of batteries responsibly. Never put batteries into fire.

R/C & BUILDING TIPS

- Make sure all fasteners are properly tightened. Check them periodically.
- Make sure that chassis screws do not protrude from the chassis.
- For the best performance, it is very important that great care is taken to ensure the free movement of all parts.
- Clean all ball-bearings so they move very easily and freely.
- Tap or pre-thread the plastic parts when threading screws.
- Self-tapping screws cut threads into the parts when being tightened. Do not use excessive force when tightening the self-tapping screws because you may strip out the thread in the plastic. We recommended you stop tightening a screw when you feel some resistance.
- Ask your local hobby shop for any advice.

Please support your local hobby shop. We at XRAY Model Racing Cars support all local hobby dealers. Therefore we ask you, if at all possible, to purchase XRAY products at your hobby dealer and give them your support like we do. If you have difficulty finding XRAY products, please check out www.teamxray.com to get advice, or contact us via email at info@teamxray.com, or contact the XRAY distributor in your country.

WARRANTY

XRAY guarantees this model kit to be free from defects in both material and workmanship within 30 days of purchase. The total monetary value under warranty will in no case exceed the cost of the original kit purchased. This warranty does not cover any components damaged by use or modification or as a result of wear. Part or parts missing from this kit must be reported within 30 days of purchase. No part or parts will be sent under warranty without proof of purchase. Should you find a defective or missing part, contact the local distributor. Service and customer support will be provided through local hobby store where you have purchased the kit, therefore make sure to purchase any XRAY products at your local hobby store. This model racing car is considered to be a high-performance racing vehicle. As such this vehicle will be used in an extreme range of conditions and situations, all which may cause premature wear or failure of any component. XRAY has no control over usage of vehicles once they leave the dealer, therefore XRAY can only offer warranty against all manufacturer's defects in materials, workmanship, and assembly at point of sale and before use. No warranties are expressed or implied that cover damage caused by what is considered normal use, or cover or imply how long any model cars' components or electronic components will last before requiring replacement.

Due to the high performance level of this model car you will need to periodically maintain and replace consumable components. Any and all warranty coverage will not cover replacement of any part or component damaged by neglect, abuse, or improper or unreasonable use. This includes but is not limited to

damage from crashing, chemical and/or water damage, excessive moisture, improper or no maintenance, or user modifications which compromise the integrity of components. Warranty will not cover components that are considered consumable on RC vehicles. XRAY does not pay nor refund shipping on any component sent to XRAY or its distributors for warranty. XRAY reserves the right to make the final determination of the warranty status of any component or part.

Limitations of Liability

XRAY makes no other warranties expressed or implied. XRAY shall not be liable for any loss, injury or damages, whether direct, indirect, special, incidental, or consequential, arising from the use, misuse, or abuse of this product and/or any product or accessory required to operate this product. In no case shall XRAY's liability exceed the monetary value of this product.

Take adequate safety precautions prior to operating this model. You are responsible for this model's assembly and safe operation.

Disregard of the any of the above cautions may lead to accidents, personal injury, or property damage. XRAY MODEL RACING CARS assumes no responsibility for any injury, damage, or misuse of this product during assembly or operation, nor any addictions that may arise from the use of this product. All rights reserved.

QUALITY CERTIFICATE

XRAY MODEL RACING CARS uses only the highest quality materials, the best compounds for molded parts and the most sophisticated manufacturing processes of TQM (Total Quality Management). We guarantee that all parts of a newly-purchased kit are manufactured with the highest regard to quality. However, due to the many factors inherent in model racecar competition, we cannot guarantee

any parts once you start racing the car. Products which have been worn out, abused, neglected or improperly operated will not be covered under warranty. We wish you enjoyment of this high-quality and high-performance RC car and wish you best success on the track!

In line with our policy of continuous product development, the exact specifications of the kit may vary. In the unlikely event of any problems with your new kit, you should contact the model shop where you purchased it, quoting the part number.

We do reserve all rights to change any specification without prior notice. All rights reserved.

CONTENTS

WARNINGS	2-3	4. STEERING	14-15
TOOLS AND ACCESSORIES	4	5. FRONT & REAR TRANSMISSION	16-20
0. KIT	5	6. SHOCK ABSORBERS	21-23
1. GEAR DIFF. & FRONT SOLID AXLE	6-8	7. FRONT & REAR ASSEMBLY	24-27
2. CENTRAL TRANSMISSION	9-11	7. FINAL ASSEMBLY	28-30
3. FRONT & REAR SUSPENSION	12-14	BLANK SET-UP SHEET	31

SYMBOLS USED

Part bags used 	Assemble in the specified order 	Assemble left and right sides the same way 	Pay attention here 	Assemble as many times as specified (here twice) 	Apply thread lock 	Apply CA glue
Apply oil 	Apply grease 	Use pliers 	Ensure smooth non-binding movement 	Tighten screw gently 	CORRECT WRONG Overtightened The threads are stripped.	Follow Set-Up Book

TOOLS REQUIRED

HUDY TOOLS: Allen: 1.5mm, 2.0mm, 3.0mm Socket: 5.5mm, 7.0mm 	Combination Pliers (HUDY #189020) Snap Ring Pliers (HUDY #189040) 	Side Cutters (HUDY #189010) 	Hobby Knife Scissors (HUDY #188990) 	Turnbuckle Wrench 3mm (HUDY #181030) 4mm (HUDY #181040) 	Reamer (HUDY #107600) or (HUDY #107601)
---	--	---	---	--	---

EQUIPMENT INCLUDED

XRAY Premium Silicone Oil 350cSt (#359235) Oil 700cSt (#359270) 	Graphite Grease (HUDY #106210)
--	---

NOT INCLUDED

 To ensure that you always have access to the most up-to-date version of the XRAY Set-up Book, XRAY will now be offering only the digital online version at our Web site at www.teamxray.com. By offering this online version instead of including a hardcopy printed version in kits, you will always be assured of having the most current updated version.

EQUIPMENT REQUIRED

Transmitter 	Receiver 	Steering Servo 	Electric Motor & Pinion Gear and Setscrew 	Bearing Oil (HUDY #106230) 	Speed Controller
190mm Bodyshell 	LiPo Battery 	Lexan Paint™ 	Battery Charger 	Fibre Tape (HUDY #107870) Double-sided Tape 	Wheels & Tires & Inserts

0. KIT (FACTORY PRE-ASSEMBLED)

COLOR INDICATIONS

At the beginning of each section is an exploded view of the parts to be assembled. There is also a list of all the parts and part numbers that are related to the assembly of that section.

The part descriptions are color-coded to make it easier for you to identify the source of a part. Here are what the different colors mean:

STYLE A - indicates parts that are included in the bag marked for the section.

STYLE B - indicates parts that were set aside in Section 0.

STYLE C - indicates parts that are already assembled from previous steps.

REAR

FRONT

301132
903306
302027-O
303014-O
303022-O
303022-O
303052-O
903306
302027-O

KIT	30 1132	T3'12 CHASSIS 2.5MM GRAPHITE	30 3052-O	T3 ALU MOTOR MOUNT BULKHEAD - ORANGE
	30 2027-O	T3 ALU FRONT LOWER SUSP. ADJUST. BULKHEAD - ORANGE	90 3306	HEX SCREW SFH M3x6 (10)
	30 3014-O	T3 ALU RIGHT LAYSHAFT BULKHEAD - ORANGE		
	30 3022-O	T3 ALU REAR LOWER SUSP. ADJUST. BULKHEAD - ORANGE		

The XRAY T3 comes partially pre-assembled. Before starting assembly, disassemble the chassis parts, noting the position and orientation of the parts, particularly the bulkheads. Keep the parts, including the screw hardware, close at hand. In the assembly steps that follow, each section begins with a parts list. Parts indicated with **STYLE B** are from the previously disassembled chassis parts in section 0.

To protect and seal edges of graphite parts, sand edges smooth and then apply CA glue.

Do this for: chassis edges; filed battery slots, countersunk holes.

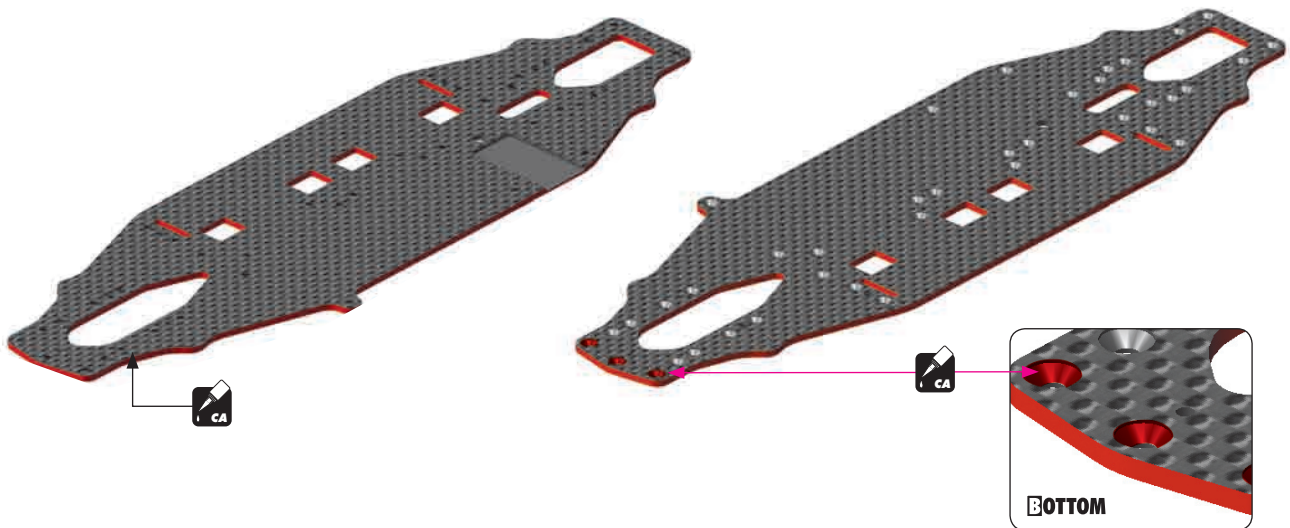

Apply only a bit of CA glue on the countersunk holes

1. GEAR DIFFERENTIAL & FRONT SOLID AXLE

01.2

GEAR DIFFERENTIAL



#304971
Optional HUDY Spring Steel™ outrives

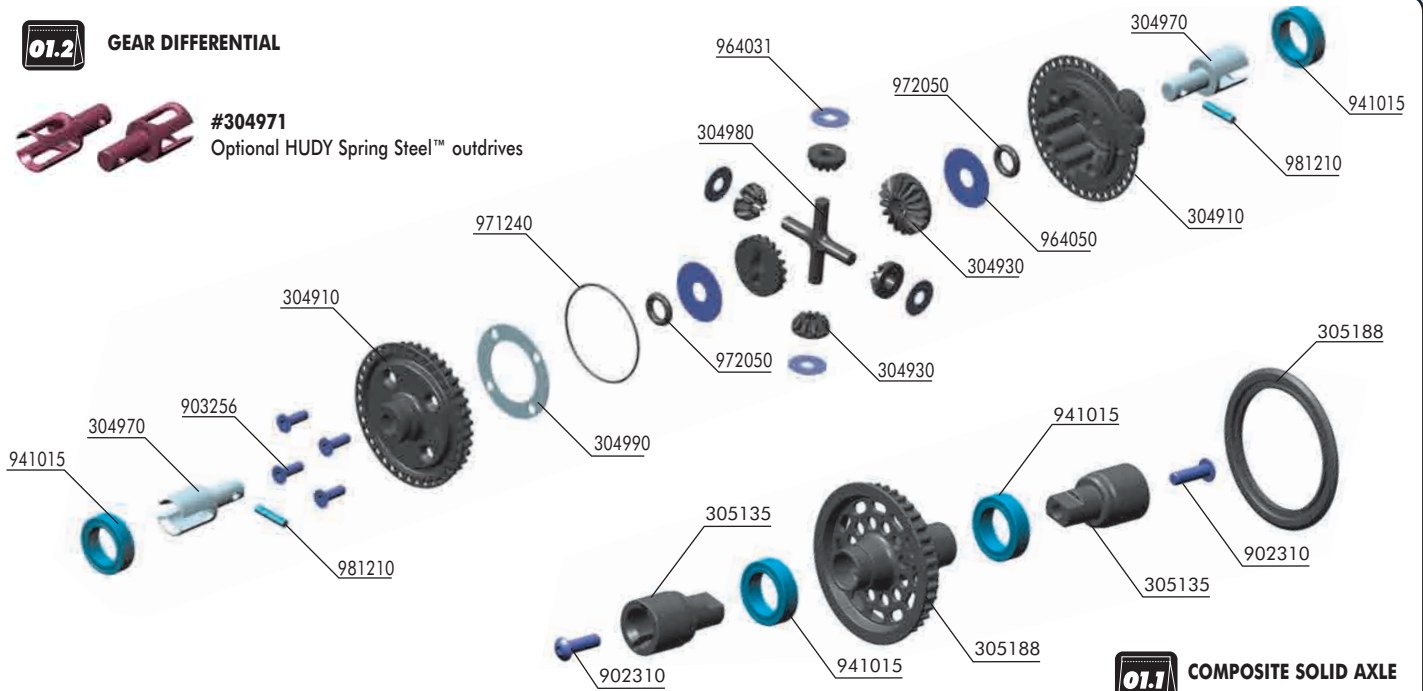

#305136

Optional ALU SOLID DRIVESHAFT ADAPTERS



#305137

Optional STEEL SOLID AXLE DRIVESHAFT ADAPTERS

01.1

COMPOSITE SOLID AXLE

BAG

01.1

01.2

- 30 4900 XRAY GEAR DIFFERENTIAL - SET
- 30 4910 COMPOSITE GEAR DIFF. CASE & COVER
- 30 4930 COMPOSITE GEAR DIFF BEVEL & SATELLITE GEARS (2+4)
- 30 4970 ALU GEAR DIFF OUTDRIVE ADAPTER - 7075 T6 (2)
- 30 4990 DIFF GASKET (4)
- 30 4980 COMPOSITE GEAR DIFF CROSS PIN
- 30 5003 ALU BALL DIFFERENTIAL 34T + 38T PULLEY (OPTION)
- 30 5105 XRAY MULTI-DIFF T3 LiPo (OPTION)
- 30 5135 COMPOSITE SOLID AXLE DRIVESHAFT ADAPTERS (2)

- 30 5188 COMPOSITE SOLID AXLE 38T - SET
- 90 2310 HEX SCREW SH M3x10 (10)
- 90 3256 HEX SCREW SFH M2.5x6 (10)
- 94 1015 HIGH-SPEED BALL-BEARING 10x15x4 RUBBER SEALED (2)
- 96 4031 WASHER S 3.5x10x0.2 (10)
- 96 4050 WASHER S 5x15x0.3 (10)
- 97 1240 SILICONE O-RING 24x0.7 (10)
- 97 2050 SILICONE O-RING 5x2 (10)
- 98 1210 PIN 2x10 (10)



964050
S 5x15x0.3



972050
O 5x2

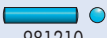

981210
P 2x10

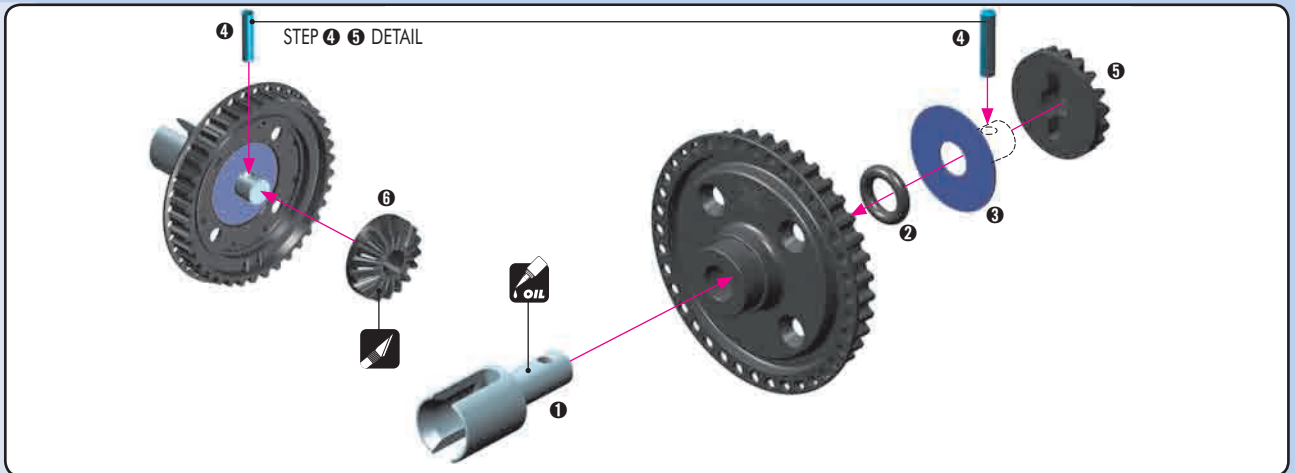

964050
S 5x15x0.3



972050
O 5x2



981210
P 2x10

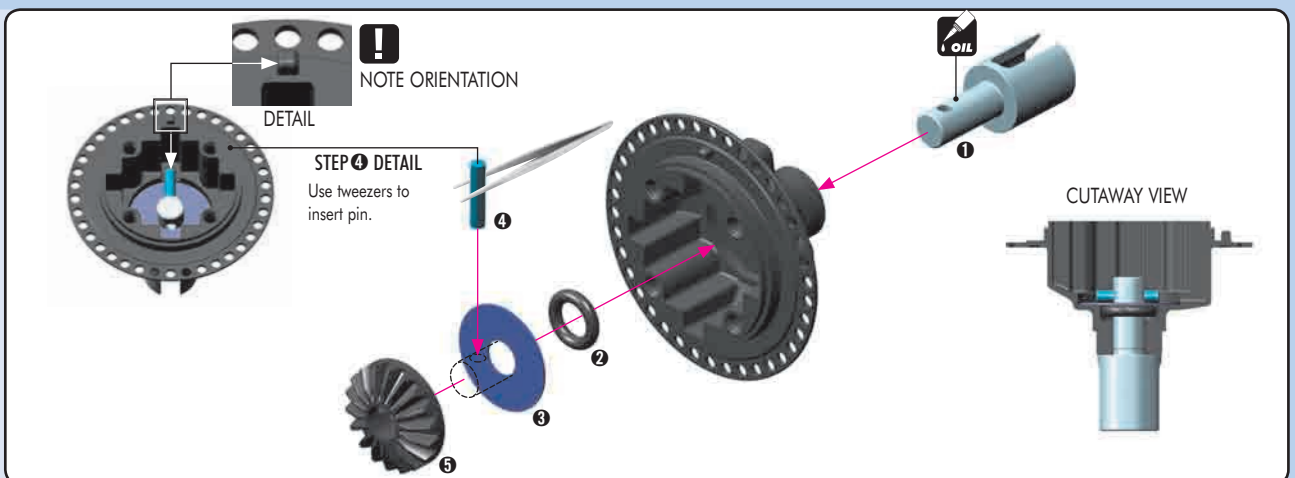

1. GEAR DIFFERENTIAL & FRONT SOLID AXLE



964031
S 3.5x10x0.2

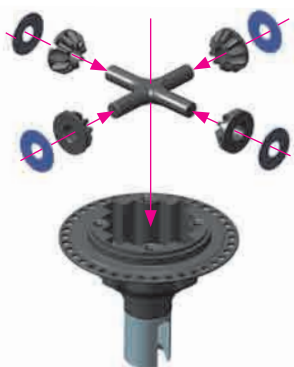

Fill differential up to the top of the diff pin. DO NOT fill the diff to the top of the housing.

TO ENSURE YOU HAVE THE SAME AMOUNT OF OIL FROM REBUILD TO REBUILD, DO THE FOLLOWING:



7.90g

#107865

HUDY Ultimate Digital Pocket Scale 300g±0.01g



9.20g



$$7.90g + 1.3g = 9.20G$$

❶ Put the diff (without oil) on the scale and check the weight (approximately 7.90g)

❷ Slowly pour oil into the diff and watch the weight. Add 1.3g of oil into the diff. The approximate weight of the diff + oil is 9.20g.

TIPS FOR DIFFERENTIALS

LOW-TRACTION

600cst
700cst
800cst

NOTE: softer oil increases rear traction, harder oil increases on-power steering.

HIGH-TRACTION

900cst
1000cst
2000cst

TIPS FOR FRONT DIFFERENTIAL

To increase on-power steering and cornering speed, the gear diff can also be used in the front. Note: If you use the gear diff in the front, we recommend using optional #304971 HUDY Spring Steel™ outdrives because the stress on the outdrives in the front is much higher than in the rear.

USE THESE OILS FOR FRONT DIFFERENTIAL:

300,000 cst

To make the front differential tighter, you can use cleaning gum instead of oil. **IMPORTANT!** Using cleaning gum instead of oil in the gear differential can lead to gear breakage because the gears are working under dry conditions.

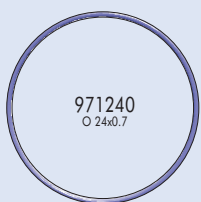

After disassembling the gear diff the large O-ring may have an increased size and may be more difficult to re-install. We recommend either inserting the old O-ring carefully in the diff cover, or replacing the old O-ring with a new O-ring if the old one cannot be made to fit properly.



903256
SFH M2.5x6

BOTTOM DETAIL



NOTE
ORIENTATION



DETAIL

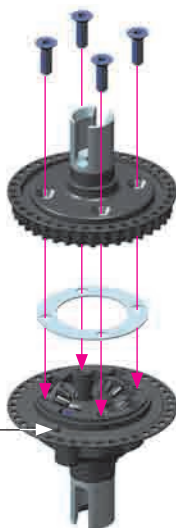

Tighten the screws equally but do NOT tighten them completely

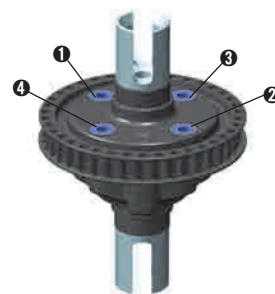

Finish tightening in this order

1. GEAR DIFFERENTIAL & FRONT SOLID AXLE



941015
BB 10x15x4

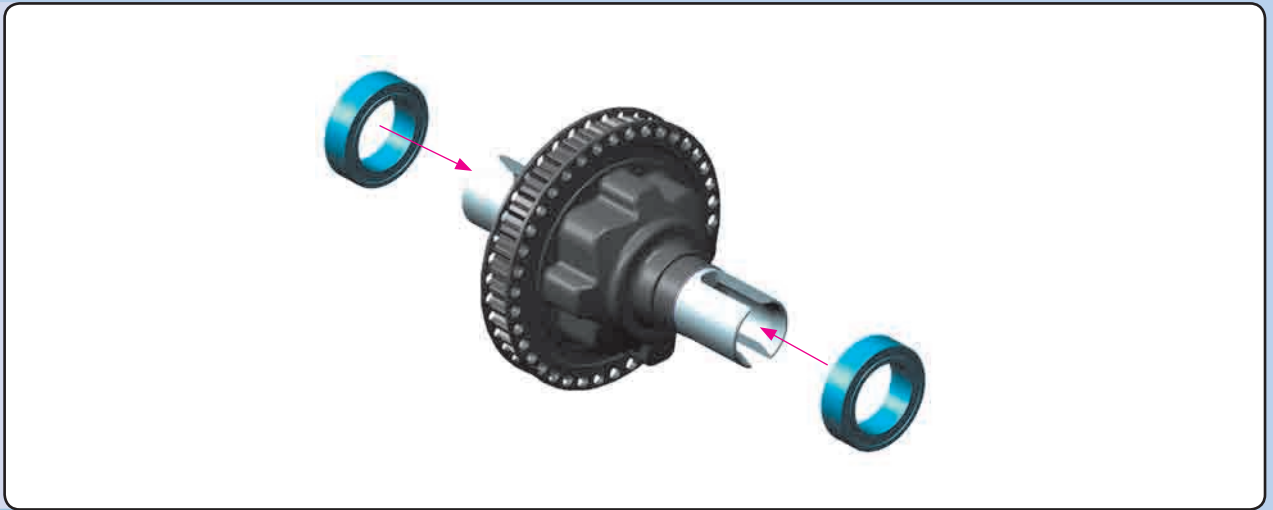

COMPOSITE FRONT SOLID AXLE



902310
SH M3x10

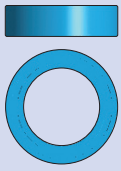

941015
BB 10x15x4

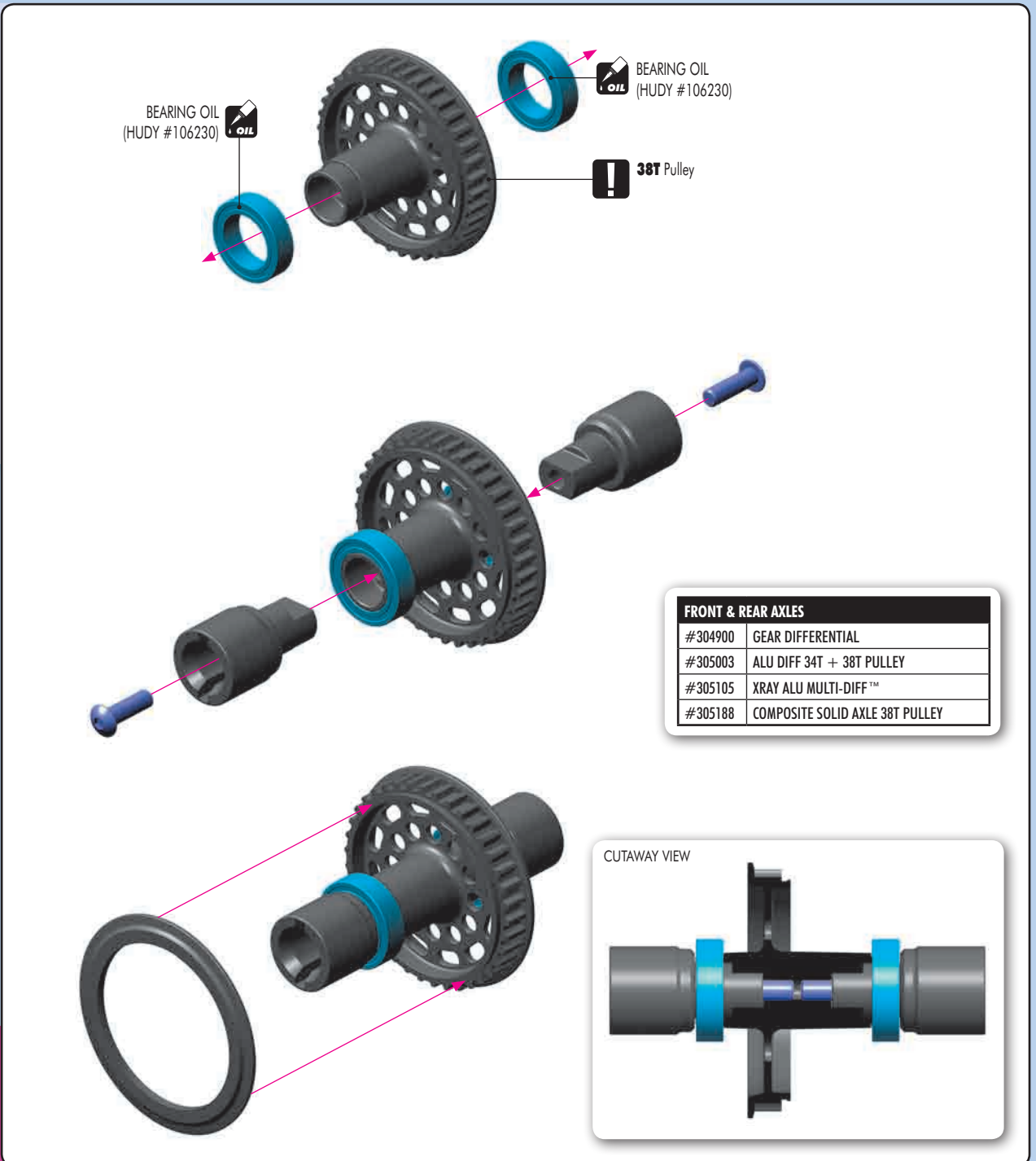

FRONT & REAR AXLES	
#304900	GEAR DIFFERENTIAL
#305003	ALU DIFF 34T + 38T PULLEY
#305105	XRAY ALU MULTI-DIFF™
#305188	COMPOSITE SOLID AXLE 38T PULLEY



2. CENTRAL TRANSMISSION

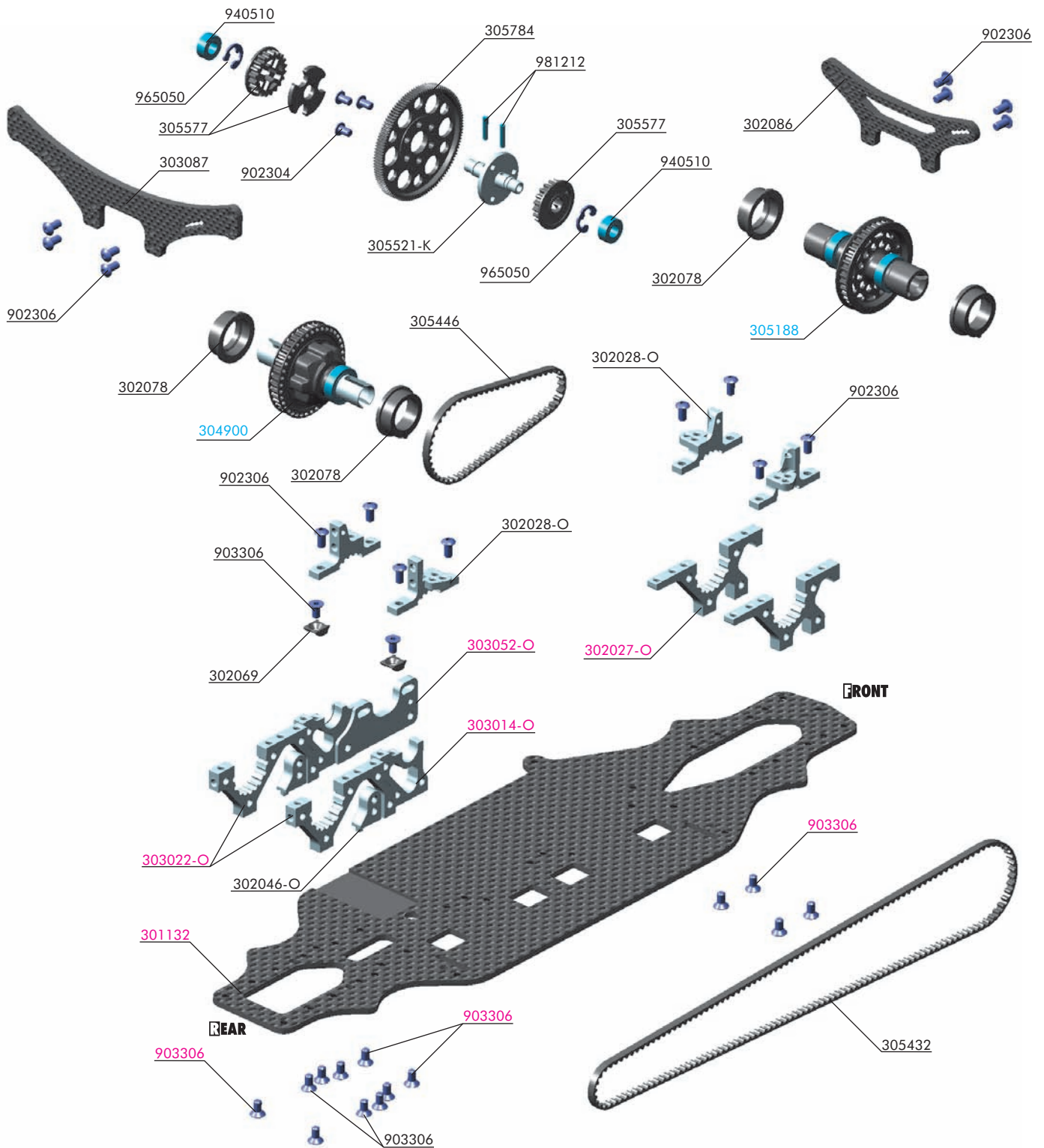

BAG

02

30 2028-O T3 ALU UPPER CLAMP WITH ADJ. ROLL-CENTER (L+R) - ORANGE
 30 2046-O T3 ALU LOWER SUSPENSION HOLDER - ORANGE
 30 2069 T3 COMPOSITE LAYSHAFT BEARING SUPPORT SHIM (2)
 30 2077 SET OF COMPOSITE HUBS +1MM FOR BULKHEADS (4+2) (OPTION)
 30 2078 SET OF COMPOSITE HUBS FOR BULKHEADS (4+2)
 30 2086 T3'12 SHOCK TOWER FRONT - GRAPHITE 3.0MM
 30 3087 T3'12 SHOCK TOWER REAR 3.0MM GRAPHITE
 30 5432 HIGH-PERFORMANCE KEVLAR DRIVE BELT FRONT 3 x 513 MM
 30 5446 HIGH-PERFORMANCE KEVLAR DRIVE BELT REAR 3 x 189 MM
 30 5521-K ALU SOLID LAYSHAFT - BLACK
 30 5577 COMPOSITE FIXED PULLEY 20T (2)
 30 5778 OFFSET SPUR GEAR 78T / 48 (OPTION)
 30 5781 OFFSET SPUR GEAR 81T / 48 (OPTION)
 30 5784 SPUR GEAR 84T / 48
 30 5787 SPUR GEAR 87T / 48 (OPTION)
 30 5862 OFFSET SPUR GEAR 92T / 64 (OPTION)
 30 5866 OFFSET SPUR GEAR 96T / 64 (OPTION)
 30 5870 OFFSET SPUR GEAR 100T / 64 (OPTION)
 30 5874 OFFSET SPUR GEAR 104T / 64 (OPTION)
 30 5876 OFFSET SPUR GEAR 106T / 64 (OPTION)
 30 5878 OFFSET SPUR GEAR 108T / 64 (OPTION)
 30 5880 OFFSET SPUR GEAR 110T / 64 (OPTION)

30 5882 OFFSET SPUR GEAR 112T / 64 (OPTION)
 30 5884 OFFSET SPUR GEAR 114T / 64 (OPTION)
 30 5886 OFFSET SPUR GEAR 116T / 64 (OPTION)
 30 5888 OFFSET SPUR GEAR 118T / 64 (OPTION)

90 2304 HEX SCREW SH M3x4 - STAINLESS (10)
 90 2306 HEX SCREW SH M3x6 (10)
 90 3306 HEX SCREW SFH M3x6 (10)
 94 0510 HIGH-SPEED BALL-BEARING 5x10x4 RUBBER SEALED (2)
 96 5050 E-CLIP 5 (10)
 98 1212 PIN 2x12 (10)

30 4900 XRAY GEAR DIFFERENTIAL - SET
 30 5188 COMPOSITE SOLID AXLE 38T - SET

30 1132 T3'12 CHASSIS 2.5MM GRAPHITE
 30 2027-O T3 ALU FRONT LOWER SUSP. ADJUST. BULKHEAD - ORANGE
 30 3014-O T3 ALU RIGHT LAYSHAFT BULKHEAD - ORANGE
 30 3022-O T3 ALU REAR LOWER SUSP. ADJUST. BULKHEAD - ORANGE
 30 3052-O T3 ALU MOTOR MOUNT BULKHEAD - ORANGE
 90 3306 HEX SCREW SFH M3x6 (10)

2. CENTRAL TRANSMISSION



903306
SFH M3x6



When tightening the screws, push the alu holders gently against screw tightening direction.



OPTIONAL FINE ROLL-CENTER ADJUSTMENT

Optional shims may be used for raising roll center. Use 3x7 shims with thicknesses between 0.1-0.5mm



The rear aluminum holders have integrated rear toe-in (approximately 1° rear toe-in).

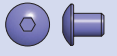
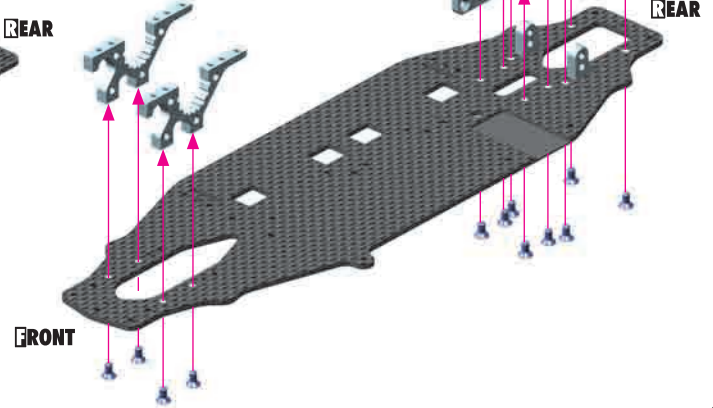

902304
SH M3x4



965050
CS



981212
P 2x12

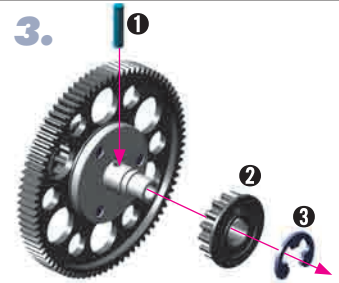
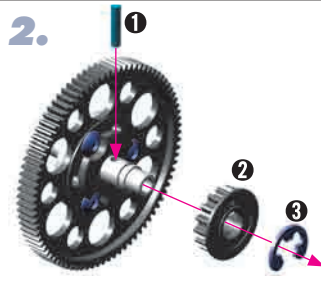
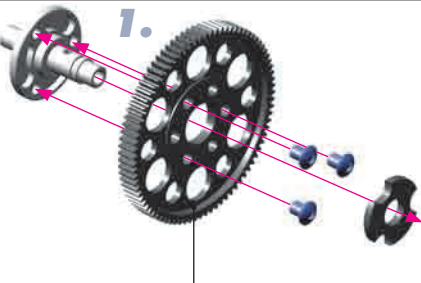

NOTE ORIENTATION
Only when using XRAY
OFFSET spur gears



SPUR GEARS 48P

#305778	OFFSET SPUR GEAR 78T / 48P
#305781	OFFSET SPUR GEAR 81T / 48P
#305784	SPUR GEAR 84T / 48P
#305787	SPUR GEAR 87T / 48P

SPUR GEARS 64P

#305862	OFFSET SPUR GEAR 92T / 64P
#305866	OFFSET SPUR GEAR 96T / 64P
#305870	OFFSET SPUR GEAR 100T / 64P
#305874	OFFSET SPUR GEAR 104T / 64P
#305876	OFFSET SPUR GEAR 106T / 64P
#305878	OFFSET SPUR GEAR 108T / 64P
#305880	OFFSET SPUR GEAR 110T / 64P
#305882	OFFSET SPUR GEAR 112T / 64P
#305884	OFFSET SPUR GEAR 114T / 64P
#305886	OFFSET SPUR GEAR 116T / 64P
#305888	OFFSET SPUR GEAR 118T / 64P



GEARING ADJUSTMENT



940510
BB 5x10x4

NOTE ORIENTATION

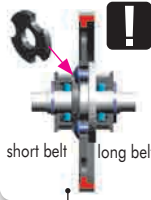

BEARING OIL
(HUDY #106230)



BEARING OIL
(HUDY #106230)

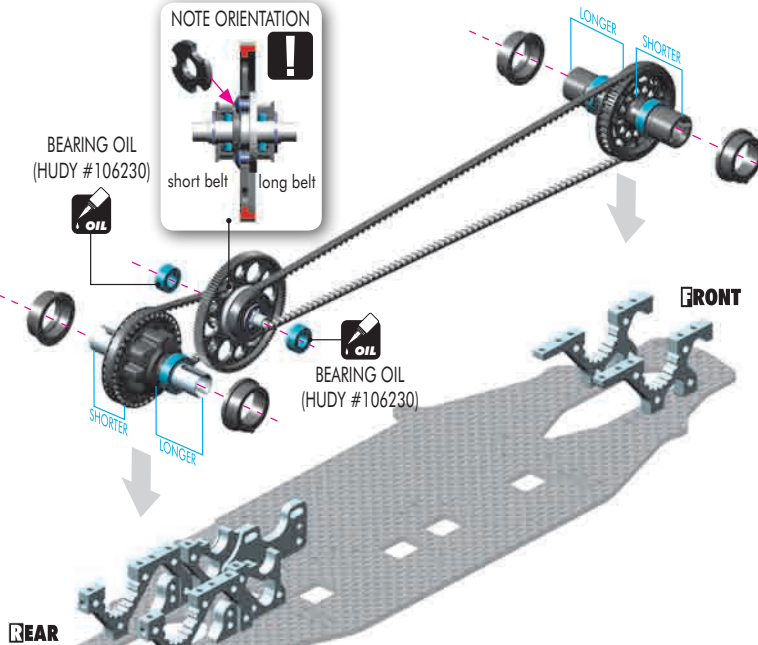

2. CENTRAL TRANSMISSION

FRONT BELT TENSION ADJUSTMENT

Front diff upper position is recommended for tight and technical carpet tracks. The upper diff position improves handling in chicanes as it provides more traction, increased steering and makes the car easier to drive.

Front diff lower position is recommended for large open asphalt tracks with long sweepers.

FRONT

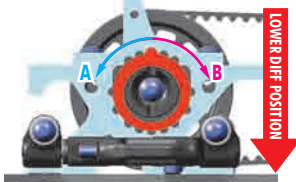
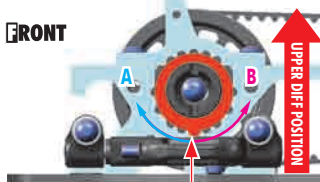

INITIAL POSITION

PLACE TAB IN THIS BOTTOM NOTCH

TO LOOSEN FRONT BELT: Rotate both front nylon hubs in arrow direction (A)

TO TIGHTEN FRONT BELT: Rotate both front nylon hubs in arrow direction (B)

REAR BELT TENSION ADJUSTMENT

Rear diff upper position is recommended for tight and technical carpet tracks. The upper diff position improves handling in chicanes as it provides more traction, increased steering and makes the car easier to drive.

Rear diff lower position is recommended for large open asphalt tracks with long sweepers.

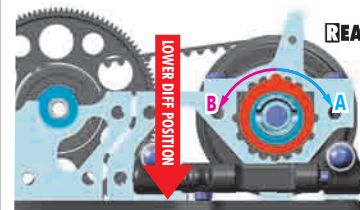
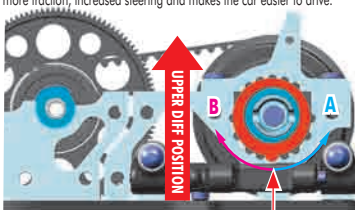

INITIAL POSITION

PLACE TAB IN THIS BOTTOM NOTCH

TO LOOSEN REAR BELT: Rotate both rear nylon hubs in arrow direction (A)

TO TIGHTEN REAR BELT: Rotate both rear nylon hubs in arrow direction (B)



OPTIONAL:
#303071 Belt Tensioner may be used when the front belt becomes worn and loose.

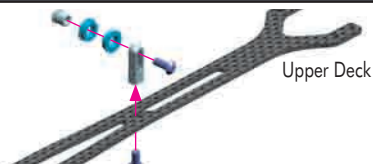

Upper Deck



DETAIL



903306
SFH M3x6

2x

NOTE ORIENTATION

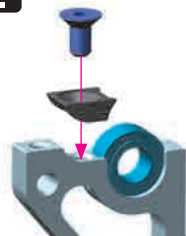

IMPORTANT!

Tighten the M3x6 screws carefully so the ball-bearing will move freely but without play.



REAR



902306
SFH M3x6

L=R

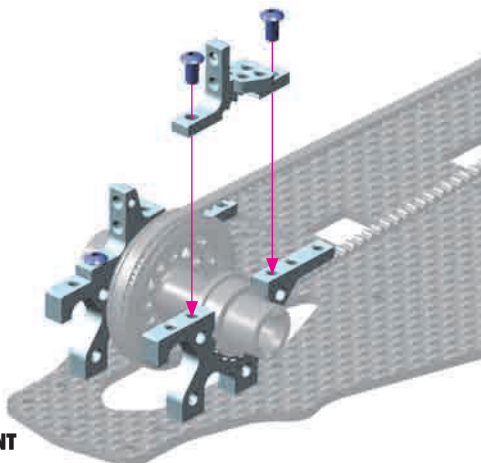

FRONT

L=R

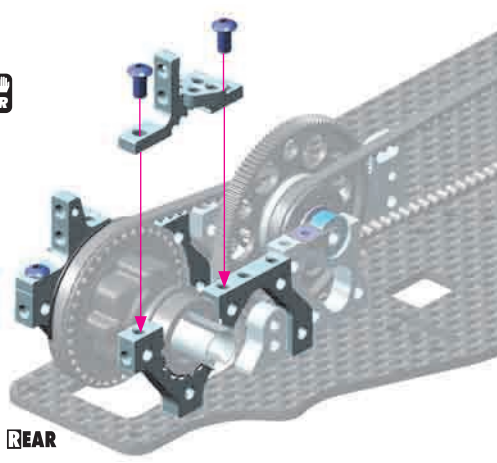

REAR



902306
SFH M3x6

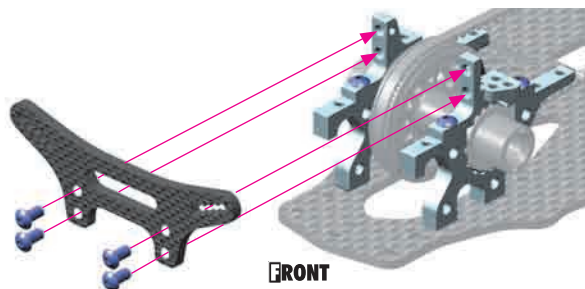

FRONT

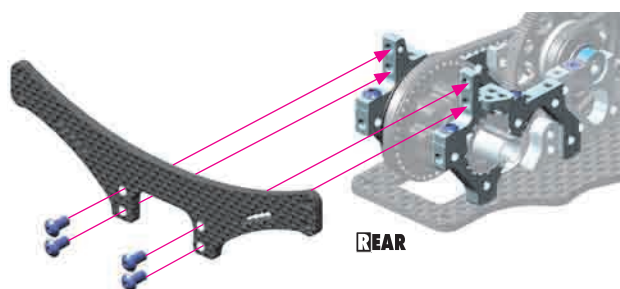

REAR

3. FRONT & REAR SUSPENSION

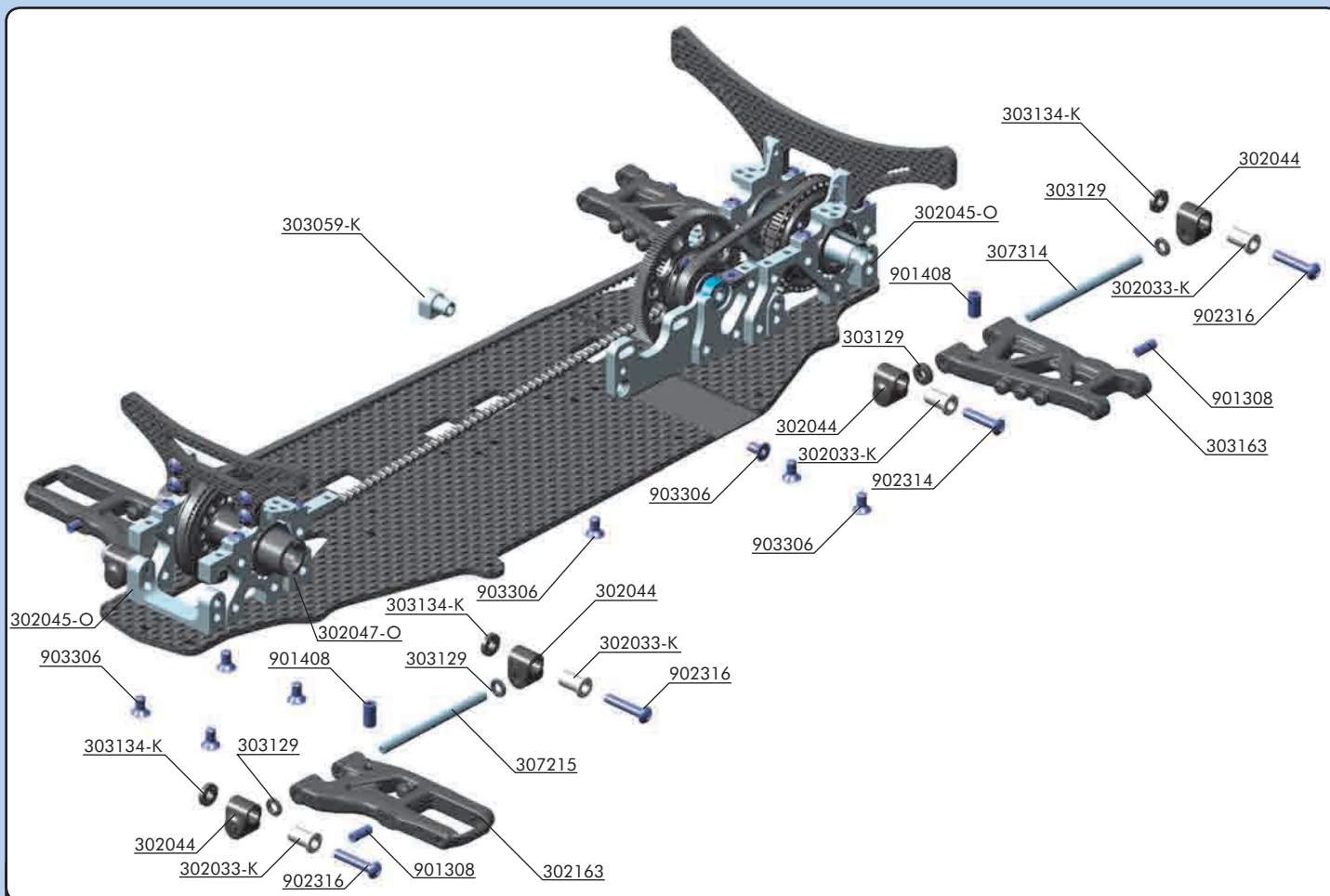

BAG

03

- 30 2033-K ALU NUT FOR SUSPENSION HOLDER - BLACK (2)
- 30 2044 LOWER SUSPENSION HOLDERS (2+2+2)
- 30 2045-O T3 ALU LOWER SUSPENSION BLOCK - ORANGE
- 30 2047-O T3 ALU LOWER FRONT SUSPENSION 1-PIECE HOLDER - ORANGE
- 30 2163 FRONT SUSPENSION ARM - HARD - 1-HOLE
- 30 2164 FRONT SUSPENSION ARM - EXTRA-HARD - 1-HOLE (OPTION)
- 30 3059-K T3 MOTOR BULKHEAD HOLDER - BLACK
- 30 3129 COMPOSITE SET OF WHEELBASE SHIMS (3x1MM; 1x2MM) (2)
- 30 3134-K ALU SHIM FOR LOWER SUSP. HOLDER 3x7.5x1.5 - BLACK (10)
- 30 3163 REAR SUSPENSION ARM - HARD - 1-HOLE - V2
- 30 3164 REAR SUSPENSION ARM - EXTRA-HARD - 1-HOLE - V2 (OPTION)
- 30 7215 T2 FRONT SUSPENSION PIVOT PIN (2)
- 30 7314 T2'008 REAR SUSPENSION PIVOT PIN (2)

- 90 1308 HEX SCREW SB M3x8 (10)
- 90 1408 HEX SCREW SB M4x8 (10)
- 90 2314 HEX SCREW SH M3x14 (10)
- 90 2316 HEX SCREW SH M3x16 (10)
- 90 3306 HEX SCREW SFH M3x6 (10)



903306
SFH M3x6

OPTIONAL FINE ROLL-CENTER ADJUSTMENT

Optional shims may be used for raising roll center. Use 3x7 shims with thicknesses between 0.1-0.5mm

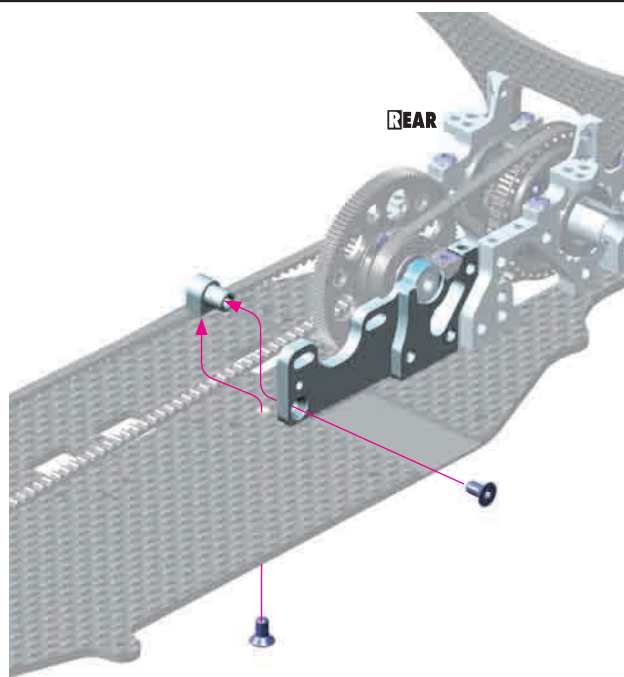
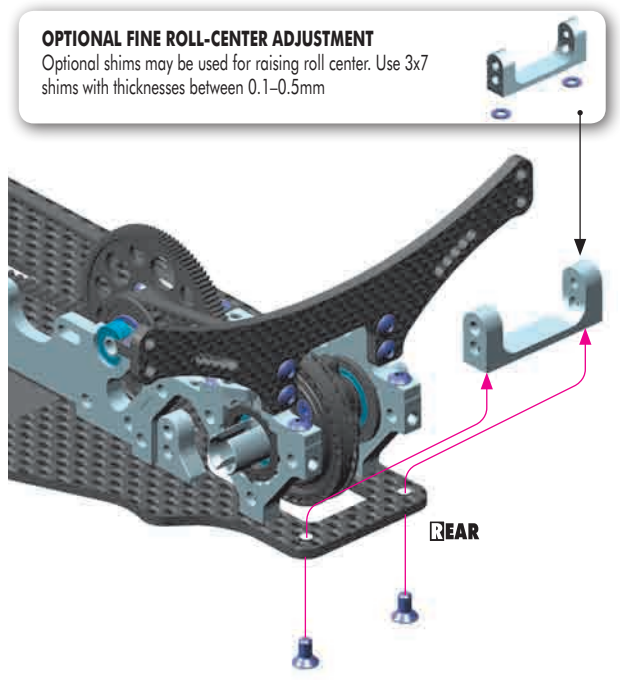

3. FRONT & REAR SUSPENSION



903306
SFH M3x6

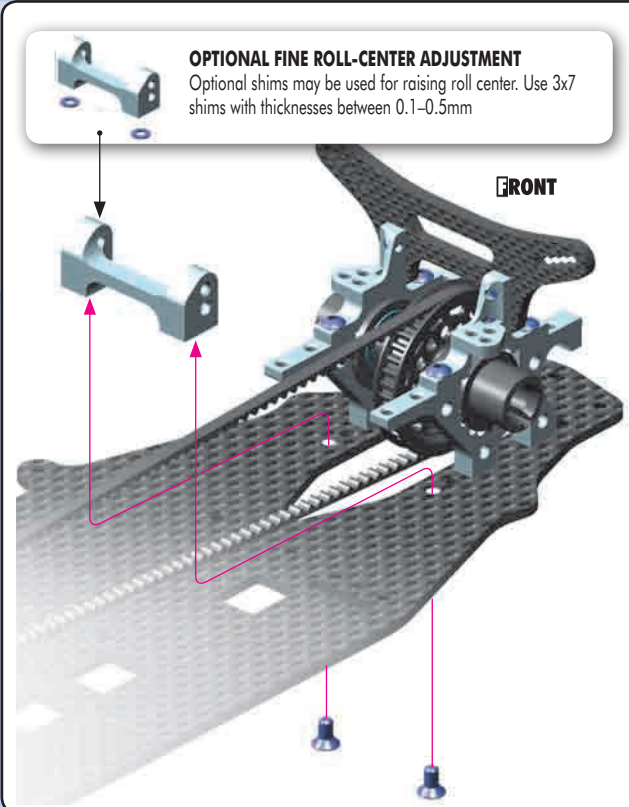

OPTIONAL FINE ROLL-CENTER ADJUSTMENT

Optional shims may be used for raising roll center. Use 3x7 shims with thicknesses between 0.1-0.5mm



OPTIONAL FINE ROLL-CENTER ADJUSTMENT

Optional shims may be used for raising roll center. Use 3x7 shims with thicknesses between 0.1-0.5mm

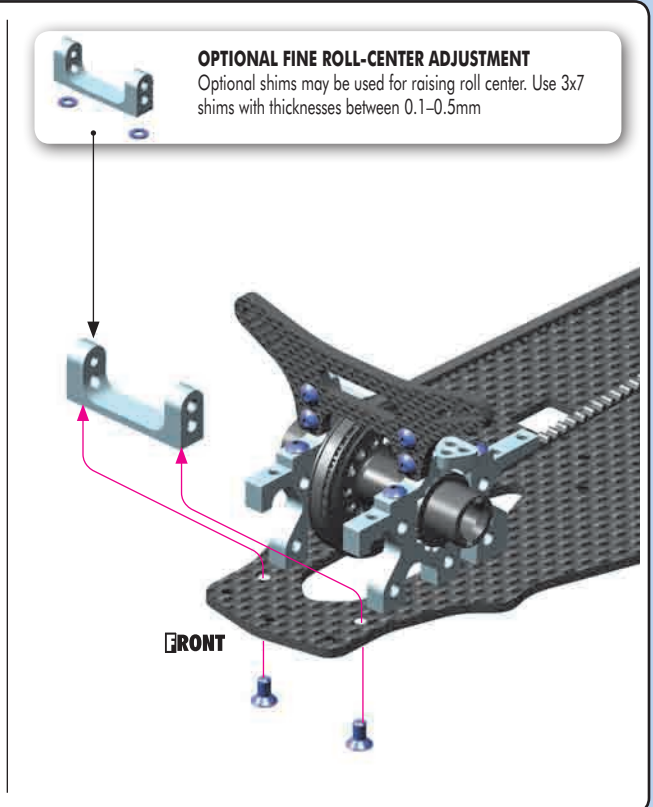

901308
SB M3x8



901408
SB M4x8



REAR ARMS

REAR LEFT ARM

REAR RIGHT ARM

TOP

BOTTOM

OPTIONAL 2-HOLE REAR ARMS

Inner position - more rear traction
Outer position - more stable
Use the inner position for initial setting.

OPTIONAL REAR ARMS - 2-HOLE

#303165	HARD (H)
#303166	EXTRA-HARD (XH)

REAR ARMS

#303163	HARD (H)
#303164	EXTRA-HARD (XH)

HARD ARM - more rear traction (recommended for low-, medium-traction)
EXTRA HARD ARM - more steering (recommended for high-traction)



REAR DOWNSTOP
ADJUSTMENT
REAR ANTI-ROLL BAR



901308
SB M3x8



901408
SB M4x8

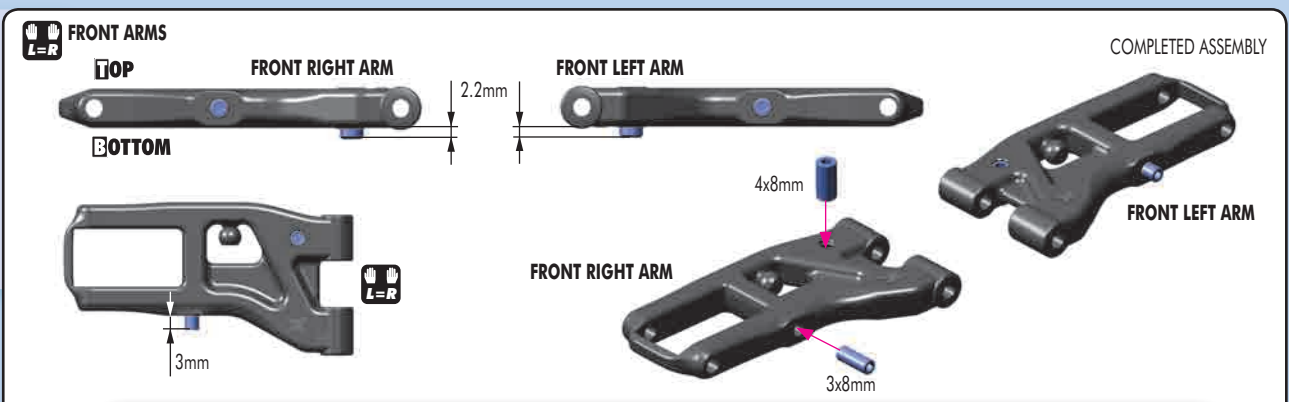

FRONT ARMS

TOP

FRONT RIGHT ARM

FRONT LEFT ARM

COMPLETED ASSEMBLY

BOTTOM

FRONT LEFT ARM

FRONT ARMS

#302163	HARD (H)
#302164	EXTRA-HARD (XH)

OPTIONAL FRONT ARMS - 2-HOLE

#302165	HARD (H)
#302166	EXTRA-HARD (XH)

OPTIONAL 2-HOLE FRONT ARMS

inner position - more steering
outer position - more stable
Use the outer position for initial setting.

HARD ARM - more steering (recommended for low-, medium-traction)
EXTRA HARD ARM - more stable, easier to drive (recommended for high-traction)



FRONT DOWNSTOP
ADJUSTMENT
FRONT ANTI-ROLL BAR

3. FRONT & REAR SUSPENSION

IO
303129
SHIM 3x6x1

IO
303129
SHIM 3x6x2

IO
303134-K
SHIM 3x7.5x1.5



902314
SH M3x14



902316
SH M3x16

L=R

It is extremely important that the arms move freely on the pivot pins. If they do not, use the #107633 HUDY Arm Reamer to slightly resize the holes in the arms.

REAR

THICK ALU SHIM 3 x 7.5 x 1.5mm

THIN COMPOSITE SHIM 3x6x1mm

THICK COMPOSITE SHIM 3x6x2mm

REAR LEFT ARM

3x16mm

3x14mm

DETAIL

Use these suspension holders for initial assembly

50.5 mm

2x 1:1

Roll Center Position: **-0.75mm**
(more traction, more on-power push)

Roll Center Position: **0mm**

Roll Center Position: **+0.75mm**
(better cornering speed, less traction)

SET-UP BOOK

TOE-IN ADJUSTMENT
TRACK-WIDTH ADJUSTMENT
WHEELBASE ADJUSTMENT
ROLL CENTER ADJUSTMENT
SQUAT ADJUSTMENT

IO
303129
SHIM 3x6x1

IO
303134-K
SHIM 3x7.5x1.5



902316
SH M3x16

L=R

It is extremely important that the arms move freely on the pivot pins. If they do not, use the #107633 HUDY Arm Reamer to slightly resize the holes in the arms.

FRONT LEFT ARM

FRONT

DETAIL

0mm

THICK ALU SHIM 3 x 7.5 x 1.5mm

THIN COMPOSITE SHIM 3x6x1mm

THIN COMPOSITE SHIM 3x6x1mm

FRONT RIGHT ARM

THICK ALU SHIM 3 x 7.5 x 1.5mm

3x16mm

DETAIL

0mm

Use these suspension holders for initial assembly

47.5 mm

2x L=R

Roll Center Position: **-0.75mm**
(more incorner steering, can cause tire overheating)

Roll Center Position: **0mm**

Roll Center Position: **+0.75mm**
(less in-corner steering, easier to drive)

SET-UP BOOK

TOE-IN ADJUSTMENT
TRACK-WIDTH ADJUSTMENT
WHEELBASE ADJUSTMENT
ROLL CENTER ADJUSTMENT
SQUAT ADJUSTMENT

4. STEERING

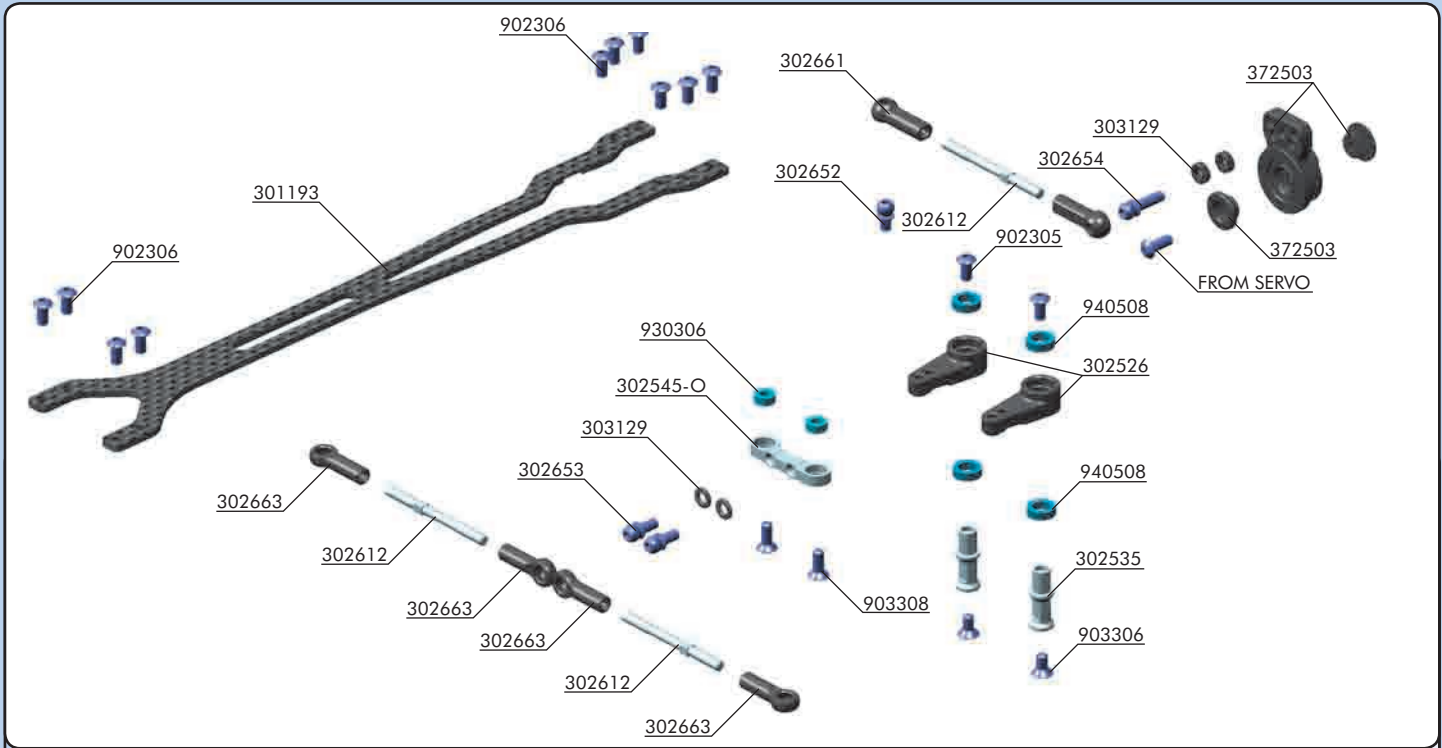

BAG

04

- | | | | |
|-----------|---|---------|---|
| 30 1193 | T3'12 UPPER DECK 2.0MM GRAPHITE | 30 2661 | COMPOSITE BALL JOINT 4.9MM - CLOSED (4) |
| 30 2506 | XRAY DUAL SERVO SAVER SET | 30 2663 | COMPOSITE BALL JOINT 5 MM - OPEN - V2 (8) |
| 30 2526 | COMPOSITE DUAL SERVO SAVER ARM | 30 3129 | COMPOSITE SET OF SHIMS (3x1MM; 1x2MM) (2) |
| 30 2535 | ALU STEERING POST FOR DUAL SERVO SAVER (2) | 37 2503 | COMPOSITE SERVO SAVER - X-STIFF - SET |
| 30 2545-O | ALU STEERING PLATE FOR DUAL SERVO SAVER - ORANGE | 90 2305 | HEX SCREW SH M3x5 (10) |
| 30 2610 | ADJ. TURNBUCKLE M3 L/R 40 MM - HUDY SPRING STEEL™(2) (OPTION) | 90 2306 | HEX SCREW SH M3x6 (10) |
| 30 2612 | ALU ADJ. TURNBUCKLE M3 L/R 39 MM - SWISS 7075 T6 (2) | 90 3306 | HEX SCREW SFH M3x6 (10) |
| 30 2652 | BALL END 5 MM WITH THREAD 4MM (2) | 90 3308 | HEX SCREW SFH M3x8 (10) |
| 30 2653 | BALL END 4.9MM WITH THREAD 6MM (2) | 93 0306 | BALL-BEARING 3x6x2.5 (2) |
| 30 2654 | BALL END 4.9MM WITH THREAD 8MM (2) | 94 0508 | HIGH-SPEED BALL-BEARING 5x8x2.5 RUBBER SEALED (2) |

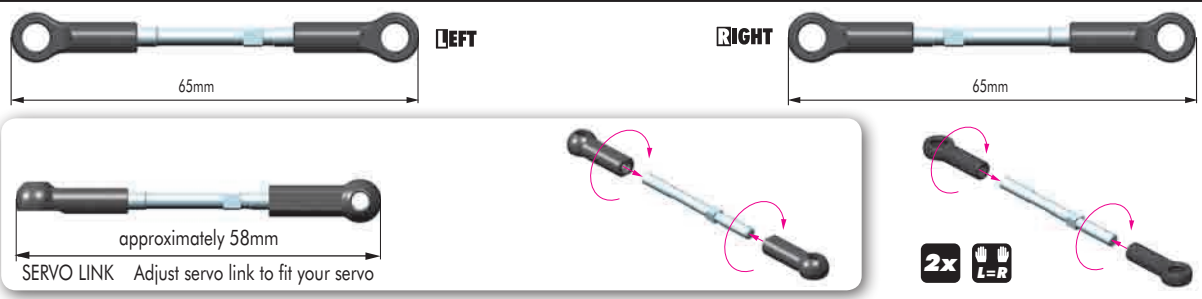

SET-UP BOOK

FRONT TOE-IN ADJUSTMENT

- 303129 SHIM 3x6x1
- 903308 SFH M3x8
- 930306 BB 3x6
- 940508 BB 5x8

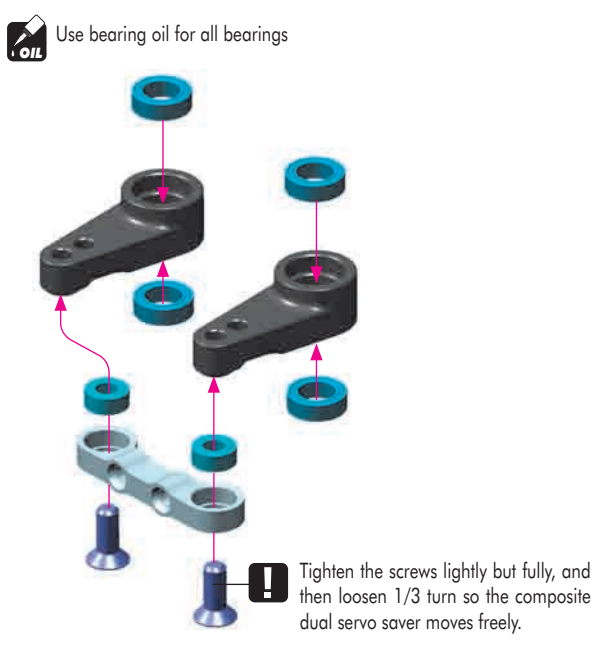

TIP

To change Ackermann angle, use 2 identical shims (of same thickness) between the alu steering plate and ball end.

3x1mm & 1x2mm composite shims

4. STEERING

10

303129
SHIM 3x6x2

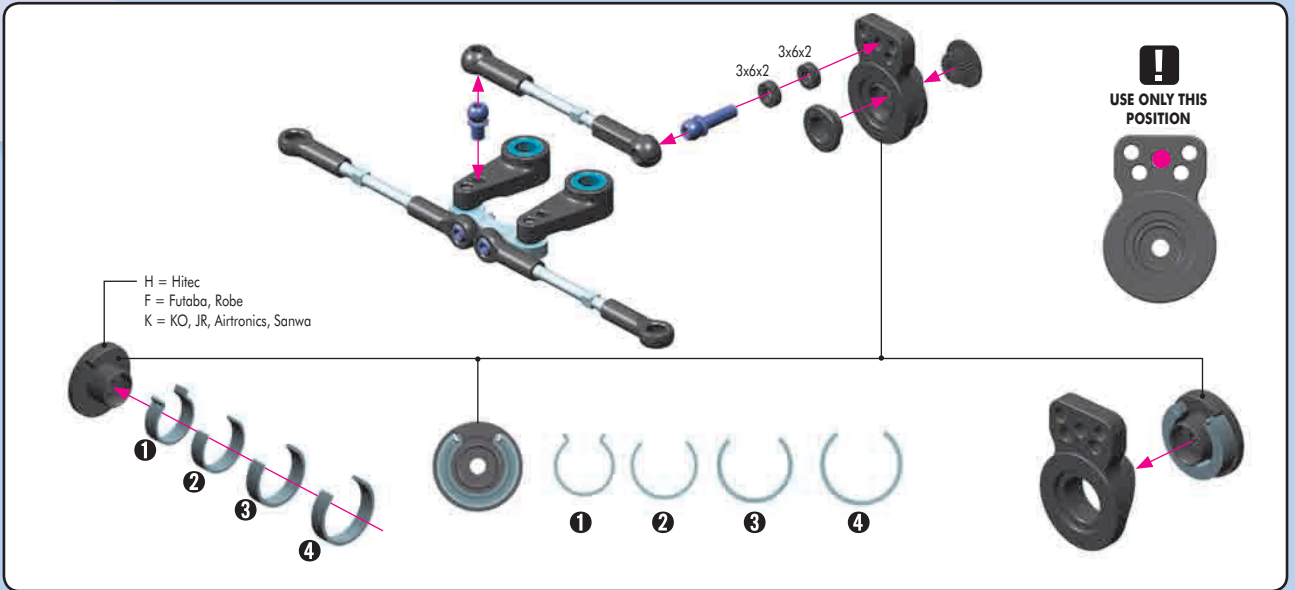

902305
SH M3x5

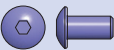
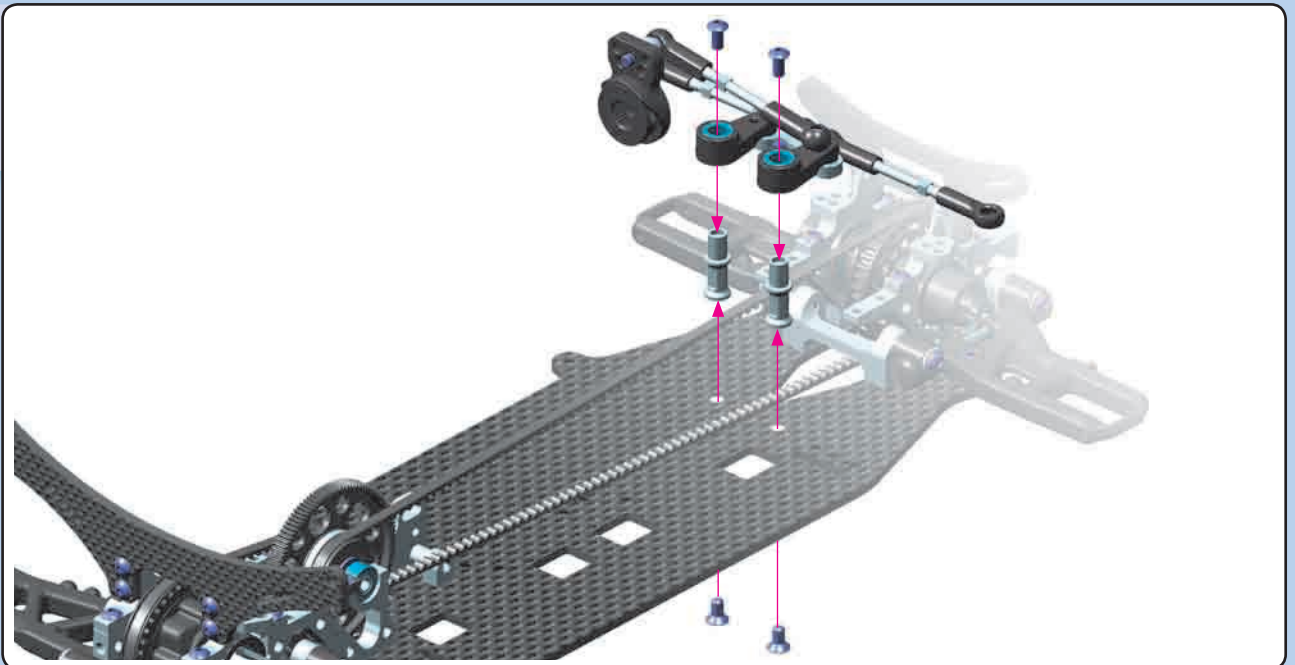

902306
SH M3x6

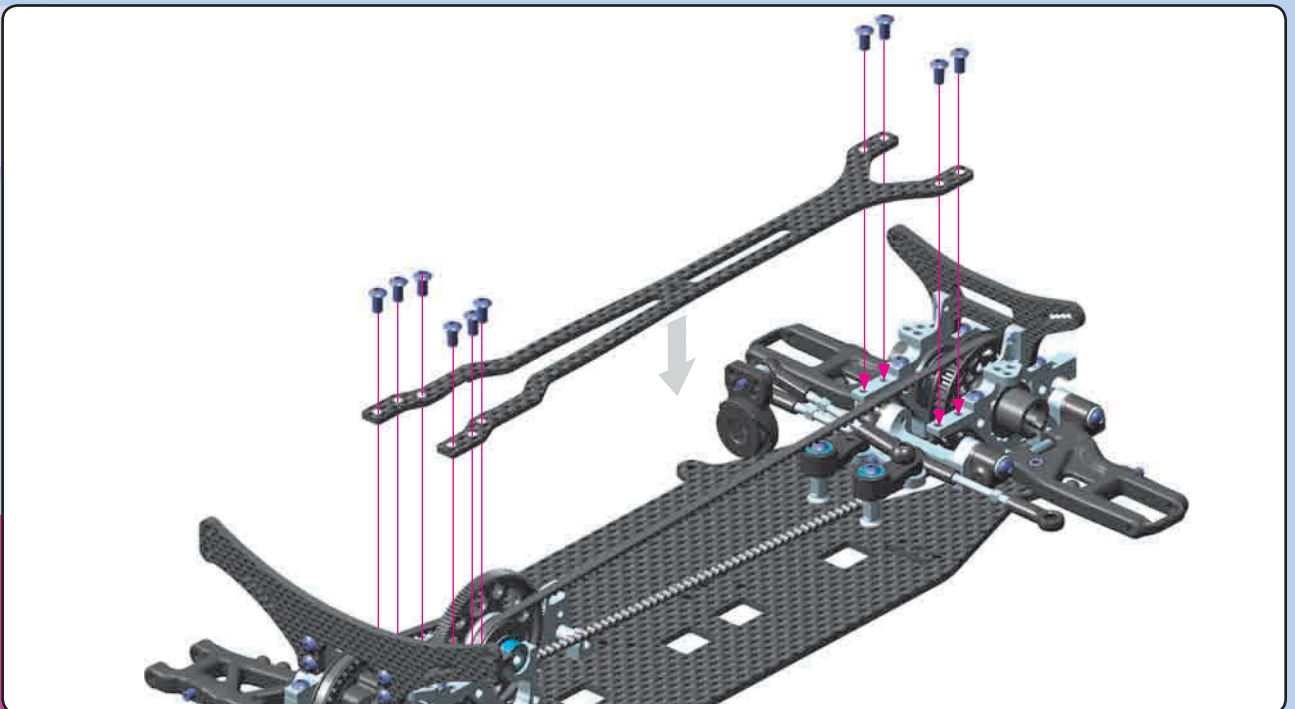

ACKERMANN ADJUSTMENT
STEERING THROW SYMMETRY
CHASSIS FLEX SETTING
TOP DECK FLEX SETTING

5. FRONT & REAR TRANSMISSION

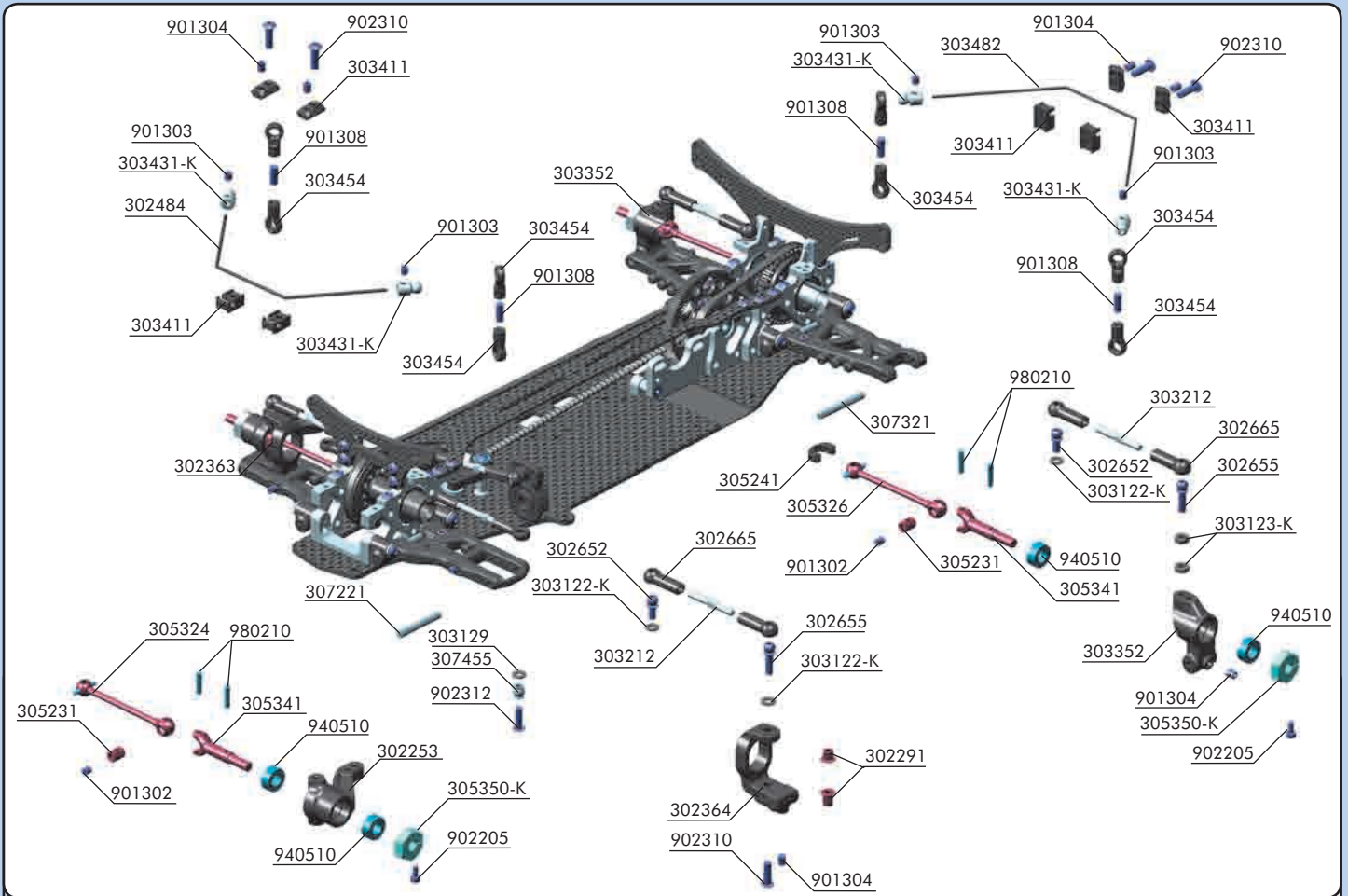

BAG

05

- | | | |
|--|--|--|
| <p>30 2252 COMPOSITE STEERING BLOCK - MEDIUM - V2 (OPTION)
 30 2253 COMPOSITE STEERING BLOCK - HARD
 30 2291 STEEL STEERING BUSHING (2+2)
 30 2363 COMPOSITE C-HUB RIGHT - 4° DEG. - MEDIUM
 30 2364 COMPOSITE C-HUB LEFT - 4° DEG. - MEDIUM
 30 2373 COMPOSITE C-HUB RIGHT - 4° DEG. - HARD (OPTION)
 30 2374 COMPOSITE C-HUB LEFT - 4° DEG. - HARD (OPTION)
 30 2484 ANTI-ROLL BAR FRONT 1.4 MM
 30 2652 BALL END 4.9MM WITH THREAD 4MM (2)
 30 2655 BALL END 4.9MM WITH THREAD 10MM (2)
 30 2665 COMPOSITE BALL JOINT 4.9MM - CLOSED WITH HOLE (4)
 30 3122-K ALU SHIM 3x6x1.0MM - BLACK (10)
 30 3123-K ALU SHIM 3x6x2.0MM - BLACK (10)
 30 3129 COMPOSITE SET OF SHIMS (3x1MM; 1x2MM) (2)
 30 3210 TURNBUCKLE M3 L/R 26 MM - SPRING STEEL™ (2) (OPTION)
 30 3212 ALU ADJ. TURNBUCKLE M3 L/R 26 MM - SWISS 7075 T6 (2)
 30 3352 UPRIGHT 0° OUTBOARD TOE-IN - MEDIUM
 30 3353 UPRIGHT 1° OUTBOARD TOE-IN - RIGHT - HARD (OPTION)
 30 3363 UPRIGHT 1° OUTBOARD TOE-IN - LEFT - HARD (OPTION)
 30 3411 COMPOSITE ANTI-ROLL BAR HOLDERS - V2
 30 3431-K ALU 5 MM BALL END - BLACK (2)
 30 3454 BALL JOINT 5 MM - OPEN (4)
 30 3482 ANTI-ROLL BAR REAR 1.2 MM</p> | <p>30 5231 DRIVE SHAFT COUPLING - HUDY SPRING STEEL™
 30 5241 DRIVE SHAFT REPLACEMENT PLASTIC CAP 3.5 MM (4)
 30 5323 DRIVE SHAFT 50MM - HUDY SPRING STEEL™ (OPTION)
 30 5324 DRIVE SHAFT 52MM - HUDY SPRING STEEL™
 30 5325 EQUALIZED CORNERING SPEED (ECS) DRIVE SHAFT 50MM (OPTION)
 30 5326 ALU DRIVE SHAFT SWISS 7075 T6 - HARD COATED - 52MM
 30 5327 EQUALIZED CORNERING SPEED (ECS) DRIVE SHAFT 52MM (OPTION)
 30 5328 ALU DRIVE SHAFT SWISS 7075 T6 - HARD COATED - 50MM (OPTION)
 30 5341 DRIVE AXLE - LIGHTWEIGHT - HUDY SPRING STEEL™
 30 5350-K ALU WHEEL HUB - BLACK (2)
 30 7221 FRONT ARM PIVOT PIN (2)
 30 7321 REAR ARM PIVOT PIN (2)
 30 7455 PIVOT BALL 4.9 MM DOUBLE BEVEL SHOULDERS (10)</p> | <p>90 1302 HEX SCREW SB M3x2.5 (10)
 90 1303 HEX SCREW SB M3x3 (10)
 90 1304 HEX SCREW SB M3x4 (10)
 90 1308 HEX SCREW SB M3x8 (10)
 90 2205 HEX SCREW SH M2x5 (10)
 90 2310 HEX SCREW SH M3x10 (10)
 90 2312 HEX SCREW SH M3x12 (10)
 94 0510 HIGH-SPEED BALL-BEARING 5x10x4 RUBBER SEALED (2)
 98 0210 PIN 2x10 (10)</p> |
|--|--|--|



901302
SB M3x2.5

980210
P 2x10

4x



For easy and comfortable installation of the #305241 plastic caps use pliers as shown.

OPTIONAL ECS DRIVE SHAFTS



ECS shafts are available optionally in both 50mm and 52mm lengths. The ECS drive shafts were developed to decrease front wheel vibration when racing with a solid front axle, thus providing a much smoother and quieter ride and increased steering.

NOTE: The rear gear differential is made to fit 52mm drive shafts when using more than 2.5° rear toe-in and less than 2° camber. If you want to use less than 2.5° toe-in and/or more than 2° camber (not recommended), you will need to remove a small amount of material from the front of the plastic cap to allow it to fit into the gear diff.

DRIVE SHAFTS

#305323	50MM - STEEL
#305324	52MM - STEEL
#305325	50MM - ECS
#305326	52MM - ALU
#305327	52MM - ECS
#305328	50MM - ALU

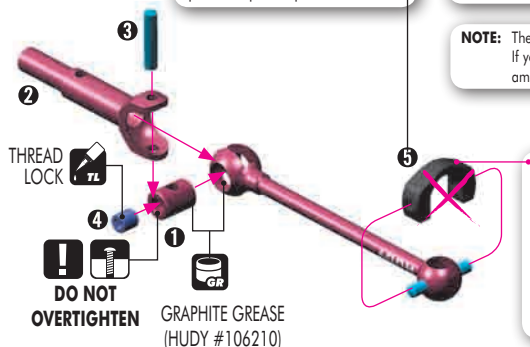

IMPORTANT!

DO NOT use the plastic caps with composite solid axle included in the kits.

The new #305241 3.5mm plastic caps are for use ONLY with GEAR diffs, ALU ball diffs, or the XRAY Multi-Diff™.

Longer drive shafts (52mm) make the car easier to drive because they give more traction and better stability, mainly in chicanes. However, the car will understeer more than with shorter (50mm) shafts which give a lot of steering and impart aggression to the car. You may also combine different lengths of shafts in front and rear (for example, using long shafts in the rear and short shafts in the front) depending on track conditions.

Both left & right shafts should ALWAYS be the same length at one end of the car (front or rear).

52mm shafts are recommended for carpet and big asphalt tracks
 50mm shafts are recommended for small-medium tight asphalt tracks

5. FRONT & REAR TRANSMISSION

902205
SH M2x5

940510
BB 5x10x4

980210
P 2x10

SET-UP BOOK

REAR TOE-IN ADJUSTMENT

2x !

0° OUTBOARD TOE-IN UPRIGHTS

L=R

LEFT UPRIGHT = RIGHT UPRIGHT

OIL BEARING OIL (HUDY #106230)

USE ALU DRIVE SHAFTS IN REAR !

COMPLETED ASSEMBLY

UPRIGHTS	
#303351	1° - R - MEDIUM - 2-HOLE
#303352	0° - R/L - MEDIUM - 2-HOLE
#303353	1° - R - HARD - 2-HOLE
#303354	0° - R/L - HARD - 2-HOLE
#303361	1° - L - MEDIUM - 2-HOLE
#303362	0° - R/L - MEDIUM - 1-HOLE
#303363	1° - L - HARD - 2-HOLE
#303364	0° - R/L - HARD - 1-HOLE
#303358	ALU 1° - R/L - 4-HOLE
#303359	ALU 2° - R/L - 4-HOLE

902205
SH M2x5

940510
BB 5x10x4

980210
P 2x10

SET-UP BOOK

REAR TOE-IN ADJUSTMENT

2x L=R

LEFT STEERING BLOCK = RIGHT STEERING BLOCK

OIL BEARING OIL (HUDY #106230)

USE STEEL DRIVE SHAFTS IN FRONT !

COMPLETED ASSEMBLY

STEERING BLOCKS	
#302252	MEDIUM
#302253	HARD
#302256	ALU

WHEEL HUBS	
#305350	ALU - OFFSET 0 MM
#305351	ALU - OFFSET -0.75 MM
#305352	ALU - OFFSET +0.75 MM
#305353	ALU - OFFSET +1.5 MM

902310
SH M3x10

SET-UP BOOK

CASTER ADJUSTMENT

2x

RIGHT C-HUB "4R"

RIGHT

SHORT

LONG

LEFT

COMPLETED ASSEMBLY

LEFT C-HUB "4L"

C-HUBS	
#302334	ALU 0° - R + L
#302335	ALU 2° - RIGHT
#302336	ALU 2° - LEFT
#302337	ALU 4° - RIGHT
#302338	ALU 4° - LEFT
#302339	ALU 6° - RIGHT
#302340	ALU 6° - LEFT
#302361	2° - RIGHT - MEDIUM
#302362	2° - LEFT - MEDIUM
#302363	4° - RIGHT - MEDIUM
#302364	4° - LEFT - MEDIUM
#302365	6° - RIGHT - MEDIUM
#302366	6° - LEFT - MEDIUM
#302371	2° - RIGHT - HARD
#302372	2° - LEFT - HARD
#302373	4° - RIGHT - HARD
#302374	4° - LEFT - HARD
#302375	6° - RIGHT - HARD
#302376	6° - LEFT - HARD

SET-UP BOOK

CAMBER ADJUSTMENT

4x L=R

FRONT RIGHT = FRONT LEFT

FRONT

Carpet: 57 mm
Asphalt: 55 mm

REAR RIGHT = REAR LEFT

REAR

Carpet: 56 mm
Asphalt: 54 mm

5. FRONT & REAR TRANSMISSION



303123-K
SHIM 3x6x2



901304
SB M3x4



LEFT UPRIGHT = RIGHT UPRIGHT



0° OUTBOARD TOE-IN UPRIGHTS

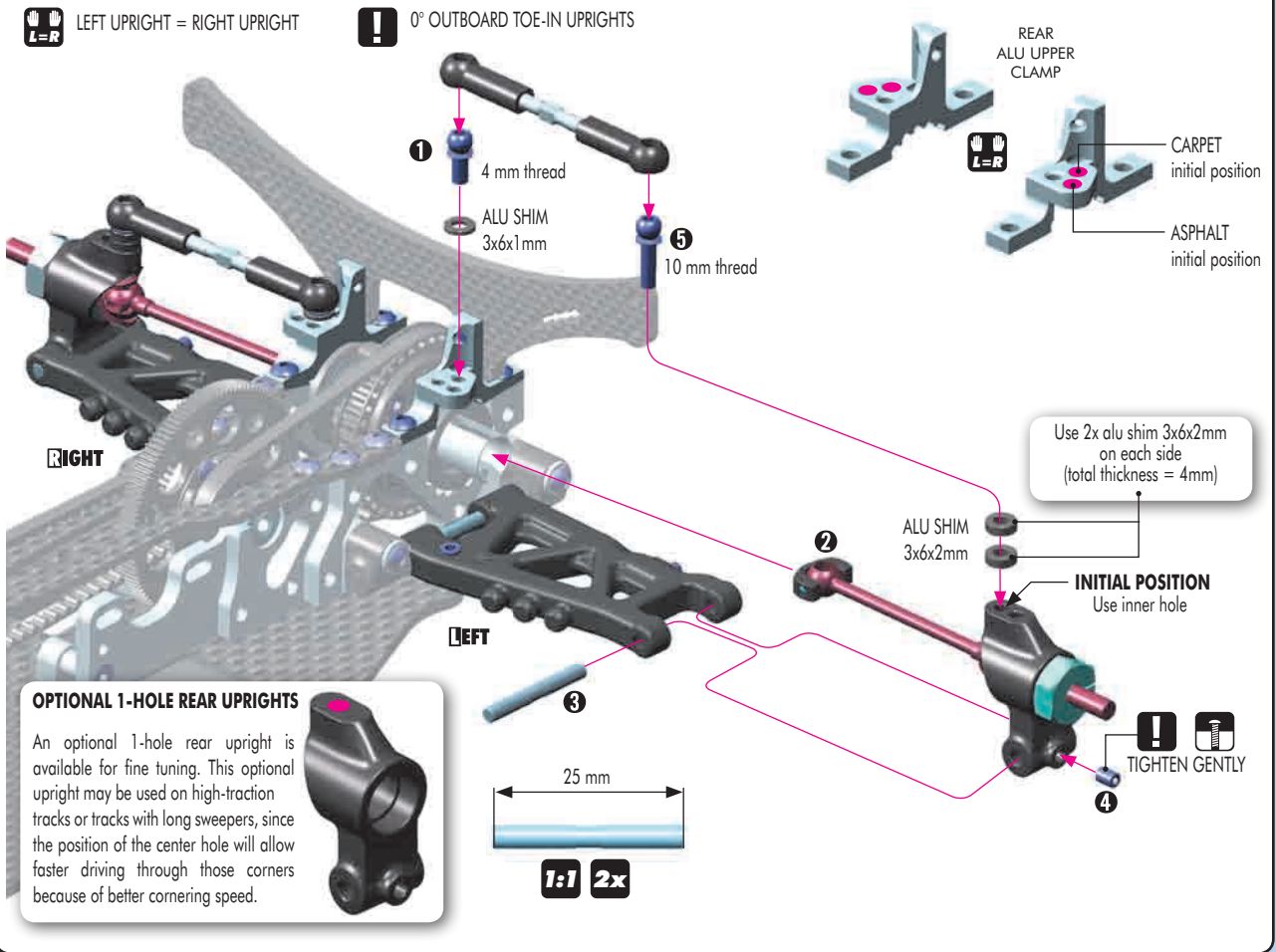

303122-K
SHIM 3x6x1



901304
SB M3x4

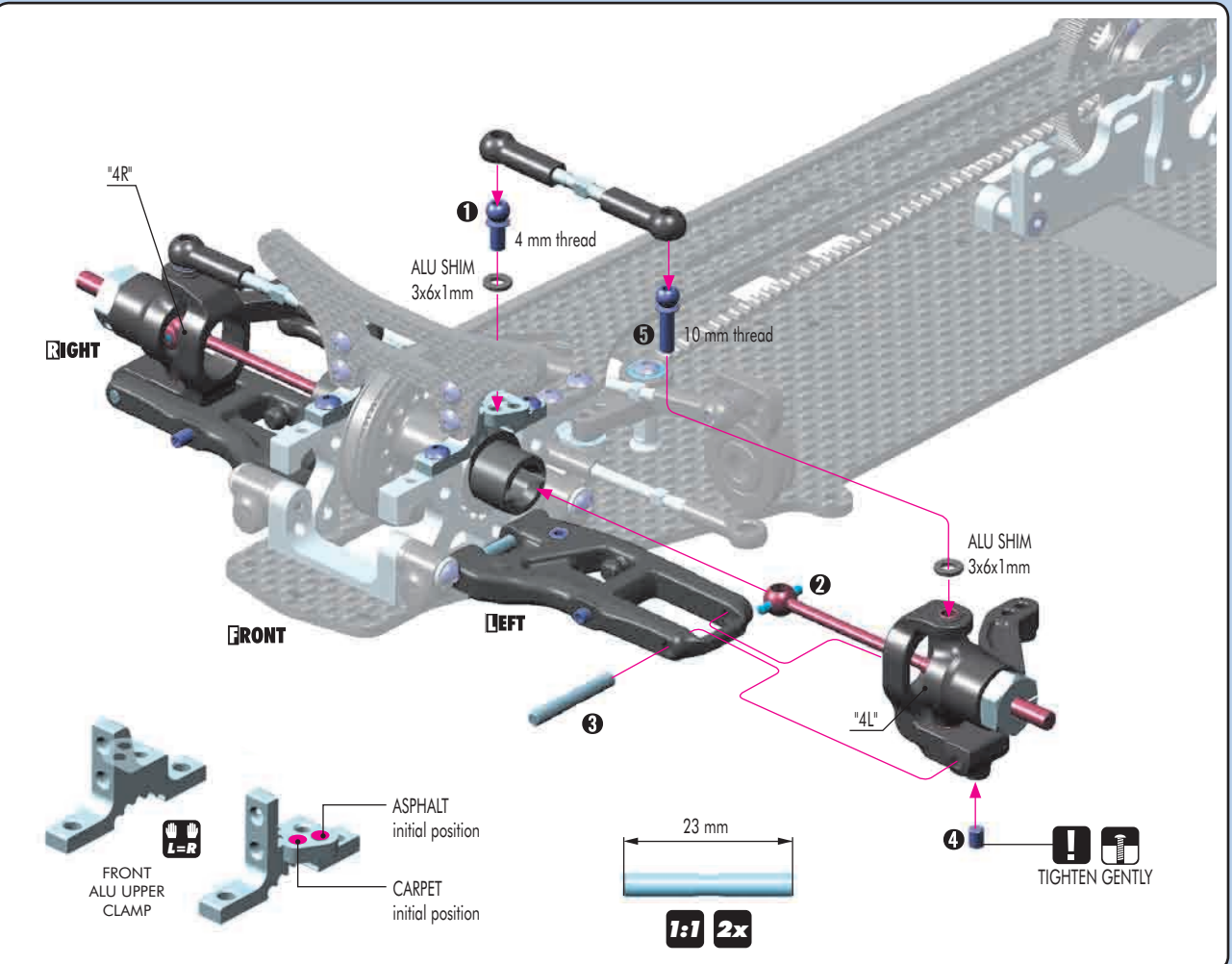

ROLL-CENTER ADJUSTMENT

5. FRONT & REAR TRANSMISSION



303129
SHIM 3x6x1



307455
PB 5mm



902312
SH M3x12



The number of shims changes the angles of the steering linkage. When no shims are used, the car is easy to drive into the corner. As the number of shims is increased, in-corner steering increases but the car becomes more difficult to drive.

FREE MOVEMENT

FRONT

FREE MOVEMENT

INITIAL POSITION



COMPOSITE SHIM
3x6x1mm



901308
SB M3x8

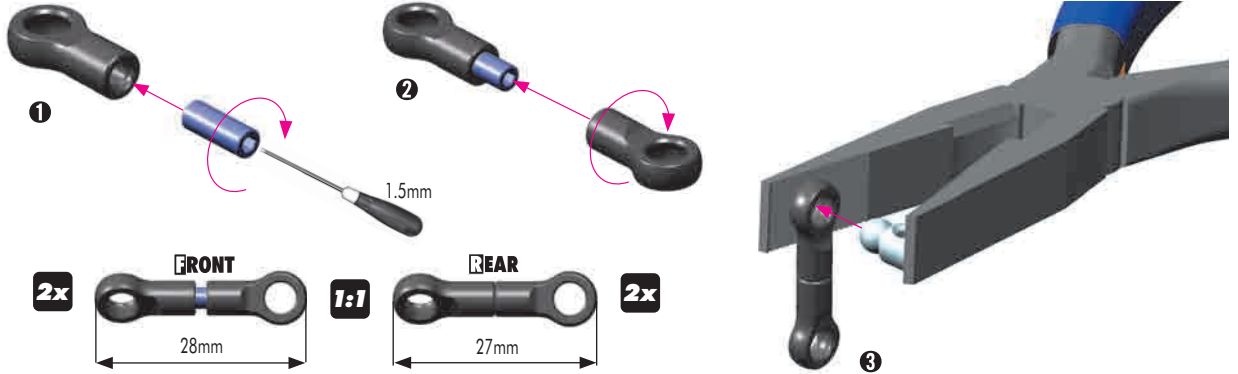

901303
SB M3x3

901304
SB M3x4



902310
SH M3x10

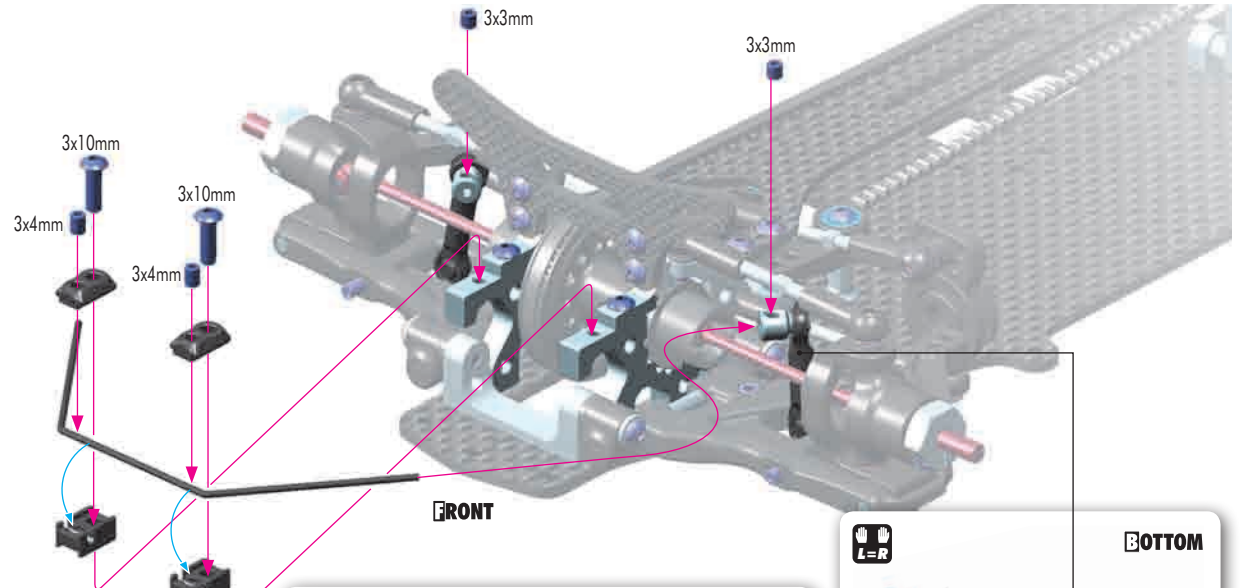

ASSEMBLY VIEW

Wire should be flush with end of pivot ball.

0mm

Only tighten enough to remove excessive free play; anti-roll bar must move freely.

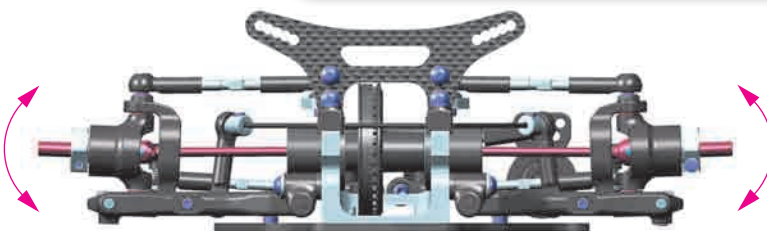
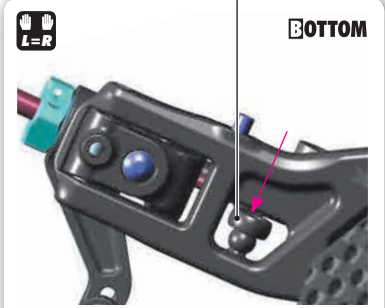

When the bars are set, verify that both sides move at the same time. If they do, the bars are set up correctly. If not, make sure that both downstops are the same and that the bar wire is flat.

5. FRONT & REAR TRANSMISSION



901303
SB M3x3



901304
SB M3x4



902310
SH M3x10

REAR ANTI-ROLL BAR

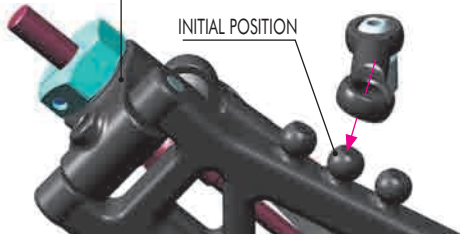
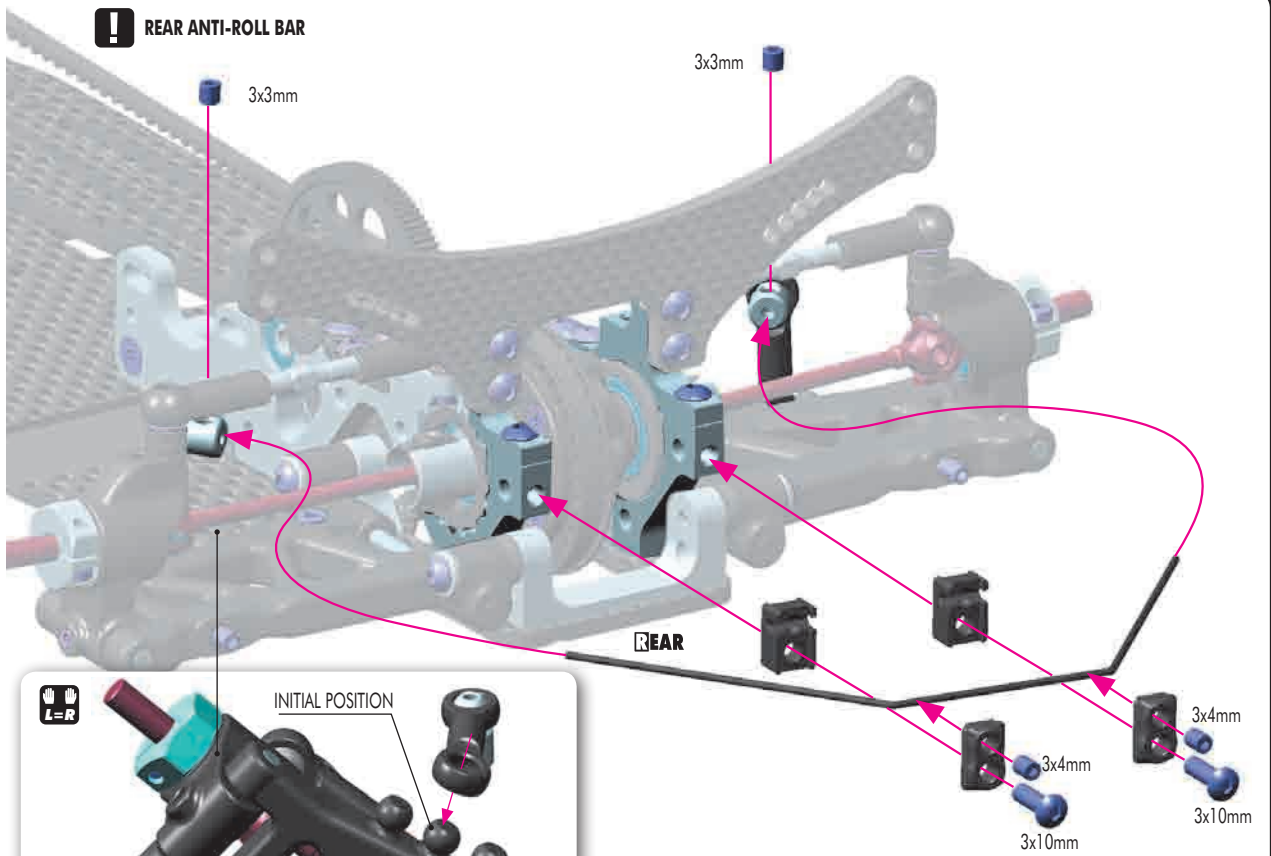

Initial position = **MIDDLE** ball

Use the **INNER** ball on low-traction tracks (mainly low-traction carpet tracks). The car will have more traction & more steering, but will be more difficult to drive because the car will roll more. Recommended on chicane tracks.

Use the **MIDDLE** ball on low- to medium-traction tracks (asphalt, carpet). The car will have a little less rear traction and the car will roll a little less which will make it easier to drive with more cornering speed.

Use the **OUTER** ball on high-traction tracks (mainly high-traction asphalt tracks). The car will roll even less which will allow the use of more throttle in the corners, however the car will have less traction.

ASSEMBLY VIEW

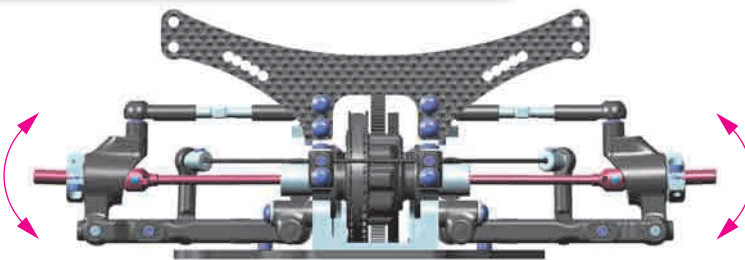
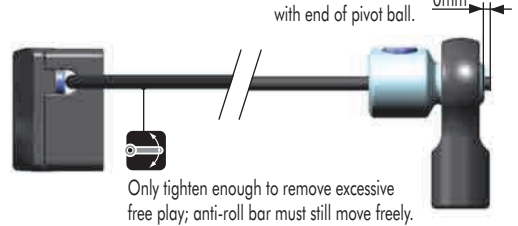

When the bars are set, verify that both sides move at the same time. If they do, the bars are set up correctly. If not, make sure that both downstops are the same and that the bar wire is flat.

SET-UP BOOK

ANTI-ROLL BARS
ADJUSTMENT

FRONT

FRONT ANTI-ROLL BARS

#302482	FRONT 1.2 MM
#202483	FRONT 1.3 MM
#302484	FRONT 1.4 MM
#302485	FRONT 1.5 MM
#302486	FRONT 1.6 MM
#302488	FRONT 1.8 MM

REAR

REAR ANTI-ROLL BARS

#303481	REAR 1.1 MM
#303482	REAR 1.2 MM
#203483	REAR 1.3 MM
#303484	REAR 1.4 MM
#303485	REAR 1.5 MM
#303486	REAR 1.6 MM

6. SHOCK ABSORBERS

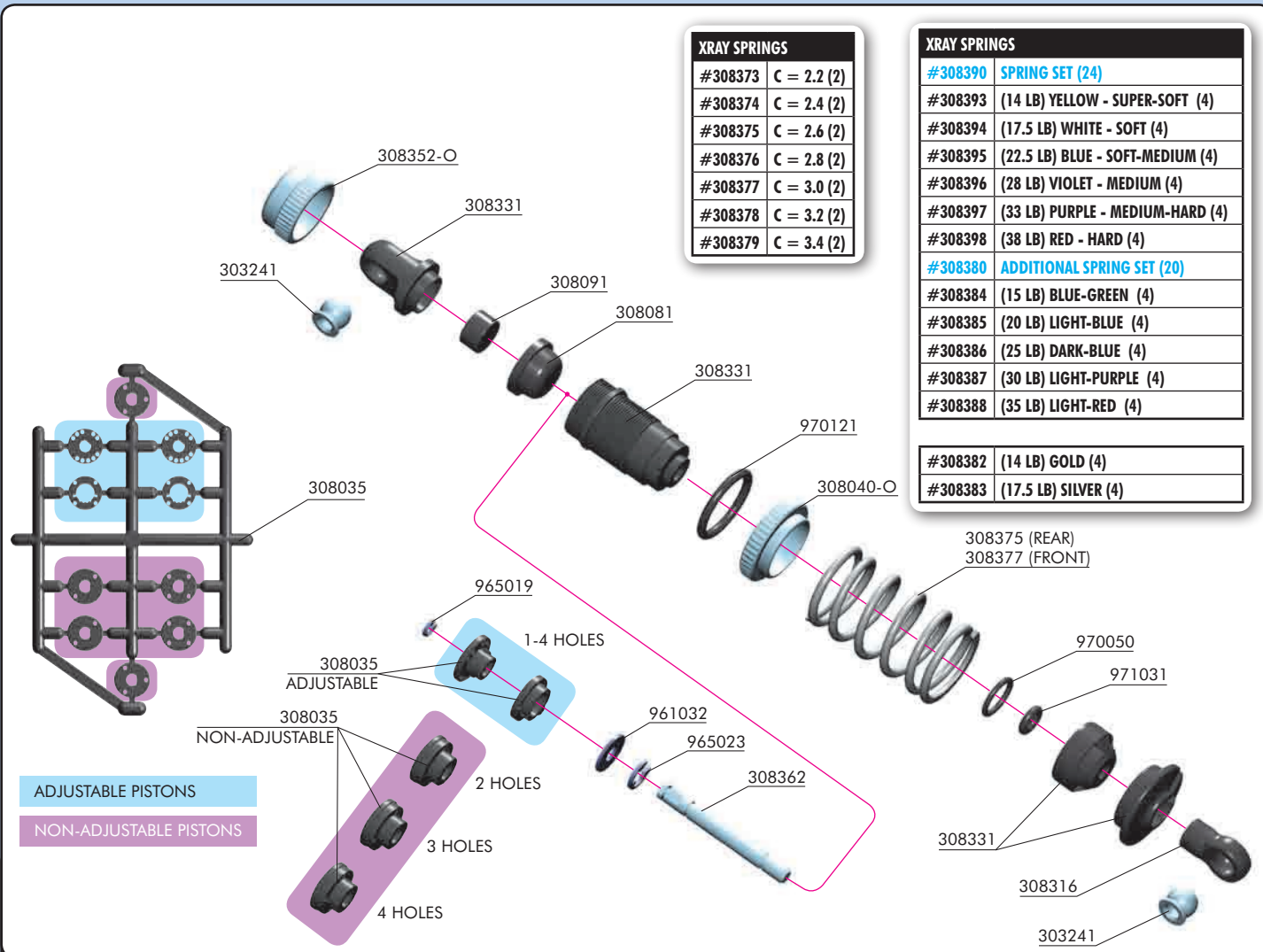

XRAY SPRINGS	
#308373	C = 2.2 (2)
#308374	C = 2.4 (2)
#308375	C = 2.6 (2)
#308376	C = 2.8 (2)
#308377	C = 3.0 (2)
#308378	C = 3.2 (2)
#308379	C = 3.4 (2)

XRAY SPRINGS	
#308390	SPRING SET (24)
#308393	(14 LB) YELLOW - SUPER-SOFT (4)
#308394	(17.5 LB) WHITE - SOFT (4)
#308395	(22.5 LB) BLUE - SOFT-MEDIUM (4)
#308396	(28 LB) VIOLET - MEDIUM (4)
#308397	(33 LB) PURPLE - MEDIUM-HARD (4)
#308398	(38 LB) RED - HARD (4)
#308380	ADDITIONAL SPRING SET (20)
#308384	(15 LB) BLUE-GREEN (4)
#308385	(20 LB) LIGHT-BLUE (4)
#308386	(25 LB) DARK-BLUE (4)
#308387	(30 LB) LIGHT-PURPLE (4)
#308388	(35 LB) LIGHT-RED (4)
#308382	(14 LB) GOLD (4)
#308383	(17.5 LB) SILVER (4)

BAG

06

- | | | | |
|-----------|--|---------|--|
| 30 3241 | BALL UNIVERSAL 5.8 MM HEX (4) | 30 8390 | XRAY SELECTED ULTIMATE RACING SPRINGS (24) |
| 30 8035 | COMPOSITE PISTONS ADJUSTABLE + NON-ADJUST. (SET 2+6) | 30 8375 | XRAY SPRING-SET C=2.6 |
| 30 8040-O | SHOCK ADJ. NUT ALU - ORANGE + O-RING (4+4) | 30 8377 | XRAY SPRING-SET C=3.0 |
| 30 8081 | SHOCK ABSORBER MEMBRANES - LOW (4) | 96 1032 | WASHER S 3.2 (10) |
| 30 8091 | SHOCK FOAM INSERTS - LOW (4) | 96 5019 | E-CLIP 1.9 (10) |
| 30 8302-O | XRAY SHOCK ABSORBER-SET 4-STEP - ORANGE - SHORT (2) | 96 5023 | E-CLIP 2.3 (10) |
| 30 8306-O | XRAY ALU SHOCK ABSORBER-SET - ORANGE (2) (OPTION) | 97 0050 | O-RING 5x1 (10) |
| 30 8316 | SHOCK BALL JOINT - OPEN (4) | 97 0121 | O-RING 12.1x1.6 (10) |
| 30 8331 | COMPOSITE FRAME SHOCK PARTS 4-STEP - SHORT - V2 | 97 1031 | SILICONE O-RING 3.1x1.6 (10) |
| 30 8352-O | ALU SHOCK CAP-NUT WITH VENT HOLE - ORANGE (2) | | |
| 30 8362 | HARDENED SHOCK SHAFT - SHORT (2) | | |
| 30 8380 | ADDITIONAL XRAY ULTIMATE RACING SPRINGS (20) | | |

ADJUSTABLE PISTONS

4x



Carefully remove the shock pistons from the frame, and remove all excess plastic flash



961032
S3.2



965019
C1.9



965023
C2.3

ADJUSTABLE PISTONS
INITIAL ASSEMBLY

4x



965019
C1.9



965023
C2.3

NON-ADJUSTABLE PISTONS
ALTERNATIVE

4x



6. SHOCK ABSORBERS



4x

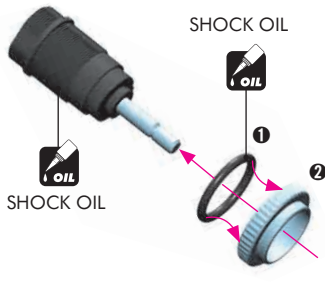
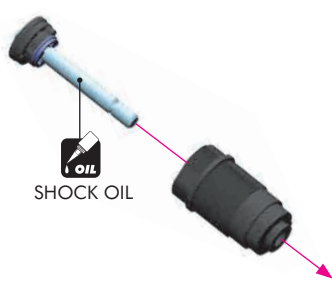

CUTAWAY VIEW



Be careful not to cross-thread the collar on the shock body.



4x

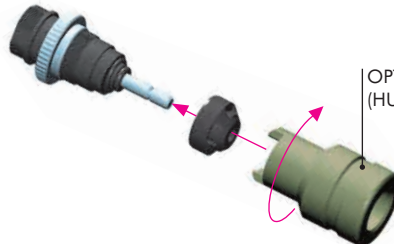
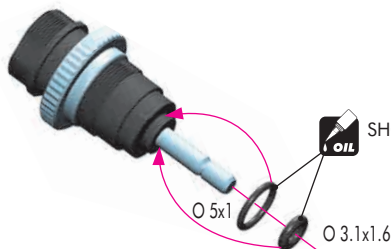

4x

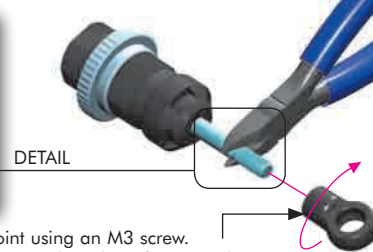
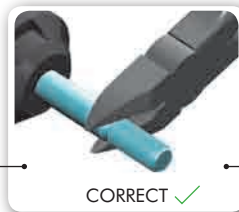
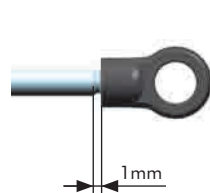

HINT: Pre-thread the ball joint using an M3 screw.
WARNING! Be careful not to pre-thread too far, since the ball joint may split or the plastic threads may strip out

4x



SHOCK FILLING

- 1 Fully extend the piston rod so the piston is at the bottom of the shock body.
- 2 Hold the shock upright and slightly overfill the shock body with shock oil.
- 3 Let the oil settle and allow air bubbles to rise to the top. Slowly move the piston up and down until no more air bubbles appear. Add shock oil as necessary.
- 4 Pull the piston rod most of the way out of the shock body. Let the shock rest for 5 minutes to allow the air bubbles to escape.



4x



CUTAWAY VIEW



After you insert the membrane ensure that it sits properly all around the alu cup.

4x



When installing the shock cap assembly on the shock body, some oil will leak out... this is normal.

Tighten the cap gently and clean off any excess oil. If the cap is tightened too much, rebound is difficult to adjust. If the cap is not tightened enough, the cap may unscrew slightly and the shock may leak.

After the shock is assembled, the shock rod will push itself out of the shock body fairly quickly.

Follow the next procedure to adjust the rebound.

SHOCK OILS

#359210	100cSt (XRAY 20W)	#359245	450cSt
#359215	150cSt	#359250	500cSt
#359220	200cSt (XRAY 25W)	#359260	600cSt (XRAY 35W)
#359225	250cSt	#359270	700cSt
#359230	300cSt	#359280	800cSt
#359235	350cSt (XRAY 30W)	#359290	900cSt
#359240	400cSt	#359301	1000cSt (XRAY 40W)
		#359302	2000cSt (XRAY 50W)



6. SHOCK ABSORBERS

REBOUND ADJUSTMENT

1. RELEASE

2.

3. TIGHTEN

REBOUND CHECK

REBOUND

0% 25% 50% 75% 100%

After the shock is assembled you have to set the Shock Rebound.

1. Release the shock composite lower cap.
2. VERY SLOWLY do the following: Fully pull out the shock rod, push it back in fully, and then fully pull it out once more. Repeat this procedure the following number of times to achieve the desired Shock Rebound setting:
 10 times - approximately 75% rebound (high rebound - suggested for very low traction track)
 15 times - approximately 50% rebound (medium rebound - suggested for standard track)
 20 times - approximately 25% rebound (low rebound - suggested for very high traction track)
3. After you have set the Rebound Adjustment, re-install the shock lower composite cap.
4. Check the Shock Rebound setting by pushing the shock rod fully into the shock body, releasing it, and observing how far the shock rod extends by itself:
 * 25% out of the shock body (low rebound)
 * 50% out of the shock body (medium rebound)
 * 75% out of the shock body (high rebound).
 If the shock rod rebounds too much, return to Step 1 and repeat the procedure.

During the Rebound Adjustment procedure shock oil will leak out of the shock body through the O-ring on the shock rod... this is normal. During the Rebound Adjustment procedure DO NOT open the upper shock cap.

If the shock rod does not rebound enough, you will have to refill the shock with shock oil, and then repeat the bleeding and Shock Rebound procedures.

Cutaway view of assembled shock absorber

SOFTEST 4 HARDEST 1

2 3

1

Shock length adjustment:

It is VERY important that all shocks are equal length. Fully extend the shock absorber and measure the end-to-end length; we recommend using digital calipers to give an accurate measurement. If a shock absorber is shorter or longer than others, adjust the shock length by tightening or loosening the ball joint on the shock rod.

Damping adjustment:

If you built the adjustable shocks, fully extend the shock rod and turn it slightly to lock the piston in the shock body.

Turning the shock rod fully CCW aligns 4 holes in the pistons (softest damping). Turning the shock rod fully CW aligns 1 hole in the pistons (hardest damping). The shocks have four settings, each of which can be felt by a slight "click".

Set all four shocks initially to position 3 (3 holes open): turn fully CCW, then turn CW by 1 click.

2x FRONT SHOCKS (C=3.0 springs)

2x REAR SHOCKS (C=2.6 springs)

CHECK NEXT TECH TIP

SET-UP BOOK

SHOCK DAMPING ADJUSTMENT

SPRING RATE SELECTION

TECH TIP

Follow this tech tip to properly install pivot balls into the top pivot and bottom ball joint.

Parts Needed:

- M3 x 16 SH screw
- M3 shim

Note that the composite parts have two sides, noticeable around the pivot ball hole: one side has a shiny finish, the other side has a regular finish.

SHINY FINISH SIDE

SHINY FINISH SIDE

1

SHINY FINISH SIDE

Install pivot balls into top pivot or lower ball joint as shown, on the proper sides.

Note that the lower pivot ball has an extra shoulder.

SHINY FINISH SIDE

3

Ensure pivot balls move freely

2

Tighten screw until pivot ball snaps into place

4

Remove screw and shim

7. FRONT & REAR ASSEMBLY

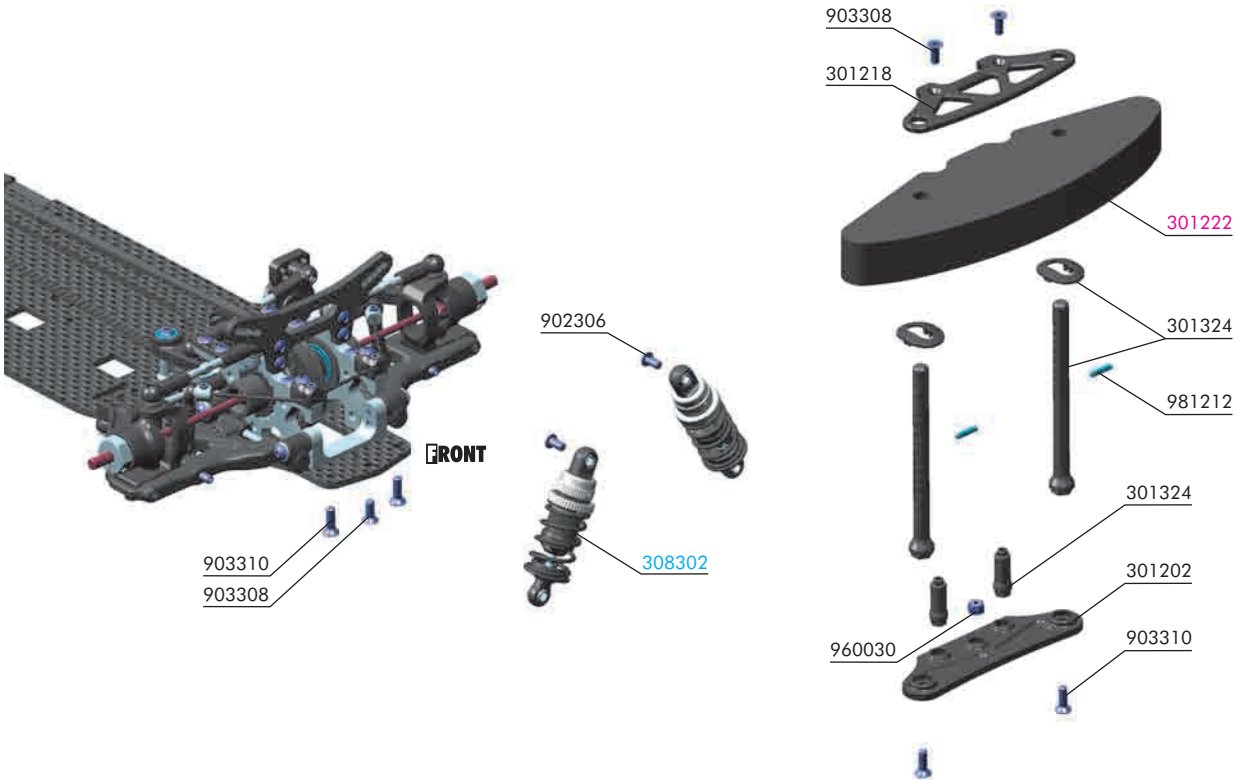

BAG

07

30 1202 COMPOSITE BUMPER
 30 1218 COMPOSITE UPPER HOLDER FOR BUMPER
 30 1324 FRONT BODY MOUNT SET +2MM HEIGHT

90 2306 HEX SCREW SH M3x6 (10)
 90 3308 HEX SCREW SFH M3x8 (10)
 90 3310 HEX SCREW SFH M3x10 (10)

96 0030 NUT M3 (10)
 98 1212 PIN 2x12 (10)

30 1222 FOAM BUMPER

30 8302 XRAY SHOCK ABSORBER-SET 4-STEP - SHORT (2)
30 8306 XRAY ALU SHOCK ABSORBER-SET (2) (OPTION)



903308
SFH M3x8

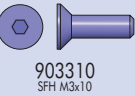

903310
SFH M3x10



960030
N M3x10

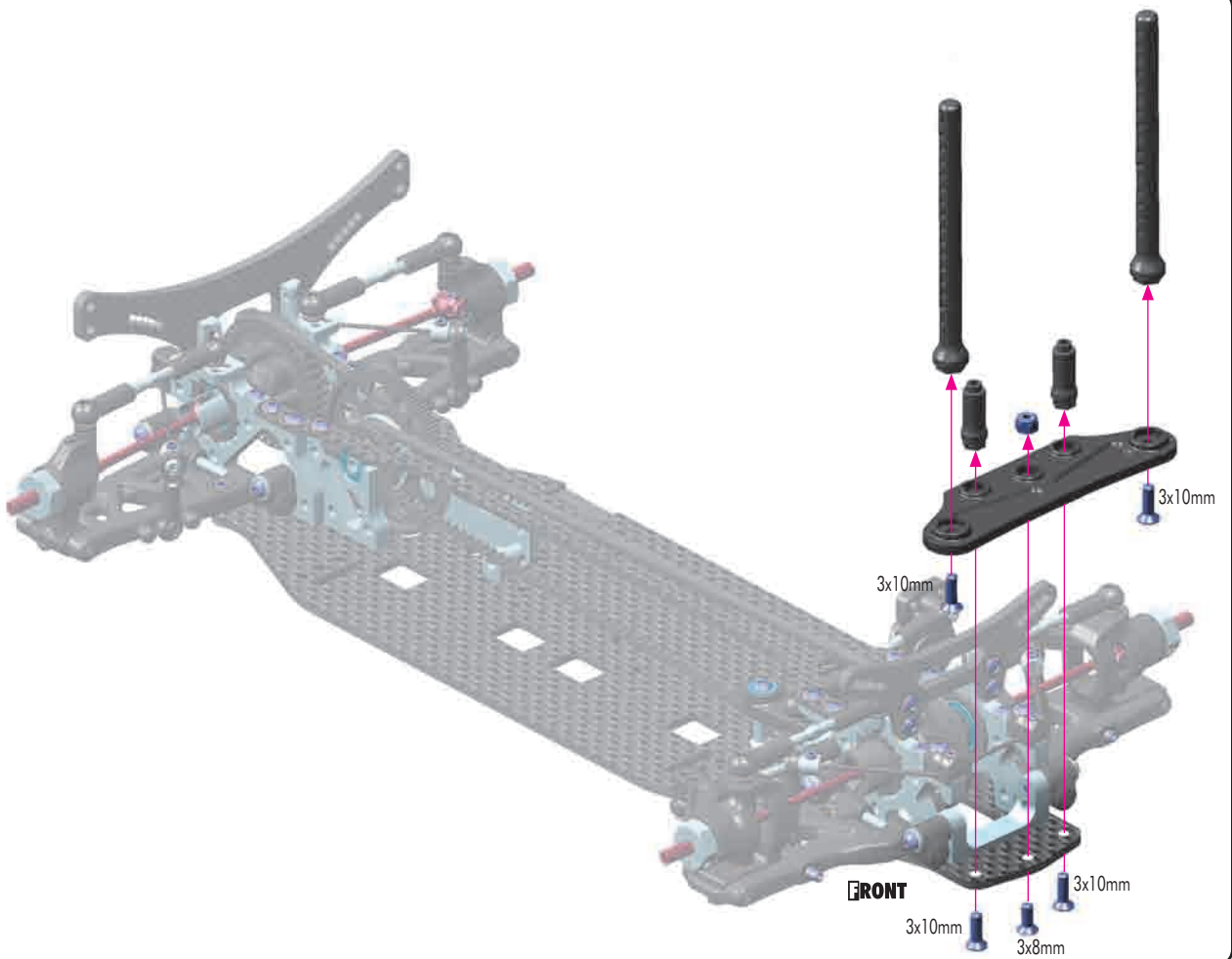

7. FRONT & REAR ASSEMBLY

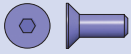

903308
SFH M3x8

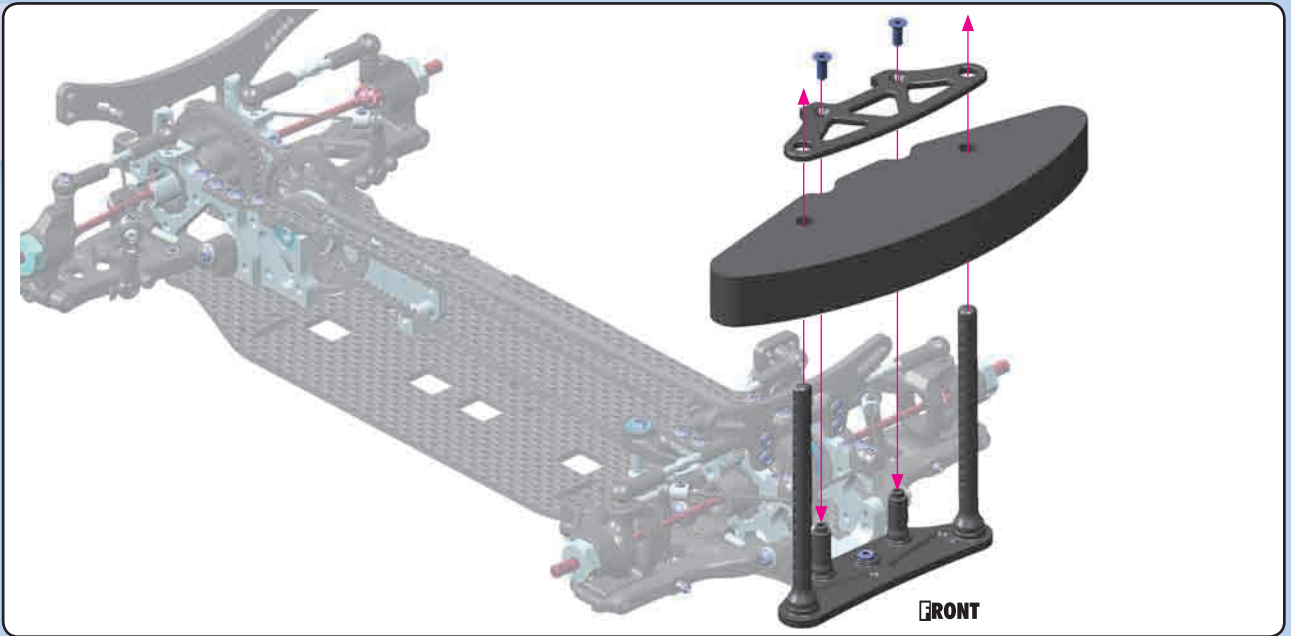

981212
P 2x12

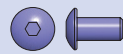
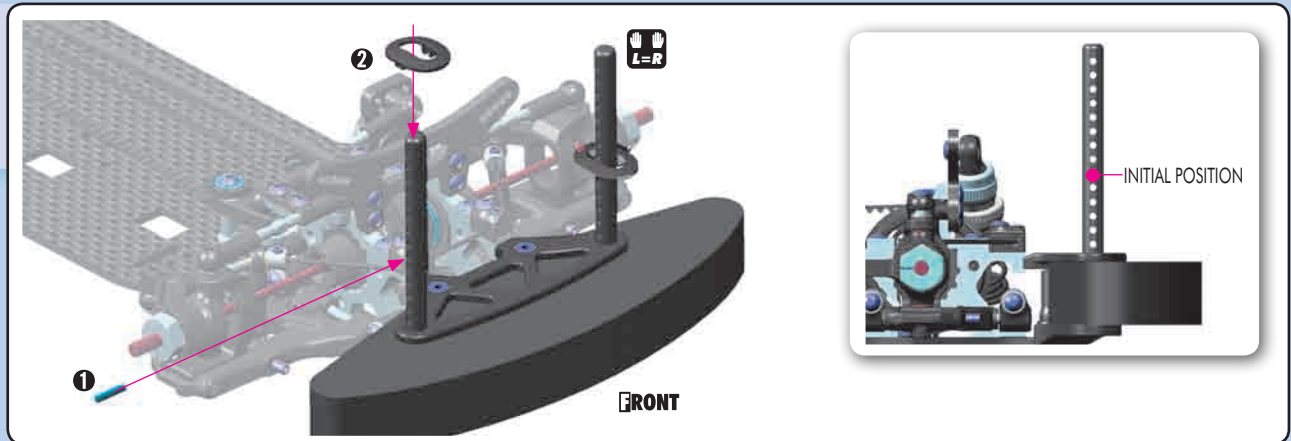

902306
SFH M3x6

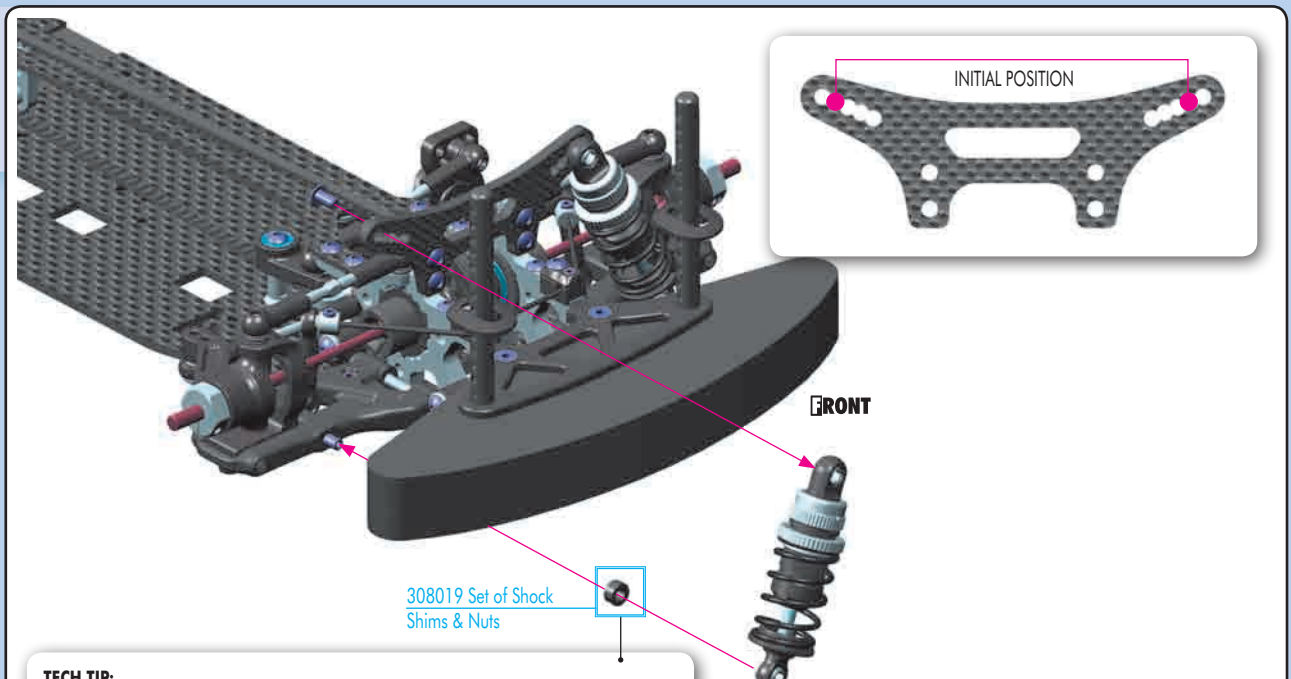

TECH TIP:

To make the car more stable and easier to drive, move the front shocks forward. Stability increases mainly in chicanes. Note that the car will have less steering into corners.

- Upper mount (shock tower): Add a plastic nut and use a longer screw 3x8mm (NOT INCLUDED) to move the upper end of the shock away from the shock tower.
- Lower mount (lower arm): Add shims and use a longer setscrew 3x10mm (NOT INCLUDED) on the lower arms to move the lower end of the shock away from the arm.

 FRONT SHOCK
C3.0 SPRING



SHOCK POSITION ADJUSTMENT
RIDE HEIGHT ADJUSTMENT
DROOP ADJUSTMENT

7. FRONT & REAR ASSEMBLY

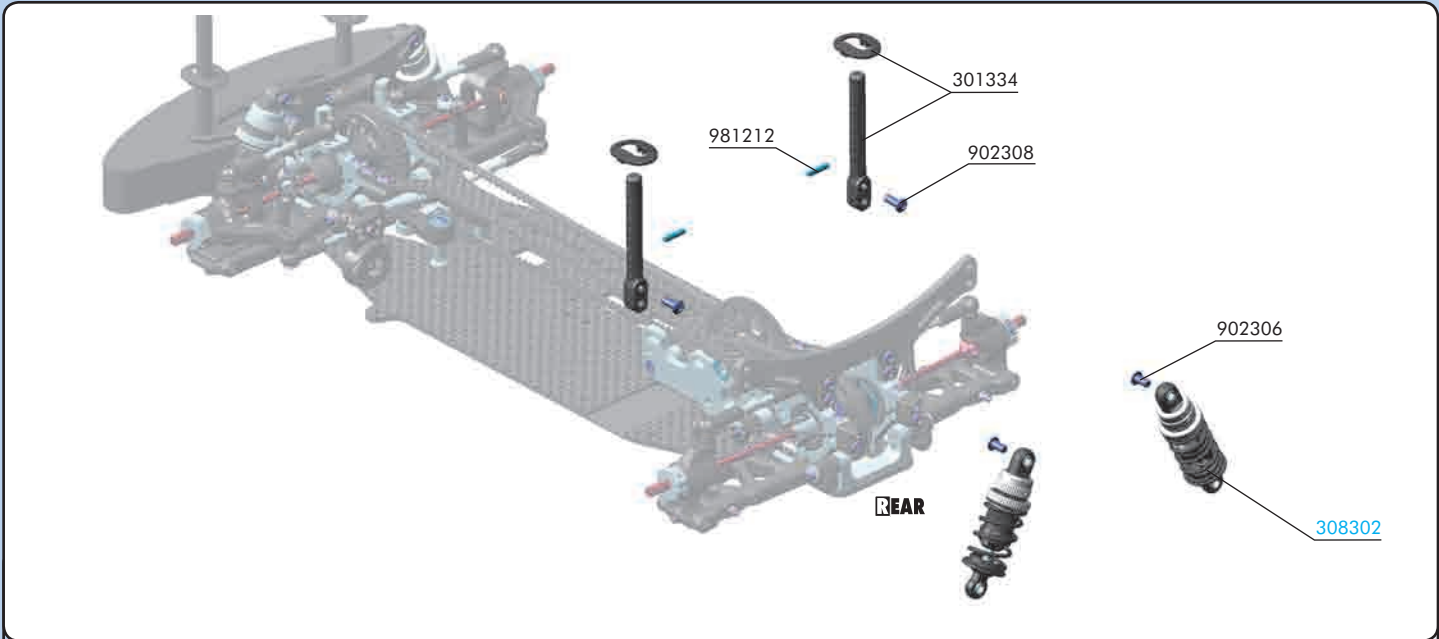

BAG 	30 1334	REAR BODY MOUNT SET +2MM HEIGHT	98 1212	PIN 2x12 (10)
	90 2306	HEX SCREW SH M3x6 (10)	30 8302	XRAY SHOCK ABSORBER-SET 4-STEP - SHORT (2)
	90 2308	HEX SCREW SH M3x8 (10)	30 8306	XRAY ALU SHOCK ABSORBER-SET (2) (OPTION)

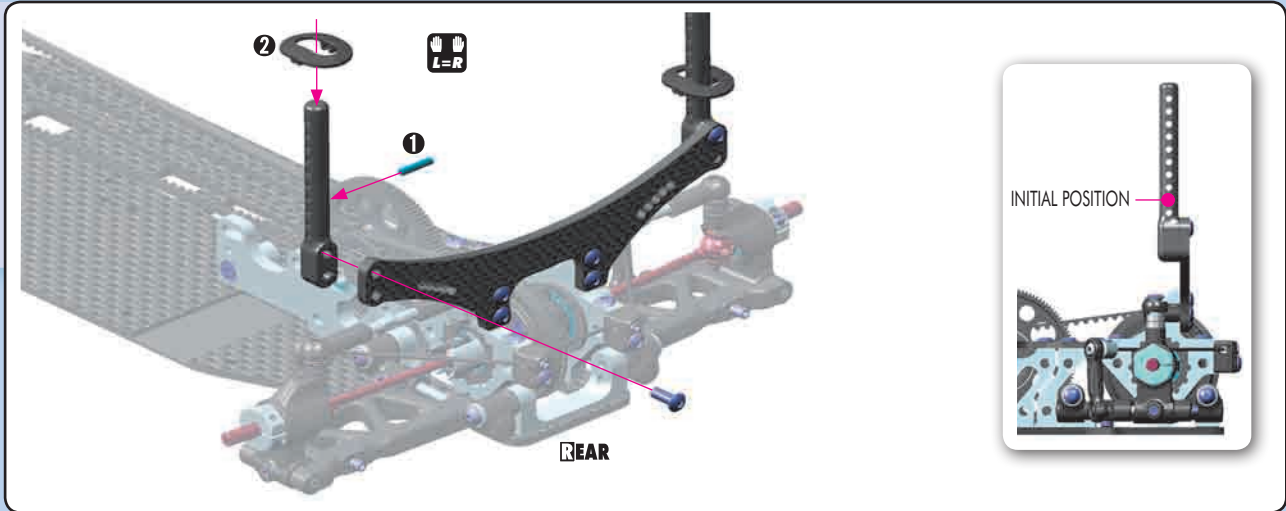

TECH TIP:
To make the car more stable and easier to drive, move the rear shocks rearward. Stability increases mainly in chicanes. Note that the car will have less steering into corners.

- Upper mount (shock tower): Add a plastic nut and use a longer screw 3x8mm (NOT INCLUDED) to space the upper end of the shock away from the shock tower.
- Lower mount (lower arm): Add shims and use a longer setscrew 3x10mm (NOT INCLUDED) on the lower arms to space the lower end of the shock away from the arm.

OPTIONAL INITIAL POSITION

When using optional 2-hole arms and optional 1-hole rear upright, use the second hole from the bottom on the shock tower.

REAR SHOCK
(C2 .6 SPRING)



7. FINAL ASSEMBLY

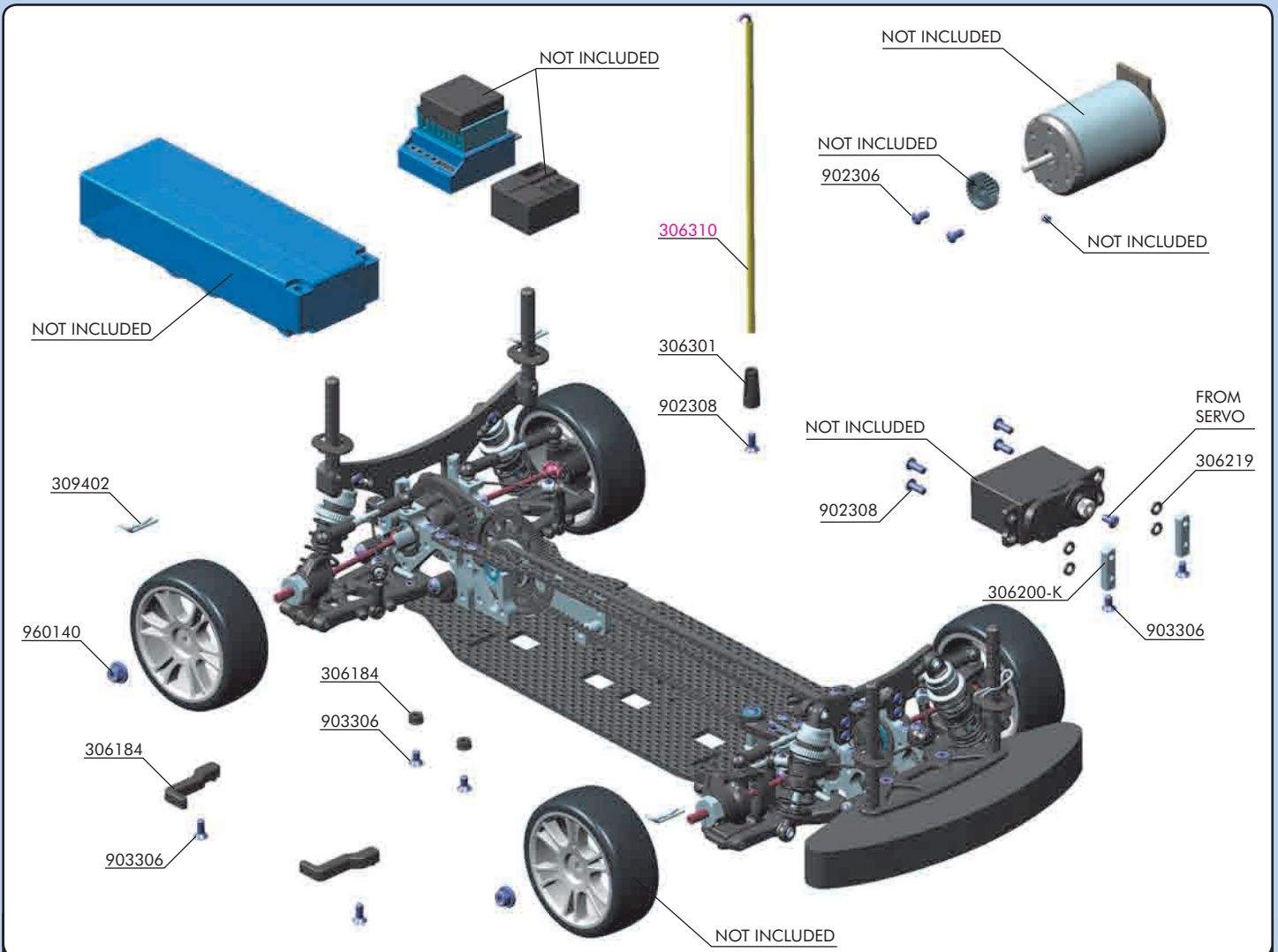

<p>BAG</p>	305912~306000	NARROW PINION GEAR ALU HARD COATED (OPTION)	90 2306	HEX SCREW SH M3x6 (10)
	30 6163-K	GRAPHITE BATTERY STRAP 6-CELL (SET) - BLACK (OPTION)	90 2308	HEX SCREW SH M3x8 (10)
	30 6184	LONG COMPOSITE LIPO BATTERY BACKSTOP (1+1)	90 3306	HEX SCREW SFH M3x6 (10)
	30 6186	ALU LIPO BATTERY BACKSTOP (F+R) (OPTION)	96 0140	NUT M4 WITH FLANGE (10)
	30 6200-K	ALU SERVO MOUNT - BLACK (2)	306310	ANTENNA (2)
	30 6219	COMPOSITE SET OF SERVO SHIMS (4)		
	30 6301	ANTENNA MOUNT - THIN		
	30 9402	BODY CLIP FOR 6MM BODY POST (4)		

- 306219**
SHIM 3x6x1
- 306219**
SHIM 3x6x2
- 306219**
SHIM 3x6x3
- 902308**
SH M3x8
- 903306**
SFH M3x6

For improved weight balance and for more space for electronics, we recommend using a narrow, light servo.

TOP VIEW DETAIL

→ Add shims between servo and alu servo mounts in case there is no space between servo and servosaver arm. There are 3 different thickness of shims.

We recommend using the grommets included with the servo to avoid unwanted chassis tweak.

DETAIL

Attach servo arm to servo output shaft using screw from servo. Servo saver must be perpendicular to chassis when servo is in neutral.

! IMPORTANT!

When adjusting steering on the radio, we recommend using full steering adjustment in order to get the best steering from the car. It is important to verify that the steering block does not touch the C-hub; that would lead to chassis tweak due to extra servo strain.

7. FINAL ASSEMBLY

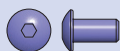

902306
SFH M3x6

When installing the motor on the bulkhead, rotate the spur gear so the motor screw can be installed through a hole in the spur gear. See the detail image below.

Adjust the motor so the pinion meshes with the spur gear properly. Make sure the gear mesh is not too tight.

There should be a small amount of play between the teeth of the pinion gear and the spur gear.

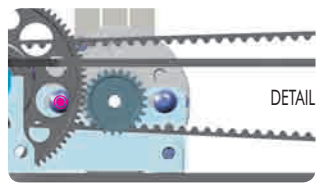

Recommended:
3x2.5mm set screw
(#901302)



Some motors do not have a chamfer on the motor housing. If your motor does not have a chamfer on the housing and you want to use a small pinion, the motor may touch the top deck. Use a moto-tool with grinding bit or file to remove material from the top-deck; this will allow the motor to be moved closer to the spur gear.

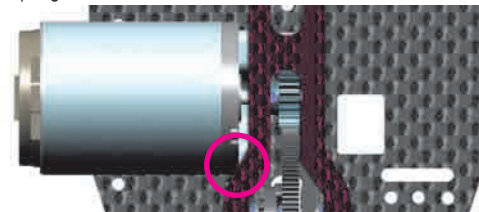

TIP For tightening and loosening the pinion set screw, use the indicated chassis hole.



GEARING ADJUSTMENT



903308
SFH M3x8

Feed the receiver wire into the antenna tube.

RECEIVER
(NOT INCLUDED)

NOTE: In case the antenna tube does not hold the antenna properly, apply a small drop of the CA glue to the outside end of the antenna tube while inserting it into the holder. Make sure not to apply glue to the inside of the antenna tube, or the antenna wire may get permanently stuck.



SPEED CONTROLLER
(NOT INCLUDED)

DOUBLE-SIDED TAPE
(NOT INCLUDED)

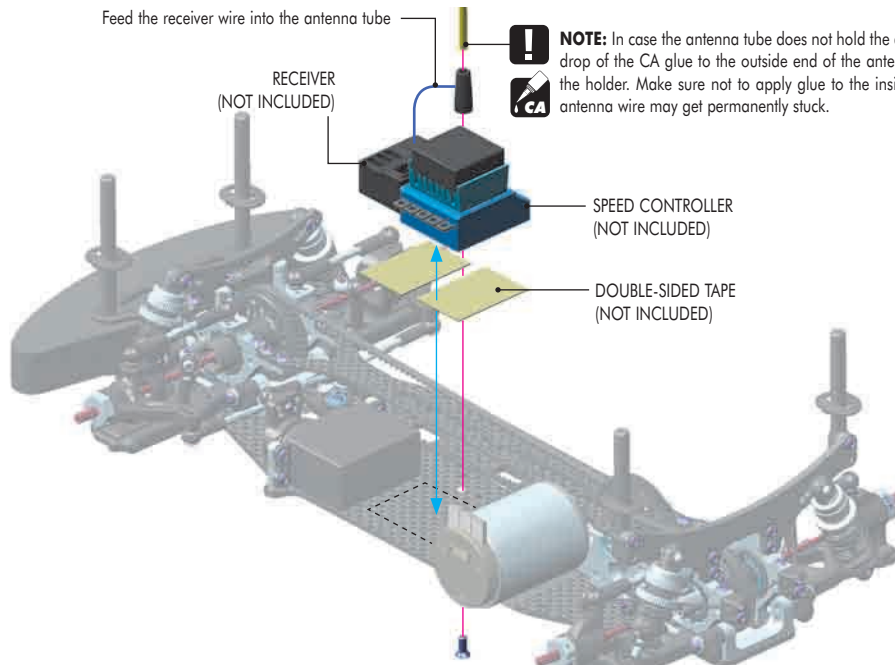

903306
SFH M3x6

REAR

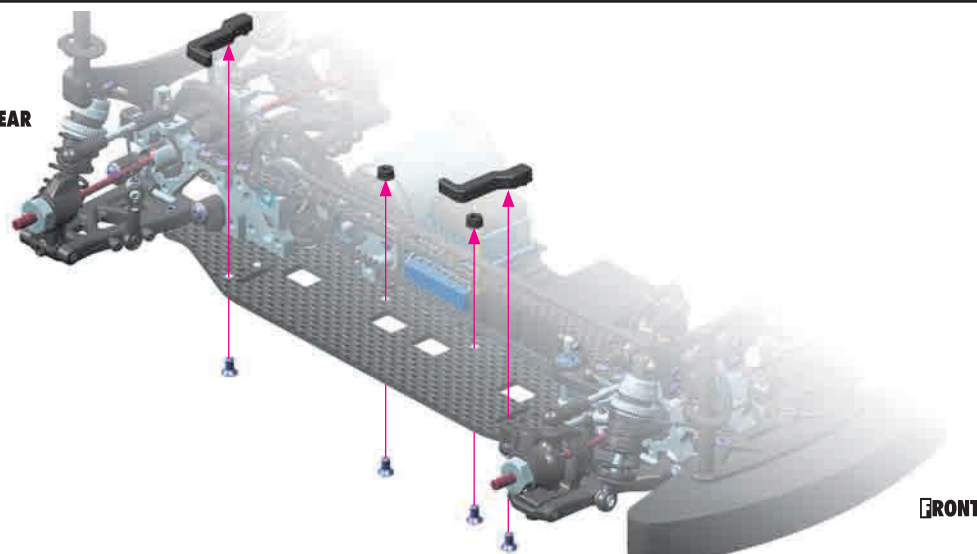

FRONT

7. FINAL ASSEMBLY

4x



WHEELS & TIRES & INSERTS
(NOT INCLUDED)

! WARNING!
Follow the adhesive manufacturer's instructions for proper use and safety. Wear proper eye and hand protection.

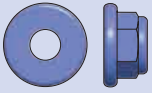

960140
N M4



We recommend using #107870
HUDY Fibre Reinforced Tape

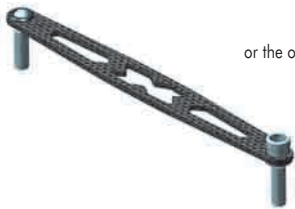

or the optional battery holders: #306163-K XRAY Graphite Battery Holder - Black
The XRAY Graphite Battery Holder can be used for LiPo as well. However, depending on the height of the LiPo batteries additional shims may have to be mounted below the stands.

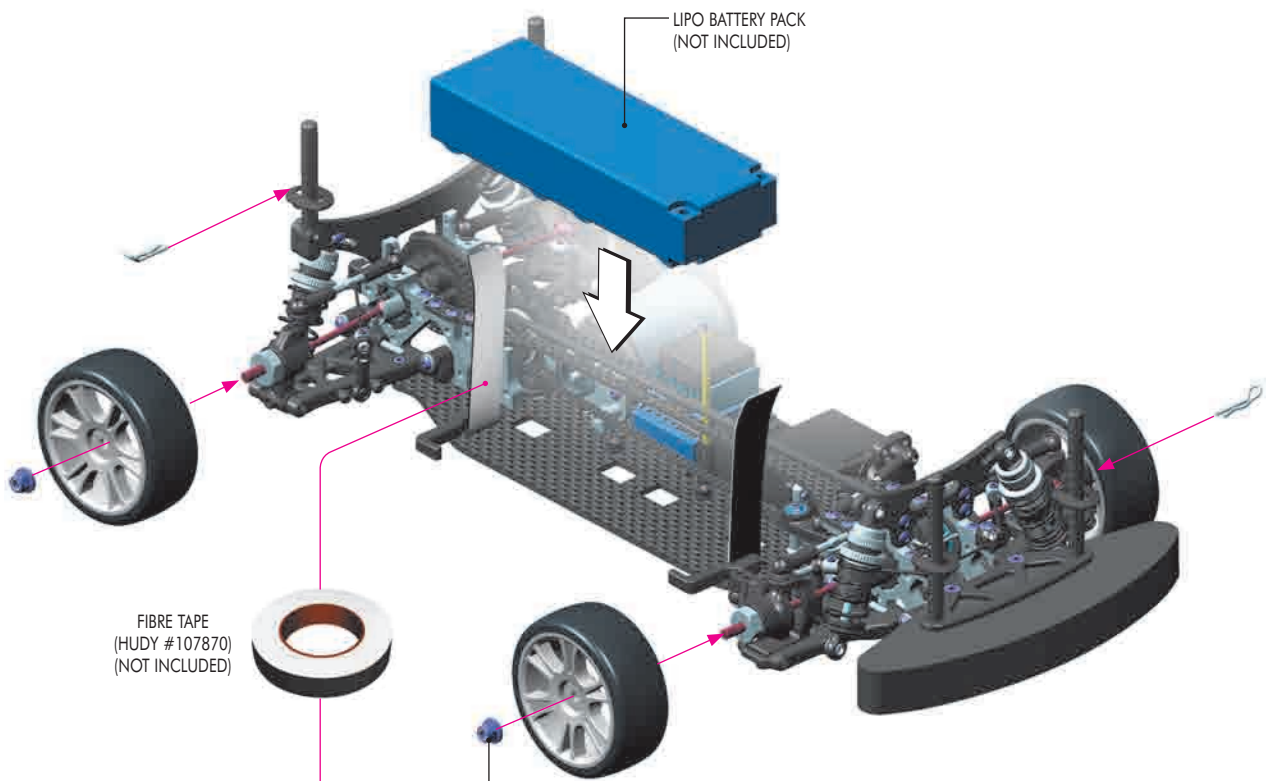

LIPO BATTERY PACK
(NOT INCLUDED)

FIBRE TAPE
(HUDY #107870)
(NOT INCLUDED)

Make sure the wheel nuts are very tight, so the wheels do not loosen during racing.

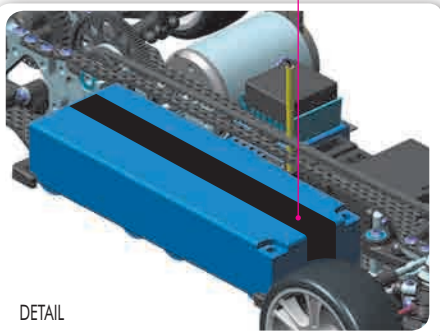

DETAIL



SET-UP SHEET

XRAY T3'12

RACE			
TRACK			
NAME			
CITY / COUNTRY			
CONTACT			

DATE	TEMPERATURE / °F or °C	AIR	TRACK
QUALIFYING POSITION	BEST LAP TIME /sec	FINAL POSITION	RACE LENGTH /minutes

TRACK CONDITION			
<input type="checkbox"/> TECHNICAL	<input type="checkbox"/> CARPET	<input type="checkbox"/> ASPHALT	
<input type="checkbox"/> MIXED	<input type="checkbox"/> FAST		
TRACTION			
<input type="checkbox"/> LOW	<input type="checkbox"/> MEDIUM	<input type="checkbox"/> HIGH	

FRONT		REAR	
TRANSMISSION			
SOLID AXLE <input type="checkbox"/> YES	BALL DIFFERENTIAL <input type="checkbox"/> YES		
SOLID ONE WAY DIFF. <input type="checkbox"/> YES			
ONE WAY DIFFERENTIAL <input type="checkbox"/> YES			
GEAR DIFFERENTIAL <input type="checkbox"/> YES	GEAR DIFFERENTIAL <input type="checkbox"/> YES		
OIL	OIL /cst		

PINION / T	SPUR GEAR / T
FINAL DRIVE RATIO	ROLLOUT

FRONT		REAR	
<input type="checkbox"/> ALU	<input type="checkbox"/> PLASTIC	SHOCKS	<input type="checkbox"/> ALU <input type="checkbox"/> PLASTIC
XRAY SPRINGS			
	OIL / CST		
	LENGTH /mm		
	PRELOAD /mm		
	REBOUND %		
<input type="checkbox"/> YES <input type="checkbox"/> NO	FOAM INSERTS	<input type="checkbox"/> YES <input type="checkbox"/> NO	
<input type="checkbox"/> YES <input type="checkbox"/> NO	O-RING ON SHAFT	<input type="checkbox"/> YES <input type="checkbox"/> NO	

<input type="radio"/> OPENED	<input type="radio"/> CLOSED	HOLES IN PISTON
<input type="radio"/>	<input type="radio"/>	<input type="radio"/>

THICKNESS/mm	ANTI-ROLL BAR	THICKNESS/mm
--------------	----------------------	--------------

TIRES	
DIAMETER /mm	
INSERTS	
ADDITIVE	

FRONT LEFT	FRONT RIGHT	REAR LEFT	REAR RIGHT
<input type="checkbox"/>	<input type="checkbox"/>	<input type="checkbox"/>	<input type="checkbox"/>
TREATED AREA			

WHEELS			
S <input type="checkbox"/>	M <input type="checkbox"/>	H <input type="checkbox"/>	HARDNESS
S <input type="checkbox"/>	M <input type="checkbox"/>	H <input type="checkbox"/>	

MOTOR	TIMING
ROTOR	ARMATURE

ESC	BATTERIES
------------	------------------

BRUSHLESS			
PROGRAM	PUNCH	INITIAL BRAKE	AUTO BRAKE

BODY	WING
-------------	-------------

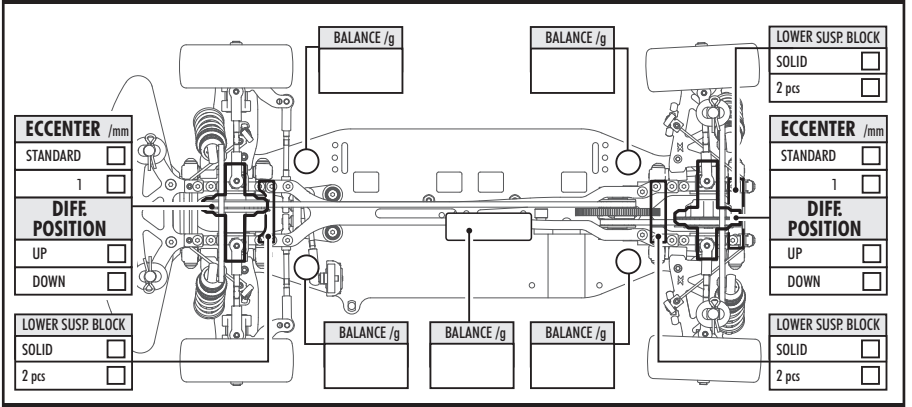
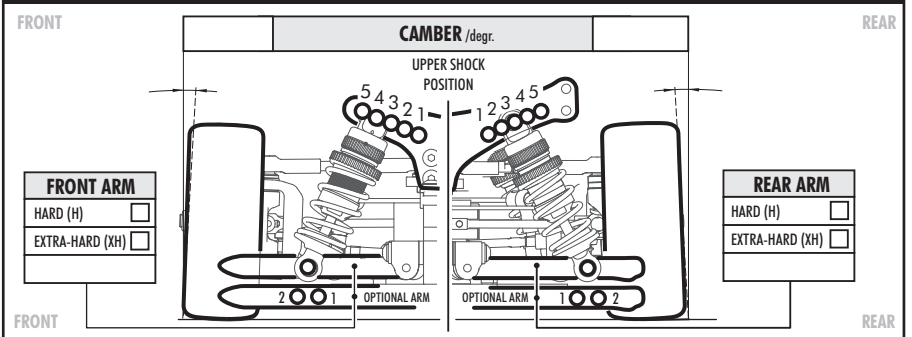
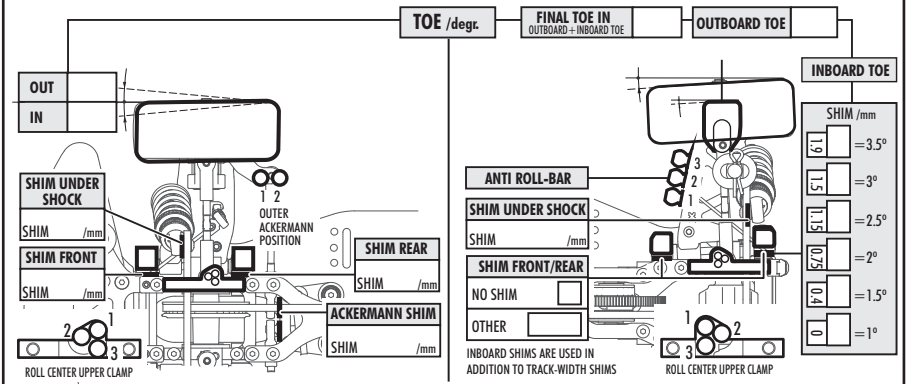
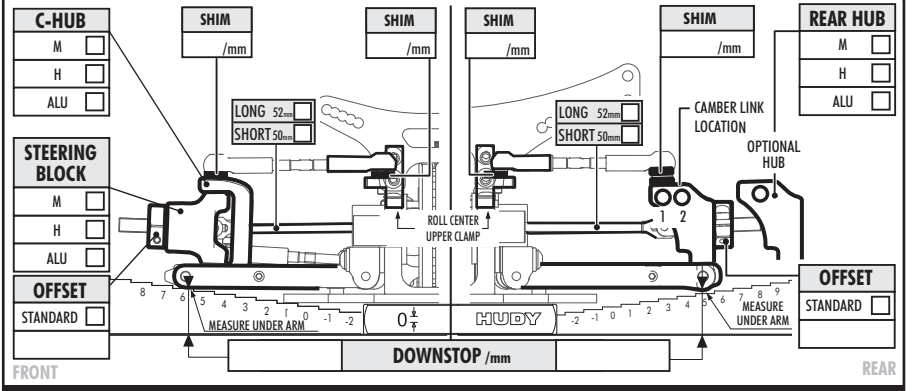
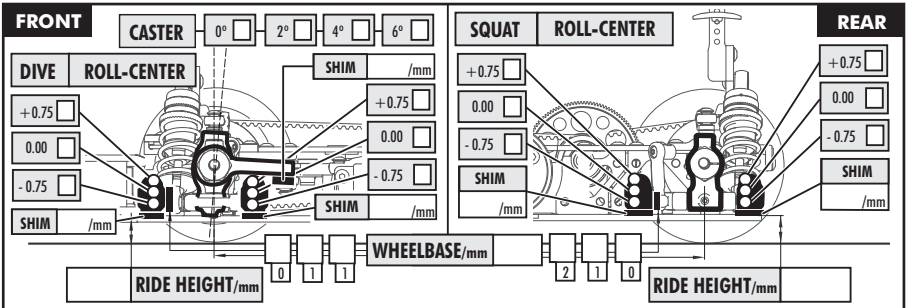

teamxray.com

XRAY EUROPE

XRAY, K VÝSTAVISKU 6992, 91101 TRENCIN, SLOVAKIA, EUROPE
PHONE: +421-32-740 11 00, FAX: +421-32-740 11 09, info@teamxray.com

XRAY USA

RC AMERICA, 2970 BLYSTONE LANE, SUITE 109, DALLAS, 75220 TEXAS, USA
PHONE: 214-744-2400, FAX: 214-744-2401, xray@rcamerica.com



Follow us on:

 www.facebook.com/teamxray

 www.twitter.com/teamxray

 www.youtube.com/xrayracing

ALL RIGHTS RESERVED. © XRAY. ALL ARTWORK & DESIGN BY XRAY

