

XRAY
1/10 LUXURY ELECTRIC TOURING CAR 4WD

T4

2018

**INSTRUCTION
MANUAL**

MADE IN
EUROPE

**WORLD
VICE-CHAMPION
2X**

**EUROPEAN
CHAMPION
Modified**

**5X
EUROPEAN
CHAMPION
Stock**

**2X
ETS
EURO TOURING SERIES
SEASON WINNER
MODIFIED**

**6X
ETS
EURO TOURING SERIES
SEASON WINNER
STOCK**

**49X
USA
NATIONAL
CHAMPION**

BEFORE YOU START

The T4 is a high-competition, high-quality, 1/10-scale touring car intended for persons aged 16 years and older with previous experience building and operating RC model racing cars. This is not a toy; it is a precision racing model. This model racing car is not intended for use by beginners, inexperienced customers, or by children without direct supervision of a responsible, knowledgeable adult. If you do not fulfill these requirements, please return the kit in unused and unassembled form back to the shop where you have purchased it.

Before building and operating your T4, **YOU MUST** read through all of the operating instructions and instruction manual and fully understand them to get

CUSTOMER SUPPORT

We have made every effort to make these instructions as easy to understand as possible. However, if you have any difficulties, problems, or questions, please do not hesitate to contact the XRAY support team at info@teamxray.com. Also, please visit our Web site at www.teamxray.com to find the latest updates, set-up information, option parts, and many other goodies. We pride ourselves on taking excellent care of our customers.

You can join thousands of XRAY fans and enthusiasts in our online community at:

www.teamxray.com

Failure to follow these instructions will be considered as abuse and/or neglect.

SAFETY PRECAUTIONS

Contains:

LEAD (CAS 7439-92-1) ANTIMONY (CAS 7440-36-0)

WARNING: This product contains a chemical known to the state of California to cause cancer and birth defects or other reproductive harm.

CAUTION: CANCER HAZARD

Contains lead, a listed carcinogen. Lead is harmful if ingested. Wash thoroughly after using. DO NOT use product while eating, drinking or using tobacco products. May cause chronic effects to gastrointestinal tract, CNS, kidneys, and blood. MAY CAUSE BIRTH DEFECTS.

When building, using and/or operating this model always wear protective glasses and gloves.

Take appropriate safety precautions prior to operating this model. You are responsible for this model's assembly and safe operation! Please read the instruction manual before building and operating this model and follow all safety precautions. Always keep the instruction manual at hand for quick reference, even after completing the assembly. Use only genuine and original authentic XRAY parts for maximum performance. Using any third party parts on this model will void guaranty immediately.

IMPORTANT NOTES - GENERAL

- This product is not suitable for children under 16 years of age without the direct supervision of a responsible and knowledgeable adult.
- Carefully read all manufacturers warnings and cautions for any parts used in the construction and use of your model.
- Assemble this kit only in places away from the reach of very small children.
- First-time builders and users should seek advice from people who have building experience in order to assemble the model correctly and to allow the model to reach its performance potential.
- Exercise care when using tools and sharp instruments.
- Take care when building, as some parts may have sharp edges.
- Keep small parts out of reach of small children. Children must not be allowed to put any parts in their mouth, or pull vinyl bag over their head.
- Read and follow instructions supplied with paints and/or cement, if used (not included in kit).
- Immediately after using your model, do NOT touch equipment on the model such as the motor and speed controller, because they generate high temperatures. You may seriously burn yourself seriously touching them.
- Follow the operating instructions for the radio equipment at all times.
- Do not put fingers or any objects inside rotating and moving parts, as this may cause damage or serious injury as your finger, hair, clothes, etc. may get caught.
- Be sure that your operating frequency is clear before turning on or running your model, and never share the same frequency with somebody else at the same time. Ensure that others are aware of the operating frequency you are using and when you are using it.
- Use a transmitter designed for ground use with RC cars. Make sure that no one else is using the same frequency as yours in your operating area. Using the same frequency at the same time, whether it is driving, flying or sailing, can cause loss of control of the RC model, resulting in a serious accident.
- Always turn on your transmitter before you turn on the receiver in the car. Always turn off the receiver before turning your transmitter off.
- Keep the wheels of the model off the ground when checking the operation of the radio equipment.
- Disconnect the battery pack before storing your model.
- When learning to operate your model, go to an area that has no obstacles that can damage your model if your model suffers a collision.
- Remove any sand, mud, dirt, grass or water before putting your model away.
- If the model behaves strangely, immediately stop the model, check and clear the problem.
- To prevent any serious personal injury and/or damage to property, be responsible when operating all remote controlled models.
- The model car is not intended for use on public places and roads or areas where its operation can conflict with or disrupt pedestrian or vehicular traffic.
- Because the model car is controlled by radio, it is subject to radio interference from many sources that are beyond your control. Since radio interference can cause momentary loss of control, always allow a safety margin in all directions around the model in order to prevent collisions.
- Do not use your model:
 - Near real cars, animals, or people that are unaware that an RC car is being driven.
 - In places where children and people gather
 - In residential districts and parks
 - In limited indoor spaces
 - In wet conditions
 - In the street
 - In areas where loud noises can disturb others, such as hospitals and residential areas.
 - At night or anytime your line of sight to the model may be obstructed or impaired in any way.

the maximum enjoyment and prevent unnecessary damage. Read carefully and fully understand the instructions before beginning assembly.

Make sure you review this entire manual, download and use set-up book from the web, and examine all details carefully. If for some reason you decide The T4 is not what you wanted or expected, do not continue any further. Your hobby dealer cannot accept your T4 kit for return or exchange after it has been partially or fully assembled.

Contents of the box may differ from pictures. In line with our policy of continuous product development, the exact specifications of the kit may vary without prior notice.

XRAY Europe

K Vystavisku 6992
91101 Trenčín
Slovakia, EUROPE
Phone: 421-32-7401100
Fax: 421-32-7401109
E-mail: info@teamxray.com

XRAY USA

RC America, 2030 Century Center Blvd #15
Irving, TX 75062
USA
Phone: (214) 744-2400
Fax: (214) 744-2401
E-mail: xray@rcamerica.com

IMPORTANT NOTES - ELECTRICAL

- Insulate any exposed electrical wiring (using heat shrink tubing or electrical tape) to prevent dangerous short circuits. Take maximum care in wiring, connecting and insulating cables. Make sure cables are always connected securely. Check connectors for if they become loose. And if so, reconnect them securely. Never use RC models with damaged wires. A damaged wire is extremely dangerous, and can cause short-circuits resulting in fire. Please have wires repaired at your local hobby shop.
- Low battery power will result in loss of control. Loss of control can occur due to a weak battery in either the transmitter or the receiver. Weak running battery may also result in an out of control car if your car's receiver power is supplied by the running battery. Stop operation immediately if the car starts to slow down.
- When not using RC model, always disconnect and remove battery.
- Do not disassemble battery or cut battery cables. If the running battery short-circuits, approximately 300W of electricity can be discharged, leading to fire or burns. Never disassemble battery or cut battery cables.
- Use a recommended charger for the receiver and transmitter batteries and follow the instructions correctly. Over-charging, incorrect charging, or using inferior chargers can cause the batteries to become dangerously hot.

R/C & BUILDING TIPS

- Make sure all fasteners are properly tightened. Check them periodically.
- Make sure that chassis screws do not protrude from the chassis.
- For the best performance, it is very important that great care is taken to ensure the free movement of all parts.
- Clean all ball-bearings so they move very easily and freely.
- Tap or pre-thread the plastic parts when threading screws.
- Self-tapping screws cut threads into the parts when being tightened. Do not use excessive force when tightening the self-tapping screws because you may strip out the thread in the plastic. We recommended you stop tightening a screw when you feel some resistance.
- Ask your local hobby shop for any advice.

WARRANTY

XRAY guarantees this model kit to be free from defects in both material and workmanship within 30 days of purchase. The total monetary value under warranty will in no case exceed the cost of the original kit purchased. This warranty does not cover any components damaged by use or modification or as a result of wear. Part or parts missing from this kit must be reported within 30 days of purchase. No part or parts will be sent under warranty without proof of purchase. Should you find a defective or missing part, contact the local distributor. Service and customer support will be provided through local hobby store where you have purchased the kit, therefore make sure to purchase any XRAY products at your local hobby store. This model racing car is considered to be a high-performance racing vehicle. As such this vehicle will be used in an extreme range of conditions and situations, all which may cause premature wear or failure of any component. XRAY has no control over usage of vehicles once they leave the dealer, therefore XRAY can only offer warranty against all manufacturer's defects in materials, workmanship, and assembly at point of sale and before use. No warranties are expressed or implied that cover damage caused by what is considered normal use, or cover or imply how long any model cars' components or electronic components will last before requiring replacement.

Due to the high performance level of this model car you will need to periodically maintain and replace consumable components. Any and all warranty coverage will not cover replacement of any part or component damaged by neglect, abuse, or improper or unreasonable use. This includes but is not limited to

QUALITY CERTIFICATE

XRAY MODEL RACING CARS uses only the highest quality materials, the best compounds for molded parts and the most sophisticated manufacturing processes of TQM (Total Quality Management). We guarantee that all parts of a newly-purchased kit are manufactured with the highest regard to quality. However, due to the many factors inherent in model racecar competition, we cannot guarantee

Recharge battery when necessary. Continual recharging may damage battery and, in the worst case, could build up heat leading to fire. If battery becomes extremely hot during recharging, please ask your local hobby shop for check and/or repair and/or replacement.

- Regularly check the charger for potential hazards such as damage to the cable, plug, casing or other defects. Ensure that any damage is rectified before using the charger again. Modifying the charger may cause short-circuit or overcharging leading to a serious accident. Therefore do not modify the charger.
- Always unplug charger when recharging is finished.
- Do not recharge battery while battery is still warm. After use, battery retains heat. Wait until it cools down before charging.
- Do not allow any metal part to short circuit the receiver batteries or other electrical/electronic device on the model.
- Immediately stop running if your RC model gets wet as may cause short circuit.
- Please dispose of batteries responsibly. Never put batteries into fire.

Please support your local hobby shop. We at XRAY Model Racing Cars support all local hobby dealers. Therefore we ask you, if at all possible, to purchase XRAY products at your hobby dealer and give them your support like we do. If you have difficulty finding XRAY products, please check out www.teamxray.com to get advice, or contact us via email at info@teamxray.com, or contact the XRAY distributor in your country.

damage from crashing, chemical and/or water damage, excessive moisture, improper or no maintenance, or user modifications which compromise the integrity of components. Warranty will not cover components that are considered consumable on RC vehicles. XRAY does not pay nor refund shipping on any component sent to XRAY or its distributors for warranty. XRAY reserves the right to make the final determination of the warranty status of any component or part.

Limitations of Liability

XRAY makes no other warranties expressed or implied. XRAY shall not be liable for any loss, injury or damages, whether direct, indirect, special, incidental, or consequential, arising from the use, misuse, or abuse of this product and/or any product or accessory required to operate this product. In no case shall XRAY's liability exceed the monetary value of this product.

Take adequate safety precautions prior to operating this model. You are responsible for this model's assembly and safe operation.

Disregard of the any of the above cautions may lead to accidents, personal injury, or property damage. XRAY MODEL RACING CARS assumes no responsibility for any injury, damage, or misuse of this product during assembly or operation, nor any addictions that may arise from the use of this product.

All rights reserved.

any parts once you start racing the car. Products which have been worn out, abused, neglected or improperly operated will not be covered under warranty. We wish you enjoyment of this high-quality and high-performance RC car and wish you best success on the track!

In line with our policy of continuous product development, the exact specifications of the kit may vary. In the unlikely event of any problems with your new kit, you should contact the model shop where you purchased it, quoting the part number.

We do reserve all rights to change any specification without prior notice. All rights reserved.

SYMBOLS USED

Part bags used 	Assemble in the specified order 	Assemble left and right sides the same way 	Pay attention here 	Assemble as many times as specified (here twice) 	Apply thread lock 	Apply CA glue 	Apply oil
Scale 	Apply grease 	Optional parts 	Ensure smooth non-binding movement 	Tighten screw gently 	Completed assembly 	Detail view 	Follow Set-up Book

TOOLS REQUIRED

HUDY TOOLS:

<p>Allen: 1.5mm</p>	<p>Allen: 2.0mm</p>	<p>Allen: 2.5mm</p>	<p>Allen: 3.0mm</p>	<p>Socket: 5.5mm</p>	<p>Socket: 7.0mm</p>	<p>Arm Reamer 3.0mm</p>	<p>Turnbuckle Wrench 4mm (HUDY #181040)</p>
<p>Scissors (HUDY #188990)</p>	<p>Combination Pliers (HUDY #189020)</p>	<p>Side Cutters (HUDY #189010)</p>	<p>Pocket Hobby Knife (HUDY #188981)</p>	<p>RC Shock-Plier Uni Tool (HUDY #183011)</p>	<p>Reamer (HUDY #107600) or (HUDY #107601)</p>		

ITEMS INCLUDED

<p>Premium Silicone Oil 400cSt (HUDY #106340)</p>	<p>Premium Silicone Oil 3000cSt (HUDY #106430)</p>
<p>Graphite Grease (HUDY #106210)</p>	

NOT INCLUDED

	<p>To ensure that you always have access to the most up-to-date version of the XRAY Set-up Book, XRAY will now be offering only the digital online version on our website www.teamxray.com. By offering this online version instead of including a hardcopy printed version in kits, you will always be assured of having the most current updated version.</p>						
<p>SAMPLE OF OPTIONAL PARTS</p> <table border="1"> <tr> <td>#30XXX</td> <td>OPTION 1</td> </tr> <tr> <td>#30XXX</td> <td>OPTION 2</td> </tr> <tr> <td>#30XXX</td> <td>OPTION 3</td> </tr> </table>	#30XXX	OPTION 1	#30XXX	OPTION 2	#30XXX	OPTION 3	<p>XRAY offers wide range of optional tuning parts which are listed in tables like these. Please refer to the exploded view of each main section to verify which part is included in the kit while all other parts are available only as an optional part and must be purchased separately.</p>
#30XXX	OPTION 1						
#30XXX	OPTION 2						
#30XXX	OPTION 3						

EQUIPMENT REQUIRED

<p>Transmitter</p>	<p>Receiver</p>	<p>Steering Servo</p>	<p>Electric Motor & Pinion Gear and Setscrew</p>	<p>Bearing Oil (HUDY #106230)</p>	<p>Speed Controller</p>
<p>190mm Bodysell</p>	<p>LiPo Battery</p>	<p>Lexan™ Paint</p>	<p>Battery Charger</p>	<p>Fibre Tape (HUDY #107870) Double-sided Tape (HUDY #107875)</p>	<p>Wheels & Tires & Inserts</p>

COLOR INDICATIONS

At the beginning of each section is an exploded view of the parts to be assembled. There is also a list of all the parts and part numbers that are related to the assembly of that section.

The part descriptions are color-coded to make it easier for you to identify the source of a part. Here are what the different colors mean:

Style A - indicates parts that are included in the bag marked for the section.

STYLE B - indicates parts that are included in the box.

STYLE C - indicates parts that are already assembled from previous steps.

CHASSIS PREPARATION

To protect and seal edges of graphite parts, sand edges smooth and then apply CA glue.

Do this for: chassis edges, countersunk holes, and shock towers.

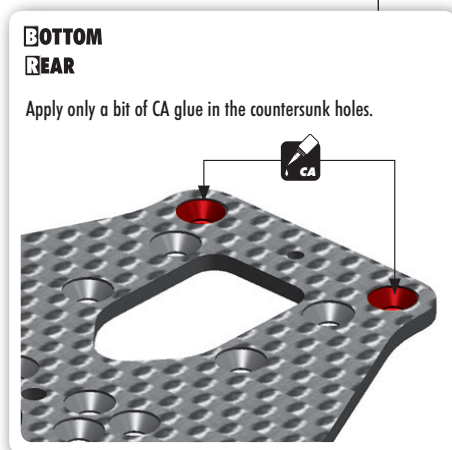
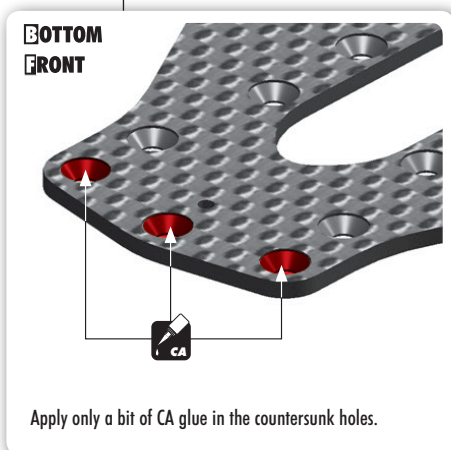
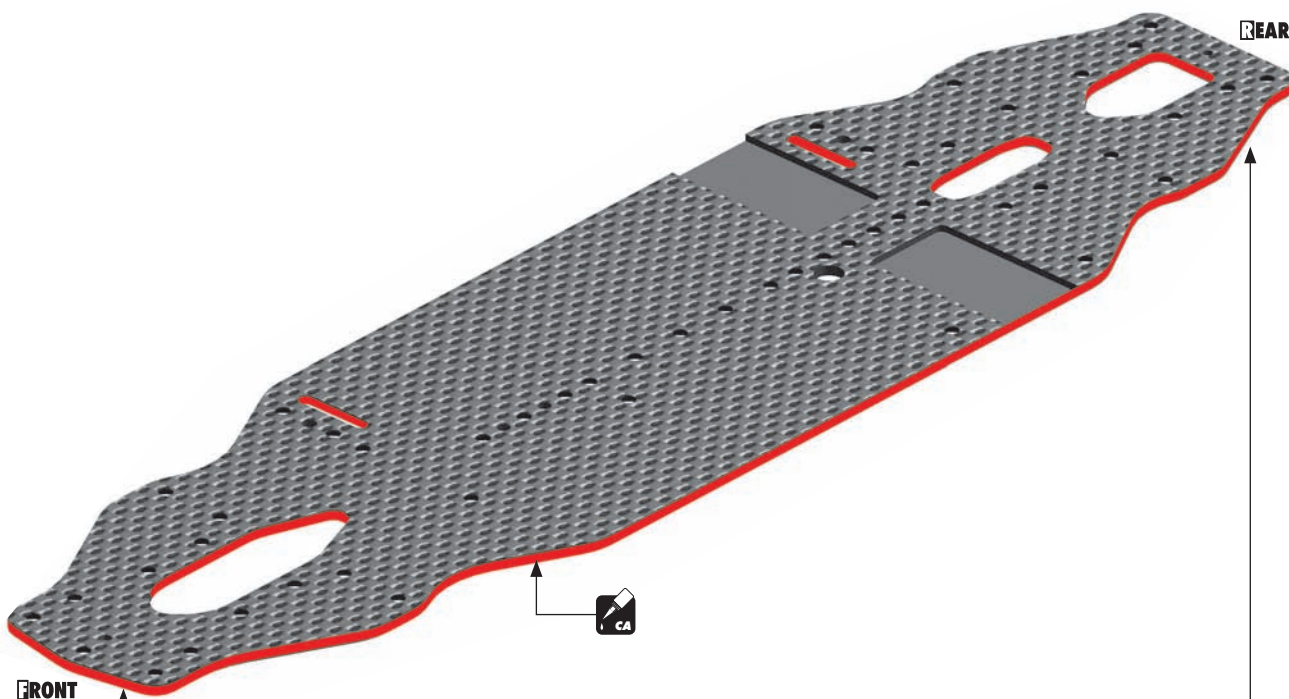

1. GEAR DIFFERENTIAL & FRONT SOLID AXLE

#304932
OPTION GRAPHITE GEAR DIFF BEVEL & SATELLITE GEARS (2+4)

#309002
OPTION SET OF CERAMIC BALL-BEARINGS (14)

01.2
GEAR DIFFERENTIAL

01.1
COMPOSITE SOLID AXLE

#304971
OPTION HUDY SPRING STEEL™ OUTDRIVES

#305136
OPTION ALU SOLID DRIVESHAFT ADAPTERS

#305137
OPTION STEEL SOLID AXLE DRIVESHAFT ADAPTERS HUDY SPRING STEEL™

BAG 01.1 01.2	30 4900	XRAY GEAR DIFFERENTIAL - SET	90 2310	HEX SCREW SH M3x10 (10)
	30 4910	COMPOSITE GEAR DIFF. CASE & COVER	90 3256	HEX SCREW SFH M2.5x6 (10)
	30 4930	COMPOSITE GEAR DIFF BEVEL & SATELLITE GEARS (2+4)	94 1015	HIGH-SPEED BALL-BEARING 10x15x4 RUBBER SEALED (2)
	30 4970	ALU GEAR DIFF OUTDRIVE ADAPTER - 7075 T6 (2)	96 4031	WASHER S 3.5x10x0.2 (10)
	30 4980	COMPOSITE GEAR DIFF CROSS PIN	96 4050	WASHER S 5x15x0.3 (10)
	30 4990	DIFF GASKET (4)	97 1240	SILICONE O-RING 24x0.7 (10)
	30 5105	XRAY MULTI-DIFF T3/T4 LiPo (OPTION)	97 2050	SILICONE O-RING 5x2 (10)
	30 5135	COMPOSITE SOLID AXLE DRIVESHAFT ADAPTERS (2)	98 1210	PIN 2x10 (10)
	30 5188	COMPOSITE SOLID AXLE 38T - SET		

964050
S 5x15x0.3

972050
O 5x2

981210
P 2x10

STEP 4 5 DETAIL

#304971
OPTION HUDY SPRING STEEL™ OUTDRIVES

#304932
OPTION GRAPHITE GEAR DIFF BEVEL & SATELLITE GEARS (2+4)

964050
S 5x15x0.3

972050
O 5x2

981210
P 2x10

NOTE ORIENTATION

STEP 4 DETAIL
Use tweezers to insert pin.

CUTAWAY VIEW

1. GEAR DIFFERENTIAL & FRONT SOLID AXLE



964031
S 3.5x10x0.2

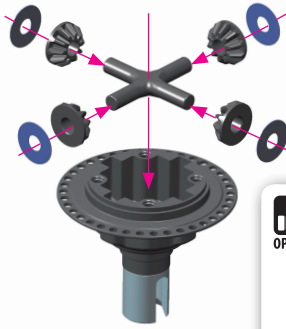

OPTION #304932
GRAPHITE GEAR DIFF BEVEL &
SATELLITE GEARS (2+4)

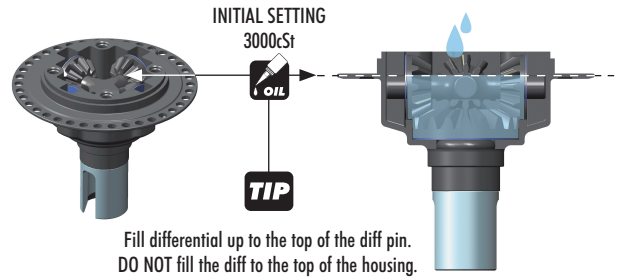

INITIAL SETTING
3000cSt
TIP
Fill differential up to the top of the diff pin.
DO NOT fill the diff to the top of the housing.

TO ENSURE YOU HAVE THE SAME AMOUNT OF OIL FROM REBUILD TO REBUILD, DO THE FOLLOWING:



7.90g

#107865
HUDY Ultimate Digital Pocket
Scale 300g ± 0.01g



9.40g

1 Put the diff (without oil) on the scale and check the weight (approximately 7.90g)

$$7.9g + 1.5g = 9.4g$$

2 Slowly pour oil into the diff and watch the weight. Add 1.5g of oil into the diff. The approximate weight of the diff including oil is 9.40g.

TIP

TIPS FOR DIFFERENTIALS

TIP

LOW TRACTION

1000cSt (HUDY #106410)
2000cSt (HUDY #106420)

MEDIUM TRACTION

2000cSt (HUDY #106420)
3000cSt (HUDY #106430)
4000cSt (HUDY #106440)
5000cSt (HUDY #106450)

HIGH TRACTION

5000cSt (HUDY #106450)
6000cSt (HUDY #106460)
7000cSt (HUDY #106470)
8000cSt (HUDY #106480)
9000cSt (HUDY #106490)
10000cSt (HUDY #106510)

SUPER-HIGH TRACTION

10000cSt (HUDY #106510)
15000cSt (HUDY #106515)
20000cSt (HUDY #106520)

NOTE

SOFTER oil increases rear traction, HARDER oil increases on-power steering and stability. It is important not to use soft oils in high-traction conditions as this would not increase traction, but would make the car loose as the car would become too twitchy.

However, if the oil is too soft, it could generate the same effect like the car has no traction. Therefore it is very important to choose the correct oil very carefully. We recommend using softer oil first, then try harder oil to better understand the effect on the car's behavior at the track. Choose the oil accordingly.

TIP TIPS FOR FRONT DIFFERENTIAL

To increase on-power steering and cornering speed, the gear diff can also be used in the front. **NOTE:** If you use the gear diff in the front, we recommend using optional #304971 HUDY Spring Steel™ outrdrives because the stress on the outrdrives in the front is much higher than in the rear.

USE THESE OILS FOR FRONT DIFFERENTIAL

500,000 cSt (HUDY #106650)
1,000,000 cSt (HUDY #106692)
2,000,000 cSt (HUDY #106694)

To make the front differential tighter, you can use cleaning gum instead of oil.

IMPORTANT!

Using cleaning gum instead of oil in the gear differential can lead to gear breakage because the gears are working under dry conditions.

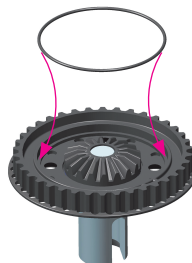
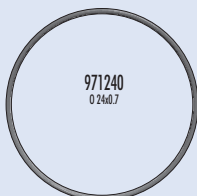

After disassembling the gear diff the large O-ring may have an increased size and may be more difficult to re-install. We recommend either inserting the old O-ring carefully in the diff cover, or replacing the old O-ring with a new O-ring if the old one cannot be made to fit properly.

1. GEAR DIFFERENTIAL & FRONT SOLID AXLE

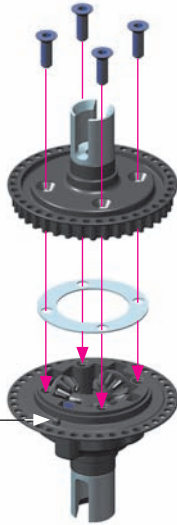
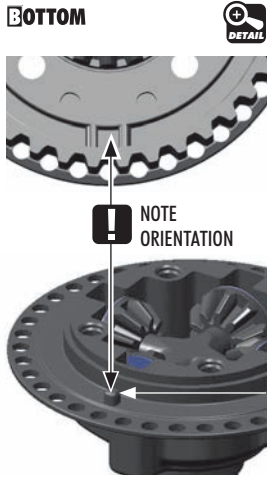

Tighten the screws equally but do NOT tighten them completely.

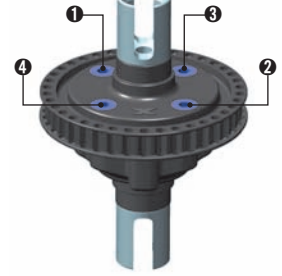

Finish tightening in this order.

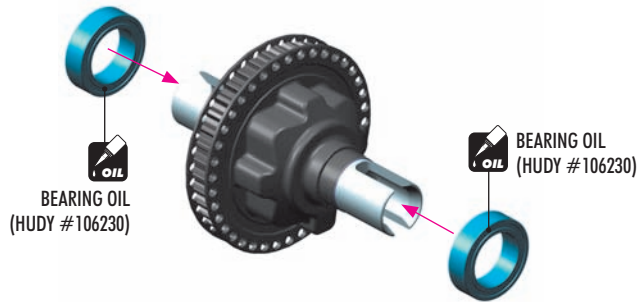

COMPOSITE FRONT SOLID AXLE

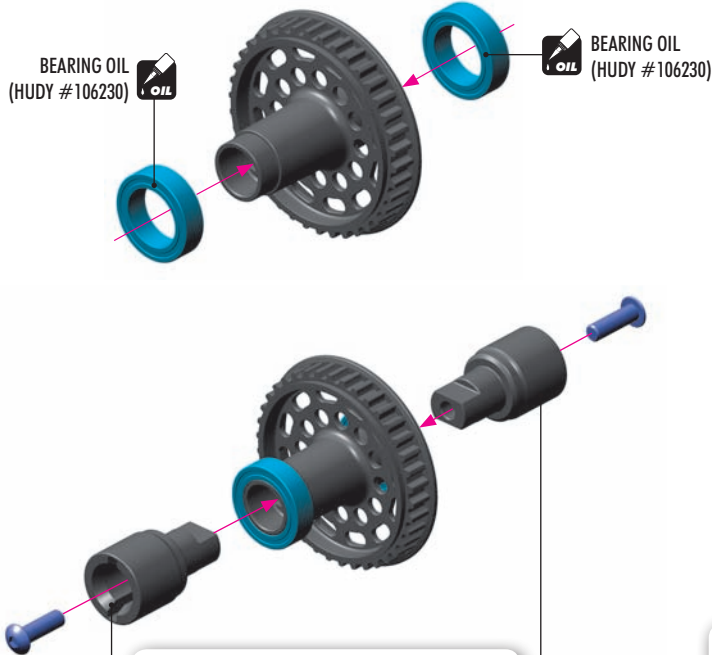

OPTION #305137
STEEL SOLID AXLE DRIVESHAFT ADAPTERS
HUDY SPRING STEEL™



OPTION #305136
ALU SOLID DRIVESHAFT ADAPTERS



CUTAWAY VIEW

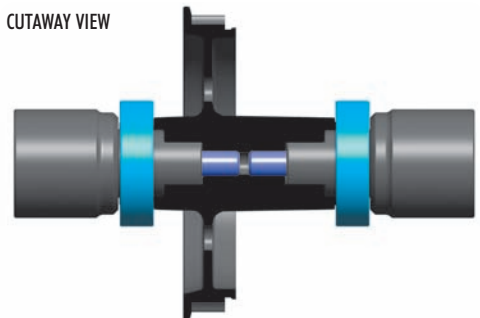

FRONT & REAR AXLES

2. CENTRAL TRANSMISSION

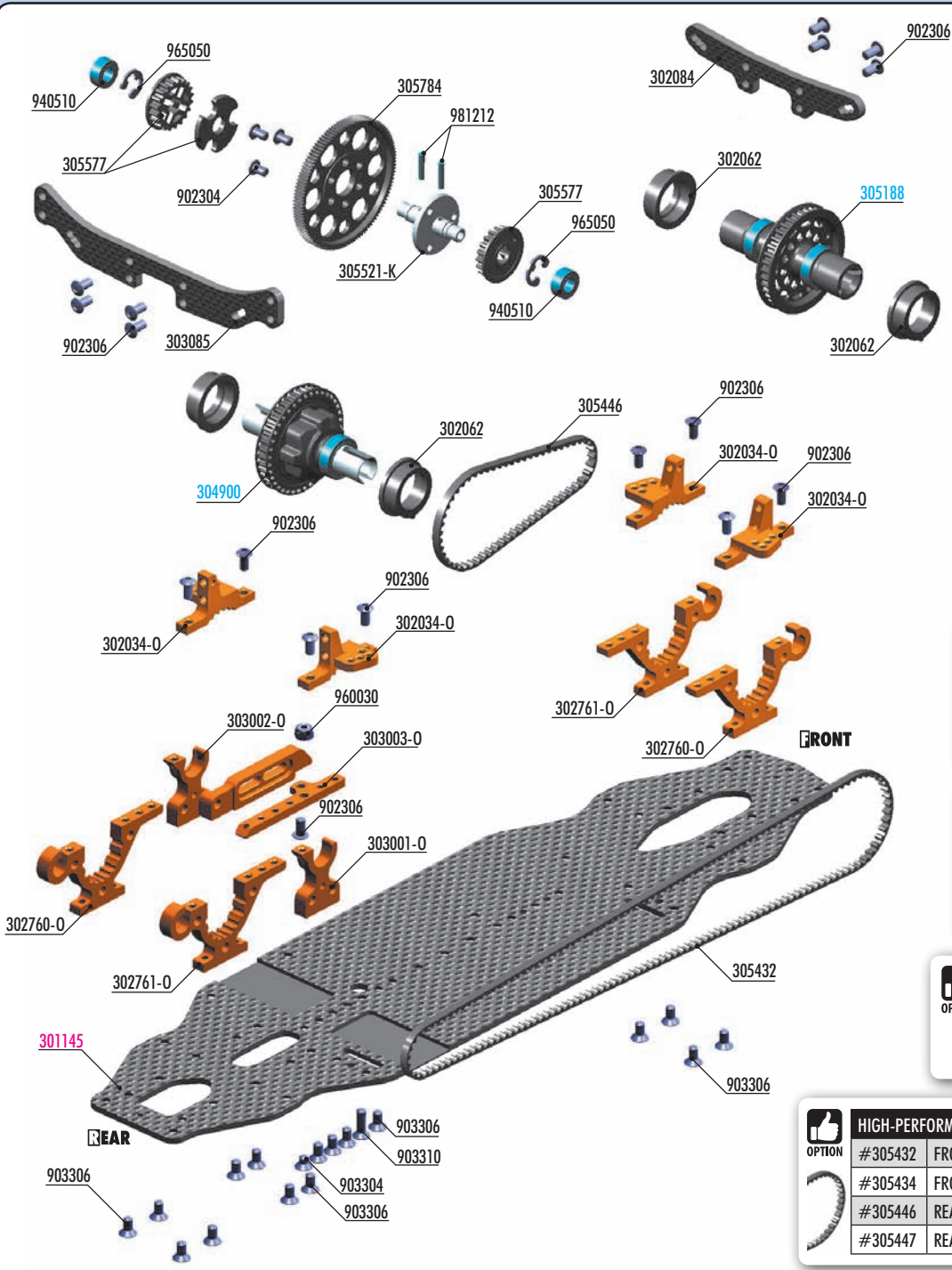

OFFSET SPUR GEARS 48P

#305772	72T / 48P	OPTION
#305776	76T / 48P	OPTION
#305778	78T / 48P	OPTION
#305779	79T / 48P	OPTION
#305781	81T / 48P	OPTION
#305784	84T / 48P	INCLUDED

OFFSET SPUR GEARS 64P

#305860	90T / 64P	OPTION
#305862	92T / 64P	OPTION
#305866	96T / 64P	OPTION
#305869	99T / 64P	OPTION
#305870	100T / 64P	OPTION
#305874	104T / 64P	OPTION
#305876	106T / 64P	OPTION
#305878	108T / 64P	OPTION
#305880	110T / 64P	OPTION
#305882	112T / 64P	OPTION
#305884	114T / 64P	OPTION

#30902
SET OF CERAMIC BALL-BEARINGS (14)

#303004
T4'18 BRASS MOTOR MOUNT PLATE

#302063
ALU ADJUSTMENT BALL-BEARING HUB (2)

HIGH-PERFORMANCE KEVLAR® DRIVE BELT

#305432	FRONT 3 x 513 MM	STANDARD	INCLUDED
#305434	FRONT 3 x 513 MM	LOW-FRICTION	OPTION
#305446	REAR 3 x 189 MM	STANDARD	INCLUDED
#305447	REAR 3 x 189 MM	LOW-FRICTION	OPTION

#303071
BELT TENSIONER SET

#301147
T4'18 ALU FLEX CHASSIS 2.0MM

#301146
T4'18 ALU CHASSIS 2.0MM

BAG
02

- 30 2034-O T4 ALU UPPER CLAMP WITH 5 ADJ. ROLL-CENTERS (L+R) - ORANGE
- 30 2062 T4 COMPOSITE ADJUSTMENT BALL-BEARING HUB (4)
- 30 2084 ULP SHOCK TOWER FRONT 3.0MM GRAPHITE
- 30 2760-O T4 ALU LOWER ADJUSTMENT BULKHEAD - FRONT R / REAR L - ORANGE
- 30 2761-O T4 ALU LOWER ADJUSTMENT BULKHEAD - FRONT L / REAR R - ORANGE
- 30 3001-O T4'18 ALU LAYSHAFT BULKHEAD RIGHT - ORANGE
- 30 3002-O T4'18 ALU MOTOR MOUNT - ORANGE
- 30 3003-O T4'18 ALU MOTOR MOUNT PLATE - ORANGE
- 30 3085 ULP SHOCK TOWER REAR 3.0MM GRAPHITE
- 30 5432 HIGH-PERFORMANCE KEVLAR® DRIVE BELT FRONT 3 x 513 MM
- 30 5446 HIGH-PERFORMANCE KEVLAR® DRIVE BELT REAR 3 x 189 MM
- 30 5521-K ALU SOLID LAYSHAFT - BLACK
- 30 5577 COMPOSITE FIXED PULLEY 20T (2)
- 30 5784 SPUR GEAR 84T / 48

- 90 2304 HEX SCREW SH M3x4 - STAINLESS (10)
- 90 2306 HEX SCREW SH M3x6 (10)
- 90 3304 HEX SCREW SFH M3x4 (10)
- 90 3306 HEX SCREW SFH M3x6 (10)
- 90 3310 HEX SCREW SFH M3x10 (10)
- 94 0510 HIGH-SPEED BALL-BEARING 5x10x4 RUBBER SEALED (2)
- 96 0030 NUT M3 (10)
- 96 5050 E-CLIP 5 (10)
- 98 1212 PIN 2x12 (10)

- 30 4900 XRAY GEAR DIFFERENTIAL - SET
- 30 5188 COMPOSITE SOLID AXLE 38T - SET
- 30 1145 T4'18 CHASSIS 2.2MM GRAPHITE

2. CENTRAL TRANSMISSION

902306
SH M3x6

903304
SFH M3x4

903306
SFH M3x6

903310
SFH M3x10

960030
N M3

NOTE ORIENTATION

! Do not tighten fully yet, the nut will be tightened after the motor mount is mounted on the chassis.

NOTE ORIENTATION

! IMPORTANT!
Tighten screws in order indicated. M3 nut must always be tightened fully. When tightening the nut, use pliers.

The front screw improves steering response and in-corner steering. Recommended for medium-high traction tracks.

The back screws generates more traction and makes the car more stable in the chicanes. Recommended for low-medium traction tracks.

FRONT **REAR**

Do not tighten fully

SH M3x6 **3**

#303004
T4'18 BRASS MOTOR MOUNT PLATE
OPTION



902304
SH M3x4

965050
CS

981212
P 2x12

CUTAWAY VIEW

NOTE ORIENTATION
only when using XRAY OFFSET spur gears.

1. **2.** **3.**

OFFSET SPUR GEARS 48P

#305772	72T	OPTION
#305776	76T	OPTION
#305778	78T	OPTION
#305779	79T	OPTION
#305781	81T	OPTION
#305784	84T	INCLUDED

OFFSET SPUR GEARS 64P

#305860	90T	OPTION
#305862	92T	OPTION
#305866	96T	OPTION
#305869	99T	OPTION
#305870	100T	OPTION
#305874	104T	OPTION
#305876	106T	OPTION
#305878	108T	OPTION
#305880	110T	OPTION
#305882	112T	OPTION
#305884	114T	OPTION

940510
BB 5x10x4

NOTE ORIENTATION

! BEARING OIL (HUDY #106230)

Short belt Long belt

LONGER SHORTER

FRONT **REAR**

NOTE ORIENTATION

!

#302063
ALU ADJUSTMENT BALL-BEARING HUB (2)
OPTION

2. CENTRAL TRANSMISSION

FRONT BELT TENSION ADJUSTMENT

Front diff **UPPER** position - tab in bottom notch - provides **more steering**, but **less front traction**

Recommended for **medium-high** traction tracks and technical tracks.

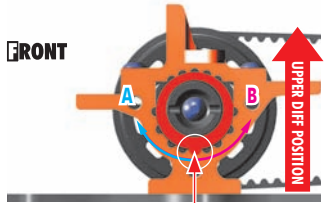

INITIAL POSITION FOR CARPET
Place tab in this **BOTTOM NOTCH**

TO LOOSEN FRONT BELT: Rotate both front nylon hubs in arrow direction **A**

TO TIGHTEN FRONT BELT: Rotate both front nylon hubs in arrow direction **B**

Front diff **LOWER** position - tab in top notch - provides **more front traction**, but makes the car **push more on power**.

Recommended for **low-traction** tracks.

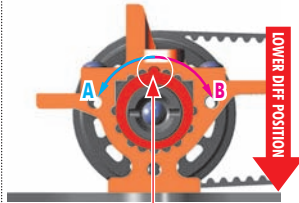

INITIAL POSITION FOR ASPHALT
Place tab in this **TOP NOTCH**

REAR BELT TENSION ADJUSTMENT

Rear diff **UPPER** position - tab in bottom notch - provides **more on-power steering**, but makes the rear slightly **more loose**.

Recommended for **medium-high** traction tracks.

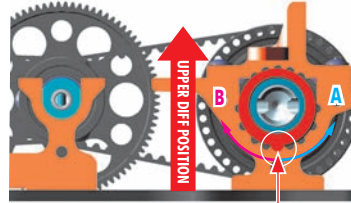

INITIAL POSITION FOR CARPET
Place tab in this **BOTTOM NOTCH**

TO LOOSEN REAR BELT: Rotate both rear nylon hubs in arrow direction **A**

TO TIGHTEN REAR BELT: Rotate both rear nylon hubs in arrow direction **B**

Rear diff **LOWER** position - tab in top notch - provides **more rear traction** (mainly on-power), makes the car **more stable in chicanes**, but makes the car **push on-power**.

Recommended for **low-medium** traction tracks.

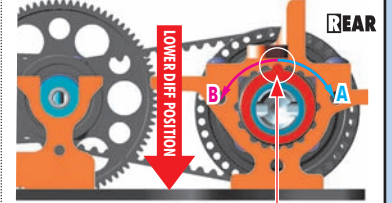

INITIAL POSITION FOR ASPHALT
Place tab in this **TOP NOTCH**

#303071 BELT TENSIONER SET

May be used when the front belt becomes worn and loose. Belt tensioner is **NOT** included in the kit and must be purchased separately.

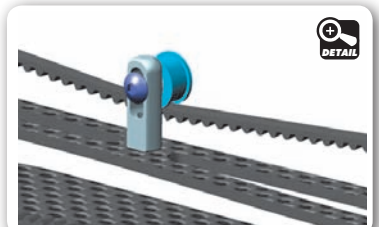
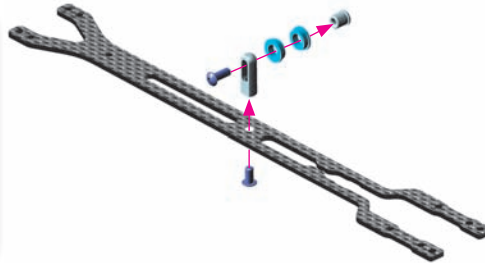

902306 SH M3x6

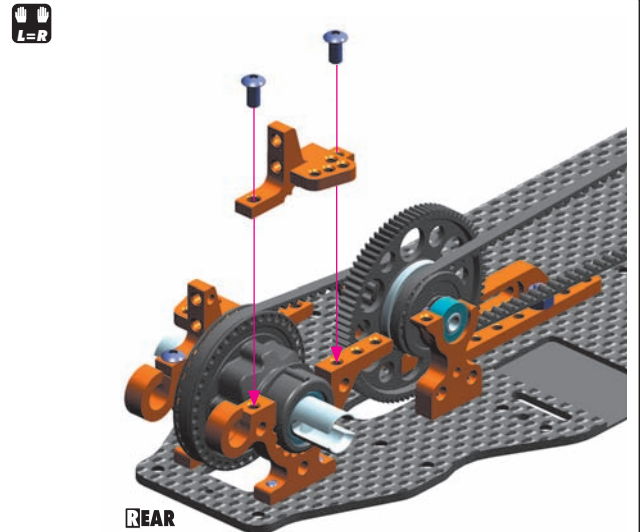
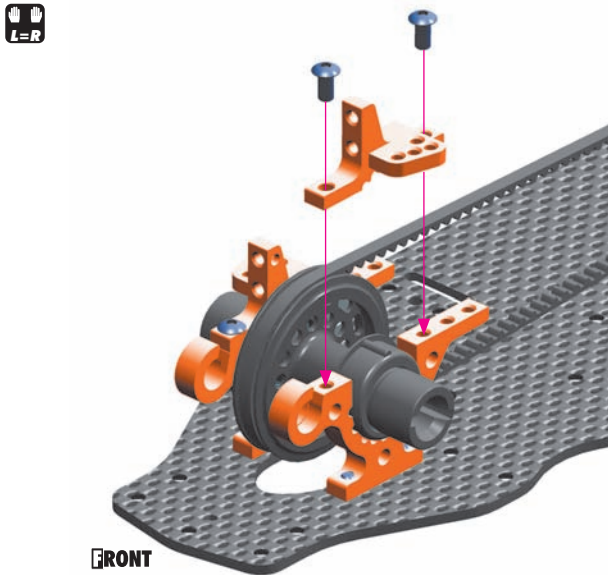

902306 SH M3x6

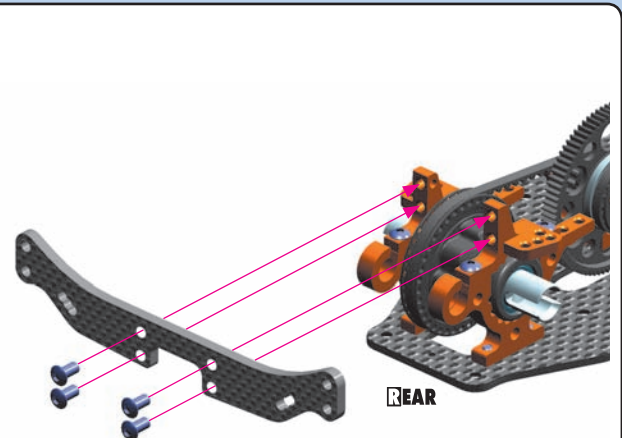
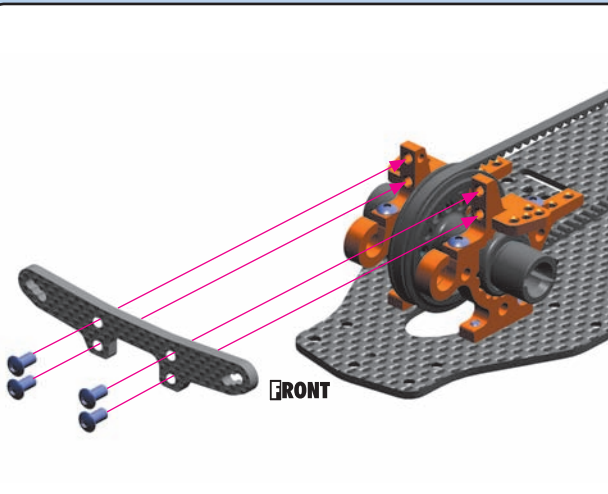

3. FRONT & REAR SUSPENSION

REAR ARMS - STANDARD

#303168	HARD	OPTION
#303169	GRAPHITE	INCLUDED

REAR ARMS - ARS™

#303170	HARD	INCLUDED
#303171	GRAPHITE	OPTION

FOR ALTERNATIVE SETTING ACTIVE REAR SUSPENSION™

08 BAG

#303170

OPTION

#307217 TITANIUM SUSPENSION PIVOT PIN (2)

OPTION

FRONT ARMS		
#302168	HARD	OPTION
#302169	GRAPHITE	INCLUDED

OPTION

#302712-0 ALU FRONT 1-PIECE SUSPENSION HOLDER (FF-LOW)
#302722-0 ALU FRONT 1-PIECE SUSPENSION HOLDER (FR-LOW)

OPTION

#302711 BRASS FRONT 1-PIECE SUSPENSION HOLDER - FRONT - FF
#302721 BRASS FRONT 1-PIECE SUSPENSION HOLDER - REAR - FR
#303714 BRASS 2-PIECE SUSPENSION HOLDER - RIGHT
#303715 BRASS 2-PIECE SUSPENSION HOLDER - LEFT
#303721 BRASS REAR 1-PIECE SUSPENSION HOLDER - REAR - RR

OPTION For better stability and to make the car easier to drive, optional #302190 and #303190 graphite stiffeners may be used on the suspension arms. Using only 4 screws, each graphite stiffener can be installed or removed which will completely change the characteristics of the car. Stiffeners may be used independently at front and/or rear. **IMPORTANT!** Install/remove stiffeners equally on left & right sides.

#30 2190
GRAPHITE FRONT LOWER ARM PLATE 1.6MM (2)

2x

2.5x6mm

FRONT

#30 3190
GRAPHITE REAR LOWER ARM PLATE 1.6MM (2)

2x

2.5x6mm

REAR

STANDARD REAR SUSPENSION

#30 3192
ARS GRAPHITE REAR LOWER ARM PLATE 1.6MM (2)

2x

2.5x6mm

REAR

ACTIVE REAR SUSPENSION™

BAG 03

<p>30 2169 FRONT SUSPENSION ARM - GRAPHITE - 1-HOLE</p> <p>30 2710-0 ALU FRONT LOWER 1-PIECE SUSPENSION HOLDER - FRONT - FF</p> <p>30 2720-0 ALU FRONT LOWER 1-PIECE SUSPENSION HOLDER - REAR - FR</p> <p>30 3129 COMPOSITE SET OF WHEELBASE SHIMS (3x1MM; 1x2MM) (2)</p> <p>30 3169 REAR SUSPENSION ARM - GRAPHITE - 1-HOLE</p> <p>30 3170 ARS - ACTIVE REAR SUSPENSION ARM - HARD - 1-HOLE</p> <p>303712-0 ALU LOWER 2-PIECE SUSPENSION HOLDER - RIGHT</p> <p>303713-0 ALU LOWER 2-PIECE SUSPENSION HOLDER - LEFT</p>	<p>30 3711-0 ALU REAR LOWER 1-PIECE SUSPENSION HOLDER - FRONT - RF (OPTION)</p> <p>30 3720-0 ALU REAR LOWER 1-PIECE SUSPENSION HOLDER - REAR - RR</p> <p>30 7216 SUSPENSION PIVOT PIN (2)</p> <p>36 2315 ECCENTRIC BUSHING SET (2)</p> <p>90 1308 HEX SCREW SB M3x8 (10)</p> <p>90 1310 HEX SCREW SB M3x10 (10)</p> <p>90 1408 HEX SCREW SB M4x8 (10)</p> <p>90 3306 HEX SCREW SFH M3x6 (10)</p>	
---	--	--

3. FRONT & REAR SUSPENSION



901310
SB M3x10



901408
SB M4x8

2x L=R REAR ARMS

STANDARD REAR SUSPENSION

(INITIAL SETTING)

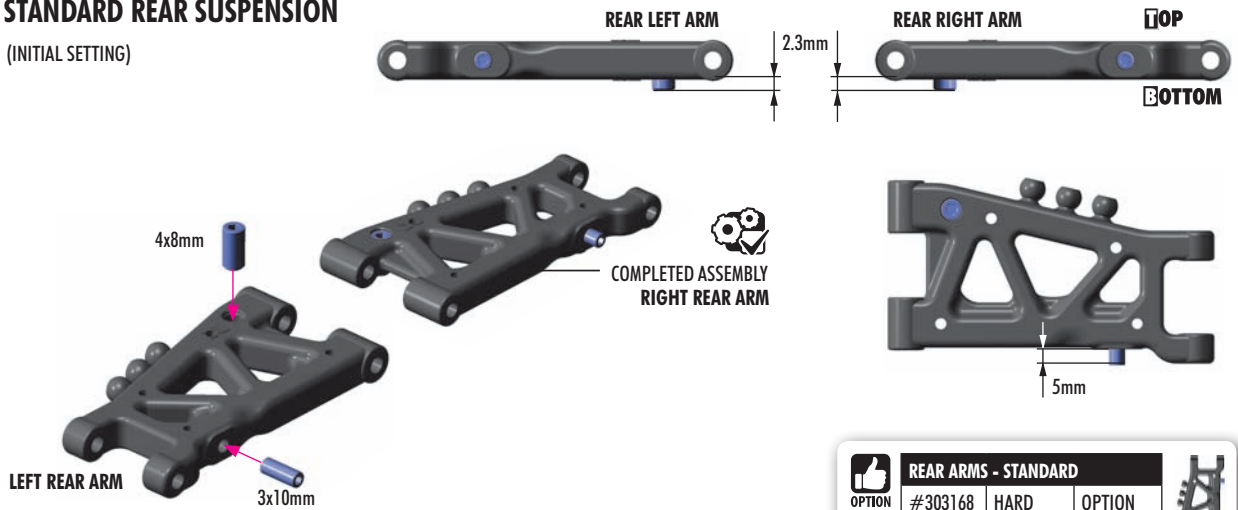

REAR ARMS - STANDARD			
OPTION	#303168	HARD	OPTION
	#303169	GRAPHITE	INCLUDED
REAR ARMS - ARS™			
	#303170	HARD	INCLUDED
	#303171	GRAPHITE	OPTION

2x L=R ACTIVE REAR SUSPENSION™

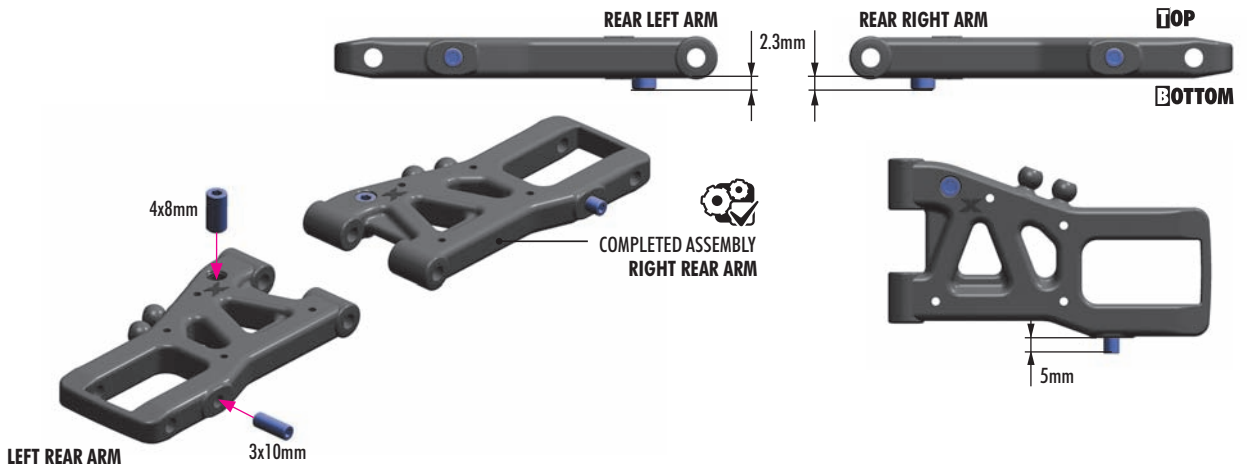

REAR DOWNSTOP
ADJUSTMENT



901308
SB M3x8



901408
SB M4x8

2x L=R FRONT ARMS

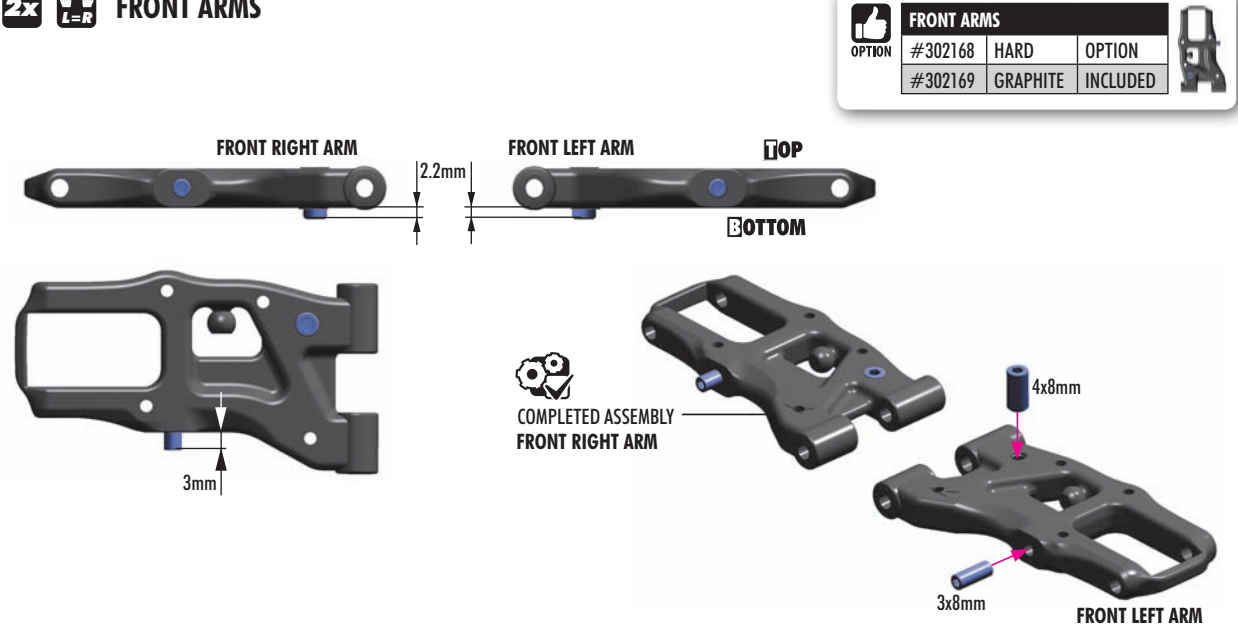

FRONT ARMS			
OPTION	#302168	HARD	OPTION
	#302169	GRAPHITE	INCLUDED



FRONT DOWNSTOP
ADJUSTMENT

3. FRONT & REAR SUSPENSION



903306
SFH M3x6

FRONT SUSPENSION

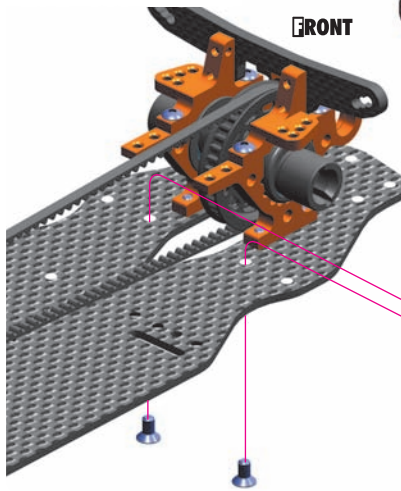

FRONT

Marked "FR"

! NOTE ORIENTATION



! #303710-0 ALU LOWER 2-PIECE SUSPENSION HOLDER
OPTION For more steering, we recommend using the optional alu separate suspension holders.

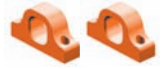

! #302721 BRASS FRONT 1-PIECE SUSPENSION HOLDER (FR)
OPTION



! #302722-0 ALU FRONT 1-PIECE SUSPENSION HOLDER (FR-LOW)
OPTION



303129
SHIM 3x6x1



903306
SFH M3x6

REAR SUSPENSION

! #303714 BRASS 2-PIECE SUSPENSION HOLDER - RIGHT
OPTION #303715 BRASS 2-PIECE SUSPENSION HOLDER - LEFT



! It is extremely important that the arms move freely on the pivot pins. If they do not, use the Arm Reamer (3.0mm) to slightly resize the holes in the arms.



#107633 HUDY Arm Reamer 3.0mm

! #303721 BRASS REAR 1-PIECE SUSPENSION HOLDER - (RR)
OPTION

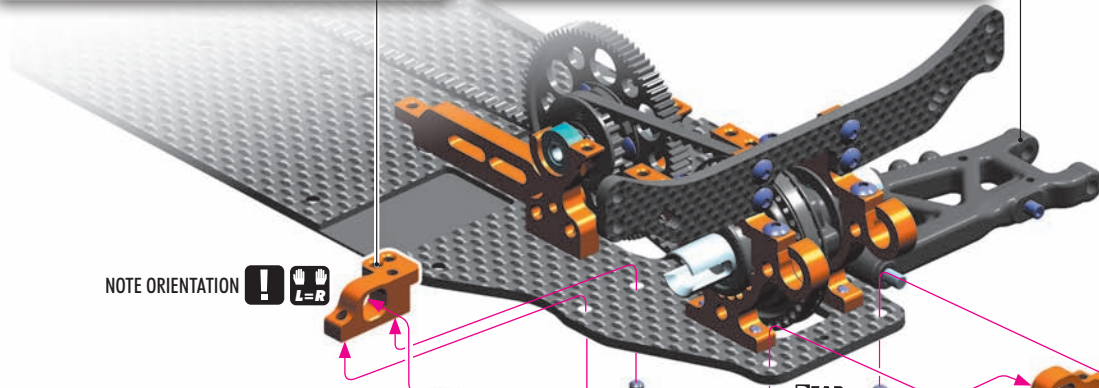

! NOTE ORIENTATION



Marked "RR"

INITIAL SETTING

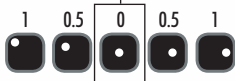

Composite eccentric bushings

ALTERNATIVE
STANDARD REAR SUSPENSION
(INITIAL SETTING)

ALTERNATIVE
ACTIVE REAR SUSPENSION™

3x6x1mm

Composite eccentric bushings

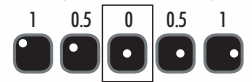

INITIAL SETTING

! #307217 TITANIUM SUSPENSION PIVOT PIN (2)
OPTION



ECCENTRIC BUSHINGS HAVE TWO DIFFERENT OFFSETS FROM THE CENTER

- Middle position = 0.5 mm or 0.5° from center
- Outer position = 1 mm or 1° from center

The XRAY rear alu lower suspension holders provide even greater range of adjustment for the rear suspension. Using different combinations of eccentric bushings, fine adjustment of rear squat, rear toe-in, rear roll center, and rear track-width can be obtained. For more information about the influence of rear squat, rear toe-in, rear roll center and rear track-width on car handling, please refer to HUDY Set-up Book (#209100).

All possible mounting alternatives of eccentric bushings

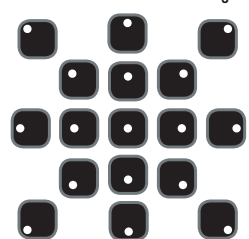

TOE-IN
TRACK-WIDTH
WHEELBASE
ROLL CENTER
ANTI-SQUAT
PRO-SQUAT

3. FRONT & REAR SUSPENSION

10

303129
SHIM 3x6x1



903306
SFH M3x6

FRONT SUSPENSION



#302711
BRASS FRONT 1-PIECE SUSPENSION HOLDER - (FF)



#302712-0
ALU FRONT 1-PIECE SUSPENSION HOLDER (FF-LOW)

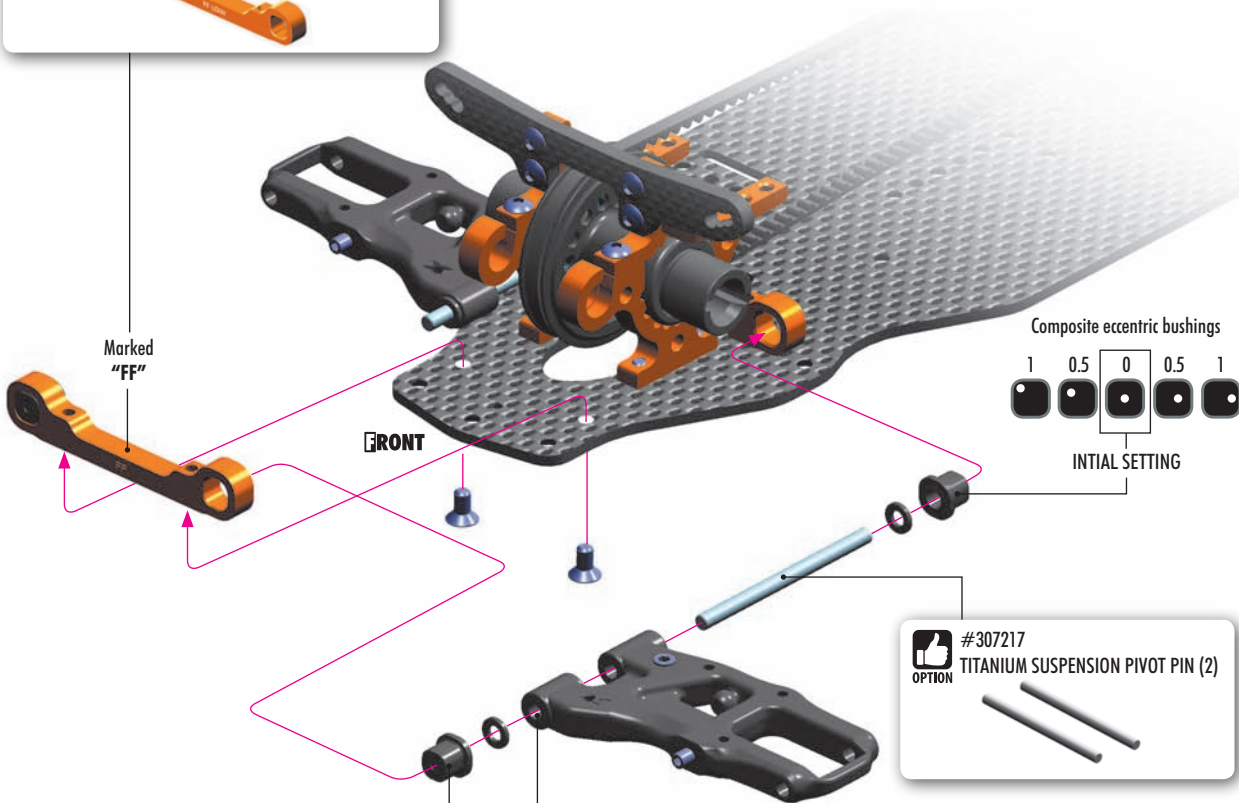

Marked "FF"

FRONT

Composite eccentric bushings

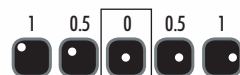

INITIAL SETTING



#307217
TITANIUM SUSPENSION PIVOT PIN (2)



INITIAL SETTING



Composite eccentric bushings

All possible mounting alternatives of eccentric bushings

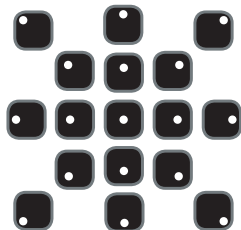

eccentric bushings have two different offsets from the center.

Middle position = 0.5 mm or 0.5° from center

Outer position = 1mm or 1° from center

The XRAY front alu lower suspension holders provide even greater range of adjustment for the front suspension. Using different combinations of eccentric bushings, fine adjustment of front anti-squat, front kick-up, front toe-in, front roll center, and front track-width can be obtained. For more information about the influence of front anti-dive, front kick-up, front toe-in, front roll center and front track-width on car handling, please refer to HUDY Set-up Book (#209100).



It is extremely important that the arms move freely on the pivot pins. If they do not, use the Arm Reamer (3.0mm) to slightly resize the holes in the arms.

#107633 HUDY Arm Reamer 3.0mm



TOE-IN
TRACK-WIDTH
WHEELBASE
ROLL CENTER
ANTI-DIVE
KICK-UP

4. STEERING

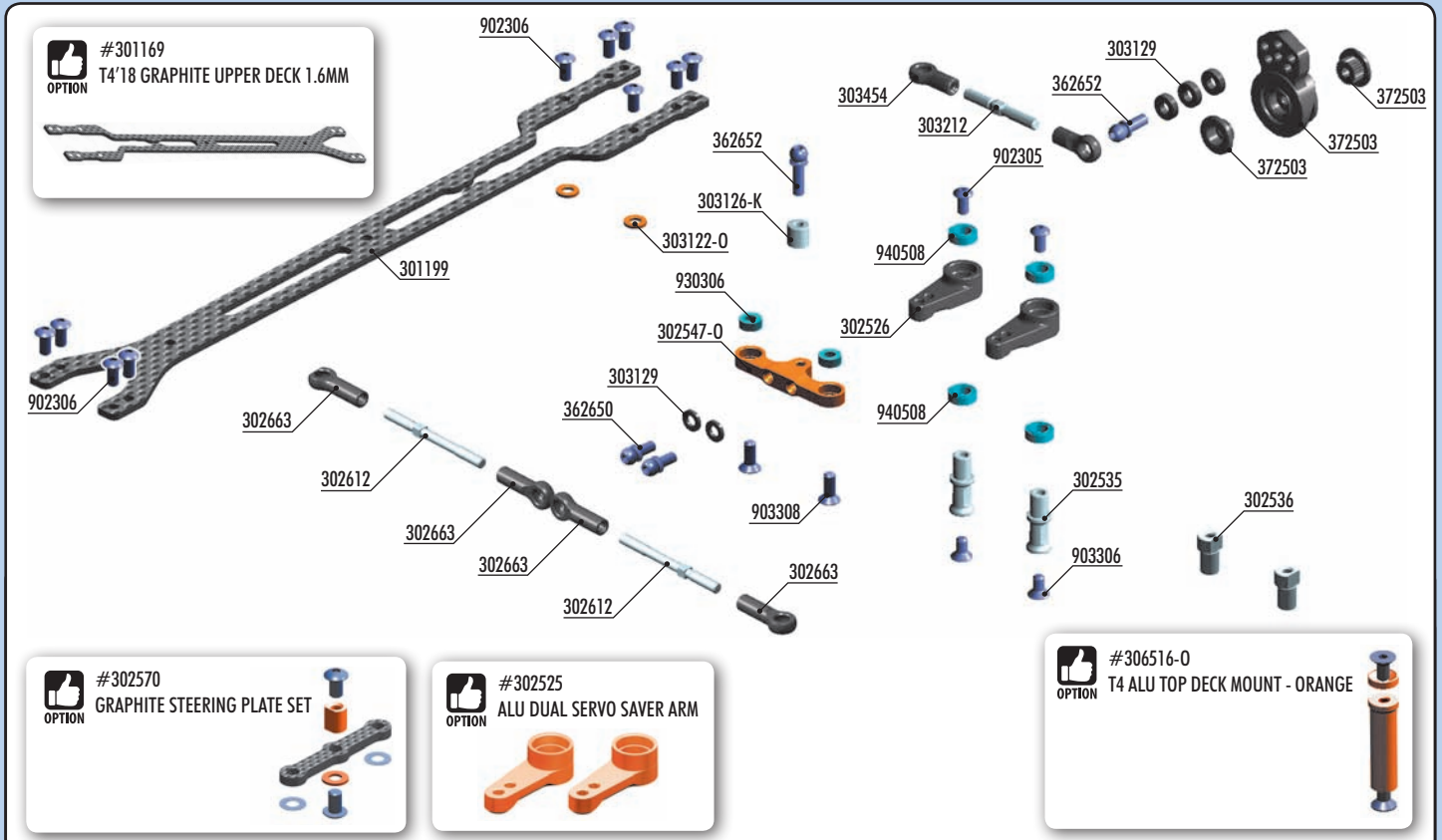

BAG
04

30 1199	T4'18 UPPER DECK 2.0MM GRAPHITE	30 3454	BALL JOINT 4.9MM - OPEN (4)
30 2526	COMPOSITE DUAL SERVO SAVER ARM	36 2650	BALL END 4.9MM WITH THREAD 6MM (2)
30 2535	ALU STEERING POST FOR DUAL SERVO SAVER (2)	36 2652	BALL END 4.9MM WITH THREAD 10MM (2)
30 2536	ALU STEERING POST FOR FLOATING SERVO SAVER (2)	37 2503	COMPOSITE SERVO SAVER - X-STIFF - SET - V2
30 2547-0	T4'14 ALU STEERING PLATE 8.5MM FOR DUAL SERVO SAVER - ORANGE	90 2305	HEX SCREW SH M3x5 (10)
30 2612	ALU ADJ. TURNBUCKLE M3 L/R 39 MM - SWISS 7075 T6 (2)	90 2306	HEX SCREW SH M3x6 (10)
30 2663	COMPOSITE BALL JOINT 5 MM - OPEN - V2 (8)	90 3306	HEX SCREW SFH M3x6 (10)
30 3122-0	ALU SHIM 3x6x1.0MM - ORANGE (10)	90 3308	HEX SCREW SFH M3x8 (10)
30 3126-K	ALU SHIM 3x6x5.0MM - BLACK (10)	93 0306	BALL-BEARING 3x6x2.5 (2)
30 3129	COMPOSITE SET OF SHIMS (3x1MM; 1x2MM) (2)	94 0508	HIGH-SPEED BALL-BEARING 5x8x2.5 RUBBER SEALED (2)
30 3212	ALU ADJ. TURNBUCKLE L/R 26 MM - SWISS 7075 T6 (2)		

SET-UP BOOK
FRONT TOE-IN

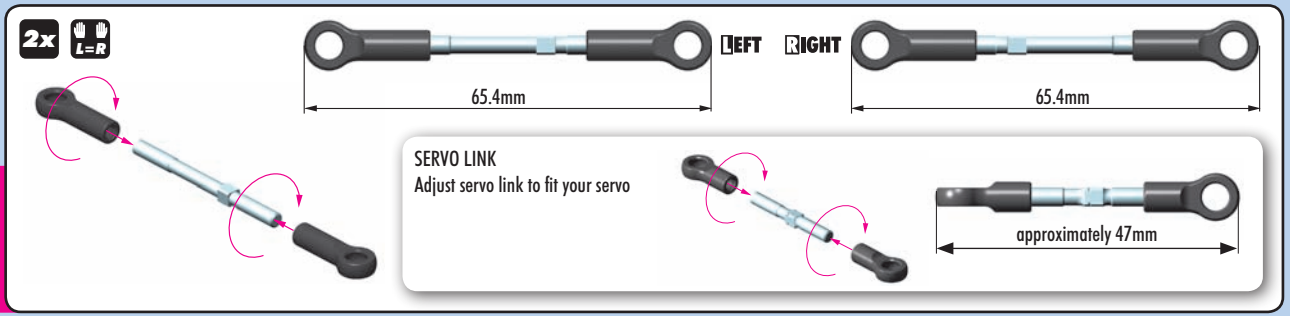

10

303129 SHIM 3x6x1

903308 SFH M3x8

930306 BB 3x6x2.5

940508 BB 5x8x2.5

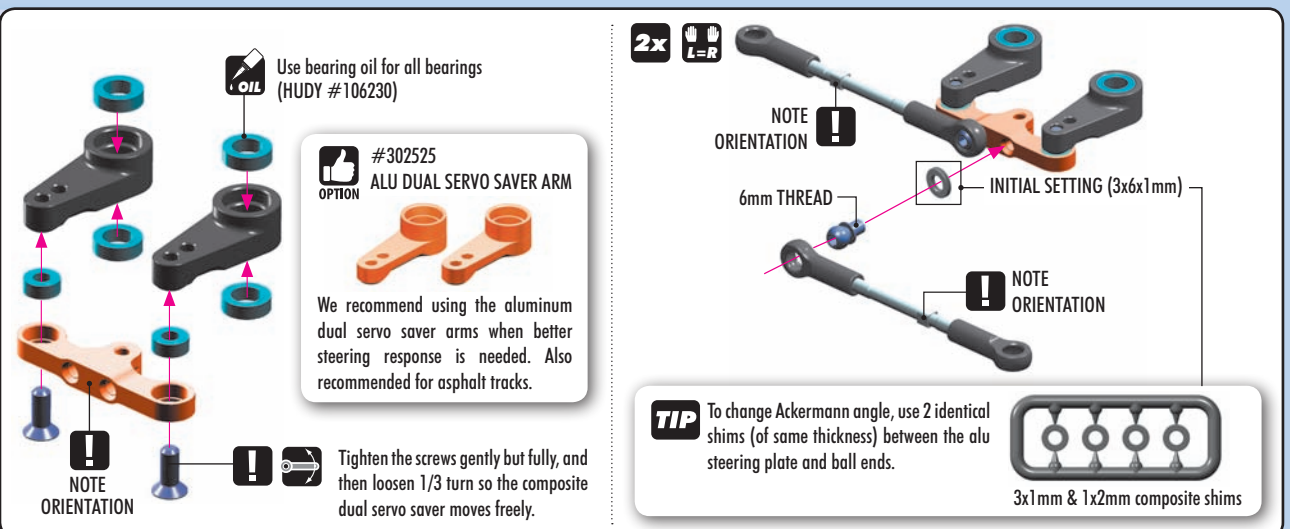



303129
SHIM 3x6x2



303126-K
SHIM 3x6x5

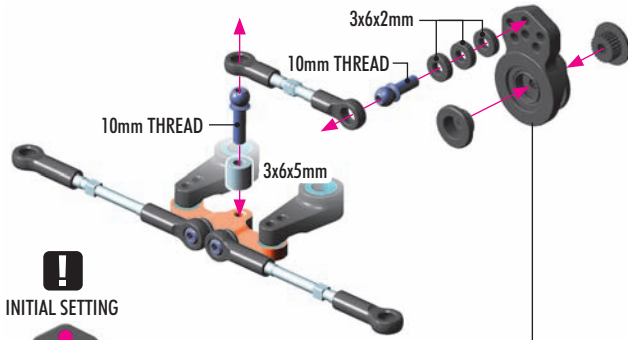

INITIAL SETTING

H = Hitec (24T)
F = Futaba, Robe (25T)
K = KO, JR, Airtronics, Sanwa (23T)



OPTION

HUDY ALU SERVO HORNS

#293491	KO, JR, Sanwa, Airtr. - OFFSET - 23T
#293492	Hitec - OFFSET - 24T
#293493	Futaba - OFFSET - 25T
#293501	KO, JR, Sanwa, Airtronics - 23T
#293502	Hitec - 24T
#293503	Futaba - 25T

For more in-corner steering and better steering response, aluminum servo horns may be used.

IMPORTANT!

When the aluminum horn is used, the steering servo saver is not used. This increases the risk of breaking the servo in serious crashes.

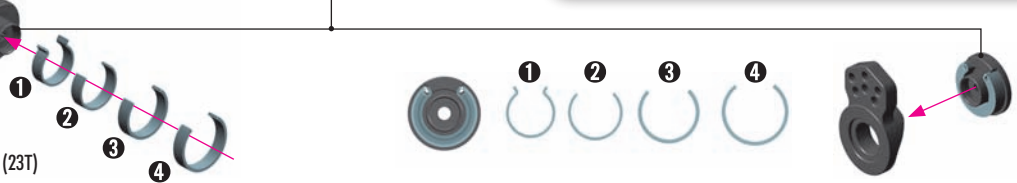

902305
SH M3x5



903306
SFH M3x6

ALTERNATIVE 1

STANDARD STEERING ARM MOUNTING (INITIAL SETTING)

Standard steering mounting system provides maximum steering response and makes steering more precise.

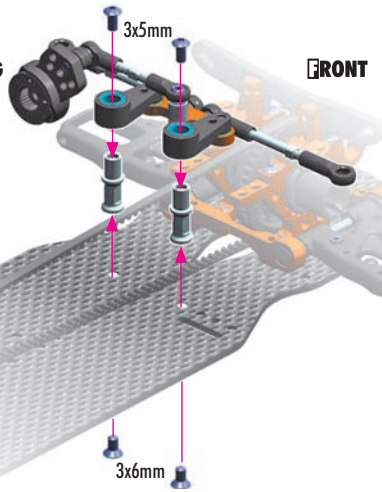

FRONT

ALTERNATIVE 2

FLOATING STEERING ARM MOUNTING

Floating steering mounting system makes the car easier to drive over curbs and on bumpy tracks. Helps prevent oversteer.

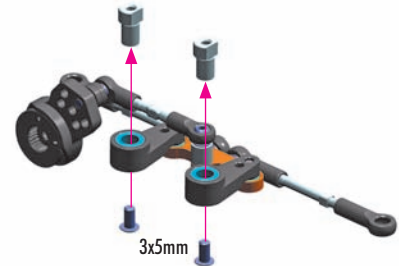

NOTE: The floating steering arms are mounted on the graphite servo holder in the Final Assembly page 33/step 1.



902306
SH M3x6



303122-0
SHIM 3x6x1

Do not use the layshaft screws for initial setting.

If the layshaft screws on the top deck are used, it is necessary to use also 3x6x1 shims under the top deck to connect top deck with layshaft bulkheads.

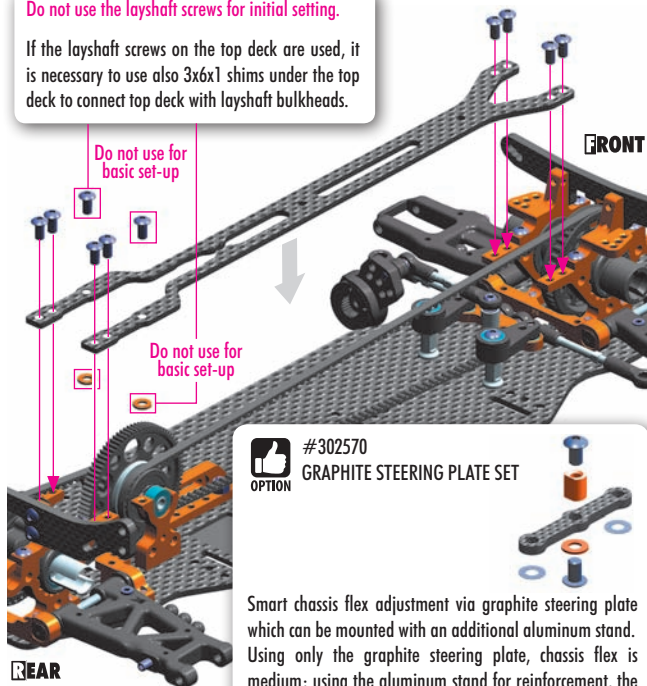

FRONT

REAR

#302570 GRAPHITE STEERING PLATE SET

Smart chassis flex adjustment via graphite steering plate which can be mounted with an additional aluminum stand. Using only the graphite steering plate, chassis flex is medium; using the aluminum stand for reinforcement, the flex becomes stiffer. Stiffer flex results in more aggressive handling and increased steering.



OPTION

#301169 T4'18 GRAPHITE UPPER DECK 1.6MM



We recommend using optional 1.6mm top deck for super-low traction conditions as it provides more overall traction and steering.



OPTION

#306516-0 T4 ALU TOP DECK MOUNT - ORANGE

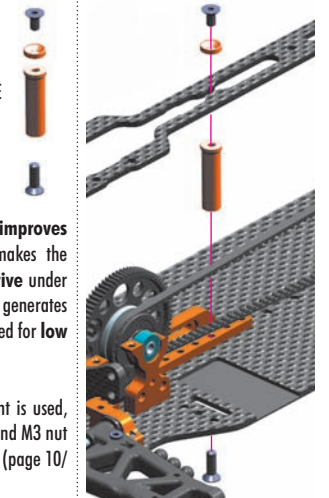

Optional alu top deck mount improves forward and rear traction and makes the car more stable and easier to drive under low-traction conditions, however generates more on-power push. Recommended for low and medium traction conditions.

When the aluminum top deck mount is used, the screws from layshaft bulkheads and M3 nut from motor holder must be removed (page 10/step 1).

SET-UP BOOK

CHASSIS FLEX SETTING
TOP DECK SETTING

5. FRONT & REAR TRANSMISSION

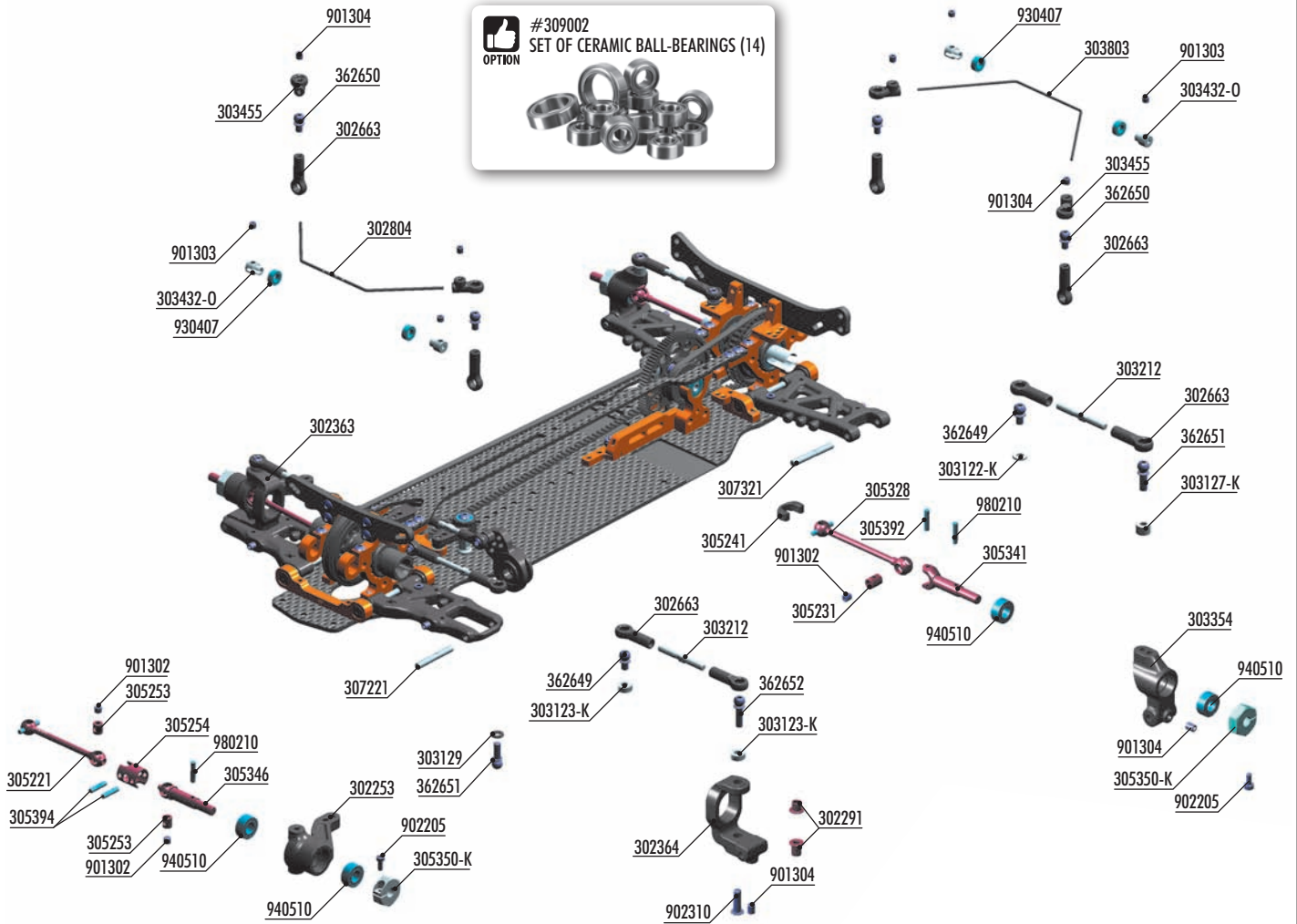

#309002
SET OF CERAMIC BALL-BEARINGS (14)
OPTION

#307222 TITANIUM FRONT ARM PIVOT PIN (2)
#307322 TITANIUM REAR ARM PIVOT PIN (2)
OPTION

#305242
DRIVE SHAFT REPLACEMENT CAP 3.5MM - ORANGE - STRONG (4)
OPTION

FOR ALTERNATIVE SETTING
ACTIVE REAR SUSPENSION™

BAG 08

BAG 05

- | | | | |
|-----------|---|-----------|--|
| 30 2253 | COMPOSITE STEERING BLOCK - HARD | 30 5328 | ALU DRIVE SHAFT SWISS 7075 T6 - HARDCOATED - 50MM |
| 30 2291 | STEEL STEERING BUSHING (2+2) | 30 5332 | ECS ES (ES) DRIVE SHAFT 52MM - HUDY SPRING STEEL™ - SET (OPTION) |
| 30 2363 | COMPOSITE C-HUB RIGHT - 4° DEG. - MEDIUM - V2 | 30 5333 | ECS ES (ES) DRIVE SHAFT 50MM - HUDY SPRING STEEL™ - SET (OPTION) |
| 30 2364 | COMPOSITE C-HUB LEFT - 4° DEG. - MEDIUM - V2 | 30 5334 | ECS ES (ES) DRIVE SHAFT 51MM - HUDY SPRING STEEL™ - SET |
| 30 2369 | COMPOSITE C-HUB RIGHT - 0° DEG. - HARD | 30 5346 | ECS DRIVE AXLE FOR 2MM PIN - HUDY SPRING STEEL™ |
| 30 2370 | COMPOSITE C-HUB LEFT - 0° DEG. - HARD | 30 5394 | ECS DRIVE SHAFT PIN 2 x 9 WITH FLAT SPOT (2) |
| 30 2663 | COMPOSITE BALL JOINT 4.9MM - OPEN - V2 (8) | 30 5341 | DRIVE AXLE - LIGHTWEIGHT - HUDY SPRING STEEL™ |
| 30 2804 | ANTI-ROLL BAR FOR BALL BEARINGS - FRONT 1.4 MM | 30 5350-K | ALU WHEEL HUB - BLACK (2) |
| 30 3122-K | ALU SHIM 3x6x1.0MM - BLACK (10) | 30 5392 | DRIVE SHAFT PIN 2 x 10 WITH FLAT SPOT (2) |
| 30 3123-K | ALU SHIM 3x6x2.0MM - BLACK (10) | 30 7221 | FRONT ARM PIVOT PIN (2) |
| 30 3127-K | ALU SHIM 3x6x4.0MM - BLACK (10) | 30 7321 | REAR ARM PIVOT PIN (2) |
| 30 3129 | COMPOSITE SET OF SHIMS (3x1MM; 1x2MM) (2) | 36 2649 | BALL END 4.9MM WITH THREAD 5MM (2) |
| 30 3210 | TURNBUCKLE M3 L/R 26 MM - HUDY SPRING STEEL™ (2) (OPTION) | 36 2650 | BALL END 4.9MM WITH THREAD 6MM (2) |
| 30 3212 | ALU ADJ. TURNBUCKLE M3 L/R 26 MM - SWISS 7075 T6 (2) | 36 2651 | BALL END 4.9MM WITH THREAD 8MM (2) |
| 30 3212-0 | ALU ADJ. TURNBUCKLE L/R 26 MM - ORANGE - SWISS 7075 T6 (2) (OPTION) | 36 2652 | BALL END 4.9MM WITH THREAD 10MM (2) |
| 30 3354 | COMPOSITE UPRIGHT 0° OUTBOARD TOE-IN - HARD | 90 1302 | HEX SCREW SB M3x2.5 (10) |
| 30 3432-0 | ALU ANTI-ROLL BAR BUSHING - ORANGE (2) | 90 1303 | HEX SCREW SB M3x3 (10) |
| 30 3455 | COMPOSITE ANTI-ROLL BAR BALL JOINT 4.9 MM (4) | 90 1304 | HEX SCREW SB M3x4 (10) |
| 30 3803 | ANTI-ROLL BAR FOR BALL BEARINGS - REAR 1.3 MM | 90 2205 | HEX SCREW SH M2x5 (10) |
| 30 5231 | DRIVE SHAFT COUPLING - HUDY SPRING STEEL™ | 90 2310 | HEX SCREW SH M3x10 (10) |
| 30 5241 | DRIVE SHAFT REPLACEMENT CAP 3.5 MM (4) | 93 0407 | BALL-BEARING 4x7x2.5 (2) |
| 30 5221 | ECS (ES) DRIVE SHAFT 51MM FOR 2MM PIN - HUDY SPRING STEEL™ (1) | 94 0510 | HIGH-SPEED BALL-BEARING 5x10x4 RUBBER SEALED (2) |
| 30 5253 | ECS DRIVE SHAFT COUPLING FOR 2MM PIN - HUDY SPRING STEEL™ | 98 0210 | PIN 2x10 (10) |
| 30 5254 | ECS (ES) DRIVE SHAFT CASE FOR 2MM PIN - HUDY SPRING STEEL™ | | |

5. FRONT & REAR TRANSMISSION



901302
SB M3x2.5

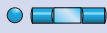

305392
P 2x10



305394
P 2x9

2x REAR TRANSMISSION

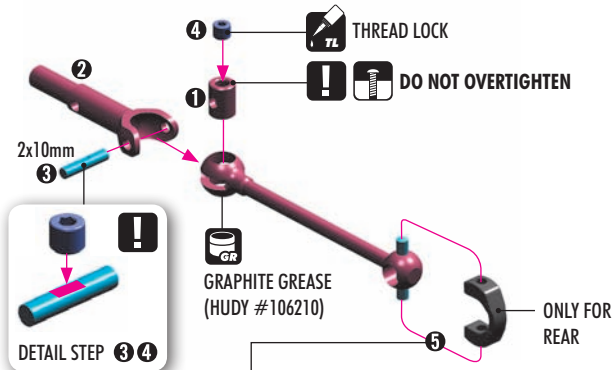

2x FRONT TRANSMISSION

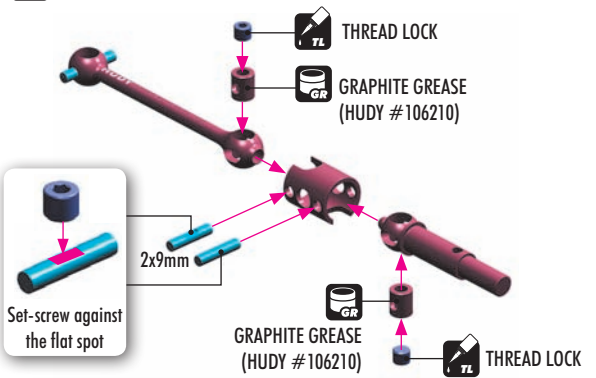

ECS DRIVE SHAFTS

ECS drive shafts are available in 51mm length in kit, or optional 50mm & 52mm lengths. The ECS drive shafts were developed to decrease front wheel vibration when racing with a solid front axle, thus providing a much smoother and quieter ride and increased steering.

Longer drive shafts (52mm) make the car easier to drive because they give more traction and better stability, mainly in chicanes. However, the car will understeer more than with shorter (50mm) shafts which give a lot of steering and make the car more aggressive. Both left & right shafts should ALWAYS be the same length at one end of the car (front or rear).

52mm shafts are recommended for **carpet high-traction tracks**.
51mm shafts are recommended for **carpet tracks and large asphalt tracks**.
50mm shafts are recommended for **low-traction or tight asphalt tracks**.

The new 51mm drive shafts which are included in the kit are the best compromise between 50 and 52mm length.

OPTION #305242
DRIVE SHAFT REPLACEMENT CAP
3.5MM ORANGE - STRONG (4)



DRIVE SHAFTS

#305323	50MM - STEEL
#305324	52MM - STEEL
#305326	52MM - ALU
#305328	50MM - ALU
#305332	52MM - ECS
#305333	50MM - ECS
#305334	51MM - ECS

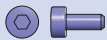

902205
SH M2x5

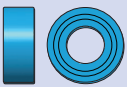

940510
BB 5x10x4



980210
P 2x10

L=R REAR TRANSMISSION

ALTERNATIVE STANDARD REAR SUSPENSION INITIAL SETTING

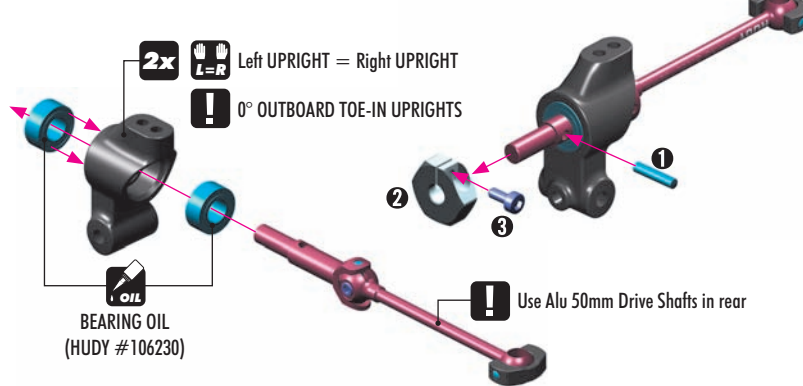

ALTERNATIVE ACTIVE REAR SUSPENSION™

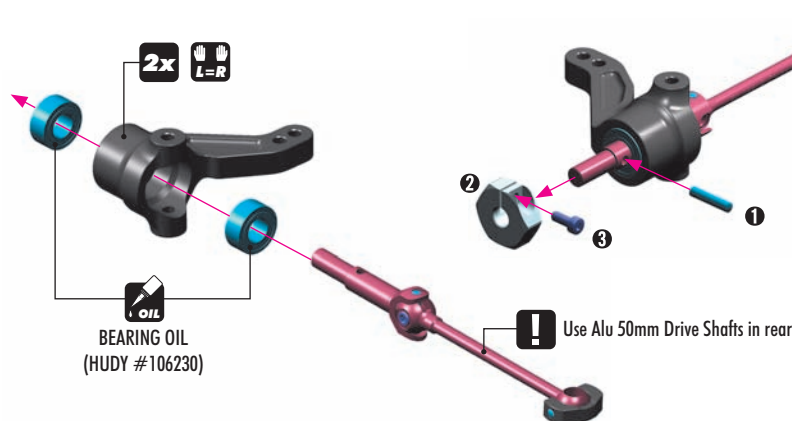

T4 OPTIONAL PARTS

UPRIGHTS	
#303351	1° - R MEDIUM (2-HOLE)
#303352	0° - R/L MEDIUM (2-HOLE)
#303353	1° - R HARD (2-HOLE)
INCLUDED	#303354 0° - R/L HARD (2-HOLE)
#303360	0° - R/L GRAPHITE (2-HOLE)
#303361	1° - L MEDIUM (2-HOLE)
#303362	0° - R/L MEDIUM (1-HOLE)
#303363	1° - L HARD (2-HOLE)
#303364	0° - R/L HARD (1-HOLE)
#303358	ALU 1° - R/L (4-HOLE)
#303359	ALU 2° - R/L (4-HOLE)

WHEEL HUBS	
INCLUDED	#305350-K ALU - OFFSET (0 mm)
#305351	ALU - OFFSET (-0.75 mm)
#305352	ALU - OFFSET (+0.75 mm)
#305353	ALU - OFFSET (+1.5 mm)

STEERING BLOCKS	
INCLUDED	#302252 MEDIUM
#302253	HARD
#302254	GRAPHITE
#302256	ALU



REAR TOE-IN
TRACK-WIDTH

5. FRONT & REAR TRANSMISSION



902205
SH M2x5



940510
BB 5x10x4



980210
P 2x10



REAR TOE-IN
TRACK-WIDTH

2x FRONT TRANSMISSION

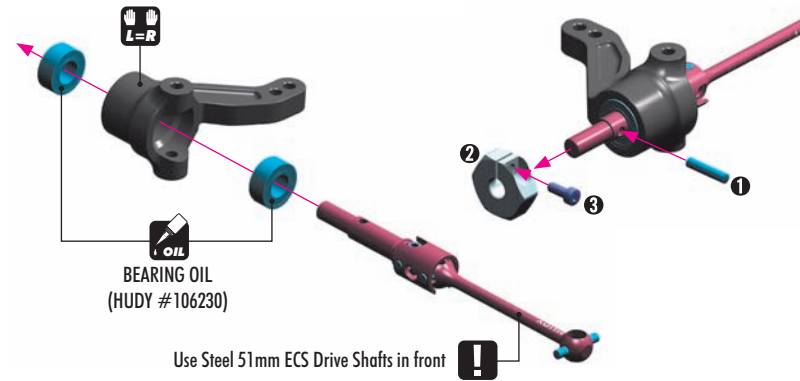

T4 OPTIONAL PARTS

WHEEL HUBS		
INCLUDED	#305350-K	ALU - OFFSET 0 MM
	#305351	ALU - OFFSET -0.75 MM
	#305352	ALU - OFFSET +0.75 MM
	#305353	ALU - OFFSET +1.5 MM

STEERING BLOCKS		
	#302252	MEDIUM
INCLUDED	#302253	HARD
	#302254	GRAPHITE
	#302256	ALU

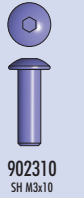

902310
SH M3x10



CASTER ADJUSTMENT

2x FRONT TRANSMISSION

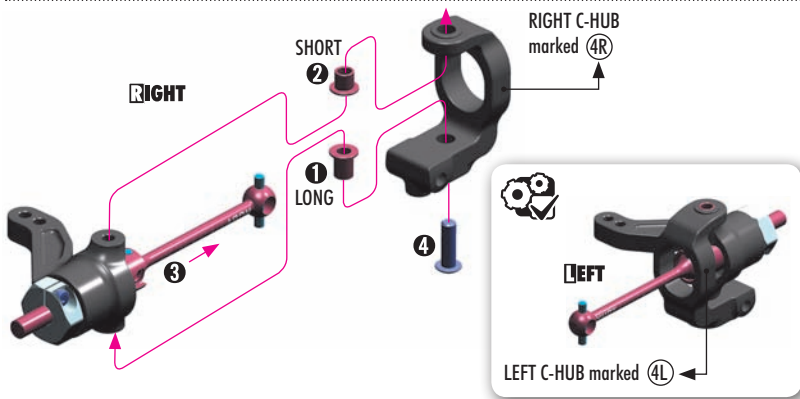

2x ACTIVE REAR SUSPENSION™

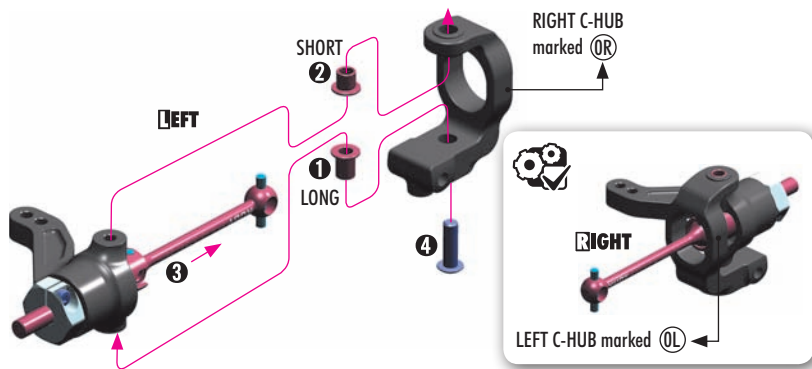

C-HUBS FRONT TRANSMISSION		
	#302334	ALU 0° - R + L
	#302335	ALU 2° - RIGHT
	#302336	ALU 2° - LEFT
	#302337	ALU 4° - RIGHT
	#302338	ALU 4° - LEFT
	#302339	ALU 6° - RIGHT
	#302340	ALU 6° - LEFT
	#302361	2° - RIGHT - MEDIUM
	#302362	2° - LEFT - MEDIUM
INCLUDED	#302363	4° - RIGHT - MEDIUM
INCLUDED	#302364	4° - LEFT - MEDIUM
	#302365	6° - RIGHT - MEDIUM
	#302366	6° - LEFT - MEDIUM
	#302371	2° - RIGHT - HARD
	#302372	2° - LEFT - HARD
	#302373	4° - RIGHT - HARD
	#302374	4° - LEFT - HARD
	#302375	6° - RIGHT - HARD
	#302376	6° - LEFT - HARD
	#302383	4° - RIGHT - GRAPHITE
	#302384	4° - LEFT - GRAPHITE

C-HUBS ACTIVE REAR TRANSMISSION		
	#302334	ALU 0°
	#302359	0° - RIGHT - MEDIUM
	#302360	0° - LEFT - MEDIUM
INCLUDED	#302369	0° - RIGHT - HARD
INCLUDED	#302370	0° - LEFT - HARD
	#302379	0° - RIGHT - GRAPHITE
	#302380	0° - LEFT - GRAPHITE

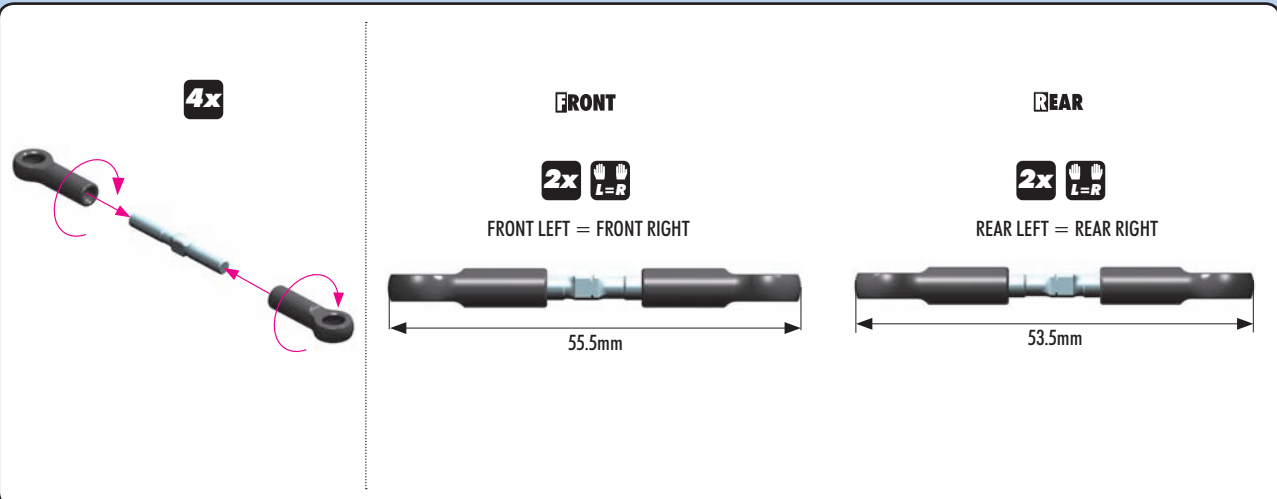

CAMBER ADJUSTMENT

5. FRONT & REAR TRANSMISSION



303122-K
SHIM 3x6x1



303127-K
SHIM 3x6x4



901304
SB M3x4

REAR TRANSMISSION

ALTERNATIVE STANDARD REAR SUSPENSION INITIAL SETTING

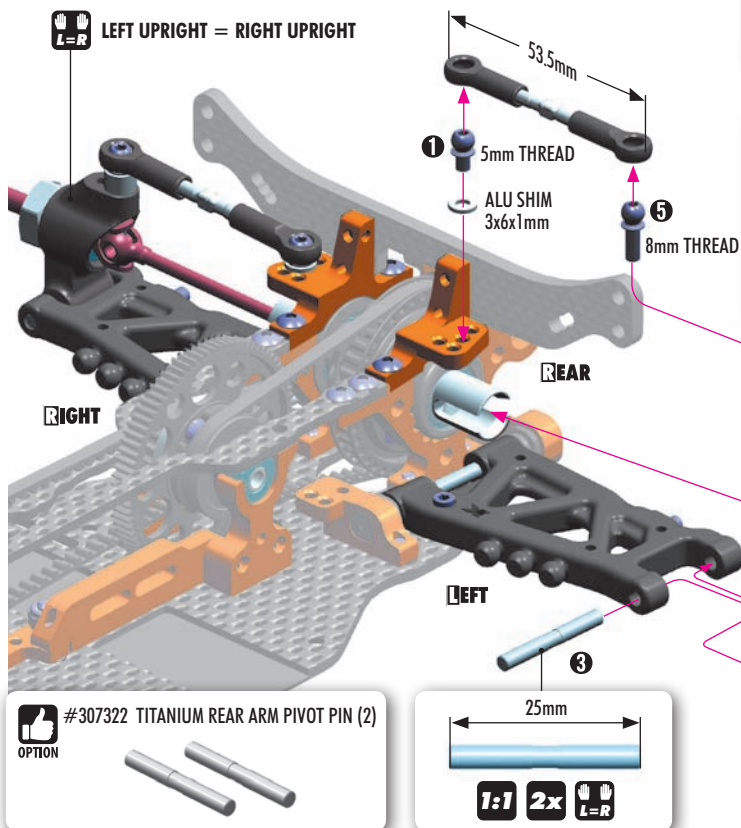

INITIAL SETTING

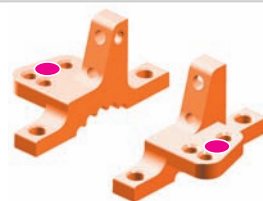

1-HOLE REAR UPRIGHTS (See page 19)

An optional 1-hole rear upright is available for fine tuning. This optional upright may be used on high-traction tracks or tracks with long sweepers, since the position of the center hole will allow faster driving through those corners because of better cornering speed.



303122-K
SHIM 3x6x1



303129
SHIM 3x6x1



901304
SB M3x4

ALTERNATIVE ACTIVE REAR SUSPENSION™

STEP 1

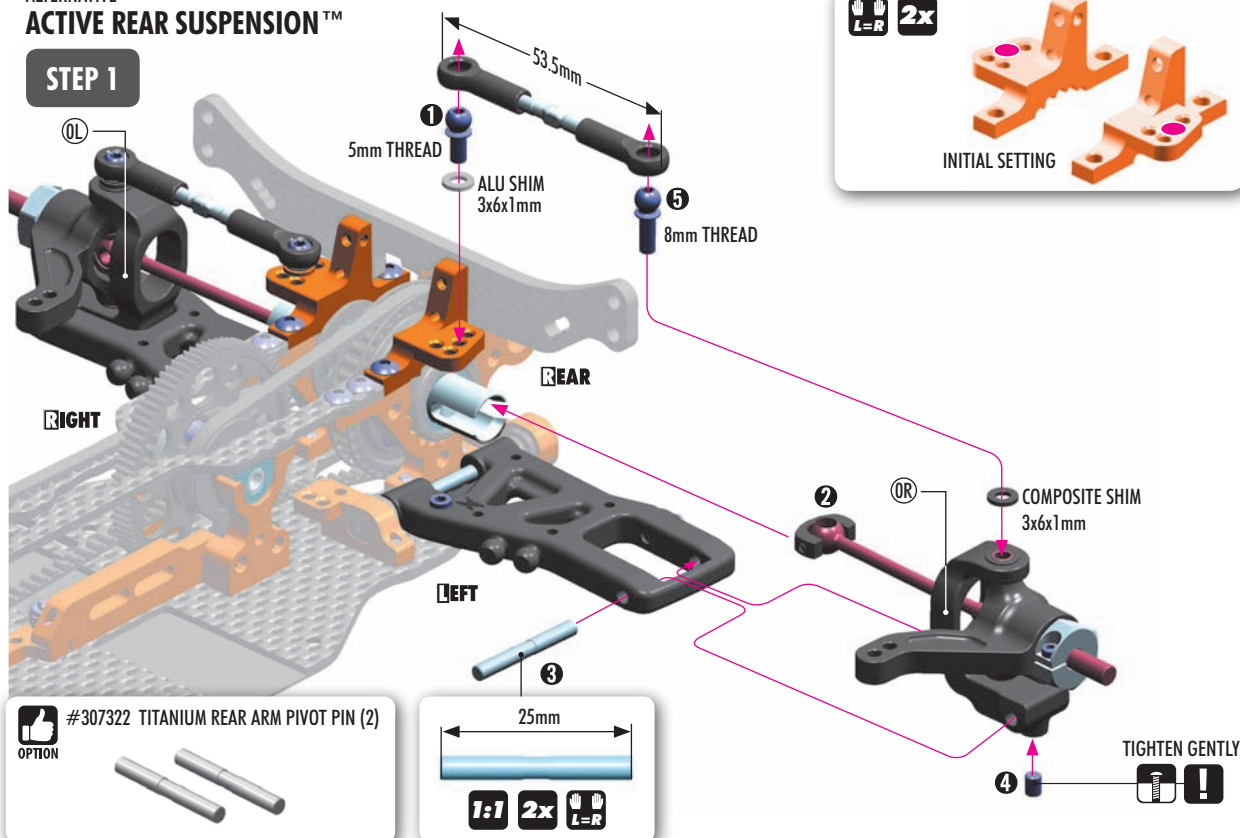

INITIAL SETTING

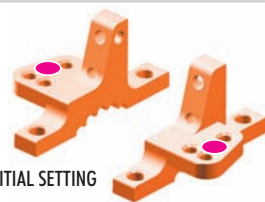

ROLL CENTER
CAMBER

5. FRONT & REAR TRANSMISSION

10

303129
SHIM 3x6x1



903306
SFH M3x6

2x L=R REAR TRANSMISSION

ALTERNATIVE ACTIVE REAR SUSPENSION™

STEP 2

INITIAL SETTING



IMPORTANT

ALWAYS USE ONLY THIS POSITION

ARS LINKAGE



The angle of the ARS linkage – which is made by adding/removing shims on the steering block and ARS post mount – changes the toe-in characteristics of the rear tires under rolling effect; when the car is pressed the toe-in can either increase or decrease.

Check the toe-in change on your set-up system when the car is in neutral position and when is pressed down. For more information see the HUDY Set-up Book.

5mm THREAD
COMPOSITE SHIM 3x6x1mm
Do not use for basic set-up

57mm

6mm THREAD

COMPOSITE SHIM 3x6x1mm
Do not use for basic set-up

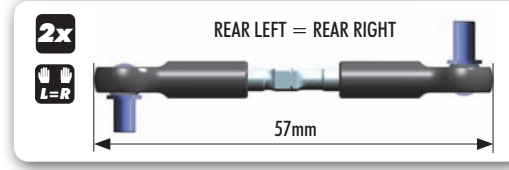
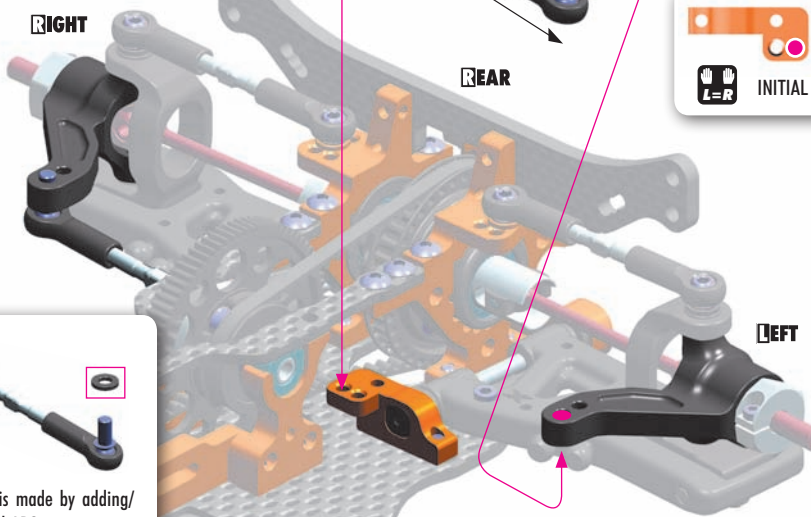

ACTIVE TOE-IN

303123-K
SHIM 3x6x2



901304
SB M3x4

2x L=R FRONT TRANSMISSION

55.5mm

5mm THREAD

ALU SHIM 3x6x2mm

10mm THREAD

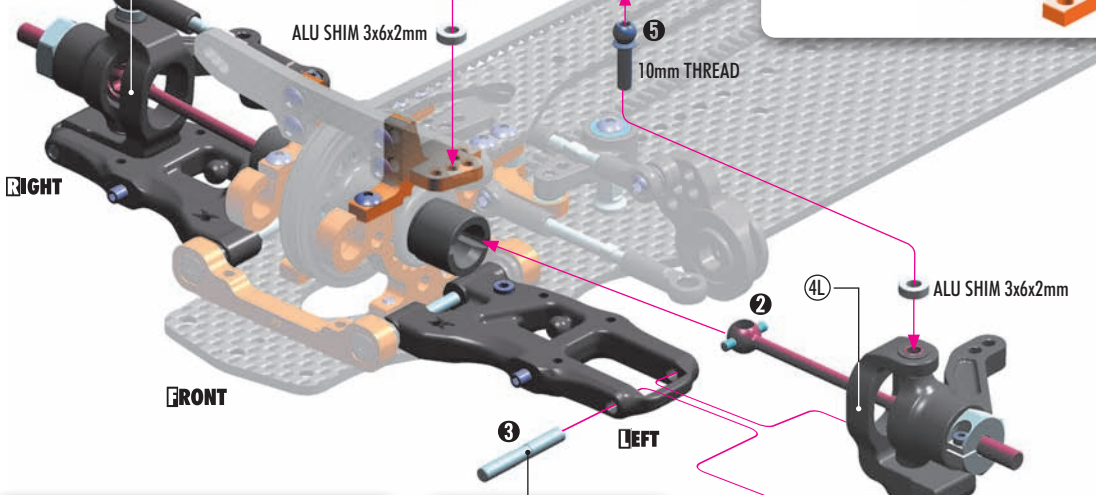
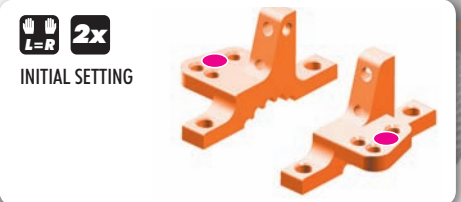

#307222 TITANIUM FRONT ARM PIVOT PIN (2)

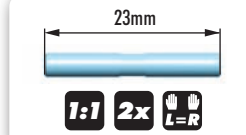

TIGHTEN GENTLY



ROLL-CENTER

5. FRONT & REAR TRANSMISSION

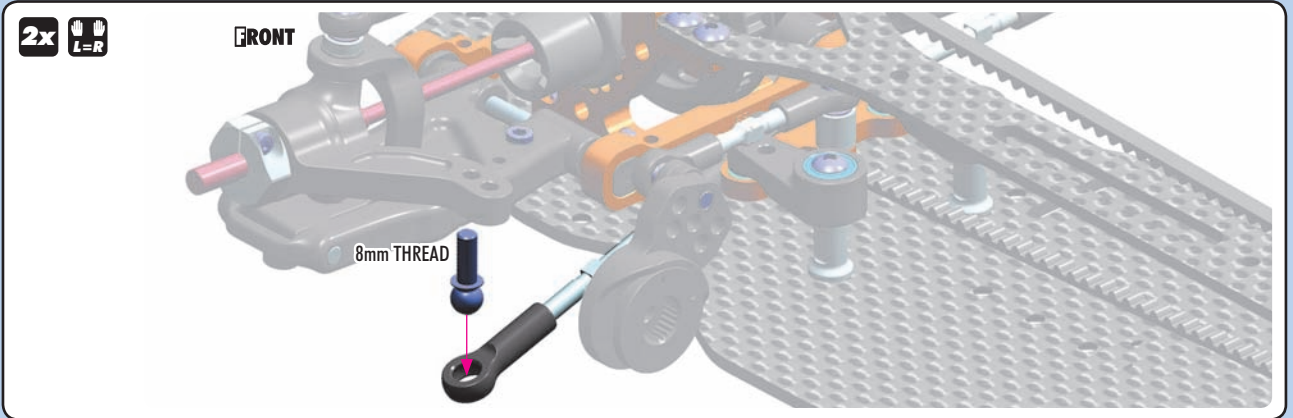

10
303129
SHIM 3x6x1

L-R FRONT TRANSMISSION

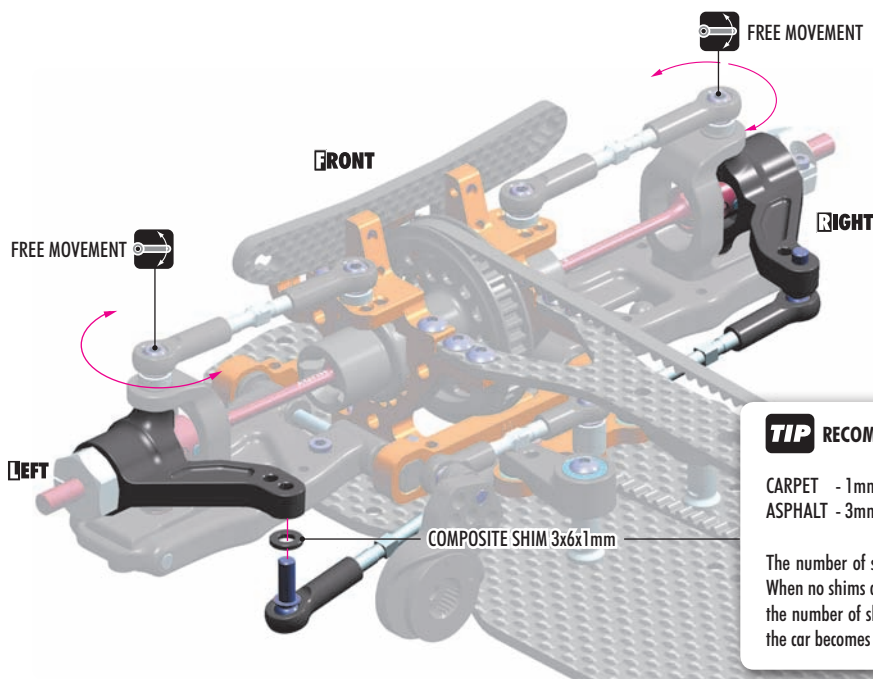

TIP RECOMMENDED BUMPSTEER SETTINGS:

CARPET - 1mm thick shim
ASPHALT - 3mm thick shims

The number of shims changes the angles of the steering linkage. When no shims are used, the car is easy to drive into the corner. As the number of shims is increased, in-corner steering increases but the car becomes more difficult to drive.



10
930407
BB 4x7x2.5



REAR ANTI-ROLL BARS	
OPTION	#303801 REAR 1.1 MM
	#303802 REAR 1.2 MM
INCLUDED	#303803 REAR 1.3 MM
	#303804 REAR 1.4 MM
	#303805 REAR 1.5 MM
	#303806 REAR 1.6 MM

FRONT ANTI-ROLL BARS	
OPTION	#302802 FRONT 1.2 MM
	#302803 FRONT 1.3 MM
INCLUDED	#302804 FRONT 1.4 MM
	#302805 FRONT 1.5 MM
	#302806 FRONT 1.6 MM

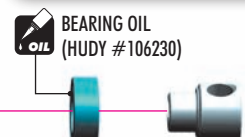

5. FRONT & REAR TRANSMISSION

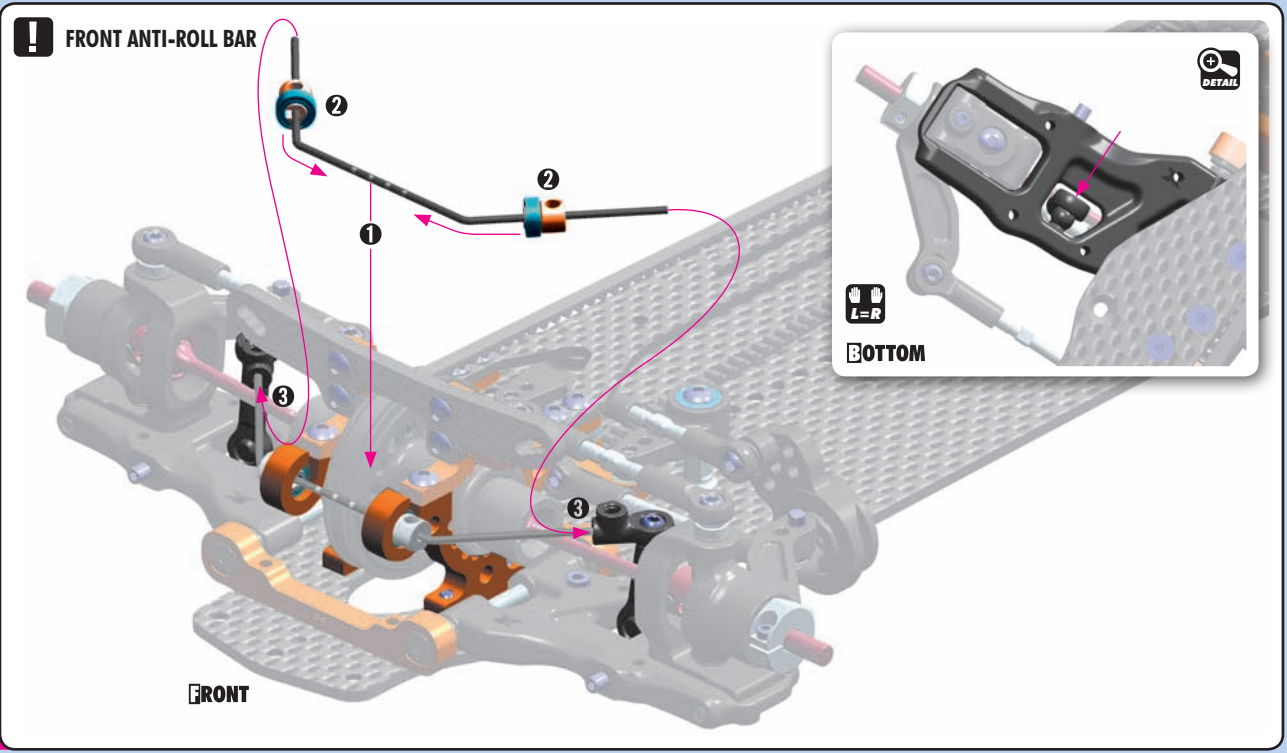

- 901303 SB M3x3
- 901304 SB M3x4

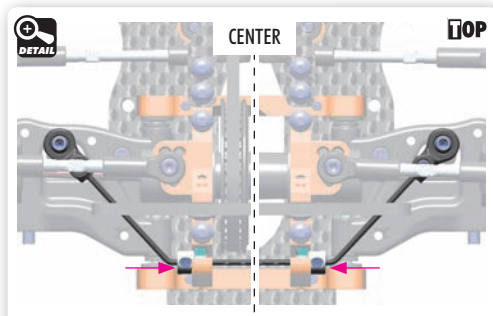
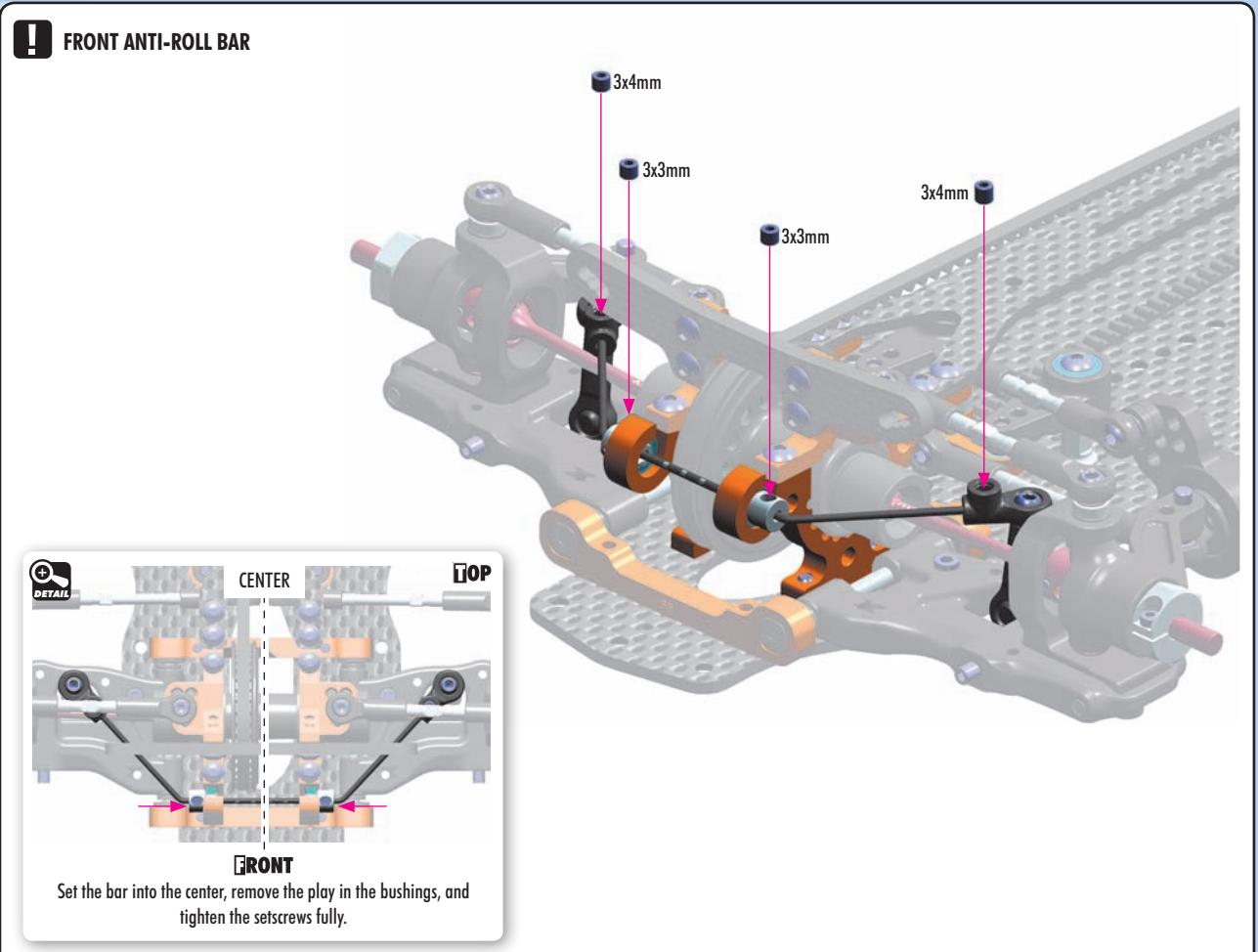

Set the bar into the center, remove the play in the bushings, and tighten the setscrews fully.

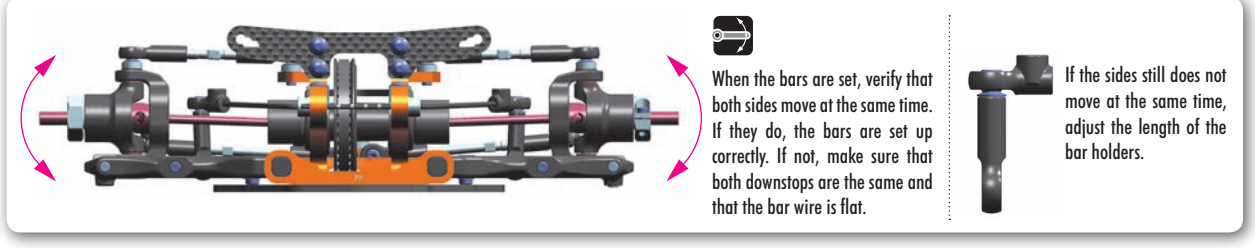

5. FRONT & REAR TRANSMISSION

REAR ANTI-ROLL BAR

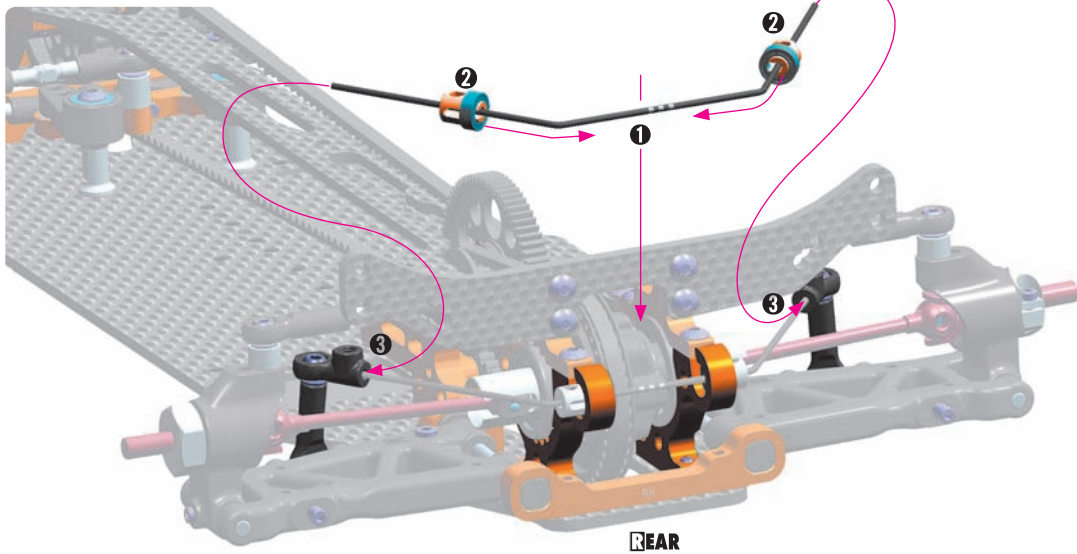

REAR

2x INITIAL POSITION

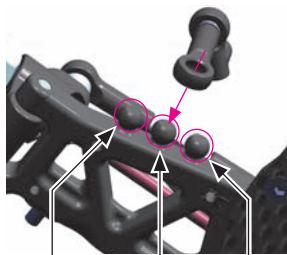

OUTER MIDDLE INNER

STANDARD SUSPENSION INITIAL SETTING = MIDDLE BALL

Use the **INNER** ball on low-traction tracks (mainly low-traction carpet tracks). The car will have more traction & more steering, but will be more difficult to drive because the car will roll more.

Use the **MIDDLE** ball on low- to medium-traction tracks (asphalt, carpet). The car will have a little less rear traction and the car will roll a little less which will make it easier to drive with more cornering speed.

Use the **OUTER** ball on high-traction tracks (mainly high-traction asphalt tracks). The car will roll even less which will allow the use of more throttle in the corners, however the car will have less traction.

ACTIVE REAR SUSPENSION™

ARS arm has only two balls which are identical as inner & middle balls on the standard rear arm.

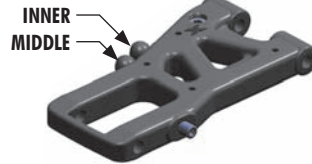

ANTI-ROLL BARS



901303
SB M3x3



901304
SB M3x4

REAR ANTI-ROLL BAR

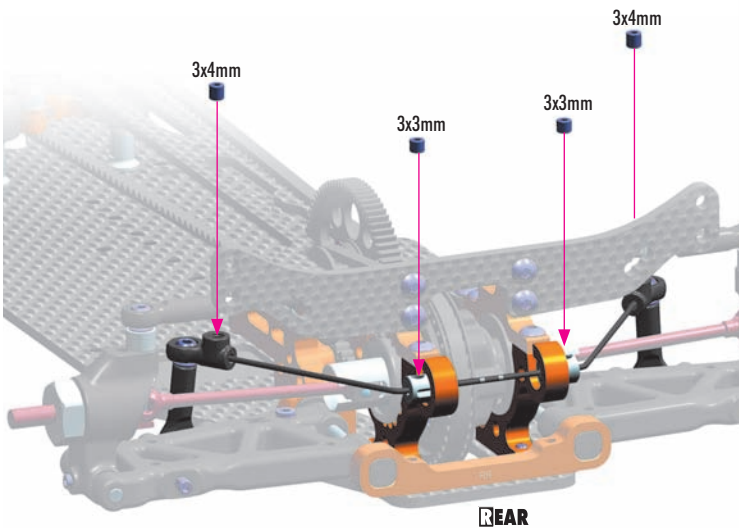

REAR

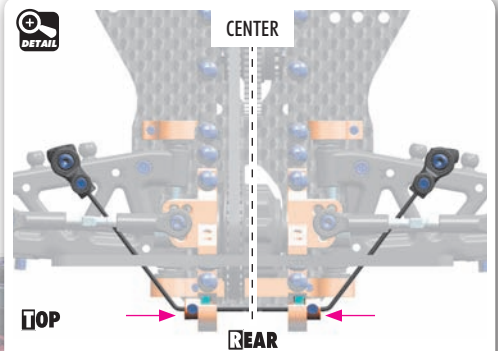

Set the bar into the center, remove the play in the bushings, and tighten the setscrews fully.

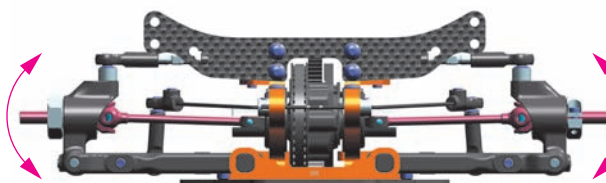

When the bars are set, verify that both sides move at the same time. If they do, the bars are set up correctly. If not, make sure that both downstops are the same and that the bar wire is flat.



If the sides still do not move at the same time, adjust the length of the bar holders.

6. SHOCK ABSORBERS

4x

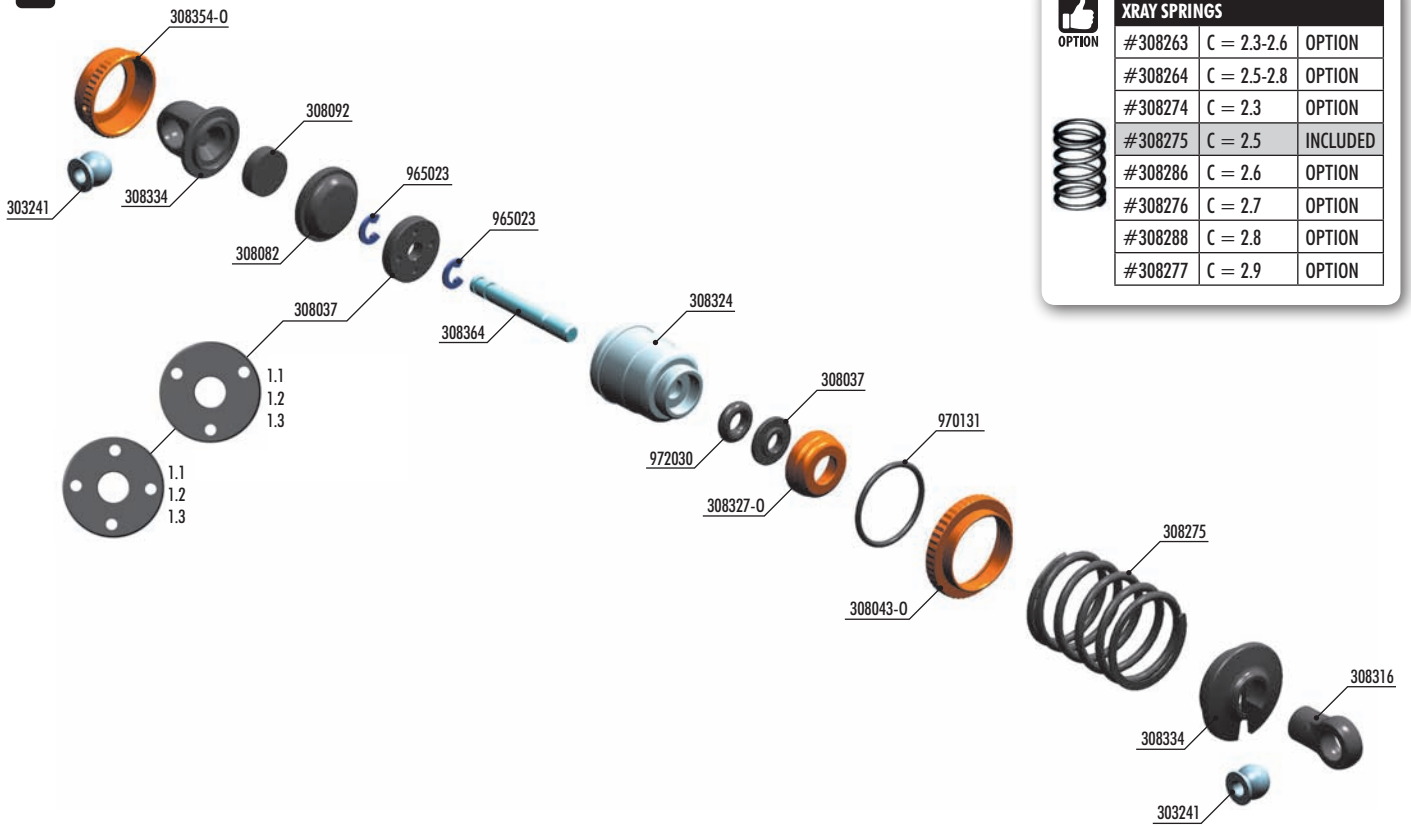

OPTION

XRAY SPRINGS

#308263	C = 2.3-2.6	OPTION
#308264	C = 2.5-2.8	OPTION
#308274	C = 2.3	OPTION
#308275	C = 2.5	INCLUDED
#308286	C = 2.6	OPTION
#308276	C = 2.7	OPTION
#308288	C = 2.8	OPTION
#308277	C = 2.9	OPTION



#308029

OPTION

ULP ALU PROGRESSIVE SHOCK SYSTEM - SET (2)

Progressive shock system for touring cars for improved traction and steering characteristics. Shock insert with 3 triangular cutouts used with piston WITHOUT holes. The hardness of the shock is influenced not by the holes in the piston, but rather by the insert.



#308031-0

OPTION

ALU XRAY SHOCK SPRING RETAINING COLLAR - ORANGE (4)



BAG

06

- 30 3241 BALL UNIVERSAL 5.8 MM HEX (4)
- 30 8037 COMPOSITE PISTONS 4-HOLE 1.0-1.2MM, 3-HOLE 1.0-1.2MM
- 30 8043-0 ULP ALU SHOCK ADJUSTABLE NUT - ORANGE (2)
- 30 8082 T4 SHOCK ABSORBER MEMBRANE (4)
- 30 8092 T4 SHOCK FOAM INSERTS (4)
- 30 8308-0 ULP ALU SHOCK ABSORBER-SET - ORANGE (2)
- 30 8316 SHOCK BALL JOINT - OPEN (4)
- 30 8324 ULP ALU SHOCK BODY (2)
- 30 8327-0 ALU CAP FOR XRAY SHOCK BODY - ORANGE

- 30 8334 ULP COMPOSITE SHOCK PARTS
- 30 8354-0 ULP ALU SHOCK CAP-NUT WITH VENT HOLE - ORANGE (2)
- 30 8364 T4 HARDENED SHOCK SHAFT FOR ALU SHOCKS (2)
- 30 8275 XRAY SPRING-SET C=2.5
- 96 5023 E-CLIP 2.3 (10)
- 97 0131 O-RING 13 x 1.0 (10)
- 97 2030 SILICONE O-RING 3 x 2 (10)



965023
C 2.3

4x

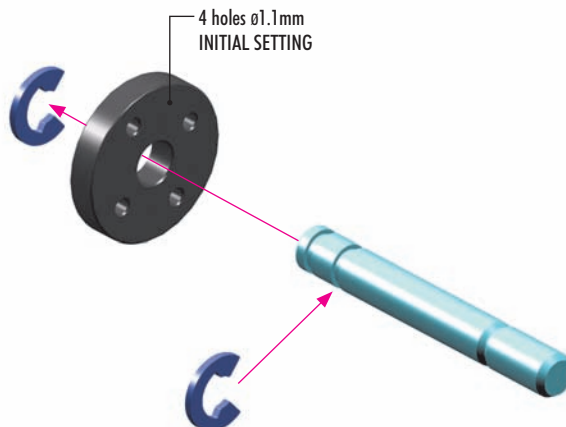

6. SHOCK ABSORBERS

972030
0 3x2

4x

970131
0 13x1.0

4x

4x

TIP #183011
HUDY RC SHOCK-PLIER UNI TOOL

INCORRECT ✗ **CORRECT** ✓

INITIAL SETTING 1mm

! **HINT:** Pre-thread the ball joint using an M3 screw.
WARNING! Be careful not to pre-thread too far, since the ball joint may split or the plastic threads may strip out.

4x

OIL 400cSt **SHOCK FILLING**

- Fully extend the piston rod so the piston is at the bottom of the shock body.
- Hold the shock upright and slightly overfill the shock body with shock oil.
- Let the oil settle and allow air bubbles to rise to the top. Slowly move the piston up and down to allow oil into all cavities within the shock body.
- Extend the piston rod most of the way out of the shock body. Let the shock rest for 5 minutes to allow the air bubbles to escape.
- Add shock oil as necessary.

OPTION	HUDY SHOCK OILS (50ml)		
	#106310	100cSt	#106355 550cSt
	#106315	150cSt	#106360 600cSt
	#106320	200cSt	#106365 650cSt
	#106325	250cSt	#106370 700cSt
	#106330	300cSt	#106375 750cSt
	#106335	350cSt	#106380 800cSt
INCLUDED	#106340	400cSt	#106390 900cSt
	#106345	450cSt	#106410 1000cSt
	#106350	500cSt	#106420 2000cSt

4x

CUTAWAY VIEW

After you insert the membrane, ensure that it is fully seated inside the alu cap.

6. SHOCK ABSORBERS



- 1 When installing the shock cap assembly on the shock body, some oil will leak out... this is normal.
- 2 Tighten the cap and clean off any excess oil.
- 3 After the shock is assembled, the shock rod will push itself out of the shock body fairly quickly.
- 4 Follow the next procedure to adjust the rebound.

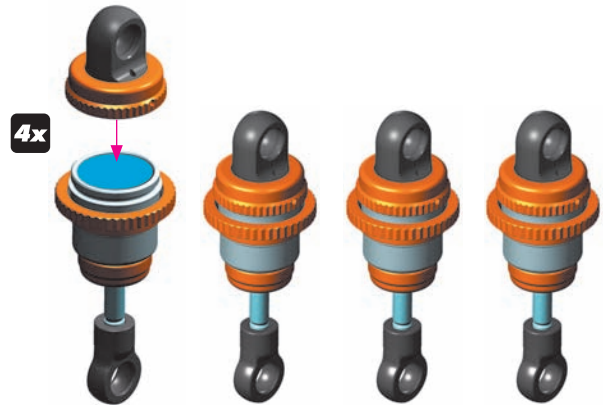

4x

REBOUND ADJUSTMENT

RELEASE 2-3 turns

1

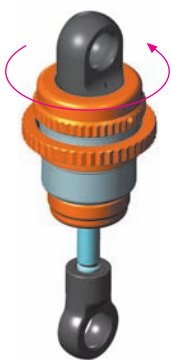

2



TIGHTEN FULLY

3

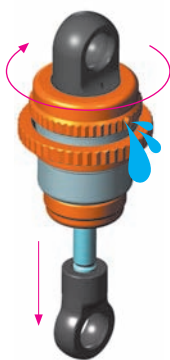

AFTER THE SHOCK IS ASSEMBLED YOU HAVE TO SET THE SHOCK REBOUND:

- 1 Release the shock cap by 2-3 turns.
- 2 Push the shock shaft fully up. For the first time the extra oil will release through the hole in the alu cap-nut.
- 3 Tighten the shock cap. When tightening the shock cap, extra oil will again release through the hole in the alu cap - nut. When tightening, the shock shaft will push out from the shock body.

4x

REBOUND CHECK

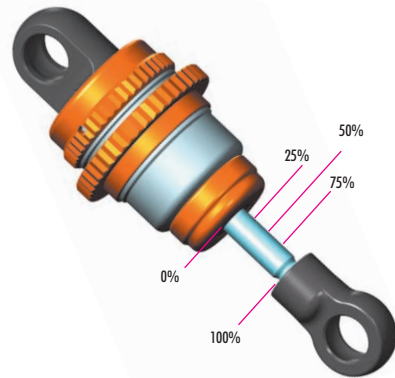

REBOUND CHECK:

It is very important to push the shock shaft into the shock body slowly otherwise air can come into the shock body which would create bubbles.

- 100% rebound - do not do step 1 and 3
- 75% rebound - repeat step 1 and 3 until the shock shaft will push out 75% of its length
- 50% rebound - repeat step 1 and 3 until the shock shaft will push out 50% of its length
- 25% rebound - repeat step 1 and 3 until the shock shaft will push out 25% of its length
- 0% rebound - repeat step 1 and 3 until the shock shaft will push out 0% of its length

If the shock shaft does not rebound enough, you will have to refill the shock with shock oil, and then repeat the bleeding and rebound adjustment procedure.

4x SHOCK LENGTH ADJUSTMENT:

! It is VERY IMPORTANT that all shocks are equal length.

Fully extend the shock absorber and measure the end-to-end length; we recommend using digital calipers to give an accurate measurement. If a shock absorber is shorter or longer than others, adjust the shock length by tightening or loosening the ball joint on the shock rod.

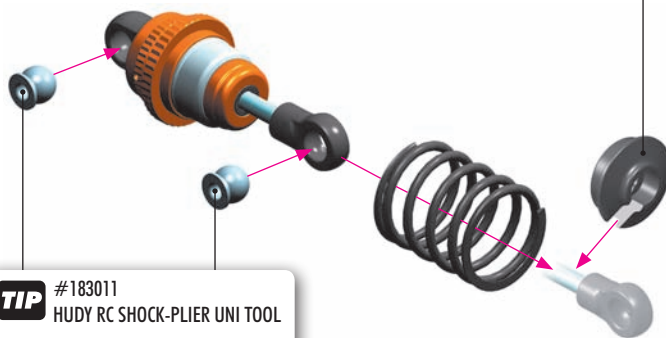

TIP #183011 HUDY RC SHOCK-PLIER UNI TOOL



! #308031-0 ALU XRAY SHOCK SPRING RETAINING COLLAR - ORANGE (4)
OPTION



ASSEMBLY VIEW



7. FRONT & REAR ASSEMBLY

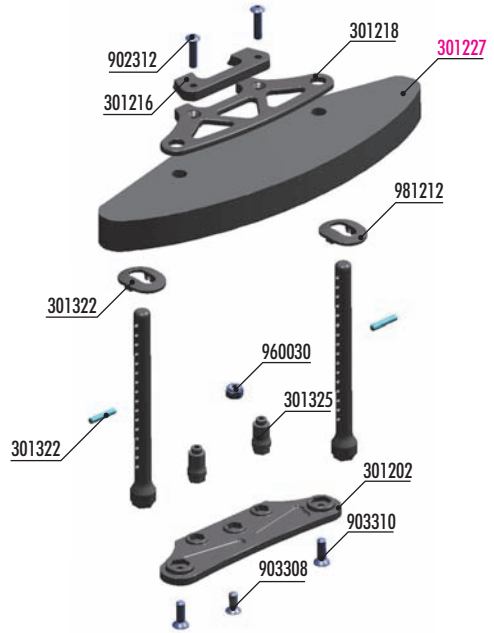
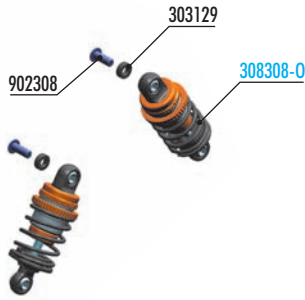
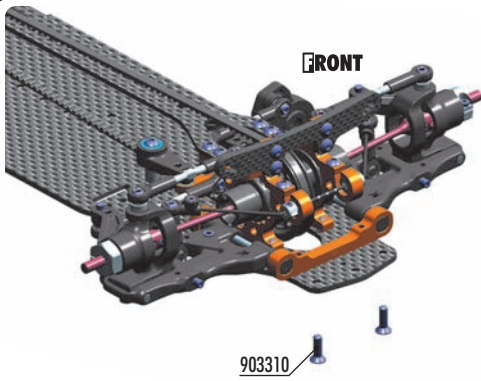

FRONT BODY MOUNT SET			
#301322	0mm	INCLUDED	
#301323	+1mm	OPTION	
#301324	+2mm	OPTION	

#301203
OPTION **IMPACT-ABSORBING BUMPER**

#301228
OPTION **T4 FOAM BUMPER WIDE - HARD**

#301213
OPTION **GRAPHITE UPPER HOLDER FOR BUMPER 2.5MM**

#301351-0
OPTION **ALU ADJUSTABLE BODY POST STOP (2)**

BAG
07

- 30 1202 COMPOSITE BUMPER
- 30 1216 COMPOSITE BUMPER UPPER HOLDER BRACE
- 30 1218 COMPOSITE UPPER HOLDER FOR BUMPER
- 30 1322 FRONT BODY MOUNT SET
- 30 1325 T4 COMPOSITE BRACE FOR BUMPER - LOW (2)
- 30 3129 COMPOSITE SET OF WHEELBASE SHIMS (3x1MM; 1x2MM) (2)
- 90 2308 HEX SCREW SH M3x8 (10)
- 90 2312 HEX SCREW SH M3x12 (10)
- 90 3308 HEX SCREW SFH M3x8 (10)
- 90 3310 HEX SCREW SFH M3x10 (10)
- 96 0030 NUT M3 (10)
- 98 1212 PIN 2x12 (10)
- 30 1227 **T4 FOAM BUMER - LIGHT & STRONG**
- 30 8308-0 **ULP ALU SHOCK ABSORBER-SET - ORANGE (2)**

- 903308 SFH M3x8
- 903310 SFH M3x10
- 960030 N M3

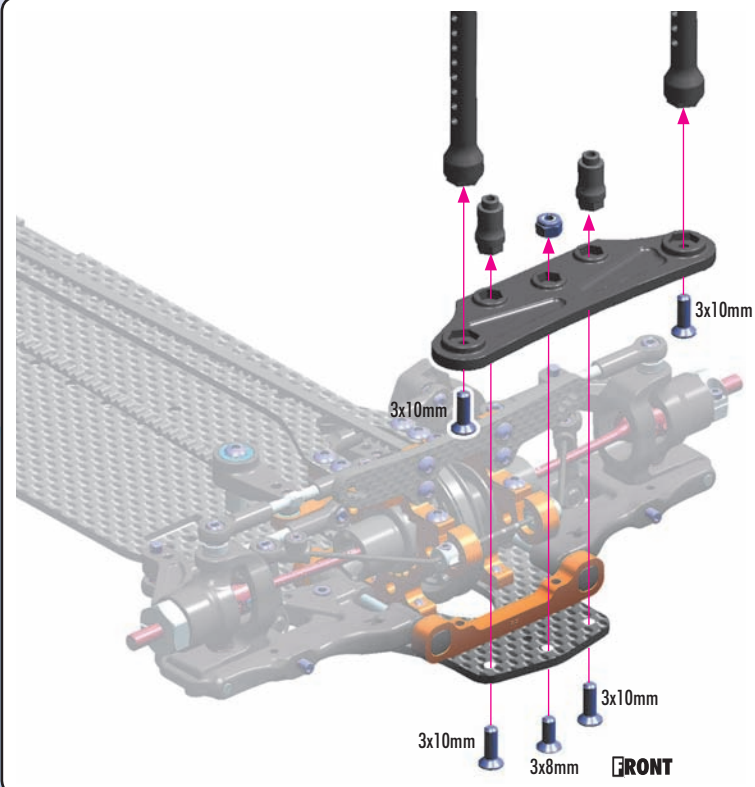

#301203
OPTION **IMPACT-ABSORBING BUMPER**

7. FRONT & REAR ASSEMBLY



902312
SH M3x12

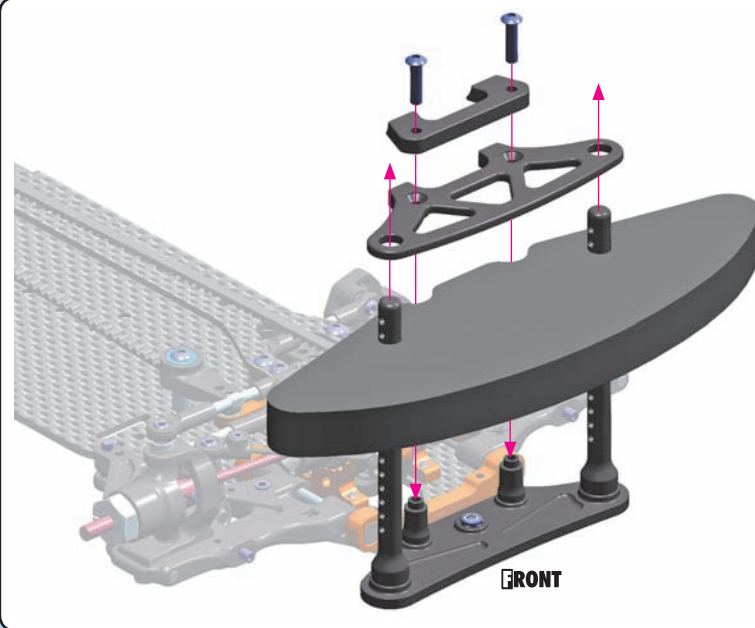

#301213
GRAPHITE UPPER HOLDER FOR BUMPER 2.5MM



#301228
T4 FOAM BUMPER WIDE - HARD

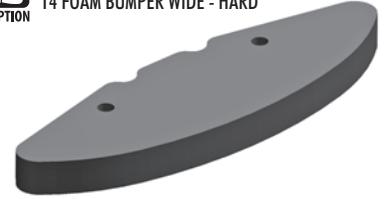

2x
L=R



981212
P 2x12

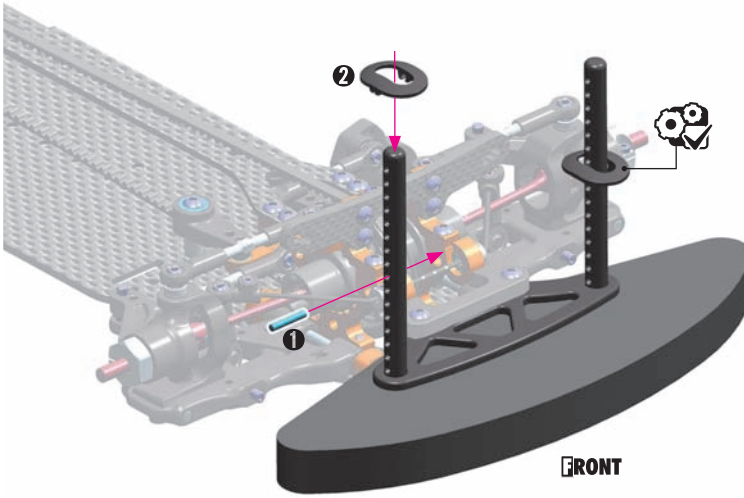

#301351-0
ALU ADJUSTABLE BODY POST STOP (2)



Very handy, easily externally adjustable body post from Swiss 7075 T6 aluminum. Allows for adjustment of body height by 3mm without needing to change the position on the body post.



FRONT BODY MOUNT SET

#301322	0mm	INCLUDED
#301323	+1mm	OPTION
#301324	+2mm	OPTION

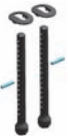

L=R



902308
SH M3x8



303129
SHIM 3x6x2

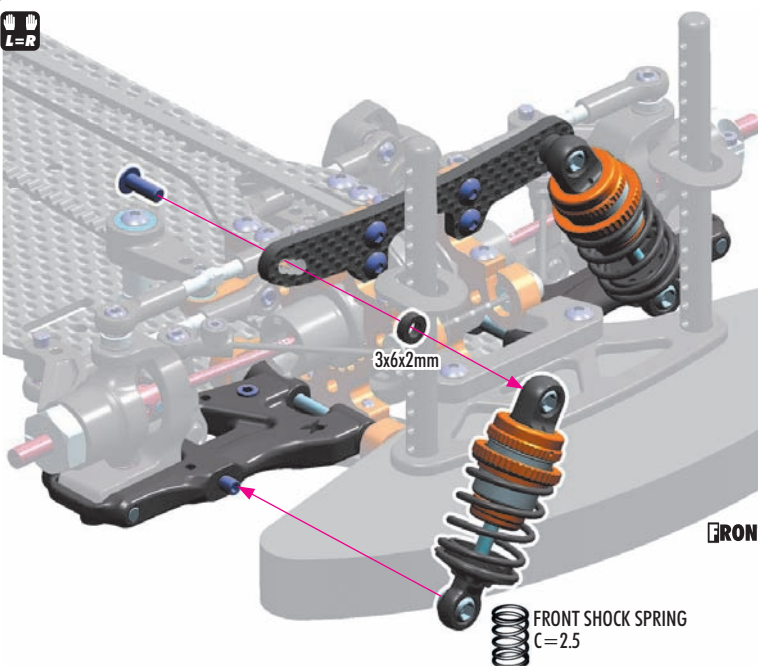

INITIAL SETTING



#302085
T4 SHOCK TOWER FRONT 3.0MM GRAPHITE

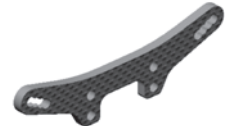

#308307-0
XRAY T4 ALU SHOCK ABSORBER-SET - ORANGE (2)



For some very specific racing conditions like extremely low traction, the shocks with shock towers from previous T4 cars will fit onto T4'18 and are available as an option.



SHOCK POSITION
RIDE HEIGHT
DROOP

7. FRONT & REAR ASSEMBLY

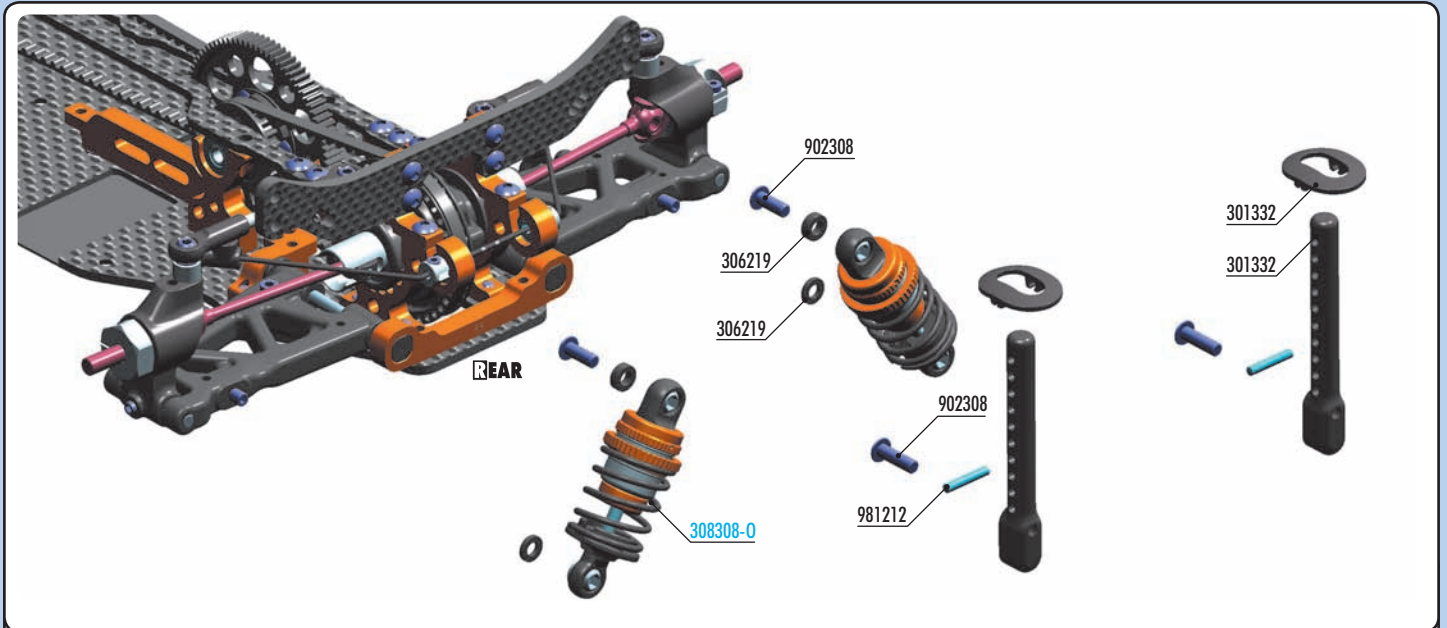

30 1332 REAR BODY MOUNT SET
30 6219 COMPOSITE SET OF SERVO SHIMS (4)

90 2308 HEX SCREW SH M3x8 (10)
98 1212 PIN 2x12 (10)
30 8308-0 ULP ALU SHOCK ABSORBER-SET - ORANGE (2)

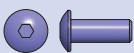

902308
SH M3x8

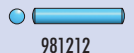

981212
P 2x12

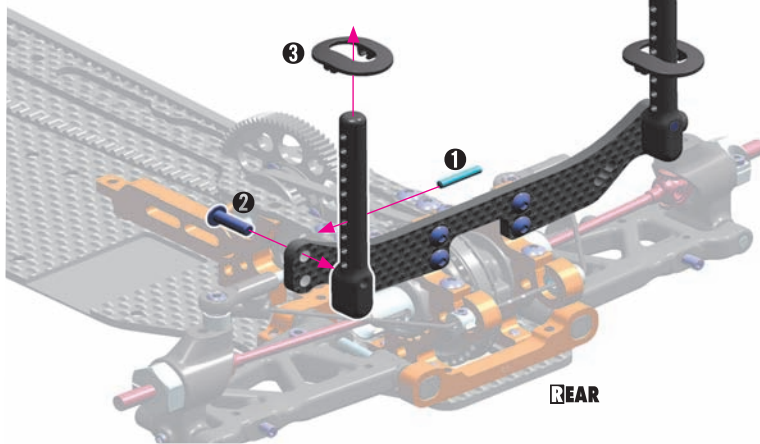

#301351-0
ALU ADJUSTABLE BODY POST STOP (2)



Very handy, easily externally adjustable body post from Swiss 7075 T6 aluminum. Allows for adjustment of body height by 3mm without needing to change the position on the body post.



REAR BODY MOUNT SET

#	Offset	Status
#301332	0mm	INCLUDED
#301333	+1mm	OPTION
#301334	+2mm	OPTION

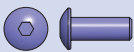

902308
SH M3x8

306219
SHIM 3x6x2

306219
SHIM 3x6x3

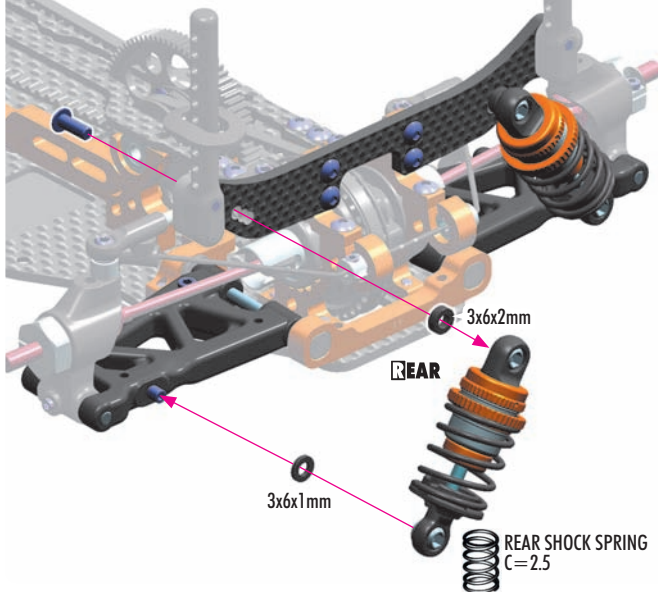

#303086
T4 SHOCK TOWER REAR 3.0MM GRAPHITE



#308307-0
XRAY T4 ALU SHOCK ABSORBER-SET - ORANGE (2)



For some very specific racing conditions like extremely low traction, the shocks with shock towers from previous T4 cars will fit onto T4'18 and are available as an option.



SHOCK POSITION
RIDE HEIGHT
DROOP



903306
SFH M3x6

ALTERNATIVE 1

STANDARD STEERING ARM MOUNTING (INITIAL SETTING)

Standard steering mounting system provides maximum steering response and makes the car more precise.

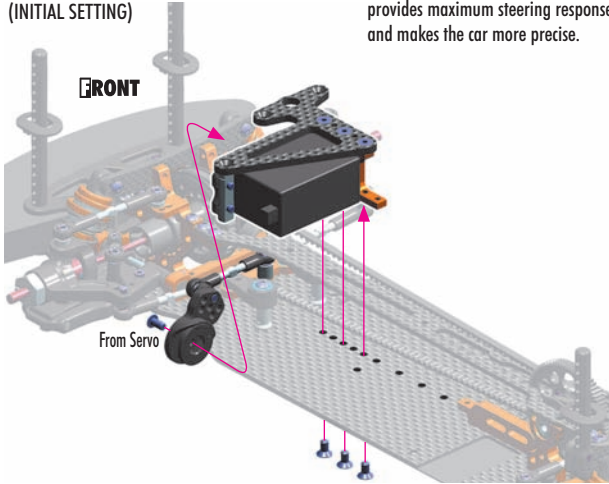

For improved weight balance and for more space for electronics, we recommend using a narrow, light servo.



IMPORTANT!



When adjusting steering on the radio, we recommend using full steering adjustment in order to get the best steering from the car. It is important to verify that the steering block does not touch the C-hub; that would lead to chassis tweak due to extra servo strain.

ALTERNATIVE 2

FLOATING STEERING ARM MOUNTING

Floating steering mounting system makes the car easier to drive over curbs and on bumpy tracks. Helps prevent oversteer.

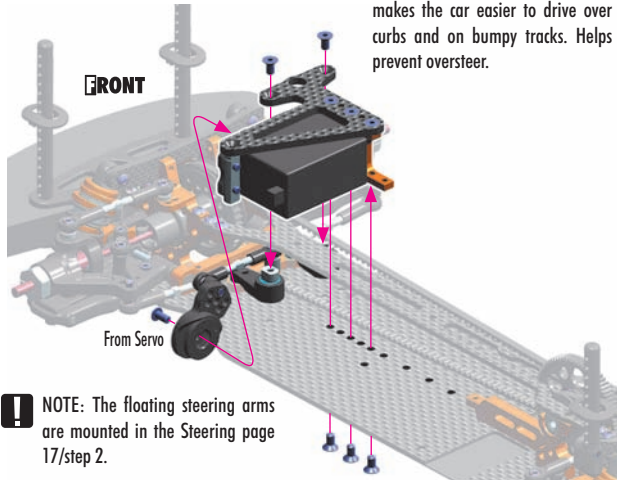

NOTE: The floating steering arms are mounted in the Steering page 17/step 2.

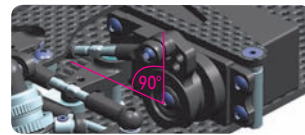

Attach servo arm to servo output shaft using screw from servo. Servo saver must be perpendicular to chassis when servo is in neutral.



INLINE FLEX CHASSIS ADJUSTMENT

The inline chassis flex adjustment has a direct effect on the steering characteristics of the car. The more stiff the inline chassis flex is, better steering response and more in-corner steering is generated.

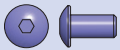

902306
SH M3x6

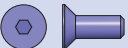

903308
SFH M3x8



960030
N M3



303123-0
SHIM 3x6x2



306219
SHIM 3x6x2

1

INITIAL SETTING

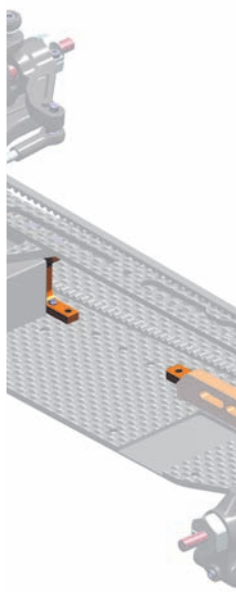

2

Attach the graphite reinforcement plate from the top so the chassis stays independent from inline chassis flex.

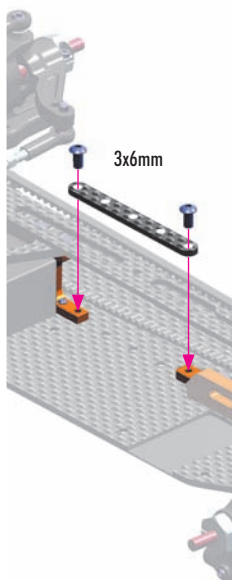

3

Attach the graphite reinforcement plate from the bottom so the chassis is now part of the inline chassis flex.

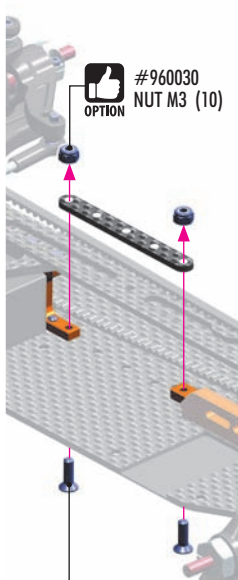

4

Attach the graphite reinforcement plate from the bottom so the chassis is now part of the inline chassis flex and use also extra holes between the servo holder and motor mount for even extra reinforcement

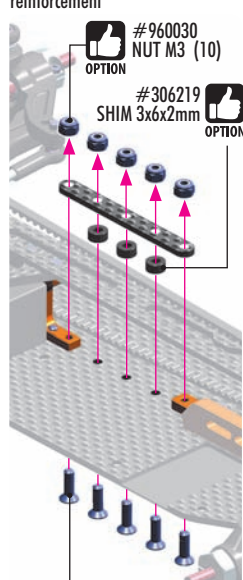

5

Use the linkage - mounted from the top - for inline chassis reinforcement. By using the linkage, the chassis stays stiff in the inline direction, but flexes to the sides.

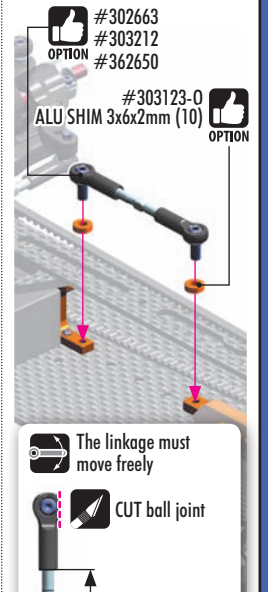

#306531
BRASS CHASSIS STIFFENER



#903308
HEX SCREW SFH
M3x8 (10)



#903308
HEX SCREW SFH
M3x8 (10)

The linkage must move freely



CUT ball joint



CUT ball joint



The ball joints must be modified (cutted) in order to prevent ball joints touching the belt.

7. FINAL ASSEMBLY

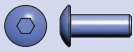

902308
SH M3x8



Adjust the motor so the pinion meshes with the spur gear properly. Make sure the gear mesh is not too tight.

There should be a small amount of play between the teeth of the pinion gear and the spur gear.

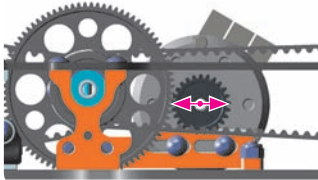

3x2.5mm set screw
(#901302)
(NOT INCLUDED)

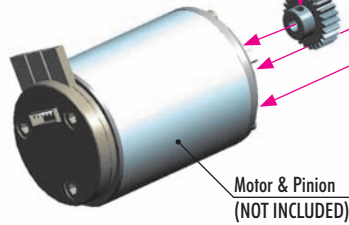

Motor & Pinion
(NOT INCLUDED)



TIP Some motors do not have a chamfer on the motor housing. If your motor does not have a chamfer on the housing and you want to use a small pinion, the motor may touch the top deck. Use a moto-tool with grinding bit or file to remove material from the top-deck; this will allow the motor to be moved closer to the spur gear.

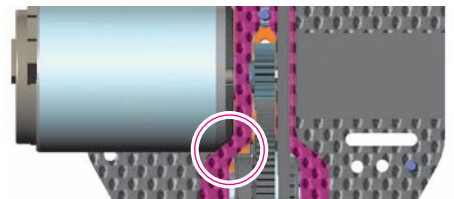

#303061
GRAPHITE MOTOR GUARD



#306410-0
ALU FAN MOUNT



GEARING ADJUSTMENT



903308
SFH M3x8



NOTE: In case the antenna tube does not hold the antenna properly, apply a small drop of the CA glue to the outside end of the antenna tube while inserting it into the holder. Make sure not to apply glue to the inside of the antenna tube, or the antenna wire may get permanently stuck.



Feed the receiver wire into the antenna tube

Receiver
(NOT INCLUDED)

FRONT

Speed Controller
(NOT INCLUDED)

Double-sided Tape
HUDY #107875
(NOT INCLUDED)

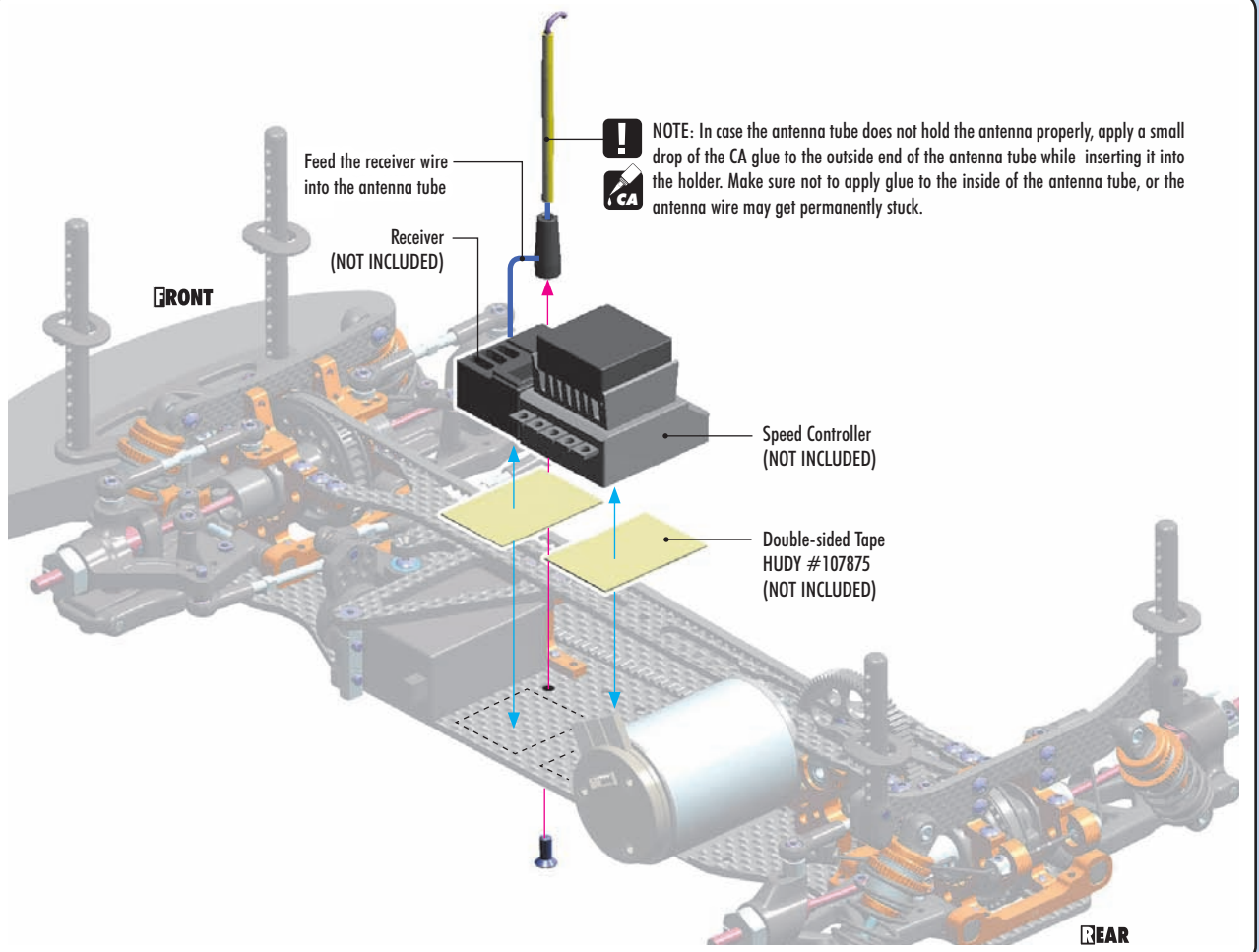

REAR

7. FINAL ASSEMBLY



903306
SFH M3x6

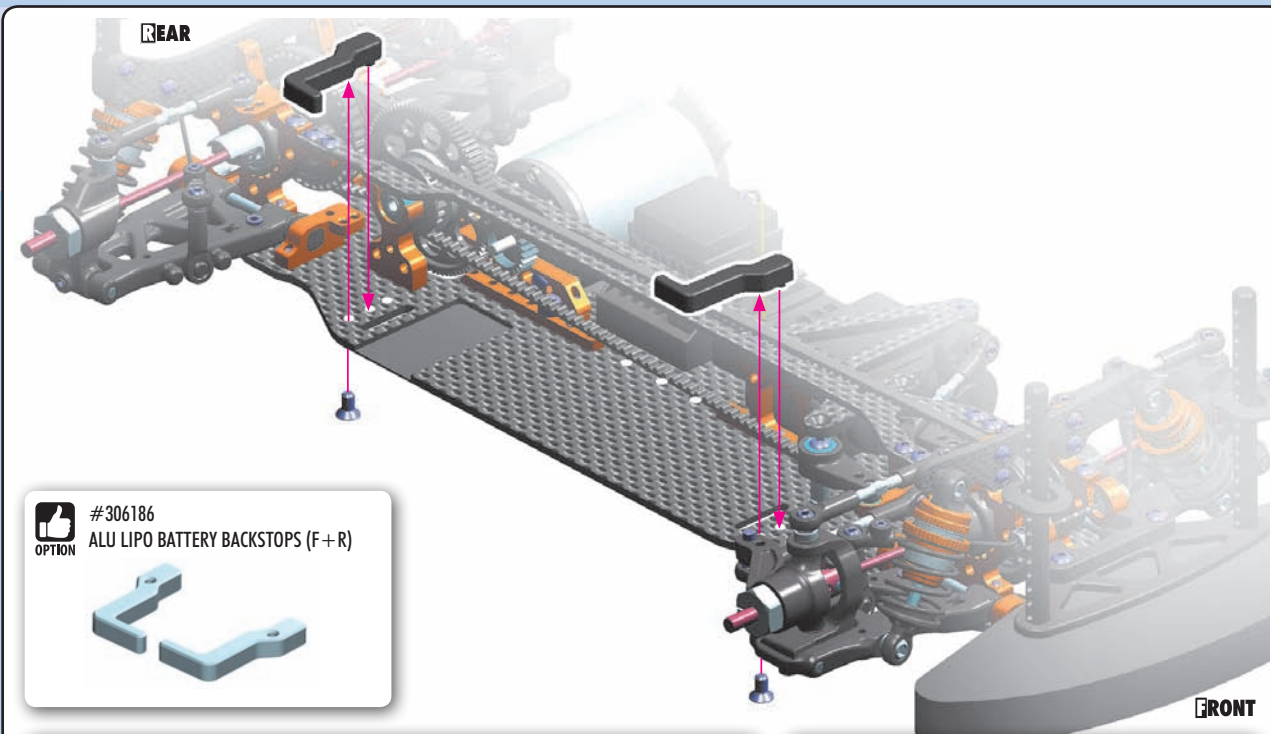

#306186
ALU LIPO BATTERY BACKSTOPS (F+R)

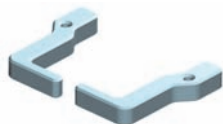

#306191
T4 GRAPHITE + ALU FULLY
ADJUSTABLE BATTERY HOLDER

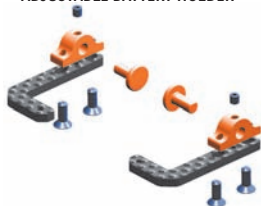

#306194
T4 GRAPHITE + BRASS FULLY
ADJUSTABLE BATTERY HOLDER

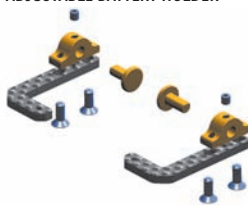

TIP Using the optional stand and shims with screw allows adjustment of battery position, which has a direct influence on balance.

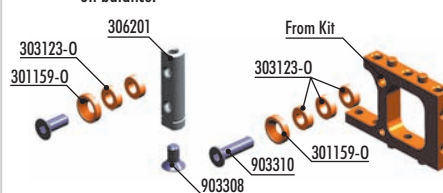

960140
N M4

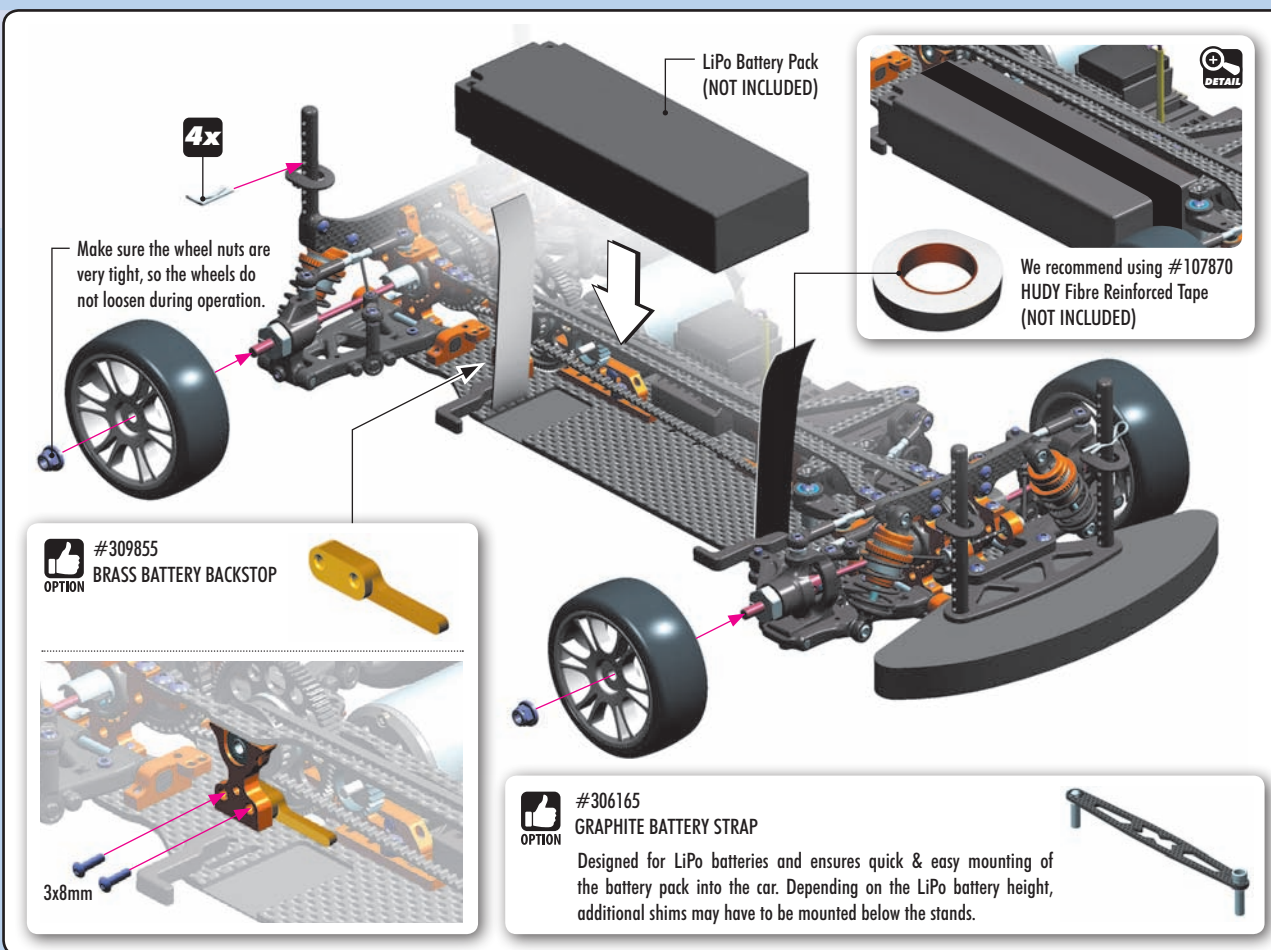

4x

Make sure the wheel nuts are very tight, so the wheels do not loosen during operation.

LiPo Battery Pack
(NOT INCLUDED)

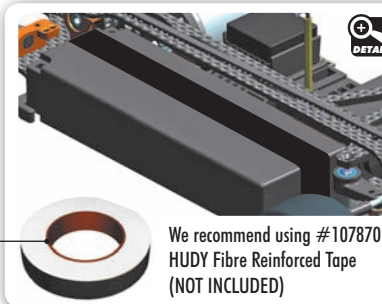

#309855
BRASS BATTERY BACKSTOP

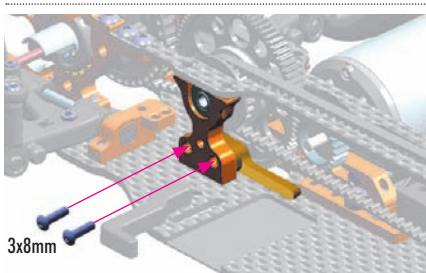

#306165
GRAPHITE BATTERY STRAP

Designed for LiPo batteries and ensures quick & easy mounting of the battery pack into the car. Depending on the LiPo battery height, additional shims may have to be mounted below the stands.





www.teamxray.com

XRAY EUROPE

XRAY, K VÝSTAVISKU 6992, 91101 TRENCIN, SLOVAKIA, EUROPE
 PHONE: +421-32-740 11 00, FAX: +421-32-740 11 09, info@teamxray.com

XRAY USA

RC AMERICA, 2030 Century Center Blvd #15, Irving, TX 75062, USA
 PHONE: 214-744-2400, FAX: 214-744-2401, xray@rcamerica.com

