

# Walking Onions: Scaling Anonymity Networks while Protecting Users

**Chelsea H. Komlo**<sup>1</sup>, Nick Mathewson<sup>2</sup>, Ian Goldberg<sup>1</sup>

<sup>1</sup> University of Waterloo

<sup>2</sup> The Tor Project

USENIX Security Symposium, 13 August 2020



Cryptography, Security, and Privacy  
— Research Group @ uWaterloo —

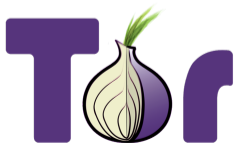

# Tor is a privacy-enhancing tool to use the Internet privately and circumvent censorship.

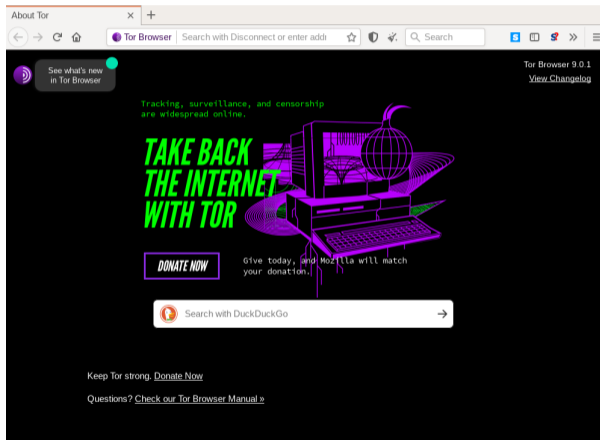

# Current Tor Path Selection and Circuit Extension

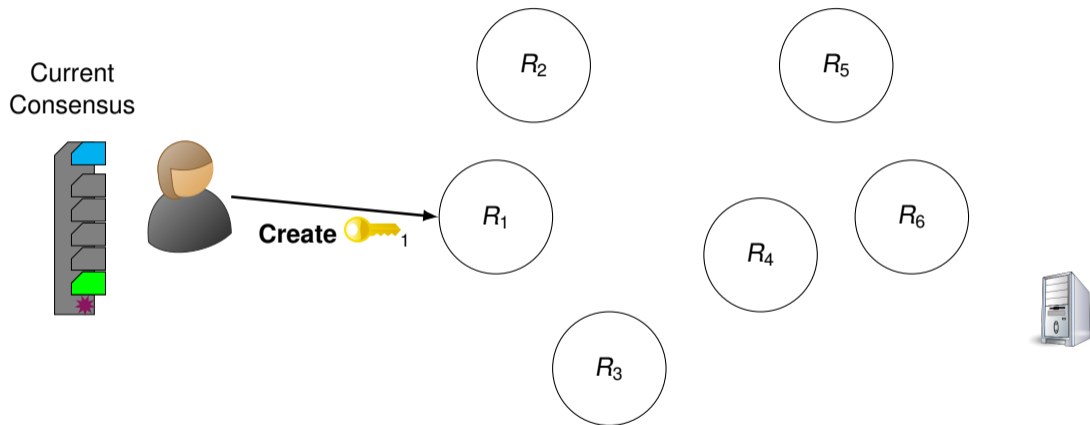

# Current Tor Path Selection and Circuit Extension

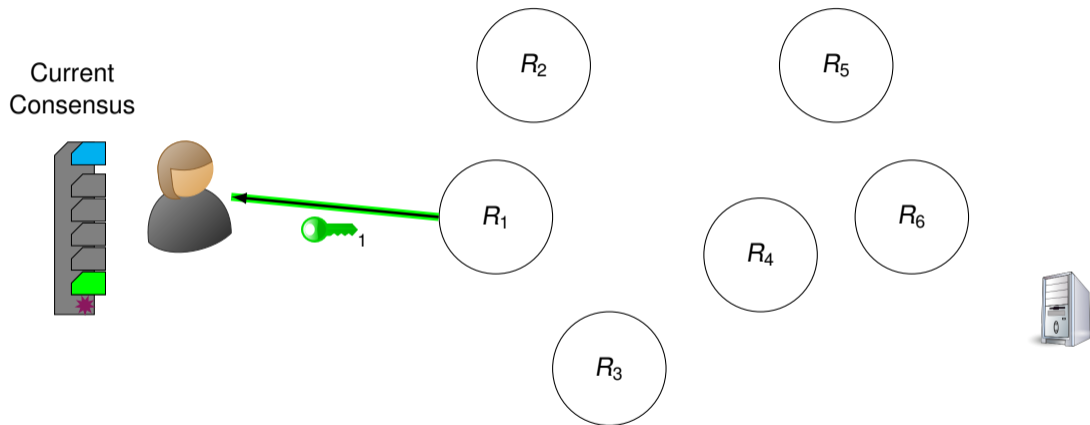

# Current Tor Path Selection and Circuit Extension

Current  
Consensus

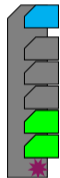

Extend  $R_5$  

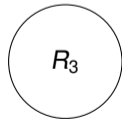
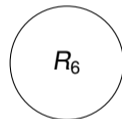
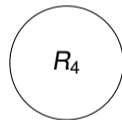
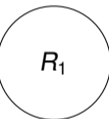
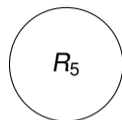
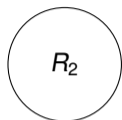

# Current Tor Path Selection and Circuit Extension

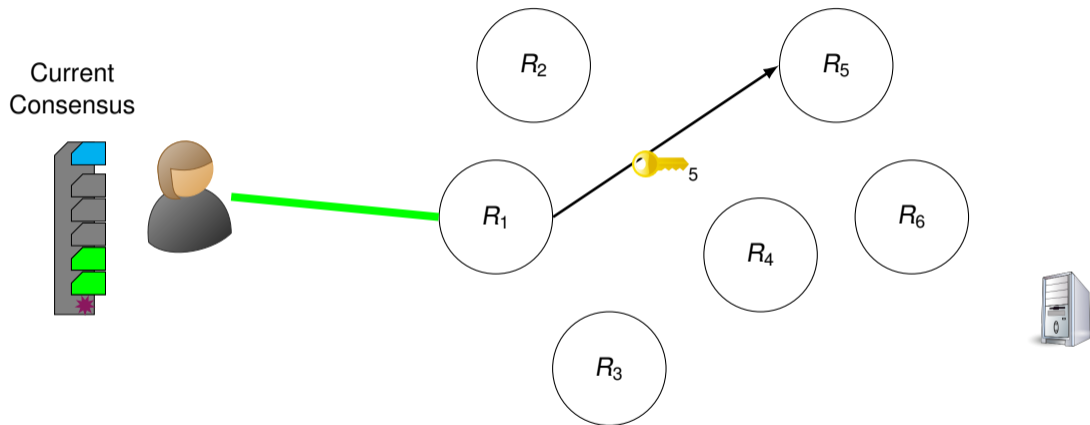

# Current Tor Path Selection and Circuit Extension

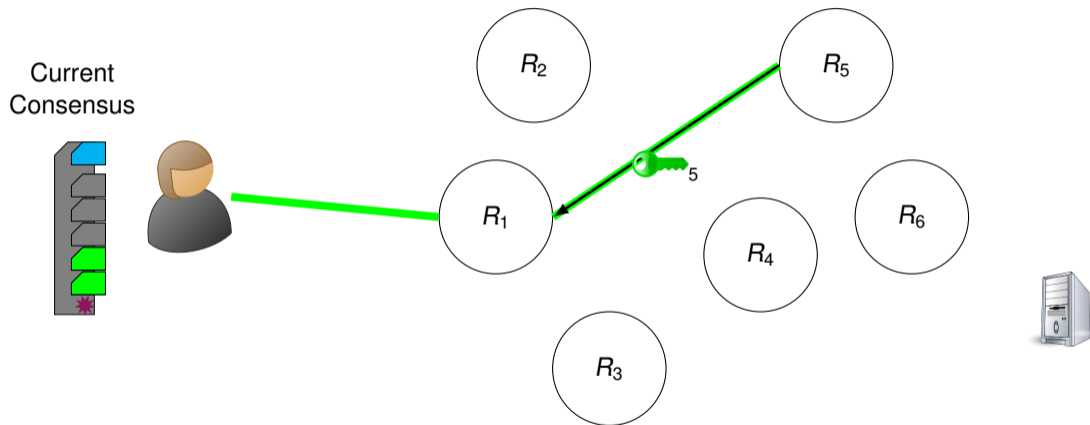

# Current Tor Path Selection and Circuit Extension

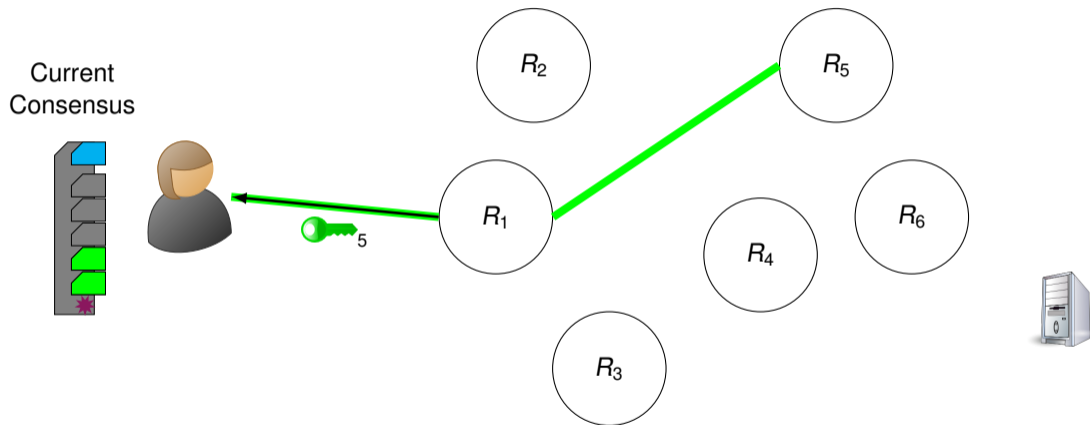



# Current Tor Path Selection and Circuit Extension

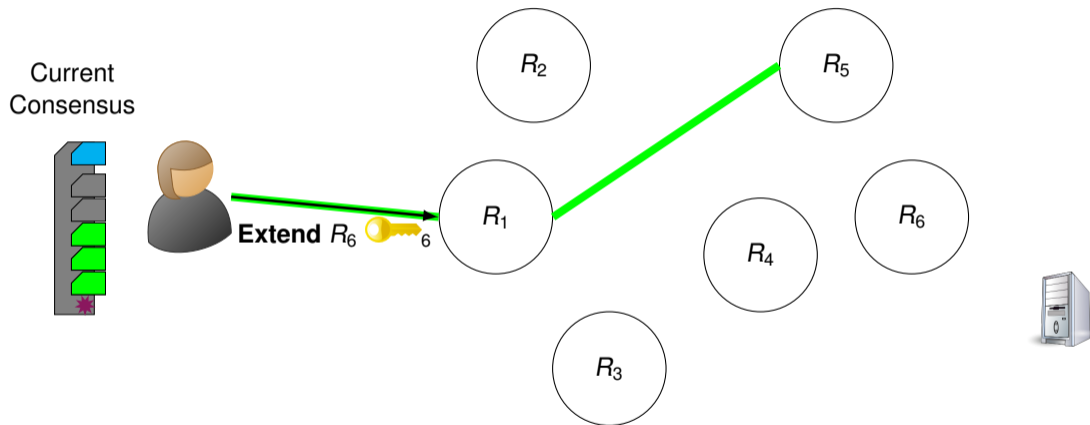

# Current Tor Path Selection and Circuit Extension

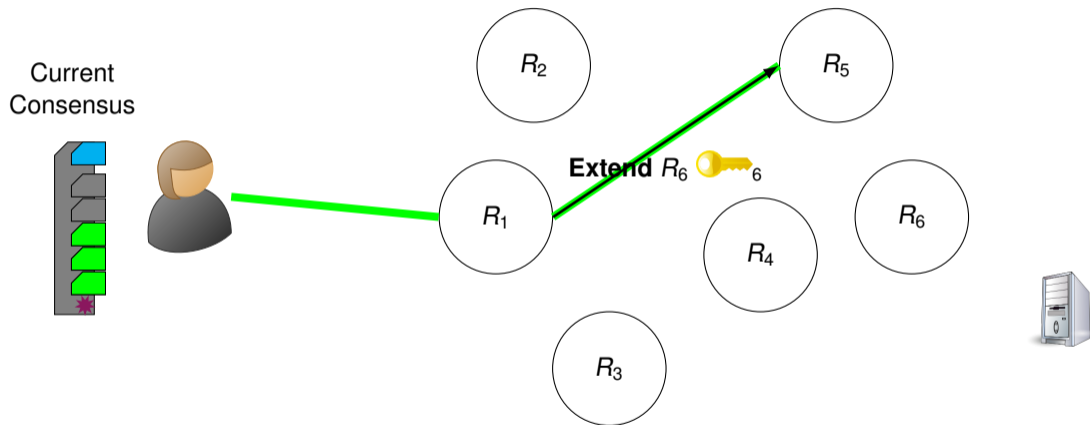

# Current Tor Path Selection and Circuit Extension

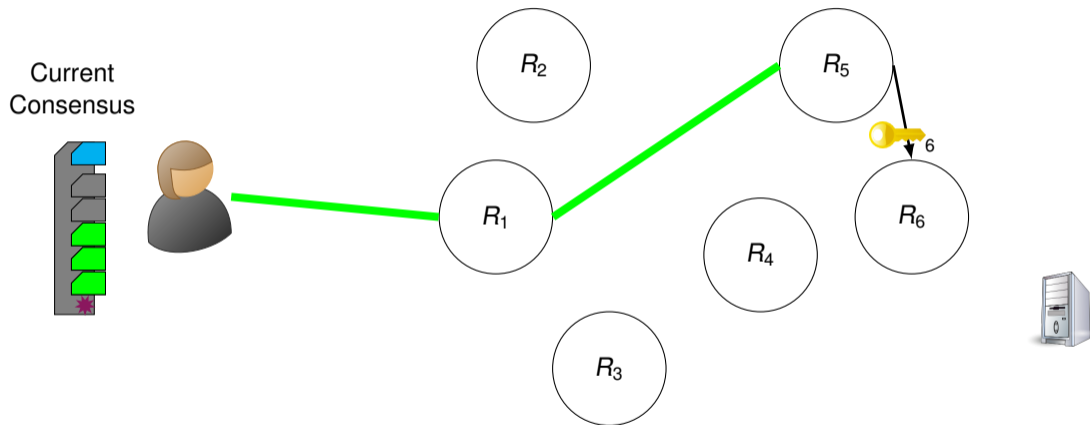

# Current Tor Path Selection and Circuit Extension

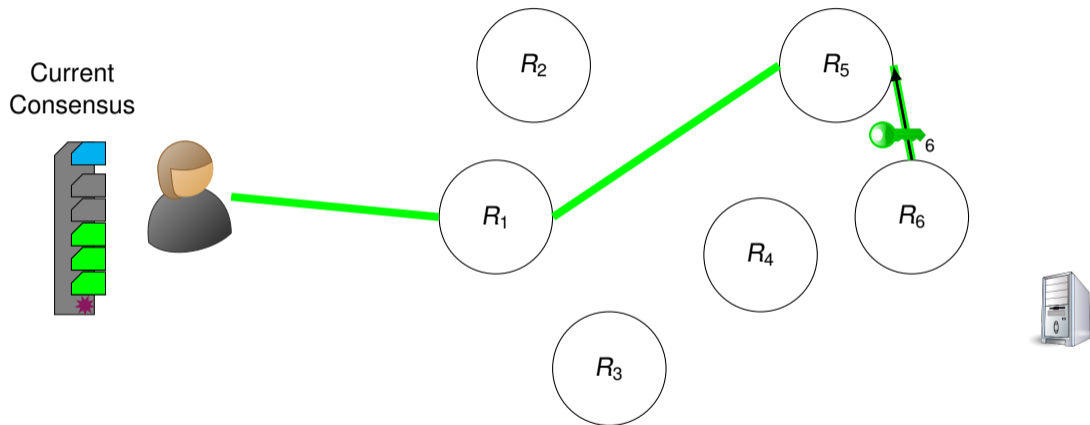

# Current Tor Path Selection and Circuit Extension

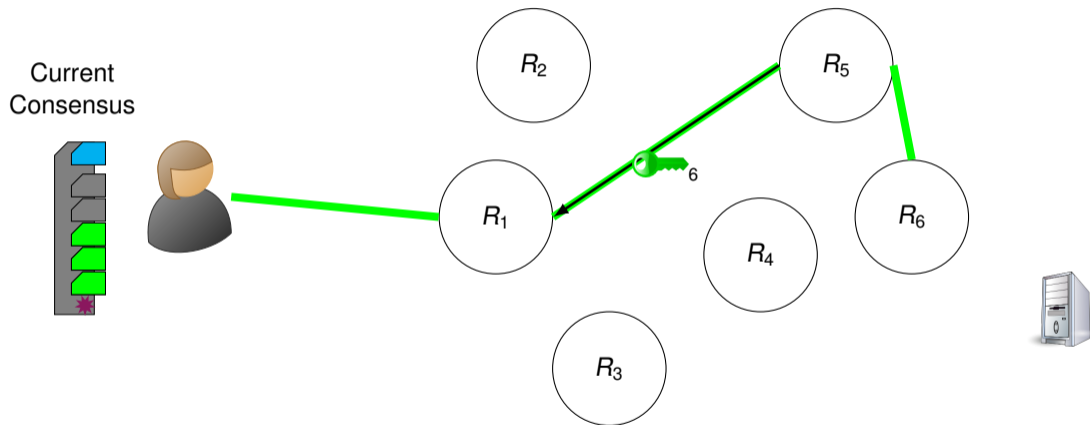

# Current Tor Path Selection and Circuit Extension

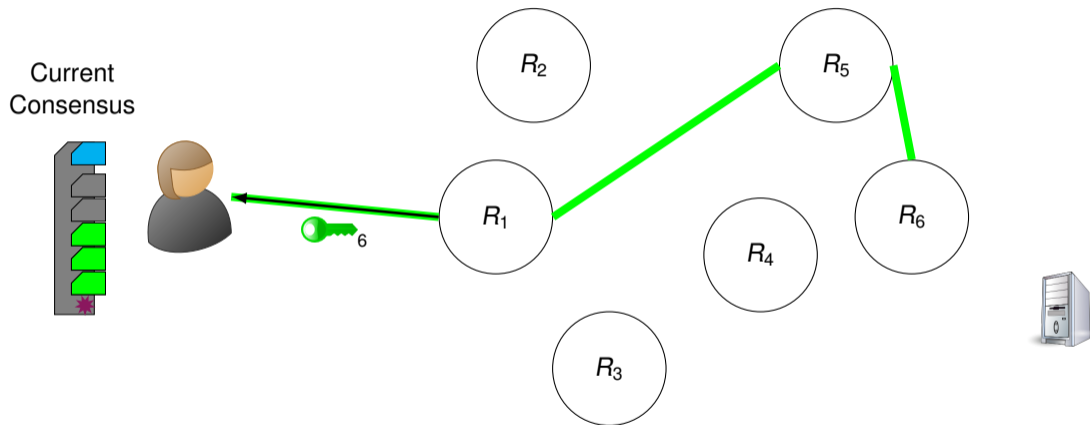

# Current Tor Path Selection and Circuit Extension

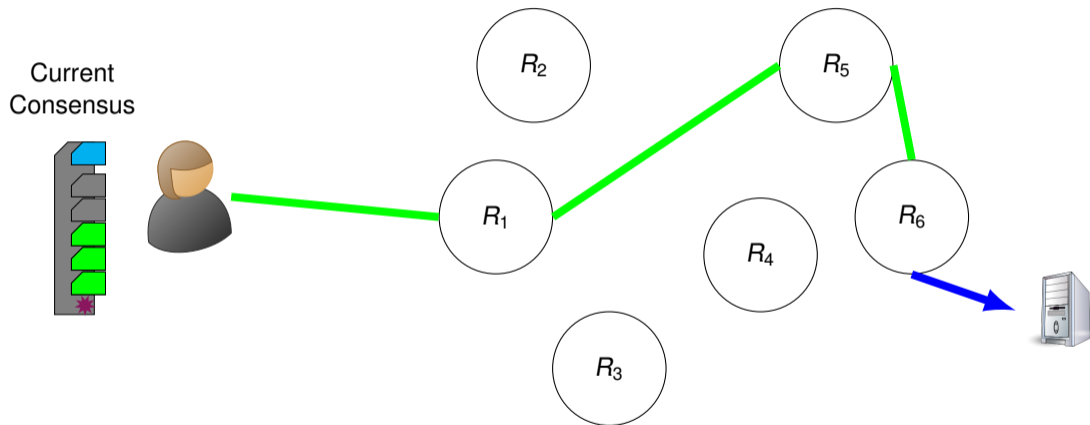

# Tor Security Model: Security over Scalability

- ▶ **Epistemic Attacks:** Users with different views of the network can be distinguished by their relay selection.



# Tor Security Model: Security over Scalability

- ▶ **Epistemic Attacks:** Users with different views of the network can be distinguished by their relay selection.

**Tor's Protection:** All clients to maintain an up-to-date consensus copy.

# Tor Security Model: Security over Scalability

- ▶ **Epistemic Attacks:** Users with different views of the network can be distinguished by their relay selection.

**Tor's Protection:** All clients to maintain an up-to-date consensus copy.

- ▶ **Route-Capture Attacks:** When an adversary can influence users' relay selection.

# Tor Security Model: Security over Scalability

- ▶ **Epistemic Attacks:** Users with different views of the network can be distinguished by their relay selection.

**Tor's Protection:** All clients to maintain an up-to-date consensus copy.

- ▶ **Route-Capture Attacks:** When an adversary can influence users' relay selection.

**Tor's Protection:** Clients verify relay responses using signing keys in the consensus.

# What Contributions Does Walking Onions Make?

- ▶ **Constant-Size Client Overhead.** Client bandwidth overhead remains constant even as new relays join (or at worst logarithmic).

# What Contributions Does Walking Onions Make?

- ▶ **Constant-Size Client Overhead.** Client bandwidth overhead remains constant even as new relays join (or at worst logarithmic).
- ▶ **Maintains Tor's Existing Security Model.** One variant has no change, the other a slight loosening of forward secrecy (for path selection, not content).

# What Contributions Does Walking Onions Make?

- ▶ **Constant-Size Client Overhead.** Client bandwidth overhead remains constant even as new relays join (or at worst logarithmic).
- ▶ **Maintains Tor's Existing Security Model.** One variant has no change, the other a slight loosening of forward secrecy (for path selection, not content).
- ▶ **Immediate Performance Improvements.** Demonstrates improvements at networks the size of Tor today.

# What Contributions Does Walking Onions Make?

- ▶ **Constant-Size Client Overhead.** Client bandwidth overhead remains constant even as new relays join (or at worst logarithmic).
- ▶ **Maintains Tor's Existing Security Model.** One variant has no change, the other a slight loosening of forward secrecy (for path selection, not content).
- ▶ **Immediate Performance Improvements.** Demonstrates improvements at networks the size of Tor today.
- ▶ **Generally Applicable.** Aspects of Walking Onions apply to network designs beyond Tor.

# What Improvements Does Walking Onions Make?

- ▶ How to represent relay information to enable oblivious selection and individual verification?



# What Improvements Does Walking Onions Make?

- ▶ How to represent relay information to enable oblivious selection and individual verification?
- ▶ How to build paths using oblivious relay selection?

# What Improvements Does Walking Onions Make?

- ▶ How to represent relay information to enable oblivious selection and individual verification?
- ▶ How to build paths using oblivious relay selection?
- ▶ How to perform more efficient circuit construction?

# What improvements does Walking Onions make?

- ▶ **How to represent relay information to enable oblivious selection and individual verification?**

# New Data Structure: Seperable Network Index Proof (SNIP)

Current  
Consensus

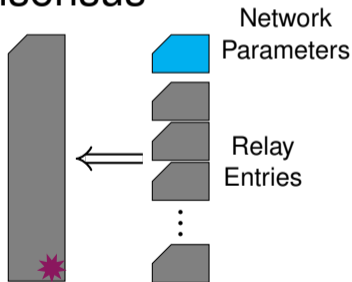

# New Data Structure: Seperable Network Index Proof (SNIP)

Current  
Consensus

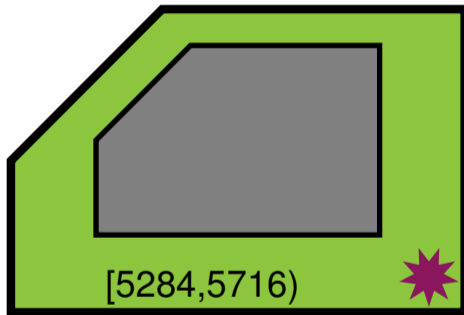
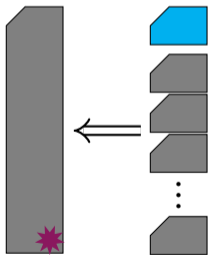

# New Data Structure: Seperable Network Index Proof (SNIP)

Current  
Consensus

SNIPs

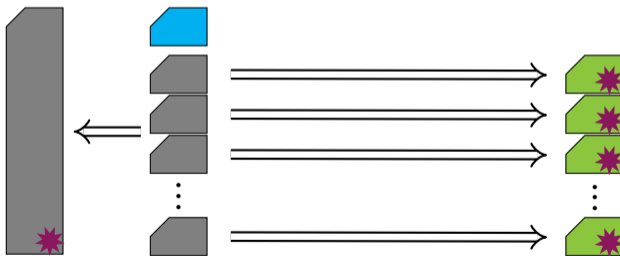

# ENDIVE: Efficient Network Directory with Independently Verifiable Entries

Current  
Consensus

SNIPs

ENDIVE

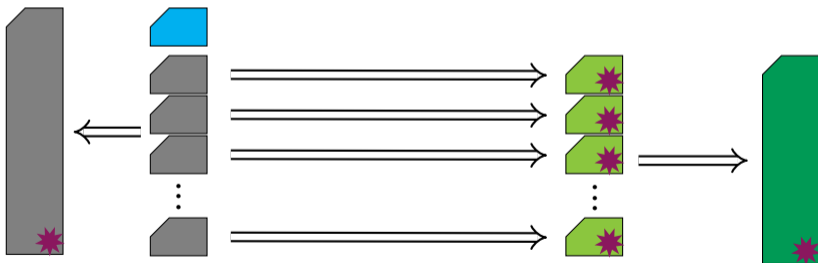

# ENDIVE: Efficient Network Directory with Independently Verifiable Entries

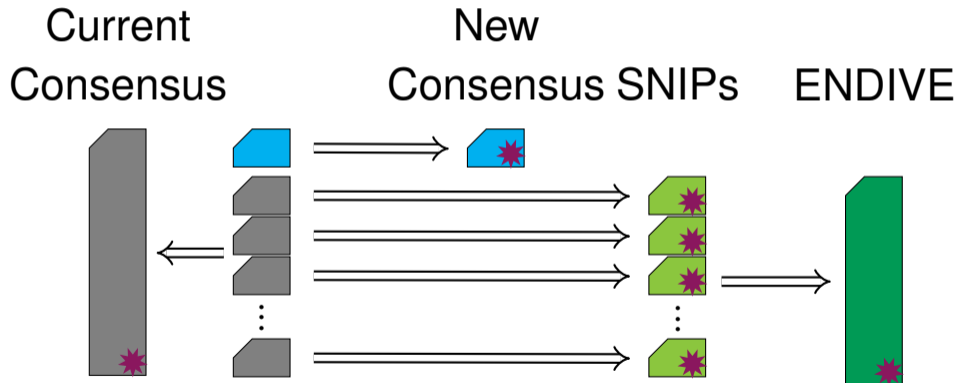



# What improvements does Walking Onions make?

- ▶ How to represent relay information to enable oblivious selection and individual verification?
- ▶ **How to build paths using oblivious relay selection?**

# Telescoping Walking Onions

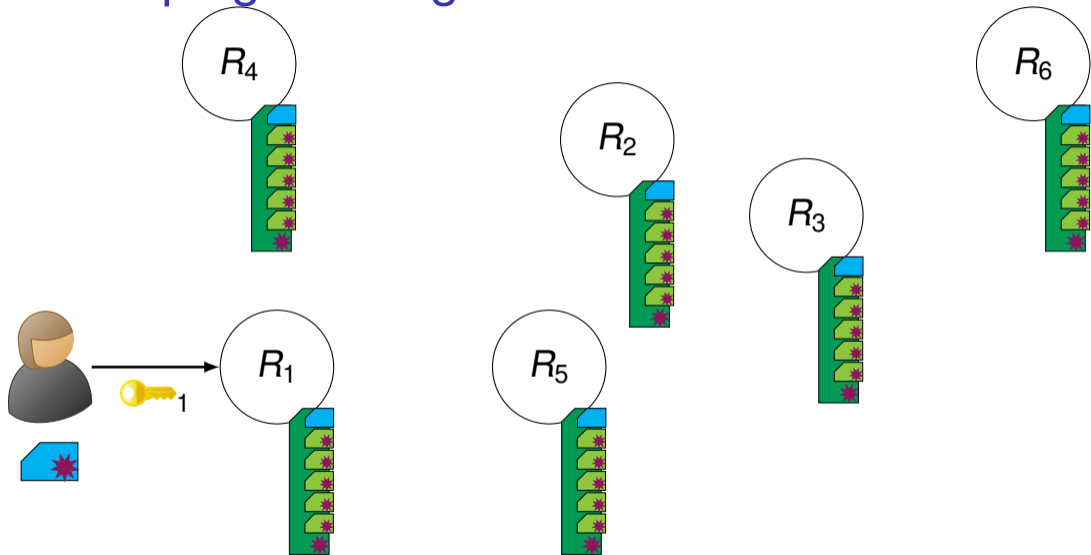

# Telescoping Walking Onions

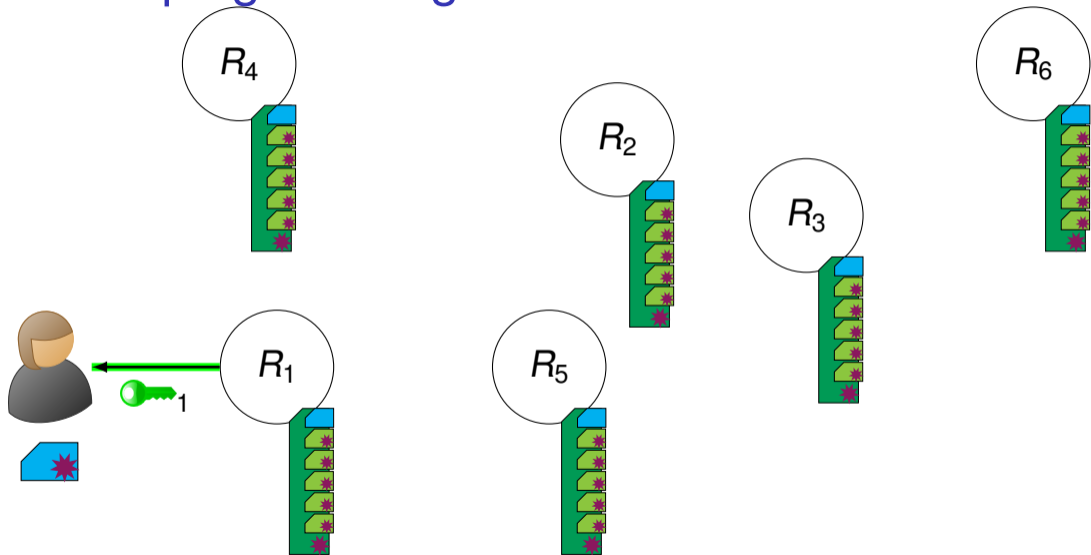

# Telescoping Walking Onions

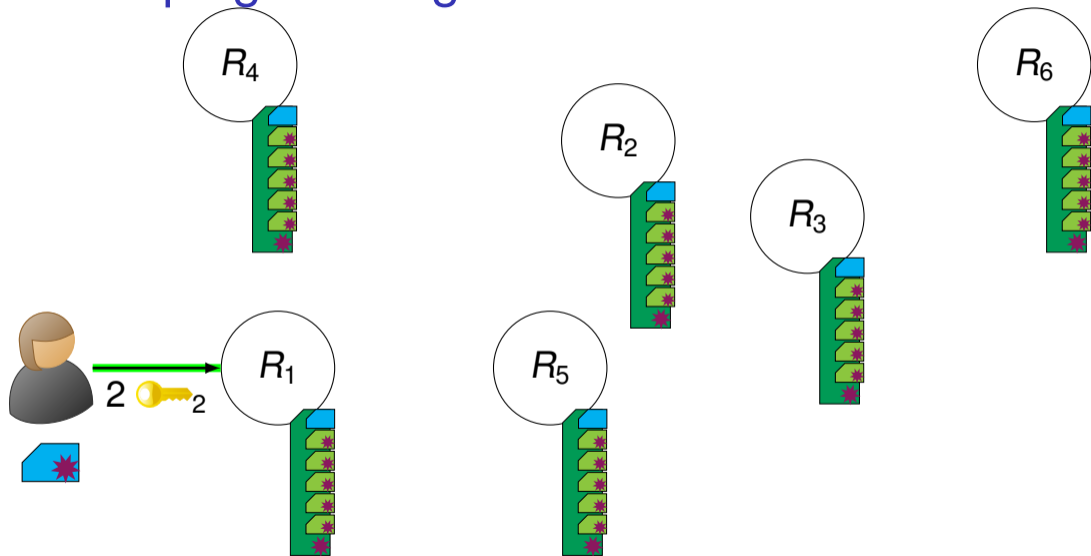

# Telescoping Walking Onions

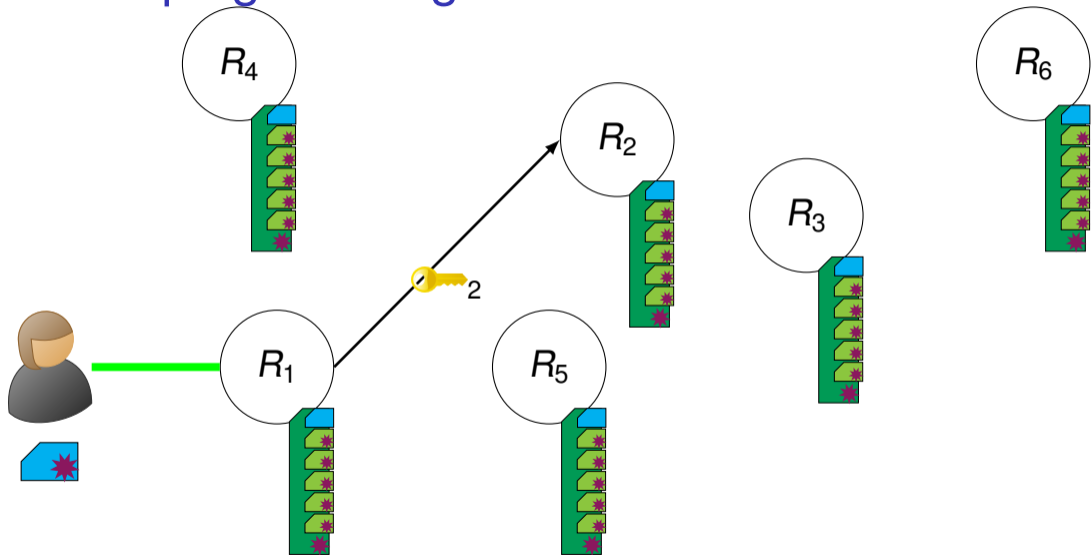

# Telescoping Walking Onions

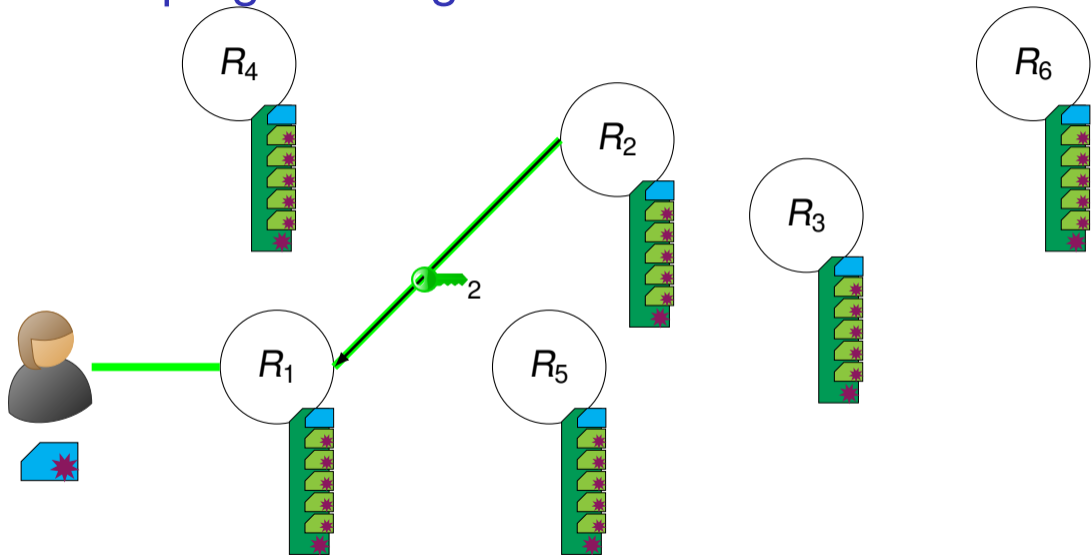

# Telescoping Walking Onions

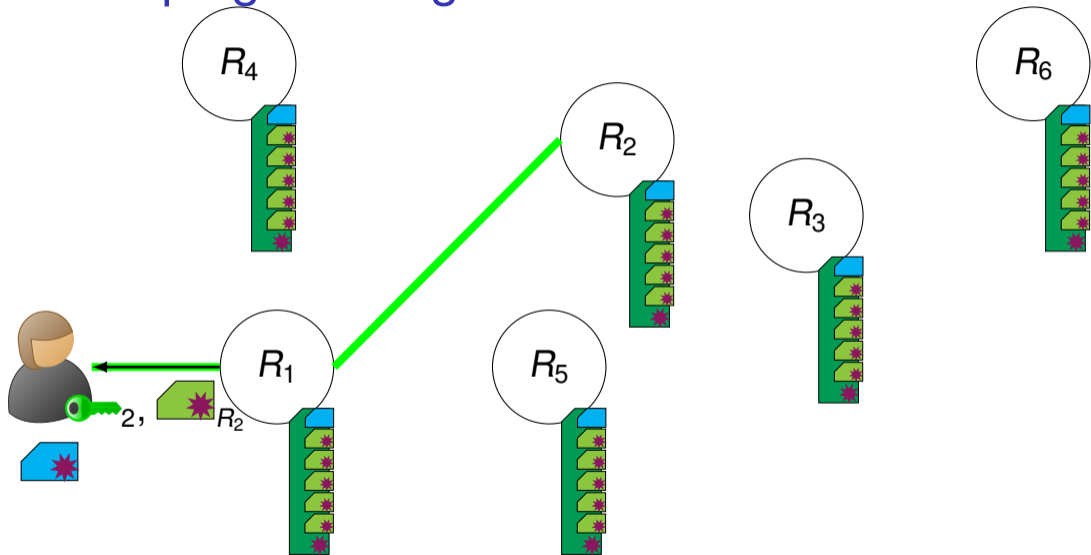

# Telescoping Walking Onions

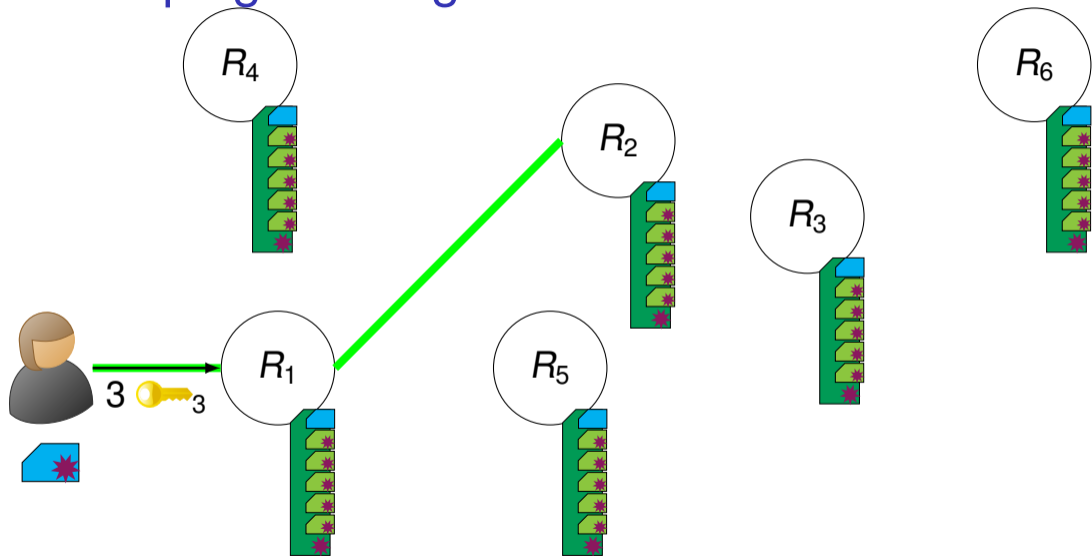



# Telescoping Walking Onions

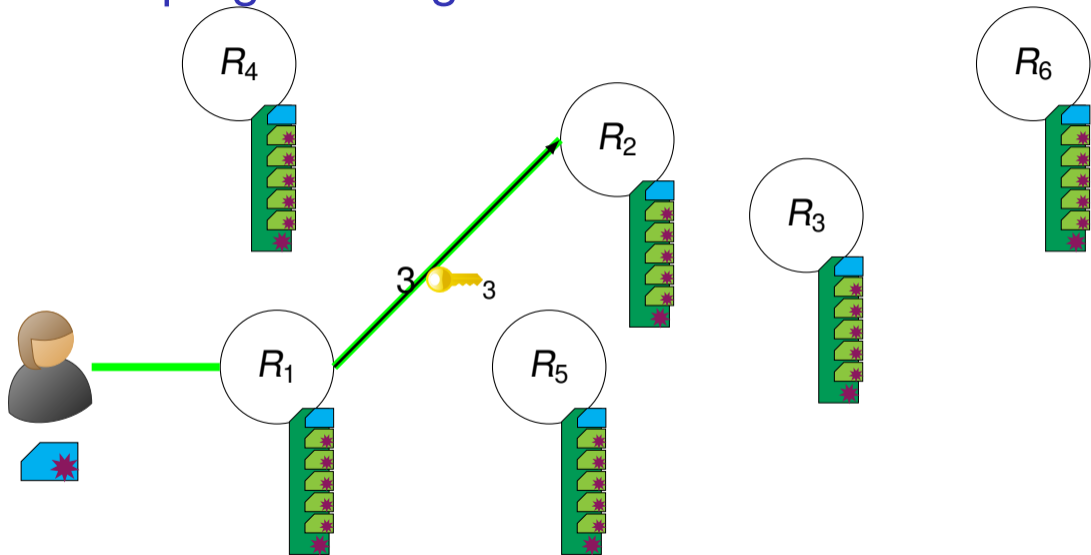

# Telescoping Walking Onions

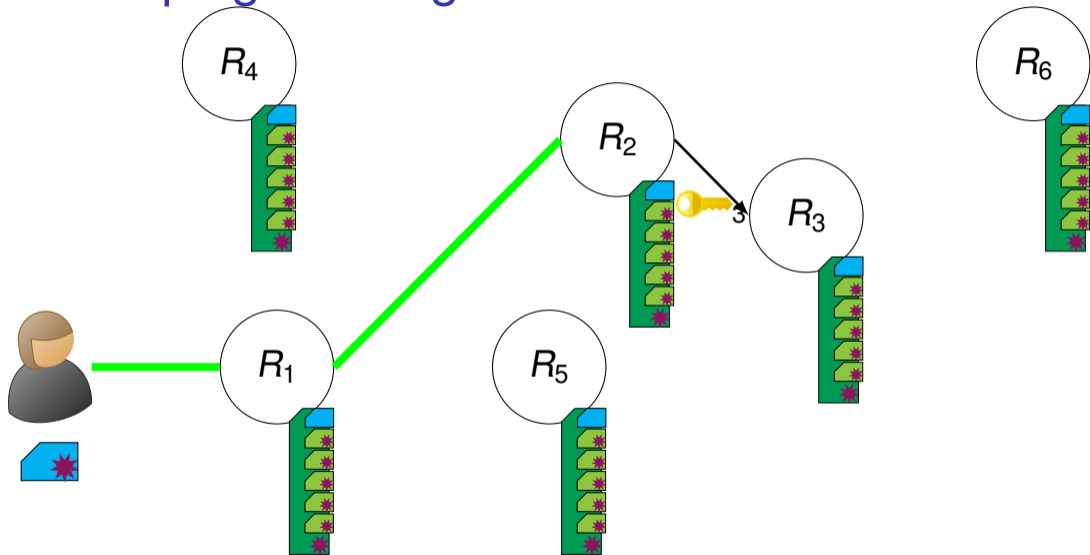

# Telescoping Walking Onions

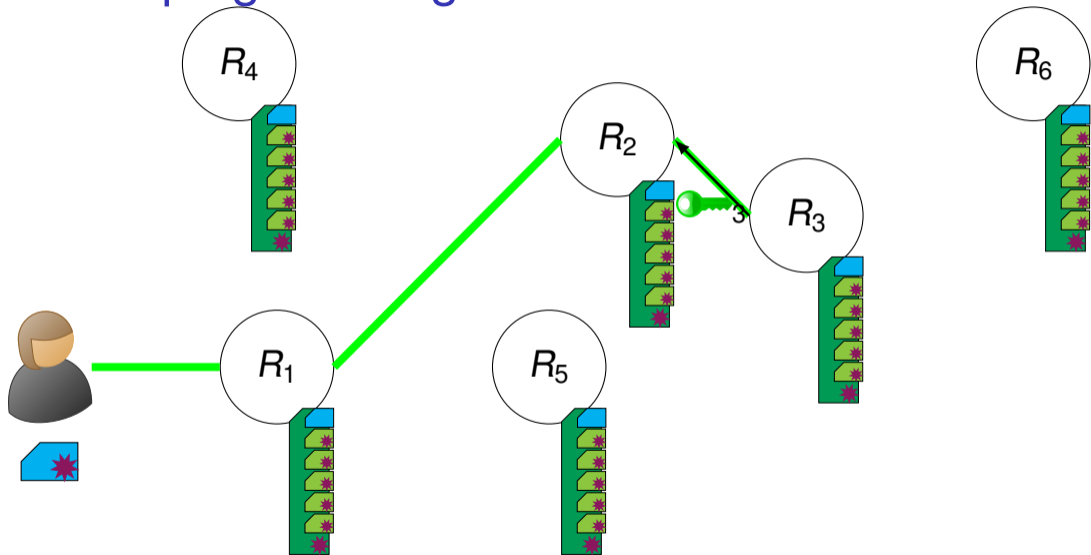

# Telescoping Walking Onions

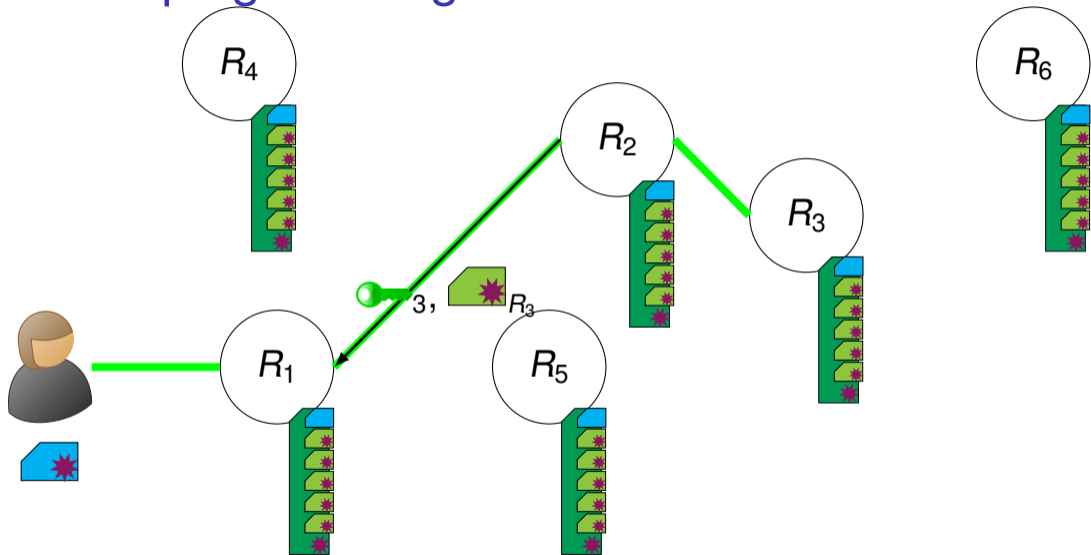

# Telescoping Walking Onions

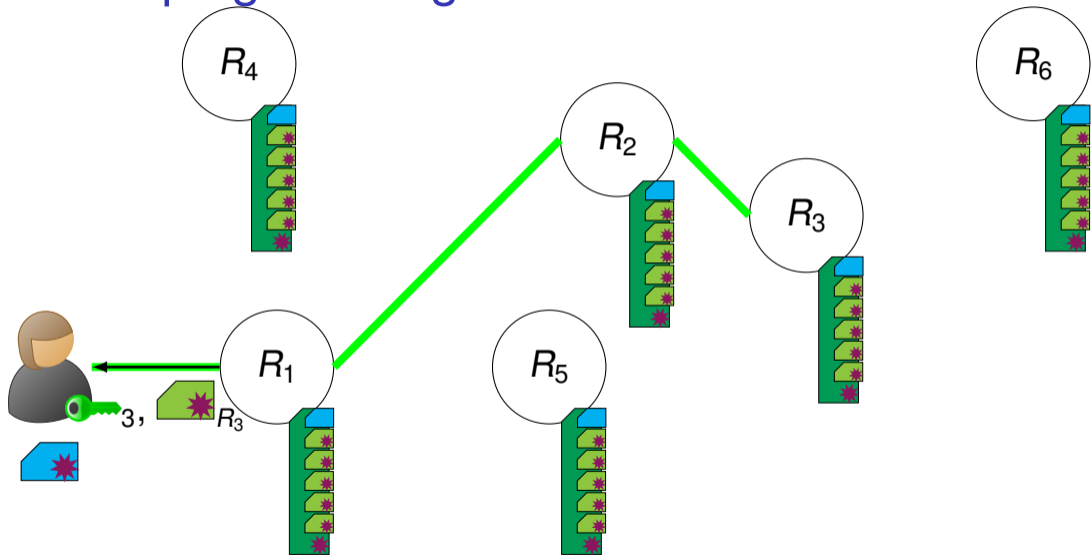

# What improvements does Walking Onions make?

- ▶ How to represent relay information to enable oblivious selection and individual verification?
- ▶ How to build paths using oblivious relay selection?
- ▶ **How to perform more efficient circuit construction?**

# Single-Pass Walking Onions

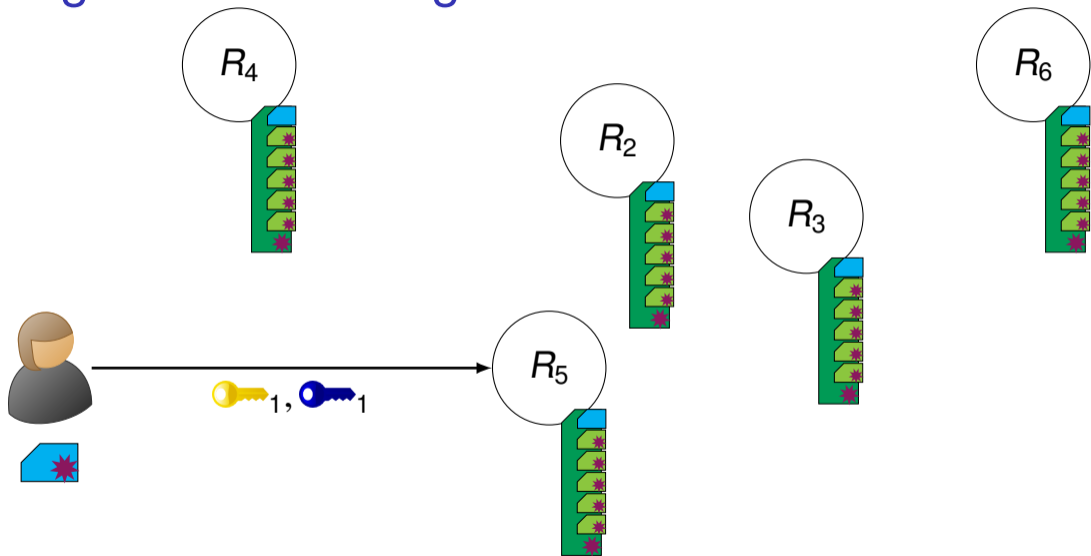

# Single-Pass Walking Onions

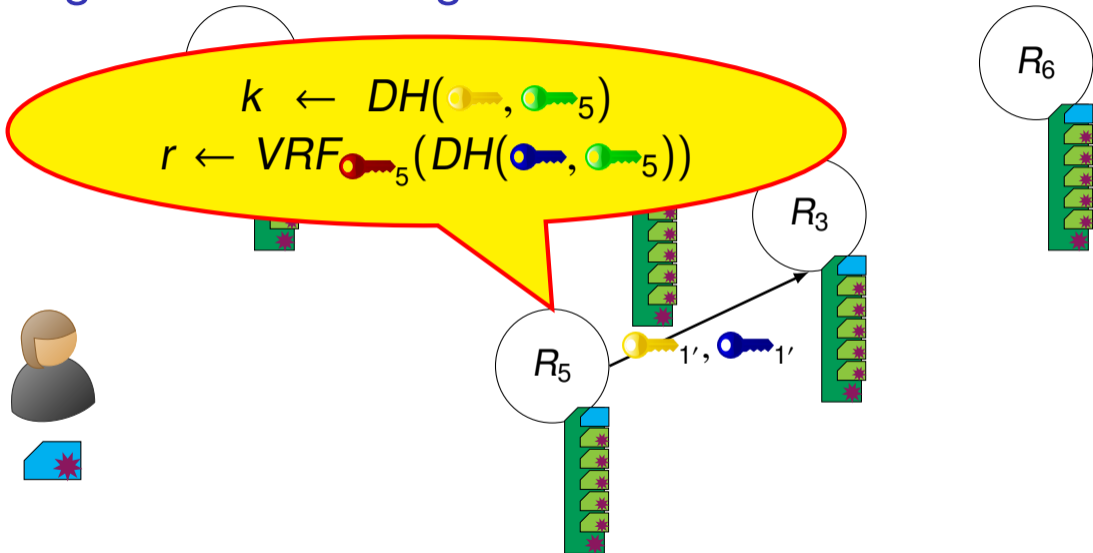



# Single-Pass Walking Onions

$$k' \leftarrow \text{DH}(\text{key}'_1, \text{key}_3)$$
$$r' \leftarrow \text{VRF}_{\text{key}_3}(\text{DH}(\text{key}'_1, \text{key}_3))$$

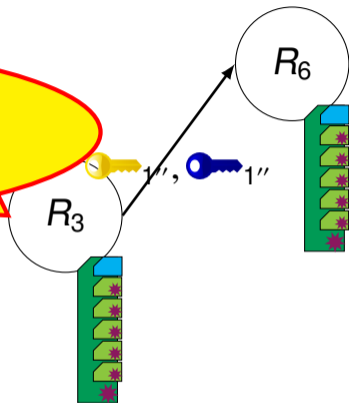
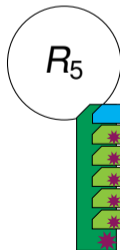

# Single-Pass Walking Onions

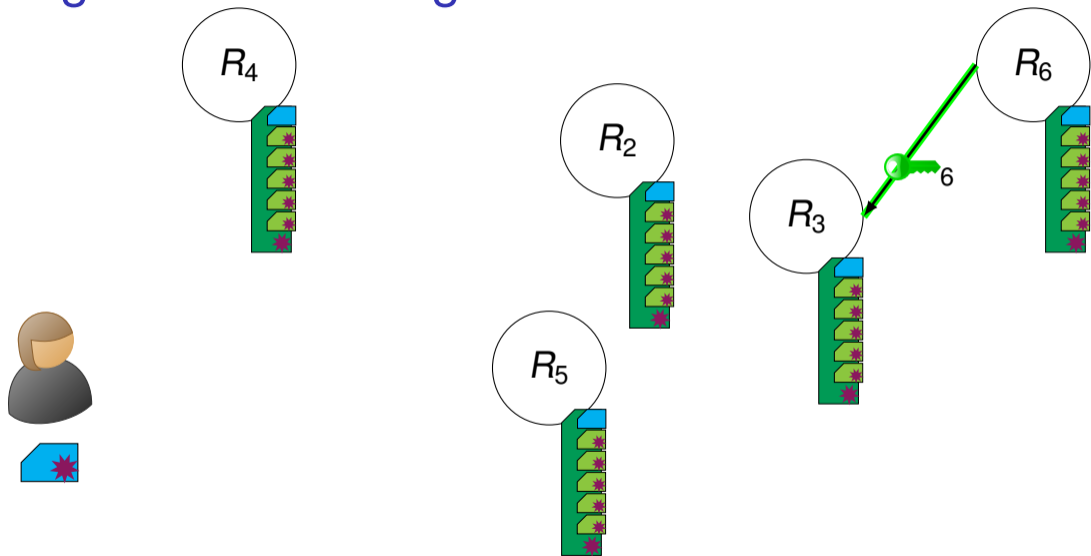

# Single-Pass Walking Onions

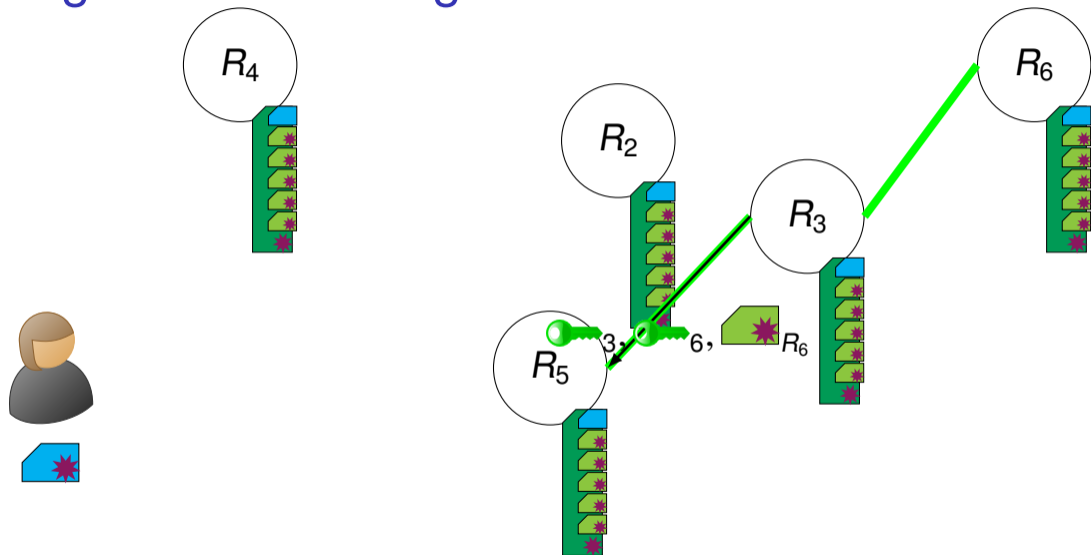

# Single-Pass Walking Onions

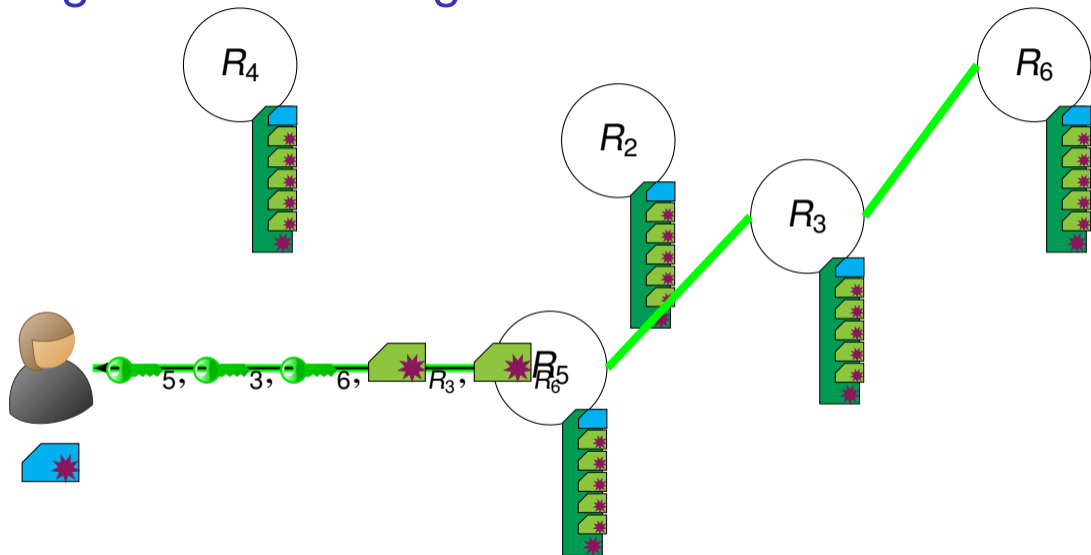

# Performance Evaluation

# Bandwidth Results for Tor Relays

Relay total bytes each

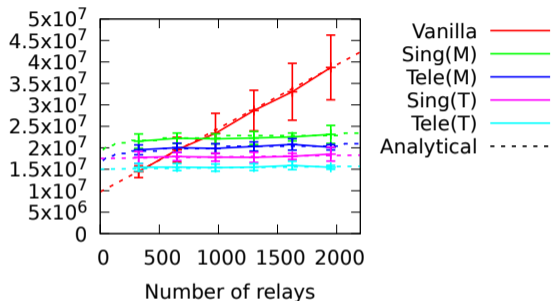

Relay total bytes each

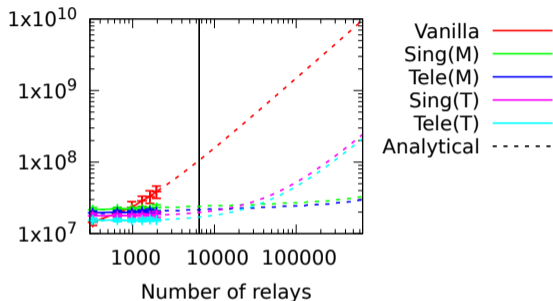

# Bandwidth Results for Tor Relays

Relay total bytes each

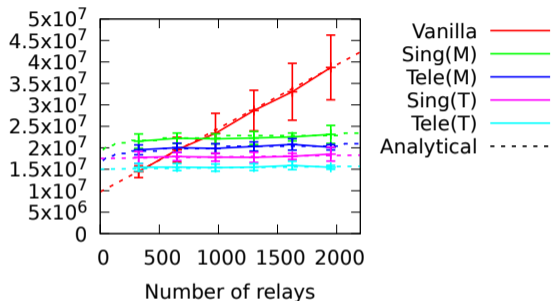

Relay total bytes each

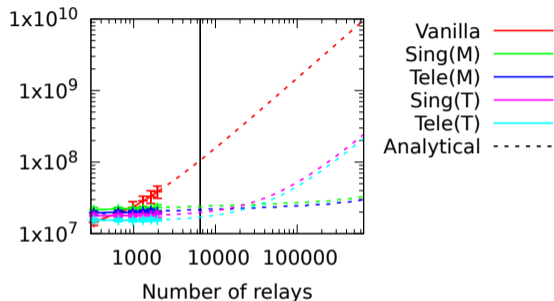

- ▶ Walking Onions requires 4–6 times less bandwidth than Vanilla Onion Routing at a network the size of Tor today.

# Bandwidth Results for Tor Relays

Relay total bytes each

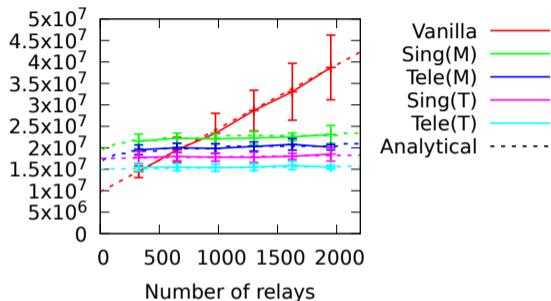

Relay total bytes each

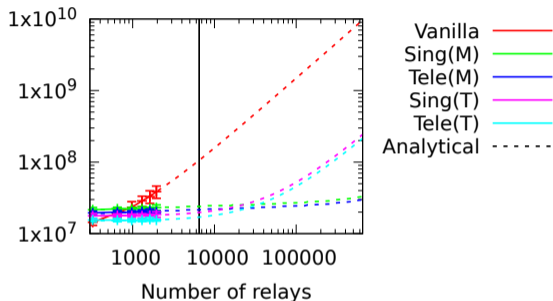

- ▶ Walking Onions requires 4–6 times less bandwidth than Vanilla Onion Routing at a network the size of Tor today.
- ▶ Improvement of 25–40 times less bandwidth at a network 10 times the size of Tor.



# Bandwidth Results for Tor Clients

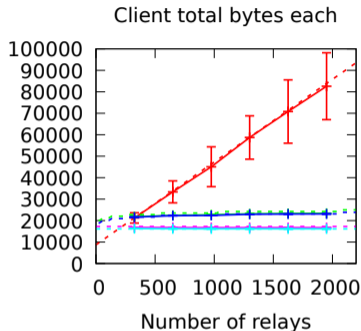

Vanilla —  
Sing(M) —  
Tele(M) —  
Sing(T) —  
Tele(T) —  
Analytical - - -

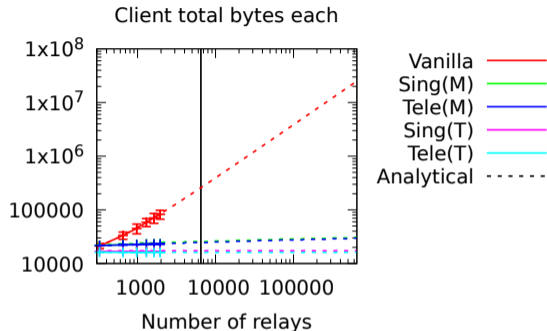

Vanilla —  
Sing(M) —  
Tele(M) —  
Sing(T) —  
Tele(T) —  
Analytical - - -

# Bandwidth Results for Tor Clients

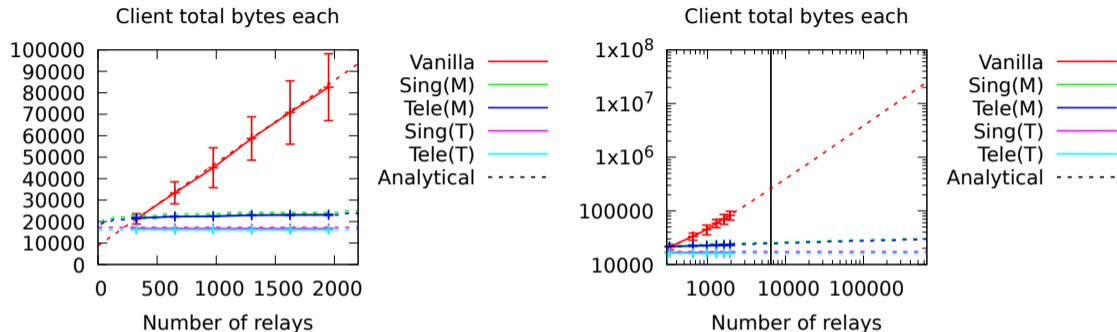

- ▶ Clients in Walking Onions save 10–15 times the bandwidth over Vanilla Onion Routing in a network the size of Tor today.

# Bandwidth Results for Tor Clients

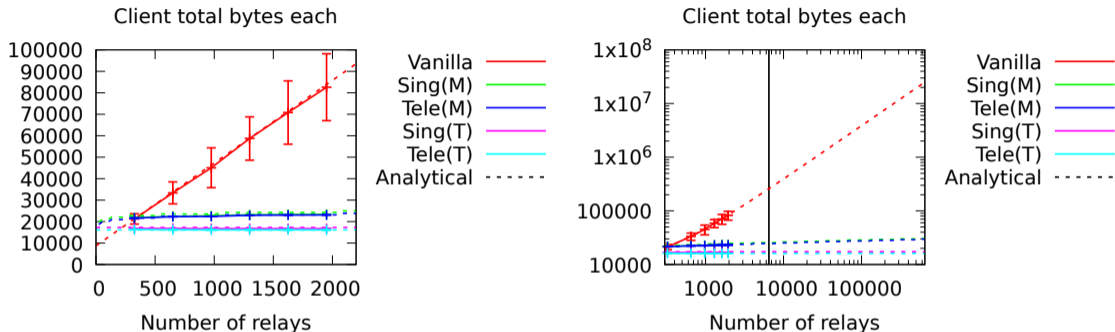

- ▶ Clients in Walking Onions save 10–15 times the bandwidth over Vanilla Onion Routing in a network the size of Tor today.
- ▶ In a network 10 times the size of Tor, Walking Onions saves clients 90–150 times the bandwidth over Vanilla.

# Takeaways

- ▶ The design of Tor today imposes impractical overheads to clients as the network scales.

---

Find our paper and artifact at <https://crysp.uwaterloo.ca/software/walkingonions>

# Takeaways

- ▶ The design of Tor today imposes impractical overheads to clients as the network scales.
- ▶ Walking Onions:

---

Find our paper and artifact at <https://crysp.uwaterloo.ca/software/walkingonions>

# Takeaways

- ▶ The design of Tor today imposes impractical overheads to clients as the network scales.
- ▶ Walking Onions:
  - ▶ Removes the per-relay bandwidth and storage cost to clients

---

Find our paper and artifact at <https://crysp.uwaterloo.ca/software/walkingonions>

# Takeaways

- ▶ The design of Tor today imposes impractical overheads to clients as the network scales.
- ▶ Walking Onions:
  - ▶ Removes the per-relay bandwidth and storage cost to clients
  - ▶ Offers the same security protections against epistemic and route capture attacks as prior designs that required a globally consistent view.

---

Find our paper and artifact at <https://crysp.uwaterloo.ca/software/walkingonions>

# Takeaways

- ▶ The design of Tor today imposes impractical overheads to clients as the network scales.
- ▶ Walking Onions:
  - ▶ Removes the per-relay bandwidth and storage cost to clients
  - ▶ Offers the same security protections against epistemic and route capture attacks as prior designs that required a globally consistent view.
- ▶ Tor has already begun the specification work to integrate Walking Onions into the Tor protocol.

---

Find our paper and artifact at <https://crysp.uwaterloo.ca/software/walkingonions>