



**IAR Embedded
Workbench**

C-SPY® Debugging Guide

for the Texas Instruments

MSP430 Microcontroller Family

COPYRIGHT NOTICE

© 2010-2021 IAR Systems AB.

No part of this document may be reproduced without the prior written consent of IAR Systems AB. The software described in this document is furnished under a license and may only be used or copied in accordance with the terms of such a license.

DISCLAIMER

The information in this document is subject to change without notice and does not represent a commitment on any part of IAR Systems. While the information contained herein is assumed to be accurate, IAR Systems assumes no responsibility for any errors or omissions.

In no event shall IAR Systems, its employees, its contractors, or the authors of this document be liable for special, direct, indirect, or consequential damage, losses, costs, charges, claims, demands, claim for lost profits, fees, or expenses of any nature or kind.

TRADEMARKS

IAR Systems, IAR Embedded Workbench, Embedded Trust, C-Trust, IAR Connect, C-SPY, C-RUN, C-STAT, IAR Visual State, IAR KickStart Kit, I-jet, I-jet Trace, I-scope, IAR Academy, IAR, and the logotype of IAR Systems are trademarks or registered trademarks owned by IAR Systems AB.

Microsoft and Windows are registered trademarks of Microsoft Corporation.

Texas Instruments is a registered trademark of Texas Instruments Corporation. MSP430 is a trademark of Texas Instruments Corporation.

Adobe and Acrobat Reader are registered trademarks of Adobe Systems Incorporated.

All other product names are trademarks or registered trademarks of their respective owners.

EDITION NOTICE

Eighth edition: March 2021

Part number: UCS430-8

This guide applies to version 7.x of IAR Embedded Workbench® for the Texas Instruments MSP430 microcontroller family.

Internal reference: M23, Mym8.5, INIT

Brief contents

Tables	21
Preface	23
Part 1. Basic debugging	31
The IAR C-SPY Debugger	33
Getting started using C-SPY	43
Executing your application	57
Variables and expressions	81
Breakpoints	107
Memory and registers	141
Part 2. Analyzing your application	179
Trace	181
The application timeline	195
Profiling	225
Code coverage	235
Power debugging	241
Part 3. Advanced debugging	265
Interrupts	267
The advanced cycle counter	291
State storage	299
The sequencer	305
C-SPY macros	311

The C-SPY command line utility—cspybat	373
Part 4. Additional reference information	399
Debugger options	401
Additional information on C-SPY drivers	413
Index	425

Contents

Tables	21
Preface	23
Who should read this guide	23
Required knowledge	23
How to use this guide	23
What this guide contains	24
Part 1. Basic debugging	24
Part 2. Analyzing your application	24
Part 3. Advanced debugging	25
Part 4. Additional reference information	25
Other documentation	25
User and reference guides	26
The online help system	26
Web sites	27
Document conventions	27
Typographic conventions	27
Naming conventions	28
Part I. Basic debugging	31
The IAR C-SPY Debugger	33
Introduction to C-SPY	33
An integrated environment	33
General C-SPY debugger features	34
RTOS awareness	35
Debugger concepts	36
C-SPY and target systems	36
The debugger	37
The target system	37
The application	37
C-SPY debugger systems	38

The ROM-monitor program	38
Third-party debuggers	38
C-SPY plugin modules	38
C-SPY drivers overview	39
Differences between the C-SPY drivers	39
The IAR C-SPY Simulator	40
Supported features	40
The C-SPY hardware debugger drivers	40
Features	41
Communication overview	41
Getting started using C-SPY	43
Setting up C-SPY	43
Setting up for debugging	43
Executing from reset	44
Using a setup macro file	44
Selecting a device description file	44
Loading plugin modules	45
Starting C-SPY	45
Starting a debug session	45
Loading executable files built outside of the IDE	46
Starting a debug session with source files missing	46
Loading multiple debug images	47
Editing in C-SPY windows	47
Adapting for target hardware	48
Modifying a device description file	48
Initializing target hardware before C-SPY starts	49
Using predefined C-SPY macros for device support	50
Reference information on starting C-SPY	50
C-SPY Debugger main window	50
Images window	54
Get Alternative File dialog box	55
Device Information window	56

Executing your application	57
Introduction to application execution	57
Briefly about application execution	57
Source and disassembly mode debugging	57
Single stepping	58
Troubleshooting slow stepping speed	61
Running the application	62
Highlighting	62
Viewing the call stack	63
Terminal input and output	64
Debug logging	64
Reference information on application execution	64
Disassembly window	65
Call Stack window	71
Terminal I/O window	73
Terminal I/O Log File dialog box	74
Debug Log window	75
Log File dialog box	77
Report Assert dialog box	78
Autostep settings dialog box	78
Cores window	79
Variables and expressions	81
Introduction to working with variables and expressions	81
Briefly about working with variables and expressions	81
C-SPY expressions	82
Limitations on variable information	84
Working with variables and expressions	85
Using the windows related to variables and expressions	85
Viewing assembler variables	86
Reference information on working with variables and expressions	87
Auto window	87
Locals window	89

Watch window	91
Live Watch window	93
Statics window	96
Quick Watch window	99
Symbols window	102
Resolve Symbol Ambiguity dialog box	104
Breakpoints	107
Introduction to setting and using breakpoints	107
Reasons for using breakpoints	107
Briefly about setting breakpoints	107
Breakpoint types	108
Breakpoint icons	110
Breakpoints in the C-SPY simulator	110
Breakpoints in the C-SPY FET debugger driver	111
Breakpoint consumers	112
Setting breakpoints	113
Various ways to set a breakpoint	113
Toggling a simple code breakpoint	114
Setting breakpoints using the dialog box	114
Setting a data breakpoint in the Memory window	115
Setting breakpoints using system macros	116
Useful breakpoint hints	117
Reference information on breakpoints	118
Breakpoints window	119
Breakpoint Usage window	121
Code breakpoints dialog box	122
Log breakpoints dialog box	123
Data breakpoints dialog box	125
Data Log breakpoints dialog box	127
Immediate breakpoints dialog box	128
Range breakpoints dialog box	129
Conditional breakpoints dialog box	131
Advanced Trigger breakpoints dialog box	134

Enter Location dialog box	136
Breakpoint combiner dialog box	137
Resolve Source Ambiguity dialog box	138
Memory and registers	141
Introduction to monitoring memory and registers	141
Briefly about monitoring memory and registers	141
C-SPY memory zones	142
Memory configuration for the C-SPY simulator	143
Monitoring memory and registers	144
Defining application-specific register groups	144
Monitoring stack usage	146
Reference information on memory and registers	148
Memory window	149
Memory Save dialog box	153
Memory Restore dialog box	154
Fill dialog box	155
Symbolic Memory window	156
Stack window	159
Registers window	163
Register User Groups Setup window	166
SFR Setup window	168
Edit SFR dialog box	171
Memory Access Setup dialog box	173
Edit Memory Access dialog box	175
Memory Dump dialog box	176
Part 2. Analyzing your application	179
Trace	181
Introduction to using trace	181
Reasons for using trace	181
Briefly about trace	181
Requirements for using trace	182

Collecting and using trace data	182
Getting started with trace	182
Trace data collection using breakpoints	183
Searching in trace data	183
Browsing through trace data	184
Reference information on trace	184
Trace window	184
Function Trace window	188
Trace Start Trigger breakpoint dialog box	189
Trace Stop Trigger breakpoint dialog box	190
Trace Expressions window	191
Find in Trace dialog box	193
Find in Trace window	194
The application timeline	195
Introduction to analyzing your application's timeline	195
Briefly about analyzing the timeline	195
Requirements for timeline support	197
Analyzing your application's timeline	197
Displaying a graph in the Timeline window	198
Navigating in the graphs	198
Analyzing performance using the graph data	199
Getting started using data logging	200
Getting started using data sampling	201
Reference information on application timeline	201
Data Log window	202
Data Log Summary window	205
Data Sample window	208
Data Sample Setup window	209
Sampled Graphs window	211
Timeline window—Call Stack graph	215
Timeline window—Data Log graph	218
Viewing Range dialog box	222

Profiling	225
Introduction to the profiler	225
Reasons for using the profiler	225
Briefly about the profiler	225
Requirements for using the profiler	226
Using the profiler	227
Getting started using the profiler on function level	227
Analyzing the profiling data	228
Getting started using the profiler on instruction level	229
Reference information on the profiler	230
Function Profiler window	230
Code coverage	235
Introduction to code coverage	235
Reasons for using code coverage	235
Briefly about code coverage	235
Requirements and restrictions for using code coverage	235
Using code coverage	236
Getting started using code coverage	236
Reference information on code coverage	236
Code Coverage window	237
Power debugging	241
Introduction to power debugging	241
Reasons for using power debugging	241
Briefly about power debugging	241
Requirements and restrictions for power debugging	243
Optimizing your source code for power consumption	243
Waiting for device status	244
Software delays	244
DMA versus polled I/O	244
Low-power mode diagnostics	244
CPU frequency	245
Detecting mistakenly unattended peripherals	245

Peripheral units in an event-driven system	246
Finding conflicting hardware setups	247
Analog interference	247
Debugging in the power domain	248
Displaying a power profile and analyzing the result	248
Displaying the power profile on a device without EnergyTrace++ ..	249
Detecting unexpected power usage during application execution ...	250
Measuring low power currents	250
Changing the graph resolution	251
Reference information on power debugging	251
Power Log Setup window	252
Power Log window	254
Timeline window—Power graph	257
State Log Setup window	258
State Log window	259
State Log Summary window	261
Timeline window—State Log graph	264

Part 3. Advanced debugging

Interrupts	267
Introduction to interrupts	267
Briefly about the interrupt simulation system	267
Interrupt characteristics	268
Interrupt simulation states	269
C-SPY system macros for interrupt simulation	270
Target-adapting the interrupt simulation system	271
Briefly about interrupt logging	271
Using the interrupt system	271
Simulating a simple interrupt	272
Simulating an interrupt in a multi-task system	273
Getting started using interrupt logging	274
Reference information on interrupts	274
Interrupt Setup dialog box	275

Edit Interrupt dialog box	277
Forced Interrupt window	278
Interrupt Status window	279
Interrupt Log window	281
Interrupt Log Summary window	284
Timeline window—Interrupt Log graph	287
The advanced cycle counter	291
Introduction to the advanced cycle counter	291
Reasons for using the advanced cycle counter	291
Briefly about the advanced cycle counter	291
Requirements for using the advanced cycle counter	291
Using the cycle counter applications	292
Counting all CPU cycles	292
Measuring the DMA load versus the CPU load	292
Profiling a specific part of your application	293
Measuring the Trigger hits	294
Measuring the number of CPU cycles for a task	294
Reference information on the advanced cycle counter	295
Advanced Cycle Counter Control window	295
State storage	299
Introduction to state storage	299
Reasons for using state storage	299
Briefly about state storage	299
Requirements	299
Using state storage	300
Setting up state storage	300
Reference information on state storage	301
State Storage Control window	301
State Storage window	303
The sequencer	305
Introduction to the sequencer	305
Reasons for using the sequencer	305

Briefly about the sequencer	305
Requirements for using the sequencer	306
Using the sequencer	306
Setting up the sequencer (simple setup)	306
Setting up the sequencer (advanced setup)	306
Using the sequencer to locate a problem	307
Reference information on the sequencer	309
Sequencer Control window	309
C-SPY macros	311
Introduction to C-SPY macros	311
Reasons for using C-SPY macros	311
Briefly about using C-SPY macros	312
Briefly about setup macro functions and files	312
Briefly about the macro language	312
Using C-SPY macros	313
Registering C-SPY macros—an overview	314
Executing C-SPY macros—an overview	314
Registering and executing using setup macros and setup files	315
Executing macros using Quick Watch	315
Executing a macro by connecting it to a breakpoint	316
Aborting a C-SPY macro	317
Reference information on the macro language	318
Macro functions	318
Macro variables	318
Macro parameters	319
Macro strings	319
Macro statements	320
Formatted output	321
Reference information on reserved setup macro function names	323
execUserPreload	323
execUserExecutionStarted	324
execUserExecutionStopped	324

execUserSetup	324
execUserPreReset	325
execUserReset	325
execUserExit	325
Reference information on C-SPY system macros	325
__abortLaunch	328
__cancelAllInterrupts	328
__cancelInterrupt	329
__clearBreak	329
__closeFile	329
__delay	330
__disableInterrupts	330
__driverType	330
__enableInterrupts	331
__evaluate	331
__fillMemory8	332
__fillMemory16	333
__fillMemory32	334
__getSelectedCore	335
__isBatchMode	335
__loadImage	335
__memoryRestore	336
__memorySave	337
__messageBoxYesCancel	338
__messageBoxYesNo	339
__openFile	339
__orderInterrupt	340
__popSimulatorInterruptExecutingStack	341
__readFile	342
__readFileByte	343
__readMemory8, __readMemoryByte	343
__readMemory16	344
__readMemory32	344
__registerMacroFile	345

__resetFile	345
__selectCore	345
__setAdvancedTriggerBreak	346
__setCodeBreak	347
__setConditionalBreak	348
__setDataBreak	349
__setDataLogBreak	351
__setLogBreak	352
__setRangeBreak	353
__setSimBreak	354
__setTraceStartBreak	355
__setTraceStopBreak	356
__sourcePosition	357
__strFind	357
__subString	358
__system1	358
__system2	359
__system3	360
__targetDebuggerVersion	360
__toLower	361
__toString	361
__toUpper	362
__unloadImage	362
__wallTime_ms	363
__writeFile	363
__writeFileByte	364
__writeMemory8, __writeMemoryByte	364
__writeMemory16	365
__writeMemory32	365
Graphical environment for macros	366
Macro Registration window	366
Debugger Macros window	368
Macro Quicklaunch window	370

The C-SPY command line utility—cspybat	373
Using C-SPY in batch mode	373
Starting cspybat	373
Output	374
Invocation syntax	374
Summary of C-SPY command line options	375
General cspybat options	375
Options available for all C-SPY drivers	376
Options available for the simulator driver	376
Options available for the C-SPY FET Debugger driver	376
Reference information on C-SPY command line options ...	378
--allow_access_to_BSL	378
--allow_locked_flash_access	378
--application_args	379
--attach_to_running_target	379
--backend	380
--connection	380
--core	380
--code_coverage_file	381
--cycles	381
-d	382
--debug_file	382
--derivative	383
--disable_interrupts	383
--disable_memory_cache	383
--downloadonly	383
--eem	384
--erase_exclude	384
--erase_exclude_all	385
--erase_ip_protected	385
--erase_main	385
--erase_main_and_info	386
--erase_retain_file	386

--erase_retain_target	386
-f	387
--function_profiling	387
--hardware_multiplier	388
--hwmult_type	388
--jtag_speed	389
--leave_target_running	390
--lptx	390
--macro	390
--macro_param	391
--mapu	391
--mspdlogfile	392
--odd_word_check	392
-p	392
--plugin	393
--port	393
--protocol	394
--restore_fram_memory	394
--retain_fram_memory	394
--set_exit_breakpoint	395
--set_getchar_breakpoint	395
--set_putchar_breakpoint	395
--settlingtime	396
--silent	396
--timeout	396
--use_emulated_breakpoints	397
--use_virtual_breakpoints	397
--vccvoltage	397
--verify_all	397

Part 4. Additional reference information	399
Debugger options	401
Setting debugger options	401
Reference information on general debugger options	402
Setup	402
Images	403
Extra Options	404
Plugins	405
Reference information on the C-SPY simulator	406
Setup options for the simulator	406
Reference information on C-SPY hardware debugger driver options	406
Setup for FET Debugger	407
Download	408
Breakpoints	410
Additional information on C-SPY drivers	413
Reference information on C-SPY driver menus	413
<i>C-SPY driver</i>	413
Simulator menu	414
Emulator menu	416
Reference information on the C-SPY simulator	419
Simulated Frequency dialog box	419
Reference information on the C-SPY FET Debugger driver	420
General Clock Control dialog box	420
Extended Clock Control dialog box	421
Resolving problems	421
The device port pins do not work	422
Write failure during load	422
No contact with the target hardware	423
Index	425

Tables

1: Typographic conventions used in this guide	27
2: Naming conventions used in this guide	28
3: Driver differences	39
4: C-SPY assembler symbols expressions	83
5: Handling name conflicts between hardware registers and assembler labels	83
6: C-SPY macros for breakpoints	116
7: Support for timeline information	197
8: Supported graphs in the Timeline window	197
9: C-SPY driver profiling support	227
10: Project options for enabling the profiler	227
11: Project options for enabling code coverage	236
12: Timer interrupt settings	273
13: Cycle Counter 1, combinations of start, stop, and clear reactions	297
14: Sequencer settings - example	308
15: State Storage Control settings—example	308
16: Examples of C-SPY macro variables	319
17: Summary of system macros	325
18: __cancelInterrupt return values	329
19: __disableInterrupts return values	330
20: __driverType return values	331
21: __enableInterrupts return values	331
22: __evaluate return values	332
23: __isBatchMode return values	335
24: __loadImage return values	335
25: __messageBoxYesCancel return values	338
26: __messageBoxYesNo return values	339
27: __openFile return values	340
28: __readFile return values	342
29: __setAdvancedTriggerBreak return values	347
30: __setCodeBreak return values	348
31: __setConditionalBreak return values	349

32: __setDataBreak return values	350
33: __setDataLogBreak return values	351
34: __setLogBreak return values	352
35: __setRangeBreak return values	354
36: __setSimBreak return values	355
37: __setTraceStartBreak return values	355
38: __setTraceStopBreak return values	356
39: __sourcePosition return values	357
40: __unloadImage return values	363
41: cspybat parameters	374
42: Options specific to the C-SPY drivers you are using	401

Preface

Welcome to the *C-SPY® Debugging Guide for MSP430*. The purpose of this guide is to help you fully use the features in the IAR C-SPY® Debugger for debugging your application based on the MSP430 microcontroller.

Who should read this guide

Read this guide if you plan to develop an application using IAR Embedded Workbench and want to get the most out of the features available in C-SPY.

REQUIRED KNOWLEDGE

To use the tools in IAR Embedded Workbench, you should have working knowledge of:

- The architecture and instruction set of the MSP430 microcontroller (refer to the chip manufacturer's documentation)
- The C or C++ programming language
- Application development for embedded systems
- The operating system of your host computer.

For more information about the other development tools incorporated in the IDE, refer to their respective documentation, see *Other documentation*, page 25.

How to use this guide

Each chapter in this guide covers a specific *topic area*. In many chapters, information is typically divided into different sections based on *information types*:

- *Concepts*, which describes the topic and gives overviews of features related to the topic area. Any requirements or restrictions are also listed. Read this section to learn about the topic area.
- *Tasks*, which lists useful tasks related to the topic area. For many of the tasks, you can also find step-by-step descriptions. Read this section for information about required tasks as well as for information about how to perform certain tasks.
- *Reference information*, which gives reference information related to the topic area. Read this section for information about certain GUI components. You can easily access this type of information for a certain component in the IDE by pressing F1.

If you are new to using IAR Embedded Workbench, the tutorials, which you can find in the IAR Information Center, will help you get started using IAR Embedded Workbench.

Finally, we recommend the *Glossary* if you should encounter any unfamiliar terms in the IAR Systems user documentation.

What this guide contains

Below is a brief outline and summary of the chapters in this guide.

Note: Some of the screenshots in this guide are taken from a similar product and not from IAR Embedded Workbench for MSP430.

PART I. BASIC DEBUGGING

- *The IAR C-SPY Debugger* introduces you to the C-SPY debugger and to the concepts that are related to debugging in general and to C-SPY in particular. The chapter also introduces the various C-SPY drivers. The chapter briefly shows the difference in functionality that the various C-SPY drivers provide.
- *Getting started using C-SPY* helps you get started using C-SPY, which includes setting up, starting, and adapting C-SPY for target hardware.
- *Executing your application* describes the conceptual differences between source and disassembly mode debugging, the facilities for executing your application, and finally, how you can handle terminal input and output.
- *Variables and expressions* describes the syntax of the expressions and variables used in C-SPY, as well as the limitations on variable information. The chapter also demonstrates the various methods for monitoring variables and expressions.
- *Breakpoints* describes the breakpoint system and the various ways to set breakpoints.
- *Memory and registers* shows how you can examine memory and registers.

PART 2. ANALYZING YOUR APPLICATION

- *Trace* describes how you can inspect the program flow up to a specific state using trace data.
- *The application timeline* describes the **Timeline** window, and how to use the information in it to analyze your application's behavior.
- *Profiling* describes how the profiler can help you find the functions in your application source code where the most time is spent during execution.
- *Code coverage* describes how the code coverage functionality can help you verify whether all parts of your code have been executed, thus identifying parts which have not been executed.

- *Power debugging* describes techniques for power debugging and how you can use C-SPY to find source code constructions that result in unexpected power consumption.

PART 3. ADVANCED DEBUGGING

- *Interrupts* contains detailed information about the C-SPY interrupt simulation system and how to configure the simulated interrupts to make them reflect the interrupts of your target hardware.
- *The advanced cycle counter* describes the advanced cycle counter for MSP430 devices, and how it can help you to profile your application or to measure how long some tasks take.
- *State storage* describes how the state storage module can help you to examine how your code is executed, and find problems in a specific stage of the execution.
- *The sequencer* describes the sequencer module, a simple state machine that lets you break the execution or trigger the state storage module using a more complex method than a standard breakpoint.
- *C-SPY macros* describes the C-SPY macro system, its features, the purposes of these features, and how to use them.
- *The C-SPY command line utility—cspybat* describes how to use C-SPY in batch mode.

PART 4. ADDITIONAL REFERENCE INFORMATION

- *Debugger options* describes the options you must set before you start the C-SPY debugger.
- *Additional information on C-SPY drivers* describes menus and features provided by the C-SPY drivers not described in any dedicated topics.

Other documentation

User documentation is available as hypertext PDFs and as a context-sensitive online help system in HTML format. You can access the documentation from the Information Center or from the **Help** menu in the IAR Embedded Workbench IDE. The online help system is also available via the F1 key.

USER AND REFERENCE GUIDES

The complete set of IAR Systems development tools is described in a series of guides. Information about:

- System requirements and information about how to install and register the IAR Systems products are available in the *Installation and Licensing Quick Reference Guide* and the *Licensing Guide*.
- Using the IDE for project management and building, is available in the *IDE Project Management and Building Guide for MSP430*.
- Using the IAR C-SPY® Debugger, is available in the *C-SPY® Debugging Guide for MSP430*.
- Programming for the IAR C/C++ Compiler for MSP430, is available in the *IAR C/C++ Compiler User Guide for MSP430*.
- Using the IAR XLINK Linker, the IAR XAR Library Builder, and the IAR XLIB Librarian, is available in the *IAR Linker and Library Tools Reference Guide*.
- Programming for the IAR Assembler for MSP430, is available in the *IAR Assembler Reference Guide for MSP430*.
- Performing a static analysis using C-STAT and the required checks, is available in the *C-STAT® Static Analysis Guide*.
- Developing safety-critical applications using the MISRA C guidelines, is available in the *IAR Embedded Workbench® MISRA C:2004 Reference Guide* or the *IAR Embedded Workbench® MISRA C:1998 Reference Guide*.
- Porting application code and projects created with a previous version of the IAR Embedded Workbench for MSP430, is available in the *IAR Embedded Workbench® Migration Guide*.

Note: Additional documentation might be available depending on your product installation.

THE ONLINE HELP SYSTEM

The context-sensitive online help contains:

- Information about project management, editing, and building in the IDE
- Information about debugging using the IAR C-SPY® Debugger
- Reference information about the menus, windows, and dialog boxes in the IDE
- Compiler reference information
- Keyword reference information for the DLIB library functions. To obtain reference information for a function, select the function name in the editor window and press F1. Note that if you select a function name in the editor window and press F1 while

using the CLIB C standard library, you will get reference information for the DLIB C standard library.

WEB SITES

Recommended web sites:

- The Texas Instruments web site, **www.ti.com**, that contains information and news about the MSP430 microcontrollers.
- The IAR Systems web site, **www.iar.com**, that holds application notes and other product information.
- The web site of the C standardization working group, **www.open-std.org/jtc1/sc22/wg14**.
- The web site of the C++ Standards Committee, **www.open-std.org/jtc1/sc22/wg21**.
- The C++ programming language web site, **isocpp.org**. This web site also has a list of recommended books about C++ programming.
- The C and C++ reference web site, **en.cppreference.com**.

Document conventions

When, in the IAR Systems documentation, we refer to the programming language C, the text also applies to C++, unless otherwise stated.

When referring to a directory in your product installation, for example `430\doc`, the full path to the location is assumed, for example `c:\Program Files\IAR Systems\Embedded Workbench N.n\430\doc`, where the initial digit of the version number reflects the initial digit of the version number of the IAR Embedded Workbench shared components.

TYPOGRAPHIC CONVENTIONS

The IAR Systems documentation set uses the following typographic conventions:

Style	Used for
<code>computer</code>	<ul style="list-style-type: none"> • Source code examples and file paths. • Text on the command line. • Binary, hexadecimal, and octal numbers.
<code>parameter</code>	A placeholder for an actual value used as a parameter, for example <code>filename.h</code> where <code>filename</code> represents the name of the file.

Table 1: Typographic conventions used in this guide





Style	Used for
[option]	An optional part of a stack usage control directive, where [and] are not part of the actual directive, but any [,], {, or } are part of the directive syntax.
{option}	A mandatory part of a stack usage control directive, where { and } are not part of the actual directive, but any [,], {, or } are part of the directive syntax.
[option]	An optional part of a command line option, pragma directive, or library filename.
[a b c]	An optional part of a command line option, pragma directive, or library filename with alternatives.
{a b c}	A mandatory part of a command line option, pragma directive, or library filename with alternatives.
bold	Names of menus, menu commands, buttons, and dialog boxes that appear on the screen.
<i>italic</i>	<ul style="list-style-type: none"> • A cross-reference within this guide or to another guide. • Emphasis.
...	An ellipsis indicates that the previous item can be repeated an arbitrary number of times.
	Identifies instructions specific to the IAR Embedded Workbench® IDE interface.
	Identifies instructions specific to the command line interface.
	Identifies helpful tips and programming hints.
	Identifies warnings.

Table 1: Typographic conventions used in this guide (Continued)

NAMING CONVENTIONS

The following naming conventions are used for the products and tools from IAR Systems®, when referred to in the documentation:

Brand name	Generic term
IAR Embedded Workbench® for MSP430	IAR Embedded Workbench®
IAR Embedded Workbench® IDE for MSP430	the IDE
IAR C-SPY® Debugger for MSP430	C-SPY, the debugger
IAR C-SPY® Simulator	the simulator

Table 2: Naming conventions used in this guide

Brand name	Generic term
IAR C/C++ Compiler™ for MSP430	the compiler
IAR Assembler™ for MSP430	the assembler
IAR XLINK Linker™	XLINK, the linker
IAR XAR Library Builder™	the library builder
IAR XLIB Librarian™	the librarian
IAR CLIB Runtime Environment™	the CLIB runtime environment
IAR DLIB Runtime Environment™	the DLIB runtime environment

Table 2: Naming conventions used in this guide (Continued)

Part I. Basic debugging

This part of the *C-SPY® Debugging Guide for MSP430* includes these chapters:

- The IAR C-SPY Debugger
- Getting started using C-SPY
- Executing your application
- Variables and expressions
- Breakpoints
- Memory and registers

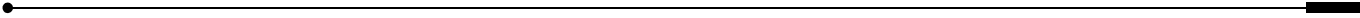
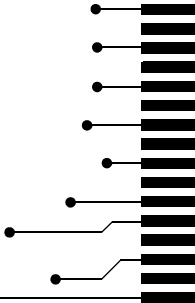

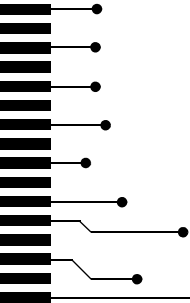

The IAR C-SPY Debugger

- Introduction to C-SPY
- Debugger concepts
- C-SPY drivers overview
- The IAR C-SPY Simulator
- The C-SPY hardware debugger drivers

Introduction to C-SPY

These topics are covered:

- An integrated environment
- General C-SPY debugger features
- RTOS awareness

AN INTEGRATED ENVIRONMENT

C-SPY is a high-level-language debugger for embedded applications. It is designed for use with the IAR Systems compilers and assemblers, and is completely integrated in the IDE, providing development and debugging within the same application. This will give you possibilities such as:

- *Editing while debugging*

During a debug session, you can make corrections directly in the same source code window that is used for controlling the debugging. Changes will be included in the next project rebuild.

- *Setting breakpoints at any point during the development cycle*

You can inspect and modify breakpoint definitions also when the debugger is not running, and breakpoint definitions flow with the text as you edit. Your debug settings, such as watch properties, window layouts, and register groups will be preserved between your debug sessions.

All windows that are open in the IAR Embedded Workbench workspace will stay open when you start the C-SPY Debugger. In addition, a set of C-SPY-specific windows are opened.

GENERAL C-SPY DEBUGGER FEATURES

Because IAR Systems provides an entire toolchain, the output from the compiler and linker can include extensive debug information for the debugger, resulting in good debugging possibilities for you.

C-SPY offers these general features:

- *Source and disassembly level debugging*
C-SPY allows you to switch between source and disassembly debugging as required, for both C or C++ and assembler source code.
- *Single-stepping on a function call level*
Compared to traditional debuggers, where the finest granularity for source level stepping is line by line, C-SPY provides a finer level of control by identifying every statement and function call as a step point. This means that each function call—inside expressions, and function calls that are part of parameter lists to other functions—can be single-stepped. The latter is especially useful when debugging C++ code, where numerous extra function calls are made, for example to object constructors.
- *Code and data breakpoints*
The C-SPY breakpoint system lets you set breakpoints of various kinds in the application being debugged, allowing you to stop at locations of particular interest. For example, you set breakpoints to investigate whether your program logic is correct or to investigate how and when the data changes.
- *Monitoring variables and expressions*
For variables and expressions there is a wide choice of facilities. You can easily monitor values of a specified set of variables and expressions, continuously or on demand. You can also choose to monitor only local variables, static variables, etc.
- *Container awareness*
When you run your application in C-SPY, you can view the elements of library data types such as STL lists and vectors. This gives you a very good overview and debugging opportunities when you work with C++ STL containers.
- *Call stack information*
The compiler generates extensive call stack information. This allows the debugger to show, without any runtime penalty, the complete stack of function calls wherever the program counter is. You can select any function in the call stack, and for each function you get valid information for local variables and available registers.
- *Powerful macro system*
C-SPY includes a powerful internal macro system, to allow you to define complex sets of actions to be performed. C-SPY macros can be used on their own or in

conjunction with complex breakpoints and—if you are using the simulator—the interrupt simulation system to perform a wide variety of tasks.

Additional general C-SPY debugger features

This list shows some additional features:

- Threaded execution keeps the IDE responsive while running the target application
- Automatic stepping
- The source browser provides easy navigation to functions, types, and variables
- Extensive type recognition of variables
- Configurable registers (CPU and peripherals) and memory windows
- Graphical stack view with overflow detection
- Support for code coverage and function level profiling
- The target application can access files on the host PC using file I/O (requires the DLIB library)
- UBROF, Intel-Standard, Intel-extended, Motorola, and TI msp430-txt input formats supported
- Optional terminal I/O emulation

RTOS AWARENESS

C-SPY supports RTOS-aware debugging.

These operating systems are currently supported:

- CMX
- FreeRTOS, OpenRTOS, and SafeRTOS
- Micrium uC/OS-II
- Micrium uC/OS-III
- OSEK
- Segger embOS
- TI-RTOS

RTOS plugin modules can be provided by IAR Systems, and by third-party suppliers. Contact your software distributor or IAR Systems representative, alternatively visit the IAR Systems web site, for information about supported RTOS modules.

A C-SPY RTOS awareness plugin module gives you a high level of control and visibility over an application built on top of an RTOS. It displays RTOS-specific items like task lists, queues, semaphores, mailboxes, and various RTOS system variables. Task-specific breakpoints and task-specific stepping make it easier to debug tasks.

A loaded plugin will add its own menu, set of windows, and buttons when a debug session is started (provided that the RTOS is linked with the application). For information about other RTOS awareness plugin modules, refer to the manufacturer of the plugin module.

Debugger concepts

This section introduces some of the concepts and terms that are related to debugging in general and to C-SPY in particular. This section does not contain specific information related to C-SPY features. Instead, you will find such information in the other chapters of this documentation. The IAR Systems user documentation uses the terms described in this section when referring to these concepts.

These topics are covered:

- C-SPY and target systems
- The debugger
- The target system
- The application
- C-SPY debugger systems
- The ROM-monitor program
- Third-party debuggers
- C-SPY plugin modules

C-SPY AND TARGET SYSTEMS

You can use C-SPY to debug either a software target system or a hardware target system.

This figure gives an overview of C-SPY and possible target systems:

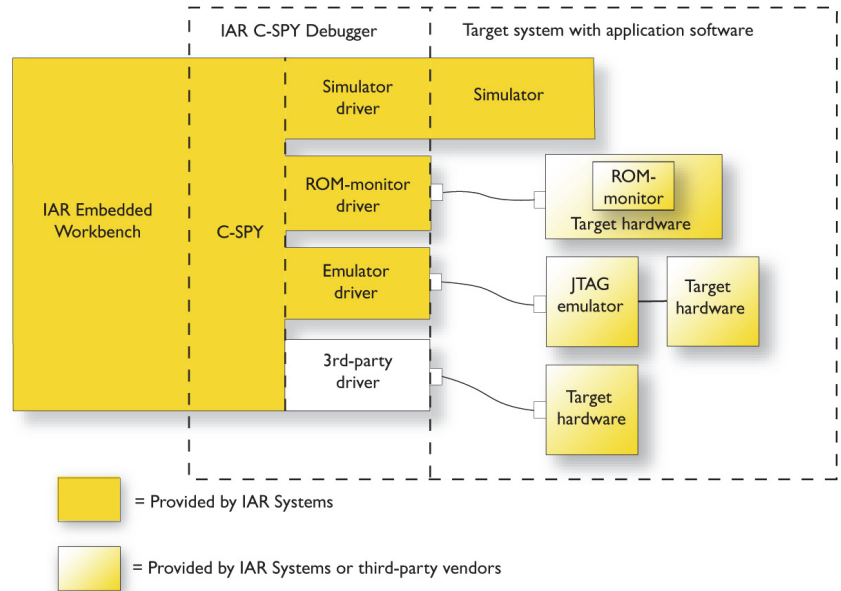

Note: In IAR Embedded Workbench for MSP430, there are no ROM-monitor drivers.

THE DEBUGGER

The debugger, for instance C-SPY, is the program that you use for debugging your applications on a target system.

THE TARGET SYSTEM

The target system is the system on which you execute your application when you are debugging it. The target system can consist of hardware, either an evaluation board or your own hardware design. It can also be completely or partially simulated by software. Each type of target system needs a dedicated C-SPY driver.

THE APPLICATION

A user application is the software you have developed and which you want to debug using C-SPY.

C-SPY DEBUGGER SYSTEMS

C-SPY consists of both a general part which provides a basic set of debugger features, and a target-specific back end. The back end consists of two components: a processor module—one for every microcontroller, which defines the properties of the microcontroller, and a *C-SPY driver*. The C-SPY driver is the part that provides communication with and control of the target system. The driver also provides the user interface—menus, windows, and dialog boxes—to the functions provided by the target system, for instance, special breakpoints.

Typically, there are three main types of C-SPY drivers:

- Simulator driver
- ROM-monitor driver
- Emulator driver

C-SPY is available with a simulator driver, and depending on your product package, optional drivers for hardware debugger systems. For an overview of the available C-SPY drivers and the functionality provided by each driver, see *C-SPY drivers overview*, page 39.

THE ROM-MONITOR PROGRAM

The ROM-monitor program is a piece of firmware that is loaded to non-volatile memory on your target hardware; it runs in parallel with your application. The ROM-monitor communicates with the debugger and provides services needed for debugging the application, for instance stepping and breakpoints.

THIRD-PARTY DEBUGGERS

You can use a third-party debugger together with the IAR Systems toolchain as long as the third-party debugger can read any of the output formats provided by XLINK, such as UBROF, ELF/DWARF, COFF, Intel-extended, Motorola, TI msp430-txt, or any other available format. For information about which format to use with a third-party debugger, see the user documentation supplied with that tool.

C-SPY PLUGIN MODULES

C-SPY is designed as a modular architecture with an open SDK that can be used for implementing additional functionality to the debugger in the form of plugin modules. These modules can be seamlessly integrated in the IDE.

Plugin modules are provided by IAR Systems, or can be supplied by third-party vendors. Examples of such modules are:

- The various C-SPY drivers for debugging using certain debug systems.

- RTOS plugin modules for support for real-time OS aware debugging.
- C-SPYLink that bridges IAR Visual State and IAR Embedded Workbench to make true high-level state machine debugging possible directly in C-SPY, in addition to the normal C level symbolic debugging. For more information, see the documentation provided with IAR Visual State.

For more information about the C-SPY SDK, contact IAR Systems.

C-SPY drivers overview

At the time of writing this guide, the IAR C-SPY Debugger for the MSP430 microcontrollers is available with drivers for these target systems and evaluation boards:

- simulator
- FET Debugger.

DIFFERENCES BETWEEN THE C-SPY DRIVERS

This table summarizes the key differences between the C-SPY drivers:

Feature	Simulator	FET Debugger
Code breakpoints	Unlimited	Yes ¹
Data breakpoints	Yes	—
Execution in real time	—	Yes
Zero memory footprint	Yes	Yes
Simulated interrupts	Yes	—
Real interrupts	—	Yes
Interrupt logging	Yes	—
Data logging	Yes	—
State logging	—	Yes
Live watch	Yes	—
Cycle counter	Yes	Yes ¹
Code coverage	Yes	—
Data coverage	Yes	—
Function/instruction profiling	Yes	— ¹
Trace	Yes	—
Power debugging ¹	—	Yes

Table 3: Driver differences

¹ With specific requirements or restrictions, see the respective chapter in this guide.

The IAR C-SPY Simulator

The C-SPY Simulator simulates the functions of the target processor entirely in software, which means that you can debug the program logic long before any hardware is available. Because no hardware is required, it is also the most cost-effective solution for many applications.

SUPPORTED FEATURES

The C-SPY Simulator supports:

- Instruction-level simulation
- Memory configuration and validation
- Interrupt simulation
- Peripheral simulation (using the C-SPY macro system in conjunction with immediate breakpoints).

Simulating hardware instead of using a hardware debugging system means that some limitations do not apply, but that there are other limitations instead. For example:

- You can set an unlimited number of breakpoints in the simulator.
- When you stop executing your application, time actually stops in the simulator. When you stop application execution on a hardware debugging system, there might still be activities in the system. For example, peripheral units might still be active and reading from or writing to SFR ports.
- Application execution is significantly much slower in a simulator compared to when using a hardware debugging system. However, during a debug session, this might not necessarily be a problem.
- The simulator is not cycle accurate.
- Peripheral simulation is limited in the C-SPY Simulator and therefore the simulator is suitable mostly for debugging code that does not interact too much with peripheral units.

The C-SPY hardware debugger drivers

The C-SPY Flash Emulator Tool Debugger is a JTAG debugger that supports all Texas Instruments' debug probes and boards, and several third-party JTAG debug probes. It provides automatic flash downloading and takes advantage of on-chip debug facilities.

To make the C-SPY FET Debugger work, a communication driver must be installed on the host PC. This driver is automatically installed during the installation of the IAR Embedded Workbench IDE. Because the hardware debugger kernel is built into the microcontroller, no ordinary ROM-monitor program or extra specific hardware is

needed to make the debugging work. You can also use the debugger on your own hardware design.

At the time of writing this guide, the IAR C-SPY Debugger for the MSP430 microcontrollers is available with drivers for these JTAG debug probes supported by the FET debugger driver:

- MSP-FET430UIF
- MSP-FET
- eZFET
- eZ430
- Olimex JTAG interface
- Elprotronic JTAG interface.

FEATURES

In addition to the general features of C-SPY, the FET Debugger driver also provides:

- Execution in real time with full access to the microcontroller
- High-speed communication through a JTAG interface
- Zero memory footprint on the target system
- Hardware code breakpoints
- Built-in flash loader.

Depending on the level of Enhanced Emulation Module (EEM) support, you might also have access to:

- State storage
- Sequencer
- Clock control.

COMMUNICATION OVERVIEW

Most target systems have a debug probe or a debug adapter connected between the host computer and the evaluation board.

The C-SPY FET Debugger driver uses the USB or parallel port to communicate with the FET Interface module. The FET Interface module communicates with the JTAG interface on the hardware.

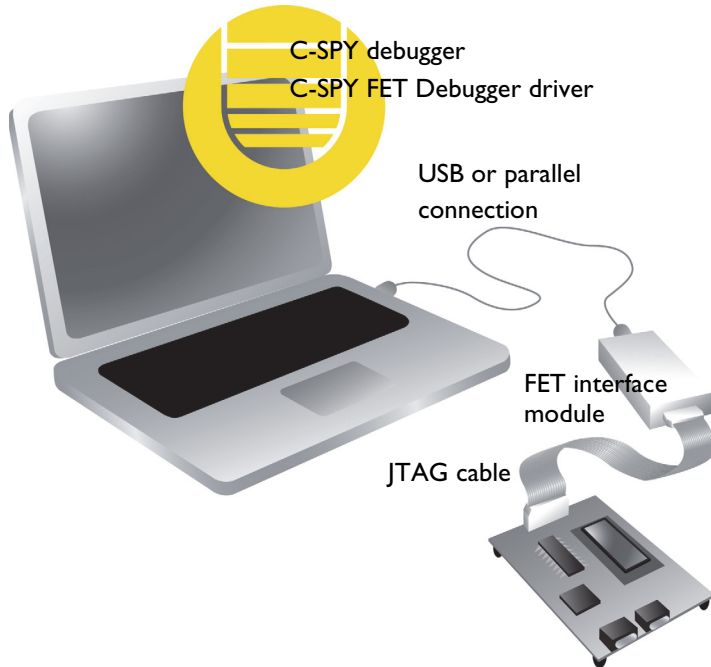

For further information, refer to the documentation supplied with the FET Debugger.

When a debug session is started, your application is automatically downloaded and programmed into flash memory. You can disable this feature, if necessary.

Recommended power-up sequence

For information about the hardware installation, see the documentation supplied with the debug probe from Texas Instruments. The following power-up sequence is recommended to ensure proper communication between the target board, debug probe, and C-SPY:

- 1 Power up the target board, if it is not powered via the debug probe.
- 2 Power up the debug probe, if it is not powered via USB.
- 3 Start the C-SPY debug session.

Getting started using C-SPY

- Setting up C-SPY
- Starting C-SPY
- Adapting for target hardware
- Reference information on starting C-SPY

Setting up C-SPY

These tasks are covered:

- Setting up for debugging
- Executing from reset
- Using a setup macro file
- Selecting a device description file
- Loading plugin modules

SETTING UP FOR DEBUGGING

- 1** Before you start C-SPY, choose **Project>Options>Debugger>Setup** and select the C-SPY driver that matches your debugger system—simulator or hardware debugger system.
- 2** In the **Category** list, select the appropriate C-SPY driver and make your settings. For information about these options, see *Debugger options*, page 401.
- 3** Click **OK**.
- 4** Choose **Tools>Options** to open the **IDE Options** dialog box:
 - Select **Debugger** to configure the debugger behavior
 - Select **Stack** to configure the debugger's tracking of stack usage.

For more information about these options, see the *IDE Project Management and Building Guide for MSP430*. See also *Adapting for target hardware*, page 48.

EXECUTING FROM RESET

The **Run to** option—available on the **Debugger>Setup** page—specifies a location you want C-SPY to run to when you start a debug session as well as after each reset. C-SPY will place a temporary breakpoint at this location and all code up to this point is executed before stopping at the location. Note that this temporary breakpoint is removed when the debugger stops, regardless of how. If you stop the execution before the **Run to** location has been reached, the execution will not stop at that location when you start the execution again.

The default location to run to is the `main` function. Type the name of the location if you want C-SPY to run to a different location. You can specify assembler labels or whatever can be evaluated to such, for instance function names.

If you leave the check box empty, the program counter will contain the regular hardware reset address at each reset. The reset address is set by C-SPY.

USING A SETUP MACRO FILE

A setup macro file is a macro file that you choose to load automatically when C-SPY starts. You can define the setup macro file to perform actions according to your needs, using setup macro functions and system macros. Thus, if you load a setup macro file you can initialize C-SPY to perform actions automatically.

For more information about setup macro files and functions, see *Introduction to C-SPY macros*, page 311.

For an example of how to use a setup macro file, see *Initializing target hardware before C-SPY starts*, page 49.

To register a setup macro file:

- 1 Before you start C-SPY, choose **Project>Options>Debugger>Setup**.
- 2 Select **Use macro file** and type the path and name of your setup macro file, for example `Setup.mac`. If you do not type a filename extension, the extension `mac` is assumed.

SELECTING A DEVICE DESCRIPTION FILE

C-SPY uses device description files to handle device-specific information.

A default device description file is automatically used based on your project settings. If you want to override the default file, you must select your device description file. Device description files from IAR Systems are provided in the `430\config` directory and they have the filename extension `ddf`.

For more information about device description files, see *Adapting for target hardware*, page 48.

To override the default device description file:

- 1 Before you start C-SPY, choose **Project>Options>Debugger>Setup**.
- 2 Select the **Override default** option, and choose a file using the **Device description file** browse button.

Note: You can easily view your device description files that are used for your project. Choose **Project>Open Device Description File** and select the file you want to view.

LOADING PLUGIN MODULES

On the **Plugins** page you can specify C-SPY plugin modules to load and make available during debug sessions. Plugin modules can be provided by IAR Systems, and by third-party suppliers. Contact your software distributor or IAR Systems representative, or visit the IAR Systems web site, for information about available modules.

For more information, see *Plugins*, page 405.

Starting C-SPY

When you have set up the debugger, you are ready to start a debug session.

These tasks are covered:

- Starting a debug session
- Loading executable files built outside of the IDE
- Starting a debug session with source files missing
- Loading multiple debug images
- Editing in C-SPY windows

STARTING A DEBUG SESSION

You can choose to start a debug session with or without loading the current executable file.



To start C-SPY and download the current executable file, click the **Download and Debug** button. Alternatively, choose **Project>Download and Debug**.



To start C-SPY without downloading the current executable file, click the **Debug without Downloading** button. Alternatively, choose **Project>Debug without Downloading**.

LOADING EXECUTABLE FILES BUILT OUTSIDE OF THE IDE

You can also load C-SPY with an application that was built outside the IDE, for example applications built on the command line. To load an externally built executable file and to set build options you must first create a project for it in your workspace.

To create a project for an externally built file:

- 1 Choose **Project>Create New Project**, and specify a project name.
- 2 To add the executable file to the project, choose **Project>Add Files** and make sure to choose **All Files** in the file type drop-down list. Locate the executable file.
- 3 To start the executable file, click the **Download and Debug** button. The project can be reused whenever you rebuild your executable file.

The only project options that are meaningful to set for this kind of project are options in the **General Options** and **Debugger** categories. Make sure to set up the general project options in the same way as when the executable file was built.

STARTING A DEBUG SESSION WITH SOURCE FILES MISSING

Normally, when you use the IAR Embedded Workbench IDE to edit source files, build your project, and start the debug session, all required files are available and the process works as expected.

However, if C-SPY cannot automatically find the source files, for example if the application was built on another computer, the **Get Alternative File** dialog box is displayed:

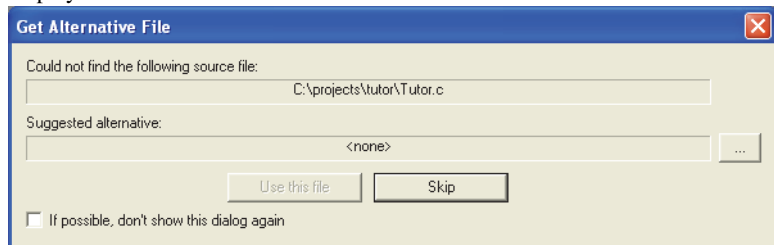

Typically, you can use the dialog box like this:

- The source files are not available: Select **If possible, don't show this dialog again** and then click **Skip**. C-SPY will assume that there is no source file available. The dialog box will not appear again, and the debug session will not try to display the source code.
- Alternative source files are available at another location: Specify an alternative source code file, select **If possible, don't show this dialog again**, and then click **Use this file**. C-SPY will assume that the alternative file should be used. The dialog

box will not appear again, unless a file is needed for which there is no alternative file specified and which cannot be located automatically.

If you restart the IAR Embedded Workbench IDE, the **Get Alternative File** dialog box will be displayed again once even if you have selected **If possible, don't show this dialog again**. This gives you an opportunity to modify your previous settings.

For more information, see *Get Alternative File dialog box*, page 55.

LOADING MULTIPLE DEBUG IMAGES

Normally, a debuggable application consists of a single file that you debug. However, you can also load additional debug files (debug images). This means that the complete program consists of several debug images.

Typically, this is useful if you want to debug your application in combination with a prebuilt ROM image that contains an additional library for some platform-provided features. The ROM image and the application are built using separate projects in the IAR Embedded Workbench IDE and generate separate output files.

If more than one debug image has been loaded, you will have access to the combined debug information for all the loaded debug images. In the **Images** window you can choose whether you want to have access to debug information for a single debug image or for all images.

To load additional debug images at C-SPY startup:

- 1 Choose **Project>Options>Debugger>Images** and specify up to three additional debug images to be loaded. For more information, see *Images*, page 403.
- 2 Start the debug session.

To load additional debug images at a specific moment:

Use the `__loadImage` system macro and execute it using either one of the methods described in *Using C-SPY macros*, page 313.

To display a list of loaded debug images:

Choose **Images** from the **View** menu. The **Images** window is displayed, see *Images window*, page 54.

EDITING IN C-SPY WINDOWS

You can edit the contents of the **Memory**, **Symbolic Memory**, **Registers**, **Register User Groups Setup**, **Auto**, **Watch**, **Locals**, **Statics**, **Live Watch**, and **Quick Watch** windows.

Use these keyboard keys to edit the contents of these windows:

Enter	Makes an item editable and saves the new value.
Esc	Cancels a new value.

In windows where you can edit the **Expression** field and in the **Quick Watch** window, you can specify the number of elements to be displayed in the field by adding a semicolon followed by an integer. For example, to display only the three first elements of an array named `myArray`, or three elements in sequence starting with the element pointed to by a pointer, write:

```
myArray;3
```

To display three elements pointed to by `myPtr`, `myPtr+1`, and `myPtr+2`, write:

```
myPtr;3
```

Optionally, add a comma and another integer that specifies which element to start with. For example, to display elements 10–14, write:

```
myArray;5,10
```

To display `myPtr+10`, `myPtr+11`, `myPtr+12`, `myPtr+13`, and `myPtr+14`, write:

```
myPtr;5,10
```

Note: For pointers, there are no built-in limits on displayed element count, and no validation of the pointer value.

Adapting for target hardware

These tasks are covered:

- Modifying a device description file
- Initializing target hardware before C-SPY starts
- Using predefined C-SPY macros for device support

MODIFYING A DEVICE DESCRIPTION FILE

C-SPY uses device description files provided with the product to handle several of the target-specific adaptations, see *Selecting a device description file*, page 44. Device description files contain device-specific information such as:

- Memory information for device-specific memory zones, see *C-SPY memory zones*, page 142.
- Definitions of memory-mapped peripheral units, device-specific CPU registers, and groups of these.

- Definitions for device-specific interrupts, which makes it possible to simulate these interrupts in the C-SPY simulator, see *Interrupts*, page 267.

Normally, you do not need to modify the device description file. However, if the predefinitions are not sufficient for some reason, you can edit the file. Note, however, that the format of these descriptions might be updated in future upgrades of the product.

Make a copy of the device description file that best suits your needs, and modify it according to the description in the file. Reload the project to make the changes take effect.

For information about how to load a device description file, see *Selecting a device description file*, page 44.

INITIALIZING TARGET HARDWARE BEFORE C-SPY STARTS

You can use C-SPY macros to initialize target hardware before C-SPY starts. For example, if your hardware uses external memory that must be enabled before code can be downloaded to it, C-SPY needs a macro to perform this action before your application can be downloaded.

- 1 Create a new text file and define your macro function.

By using the built-in `execUserPreload` setup macro function, your macro function will be executed directly after the communication with the target system is established but before C-SPY downloads your application.

For example, a macro that enables external SDRAM could look like this:

```
/* Your macro function. */
enableExternalSDRAM()
{
    __message "Enabling external SDRAM\n";
    __writeMemory32(...);
}

/* Setup macro determines time of execution. */
execUserPreload()
{
    enableExternalSDRAM();
}
```

- 2 Save the file with the filename extension `mac`.
- 3 Before you start C-SPY, choose **Project>Options>Debugger** and click the **Setup** tab.
- 4 Select the **Use macro file** option, and choose the macro file you just created.

Your setup macro will now be loaded during the C-SPY startup sequence.

USING PREDEFINED C-SPY MACROS FOR DEVICE SUPPORT

For some MSP430 devices, there are predefined C-SPY macros available for specific device support, typically provided by the chip manufacturer. These macros are useful for performing certain device-specific tasks,

You can easily access and execute these macros using the **Macro Quicklaunch** window.

Reference information on starting C-SPY

Reference information about:

- *C-SPY Debugger main window*, page 50
- *Images window*, page 54
- *Get Alternative File dialog box*, page 55
- *Device Information window*, page 56

See also:

- Tools options for the debugger in the *IDE Project Management and Building Guide for MSP430*.

C-SPY Debugger main window

When you start a debug session, these debugger-specific items appear in the main IAR Embedded Workbench IDE window:

- A dedicated **Debug** menu with commands for executing and debugging your application
- Depending on the C-SPY driver you are using, a driver-specific menu, often referred to as the *Driver menu* in this documentation. Typically, this menu contains menu commands for opening driver-specific windows and dialog boxes.
- A special debug toolbar
- Several windows and dialog boxes specific to C-SPY

The C-SPY main window might look different depending on which components of the product installation you are using.

Menu bar

These menus are available during a debug session:

Debug

Provides commands for executing and debugging the source application. Most of the commands are also available as icon buttons on the debug toolbar.

C-SPY driver menu

Provides commands specific to a C-SPY driver. The driver-specific menu is only available when the driver is used. For information about the driver-specific menu commands, see *Reference information on C-SPY driver menus*, page 413.

Debug menu

The **Debug** menu is available during a debug session. The **Debug** menu provides commands for executing and debugging the source application. Most commands are also available as icon buttons on the debug toolbar.

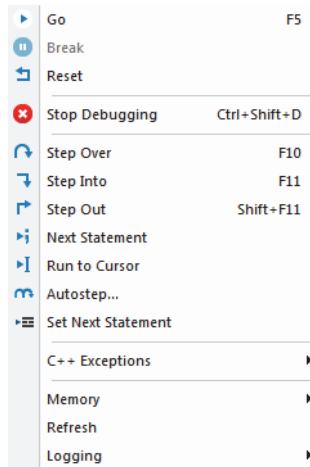

These commands are available:



Go (F5)

Executes from the current statement or instruction until a breakpoint or program exit is reached.



Break

Stops the application execution.



Reset

Resets the target processor. Click the drop-down button to access a menu with additional commands.

Enable Run to 'label', where *label* typically is *main*. Enables and disables the project option **Run to** without exiting the debug session. This menu command is only available if you have selected **Run to** in the **Options** dialog box.

Reset strategies, which contains a list of reset strategies supported by the C-SPY driver you are using. This means that you can choose a different reset strategy than the one used initially without exiting the debug session. Reset strategies are only available if the C-SPY driver you are using supports alternate reset strategies.



Stop Debugging (Ctrl+Shift+D)

Stops the debugging session and returns you to the project manager.



Step Over (F10)

Executes the next statement, function call, or instruction, without entering C or C++ functions or assembler subroutines.



Step Into (F11)

Executes the next statement or instruction, or function call, entering C or C++ functions or assembler subroutines.



Step Out (Shift+F11)

Executes from the current statement up to the statement after the call to the current function.



Next Statement

Executes directly to the next statement without stopping at individual function calls.



Run to Cursor

Executes from the current statement or instruction up to a selected statement or instruction.



Autostep

Displays a dialog box where you can customize and perform autostepping, see *Autostep settings dialog box*, page 78.



Set Next Statement

Moves the program counter directly to where the cursor is, without executing any source code. Note, however, that this creates an anomaly in the program flow and might have unexpected effects.

C++ Exceptions>Break on Throw

This menu command is not supported by your product package.

C++ Exceptions>Break on Uncaught Exception

This menu command is not supported by your product package.

Memory>Save

Displays a dialog box where you can save the contents of a specified memory area to a file, see *Memory Save dialog box*, page 153.

Memory>Restore

Displays a dialog box where you can load the contents of a file in, for example Intel-extended, TI msp430-txt, or Motorola s-record format to a specified memory zone, see *Memory Restore dialog box*, page 154.

Refresh

Refreshes the contents of all debugger windows. Because window updates are automatic, this is needed only in unusual situations, such as when target memory is modified in ways C-SPY cannot detect. It is also useful if code that is displayed in the **Disassembly** window is changed.

Logging>Set Log file

Displays a dialog box where you can choose to log the contents of the **Debug Log** window to a file. You can select the type and the location of the log file. You can choose what you want to log: errors, warnings, system information, user messages, or all of these. See *Log File dialog box*, page 77.

Logging>Set Terminal I/O Log file

Displays a dialog box where you can choose to log simulated target access communication to a file. You can select the destination of the log file. See *Terminal I/O Log File dialog box*, page 74

C-SPY windows

Depending on the C-SPY driver you are using, these windows specific to C-SPY are available during a debug session:

- C-SPY Debugger main window
- Disassembly window
- Memory window
- Symbolic Memory window
- Registers window
- Watch window
- Locals window
- Auto window
- Live Watch window
- Quick Watch window
- Statics window

- Call Stack window
- Trace window
- Function Trace window
- Timeline window, see *Reference information on application timeline*, page 201
- Terminal I/O window
- Code Coverage window
- Function Profiler window
- Images window
- Stack window
- Symbols window

Additional windows are available depending on which C-SPY driver you are using.

Images window

The **Images** window is available from the **View** menu.

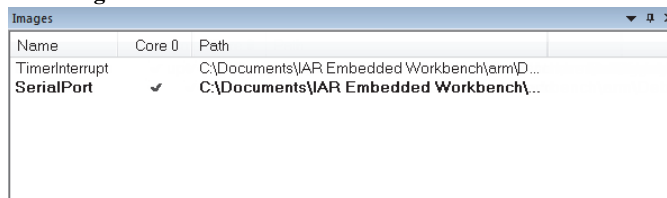

Name	Core 0	Path
TimerInterrupt		C:\Documents\IAR Embedded Workbench\arm\D...
SerialPort	✓	C:\Documents\IAR Embedded Workbench\...

This window lists all currently loaded debug images (debug files).

Normally, a source application consists of a single debug image that you debug. However, you can also load additional images. This means that the complete debuggable unit consists of several debug images. See also *Loading multiple debug images*, page 47.

Requirements

Can be used with all C-SPY debugger drivers and debug probes.

Display area

C-SPY can use debug information from one or more of the loaded debug images simultaneously. Double-click on a row to make C-SPY use debug information from that debug image. The current choices are highlighted.

This area lists the loaded debug images in these columns:

Name

The name of the loaded debug image.

Core *N*

Double-click in this column to toggle using debug information from the debug image when that core is in focus.

Path

The path to the loaded debug image.

Related information

For related information, see:

- *Loading multiple debug images*, page 47
- *Images*, page 403
- *__loadImage*, page 335

Get Alternative File dialog box

The **Get Alternative File** dialog box is displayed if C-SPY cannot automatically find the source files to be loaded, for example if the application was built on another computer.

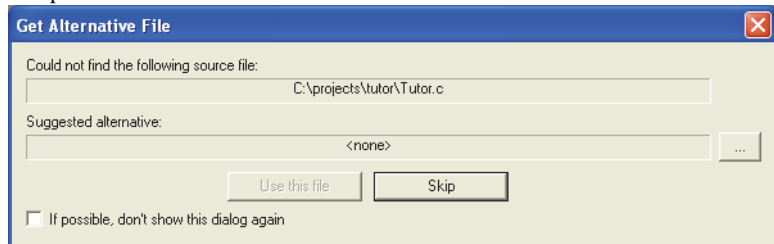

See also *Starting a debug session with source files missing*, page 46.

Could not find the following source file

The missing source file.

Suggested alternative

Specify an alternative file.

Use this file

After you have specified an alternative file, **Use this file** establishes that file as the alias for the requested file. Note that after you have chosen this action, C-SPY will automatically locate other source files if these files reside in a directory structure similar to the first selected alternative file.

The next time you start a debug session, the selected alternative file will be preloaded automatically.

Skip

C-SPY will assume that the source file is not available for this debug session.

If possible, don't show this dialog again

Instead of displaying the dialog box again for a missing source file, C-SPY will use the previously supplied response.

Related information

For related information, see *Starting a debug session with source files missing*, page 46.

Device Information window

The **Device Information** window is available from the **Emulator** menu.

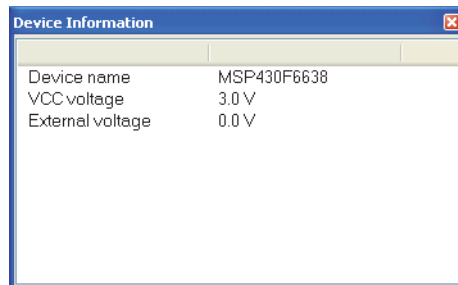

Displays information about the target hardware being used.

Requirements

The C-SPY FET Debugger driver.

Executing your application

- Introduction to application execution
- Reference information on application execution

Introduction to application execution

These topics are covered:

- Briefly about application execution
- Source and disassembly mode debugging
- Single stepping
- Troubleshooting slow stepping speed
- Running the application
- Highlighting
- Viewing the call stack
- Terminal input and output
- Debug logging

BRIEFLY ABOUT APPLICATION EXECUTION

C-SPY allows you to monitor and control the execution of your application. By single-stepping through it, and setting breakpoints, you can examine details about the application execution, for example the values of variables and registers. You can also use the call stack to step back and forth in the function call chain.

The terminal I/O and debug log features let you interact with your application.

You can find commands for execution on the **Debug** menu and on the toolbar.

SOURCE AND DISASSEMBLY MODE DEBUGGING

C-SPY allows you to switch between source mode and disassembly mode debugging as needed.

Source debugging provides the fastest and easiest way of developing your application, without having to worry about how the compiler or assembler has implemented the code. In the editor windows you can execute the application one statement at a time while monitoring the values of variables and data structures.

Disassembly mode debugging lets you focus on the critical sections of your application, and provides you with precise control of the application code. You can open a disassembly window which displays a mnemonic assembler listing of your application based on actual memory contents rather than source code, and lets you execute the application exactly one machine instruction at a time.

Regardless of which mode you are debugging in, you can display registers and memory, and change their contents.

SINGLE STEPPING

C-SPY allows more stepping precision than most other debuggers because it is not line-oriented but statement-oriented. The compiler generates detailed stepping information in the form of *step points* at each statement, and at each function call. That is, source code locations where you might consider whether to execute a step into or a step over command. Because the step points are located not only at each statement but also at each function call, the step functionality allows a finer granularity than just stepping on statements.

There are several factors that can slow down the stepping speed. If you find it too slow, see *Troubleshooting slow stepping speed*, page 61 for some tips.

The step commands

There are four step commands:

- **Step Into**
- **Step Over**
- **Next Statement**
- **Step Out**

Using the **Autostep settings** dialog box, you can automate the single stepping. For more information, see *Autostep settings dialog box*, page 78.

Consider this example and assume that the previous step has taken you to the $f(i)$ function call (highlighted):

```
extern int g(int);
int f(int n)
{
    value = g(n-1) + g(n-2) + g(n-3);
    return value;
}
int main()
{
    ...
    f(i);
    value ++;
}
```



Step Into

While stepping, you typically consider whether to step into a function and continue stepping inside the function or subroutine. The **Step Into** command takes you to the first step point within the subroutine $g(n-1)$:

```
extern int g(int);
int f(int n)
{
    value = g(n-1) + g(n-2) + g(n-3);
    return value;
}
```

The **Step Into** command executes to the next step point in the normal flow of control, regardless of whether it is in the same or another function.



Step Over

The **Step Over** command executes to the next step point in the same function, without stopping inside called functions. The command would take you to the $g(n-2)$ function call, which is not a statement on its own but part of the same statement as $g(n-1)$. Thus, you can skip uninteresting calls which are parts of statements and instead focus on critical parts:

```
extern int g(int);
int f(int n)
{
    value = g(n-1) + g(n-2) + g(n-3);
    return value;
}
```



Next Statement

The **Next Statement** command executes directly to the next statement, in this case `return value`, allowing faster stepping:

```
extern int g(int);
int f(int n)
{
    value = g(n-1) + g(n-2) + g(n-3);
    return value;
}
```



Step Out

When inside the function, you can—if you wish—use the **Step Out** command to step out of it before it reaches the exit. This will take you directly to the statement immediately after the function call:

```
extern int g(int);
int f(int n)
{
    value = g(n-1) + g(n-2) g(n-3);
    return value;
}
int main()
{
    ...
    f(i);
    value ++;
}
```

The possibility of stepping into an individual function that is part of a more complex statement is particularly useful when you use C code containing many nested function calls. It is also very useful for C++, which tends to have many implicit function calls, such as constructors, destructors, assignment operators, and other user-defined operators.

This detailed stepping can in some circumstances be either invaluable or unnecessarily slow. For this reason, you can also step only on statements, which means faster stepping.

Single-stepping and flash memory in the C-SPY FET Debugger

When you use the FET Debugger driver, be aware that single-stepping over instructions that manipulate the flash memory might cause some unexpected side-effects.

Multiple internal machine cycles are required to clear and program the flash memory. When single-stepping over instructions that manipulate the flash memory, control is given back to C-SPY before these operations are complete. Consequently, C-SPY will

update its memory window with erroneous information. A workaround to this behavior is to follow the flash access instruction with a `NOP` instruction, and then step past the `NOP` before reviewing the effects of the flash access instruction.

TROUBLESHOOTING SLOW STEPPING SPEED

If you find that stepping speed is slow, these troubleshooting tips might speed up stepping:

- If you are using a hardware debugger system, keep track of how many hardware breakpoints that are used and make sure some of them are left for stepping.
Stepping in C-SPY is normally performed using breakpoints. When C-SPY performs a step command, a breakpoint is set on the next statement and the application executes until it reaches this breakpoint. If you are using a hardware debugger system, the number of hardware breakpoints—typically used for setting a stepping breakpoint in code that is located in flash/ROM memory—is limited. If you, for example, step into a `C switch` statement, breakpoints are set on each branch; this might consume several hardware breakpoints. If the number of available hardware breakpoints is exceeded, C-SPY switches into single stepping on assembly level, which can be very slow.
For more information, see *Breakpoints in the C-SPY FET debugger driver*, page 111 and *Breakpoint consumers*, page 112.
- Disable trace data collection, using the **Enable/Disable** button in both the **Trace** and the **Function Profiling** windows. Trace data collection might slow down stepping because the collected trace data is processed after each step. Note that it is not sufficient to just close the corresponding windows to disable trace data collection.
- Choose to view only a limited selection of SFR registers. You can choose between two alternatives. Either type `#SFR_name` (where `SFR_name` reflects the name of the SFR you want to monitor) in the **Watch** window, or create your own filter for displaying a limited group of SFRs in the **Registers** window. Displaying many SFR registers might slow down stepping because all registers must be read from the hardware after each step. See *Defining application-specific register groups*, page 144.
- Close the **Memory** and **Symbolic Memory** windows if they are open, because the visible memory must be read after each step and that might slow down stepping.
- Close any window that displays expressions such as **Watch**, **Live Watch**, **Locals**, **Statics** if it is open, because all these windows read memory after each step and that might slow down stepping.
- Close the **Stack** window if it is open. Choose **Tools>Options>Stack** and disable the **Enable graphical stack display and stack usage tracking** option if it is enabled.

- If possible, increase the communication speed between C-SPY and the target board/emulator.

RUNNING THE APPLICATION



Go

The **Go** command continues execution from the current position until a breakpoint or program exit is reached.



Run to Cursor

The **Run to Cursor** command executes to the position in the source code where you have placed the cursor. The **Run to Cursor** command also works in the **Disassembly** window and in the **Call Stack** window.

HIGHLIGHTING

At each stop, C-SPY highlights the corresponding C or C++ source or instruction with a green color, in the editor and the **Disassembly** window respectively. In addition, a green arrow appears in the editor window when you step on C or C++ source level, and in the **Disassembly** window when you step on disassembly level. This is determined by which of the windows is the active window. If none of the windows are active, it is determined by which of the windows was last active.

```
Tutor.c Utilities.c
void init_fib( void )
{
    int i = 45;
    ⇒ root[0] = root[1] = 1;
    for ( i=2 ; i<MAX_FIB ; i++)
    {
```

For simple statements without function calls, the whole statement is typically highlighted. When stopping at a statement with function calls, C-SPY highlights the first call because this illustrates more clearly what **Step Into** and **Step Over** would mean at that time.

Occasionally, you will notice that a statement in the source window is highlighted using a pale variant of the normal highlight color. This happens when the program counter is at an assembler instruction which is part of a source statement but not exactly at a step point. This is often the case when stepping in the **Disassembly** window. Only when the program counter is at the first instruction of the source statement, the ordinary highlight color is used.

Code coverage

From the context menu in the **Code Coverage** window, you can toggle highlight colors and icons in the editor window that show code coverage analysis for the source code, see *Code Coverage window*, page 237.

These are the colors and icons that are used:

- Red highlight color and a red diamond: the code range has not been executed.
- Green highlight color: 100% of the code range has been executed.
- Yellow highlight color and a red diamond: parts of the code range have been executed.

This figure illustrates all three code coverage highlight colors:

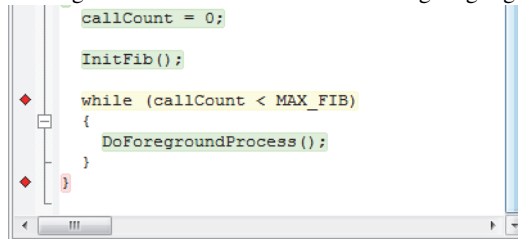

VIEWING THE CALL STACK

The compiler generates extensive call frame information. This allows C-SPY to show, without any runtime penalty, the complete function call chain at any time.



Typically, this is useful for two purposes:

- Determining in what context the current function has been called
- Tracing the origin of incorrect values in variables and in parameters, thus locating the function in the call chain where the problem occurred.

The **Call Stack** window shows a list of function calls, with the current function at the top. When you inspect a function in the call chain, the contents of all affected windows are updated to display the state of that particular call frame. This includes the editor, **Locals**, **Register**, **Watch**, and **Disassembly** windows. A function would normally not make use of all registers, so these registers might have undefined states and be displayed as dashes (---).

In the editor and **Disassembly** windows, a green highlight indicates the topmost, or current, call frame; a yellow highlight is used when inspecting other frames.

For your convenience, it is possible to select a function in the call stack and click the **Run to Cursor** command to execute to that function.

Assembler source code does not automatically contain any call frame information. To see the call chain also for your assembler modules, you can add the appropriate `CFI` assembler directives to the assembler source code. For more information, see the *IAR Assembler Reference Guide for MSP430*.

Note: For highly optimized code, C-SPY might not be able to identify all calls. This means that for highly optimized code, the call stack is not entirely trustworthy.

TERMINAL INPUT AND OUTPUT

Sometimes you might have to debug constructions in your application that use `stdin` and `stdout` without an actual hardware device for input and output. The **Terminal I/O** window lets you enter input to your application, and display output from it. You can also direct terminal I/O to a file, using the **Terminal I/O Log Files** dialog box.



This facility is useful in two different contexts:

- If your application uses `stdin` and `stdout`
- For producing debug trace printouts

For more information, see *Terminal I/O window*, page 73 and *Terminal I/O Log File dialog box*, page 74.

DEBUG LOGGING

The **Debug Log** window displays debugger output, such as diagnostic messages, macro-generated output, and information about trace.



It can sometimes be convenient to log the information to a file where you can easily inspect it, see *Log File dialog box*, page 77. The two main advantages are:

- The file can be opened in another tool, for instance an editor, so you can navigate and search within the file for particularly interesting parts.
- The file provides history about how you have controlled the execution, for instance, which breakpoints that have been triggered etc.

Reference information on application execution

Reference information about:

- *Disassembly window*, page 65
- *Call Stack window*, page 71
- *Terminal I/O window*, page 73
- *Terminal I/O Log File dialog box*, page 74
- *Debug Log window*, page 75

- *Log File dialog box*, page 77
- *Report Assert dialog box*, page 78
- *Autostep settings dialog box*, page 78
- *Cores window*, page 79

See also Terminal I/O options in the *IDE Project Management and Building Guide for MSP430*.

Disassembly window

The C-SPY **Disassembly** window is available from the **View** menu.

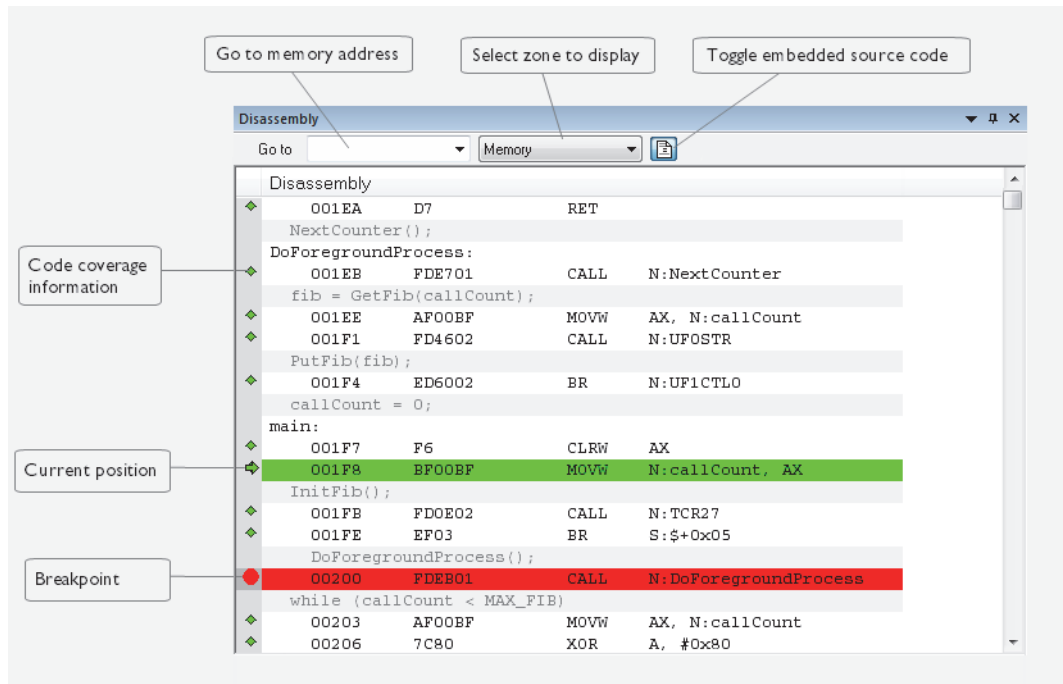

This figure reflects the C-SPY simulator.

This window shows the application being debugged as disassembled application code.

To change the default color of the source code in the Disassembly window:

- 1 Choose **Tools>Options>Debugger**.
- 2 Set the default color using the **Source code color in disassembly window** option.



To view the corresponding assembler code for a function, you can select it in the editor window and drag it to the **Disassembly** window.

See also *Source and disassembly mode debugging*, page 57.

Requirements

Can be used with all C-SPY debugger drivers and debug probes.

Toolbar

The toolbar contains:

Go to

The memory location or symbol you want to view.

Zone

Selects a memory zone, see *C-SPY memory zones*, page 142.

Toggle Mixed-Mode

Toggles between displaying only disassembled code or disassembled code together with the corresponding source code. Source code requires that the corresponding source file has been compiled with debug information

Display area

The display area shows the disassembled application code. This area contains these graphic elements:

Green highlight color	Indicates the current position, that is the next assembler instruction to be executed. To move the cursor to any line in the Disassembly window, click the line. Alternatively, move the cursor using the navigation keys.
Yellow highlight color	Indicates a position other than the current position, such as when navigating between frames in the Call Stack window or between items in the Trace window.
Red dot	Indicates a breakpoint. Double-click in the gray left-side margin of the window to set a breakpoint. For more information, see <i>Breakpoints</i> , page 107.
Green diamond	Code coverage icon—indicates code that has been executed.
Red diamond	Code coverage icon—indicates code that has <i>not</i> been executed.
Red/yellow diamond (red top/yellow bottom)	Code coverage icon—indicates a branch that is <i>never</i> taken.
Red/yellow diamond (red left side/yellow right side)	Code coverage icon—indicates a branch that is <i>always</i> taken.

If instruction profiling has been enabled from the context menu, an extra column in the left-side margin appears with information about how many times each instruction has been executed.

Context menu

This context menu is available:

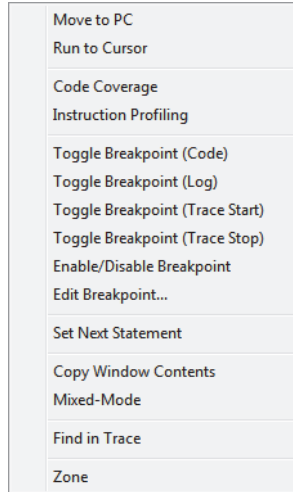

Note: The contents of this menu are dynamic, which means that the commands on the menu might depend on your product package.

These commands are available:

Move to PC

Displays code at the current program counter location.

Run to Cursor

Executes the application from the current position up to the line containing the cursor.

Code Coverage

Displays a submenu that provides commands for controlling code coverage. This command is only enabled if the driver you are using supports it.

Enable	Toggles code coverage on or off.
Show	Toggles the display of code coverage on or off. Code coverage is indicated by a red, green, and red/yellow diamonds in the left margin.
Clear	Clears all code coverage information.

Next Different Coverage >	Moves the insertion point to the next line in the window with a different code coverage status than the selected line.
Previous Different Coverage <	Moves the insertion point to the closest preceding line in the window with a different code coverage status than the selected line.

Instruction Profiling

Displays a submenu that provides commands for controlling instruction profiling. This command is only enabled if the driver you are using supports it.

Enable	Toggles instruction profiling on or off.
Show	Toggles the display of instruction profiling on or off. For each instruction, the left-side margin displays how many times the instruction has been executed.
Clear	Clears all instruction profiling information.

Toggle Breakpoint (Code)

Toggles a code breakpoint. Assembler instructions and any corresponding label at which code breakpoints have been set are highlighted in red. For more information, see *Code breakpoints dialog box*, page 122.

Toggle Breakpoint (Log)

Toggles a log breakpoint for trace printouts. Assembler instructions at which log breakpoints have been set are highlighted in red. For more information, see *Log breakpoints dialog box*, page 123.

Toggle Breakpoint (Trace Start)

Toggles a Trace Start breakpoint. When the breakpoint is triggered, the trace data collection starts. Note that this menu command is only available if the C-SPY driver you are using supports trace. For more information, see *Trace Start Trigger breakpoint dialog box*, page 189.

Toggle Breakpoint (Trace Stop)

Toggles a Trace Stop breakpoint. When the breakpoint is triggered, the trace data collection stops. Note that this menu command is only available if the C-SPY driver you are using supports trace. For more information, see *Trace Stop Trigger breakpoint dialog box*, page 190.

Enable/Disable Breakpoint

Enables and Disables a breakpoint. If there is more than one breakpoint at a specific line, all those breakpoints are affected by the **Enable/Disable** command.

Edit Breakpoint

Displays the breakpoint dialog box to let you edit the currently selected breakpoint. If there is more than one breakpoint on the selected line, a submenu is displayed that lists all available breakpoints on that line.

Set Next Statement

Sets the program counter to the address of the instruction at the insertion point.

Copy Window Contents

Copies the selected contents of the **Disassembly** window to the clipboard.

Mixed-Mode

Toggles between showing only disassembled code or disassembled code together with the corresponding source code. Source code requires that the corresponding source file has been compiled with debug information.

Find in Trace

Searches the contents of the **Trace** window for occurrences of the given location—the position of the insertion point in the source code—and reports the result in the **Find in Trace** window. This menu command requires support for Trace in the C-SPY driver you are using, see *Differences between the C-SPY drivers*, page 39.

Zone

Selects a memory zone, see *C-SPY memory zones*, page 142.

Call Stack window

The **Call Stack** window is available from the **View** menu.

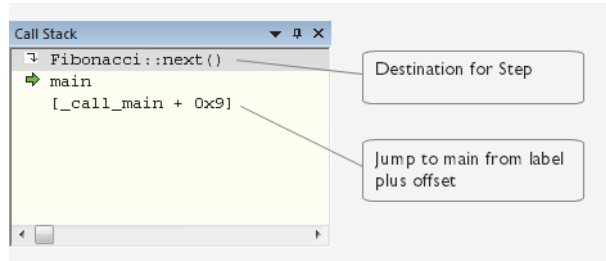

This window displays the C function call stack with the current function at the top. To inspect a function call, double-click it. C-SPY now focuses on that call frame instead.

If the next **Step Into** command would step to a function call, the name of the function is displayed in the gray bar at the top of the window. This is especially useful for implicit function calls, such as C++ constructors, destructors, and operators.

See also *Viewing the call stack*, page 63.

Requirements

Can be used with all C-SPY debugger drivers and debug probes.

Display area

Each entry in the display area is formatted in one of these ways:

<code>function(values)***</code>	A C/C++ function with debug information. Provided that Show Arguments is enabled, <i>values</i> is a list of the current values of the parameters, or empty if the function does not take any parameters. ***, if present, indicates that the function has been inlined by the compiler. For information about function inlining, see the <i>IAR C/C++ Compiler User Guide for MSP430</i> .
<code>[label + offset]</code>	An assembler function, or a C/C++ function without debug information.
<code><exception_frame></code>	An interrupt.

Context menu

This context menu is available:

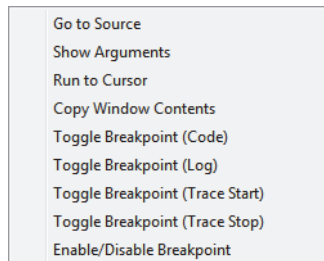

This figure reflects the C-SPY simulator.

These commands are available:

Go to Source

Displays the selected function in the **Disassembly** or editor windows.

Show Arguments

Shows function arguments.

Run to Cursor

Executes until return to the function selected in the call stack.

Copy Window Contents

Copies the contents of the **Call Stack** window and stores them on the clipboard.

Toggle Breakpoint (Code)

Toggles a code breakpoint.

Toggle Breakpoint (Conditional)

Toggles a conditional breakpoint.

Toggle Breakpoint (Advanced Trigger)

Toggles an Advanced Trigger breakpoint.

Toggle Breakpoint (Log)

Toggles a log breakpoint.

Toggle Breakpoint (Trace Start)

Toggles a Trace Start breakpoint. When the breakpoint is triggered, trace data collection starts. Note that this menu command is only available if the C-SPY driver you are using supports it.

Toggle Breakpoint (Trace Stop)

Toggles a Trace Stop breakpoint. When the breakpoint is triggered, trace data collection stops. Note that this menu command is only available if the C-SPY driver you are using supports it.

Enable/Disable Breakpoint

Enables or disables the selected breakpoint

Terminal I/O window

The **Terminal I/O** window is available from the **View** menu.

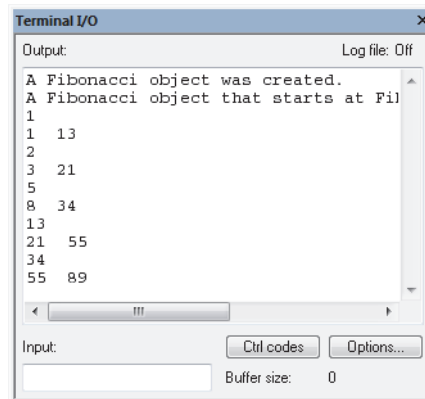

Use this window to enter input to your application, and display output from it.

To use this window, you must:

- I Link your application with the option **With I/O emulation modules**.

C-SPY will then direct `stdin`, `stdout` and `stderr` to this window. If the **Terminal I/O** window is closed, C-SPY will open it automatically when input is required, but not for output.

See also *Terminal input and output*, page 64.

Requirements

Can be used with all C-SPY debugger drivers and debug probes.

Input

Type the text that you want to input to your application.

Ctrl codes

Opens a menu for input of special characters, such as EOF (end of file) and NUL.

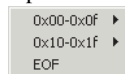
**Options**

Opens the **IDE Options** dialog box where you can set options for terminal I/O. For information about the options available in this dialog box, see *Terminal I/O options in IDE Project Management and Building Guide for MSP430*.

Terminal I/O Log File dialog box

The **Terminal I/O Log File** dialog box is available by choosing **Debug>Logging>Set Terminal I/O Log File**.

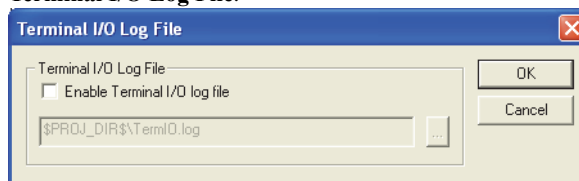

Use this dialog box to select a destination log file for terminal I/O from C-SPY.

See also *Terminal input and output*, page 64.

Requirements

Can be used with all C-SPY debugger drivers and debug probes.

Terminal I/O Log Files

Controls the logging of terminal I/O. To enable logging of terminal I/O to a file, select **Enable Terminal I/O log file** and specify a filename. The default filename extension is `log`. A browse button is available for your convenience.

Debug Log window

The **Debug Log** window is available by choosing **View>Messages>Debug Log**.

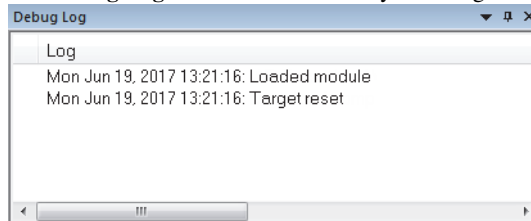

This window displays debugger output, such as diagnostic messages, macro-generated output, and information about trace. This output is only available during a debug session. When opened, this window is, by default, grouped together with the other message windows, see *IDE Project Management and Building Guide for MSP430*.

Double-click any rows in one of the following formats to display the corresponding source code in the editor window:

```
<path> (<row>) :<message>
<path> (<row>, <column>) :<message>
```

See also *Debug logging*, page 64 and *Log File dialog box*, page 77.

Requirements

Can be used with all C-SPY debugger drivers and debug probes.

Context menu

This context menu is available:

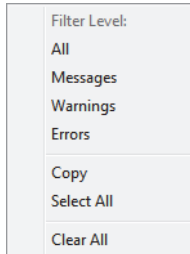

These commands are available:

All

Shows all messages sent by the debugging tools and drivers.

Messages

Shows all C-SPY messages.

Warnings

Shows warnings and errors.

Errors

Shows errors only.

Copy

Copies the contents of the window.

Select All

Selects the contents of the window.

Clear All

Clears the contents of the window.

Log File dialog box

The **Log File** dialog box is available by choosing **Debug>Logging>Set Log File**.

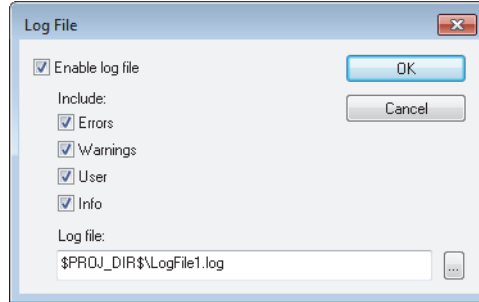

Use this dialog box to log output from C-SPY to a file.

Requirements

Can be used with all C-SPY debugger drivers and debug probes.

Enable log file

Enables or disables logging to the file.

Include

The information printed in the file is, by default, the same as the information listed in the **Debug Log** window. Use the browse button, to override the default file and location of the log file (the default filename extension is `log`). To change the information logged, choose between:

Errors

C-SPY has failed to perform an operation.

Warnings

An error or omission of concern.

User

Messages from C-SPY macros, that is, your messages using the `__message` statement.

Info

Progress information about actions C-SPY has performed.

Report Assert dialog box

The **Report Assert** dialog box appears if you have a call to the `assert` function in your application source code, and the assert condition is false. In this dialog box you can choose how to proceed.

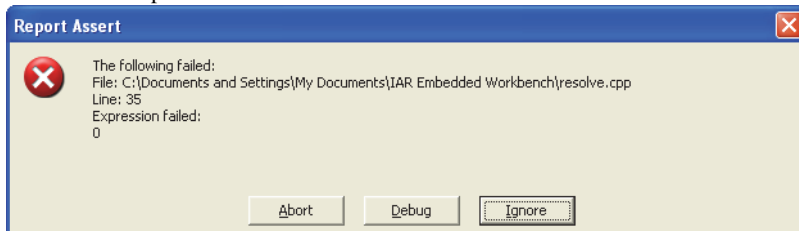

Abort

The application stops executing and the runtime library function `abort`, which is part of your application on the target system, will be called. This means that the application itself terminates its execution.

Debug

C-SPY stops the execution of the application and returns control to you.

Ignore

The assertion is ignored and the application continues to execute.

Autostep settings dialog box

The **Autostep settings** dialog box is available by choosing **Debug>Autostep**.

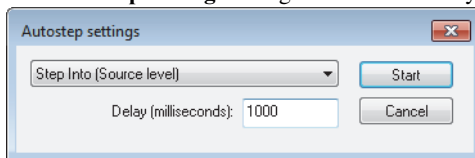

Use this dialog box to customize autostepping.

The drop-down menu lists the available step commands, see *Single stepping*, page 58.

Requirements

Can be used with all C-SPY debugger drivers and debug probes.

Delay (milliseconds)

Specify the delay between each step in milliseconds.

Cores window

The **Cores** window is available from the **View** menu.

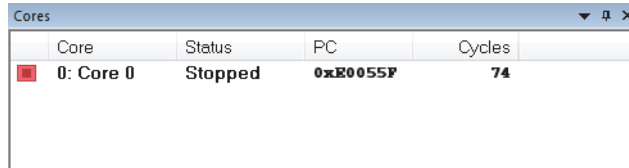

Core	Status	PC	Cycles
0: Core 0	Stopped	0xE055F	74

This window displays information about the executing core, such as its execution state. This information is primarily useful for IAR Embedded Workbench products that support multicore debugging.

Variables and expressions

- Introduction to working with variables and expressions
- Working with variables and expressions
- Reference information on working with variables and expressions

Introduction to working with variables and expressions

This section introduces different methods for looking at variables and introduces some related concepts.

These topics are covered:

- Briefly about working with variables and expressions
- C-SPY expressions
- Limitations on variable information

BRIEFLY ABOUT WORKING WITH VARIABLES AND EXPRESSIONS

There are several methods for looking at variables and calculating their values. These methods are suitable for basic debugging:

- **Tooltip watch**—in the editor window—provides the simplest way of viewing the value of a variable or more complex expressions. Just point at the variable with the mouse pointer. The value is displayed next to the variable.
- The **Auto** window displays a useful selection of variables and expressions in, or near, the current statement. The window is automatically updated when execution stops.
- The **Locals** window displays the local variables, that is, auto variables and function parameters for the active function. The window is automatically updated when execution stops.
- The **Watch** window allows you to monitor the values of C-SPY expressions and variables. The window is automatically updated when execution stops.
- The **Live Watch** window repeatedly samples and displays the values of expressions while your application is executing. Variables in the expressions must be statically located, such as global variables.
- The **Statics** window displays the values of variables with static storage duration. The window is automatically updated when execution stops.

- The **Macro Quicklaunch** window and the **Quick Watch** window give you precise control over when to evaluate an expression.
- The **Symbols** window displays all symbols with a static location, that is, C/C++ functions, assembler labels, and variables with static storage duration, including symbols from the runtime library.

These additional methods for looking at variables are suitable for more advanced analysis:

- The **Data Log** window and the **Data Log Summary** window display logs of accesses to up to four different memory locations you choose by setting data log breakpoints. Data logging can help you locate frequently accessed data. You can then consider whether you should place that data in more efficient memory.
- The **Data Sample** window displays samples for up to four different variables. You can also display the data samples as graphs in the **Sampled Graphs** window. By using data sampling, you will get an indication of the data value over a length of time. Because it is a sampled value, data sampling is best suited for slow-changing data.

For more information about these windows, see *The application timeline*, page 195.

C-SPY EXPRESSIONS

C-SPY expressions can include any type of C expression, except for calls to functions. The following types of symbols can be used in expressions:

- C/C++ symbols
- Assembler symbols (register names and assembler labels)
- C-SPY macro functions
- C-SPY macro variables

Expressions that are built with these types of symbols are called C-SPY expressions and there are several methods for monitoring these in C-SPY. Examples of valid C-SPY expressions are:

```
i + j
i = 42
myVar = cVar
cVar = myVar + 2
#asm_label
#R2
#PC
my_macro_func(19)
```

If you have a static variable with the same name declared in several different functions, use the notation `function::variable` to specify which variable to monitor.

C/C++ symbols

C symbols are symbols that you have defined in the C source code of your application, for instance variables, constants, and functions (functions can be used as symbols but cannot be executed). C symbols can be referenced by their names. Note that C++ symbols might implicitly contain function calls which are not allowed in C-SPY symbols and expressions.

Note: Some attributes available in C/C++, like `volatile`, are not fully supported by C-SPY. For example, this line will not be accepted by C-SPY:

```
sizeof(unsigned char volatile __memattr *)
```

However, this line will be accepted:

```
sizeof(unsigned char __memattr *)
```

Assembler symbols

Assembler symbols can be assembler labels or registers, for example the program counter, the stack pointer, or other CPU registers. If a device description file is used, all memory-mapped peripheral units, such as I/O ports, can also be used as assembler symbols in the same way as the CPU registers. See *Modifying a device description file*, page 48.

Assembler symbols can be used in C-SPY expressions if they are prefixed by #.

Example	What it does
#PC++	Increments the value of the program counter.
myVar = #SP	Assigns the current value of the stack pointer register to your C-SPY variable.
myVar = #label	Sets myVar to the value of an integer at the address of label.
myptr = &#label7	Sets myptr to an int * pointer pointing at label7.

Table 4: C-SPY assembler symbols expressions

In case of a name conflict between a hardware register and an assembler label, hardware registers have a higher precedence. To refer to an assembler label in such a case, you must enclose the label in back quotes ` (ASCII character 0x60). For example:

Example	What it does
#PC	Refers to the program counter.
#'PC'	Refers to the assembler label PC.

Table 5: Handling name conflicts between hardware registers and assembler labels

Which processor-specific symbols are available by default can be seen in the **Registers** window, using the CPU Registers register group. See *Registers window*, page 163.

C-SPY macro functions

Macro functions consist of C-SPY macro variable definitions and macro statements which are executed when the macro is called.

For information about C-SPY macro functions and how to use them, see *Briefly about the macro language*, page 312.

C-SPY macro variables

Macro variables are defined and allocated outside your application, and can be used in a C-SPY expression. In case of a name conflict between a C symbol and a C-SPY macro variable, the C-SPY macro variable will have a higher precedence than the C variable. Assignments to a macro variable assign both its value and type.

For information about C-SPY macro variables and how to use them, see *Reference information on the macro language*, page 318.

Using sizeof

According to standard C, there are two syntactical forms of `sizeof`:

```
sizeof(type)
sizeof expr
```

The former is for types and the latter for expressions.

Note: In C-SPY, do not use parentheses around an expression when you use the `sizeof` operator. For example, use `sizeof x+2` instead of `sizeof (x+2)`.

LIMITATIONS ON VARIABLE INFORMATION

The value of a C variable is valid only on step points, that is, the first instruction of a statement and on function calls. This is indicated in the editor window with a bright green highlight color. In practice, the value of the variable is accessible and correct more often than that.

When the program counter is inside a statement, but not at a step point, the statement or part of the statement is highlighted with a pale variant of the ordinary highlight color.

Effects of optimizations

The compiler is free to optimize the application software as much as possible, as long as the expected behavior remains. The optimization can affect the code so that debugging might be more difficult because it will be less clear how the generated code relates to the source code. Typically, using a high optimization level can affect the code in a way that will not allow you to view a value of a variable as expected.

Consider this example:

```
myFunction()
{
    int i = 42;
    ...
    x = computer(i); /* Here, the value of i is known to C-SPY */
    ...
}
```

From the point where the variable `i` is declared until it is actually used, the compiler does not need to waste stack or register space on it. The compiler can optimize the code, which means that C-SPY will not be able to display the value until it is actually used. If you try to view the value of a variable that is temporarily unavailable, C-SPY will display the text:

```
Unavailable
```

If you need full information about values of variables during your debugging session, you should use the lowest optimization level during compilation, that is, **None**.

Working with variables and expressions

These tasks are covered:

- Using the windows related to variables and expressions
- Viewing assembler variables

See also *Analyzing your application's timeline*, page 197.

USING THE WINDOWS RELATED TO VARIABLES AND EXPRESSIONS

Where applicable, you can add, modify, and remove expressions, and change the display format in the windows related to variables and expressions.

To add a value you can also click in the dotted rectangle and type the expression you want to examine. To modify the value of an expression, click the **Value** field and modify its content. To remove an expression, select it and press the Delete key.



For text that is too wide to fit in a column—in any of these windows, except the **Trace** window—and thus is truncated, just point at the text with the mouse pointer and tooltip information is displayed.

Right-click in any of the windows to access the context menu which contains additional commands. Convenient drag-and-drop between windows is supported, except for in the

Locals window, data logging windows, and the **Quick Watch** window where it is not relevant.

VIEWING ASSEMBLER VARIABLES

An assembler label does not convey any type information at all, which means C-SPY cannot easily display data located at that label without getting extra information. To view data conveniently, C-SPY by default treats all data located at assembler labels as variables of type `int`. However, in the **Watch**, **Live Watch**, and **Quick Watch** windows, you can select a different interpretation to better suit the declaration of the variables.

In this figure, you can see four variables in the **Watch** window and their corresponding declarations in the assembler source file to the left:

Expression	Value	Location	Type
asmvar1	42	0x00000080	int
asmvar2	456	0x00000084	int
asmvar3	55	0x00000088	<8-bit unsigned>
asmvar4	2615	0x0000008C	int

```

asm.s
NAME main

PUBLIC __iar_program_start

SECTION .intvec : CODE (2)
CODE32

__iar_program_start
B main

SECTION .text : CODE (2)

asmvar1: DC32 42
asmvar2: DC32 456
asmvar3: DC8 55
asmvar4: DC8 10

CODE32

main NOE
B main

END

```

Note that `asmvar4` is displayed as an `int`, although the original assembler declaration probably intended for it to be a single byte quantity. From the context menu you can make C-SPY display the variable as, for example, an 8-bit unsigned variable. This has already been specified for the `asmvar3` variable.

Reference information on working with variables and expressions

Reference information about:

- *Auto window*, page 87
- *Locals window*, page 89
- *Watch window*, page 91
- *Live Watch window*, page 93
- *Statics window*, page 96
- *Quick Watch window*, page 99
- *Symbols window*, page 102
- *Resolve Symbol Ambiguity dialog box*, page 104

See also:

- *Reference information on trace*, page 184 for trace-related reference information
- *Macro Quicklaunch window*, page 370

Auto window

The **Auto** window is available from the **View** menu.

Expression	Value	Location	Type
NextCounter	NextCounter (0x40B)		void (__...
fib	1	Memory: 0xFE74	uint32_t
GetFib	GetFib (0x141)		uint32_t(...
callCount	3	Memory: 0xFEFA8	signed int

This window displays a useful selection of variables and expressions in, or near, the current statement. Every time execution in C-SPY stops, the values in the **Auto** window are recalculated. Values that have changed since the last stop are highlighted in red.

See also *Editing in C-SPY windows*, page 47.

Requirements

Can be used with all C-SPY debugger drivers and debug probes.

Context menu

This context menu is available:

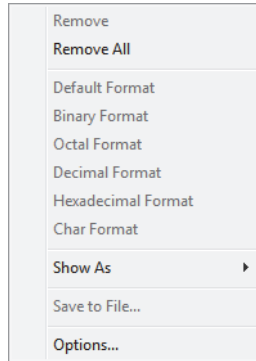

Note: The contents of this menu are dynamic and depend on which features that your combination of software and hardware supports. However, the list of menu commands below is complete and covers all possible commands.

These commands are available:

Remove

Removes the selected expression from the window.

Remove All

Removes all expressions listed in the window.

Default Format

Binary Format

Octal Format

Decimal Format

Hexadecimal Format

Char Format

Changes the display format of expressions. The display format setting affects different types of expressions in different ways. Your selection of display format is saved between debug sessions. These commands are available if a selected line in the window contains a variable.

The display format setting affects different types of expressions in these ways:

Variables	The display setting affects only the selected variable, not other variables.
-----------	--

Array elements	The display setting affects the complete array, that is, the same display format is used for each array element.
----------------	--

Structure fields All elements with the same definition—the same field name and C declaration type—are affected by the display setting.

Show As

Displays a submenu that provides commands for changing the default type interpretation of variables. The commands on this submenu are mainly useful for assembler variables—data at assembler labels—because these are, by default, displayed as integers. For more information, see *Viewing assembler variables*, page 86.

Save to File

Saves content to a file in a tab-separated format.

Options

Displays the **IDE Options** dialog box where you can set various options for C-SPY windows.

Locals window

The **Locals** window is available from the **View** menu.

Variable	Value	Location	Type
i	1244	Memory : 0xPEF72	signed int

This window displays the local variables and parameters for the current function. Every time execution in C-SPY stops, the values in the window are recalculated. Values that have changed since the last stop are highlighted in red.

See also *Editing in C-SPY windows*, page 47.

Requirements

Can be used with all C-SPY debugger drivers and debug probes.

Context menu

This context menu is available:

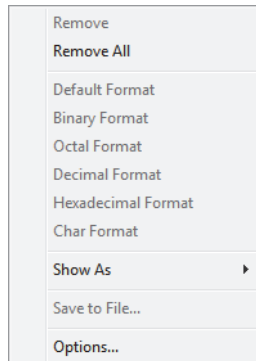

Note: The contents of this menu are dynamic and depend on which features that your combination of software and hardware supports. However, the list of menu commands below is complete and covers all possible commands.

These commands are available:

Remove

Removes the selected expression from the window.

Remove All

Removes all expressions listed in the window.

Default Format

Binary Format

Octal Format

Decimal Format

Hexadecimal Format

Char Format

Changes the display format of expressions. The display format setting affects different types of expressions in different ways. Your selection of display format is saved between debug sessions. These commands are available if a selected line in the window contains a variable.

The display format setting affects different types of expressions in these ways:

Variables The display setting affects only the selected variable, not other variables.

Array elements The display setting affects the complete array, that is, the same display format is used for each array element.

Structure fields All elements with the same definition—the same field name and C declaration type—are affected by the display setting.

Show As

Displays a submenu that provides commands for changing the default type interpretation of variables. The commands on this submenu are mainly useful for assembler variables—data at assembler labels—because these are, by default, displayed as integers. For more information, see *Viewing assembler variables*, page 86.

Save to File

Saves content to a file in a tab-separated format.

Options

Displays the **IDE Options** dialog box where you can set various options for C-SPY windows.

Watch window

The **Watch** window is available from the **View** menu.

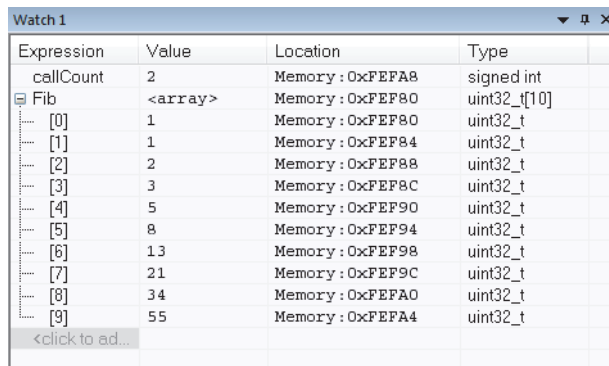

Expression	Value	Location	Type
callCount	2	Memory : 0xFEFA8	signed int
Fib	<array>	Memory : 0xFEFA0	uint32_t[10]
[0]	1	Memory : 0xFEFA0	uint32_t
[1]	1	Memory : 0xFEFA4	uint32_t
[2]	2	Memory : 0xFEFA8	uint32_t
[3]	3	Memory : 0xFEFA8	uint32_t
[4]	5	Memory : 0xFEFA0	uint32_t
[5]	8	Memory : 0xFEFA4	uint32_t
[6]	13	Memory : 0xFEFA8	uint32_t
[7]	21	Memory : 0xFEFA8	uint32_t
[8]	34	Memory : 0xFEFA0	uint32_t
[9]	55	Memory : 0xFEFA4	uint32_t
<click to ad...			

Use this window to monitor the values of C-SPY expressions or variables. You can open up to four instances of this window, where you can view, add, modify, and remove expressions. Tree structures of arrays, structs, and unions are expandable, which means that you can study each item of these.

Every time execution in C-SPY stops, the values in the **Watch** window are recalculated. Values that have changed since the last stop are highlighted in red.



Be aware that expanding very large arrays can cause an out-of-memory crash. To avoid this, expansion is automatically performed in steps of 5000 elements.

See also *Editing in C-SPY windows*, page 47.

Requirements

Can be used with all C-SPY debugger drivers and debug probes.

Context menu

This context menu is available:

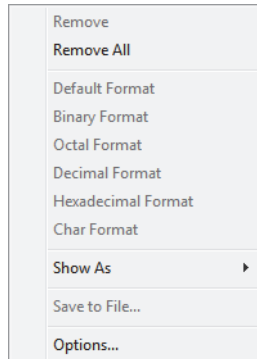

Note: The contents of this menu are dynamic and depend on which features that your combination of software and hardware supports. However, the list of menu commands below is complete and covers all possible commands.

These commands are available:

Remove

Removes the selected expression from the window.

Remove All

Removes all expressions listed in the window.

Default Format

Binary Format

Octal Format

Decimal Format

Hexadecimal Format

Char Format

Changes the display format of expressions. The display format setting affects different types of expressions in different ways. Your selection of display format is saved between debug sessions. These commands are available if a selected line in the window contains a variable.

The display format setting affects different types of expressions in these ways:

Variables	The display setting affects only the selected variable, not other variables.
Array elements	The display setting affects the complete array, that is, the same display format is used for each array element.
Structure fields	All elements with the same definition—the same field name and C declaration type—are affected by the display setting.

Show As

Displays a submenu that provides commands for changing the default type interpretation of variables. The commands on this submenu are mainly useful for assembler variables—data at assembler labels—because these are, by default, displayed as integers. For more information, see *Viewing assembler variables*, page 86.

Save to File

Saves content to a file in a tab-separated format.

Options

Displays the **IDE Options** dialog box where you can set various options for C-SPY windows.

Live Watch window

The **Live Watch** window is available from the **View** menu.

Expression	Value	Location	Type
GetFib	GetFib (0x141)		uint32_t(__ne...
GetFib	GetFib (0x141)	Memory: 0x141	uint32_t(int_f...

This window repeatedly samples and displays the value of expressions while your application is executing. Variables in the expressions must be statically located, such as global variables.

See also *Editing in C-SPY windows*, page 47.

Requirements

The C-SPY simulator.

Display area

This area contains these columns:

Expression

The name of the variable. The base name of the variable is followed by the full name, which includes module, class, or function scope. This column is not editable.

Value

The value of the variable. Values that have changed are highlighted in red.

Dragging text or a variable from another window and dropping it on the **Value** column will assign a new value to the variable in that row.

This column is editable.

Location

The location in memory where this variable is stored.

Type

The data type of the variable.

Context menu

This context menu is available:

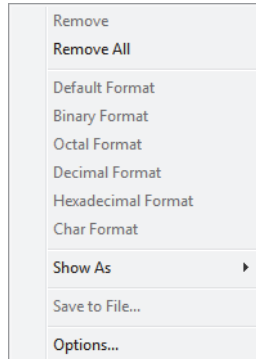

Note: The contents of this menu are dynamic and depend on which features that your combination of software and hardware supports. However, the list of menu commands below is complete and covers all possible commands.

These commands are available:

Remove

Removes the selected expression from the window.

Remove All

Removes all expressions listed in the window.

Default Format**Binary Format****Octal Format****Decimal Format****Hexadecimal Format****Char Format**

Changes the display format of expressions. The display format setting affects different types of expressions in different ways. Your selection of display format is saved between debug sessions. These commands are available if a selected line in the window contains a variable.

The display format setting affects different types of expressions in these ways:

Variables	The display setting affects only the selected variable, not other variables.
Array elements	The display setting affects the complete array, that is, the same display format is used for each array element.
Structure fields	All elements with the same definition—the same field name and C declaration type—are affected by the display setting.

Show As

Displays a submenu that provides commands for changing the default type interpretation of variables. The commands on this submenu are mainly useful for assembler variables—data at assembler labels—because these are, by default, displayed as integers. For more information, see *Viewing assembler variables*, page 86.

Save to File

Saves content to a file in a tab-separated format.

Options

Displays the **IDE Options** dialog box where you can set various options for C-SPY windows.

Statics window

The **Statics** window is available from the **View** menu.

Variable	Value	Location	Type	Module
fibStat <UsingClasses\fibStat>	<class>	Memory : 0xFB140	class Fibonacci	UsingClasses
mCurrent	2	Memory : 0xFB140	uint_fast8_t	
msFib <FibonacciByClass\Fibonacci::msFib>	size=100	Memory : 0xFB134	class vector<uint32_t>	FibonacciByClass
<Raw>	<class>	Memory : 0xFB134	class vector<uint32_t>	
_MyImpl	<class>	Memory : 0xFB134	vector<uint32_t>::Impl	
	<class>	Memory : 0xFB134	class _Vector_value<allocator...	
	<class>	Memory : 0xFB134	class _ClassUtil::_AllocHolder...	
_Myfirst	0xA0E0	Memory : 0xFB134	void __near*	
_Mylast	0xA270	Memory : 0xFB136	void __near*	
_Myend	0xA270	Memory : 0xFB138	void __near*	
<0>	0	Memory : 0xFA0E0	uint32_t	
<1>	0	Memory : 0xFA0E4	uint32_t	

This window displays the values of variables with static storage duration that you have selected. Typically, that is variables with file scope but it can also be static variables in functions and classes. Note that `volatile` declared variables with static storage duration will not be displayed.

Every time execution in C-SPY stops, the values in the **Statics** window are recalculated. Values that have changed since the last stop are highlighted in red.

Click any column header (except for **Value**) to sort on that column.

See also *Editing in C-SPY windows*, page 47.

To select variables to monitor:

- 1 In the window, right-click and choose **Select Statics** from the context menu. The window now lists all variables with static storage duration.
- 2 Either individually select the variables you want to display, or choose one of the **Select** commands from the context menu.
- 3 When you have made your selections, choose **Select Statics** from the context menu to toggle back to normal display mode.

Requirements

Can be used with all C-SPY debugger drivers and debug probes.

Display area

This area contains these columns:

Variable

The name of the variable. The base name of the variable is followed by the full name, which includes module, class, or function scope. This column is not editable.

Value

The value of the variable. Values that have changed are highlighted in red.

Dragging text or a variable from another window and dropping it on the **Value** column will assign a new value to the variable in that row.

This column is editable.

Location

The location in memory where this variable is stored.

Type

The data type of the variable.

Module

The module of the variable.

Context menu

This context menu is available:

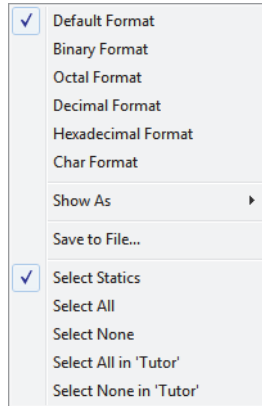

These commands are available:

Default Format

Binary Format

Octal Format

Decimal Format

Hexadecimal Format

Char Format

Changes the display format of expressions. The display format setting affects different types of expressions in different ways. Your selection of display format is saved between debug sessions. These commands are available if a selected line in the window contains a variable.

The display format setting affects different types of expressions in these ways:

Variables	The display setting affects only the selected variable, not other variables.
Array elements	The display setting affects the complete array, that is, the same display format is used for each array element.
Structure fields	All elements with the same definition—the same field name and C declaration type—are affected by the display setting.

Show As

Displays a submenu that provides commands for changing the default type interpretation of variables. The commands on this submenu are mainly useful for assembler variables—data at assembler labels—because these are, by default, displayed as integers. For more information, see *Viewing assembler variables*, page 86.

Save to File

Saves the content of the **Statics** window to a log file.

Select Statics

Selects all variables with static storage duration; this command also enables all **Select** commands below. Select the variables you want to monitor. When you have made your selections, select this menu command again to toggle back to normal display mode.

Select All

Selects all variables.

Select None

Deselects all variables.

Select All in *module*

Selects all variables in the selected module.

Select None in *module*

Deselects all variables in the selected module.

Quick Watch window

The **Quick Watch** window is available from the **View** menu and from the context menu in the editor window.

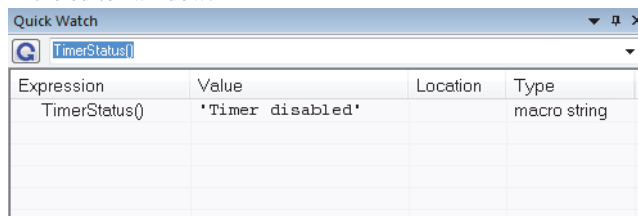

Use this window to watch the value of a variable or expression and evaluate expressions at a specific point in time.

In contrast to the **Watch** window, the **Quick Watch** window gives you precise control over when to evaluate the expression. For single variables this might not be necessary,

but for expressions with possible side effects, such as assignments and C-SPY macro functions, it allows you to perform evaluations under controlled conditions.

See also *Editing in C-SPY windows*, page 47.

To evaluate an expression:

1 In the editor window, right-click on the expression you want to examine and choose **Quick Watch** from the context menu that appears.

2 The expression will automatically appear in the **Quick Watch** window.

Alternatively:

3 In the **Quick Watch** window, type the expression you want to examine in the **Expressions** text box.



4 Click the **Recalculate** button to calculate the value of the expression.

For an example, see *Using C-SPY macros*, page 313.

Requirements

Can be used with all C-SPY debugger drivers and debug probes.

Context menu

This context menu is available:

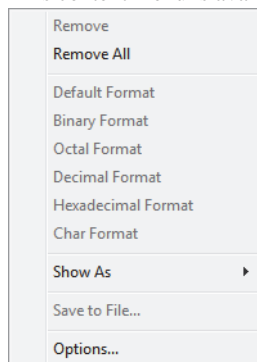

Note: The contents of this menu are dynamic and depend on which features that your combination of software and hardware supports. However, the list of menu commands below is complete and covers all possible commands.

These commands are available:

Remove

Removes the selected expression from the window.

Remove All

Removes all expressions listed in the window.

Default Format**Binary Format****Octal Format****Decimal Format****Hexadecimal Format****Char Format**

Changes the display format of expressions. The display format setting affects different types of expressions in different ways. Your selection of display format is saved between debug sessions. These commands are available if a selected line in the window contains a variable.

The display format setting affects different types of expressions in these ways:

Variables	The display setting affects only the selected variable, not other variables.
Array elements	The display setting affects the complete array, that is, the same display format is used for each array element.
Structure fields	All elements with the same definition—the same field name and C declaration type—are affected by the display setting.

Show As

Displays a submenu that provides commands for changing the default type interpretation of variables. The commands on this submenu are mainly useful for assembler variables—data at assembler labels—because these are, by default, displayed as integers. For more information, see *Viewing assembler variables*, page 86.

Save to File

Saves content to a file in a tab-separated format.

Options

Displays the **IDE Options** dialog box where you can set various options for C-SPY windows.

Symbols window

The **Symbols** window is available from the **View** menu.

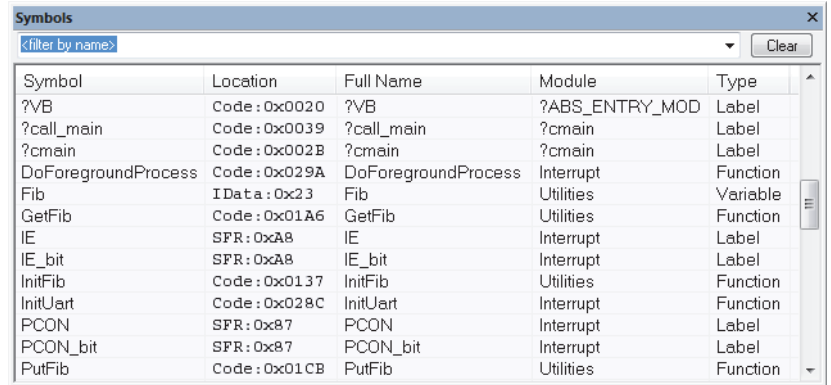

Symbol	Location	Full Name	Module	Type
?VB	Code : 0x0020	?VB	?ABS_ENTRY_MOD	Label
?call_main	Code : 0x0039	?call_main	?cmain	Label
?cmain	Code : 0x002B	?cmain	?cmain	Label
DoForegroundProcess	Code : 0x029A	DoForegroundProcess	Interrupt	Function
Fib	IData : 0x23	Fib	Utilities	Variable
GetFib	Code : 0x01A6	GetFib	Utilities	Function
IE	SFR : 0xA8	IE	Interrupt	Label
IE_bit	SFR : 0xA8	IE_bit	Interrupt	Label
InitFib	Code : 0x0137	InitFib	Utilities	Function
InitUart	Code : 0x028C	InitUart	Interrupt	Function
PCON	SFR : 0x87	PCON	Interrupt	Label
PCON_bit	SFR : 0x87	PCON_bit	Interrupt	Label
PutFib	Code : 0x01CB	PutFib	Utilities	Function

This window displays all symbols with a static location, that is, C/C++ functions, assembler labels, and variables with static storage duration, including symbols from the runtime library.

You can drag the contents of cells in the **Symbol**, **Location**, and **Full Name** columns and drop in some other windows in the IDE.

Requirements

Can be used with all C-SPY debugger drivers and debug probes.

Toolbar

The toolbar contains:

<filter by name>

Type the first characters of the symbol names that you want to find, and press Enter. All symbols (of the types you have selected on the context menu) whose name starts with these characters will be displayed. If you have chosen not to display some types of symbols, the window will list how many of those that were found but are not displayed.

Use the drop-down list to use old search strings. The search box has a history depth of eight search entries.

Clear

Cancels the effects of the search filter and restores all symbols in the window.

Display area

This area contains these columns:

Symbol

The symbol name.

Location

The memory address.

Full name

The symbol name; often the same as the contents of the **Symbol** column but differs for example for C++ member functions.

Module

The program module where the symbol is defined.

Type

The symbol type, whether it is a function, label, or variable.

Click the column headers to sort the list by symbol name, location, full name, module, or type.

Context menu

This context menu is available:

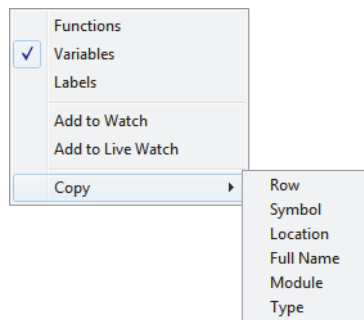

These commands are available:

Functions

Toggles the display of function symbols on or off in the list.

Variables

Toggles the display of variables on or off in the list.

Labels

Toggles the display of labels on or off in the list.

Add to Watch

Adds the selected symbol to the **Watch** window.

Add to Live Watch

Adds the selected symbol to the **Live Watch** window.

Copy

Copies the contents of the cells on the selected line.

Row Copies all contents of the selected line

Symbol Copies the contents of the **Symbol** cell on the selected line

Location Copies the contents of the **Location** cell on the selected line

Full Name Copies the contents of the **Full Name** cell on the selected line

Module Copies the contents of the **Module** cell on the selected line

Type Copies the contents of the **Type** cell on the selected line

Resolve Symbol Ambiguity dialog box

The **Resolve Symbol Ambiguity** dialog box appears, for example, when you specify a symbol in the **Disassembly** window to go to, and there are several instances of the same symbol due to templates or function overloading.

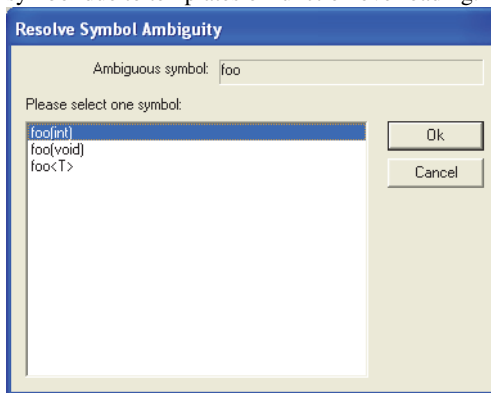

Requirements

Can be used with all C-SPY debugger drivers and debug probes.

Ambiguous symbol

Indicates which symbol that is ambiguous.

Please select one symbol

A list of possible matches for the ambiguous symbol. Select the one you want to use.

Breakpoints

- Introduction to setting and using breakpoints
- Setting breakpoints
- Reference information on breakpoints

Introduction to setting and using breakpoints

These topics are covered:

- Reasons for using breakpoints
- Briefly about setting breakpoints
- Breakpoint types
- Breakpoint icons
- Breakpoints in the C-SPY simulator
- Breakpoints in the C-SPY FET debugger driver
- Breakpoint consumers

REASONS FOR USING BREAKPOINTS

C-SPY® lets you set various types of breakpoints in the application you are debugging, allowing you to stop at locations of particular interest. You can set a breakpoint at a *code* location to investigate whether your program logic is correct, or to get trace printouts. In addition to code breakpoints, and depending on what C-SPY driver you are using, additional breakpoint types might be available. For example, you might be able to set a *data* breakpoint, to investigate how and when the data changes.

You can let the execution stop under certain *conditions*, which you specify. You can also let the breakpoint trigger a *side effect*, for instance executing a C-SPY macro function, by transparently stopping the execution and then resuming. The macro function can be defined to perform a wide variety of actions, for instance, simulating hardware behavior.

All these possibilities provide you with a flexible tool for investigating the status of your application.

BRIEFLY ABOUT SETTING BREAKPOINTS

You can set breakpoints in many various ways, allowing for different levels of interaction, precision, timing, and automation. All the breakpoints you define will

appear in the **Breakpoints** window. From this window you can conveniently view all breakpoints, enable and disable breakpoints, and open a dialog box for defining new breakpoints. The **Breakpoint Usage** window also lists all internally used breakpoints, see *Breakpoint consumers*, page 112.

Breakpoints are set with a higher precision than single lines, using the same mechanism as when stepping. For more information about the precision, see *Single stepping*, page 58.

You can set breakpoints while you edit your code even if no debug session is active. The breakpoints will then be validated when the debug session starts. Breakpoints are preserved between debug sessions.

Note: For most hardware debugger systems it is only possible to set breakpoints when the application is not executing.

BREAKPOINT TYPES

Depending on the C-SPY driver you are using, C-SPY supports different types of breakpoints.

Code breakpoints

Code breakpoints are used for code locations to investigate whether your program logic is correct or to get trace printouts. Code breakpoints are triggered when an instruction is fetched from the specified location. If you have set the breakpoint on a specific machine instruction, the breakpoint will be triggered and the execution will stop, before the instruction is executed.

For the C-SPY FET Debugger driver, a code breakpoint can be either a hardware or a software breakpoint.

Log breakpoints

Log breakpoints provide a convenient way to add trace printouts without having to add any code to your application source code. Log breakpoints are triggered when an instruction is fetched from the specified location. If you have set the breakpoint on a specific machine instruction, the breakpoint will be triggered and the execution will temporarily stop and print the specified message in the C-SPY **Debug Log** window.

Trace Start/Stop Trigger breakpoints

Trace Start Trigger and Trace Stop Trigger breakpoints start and stop trace data collection—a convenient way to analyze instructions between two execution points.

Data breakpoints

Data breakpoints are primarily useful for variables that have a fixed address in memory. If you set a breakpoint on an accessible local variable, the breakpoint is set on the corresponding memory location. The validity of this location is only guaranteed for small parts of the code. Data breakpoints are triggered when data is accessed at the specified location. The execution will usually stop directly after the instruction that accessed the data has been executed.

Data Log breakpoints

Data log breakpoints are triggered when a specified memory address is accessed. A log entry is written in the **Data Log** window for each access. Data logs can also be displayed on the Data Log graph in the **Timeline** window, if that window is enabled.

You can set data log breakpoints using the **Breakpoints** window, the **Memory** window, and the editor window.

Using a single instruction, the microcontroller can only access values that are two bytes or less. If you specify a data log breakpoint on a memory location that cannot be accessed by one instruction, for example a `double` or a too large area in the **Memory** window, the result might not be what you intended.

Immediate breakpoints

The C-SPY Simulator lets you set *immediate* breakpoints, which will halt instruction execution only temporarily. This allows a C-SPY macro function to be called when the simulated processor is about to read data from a location or immediately after it has written data. Instruction execution will resume after the action.

This type of breakpoint is useful for simulating memory-mapped devices of various kinds (for instance serial ports and timers). When the simulated processor reads from a memory-mapped location, a C-SPY macro function can intervene and supply appropriate data. Conversely, when the simulated processor writes to a memory-mapped location, a C-SPY macro function can act on the value that was written.

Range breakpoints

Range breakpoints can be set on a data or an address range, and the action can be specified to occur on an access inside or outside the specified range. These breakpoints are only available if you are using a device that supports the Enhanced Emulation Module at the required level.

Advanced trigger breakpoints

Advanced trigger breakpoints can be set with various operators on the address bus, the data bus, or on a register, to be triggered by a certain kind of access. These breakpoints

are only available if you are using a device that supports the Enhanced Emulation Module at the required level.

Conditional breakpoints

Conditional breakpoints can be set with various operators on the address bus, the data bus, or on a register, to be triggered by a certain kind of access. You can also specify a conditional value. These breakpoints are only available if you are using a device that supports the Enhanced Emulation Module at the required level.

BREAKPOINT ICONS

A breakpoint is marked with an icon in the left margin of the editor window, and the icon varies with the type of breakpoint:

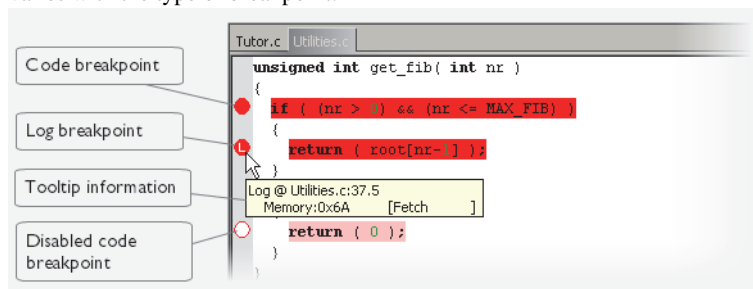

If the breakpoint icon does not appear, make sure the option **Show bookmarks** is selected, see Editor options in the *IDE Project Management and Building Guide for MSP430*.



Just point at the breakpoint icon with the mouse pointer to get detailed tooltip information about all breakpoints set on the same location. The first row gives user breakpoint information, the following rows describe the physical breakpoints used for implementing the user breakpoint. The latter information can also be seen in the **Breakpoint Usage** window.

Note: The breakpoint icons might look different for the C-SPY driver you are using.

BREAKPOINTS IN THE C-SPY SIMULATOR

The C-SPY simulator supports all breakpoint types. The number of breakpoints is unlimited.

BREAKPOINTS IN THE C-SPY FET DEBUGGER DRIVER

Using the C-SPY drivers for the C-SPY FET debugger, you can set *code* breakpoints. If you are using a device that supports the *Enhanced Emulation Module* at the required level, you also have access to an extended breakpoint system with support for:

- breakpoints on addresses, data, and registers
- defining which type of access that should trigger the breakpoint: read, write, or fetch
- setting conditional breakpoints
- triggering different actions: stopping the execution, or starting the state storage module
- emulated breakpoints.

The Enhanced Emulation Module (at the required level) also gives you access to the sequencer module which is a state machine that uses breakpoints for triggering new states.

Hardware breakpoints

To set breakpoints, the C-SPY FET Debugger uses the hardware breakpoints available on the device. The number of hardware breakpoints is limited, and when all hardware breakpoints have been used, C-SPY can use software breakpoints.

For information about the number of available hardware breakpoints for each device, see the release notes or the hardware documentation.

Software breakpoints

There are two types of software breakpoints: *virtual breakpoints* and *emulated breakpoints*. For information about how to specify which type to use, see *Breakpoints*, page 410.

When virtual breakpoints are used, C-SPY is forced into single-step mode after all hardware breakpoints have been used. However, if your device supports the Enhanced Emulation Module at the required level, you can use emulated breakpoints for access to an unlimited number of breakpoints.

When emulated breakpoints are used, the instruction where the breakpoint is set will be replaced by a special instruction that the debugger recognizes. When the debugger encounters such an instruction, it stops. This mechanism uses one hardware breakpoint to emulate an unlimited number of breakpoints.

To prevent the debugger from executing in single-step mode if you do not use emulated software breakpoints, you can disable the use of virtual breakpoints and—in the CLIB runtime environment—fine-tune the use of breakpoint consumers. This will increase the

performance of the debugger, but you will only have access to the available number of hardware breakpoints. For information about the breakpoint consumers of the debugger system, see *Breakpoint consumers*, page 112.

BREAKPOINT CONSUMERS

A debugger system includes several consumers of breakpoints.

User breakpoints

The breakpoints you define in the breakpoint dialog box or by toggling breakpoints in the editor window often consume one physical breakpoint each, but this can vary greatly. Some user breakpoints consume several physical breakpoints and conversely, several user breakpoints can share one physical breakpoint. User breakpoints are displayed in the same way both in the **Breakpoint Usage** window and in the **Breakpoints** window, for example **Data @[R] callCount**.

C-SPY itself

C-SPY itself also consumes breakpoints. C-SPY will set a breakpoint if:

- The debugger option **Run to** has been selected, and any step command is used. These are temporary breakpoints which are only set during a debug session. This means that they are not visible in the **Breakpoints** window.
- The linker option **With I/O emulation modules** has been selected.
 - In the DLIB runtime environment, C-SPY will set a system breakpoint on the `__DebugBreak` label.
 - In the CLIB runtime environment, C-SPY will set a breakpoint if:
 - the library functions `putchar` and `getchar` are used (low-level routines used by functions like `printf` and `scanf`)
 - the application has an `exit` label.

You can disable the setting of system breakpoints on the `putchar` and `getchar` functions and on the `exit` label, see *Breakpoints*, page 410.

When the **Run to** option is selected and all hardware breakpoints have already been used, a virtual breakpoint will be set even if you have deselected the **Use virtual breakpoints** option. When you start the debugger under these conditions, C-SPY will prompt you to choose whether you want to execute in single-step mode or stop at the first instruction.

These types of breakpoint consumers are displayed in the **Breakpoint Usage** window, for example, **C-SPY Terminal I/O & libsupport module**.

C-SPY plugin modules

For example, modules for real-time operating systems can consume additional breakpoints. Specifically, by default, the **Stack** window consumes one physical breakpoint.

To disable the breakpoint used by the Stack window:

- 1 Choose **Tools>Options>Stack**.
- 2 Deselect the **Stack pointer(s) not valid until program reaches: *label*** option.

To disable the **Stack** window entirely, choose **Tools>Options>Stack** and make sure all options are deselected.

Setting breakpoints

These tasks are covered:

- Various ways to set a breakpoint
- Toggling a simple code breakpoint
- Setting breakpoints using the dialog box
- Setting a data breakpoint in the Memory window
- Setting breakpoints using system macros
- Useful breakpoint hints

VARIOUS WAYS TO SET A BREAKPOINT

You can set a breakpoint in various ways:

- Toggling a simple code breakpoint.
- Using the **New Breakpoints** dialog box and the **Edit Breakpoints** dialog box available from the context menus in the editor window, **Breakpoints** window, and in the **Disassembly** window. The dialog boxes give you access to all breakpoint options.
- Setting a data breakpoint on a memory area directly in the **Memory** window.
- Using predefined system macros for setting breakpoints, which allows automation.

The different methods offer different levels of simplicity, complexity, and automation.

TOGGLING A SIMPLE CODE BREAKPOINT

Toggling a code breakpoint is a quick method of setting a breakpoint. The following methods are available both in the editor window and in the **Disassembly** window:



- Click in the gray left-side margin of the window
- Place the insertion point in the C source statement or assembler instruction where you want the breakpoint, and click the **Toggle Breakpoint** button in the toolbar
- Choose **Edit>Toggle Breakpoint**
- Right-click and choose **Toggle Breakpoint** from the context menu.

SETTING BREAKPOINTS USING THE DIALOG BOX

The advantage of using a breakpoint dialog box is that it provides you with a graphical interface where you can interactively fine-tune the characteristics of the breakpoints. You can set the options and quickly test whether the breakpoint works according to your intentions.

All breakpoints you define using a breakpoint dialog box are preserved between debug sessions.

You can open the dialog box from the context menu available in the editor window, **Breakpoints** window, and in the **Disassembly** window.

To set a new breakpoint:

- 1 Choose **View>Breakpoints** to open the **Breakpoints** window.
- 2 In the **Breakpoints** window, right-click, and choose **New Breakpoint** from the context menu.
- 3 On the submenu, choose the breakpoint type you want to set. Depending on the C-SPY driver you are using, different breakpoint types are available.
- 4 In the breakpoint dialog box that appears, specify the breakpoint settings and click **OK**.

The breakpoint is displayed in the **Breakpoints** window.

To modify an existing breakpoint:

- 1 In the **Breakpoints** window, editor window, or in the **Disassembly** window, select the breakpoint you want to modify and right-click to open the context menu.

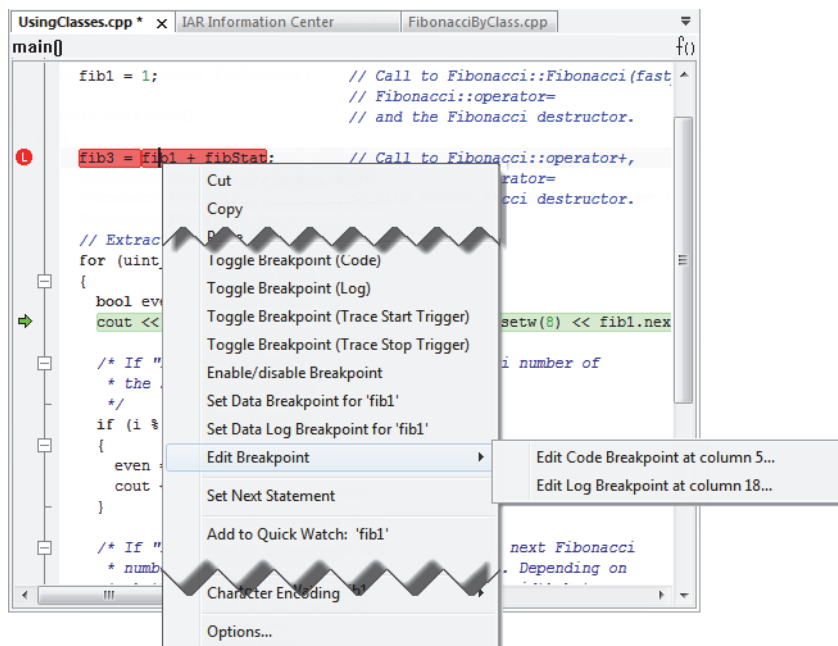

If there are several breakpoints on the same source code line, the breakpoints will be listed on a submenu.

- 2 On the context menu, choose the appropriate command.
- 3 In the breakpoint dialog box that appears, specify the breakpoint settings and click **OK**.

The breakpoint is displayed in the **Breakpoints** window.

SETTING A DATA BREAKPOINT IN THE MEMORY WINDOW

You can set breakpoints directly on a memory location in the **Memory** window. Right-click in the window and choose the breakpoint command from the context menu that appears. To set the breakpoint on a range, select a portion of the memory contents.

The breakpoint is not highlighted in the **Memory** window; instead, you can see, edit, and remove it using the **Breakpoints** window, which is available from the **View** menu. The breakpoints you set in the **Memory** window will be triggered for both read and

write accesses. All breakpoints defined in this window are preserved between debug sessions.

Note: Setting breakpoints directly in the **Memory** window is only possible if the driver you use supports this.

SETTING BREAKPOINTS USING SYSTEM MACROS

You can set breakpoints not only in the breakpoint dialog box but also by using built-in C-SPY system macros. When you use system macros for setting breakpoints, the breakpoint characteristics are specified as macro parameters.

Macros are useful when you have already specified your breakpoints so that they fully meet your requirements. You can define your breakpoints in a macro file, using built-in system macros, and execute the file at C-SPY startup. The breakpoints will then be set automatically each time you start C-SPY. Another advantage is that the debug session will be documented, and that several engineers involved in the development project can share the macro files.

Note: If you use system macros for setting breakpoints, you can still view and modify them in the **Breakpoints** window. In contrast to using the dialog box for defining breakpoints, all breakpoints that are defined using system macros are removed when you exit the debug session.

These breakpoint macros are available:

C-SPY macro for breakpoints	Simulator	FET Debugger
<code>__setAdvancedTriggerBreak</code>	—	Yes
<code>__setCodeBreak</code>	Yes	Yes
<code>__setConditionalBreak</code>	—	Yes
<code>__setDataBreak</code>	Yes	—
<code>__setLogBreak</code>	Yes	Yes
<code>__setRangeBreak</code>	—	Yes
<code>__setDataLogBreak</code>	Yes	—
<code>__setSimBreak</code>	Yes	—
<code>__setTraceStartBreak</code>	Yes	—
<code>__setTraceStopBreak</code>	Yes	—
<code>__clearBreak</code>	Yes	Yes

Table 6: C-SPY macros for breakpoints

For information about each breakpoint macro, see *Reference information on C-SPY system macros*, page 325.

Setting breakpoints at C-SPY startup using a setup macro file

You can use a setup macro file to define breakpoints at C-SPY startup. Follow the procedure described in *Using C-SPY macros*, page 313.

USEFUL BREAKPOINT HINTS

Below are some useful hints related to setting breakpoints.



Tracing incorrect function arguments

If a function with a pointer argument is sometimes incorrectly called with a `NULL` argument, you might want to debug that behavior. These methods can be useful:

- Set a breakpoint on the first line of the function with a condition that is true only when the parameter is 0. The breakpoint will then not be triggered until the problematic situation actually occurs. The advantage of this method is that no extra source code is needed. The drawback is that the execution speed might become unacceptably low.
- You can use the `assert` macro in your problematic function, for example:

```
int MyFunction(int * MyPtr)
{
    assert(MyPtr != 0); /* Assert macro added to your source
                        code. */
    /* Here comes the rest of your function. */
}
```

The execution will break whenever the condition is true. The advantage is that the execution speed is only slightly affected, but the drawback is that you will get a small extra footprint in your source code. In addition, the only way to get rid of the execution stop is to remove the macro and rebuild your source code.

- Instead of using the `assert` macro, you can modify your function like this:

```
int MyFunction(int * MyPtr)
{
    if(MyPtr == 0)
        MyDummyStatement; /* Dummy statement where you set a
                            breakpoint. */
    /* Here comes the rest of your function. */
}
```

You must also set a breakpoint on the extra dummy statement, so that the execution will break whenever the condition is true. The advantage is that the execution speed is only very slightly affected, but the drawback is that you will still get a small extra footprint in your source code. However, in this way you can get rid of the execution stop by just removing the breakpoint.



Performing a task and continuing execution

You can perform a task when a breakpoint is triggered and then automatically continue execution.

You can use the **Action** text box to associate an action with the breakpoint, for instance a C-SPY macro function. When the breakpoint is triggered and the execution of your application has stopped, the macro function will be executed. In this case, the execution will not continue automatically.

Instead, you can set a condition which returns 0 (false). When the breakpoint is triggered, the condition—which can be a call to a C-SPY macro that performs a task—is evaluated and because it is not true, execution continues.

Consider this example where the C-SPY macro function performs a simple task:

```

__var my_counter;

count ()
{
    my_counter += 1;
    return 0;
}

```

To use this function as a condition for the breakpoint, type `count ()` in the **Expression** text box under **Conditions**. The task will then be performed when the breakpoint is triggered. Because the macro function `count` returns 0, the condition is false and the execution of the program will resume automatically, without any stop.



Using breakpoints when programming flash memory

When programming the flash memory, do not set a breakpoint on the instruction immediately following the *write to flash* operation. A simple work-around is to follow the *write to flash* operation with a `NOP` instruction, and set a breakpoint on the instruction following the `NOP` instruction.

Reference information on breakpoints

Reference information about:

- *Breakpoints window*, page 119
- *Breakpoint Usage window*, page 121
- *Code breakpoints dialog box*, page 122
- *Log breakpoints dialog box*, page 123
- *Data breakpoints dialog box*, page 125

- *Data Log breakpoints dialog box*, page 127
- *Immediate breakpoints dialog box*, page 128
- *Range breakpoints dialog box*, page 129
- *Conditional breakpoints dialog box*, page 131
- *Advanced Trigger breakpoints dialog box*, page 134
- *Enter Location dialog box*, page 136
- *Breakpoint combiner dialog box*, page 137
- *Resolve Source Ambiguity dialog box*, page 138

See also:

- *Reference information on C-SPY system macros*, page 325
- *Reference information on trace*, page 184

Breakpoints window

The **Breakpoints** window is available from the **View** menu.

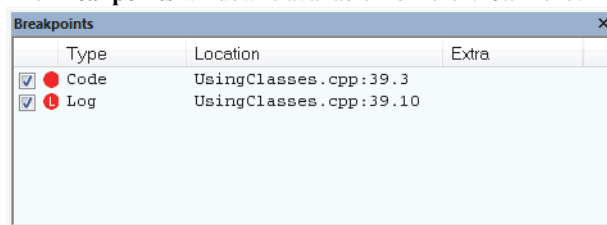

This window lists all breakpoints you define.

Use this window to conveniently monitor, enable, and disable breakpoints; you can also define new breakpoints and modify existing breakpoints.

Requirements

Can be used with all C-SPY debugger drivers and debug probes.

Display area

This area lists all breakpoints you define. For each breakpoint, information about the breakpoint type, source file, source line, and source column is provided.

Context menu

This context menu is available:

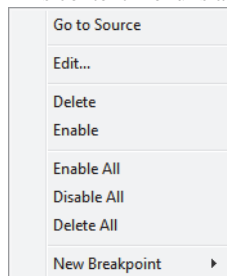

These commands are available:

Go to Source

Moves the insertion point to the location of the breakpoint, if the breakpoint has a source location. Double-click a breakpoint in the **Breakpoints** window to perform the same command.

Edit

Opens the breakpoint dialog box for the breakpoint you selected.

Delete

Deletes the breakpoint. Press the Delete key to perform the same command.

Enable

Enables the breakpoint. The check box at the beginning of the line will be selected. You can also perform the command by manually selecting the check box. This command is only available if the breakpoint is disabled.

Disable

Disables the breakpoint. The check box at the beginning of the line will be deselected. You can also perform this command by manually deselecting the check box. This command is only available if the breakpoint is enabled.

Enable All

Enables all defined breakpoints.

Disable All

Disables all defined breakpoints.

Delete All

Deletes all defined breakpoints.

New Breakpoint

Displays a submenu where you can open the breakpoint dialog box for the available breakpoint types. All breakpoints you define using this dialog box are preserved between debug sessions.

Breakpoint Usage window

The **Breakpoint Usage** window is available from the menu specific to the C-SPY driver you are using.

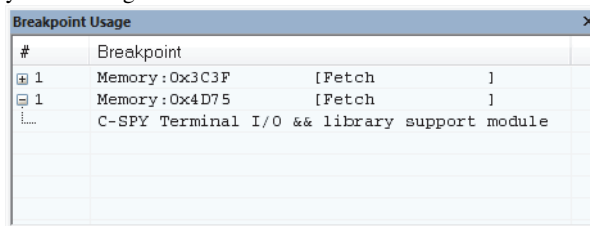

#	Breakpoint
1	Memory: 0x3C3F [Fetch]
1	Memory: 0x4D75 [Fetch]
...	C-SPY Terminal I/O && library support module

This window lists all breakpoints currently set in the target system, both the ones you have defined and the ones used internally by C-SPY. The format of the items in this window depends on the C-SPY driver you are using.

The window gives a low-level view of all breakpoints, related but not identical to the list of breakpoints displayed in the **Breakpoints** window.

C-SPY uses breakpoints when stepping. Use the **Breakpoint Usage** window for:

- Identifying all breakpoint consumers
- Checking that the number of active breakpoints is supported by the target system
- Configuring the debugger to use the available breakpoints in a better way, if possible.

For more information, see *Breakpoints in the C-SPY FET debugger driver*, page 111.

Requirements

Can be used with all C-SPY debugger drivers and debug probes.

Display area

For each breakpoint in the list, the address and access type are displayed. Each breakpoint in the list can also be expanded to show its originator.

Code breakpoints dialog box

The **Code** breakpoints dialog box is available from the context menu in the editor window, **Breakpoints** window, and in the **Disassembly** window.

This figure reflects the C-SPY simulator.

Use the **Code** breakpoints dialog box to set a code breakpoint, see *Setting breakpoints using the dialog box*, page 114.

Break At

Specify the code location of the breakpoint in the text box. Alternatively, click the **Edit** button to open the **Enter Location** dialog box, see *Enter Location dialog box*, page 136.

Size

Determines whether there should be a size—in practice, a range—of locations where the breakpoint will trigger. Each fetch access to the specified memory range will trigger the breakpoint. Select how to specify the size:

Auto

The size will be set automatically, typically to 1.

Manual

Specify the size of the breakpoint range in the text box.

Note: This option might not be supported by the combination of C-SPY driver and device that you are using.

Action

Specify a valid C-SPY expression, which is evaluated when the breakpoint is triggered and the condition is true. For more information, see *Useful breakpoint hints*, page 117.

Conditions

Specify simple or complex conditions:

Expression

Specify a valid C-SPY expression, see *C-SPY expressions*, page 82.

Condition true

The breakpoint is triggered if the value of the expression is true.

Condition changed

The breakpoint is triggered if the value of the expression has changed since it was last evaluated.

Skip count

The number of times that the breakpoint condition must be fulfilled before the breakpoint starts triggering. After that, the breakpoint will trigger every time the condition is fulfilled.

Log breakpoints dialog box

The **Log** breakpoints dialog box is available from the context menu in the editor window, **Breakpoints** window, and in the **Disassembly** window.

The screenshot shows a dialog box titled "Log". It has a red icon in the top-left corner. The dialog contains the following elements:

- Trigger at:** A text input field with an "Edit..." button to its right.
- Message:** A text input field with a checkbox labeled "C-Spy macro \"_message\" style" to its left.
- Conditions:** A section containing an "Expression:" text input field and two radio buttons: "Condition true" (which is selected) and "Condition changed".

This figure reflects the C-SPY simulator.

Use the **Log** breakpoints dialog box to set a log breakpoint, see *Setting breakpoints using the dialog box*, page 114.

Requirements

The C-SPY simulator.

Trigger at

Specify the code location of the breakpoint. Alternatively, click the **Edit** button to open the **Enter Location** dialog box, see *Enter Location dialog box*, page 136.

Message

Specify the message you want to be displayed in the C-SPY **Debug Log** window. The message can either be plain text, or—if you also select the option **C-SPY macro** "**__message**" **style**—a comma-separated list of arguments.

C-SPY macro "**__message**" style

Select this option to make a comma-separated list of arguments specified in the **Message** text box be treated exactly as the arguments to the C-SPY macro language statement `__message`, see *Formatted output*, page 321.

Conditions

Specify simple or complex conditions:

Expression

Specify a valid C-SPY expression, see *C-SPY expressions*, page 82.

Condition true

The breakpoint is triggered if the value of the expression is true.

Condition changed

The breakpoint is triggered if the value of the expression has changed since it was last evaluated.

Data breakpoints dialog box

The **Data** breakpoints dialog box is available from the context menu in the editor window, **Breakpoints** window, the **Memory** window, and in the **Disassembly** window.

This figure reflects the C-SPY simulator.

Use the **Data** breakpoints dialog box to set a data breakpoint, see *Setting breakpoints using the dialog box*, page 114. Data breakpoints never stop execution within a single instruction. They are recorded and reported after the instruction is executed.

Requirements

The C-SPY simulator.

Break At

Specify the data location of the breakpoint in the text box. Alternatively, click the **Edit** button to open the **Enter Location** dialog box, see *Enter Location dialog box*, page 136.

Access Type

Selects the type of memory access that triggers the breakpoint:

Read/Write

Reads from or writes to location.

Read

Reads from location.

Write

Writes to location.

Size

Determines whether there should be a size—in practice, a range—of locations where the breakpoint will trigger. Each fetch access to the specified memory range will trigger the breakpoint. Select how to specify the size:

Auto

The size will automatically be based on the type of expression the breakpoint is set on. For example, if you set the breakpoint on a 12-byte structure, the size of the breakpoint will be 12 bytes.

Manual

Specify the size of the breakpoint range in the text box.

For data breakpoints, this can be useful if you want the breakpoint to be triggered on accesses to data structures, such as arrays, structs, and unions.

Action

Specify a valid C-SPY expression, which is evaluated when the breakpoint is triggered and the condition is true. For more information, see *Useful breakpoint hints*, page 117.

Conditions

Specify simple or complex conditions:

Expression

Specify a valid C-SPY expression, see *C-SPY expressions*, page 82.

Condition true

The breakpoint is triggered if the value of the expression is true.

Condition changed

The breakpoint is triggered if the value of the expression has changed since it was last evaluated.

Skip count

The number of times that the breakpoint condition must be fulfilled before the breakpoint starts triggering. After that, the breakpoint will trigger every time the condition is fulfilled.

Data Log breakpoints dialog box

The **Data Log** breakpoints dialog box is available from the context menu in the **Breakpoints** window.

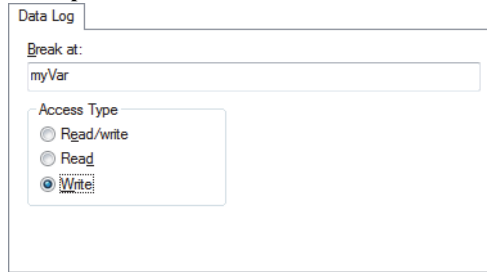

This figure reflects the C-SPY simulator.

Use the **Data Log** breakpoints dialog box to set a maximum of four data log breakpoints on memory addresses, see *Setting breakpoints using the dialog box*, page 114.

See also *Data Log breakpoints*, page 109 and *Getting started using data logging*, page 200.

Requirements

The C-SPY simulator.

Break At

Specify a memory location as a variable (with static storage duration) or as an address.

Access Type

Selects the type of access to the variable that generates a log entry:

Read/Write

Read and write accesses from or writes to location of the variable.

Read

Read accesses from the location of the variable.

Write

Write accesses to location of the variable.

Immediate breakpoints dialog box

The **Immediate** breakpoints dialog box is available from the context menu in the editor window, **Breakpoints** window, the **Memory** window, and in the **Disassembly** window.

In the C-SPY simulator, you can use the **Immediate** breakpoints dialog box to set an immediate breakpoint, see *Setting breakpoints using the dialog box*, page 114. Immediate breakpoints do not stop execution at all; they only suspend it temporarily.

Requirements

The C-SPY simulator.

Trigger at

Specify the data location of the breakpoint. Alternatively, click the **Edit** button to open the **Enter Location** dialog box, see *Enter Location dialog box*, page 136.

Access Type

Selects the type of memory access that triggers the breakpoint:

Read

Reads from location.

Write

Writes to location.

Action

Specify a valid C-SPY expression, which is evaluated when the breakpoint is triggered and the condition is true. For more information, see *Useful breakpoint hints*, page 117.

Range breakpoints dialog box

The **Range** breakpoints dialog box is available from the context menu in the **Breakpoints** window and the **Memory** window.

Use the **Range** breakpoints dialog box to set a range breakpoint.

Range breakpoints are available for the C-SPY FET Debugger driver on devices that support the Enhanced Emulation Module at the required level.

Requirements

The C-SPY FET Debugger driver.

Start value

Specify the start value for the range breakpoint in the **Start value** text box; an expression, an absolute address, or a source location. Alternatively, click the **Edit** button to open the **Enter Location** dialog box, see *Enter Location dialog box*, page 136.

Range delimiter

Sets the end location of the range. Choose the type of delimiter and specify the value in the text box:

End value

The same type of value as for the **Start value**.

Length

The length of the range in bytes (in hexadecimal notation).

Automatic

Bases the range automatically on the type of expression the breakpoint is set on. For example, if you set the breakpoint on a 12-byte structure, the range of the breakpoint will be 12 bytes.

Type

Selects which breakpoint type to use:

Address (MAB)

Sets a breakpoint on a specified address, or anything that can be evaluated to one. The breakpoint is triggered when the specified location is accessed. If you have set the breakpoint on a specific machine instruction, the breakpoint will be triggered and the execution will stop exactly before the instruction will be executed.

Data (MDB)

Sets a breakpoint on a specified value. It is the value on the data bus that triggers the breakpoint.

Access type

Selects the type of access that triggers the selected breakpoint:

Read

Read from location.

Write

Write to location.

Read/Write

Read from or write to location.

Fetch

At instruction fetch.

Action

Selects the action that occurs when the breakpoint is triggered:

Break

The execution stops when the breakpoint is triggered.

State Storage Trigger

Defines the breakpoint as a state storage trigger. To control the behavior of the state storage module, see *State Storage Control window*, page 301.

Action when

Selects when the action shall occur:

Inside range

The action occurs at an access inside the specified range.

Outside range

The action occurs at an access outside of the specified range.

Conditional breakpoints dialog box

The **Conditional** breakpoints dialog box is available from the context menu in the **Breakpoints** window and the **Disassembly** window.

Use the **Conditional** breakpoints dialog box to set a conditional breakpoint.

Conditional breakpoints are available for the C-SPY FET Debugger driver on devices that support the Enhanced Emulation Module at the required level.

Requirements

The C-SPY FET Debugger driver.

Break At

Specify the location for the breakpoint in the **Break At** text box. Alternatively, click the **Edit** button to open the **Enter Location** dialog box, see *Enter Location dialog box*, page 136.

Type

Selects which breakpoint type to use:

Address bus (MAB)

Sets a breakpoint on the address specified in the **Break At** text box, or anything that can be evaluated to one. The breakpoint is triggered when the specified location is accessed. If you have set the breakpoint on a specific machine instruction, the breakpoint will be triggered and the execution will stop exactly before the instruction will be executed.

Data bus (MDB)

Sets a breakpoint on a specified value. It is the value on the data bus that triggers the breakpoint.

Register

Sets a breakpoint on a register. Specify the register, or anything that can be evaluated to such, in the **Break At** text box. In the **Register Value** text box, type the value that should trigger the breakpoint.

Operator

Selects a condition operator for when the breakpoint should be triggered:

==

Equal to.

>=

Greater than or equal to.

<=

Less than or equal to.

!=

Not equal to.

Access

Selects the type of access that triggers the selected breakpoint:

Read

Read from location.

Write

Write to location.

Read/Write

Read from or write to location.

Fetch

At instruction fetch.

Mask

Specify a bit mask value that the breakpoint address or value will be masked with. (On the FET hardware the mask is inverted, but this is *not* the case in the FET Debugger driver.)

Condition

Optionally, specify an additional condition to a conditional breakpoint. This means that a conditional breakpoint can be a single data breakpoint or a combination of two breakpoints that must occur at the same time. These settings can be specified for the additional condition:

Value

The extra conditional data value.

Mask

The bit mask value that the breakpoint value will be masked with.

Operator

The operator of condition, either ==, >=, <=, or !=.

Access

The access type of the condition, either **Read**, **Write**, or **Read/Write**.

Action

Selects the action that occurs when the breakpoint is triggered:

Break

The execution stops when the breakpoint is triggered.

State Storage Trigger

State storage starts when the breakpoint is triggered. To control the behavior of the state storage module, see *State Storage Control window*, page 301.

Cycle Counter Trigger

Starts, stops, resets, or counts the Cycle counter 1. To control the behavior of the cycle counter, see *The advanced cycle counter*, page 291.

Advanced Trigger breakpoints dialog box

The **Advanced Trigger** breakpoints dialog box is available from the context menu in the **Breakpoints** window and the **Disassembly** window.

Use the **Advanced Trigger** breakpoints dialog box to set an advanced trigger breakpoint.

Advanced trigger breakpoints are available for the C-SPY FET Debugger driver on devices that support the Enhanced Emulation Module at the required level.

Requirements

The C-SPY FET Debugger driver.

Break At

Specify the location for the breakpoint in the **Break At** text box. Alternatively, click the **Edit** button to open the **Enter Location** dialog box, see *Enter Location dialog box*, page 136.

Type

Selects which breakpoint type to use:

Address bus (MAB)

Sets a breakpoint on a specified address, or anything that can be evaluated to one. The breakpoint is triggered when the specified location is accessed. If you have set the breakpoint on a specific machine instruction, the breakpoint will be triggered and the execution will stop exactly before the instruction will be executed.

Data bus (MDB)

Sets a breakpoint on a specified value. It is the value on the data bus that triggers the breakpoint.

Register

Sets a breakpoint on a register. Specify the register, or anything that can be evaluated to such, in the **Break At** text box. In the **Value** text box, type the value that should trigger the breakpoint.

Operator

Selects a condition operator for when the breakpoint should be triggered:

==

Equal to.

>=

Greater than or equal to.

<=

Less than or equal to.

!=

Not equal to.

Mask

Specify a bit mask value that the breakpoint address or value will be masked with. (On the FET hardware the mask is inverted, but this is *not* the case in the FET Debugger driver.)

Value

Specify the data value in the specified register that should be triggered.

Access type

Selects the type of access that triggers the selected breakpoint.

Action

Selects the action that occurs when the breakpoint is triggered:

Break

The execution stops when the breakpoint is triggered.

State Storage Trigger

State storage starts when the breakpoint is triggered. To control the behavior of the state storage module, see *State Storage Control window*, page 301.

Cycle Counter Trigger

Starts, stops, resets, or counts the Cycle counter 1. To control the behavior of the cycle counter, see *The advanced cycle counter*, page 291.

Enter Location dialog box

The **Enter Location** dialog box is available from the breakpoints dialog box, either when you set a new breakpoint or when you edit a breakpoint.

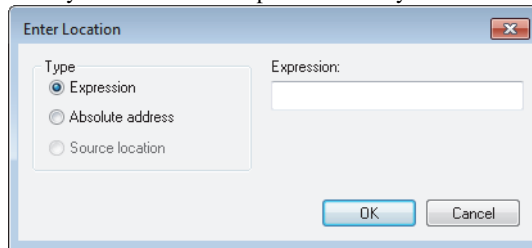

Use the **Enter Location** dialog box to specify the location of the breakpoint.

Note: This dialog box looks different depending on the **Type** you select.

Type

Selects the type of location to be used for the breakpoint, choose between:

Expression

A C-SPY expression, whose value evaluates to a valid code or data location.

A code location, for example the function `main`, is typically used for code breakpoints.

A data location is the name of a variable and is typically used for data breakpoints. For example, `my_var` refers to the location of the variable `my_var`, and `arr[3]` refers to the location of the fourth element of the array `arr`. For static variables declared with the same name in several functions, use the syntax `my_func::my_static_variable` to refer to a specific variable.

For more information about C-SPY expressions, see *C-SPY expressions*, page 82.

Absolute address

An absolute location on the form *zone:hexaddress* or simply *hexaddress* (for example `Memory:0x42`). *zone* refers to C-SPY memory zones and specifies in which memory the address belongs, see *C-SPY memory zones*, page 142.

Source location

A location in your C source code using the syntax:

```
{filename}.row.column.
```

filename specifies the filename and full path.

row specifies the row in which you want the breakpoint.

column specifies the column in which you want the breakpoint.

For example, `{C:\src\prog.c}.22.3` sets a breakpoint on the third character position on row 22 in the source file `prog.c`. Note that in quoted form, for example in a C-SPY macro, you must instead write

```
{C:\\src\\prog.c}.22.3.
```

Note that the Source location type is usually meaningful only for code locations in code breakpoints. Depending on the C-SPY driver you are using, **Source location** might not be available for data and immediate breakpoints.

Breakpoint combiner dialog box

The **Breakpoint combiner** dialog box is available from the **Emulator** menu.

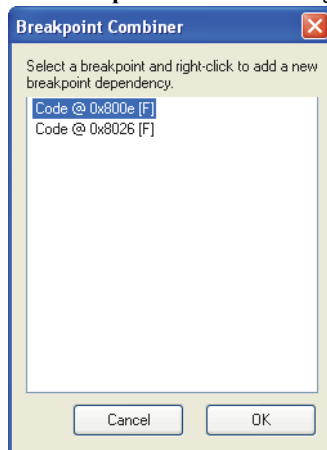

Use this dialog box to combine two already defined breakpoints.

Select a breakpoint and right-click to display a list of breakpoints to combine it with. When two breakpoints have been combined, the defined action will not occur until both breakpoints have been reached.

Note: Only available for devices that support the Enhanced Emulation Module at the required level. The settings are not saved when the debug session is closed.

Requirements

The C-SPY FET Debugger driver.

Resolve Source Ambiguity dialog box

The **Resolve Source Ambiguity** dialog box appears, for example, when you try to set a breakpoint on templates and the source location corresponds to more than one function.

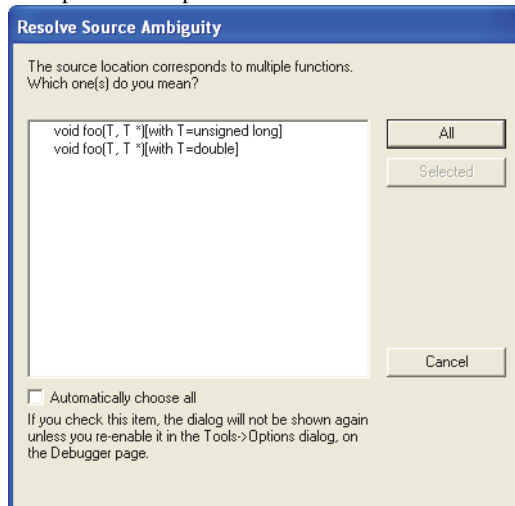

To resolve a source ambiguity, perform one of these actions:

- In the text box, select one or several of the listed locations and click **Selected**.
- Click **All**.

All

The breakpoint will be set on all listed locations.

Selected

The breakpoint will be set on the source locations that you have selected in the text box.

Cancel

No location will be used.

Automatically choose all

Determines that whenever a specified source location corresponds to more than one function, all locations will be used.

Note that this option can also be specified in the **IDE Options** dialog box, see Debugger options in the *IDE Project Management and Building Guide for MSP430*.

Memory and registers

- Introduction to monitoring memory and registers
- Monitoring memory and registers
- Reference information on memory and registers

Introduction to monitoring memory and registers

These topics are covered:

- Briefly about monitoring memory and registers
- C-SPY memory zones
- Memory configuration for the C-SPY simulator

BRIEFLY ABOUT MONITORING MEMORY AND REGISTERS

C-SPY provides many windows for monitoring memory and registers, most of them available from the **View** menu:

- The **Memory** window
Gives an up-to-date display of a specified area of memory—a memory zone—and allows you to edit it. *Data coverage* along with execution of your application is highlighted with different colors. You can fill specified areas with specific values and you can set breakpoints directly on a memory location or range. You can open several instances of this window, to monitor different memory areas. The content of the window can be regularly updated while your application is executing.
- The **Symbolic Memory** window
Displays how variables with static storage duration are laid out in memory. This can be useful for better understanding memory usage or for investigating problems caused by variables being overwritten, for example by buffer overruns.
- The **Stack** window
Displays the contents of the stack, including how stack variables are laid out in memory. In addition, integrity checks of the stack can be performed to detect and warn about problems with stack overflow. For example, the **Stack** window is useful for determining the optimal size of the stack. You can open up to two instances of this window, each showing different stacks or different display modes of the same stack.

- The **Registers** window

Gives an up-to-date display of the contents of the processor registers and SFRs, and allows you to edit them. Because of the large amount of registers—memory-mapped peripheral unit registers and CPU registers—it is inconvenient to show all registers concurrently in the **Registers** window. Instead you can divide registers into *application-specific groups*. You can choose to load either predefined register groups or define your own groups. You can open several instances of this window, each showing a different register group.

- The **SFR Setup** window

Displays the currently defined SFRs that C-SPY has information about, both factory-defined (retrieved from the device description file) and custom-defined SFRs. If required, you can use the **Edit SFR** dialog box to customize the SFR definitions.

To view the memory contents for a specific variable, simply drag the variable to the **Memory** window or the **Symbolic Memory** window. The memory area where the variable is located will appear.



Reading the value of some registers might influence the runtime behavior of your application. For example, reading the value of a UART status register might reset a pending bit, which leads to the lack of an interrupt that would have processed a received byte. To prevent this from happening, make sure that the **Registers** window containing any such registers is closed when debugging a running application.

C-SPY MEMORY ZONES

In C-SPY, the term *zone* is used for a named memory area. A memory address, or *location*, is a combination of a zone and a numerical offset into that zone. The MSP430

architecture has only one zone, `Memory`, which covers the whole MSP430 memory range.

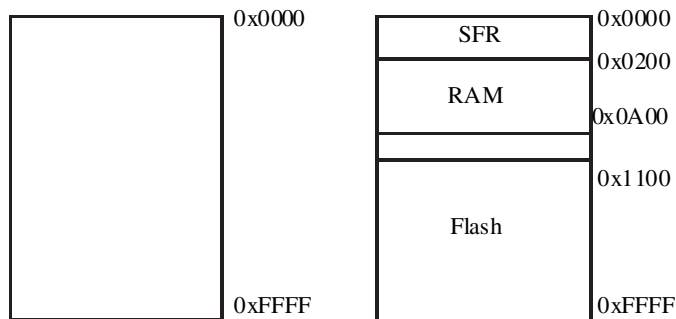

Default zone `Memory`

Additional zones for MSP430F149

Memory zones are used in several contexts, most importantly in the **Memory** and **Disassembly** windows, and in C-SPY macros. In the windows, use the **Zone** box to choose which memory zone to display.

Device-specific zones

Memory information for device-specific zones is defined in the *device description files*. When you load a device description file, additional zones that adhere to the specific memory layout become available.

See the device description file for information about available memory zones.

These zones are available, depending on the device description file you are using: `SFR`, `RAM`, `INFO`, and `Flash`. Some devices have `FRAM` instead of `Flash`.

If your hardware does not have the same memory layout as any of the predefined device description files, you can define customized zones by adding them to the file.

For more information, see *Selecting a device description file*, page 44 and *Modifying a device description file*, page 48.

MEMORY CONFIGURATION FOR THE C-SPY SIMULATOR

To simulate the target system properly, the C-SPY simulator needs information about the memory configuration. By default, C-SPY uses a configuration based on information retrieved from the device description file.

The C-SPY simulator provides various mechanisms to improve the configuration further:

- If the default memory configuration does not specify the required memory address ranges, you can specify the memory address ranges shall be based on:
 - The zones predefined in the device description file
 - The section information available in the debug file
 - Or, you can define your own memory address ranges, which you typically might want to do if the files do not specify memory ranges for the *specific* device that you are using, but instead for a *family* of devices (perhaps with various amounts of on-chip RAM).
- For each memory address range, you can specify an *access type*. If a memory access occurs that does not agree with the specified access type, C-SPY will regard this as an illegal access and warn about it. In addition, an access to memory that is not defined is regarded as an illegal access. The purpose of memory access checking is to help you to identify memory access violations.

For more information, see *Memory Access Setup dialog box*, page 173.

Monitoring memory and registers

These tasks are covered:

- Defining application-specific register groups
- Monitoring stack usage

DEFINING APPLICATION-SPECIFIC REGISTER GROUPS

Defining application-specific register groups minimizes the amount of registers displayed in the **Registers** windows and makes the debugging easier.

To define application-specific register groups:

- 1 Choose **View>Registers>Register User Groups Setup** during a debug session.

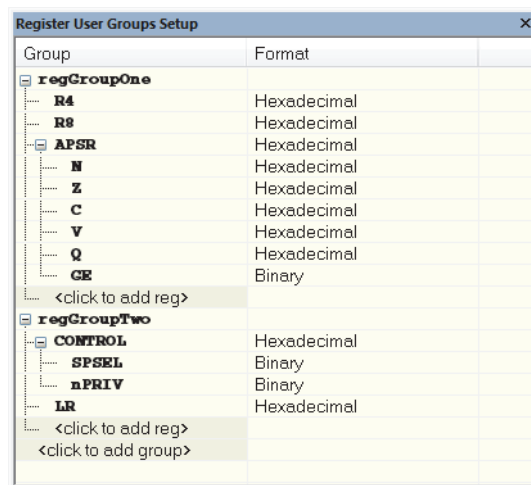

Right-clicking in the window displays a context menu with commands. For information about these commands, see *Register User Groups Setup window*, page 166.

- 2 Click on <click to add group> and specify the name of your group, for example **My Timer Group** and press Enter.
- 3 Underneath the group name, click on <click to add reg> and type the name of a register, and press Enter. You can also drag a register name from another window in the IDE. Repeat this for all registers that you want to add to your group.
- 4 As an optional step, right-click any registers for which you want to change the integer base, and choose **Format** from the context menu to select a suitable base.
- 5 When you are done, your new group is now available in the **Registers** windows.

If you want to define more application-specific groups, repeat this procedure for each group you want to define.

Note: If a certain SFR that you need cannot be added to a group, you can register your own SFRs. For more information, see *SFR Setup window*, page 168.

MONITORING STACK USAGE

These are the two main use cases for the **Stack** window:

- Monitoring stack memory usage
- Monitoring the stack memory content.

In both cases, C-SPY retrieves information about the defined stack size and its allocation from the definition in the linker configuration file of the segment holding the stack. If you, for some reason, have modified the stack initialization in the system startup code, `cstartup`, you should also change the segment definition in the linker configuration file accordingly, otherwise the **Stack** window cannot track the stack usage. For more information, see the *IAR C/C++ Compiler User Guide for MSP430*.

To monitor stack memory usage:

1 Before you start C-SPY, choose **Tools>Options**. On the **Stack** page:

- Select **Enable graphical stack display and stack usage tracking**. This option also enables the option **Warn when exceeding stack threshold**. Specify a suitable threshold value.
- Note also the option **Warn when stack pointer is out of bounds**. Any such warnings are displayed in the **Debug Log** window.

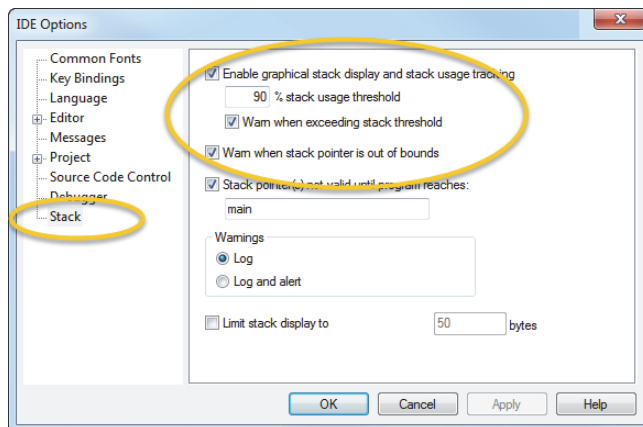

2 Start C-SPY.

When your application is first loaded, and upon each reset, the memory for the stack area is filled with the dedicated byte value `0xCD` before the application starts executing.

3 Choose **View>Stack>Stack 1** to open the **Stack** window.

Note that you can open up to two **Stack** windows, each showing a different stack—if several stacks are available—or the same stack with different display settings.

4 Start executing your application.

Whenever execution stops, the stack memory is searched from the end of the stack until a byte whose value is not `0xCD` is found, which is assumed to be how far the stack has been used. The light gray area of the stack bar represents the *unused* stack memory area, whereas the dark gray area of the bar represents the *used* stack memory.

For this example, you can see that only 44% of the reserved memory address range was used, which means that it could be worth considering decreasing the size of memory:

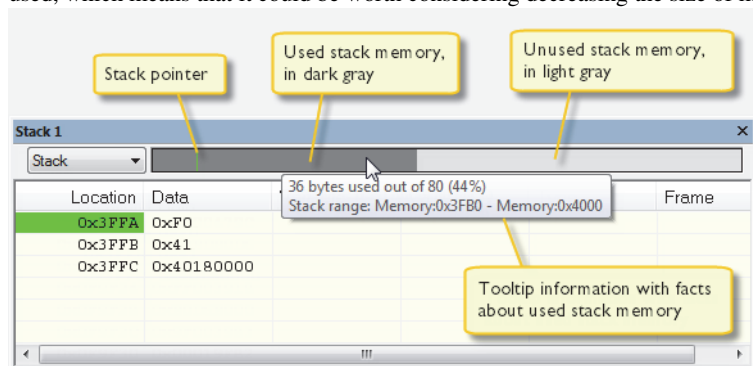

Note: Although this is a reasonably reliable way to track stack usage, there is no guarantee that a stack overflow is detected. For example, a stack *can* incorrectly grow outside its bounds, and even modify memory outside the stack area, without actually modifying any of the bytes near the end of the stack range. Likewise, your application might modify memory within the stack area by mistake.

See also the *IAR C/C++ Compiler User Guide for MSP430*.

To monitor the stack memory content:

- 1 Before you start monitoring stack memory, you might want to disable the option **Enable graphical stack display and stack usage tracking** to improve performance during debugging.
- 2 Start C-SPY.
- 3 Choose **View>Stack>Stack 1** to open the **Stack** window.

Note that you can access various context menus in the display area from where you can change display format, etc.

- 4 Start executing your application.

Whenever execution stops, you can monitor the stack memory, for example to see function parameters that are passed on the stack:

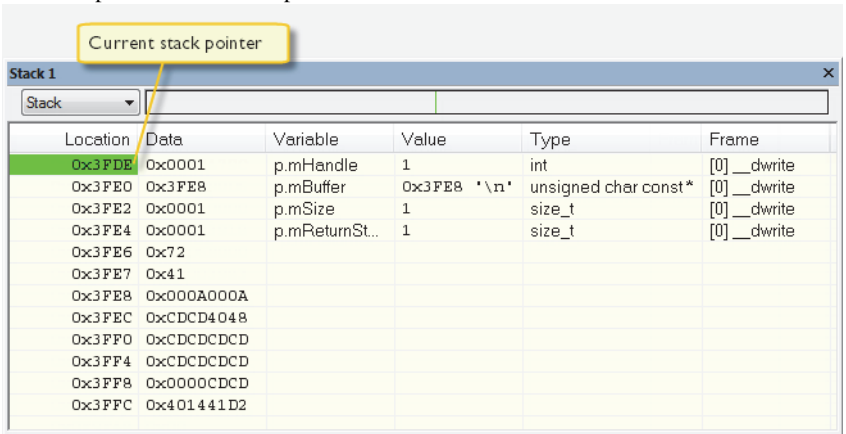

Location	Data	Variable	Value	Type	Frame
0x3FDE	0x0001	p.mHandle	1	int	[0] __dwrite
0x3FEO	0x3FE8	p.mBuffer	0x3FE8 '\n'	unsigned char const*	[0] __dwrite
0x3FE2	0x0001	p.mSize	1	size_t	[0] __dwrite
0x3FE4	0x0001	p.mReturnSt...	1	size_t	[0] __dwrite
0x3FE6	0x72				
0x3FE7	0x41				
0x3FE8	0x000A000A				
0x3FEC	0xCDCD4048				
0x3FF0	0xCDCDCDCD				
0x3FF4	0xCDCDCDCD				
0x3FF8	0x0000CDCD				
0x3FFC	0x401441D2				

Reference information on memory and registers

Reference information about:

- *Memory window*, page 149
- *Memory Save dialog box*, page 153
- *Memory Restore dialog box*, page 154
- *Fill dialog box*, page 155
- *Symbolic Memory window*, page 156
- *Stack window*, page 159
- *Registers window*, page 163
- *Register User Groups Setup window*, page 166
- *SFR Setup window*, page 168
- *Edit SFR dialog box*, page 171
- *Memory Access Setup dialog box*, page 173
- *Edit Memory Access dialog box*, page 175
- *Memory Dump dialog box*, page 176

Memory window

The **Memory** window is available from the **View** menu.

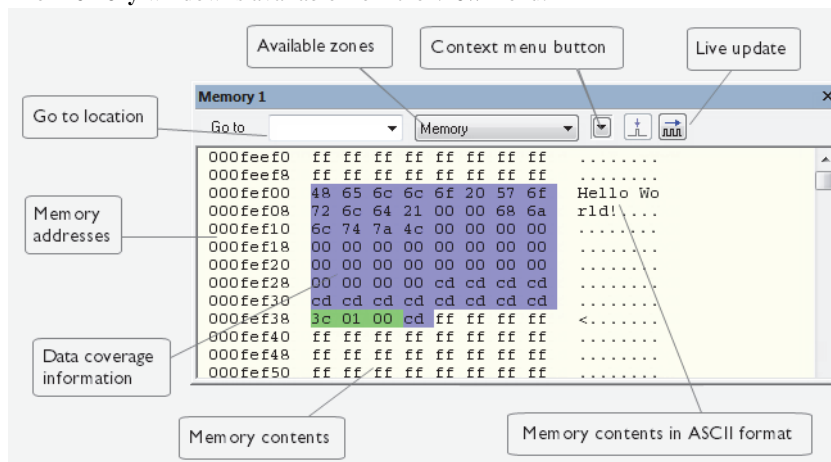

This window gives an up-to-date display of a specified area of memory—a memory zone—and allows you to edit it. You can open several instances of this window, which is very convenient if you want to keep track of several memory or register zones, or monitor different parts of the memory.



To view the memory corresponding to a variable, you can select it in the editor window and drag it to the **Memory** window.

See also *Editing in C-SPY windows*, page 47.

Requirements

Can be used with all C-SPY debugger drivers and debug probes.

Toolbar

The toolbar contains:

Go to

The memory location or symbol you want to view.

Zone

Selects a memory zone, see *C-SPY memory zones*, page 142.

Context menu button

Displays the context menu.

Update Now

Updates the content of the **Memory** window while your application is executing. This button is only enabled if the C-SPY driver you are using has access to the target system memory while your application is executing.

Live Update

Updates the contents of the **Memory** window regularly while your application is executing. This button is only enabled if the C-SPY driver you are using has access to the target system memory while your application is executing. To set the update frequency, specify an appropriate frequency in the **IDE Options>Debugger** dialog box.

Display area

The display area shows the addresses currently being viewed, the memory contents in the format you have chosen, and—provided that the display mode is set to **1x Units**—the memory contents in ASCII format. You can edit the contents of the display area, both in the hexadecimal part and the ASCII part of the area.

Data coverage is displayed with these colors:

Yellow	Indicates data that has been read.
Blue	Indicates data that has been written
Green	Indicates data that has been both read and written.

Note: Data coverage is not supported by all C-SPY drivers. Data coverage is supported by the C-SPY Simulator.

Context menu

This context menu is available:

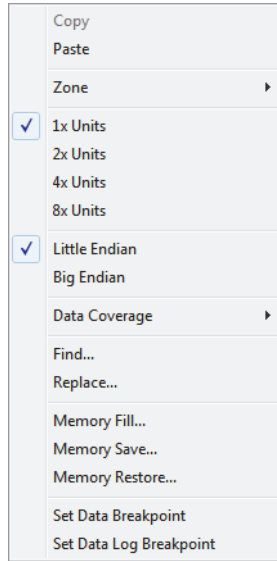

These commands are available:

Copy

Paste

Standard editing commands.

Zone

Selects a memory zone, see *C-SPY memory zones*, page 142.

1x Units

Displays the memory contents as single bytes.

2x Units

Displays the memory contents as 2-byte groups.

4x Units

Displays the memory contents as 4-byte groups.

8x Units

Displays the memory contents as 8-byte groups.

Little Endian

Displays the contents in little-endian byte order.

Big Endian

Displays the contents in big-endian byte order.

Data Coverage

Choose between:

Enable toggles data coverage on or off.

Show toggles between showing or hiding data coverage.

Clear clears all data coverage information.

These commands are only available if your C-SPY driver supports data coverage.

Find

Displays a dialog box where you can search for text within the **Memory** window; read about the **Find** dialog box in the *IDE Project Management and Building Guide for MSP430*.

Replace

Displays a dialog box where you can search for a specified string and replace each occurrence with another string; read about the **Replace** dialog box in the *IDE Project Management and Building Guide for MSP430*.

Memory Fill

Displays a dialog box, where you can fill a specified area with a value, see *Fill dialog box*, page 155.

Memory Save

Displays a dialog box, where you can save the contents of a specified memory area to a file, see *Memory Save dialog box*, page 153.

Memory Restore

Displays a dialog box, where you can load the contents of a file in Intel-hex or Motorola s-record format to a specified memory zone, see *Memory Restore dialog box*, page 154.

Set Data Breakpoint

Sets breakpoints directly in the **Memory** window. The breakpoint is not highlighted; you can see, edit, and remove it in the breakpoint dialog box. The breakpoints you set in this window will be triggered for both read and write access. For more information, see *Setting a data breakpoint in the Memory window*, page 115.

Set Data Log Breakpoint

Sets a breakpoint on the start address of a memory selection directly in the **Memory** window. The breakpoint is not highlighted; you can see, edit, and remove it in the breakpoint dialog box. The breakpoints you set in this window will be triggered by both read and write accesses; to change this, use the **Breakpoints** window. For more information, see *Data Log breakpoints*, page 109 and *Getting started using data logging*, page 200.

Memory Save dialog box

The **Memory Save** dialog box is available by choosing **Debug>Memory>Save** or from the context menu in the **Memory** window.

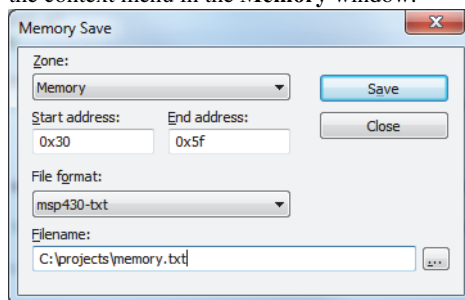

Use this dialog box to save the contents of a specified memory area to a file.

Requirements

Can be used with all C-SPY debugger drivers and debug probes.

Zone

Selects a memory zone, see *C-SPY memory zones*, page 142.

Start address

Specify the start address of the memory range to be saved.

End address

Specify the end address of the memory range to be saved.

File format

Selects the file format to be used, which is msp430-txt by default.

Filename

Specify the destination file to be used. A browse button is available.

Save

Saves the selected range of the memory zone to the specified file.

Memory Restore dialog box

The **Memory Restore** dialog box is available by choosing **Debug>Memory>Restore** or from the context menu in the **Memory** window.

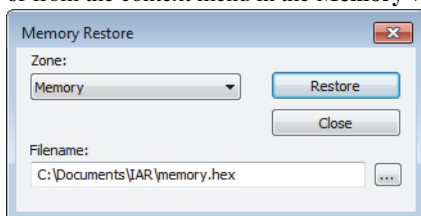

Use this dialog box to load the contents of a file in Intel-extended, Motorola S-record, or TI msp430-txt format to a specified memory zone.

Requirements

Can be used with all C-SPY debugger drivers and debug probes.

Zone

Selects a memory zone, see *C-SPY memory zones*, page 142.

Filename

Specify the file to be read. A browse button is available.

Restore

Loads the contents of the specified file to the selected memory zone.

Fill dialog box

The **Fill** dialog box is available from the context menu in the **Memory** window.

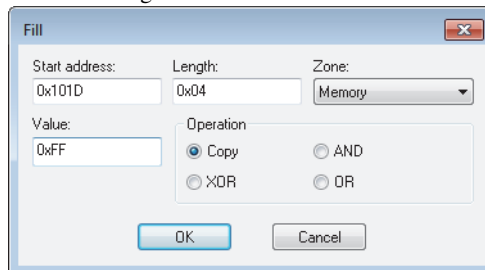

Use this dialog box to fill a specified area of memory with a value.

Requirements

Can be used with all C-SPY debugger drivers and debug probes.

Start address

Type the start address—in binary, octal, decimal, or hexadecimal notation.

Length

Type the length—in binary, octal, decimal, or hexadecimal notation.

Zone

Selects a memory zone, see *C-SPY memory zones*, page 142.

Value

Type the 8-bit value to be used for filling each memory location.

Operation

These are the available memory fill operations:

Copy

Value will be copied to the specified memory area.

AND

An **AND** operation will be performed between Value and the existing contents of memory before writing the result to memory.

XOR

An **XOR** operation will be performed between Value and the existing contents of memory before writing the result to memory.

OR

An OR operation will be performed between Value and the existing contents of memory before writing the result to memory.

Symbolic Memory window

The **Symbolic Memory** window is available from the **View** menu during a debug session.

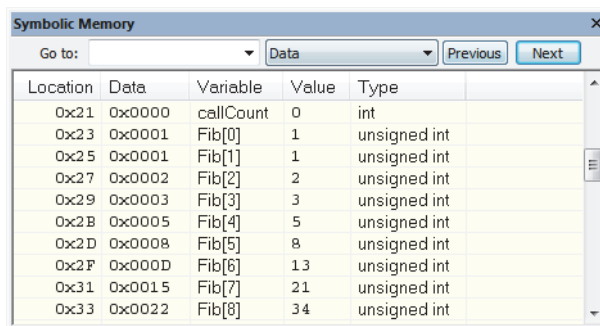

Location	Data	Variable	Value	Type
0x21	0x0000	callCount	0	int
0x23	0x0001	Fib[0]	1	unsigned int
0x25	0x0001	Fib[1]	1	unsigned int
0x27	0x0002	Fib[2]	2	unsigned int
0x29	0x0003	Fib[3]	3	unsigned int
0x2B	0x0005	Fib[4]	5	unsigned int
0x2D	0x0008	Fib[5]	8	unsigned int
0x2F	0x000D	Fib[6]	13	unsigned int
0x31	0x0015	Fib[7]	21	unsigned int
0x33	0x0022	Fib[8]	34	unsigned int

This window displays how variables with static storage duration, typically variables with file scope but also static variables in functions and classes, are laid out in memory. This can be useful for better understanding memory usage or for investigating problems caused by variables being overwritten, for example buffer overruns. Other areas of use are spotting alignment holes or for understanding problems caused by buffers being overwritten.



To view the memory corresponding to a variable, you can select it in the editor window and drag it to the **Symbolic Memory** window.

See also *Editing in C-SPY windows*, page 47.

Requirements

Can be used with all C-SPY debugger drivers and debug probes.

Toolbar

The toolbar contains:

Go to

The memory location or symbol you want to view.

Zone

Selects a memory zone, see *C-SPY memory zones*, page 142.

Previous

Highlights the previous symbol in the display area.

Next

Highlights the next symbol in the display area.

Display area

This area contains these columns:

Location

The memory address.

Data

The memory contents in hexadecimal format. The data is grouped according to the size of the symbol. This column is editable.

Variable

The variable name; requires that the variable has a fixed memory location. Local variables are not displayed.

Value

The value of the variable. This column is editable.

Type

The type of the variable.

There are several different ways to navigate within the memory space:

- Text that is dropped in the window is interpreted as symbols
- The scroll bar at the right-side of the window
- The **Next** and **Previous** toolbar buttons
- The **Go to** toolbar list box can be used for locating specific locations or symbols.

Note: Rows are marked in red when the corresponding value has changed.

Context menu

This context menu is available:

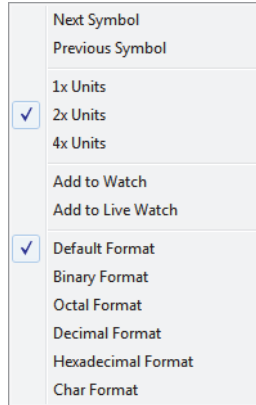

These commands are available:

Next Symbol

Highlights the next symbol in the display area.

Previous Symbol

Highlights the previous symbol in the display area.

1x Units

Displays the memory contents as single bytes. This applies only to rows that do not contain a variable.

2x Units

Displays the memory contents as 2-byte groups.

4x Units

Displays the memory contents as 4-byte groups.

Add to Watch

Adds the selected symbol to the **Watch** window.

Add to Live Watch

Adds the selected symbol to the **Live Watch** window.

Default format

Displays the memory contents in the default format.

Binary format

Displays the memory contents in binary format.

Octal format

Displays the memory contents in octal format.

Decimal format

Displays the memory contents in decimal format.

Hexadecimal format

Displays the memory contents in hexadecimal format.

Char format

Displays the memory contents in char format.

Stack window

The **Stack** window is available from the **View** menu.

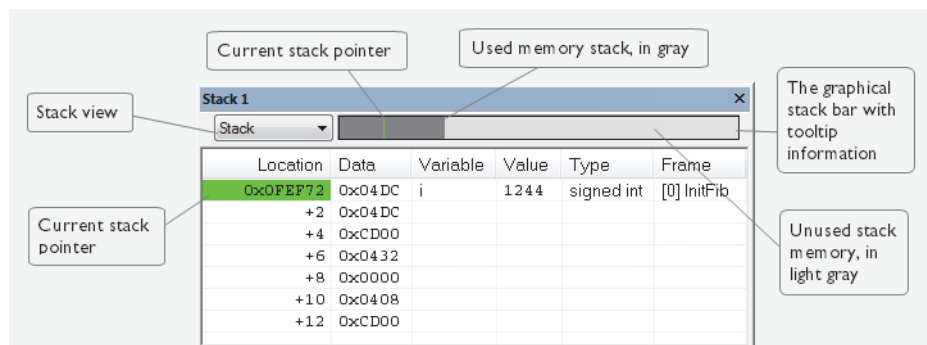

This window is a memory window that displays the contents of the stack. The graphical stack bar shows stack usage.

Note: By default, this window uses one physical breakpoint. For more information, see *Breakpoint consumers*, page 112.

For information about options specific to the **Stack** window, see the *IDE Project Management and Building Guide for MSP430*.

Requirements

Can be used with all C-SPY debugger drivers and debug probes.

Toolbar

The toolbar contains:

Stack

Selects which stack to view. This applies to microcontrollers with multiple stacks.

The graphical stack bar

Displays the state of the stack graphically.

The left end of the stack bar represents the bottom of the stack, in other words, the position of the stack pointer when the stack is empty. The right end represents the end of the memory address range reserved for the stack. The graphical stack bar turns red when the stack usage exceeds a threshold that you can specify.

To enable the stack bar, choose **Tools>Options>Stack>Enable graphical stack display and stack usage tracking**. This means that the functionality needed to detect and warn about stack overflows is enabled.



Place the mouse pointer over the stack bar to get tooltip information about stack usage.

Display area

This area contains these columns:

Location

Displays the location in memory. The addresses are displayed in increasing order. The address referenced by the stack pointer, in other words the top of the stack, is highlighted in a green color.

Data

Displays the contents of the memory unit at the given location. From the **Stack** window context menu, you can select how the data should be displayed; as a 1-, 2-, or 4-byte group of data.

Variable

Displays the name of a variable, if there is a local variable at the given location. Variables are only displayed if they are declared locally in a function, and located on the stack and not in registers.

Value

Displays the value of the variable.

Type

Displays the data type of the variable.

Frame

Displays the name of the function that the call frame corresponds to.

Context menu

This context menu is available:

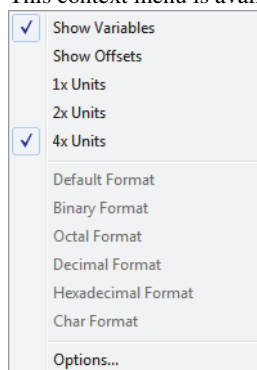

These commands are available:

Show variables

Displays separate columns named **Variables**, **Value**, and **Frame** in the **Stack** window. Variables located at memory addresses listed in the **Stack** window are displayed in these columns.

Show offsets

Displays locations in the **Location** column as offsets from the stack pointer. When deselected, locations are displayed as absolute addresses.

1x Units

Displays the memory contents as single bytes.

2x Units

Displays the memory contents as 2-byte groups.

4x Units

Displays the memory contents as 4-byte groups.

Default Format

Binary Format

Octal Format

Decimal Format

Hexadecimal Format

Char Format

Changes the display format of expressions. The display format setting affects different types of expressions in different ways. Your selection of display format is saved between debug sessions. These commands are available if a selected line in the window contains a variable.

The display format setting affects different types of expressions in these ways:

Variables	The display setting affects only the selected variable, not other variables.
Array elements	The display setting affects the complete array, that is, the same display format is used for each array element.
Structure fields	All elements with the same definition—the same field name and C declaration type—are affected by the display setting.

Options

Opens the **IDE Options** dialog box where you can set options specific to the **Stack** window, see the *IDE Project Management and Building Guide for MSP430*.

Registers window

The **Registers** windows are available from the **View** menu.

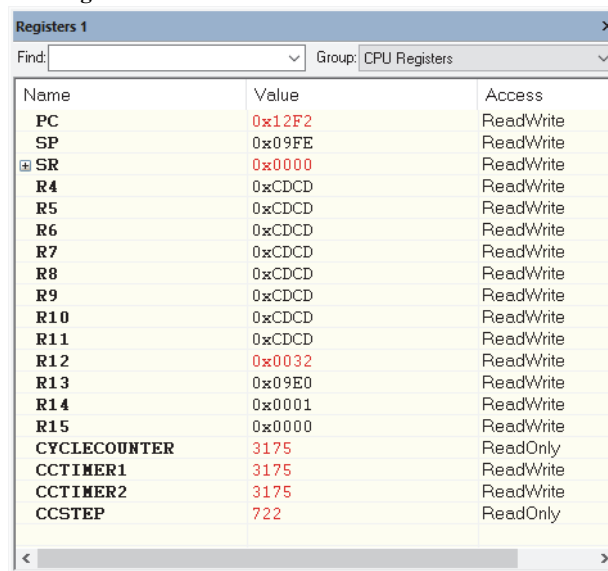

Name	Value	Access
PC	0x12F2	ReadWrite
SP	0x09FE	ReadWrite
SR	0x0000	ReadWrite
R4	0xCDCD	ReadWrite
R5	0xCDCD	ReadWrite
R6	0xCDCD	ReadWrite
R7	0xCDCD	ReadWrite
R8	0xCDCD	ReadWrite
R9	0xCDCD	ReadWrite
R10	0xCDCD	ReadWrite
R11	0xCDCD	ReadWrite
R12	0x0032	ReadWrite
R13	0x09E0	ReadWrite
R14	0x0001	ReadWrite
R15	0x0000	ReadWrite
CYCLECOUNTER	3175	ReadOnly
CCTIMER1	3175	ReadWrite
CCTIMER2	3175	ReadWrite
CCSTEP	722	ReadOnly

These windows give an up-to-date display of the contents of the processor registers and special function registers, and allow you to edit the contents of some of the registers. Optionally, you can choose to load either predefined register groups or your own user-defined groups.

You can open up to four instances of this window, which is convenient for keeping track of different register groups.

See also *Editing in C-SPY windows*, page 47.

To enable predefined register groups:

- 1 Select a device description file that suits your device, see *Selecting a device description file*, page 44. These files contain predefined register groups.
- 2 Display the registers of a register group by selecting it from the **Group** drop-down menu on the toolbar, or by right-clicking in the window and choosing **View Group** from the context menu.

For information about creating your own user-defined register groups, see *Defining application-specific register groups*, page 144.

Requirements

Can be used with all C-SPY debugger drivers and debug probes.

Toolbar

The toolbar contains:

Find

Specify the name, or part of a name, of a register (or group) that you want to find. Press the Enter key and the first matching register, or group with a matching register, is displayed. User-defined register groups are not searched. The search box preserves a history of previous searches. To repeat a search, select it from the search history and press Enter.

Group

Selects which predefined register group to display. If some of your SFRs are missing, you can register your own SFRs in a Custom group, see *SFR Setup window*, page 168. Additional predefined registers are defined in a specific register definition file—with the filename extension `sfr`—which is included from the register section of the device description file. These registers are the device-specific memory-mapped control and status registers for the peripheral units on the MSP430 microcontrollers.

Display area

Displays registers and their values. Some registers are expandable, which means that the register contains interesting bits or subgroups of bits.

If you drag a numerical value, a valid expression, or a register name from another part of the IDE to an editable value cell in a **Registers** window, the value will be changed to that of what you dragged. If you drop a register name somewhere else in the window, the window contents will change to display the first register group where this register is found.

Name

The name of the register.

Value

The current value of the register. Every time C-SPY stops, a value that has changed since the last stop is highlighted. Some of the registers are editable. To edit the contents of an editable register, click on the register and modify its value. Press Esc to cancel the change.

To change the display format of the value, right-click on the register and choose **Format** from the context menu.

Access

The access type of the register. Some of the registers are read-only, while others are write-only.

Note: When the FET Debugger is used, the cycle counter registers can only be used while single-stepping in the **Disassembly** window.

For the C-SPY Simulator (and some C-SPY hardware debugger drivers), these additional support registers are available in the CPU Registers group:

CYCLECOUNTER	Cleared when an application is started or reset, and is incremented with the number of used cycles during execution.
CCSTEP	Shows the number of used cycles during the last performed C/C++ source or assembler step.
CCTIMER1 and CCTIMER2	Two <i>trip counts</i> that can be cleared manually at any given time. They are incremented with the number of used cycles during execution.

Context menu

This context menu is available:

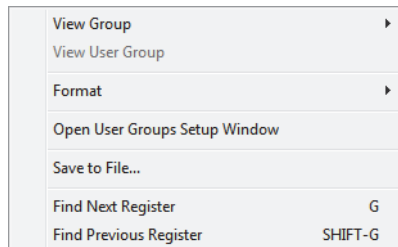

These commands are available:

View Group

Selects which predefined register group to display.

View User Group

Selects which user-defined register group to display. For information about creating your own user-defined register groups, see *Defining application-specific register groups*, page 144.

Format

Changes the display format for the contents of the register you clicked on. The display format setting affects different types of registers in different ways. Your selection of display format is saved between debug sessions.

Open User Groups Setup Window

Opens a window where you can create your own user-defined register groups, see *Register User Groups Setup window*, page 166.

Save to File

Opens a standard **Save** dialog box to save the contents of the window to a tab-separated text file.

Find Next Register

Finds the predefined register or register group that comes immediately after what your search found. After the last register was found, this search wraps around and finds the first register again.

Find Previous Register

Finds the matching predefined register or register group that comes immediately before what your search found. After the first register was found, this search wraps around and finds the last register again.

Register User Groups Setup window

The **Register User Groups Setup** window is available from the **View** menu or from the context menu in the **Registers** windows.

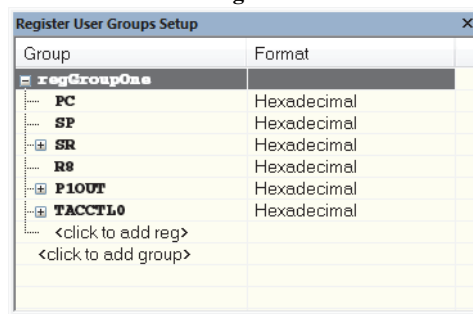

Use this window to define your own application-specific register groups. These register groups can then be viewed in the **Registers** windows.

Defining application-specific register groups means that the **Registers** windows can display just those registers that you need to watch for your current debugging task. This makes debugging much easier.

Requirements

Can be used with all C-SPY debugger drivers and debug probes.

Display area

This area contains these columns:

Group

The names of register groups and the registers they contain. Clicking on <click to add group> or <click to add reg> and typing the name of a register group or register, adds new groups and registers, respectively. You can also drag a register name from another window in the IDE. Click a name to change it.

A dimmed register name indicates that it is not supported by the selected device.

Format

Shows the display format for the register's value. To change the display format of the value, right-click on the register and choose **Format** from the context menu. The selected format is used in all **Registers** windows.

Context menu

This context menu is available:

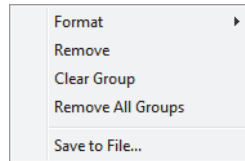

These commands are available:

Format

Changes the display format for the contents of the register you clicked on. The display format setting affects different types of registers in different ways. Your selection of display format is saved between debug sessions.

Remove

Removes the register or group you clicked on.

Clear Group

Removes all registers from the group you clicked on.

Remove All Groups

Deletes all user-defined register groups from your project.

Save to File

Opens a standard **Save** dialog box to save the contents of the window to a tab-separated text file.

SFR Setup window

The **SFR Setup** window is available from the **Project** menu.

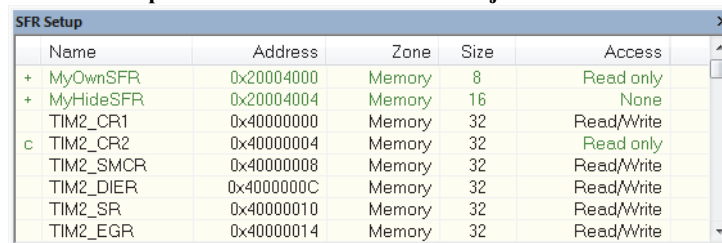

Name	Address	Zone	Size	Access
+ MyOwnSFR	0x20004000	Memory	8	Read only
+ MyHideSFR	0x20004004	Memory	16	None
TIM2_CR1	0x40000000	Memory	32	Read/Write
c TIM2_CR2	0x40000004	Memory	32	Read only
TIM2_SMCR	0x40000008	Memory	32	Read/Write
TIM2_DIER	0x4000000C	Memory	32	Read/Write
TIM2_SR	0x40000010	Memory	32	Read/Write
TIM2_EGR	0x40000014	Memory	32	Read/Write

This window displays the currently defined SFRs that C-SPY has information about. You can choose to display only factory-defined or custom-defined SFRs, or both. If required, you can use the **Edit SFR** dialog box to customize the SFR definitions, see *Edit SFR dialog box*, page 171. For factory-defined SFRs (that is, retrieved from the `adf` file in use), you can only customize the access type.

To quickly find an SFR, drag a text or hexadecimal number string and drop in this window. If what you drop starts with a 0 (zero), the **Address** column is searched, otherwise the **Name** column is searched.

Any custom-defined SFRs are added to a dedicated register group called Custom, which you can choose to display in the **Registers** window. Your custom-defined SFRs are saved in `projectCustomSFR.sfr`. This file is automatically loaded in the IDE when you start C-SPY with a project whose name matches the prefix of the filename of the `sfr` file.

You can only add or modify SFRs when the C-SPY debugger is not running.

Requirements

Can be used with all C-SPY debugger drivers and debug probes.

Display area

This area contains these columns:

Status

A character that signals the status of the SFR, which can be one of:
blank, a factory-defined SFR.

C, a factory-defined SFR that has been modified.

+, a custom-defined SFR.

?, an SFR that is ignored for some reason. An SFR can be ignored when a factory-defined SFR has been modified, but the SFR is no longer available, or it is located somewhere else or with a different size. Typically, this might happen if you change to another device.

Name

A unique name of the SFR.

Address

The memory address of the SFR.

Zone

Selects a memory zone, see *C-SPY memory zones*, page 142.

Size

The size of the register, which can be any of **8**, **16**, **32**, or **64**.

Access

The access type of the register, which can be one of **Read/Write**, **Read only**, **Write only**, or **None**.

You can click a name or an address to change the value. The hexadecimal 0x prefix for the address can be omitted, the value you enter will still be interpreted as hexadecimal. For example, if you enter 4567, you will get 0x4567.

You can click a column header to sort the SFRs according to the column property.

Color coding used in the display area:

- Green, which indicates that the corresponding value has changed
- Red, which indicates an ignored SFR.

Context menu

This context menu is available:

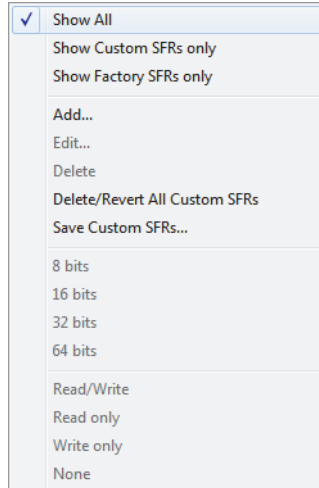

These commands are available:

Show All

Shows all SFR.

Show Custom SFRs only

Shows all custom-defined SFRs.

Show Factory SFRs only

Shows all factory-defined SFRs retrieved from the ddf file.

Add

Displays the **Edit SFR** dialog box where you can add a new SFR, see *Edit SFR dialog box*, page 171.

Edit

Displays the **Edit SFR** dialog box where you can edit an SFR, see *Edit SFR dialog box*, page 171.

Delete

Deletes an SFR. This command only works on custom-defined SFRs.

Delete/revert All Custom SFRs

Deletes all custom-defined SFRs and reverts all modified factory-defined SFRs to their factory settings.

Save Custom SFRs

Opens a standard **Save** dialog box to save all custom-defined SFRs.

8|16|32|64 bits

Selects display format for the selected SFR, which can be **8**, **16**, **32**, or **64** bits. Note that the display format can only be changed for custom-defined SFRs.

Read/Write|Read only|Write only|None

Selects the access type of the selected SFR, which can be **Read/Write**, **Read only**, **Write only**, or **None**. Note that for factory-defined SFRs, the default access type is indicated.

Edit SFR dialog box

The **Edit SFR** dialog box is available from the context menu in the **SFR Setup** window.

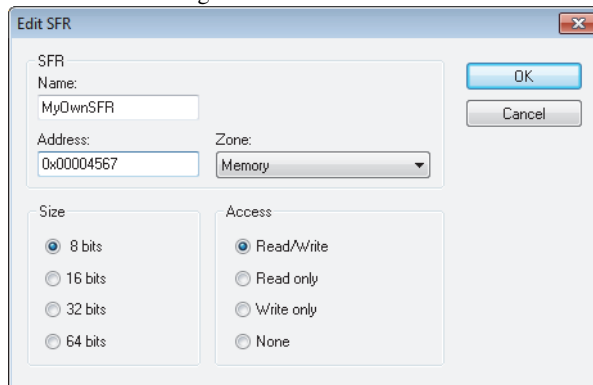

Definitions of the SFRs are retrieved from the device description file in use. Use this dialog box to either modify these factory-defined definitions or define new SFRs. See also *SFR Setup window*, page 168.

Requirements

Can be used with all C-SPY debugger drivers and debug probes.

Name

Specify the name of the SFR that you want to add or edit.

Address

Specify the address of the SFR that you want to add or edit. The hexadecimal 0x prefix for the address can be omitted, the value you enter will still be interpreted as hexadecimal. For example, if you enter 4567, you will get 0x4567.

Zone

Selects the memory zone for the SFR you want to add or edit. The list of zones is retrieved from the `adf` file that is currently used.

Size

Selects the size of the SFR. Choose between **8**, **16**, **32**, or **64** bits. Note that the display format can only be changed for custom-defined SFRs.

Access

Selects the access type of the SFR. Choose between **Read/Write**, **Read only**, **Write only**, or **None**. Note that for factory-defined SFRs, the default access type is indicated.

Memory Access Setup dialog box

The **Memory Access Setup** dialog box is available from the C-SPY driver menu.

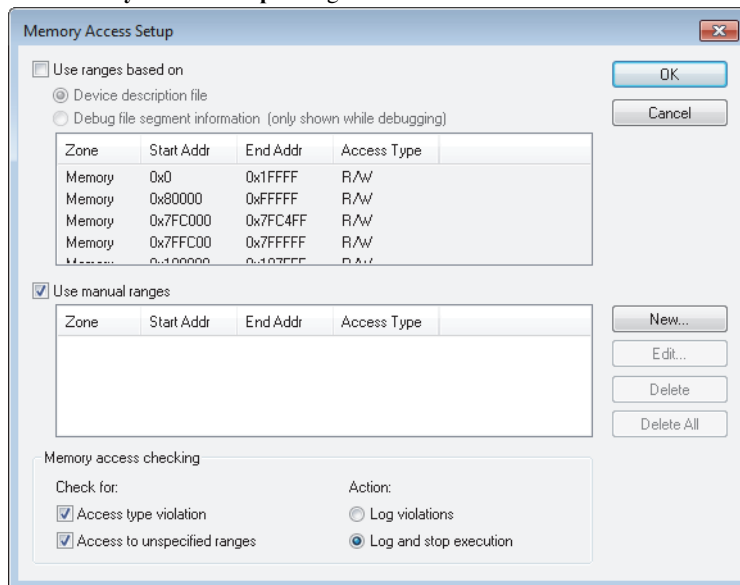

Use this dialog box to specify which set of memory address ranges to be used by C-SPY during debugging.

Note: If you enable both the **Use ranges based on** and the **Use manual ranges** option, memory accesses are checked for all defined ranges.

For information about the columns and the properties displayed, see *Edit Memory Access dialog box*, page 175. See also *Memory configuration for the C-SPY simulator*, page 143.

Requirements

The C-SPY simulator.

Use ranges based on

Specify if the memory configuration should be retrieved from a predefined configuration. Choose between:

Device description file

Retrieves the memory configuration from the device description file that you have specified. See *Selecting a device description file*, page 44.

This option is used by default.

Debug file segment information

Retrieves the memory configuration from the debug file, which has retrieved it from the linker configuration file. This information is only available during a debug session. The advantage of using this option is that the simulator can catch memory accesses outside the linked application.

Use manual ranges

Specify your own ranges manually via the **Edit Memory Access** dialog box. To open this dialog box, click **New** to specify a new memory address range, or select an existing memory address range and choose **Edit** to modify it. For more information, see *Edit Memory Access dialog box*, page 175.

The ranges you define manually are saved between debug sessions.

Memory access checking

Check for determines what to check for:

- **Access type violation**
- **Access to unspecified ranges**

Action selects the action to be performed if an access violation occurs. Choose between:

- **Log violations**
- **Log and stop execution**

Any violations are logged in the **Debug Log** window.

Buttons

These buttons are available for manual ranges:

New

Opens the **Edit Memory Access** dialog box, where you can specify a new memory address range and associate an access type with it, see *Edit Memory Access dialog box*, page 175.

Edit

Opens the **Edit Memory Access** dialog box, where you can edit the selected memory address range. See *Edit Memory Access dialog box*, page 175.

Delete

Deletes the selected memory address range definition.

Delete All

Deletes all defined memory address range definitions.

Edit Memory Access dialog box

The **Edit Memory Access** dialog box is available from the **Memory Access Setup** dialog box.

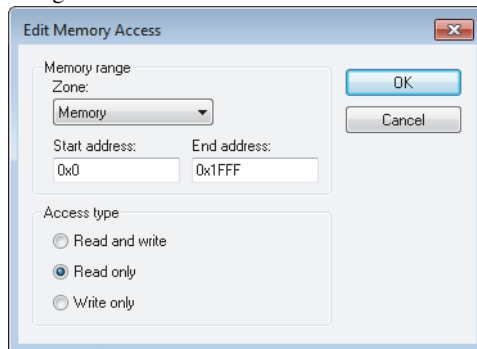

Use this dialog box to specify your memory address ranges for which you want to detect illegal accesses during the simulation, and assign an access type to each range.

Requirements

The C-SPY simulator.

Memory range

Defines the memory address range specific to your device:

Zone

Selects a memory zone, see *C-SPY memory zones*, page 142.

Start address

Specify the start address for the memory address range, in hexadecimal notation.

End address

Specify the end address for the memory address range, in hexadecimal notation.

Access type

Selects an access type to the memory address range. Choose between:

- **Read and write**

- **Read only**
- **Write only.**

Memory Dump dialog box

The **Memory Dump** dialog box is available from the **Emulator** menu.

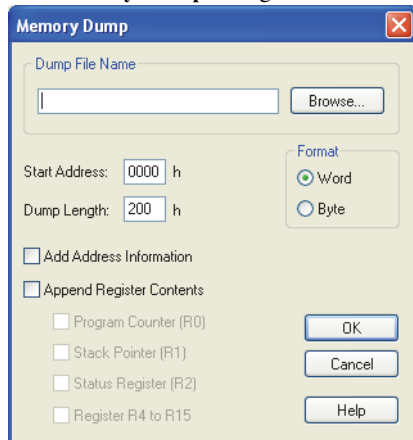

Use this dialog box to write memory contents to a file.

Requirements

The C-SPY FET Debugger driver.

Dump File Name

Specify the name of the destination file where the contents of the selected part of the memory will be saved in text format. You can find the file using the **Browse** button.

Start Address

Specify the start address for the memory section you want to save to a file.

Dump Length

Specify the length of the memory section you want to save to a file, in hexadecimal notation. The maximum length is FFFF, which limits the number of bytes that can be written to 65535. Consequently, you cannot write memory from address 0x0000 to 0xFFFF, inclusive, as this would require a length specifier of 65536 bytes (0x10000).

Add address information

Adds address information to the file.

Append register contents

Appends register contents to the file. Choose between:

Program Counter (R0)

Stack Pointer (R1)

Status Register (R2)

Register R4 to R15

Format

Selects format for the text that is written to the file. Choose between:

Word

Byte

Part 2. Analyzing your application

This part of the *C-SPY® Debugging Guide for MSP430* includes these chapters:

- Trace
- The application timeline
- Profiling
- Code coverage
- Power debugging

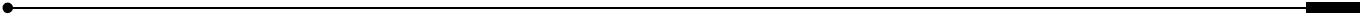
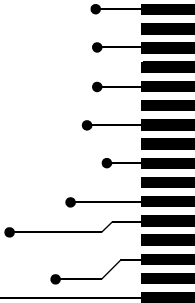

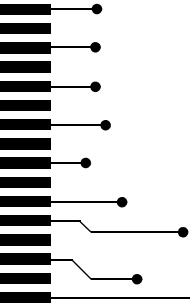

Trace

- Introduction to using trace
- Collecting and using trace data
- Reference information on trace

Introduction to using trace

These topics are covered:

- Reasons for using trace
- Briefly about trace
- Requirements for using trace

See also:

- *Getting started using data logging*, page 200
- *Power debugging*, page 241
- *Getting started using interrupt logging*, page 274
- *Profiling*, page 225
- *Using state storage*, page 300

REASONS FOR USING TRACE

By using trace, you can inspect the program flow up to a specific state, for instance an application crash, and use the trace data to locate the origin of the problem. Trace data can be useful for locating programming errors that have irregular symptoms and occur sporadically.

BRIEFLY ABOUT TRACE

To use trace in C-SPY requires that your target system can generate trace data. Once generated, C-SPY can collect it and you can visualize and analyze the data in various windows and dialog boxes.

Trace data is a continuously collected sequence of every executed instruction for a selected portion of the execution.

Trace features in C-SPY

In C-SPY, you can use the trace-related windows—**Trace**, **Function Trace**, **Timeline**, and **Find in Trace**.

Depending on your C-SPY driver, you:

- Can set various types of trace breakpoints to control the collection of trace data.
- Have access to windows such as the **Interrupt Log**, **Interrupt Log Summary**, **Data Log**, and **Data Log Summary**.

In addition, several other features in C-SPY also use trace data, features such as Profiling, Code coverage, and Instruction profiling.

REQUIREMENTS FOR USING TRACE

The C-SPY simulator supports trace-related functionality, and there are no specific requirements.

Trace data cannot be collected from the hardware debugger systems.

Collecting and using trace data

These tasks are covered:

- Getting started with trace
- Trace data collection using breakpoints
- Searching in trace data
- Browsing through trace data

GETTING STARTED WITH TRACE



- 1 After you have built your application and started C-SPY, open the **Trace** window—available from the driver-specific menu—and click the **Activate** button to enable collecting trace data.
- 2 Start the execution. When the execution stops, for example because a breakpoint is triggered, trace data is displayed in the **Trace** window. For more information about the window, see *Trace window*, page 184.

TRACE DATA COLLECTION USING BREAKPOINTS

A convenient way to collect trace data between two execution points is to start and stop the data collection using dedicated breakpoints.

Choose between these alternatives:

- In the editor or **Disassembly** window, position your insertion point, right-click, and toggle a **Trace Start Trigger** or **Trace Stop Trigger** breakpoint from the context menu.
- In the **Breakpoints** window, choose **New Breakpoint>Trace Start Trigger** or **Trace Stop Trigger** from the context menu.
- The C-SPY system macros `__setTraceStartBreak` and `__setTraceStopBreak` can also be used.

For more information about these breakpoints, see *Trace Start Trigger breakpoint dialog box*, page 189 and *Trace Stop Trigger breakpoint dialog box*, page 190, respectively.

SEARCHING IN TRACE DATA

When you have collected trace data, you can perform searches in the collected data to locate the parts of your code or data that you are interested in, for example, a specific interrupt or accesses of a specific variable.

You specify the search criteria in the **Find in Trace** dialog box and view the result in the **Find in Trace** window.

The **Find in Trace** window is very similar to the **Trace** window, showing the same columns and data, but *only* those rows that match the specified search criteria.

Double-clicking an item in the **Find in Trace** window brings up the same item in the **Trace** window.

To search in your trace data:



- 1 On the **Trace** window toolbar, click the **Find** button.
- 2 In the **Find in Trace** dialog box, specify your search criteria.

Typically, you can choose to search for:

- A specific piece of text, for which you can apply further search criteria
- An address range
- A combination of these, like a specific piece of text within a specific address range.

For more information about the various options, see *Find in Trace dialog box*, page 193.

- 3 When you have specified your search criteria, click **Find**. The **Find in Trace** window is displayed, which means you can start analyzing the trace data. For more information, see *Find in Trace window*, page 194.

BROWSING THROUGH TRACE DATA

To follow the execution history, simply look and scroll in the **Trace** window. Alternatively, you can enter *browse mode*.



To enter browse mode, double-click an item in the **Trace** window, or click the **Browse** toolbar button.

The selected item turns yellow and the source and **Disassembly** windows will highlight the corresponding location. You can now move around in the trace data using the up and down arrow keys, or by scrolling and clicking; the source and **Disassembly** windows will be updated to show the corresponding location. This is like stepping backward and forward through the execution history.

Double-click again to leave browse mode.

Reference information on trace

Reference information about:

- *Trace window*, page 184
- *Function Trace window*, page 188
- *Trace Start Trigger breakpoint dialog box*, page 189
- *Trace Stop Trigger breakpoint dialog box*, page 190
- *Trace Expressions window*, page 191
- *Find in Trace dialog box*, page 193
- *Find in Trace window*, page 194

Trace window

The **Trace** window is available from the C-SPY driver menu.

This window displays the collected trace data.

See also *Collecting and using trace data*, page 182.

Requirements

The C-SPY simulator.

Trace toolbar

The toolbar in the **Trace** window and in the **Function Trace** window contains:



Enable/Disable

Enables and disables collecting and viewing trace data in this window. This button is not available in the **Function Trace** window.



Clear trace data

Clears the trace buffer. Both the **Trace** window and the **Function Trace** window are cleared.



Toggle source

Toggles the **Trace** column between showing only disassembly or disassembly together with the corresponding source code.



Browse

Toggles browse mode on or off for a selected item in the **Trace** window.



Find

Displays a dialog box where you can perform a search, see *Find in Trace dialog box*, page 193.



Save

Displays a standard **Save As** dialog box where you can save the collected trace data to a text file, with tab-separated columns.



Edit Settings

In the C-SPY simulator, this button is not enabled.

Edit Expressions (C-SPY simulator only)



Opens the **Trace Expressions** window, see *Trace Expressions window*, page 191.

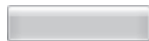

Progress bar

When a large amount of trace data has been collected, there might be a delay before all of it has been processed and can be displayed. The progress bar reflects that processing.

Display area

This area displays a collected sequence of executed machine instructions. In addition, the window can display trace data for expressions.

#	Cycles	Trace	callCount
1396	2766	FFF80574 MOV.L SP, R2	10
1397	2767	FFF80576 MOV #0x01:4, R1	10
1398	2771	FFF80578 BSR.A __DebugBreak	10
		__DebugBreak:	
1399	2777	FFF804E0 RTS	10
1400	2780	FFF8057C BRA.B 0xFFF80572	10
1401	2781	FFF80572 MOV.L R6, [SP]	10
1402	2782	FFF80574 MOV.L SP, R2	10
1403	2783	FFF80576 MOV #0x01:4, R1	10

This area contains these columns for the C-SPY simulator:

#

A serial number for each row in the trace buffer. Simplifies the navigation within the buffer.

Cycles

The number of cycles elapsed to this point.

Trace

The collected sequence of executed machine instructions. Optionally, the corresponding source code can also be displayed.

Expression

Each expression you have defined to be displayed appears in a separate column. Each entry in the expression column displays the value *after* executing the instruction on the same row. You specify the expressions for which you want to collect trace data in the **Trace Expressions** window, see *Trace Expressions window*, page 191.

A red-colored row indicates that the previous row and the red row are not consecutive. This means that there is a gap in the collected trace data, for example because trace data has been lost due to an overflow.

Context menu

This context menu is available:

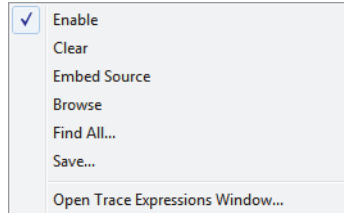

Note: The contents of this menu are dynamic and depend on which features that your combination of software and hardware supports. However, the list of menu commands below is complete and covers all possible commands.

These commands are available:

Enable

Enables and disables collecting and viewing trace data in this window.

Clear

Clears the trace buffer. Both the **Trace** window and the **Function Trace** window are cleared.

Embed source

Toggles the **Trace** column between showing only disassembly or disassembly together with the corresponding source code.

Browse

Toggles browse mode on or off for a selected item in the **Trace** window.

Find All

Displays a dialog box where you can perform a search in the **Trace** window, see *Find in Trace dialog box*, page 193. The search results are displayed in the **Find in Trace** window—available by choosing the **View>Messages** command, see *Find in Trace window*, page 194.

Save

Displays a standard **Save As** dialog box where you can save the collected trace data to a text file, with tab-separated columns.

Open Trace Expressions Window

Opens the **Trace Expressions** window, see *Trace Expressions window*, page 191.

Function Trace window

The **Function Trace** window is available from the C-SPY driver menu during a debug session.

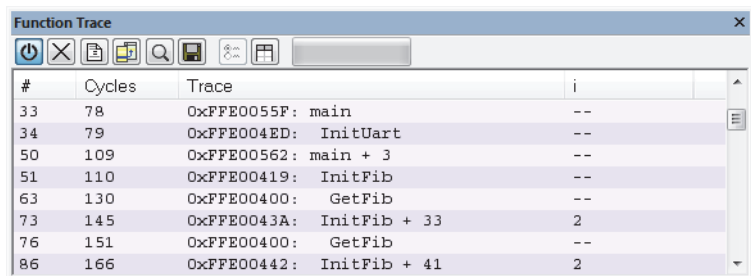

#	Cycles	Trace	i
33	78	0xFFE0055F: main	--
34	79	0xFFE004ED: InitUart	--
50	109	0xFFE00562: main + 3	--
51	110	0xFFE00419: InitFib	--
63	130	0xFFE00400: GetFib	--
73	145	0xFFE0043A: InitFib + 33	2
76	151	0xFFE00400: GetFib	--
86	166	0xFFE00442: InitFib + 41	2

This window displays a subset of the trace data displayed in the **Trace** window. Instead of displaying all rows, the **Function Trace** window shows:

- The functions called or returned to, instead of the traced instruction
- The corresponding trace data.

Requirements

The C-SPY simulator.

Toolbar

For information about the toolbar, see *Trace window*, page 184.

Display area

There are two sets of columns available, and which set is used in your debugging system depends on the debug probe and which trace sources that are available:

- The available columns are the same as in the **Trace** window, see *Trace window*, page 184.
- For debugProbe1 and debugProbe2 and depending on the trace source, these columns are available:

Cycles

The number of cycles elapsed to this point according to the timestamp in the debug probe.

Address

The address of the executed instruction.

Call/Return

The function that was called or returned to.

Trace Start Trigger breakpoint dialog box

The **Trace Start Trigger** dialog box is available from the context menu that appears when you right-click in the **Breakpoints** window.

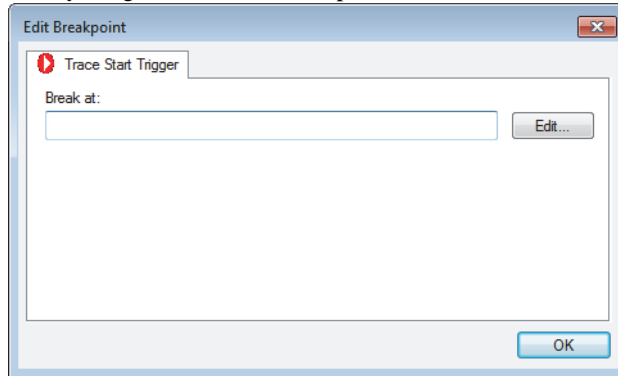

Use this dialog box to set a Trace Start Trigger breakpoint where you want to start collecting trace data. If you want to collect trace data only for a specific range, you must also set a Trace Stop Trigger breakpoint where you want to stop collecting data.

See also *Trace Stop Trigger breakpoint dialog box*, page 190 and *Trace data collection using breakpoints*, page 183.

To set a Trace Start Trigger breakpoint:

- 1 In the editor or **Disassembly** window, right-click and choose **Trace Start Trigger** from the context menu.

Alternatively, open the **Breakpoints** window by choosing **View>Breakpoints**.

- 2 In the **Breakpoints** window, right-click and choose **New Breakpoint>Trace Start Trigger**.

Alternatively, to modify an existing breakpoint, select a breakpoint in the **Breakpoints** window and choose **Edit** on the context menu.

- 3 In the **Break at** text box, specify an expression, an absolute address, or a source location. Click **OK**.
- 4 When the breakpoint is triggered, the trace data collection starts.

Requirements

The C-SPY simulator.

Trigger at

Specify the code location of the breakpoint. Alternatively, click the **Edit** button to open the **Enter Location** dialog box, see *Enter Location dialog box*, page 136.

Trace Stop Trigger breakpoint dialog box

The **Trace Stop Trigger** dialog box is available from the context menu that appears when you right-click in the **Breakpoints** window.

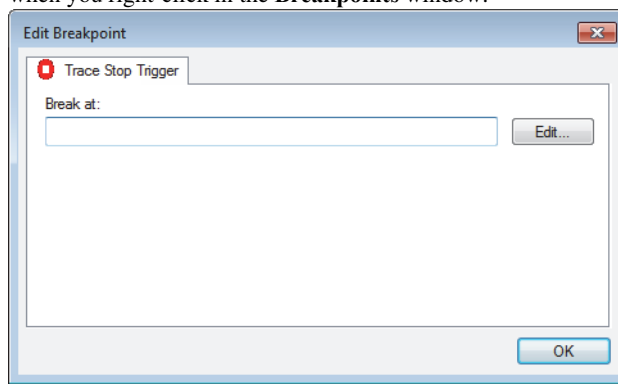

Use this dialog box to set a Trace Stop Trigger breakpoint where you want to stop collecting trace data. If you want to collect trace data only for a specific range, you might also need to set a Trace Start Trigger breakpoint where you want to start collecting data.

See also *Trace Start Trigger breakpoint dialog box*, page 189 and *Trace data collection using breakpoints*, page 183.

To set a Trace Stop Trigger breakpoint:

- 1** In the editor or **Disassembly** window, right-click and choose **Trace Stop Trigger** from the context menu.

Alternatively, open the **Breakpoints** window by choosing **View>Breakpoints**.

- 2** In the **Breakpoints** window, right-click and choose **New Breakpoint>Trace Stop Trigger**.

Alternatively, to modify an existing breakpoint, select a breakpoint in the **Breakpoints** window and choose **Edit** on the context menu.

- 3** In the **Break at** text box, specify an expression, an absolute address, or a source location. Click **OK**.
- 4** When the breakpoint is triggered, the trace data collection stops.

Requirements

The C-SPY simulator.

Trigger at

Specify the code location of the breakpoint. Alternatively, click the **Edit** button to open the **Enter Location** dialog box, see *Enter Location dialog box*, page 136.

Trace Expressions window

The **Trace Expressions** window is available from the **Trace** window toolbar.

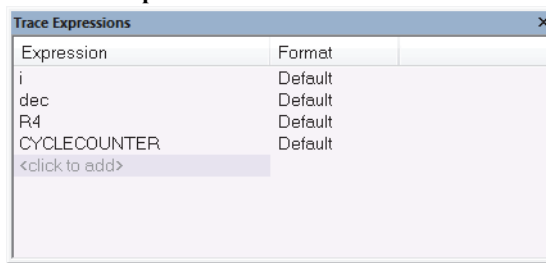

Use this window to specify, for example, a specific variable (or an expression) for which you want to collect trace data.

Requirements

The C-SPY simulator.

Display area

Use the display area to specify expressions for which you want to collect trace data:

Expression

Specify any expression that you want to collect data from. You can specify any expression that can be evaluated, such as variables and registers.

Format

Shows which display format that is used for each expression. Note that you can change display format via the context menu.

Each row in this area will appear as an extra column in the **Trace** window.

Context menu

This context menu is available:

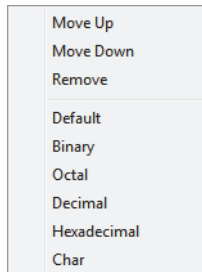

These commands are available:

Move Up

Moves the selected expression upward in the window.

Move Down

Moves the selected expression downward in the window.

Remove

Removes the selected expression from the window.

Default Format

Binary Format

Octal Format

Decimal Format

Hexadecimal Format

Char Format

Changes the display format of expressions. The display format setting affects different types of expressions in different ways. Your selection of display format is saved between debug sessions. These commands are available if a selected line in the window contains a variable.

The display format setting affects different types of expressions in these ways:

Variables	The display setting affects only the selected variable, not other variables.
Array elements	The display setting affects the complete array, that is, the same display format is used for each array element.
Structure fields	All elements with the same definition—the same field name and C declaration type—are affected by the display setting.

Find in Trace dialog box

The **Find in Trace** dialog box is available by clicking the **Find** button on the **Trace** window toolbar or by choosing **Edit>Find and Replace>Find**.

Note that the **Edit>Find and Replace>Find** command is context-dependent. It displays the **Find in Trace** dialog box if the **Trace** window is the current window or the **Find** dialog box if the editor window is the current window.

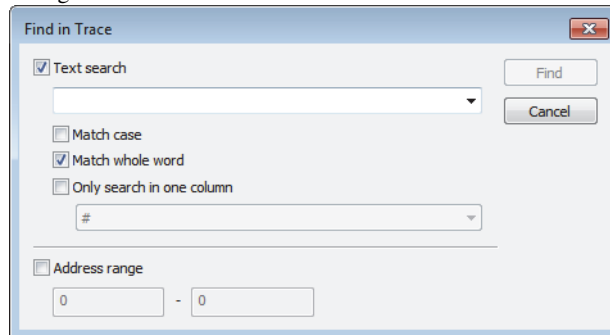

Use this dialog box to specify the search criteria for advanced searches in the trace data.

The search results are displayed in the **Find in Trace** window—available by choosing the **View>Messages** command, see *Find in Trace window*, page 194.

See also *Searching in trace data*, page 183.

Requirements

The C-SPY simulator.

Text search

Specify the string you want to search for. To specify the search criteria, choose between:

Match case

Searches only for occurrences that exactly match the case of the specified text. Otherwise **int** will also find **INT**, **Int**, and so on.

Match whole word

Searches only for the string when it occurs as a separate word. Otherwise **int** will also find **print**, **sprintf**, and so on.

Only search in one column

Searches only in the column you selected from the drop-down list.

Address range

Specify the address range you want to display or search. The trace data within the address range is displayed. If you have also specified a text string in the **Text search** field, the text string is searched for within the address range.

Find in Trace window

The **Find in Trace** window is available from the **View>Messages** menu. Alternatively, it is automatically displayed when you perform a search using the **Find in Trace** dialog box or perform a search using the **Find in Trace** command available from the context menu in the editor window.

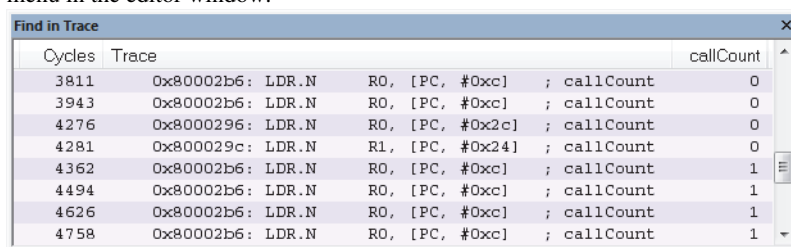

Cycles	Trace	callCount
3811	0x80002b6: LDR.N RO, [PC, #0xc] ; callCount	0
3943	0x80002b6: LDR.N RO, [PC, #0xc] ; callCount	0
4276	0x8000296: LDR.N RO, [PC, #0x2c] ; callCount	0
4281	0x800029c: LDR.N R1, [PC, #0x24] ; callCount	0
4362	0x80002b6: LDR.N RO, [PC, #0xc] ; callCount	1
4494	0x80002b6: LDR.N RO, [PC, #0xc] ; callCount	1
4626	0x80002b6: LDR.N RO, [PC, #0xc] ; callCount	1
4758	0x80002b6: LDR.N RO, [PC, #0xc] ; callCount	1

This window displays the result of searches in the trace data. Double-click an item in the **Find in Trace** window to bring up the same item in the **Trace** window.

Before you can view any trace data, you must specify the search criteria in the **Find in Trace** dialog box, see *Find in Trace dialog box*, page 193.

See also *Searching in trace data*, page 183.

Requirements

The C-SPY simulator.

Display area

The **Find in Trace** window looks like the **Trace** window and shows the same columns and data, but *only* those rows that match the specified search criteria.

The application timeline

- Introduction to analyzing your application's timeline
- Analyzing your application's timeline
- Reference information on application timeline

Introduction to analyzing your application's timeline

These topics are covered:

- Briefly about analyzing the timeline
- Requirements for timeline support

See also:

- *Trace*, page 181

BRIEFLY ABOUT ANALYZING THE TIMELINE

C-SPY can provide information for various aspects of your application, collected when the application is running. This can help you to analyze the application's behavior.

You can view the timeline information in different representations:

- As different *graphs* that correlate with the running application in relation to a shared *time axis*.
- As detailed logs
- As summaries of the logs.

Depending on the capabilities of your hardware, the debug probe, and the C-SPY driver you are using, timeline information can be provided for:

Call stack Can be represented in the **Timeline** window, as a graph that displays the sequence of function calls and returns collected by the trace system. You get timing information between the function invocations.

Note that there is also a related **Call Stack** window and a **Function Trace** window, see *Call Stack window*, page 71 and *Function Trace window*, page 188, respectively.

Data logging Based on data logs collected by the trace system for up to four different variables or address ranges, specified by means of *Data Log breakpoints*. Choose to display the data logs:

- In the **Timeline** window, as a graph of how the values change over time.
- In the **Data Log** window and the **Data Log Summary** window.

Interrupt logging Based on interrupt logs collected by the trace system. Choose to display the interrupt logs:

- In the **Timeline** window, as a graph of the interrupt events during the execution of your application.
- In the **Interrupt Log** window and the **Interrupt Log Summary** window.

Interrupt logging can, for example, help you locate which interrupts you can fine-tune to make your application more efficient.

For more information, see the chapter *Interrupts*.

Power logging Based on logged power measurement samples generated by the debug probe or associated hardware. Choose to display the power logs:

- In the **Timeline** window, as a graph of the power measurement samples. You can choose to display graphs for current, voltage, and energy.
- In the **Power Log** window.

Power logs can be useful for finding peaks in the power consumption and by double-clicking on a value you can see the corresponding source code. The precision depends on the frequency of the samples, but there is a good chance that you find the source code sequence that caused the peak.

For more information, see the chapter *Power debugging*.

State logging Based on logged activity—state changes—for peripheral units and clocks, as well as for CPU modes generated by the debug probe or associated hardware. Choose to display the state logs:

- In the **Timeline** window, as a graph of the state changes.
- In the **State Log** window and in the **State Log Summary** window.

The information is useful for tracing the activity on the target system.

For more information, see the chapter *Power debugging*.

REQUIREMENTS FOR TIMELINE SUPPORT

Target system	Call Stack	Data logging		Interrupt logging	Power logging	State logging
C-SPY simulator	Yes	Yes	—	Yes	—	—

Table 7: Support for timeline information

Depending on the capabilities of the hardware, the debug probe, and the C-SPY driver you are using, trace-based timeline information is supported for:

Target system	Call Stack	Data logging	Interrupt logging	State logging	Power logging
C-SPY simulator	Yes	Yes	Yes		—
C-SPY FET Debugger driver	—	—	—	Yes	Yes

Table 8: Supported graphs in the Timeline window

For more information about requirements related to trace data, see *Requirements for using trace*, page 182.

Analyzing your application's timeline

These tasks are covered:

- Displaying a graph in the Timeline window
- Navigating in the graphs
- Analyzing performance using the graph data
- Getting started using data logging
- Getting started using data sampling

See also:

- *Debugging in the power domain*, page 248
- *Using the interrupt system*, page 271

DISPLAYING A GRAPH IN THE TIMELINE WINDOW

The **Timeline** window can display several graphs; follow this example procedure to display any of these graphs. For an overview of the graphs and what they display, see *Briefly about analyzing the timeline*, page 195.

- 1** Choose **Project>Options>FET Debugger>Setup** and select **Enable ULP/LPMx.5 debug**.
If you are using the C-SPY simulator, choose **Simulator>Simulated Frequency** to set up a frequency that matches the simulated hardware.
- 2** Choose **Timeline** from the C-SPY driver menu to open the **Timeline** window.
- 3** In the **Timeline** window, right-click in the window and choose **Select Graphs** from the context menu to select which graphs to be displayed.
- 4** In the **Timeline** window, right-click in the graph area and choose **Enable** from the context menu to enable a specific graph.
- 5** For the Data Log graph, you must set a Data Log breakpoint for each variable you want a graphical representation of in the **Timeline** window. See *Data Log breakpoints dialog box*, page 127.
- 6** Click **Go** on the toolbar to start executing your application. The graphs that you have enabled appear.

NAVIGATING IN THE GRAPHS

After you have performed the steps in *Displaying a graph in the Timeline window*, page 198, you can use any of these alternatives to navigate in the graph:

- Right-click and from the context menu choose **Zoom In** or **Zoom Out**.
Alternatively, use the + and – keys. The graph zooms in or out depending on which command you used.
- Right-click in the graph and from the context menu choose **Navigate** and the appropriate command to move backwards and forwards on the graph. Alternatively, use any of the shortcut keys: arrow keys, Home, End, and Ctrl+End.
- Double-click on a sample of interest to highlight the corresponding source code in the editor window and in the **Disassembly** window.
- Click on the graph and drag to select a time interval, which will correlate to the running application. The selection extends vertically over all graphs, but appears highlighted in a darker color for the selected graph. Press Enter or right-click and

from the context menu choose **Zoom>Zoom to Selection**. The selection zooms in. Use the navigation keys in combination with the Shift key to extend the selection.

ANALYZING PERFORMANCE USING THE GRAPH DATA

The **Timeline** window provides a set of tools for analyzing the graph data.

- 1 In the **Timeline** window, right-click and choose **Time Axis Unit** from the context menu. Select which unit to be used on the time axis; choose between **Seconds** and **Cycles**. If **Cycles** is not available, the graphs are based on different clock sources.
- 2 Execute your application to display a graph, following the steps described in *Displaying a graph in the Timeline window*, page 198.
- 3 Whenever execution stops, point at the graph with the mouse pointer to get detailed tooltip information for that location.

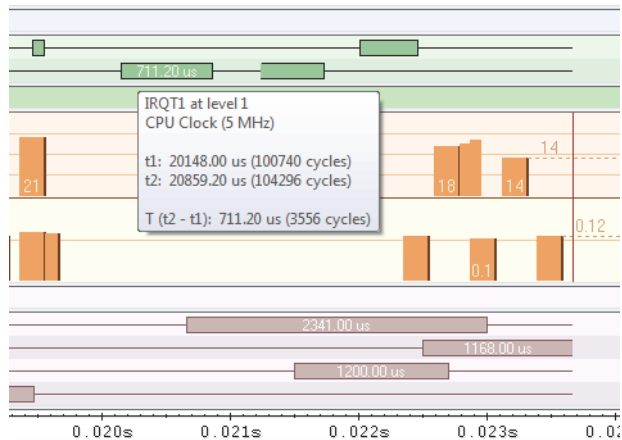

Note that if you have enabled several graphs, you can move the mouse pointer over the different graphs to get graph-specific information.

- 4 Click in the graph and drag to select a time interval. Point in the graph with the mouse pointer to get timing information for the selection.

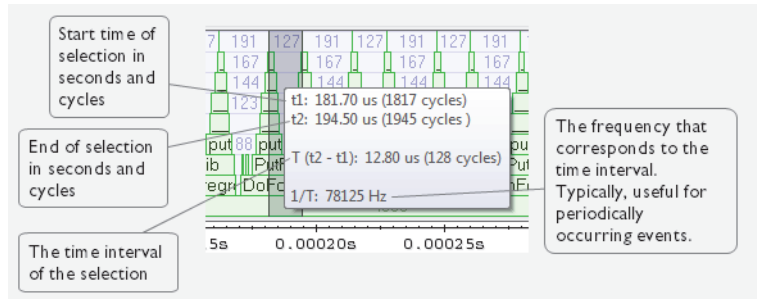

GETTING STARTED USING DATA LOGGING

- 1 To set a data log breakpoint, use one of these methods:
 - In the **Breakpoints** window, right-click and choose **New Breakpoint>Data Log** to open the breakpoints dialog box. Set a breakpoint on the memory location that you want to collect log information for. This can be specified either as a variable or as an address.
 - In the **Memory** window, select a memory area, right-click and choose **Set Data Log Breakpoint** from the context menu. A breakpoint is set on the start address of the selection.
 - In the editor window, select a variable, right-click and choose **Set Data Log Breakpoint** from the context menu. The breakpoint will be set on the part of the variable that the microcontroller can access using one instruction.

You can set up to four data log breakpoints. For more information, see *Data Log breakpoints*, page 109.
- 2 Choose **C-SPY driver>Data Log** to open the **Data Log** window. Optionally, you can also choose:
 - **C-SPY driver>Data Log Summary** to open the **Data Log Summary** window
 - **C-SPY driver>Timeline** to open the **Timeline** window to view the Data Log graph.
- 3 From the context menu, available in the **Data Log** window, choose **Enable** to enable the logging.
- 4 Start executing your application program to collect the log information.
- 5 To view the data log information, look in the **Data Log** window, the **Data Log Summary** window, or the Data Log graph in the **Timeline** window.
- 6 If you want to save the log or summary to a file, choose **Save to log file** from the context menu in the window in question.

- 7 To disable data logging, choose **Disable** from the context menu in each window where you have enabled it.

GETTING STARTED USING DATA SAMPLING

- 1 Choose *C-SPY driver*>**Data Sample Setup** to open the **Data Sample Setup** window.
- 2 In the **Data Sample Setup** window, perform these actions:
 - In the **Expression** column, type the name of the variable for which you want to sample data. The variable must be an integral type with a maximum size of 32 bits and you can specify up to four variables. Make sure that the checkbox is selected for the variable that you want to sample.
 - In the **Sampling interval** column, type the number of milliseconds to pass between the samples.
- 3 To view the result of data sampling, you must enable it in the window in question:
 - Choose *C-SPY driver*>**Data Sample** to open the **Data Sample** window. From the context menu, choose **Enable**.
 - Choose *C-SPY driver*>**Sampled Graphs** to open the **Sampled Graphs** window. From the context menu, choose **Enable**.
- 4 Start executing your application program. This starts the data sampling. When the execution stops, for example because a breakpoint is triggered, you can view the result either in the **Data Sample** window or as the Data Sample graph in the **Sampled Graphs** window
- 5 If you want to save the log or summary to a file, choose **Save to log file** from the context menu in the window in question.
- 6 To disable data sampling, choose **Disable** from the context menu in each window where you have enabled it.

Reference information on application timeline

Reference information about:

- *Data Log window*, page 202
- *Data Log Summary window*, page 205
- *Data Sample Setup window*, page 209
- *Data Sample window*, page 208
- *Sampled Graphs window*, page 211
- *Timeline window—Call Stack graph*, page 215

- *Timeline window—Data Log graph*, page 218
- *Viewing Range dialog box*, page 222

See also:

- *Timeline window—Interrupt Log graph*, page 287
- *Timeline window—Power graph*, page 257
- *Timeline window—State Log graph*, page 264

Data Log window

The **Data Log** window is available from the C-SPY driver menu.

Time	Program Counter	l1	Address	s2	Address
0.160us	---			W 0x0000	@ 0x2004
0.160us	0xFFE00049	-	@ 0x2000		
24.480us	0xFFE000B5			R 0x0000	@ 0x2006
24.720us	0xFFE000BF			W 0x0042	@ 0x2004
24.760us	0xFFE000C6			R 0x0042	@ 0x2006
24.960us	0xFFE000E4	W 0x00004444	@ 0x2000		
78.760us	0xFFE00104			R 0x0042	@ 0x2004+?
79.000us	---			W 0x0084	@ 0x2004
100.800us	0xFFE00104			R 0x0084	@ 0x2006
101.040us	0xFFE0010E			W 0x00C6	@ 0x2004
136.640us	Overflow				
136.880us	0xFFE0010E			-	@ 0x2004

White rows indicate read accesses

Grey rows indicate write accesses

Use this window to log accesses to up to four different memory locations or areas.

Note: There is a limit on the number of saved logs. When this limit is exceeded, the oldest entries in the buffer are erased.

See also *Getting started using data logging*, page 200.

Requirements

The C-SPY simulator.

Display area

Each row in the display area shows the time, the program counter, and, for every tracked data object, its value and address. All information is cleared on reset. The information is displayed in these columns:

Time

If the time is displayed in italics, the target system has not been able to collect a correct time, but instead had to approximate it.

This column is available when you have selected **Show time** from the context menu.

Cycles

The number of cycles from the start of the execution until the event.

If a cycle is displayed in italics, the target system has not been able to collect a correct time, but instead had to approximate it.

This column is available when you have selected **Show cycles** from the context menu.

Program Counter*

Displays one of these:

An address, which is the content of the PC, that is, the address of the instruction that performed the memory access.

---, the target system failed to provide the debugger with any information.

Overflow in red, the communication channel failed to transmit all data from the target system.

Value

Displays the access type and the value (using the access size) for the location or area you want to log accesses to. For example, if zero is read using a byte access it will be displayed as 0x00, and for a long access it will be displayed as 0x00000000.

To specify what data you want to log accesses to, use the **Data Log** breakpoint dialog box. See *Data Log breakpoints*, page 109.

Address

The actual memory address that is accessed. For example, if only a byte of a word is accessed, only the address of the byte is displayed. The address is calculated as base address + offset, where the base address is retrieved from the **Data Log** breakpoint dialog box and the offset is retrieved from the logs. If the log from the target system does not provide the debugger with an offset, the offset contains + ?.

* You can double-click a line in the display area. If the value of the PC for that line is available in the source code, the editor window displays the corresponding source code (this does not include library source code).

Context menu

This context menu is available:

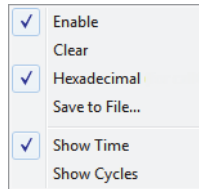

These commands are available:

Enable

Enables the logging system. The system will log information also when the window is closed.

Clear

Deletes the log information. Note that this will also happen when you reset the debugger.

Hexadecimal

Toggles between displaying the selected value in decimal or hexadecimal format. Note that this setting also affects the log window.

Save to File

Displays a standard file selection dialog box where you can select the destination file for the log information. The entries in the log file are separated by TAB and LF characters. An X in the **Approx** column indicates that the timestamp is an approximation.

Show Time

Displays the **Time** column.

If the **Time** column is displayed by default in the C-SPY driver you are using, this menu command is not available.

Show Cycles

Displays the **Cycles** column.

If the **Cycles** column is not supported in the C-SPY driver you are using, this menu command is not available.

Data Log Summary window

The **Data Log Summary** window is available from the C-SPY driver menu.

Data	Total Accesses	Read Accesses	Write Accesses	Unknown Accesses
tVar1	42	0	25	17
tVar2	66	17	49	0
tVar3	32	32	0	0

Approximative time count: 16
 Overflow count: 8
 Current time: 4301.52 us

This window displays a summary of data accesses to specific memory location or areas.

See also *Getting started using data logging*, page 200.

Requirements

The C-SPY simulator.

Display area

Each row in this area displays the type and the number of accesses to each memory location or area in these columns. Summary information is listed at the bottom of the display area.

Data

The name of the data object you have selected to log accesses to. To specify what data object you want to log accesses to, use the **Data Log** breakpoint dialog box. See *Data Log breakpoints*, page 109.

Total Accesses

The total number of accesses.

If the sum of read accesses and write accesses is less than the total accesses, the target system for some reason did not provide valid access type information for all accesses.

Read Accesses

The total number of read accesses.

Write Accesses

The total number of write accesses.

Unknown Accesses

The number of unknown accesses, in other words, accesses where the access type is not known.

Approximative time count

The information displayed depends on the C-SPY driver you are using.

For some C-SPY drivers, this information is not displayed or the value is always zero. In this case, all logs have an exact time stamp.

For other C-SPY drivers, a non-zero value is displayed. The value represents the amount of logs with an approximative time stamp. This might happen if the bandwidth in the communication channel is too low compared to the amount of data packets generated by the CPU or if the CPU generated packets with an approximative time stamp.

Overflow count

The information displayed depends on the C-SPY driver you are using.

For some C-SPY drivers, this information is not displayed or the value is always zero.

For other C-SPY drivers, the number represents the amount of overflows in the communication channel which can cause logs to be lost. If this happens, it indicates that logs might be incomplete. To solve this, make sure not to use all C-SPY log features simultaneously or check used bandwidth for the communication channel.

Current time

/Current cycles

The information displayed depends on the C-SPY driver you are using.

For some C-SPY drivers, the value is always zero or not visible at all.

For other C-SPY drivers, the number represents the current time or cycles—the number of cycles or the execution time since the start of execution.

Context menu

This context menu is available:

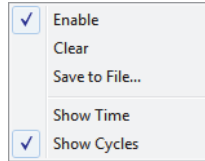

These commands are available:

Enable

Enables the logging system. The system will log information also when the window is closed.

Clear

Deletes the log information. Note that this will also happen when you reset the debugger.

Save to File

Displays a standard file selection dialog box where you can select the destination file for the log information. The entries in the log file are separated by `TAB` and `LF` characters. An **X** in the **Approx** column indicates that the timestamp is an approximation.

Show Time

Displays the **Time** column.

If the **Time** column is displayed by default in the C-SPY driver you are using, this menu command is not available.

Show Cycles

Displays the **Cycles** column.

If the **Cycles** column is not supported in the C-SPY driver you are using, this menu command is not available.

Data Sample window

The **Data Sample** window is available from the C-SPY driver menu.

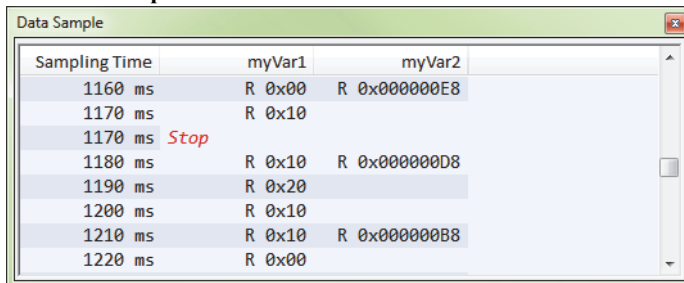

Sampling Time	myVar1	myVar2
1160 ms	R 0x00	R 0x000000E8
1170 ms	R 0x10	
1170 ms <i>Stop</i>		
1180 ms	R 0x10	R 0x000000D8
1190 ms	R 0x20	
1200 ms	R 0x10	
1210 ms	R 0x10	R 0x000000B8
1220 ms	R 0x00	

Use this window to view the result of the data sampling for the variables you have selected in the **Data Sample Setup** window.

Choose **Enable** from the context menu to enable data sampling.

See also *Getting started using data sampling*, page 201.

Requirements

A device that supports the trace buffer.

Display area

This area contains these columns:

Sampling Time

The time when the data sample was collected. Time starts at zero after a reset. Every time the execution stops, a red `STOP` indicates when the stop occurred.

The selected expression

The column headers display the names of the variables that you selected in the **Data Sample Setup** window. The column cells display the sampling values for the variable.

* You can double-click a row in the display area. If you have enabled the data sample graph in the **Sampled Graphs** window, the selection line will be moved to reflect the time of the row you double-clicked.

Context menu

This context menu is available:

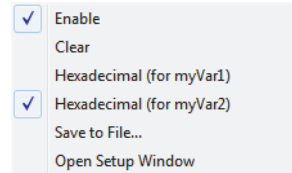

These commands are available:

Enable

Enables data sampling.

Clear

Clears the sampled data.

Hexadecimal

Toggles between displaying the selected value in decimal or hexadecimal format. Note that this setting also affects the log window.

Save to File

Displays a standard file selection dialog box where you can select the destination file for the log information. The entries in the log file are separated by TAB and LF characters. An **X** in the **Approx** column indicates that the timestamp is an approximation.

Open setup window

Opens the **Data Sample Setup** window.

Data Sample Setup window

The **Data Sample Setup** window is available from the C-SPY driver menu.

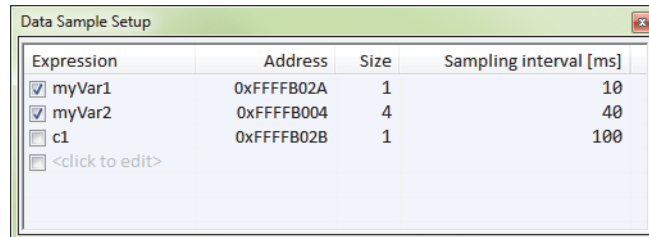

Use this window to specify up to four variables to sample data for. You can view the sampled data for the variables either in the **Data Sample** window or as graphs in the **Sampled Graphs** window.

See also *Getting started using data sampling*, page 201.

Requirements

A device that supports the trace buffer.

Display area

This area contains these columns:

Expression

Type the name of the variable which must be an integral type with a maximum size of 32 bits. Click the check box to enable or disable data sampling for the variable.

Alternatively, drag an expression from the editor window and drop it in the display area.

Variables in the expressions must be statically located, for example global variables.

Address

The actual memory address that is accessed. The column cells cannot be edited.

Size

The size of the variable, either 1, 2, or 4 bytes. The column cells cannot be edited.

Sampling interval [ms]

Type the number of milliseconds to pass between the samples. The shortest allowed interval is 10 ms and the interval you specify must be a multiple of that.

Note that the sampling time you specify is just the interval (according to the Microsoft Windows calculations) for how often C-SPY checks with the C-SPY driver (which in turn must check with the MCU for a value). If this takes longer than the sampling interval you have specified, the next sampling will be omitted. If this occurs, you might want to consider increasing the sampling time.

Context menu

This context menu is available:

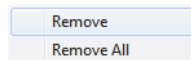

These commands are available:

Remove

Removes the selected variable.

Remove All

Removes all variables.

Sampled Graphs window

The **Sampled Graphs** window is available from the C-SPY driver menu.

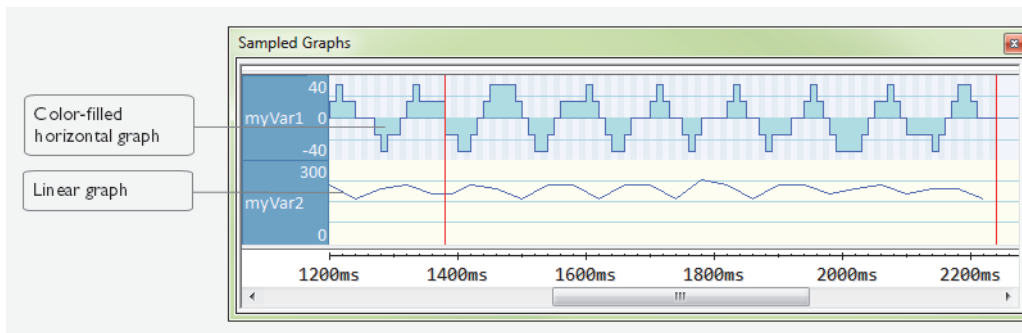

Use this window to display graphs for up to four different variables, and where:

- The graph displays how the value of the variable changes over time. The area on the left displays the limits, or range, of the Y-axis for the variable. You can use the context menu to change these limits. The graph is a graphical representation of the information in the **Data Sample** window, see *Data Sample window*, page 208.
- The graph can be displayed as levels, where a horizontal line—optionally color-filled—shows the value until the next sample. Alternatively, the graph can be linear, where a line connects consecutive samples.
- A red vertical line indicates the time of application execution stops.

At the bottom of the window, there is a shared time axis that uses seconds as the time unit.

To navigate in the graph, use any of these alternatives:

- Right-click and choose **Zoom In** or **Zoom Out** from the context menu. Alternatively, use the + and – keys to zoom.
- Right-click in the graph and choose **Navigate** and the appropriate command to move backward and forward on the graph. Alternatively, use any of the shortcut keys: arrow keys, Home, End, and Ctrl+End.
- Double-click on a sample to highlight the corresponding source code in the editor window and in the **Disassembly** window.

- Click on the graph and drag to select a time interval. Press Enter or right-click and choose **Zoom>Zoom to Selection** from the context menu. The selection zooms in.



Hover with the mouse pointer in the graph to get detailed tooltip information for that location.

See also *Getting started using data sampling*, page 201.



The graphs require hardware breakpoints. To preserve the required hardware breakpoints, use the option **Use only emulated breakpoints**, see *Breakpoints*, page 410.

Requirements

A device that supports the trace buffer.

Context menu

This context menu is available:

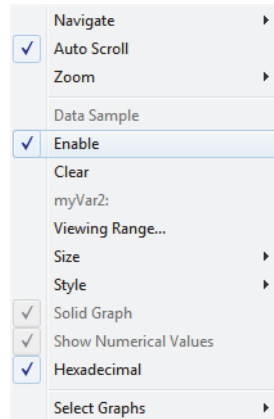

These commands are available:

Navigate

Commands for navigating in the graphs. Choose between:

Next moves the selection to the next relevant point in the graph. Shortcut key: right arrow.

Previous moves the selection to the previous relevant point in the graph. Shortcut key: left arrow.

First moves the selection to the first data entry in the graph. Shortcut key: Home.

Last moves the selection to the last data entry in the graph. Shortcut key: End.

End moves the selection to the last data in any displayed graph, in other words the end of the time axis. Shortcut key: Ctrl+End.

Auto Scroll

Toggles automatic scrolling on or off. When on, the most recently collected data is automatically displayed when you choose **Navigate>End**.

Zoom

Commands for zooming the window, in other words, changing the time scale. Choose between:

Zoom to Selection makes the current selection fit the window. Shortcut key: Return.

Zoom In zooms in on the time scale. Shortcut key: +

Zoom Out zooms out on the time scale. Shortcut key: -

1us, 10us, 100us makes an interval of 1 microsecond, 10 microseconds, or 100 microseconds, respectively, fit the window.

1ms, 10ms, 100ms makes an interval of 1 millisecond, 10 milliseconds, or 100 milliseconds, respectively, fit the window.

1s, 10s, 100s makes an interval of 1 second, 10 seconds, or 100 seconds, respectively, fit the window.

1k s, 10k s, 100k s makes an interval of 1,000 seconds, 10,000 seconds, or 100,000 seconds, respectively, fit the window.

1M s, 10M s, makes an interval of 1,000,000 seconds or 10,000,000 seconds, respectively, fit the window.

Data Sample

A menu item that shows that the Data Sample-specific commands below are available.

Open Setup window (Data Sample Graph)

Opens the **Data Sample Setup** window.

Enable

Toggles the display of the graph on or off. If you disable a graph, that graph will be indicated as **OFF** in the window. If no data has been collected for a graph, **no data** will appear instead of the graph.

Clear

Clears the sampled data.

Variable

The name of the variable for which the Data Sample-specific commands below apply. This menu item is context-sensitive, which means it reflects the Data Sample graph you selected in the **Sampled Graphs** window (one of up to four).

Viewing Range

Displays a dialog box, see *Viewing Range dialog box*, page 222.

Size

Controls the vertical size of the graph; choose between **Small**, **Medium**, and **Large**.

Style

Choose how to display the graph. Choose between:

Levels, where a horizontal line—optionally color-filled—shows the value until the next sample.

Linear, where a line connects consecutive samples.

Solid Graph

Displays the graph as a color-filled solid graph instead of as a thin line. This is only possible if the graph is displayed as Levels.

Hexadecimal

Toggles between displaying the selected value in decimal or hexadecimal format. Note that this setting also affects the log window.

Show Numerical Value

Shows the numerical value of the variable, in addition to the graph.

Select Graphs

Selects which graphs to display in the **Sampled Graphs** window.

Timeline window—Call Stack graph

The **Timeline** window is available from the *C-SPY driver* menu during a debug session.

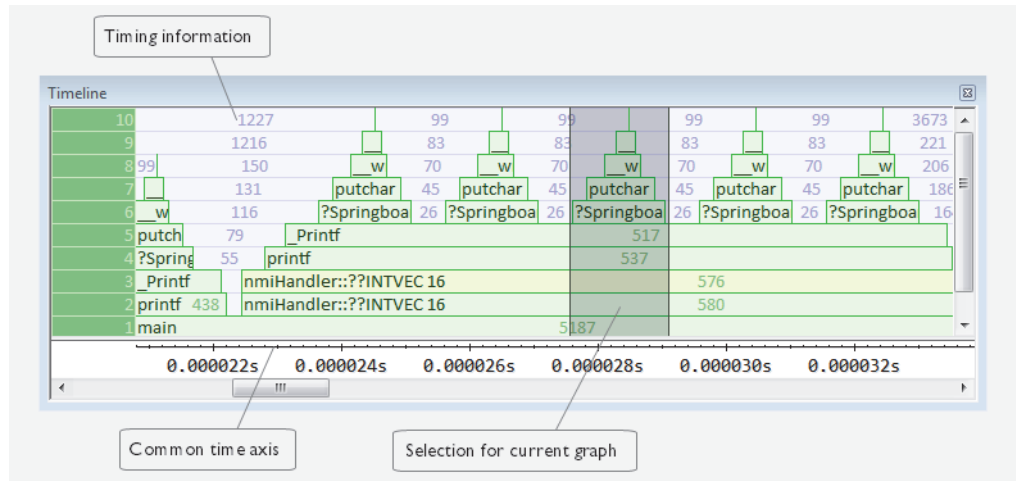

This window displays trace data represented as different graphs, in relation to a shared time axis.

The Call Stack graph displays the sequence of function calls and returns collected by the trace system.

Note: There is a limit on the number of saved logs. When this limit is exceeded, the oldest entries in the buffer are erased.

Requirements

The C-SPY simulator.

Display area for the Call Stack graph

Each function invocation is displayed as a horizontal bar which extends from the time of entry until the return. Called functions are displayed above its caller. The horizontal bars use four different colors:

- *Medium green* for normal C functions with debug information
- *Light green* for functions known to the debugger only through an assembler label
- *Medium yellow* for normal interrupt handlers, with debug information
- *Light yellow* for interrupt handlers known to the debugger only through an assembler label.

The timing information represents the number of cycles spent in, or between, the function invocations.

At the bottom of the window, there is a shared time axis that uses seconds or cycles as the time unit.

Click in the graph to display the corresponding source code.

Context menu

This context menu is available:

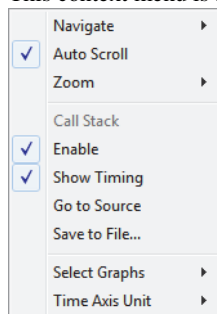

Note: The contents of this menu are dynamic and depend on which features that your combination of software and hardware supports. However, the list of menu commands below is complete and covers all possible commands.

These commands are available:

Navigate

Commands for navigating the graph(s). Choose between:

Next moves the selection to the next relevant point in the graph. Shortcut key: right arrow.

Previous moves the selection backward to the previous relevant point in the graph. Shortcut key: left arrow.

First moves the selection to the first data entry in the graph. Shortcut key: Home.

Last moves the selection to the last data entry in the graph. Shortcut key: End.

End moves the selection to the last data in any displayed graph, in other words the end of the time axis. Shortcut key: Ctrl+End.

Auto Scroll

Toggles automatic scrolling on or off. When on, the most recently collected data is automatically displayed when you choose **Navigate>End**.

Zoom

Commands for zooming the window, in other words, changing the time scale. Choose between:

Zoom to Selection makes the current selection fit the window. Shortcut key: Return.

Zoom In zooms in on the time scale. Shortcut key: +

Zoom Out zooms out on the time scale. Shortcut key: –

10ns, 100ns, 1us, etc makes an interval of 10 nanoseconds, 100 nanoseconds, 1 microsecond, respectively, fit the window.

1ms, 10ms, etc makes an interval of 1 millisecond or 10 milliseconds, respectively, fit the window.

10m, 1h, etc makes an interval of 10 minutes or 1 hour, respectively, fit the window.

Call Stack

A heading that shows that the Call stack-specific commands below are available.

Enable

Toggles the display of the graph on or off. If you disable a graph, that graph will be indicated as **OFF** in the window. If no data has been collected for a graph, **no data** will appear instead of the graph.

Show Timing

Toggles the display of the timing information on or off.

Go To Source

Displays the corresponding source code in an editor window, if applicable.

Save to File

Saves all contents (or the selected contents) of the Call Stack graph to a file. The menu command is only available when C-SPY is not running.

Select Graphs

Selects which graphs to be displayed in the **Timeline** window.

Time Axis Unit

Selects the unit used in the time axis; choose between **Seconds** and **Cycles**.

If **Cycles** is not available, the graphs are based on different clock sources. In that case you can view cycle values as tooltip information by pointing at the graph with your mouse pointer.

Profile Selection

Enables profiling time intervals in the **Function Profiler** window. Note that this command is only available if the C-SPY driver supports PC Sampling.

Timeline window—Data Log graph

The **Timeline** window is available from the C-SPY driver menu during a debug session.

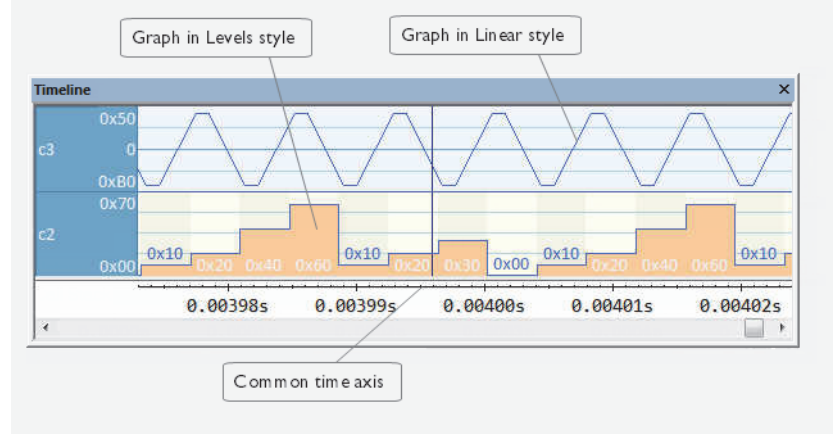

This window displays trace data represented as different graphs, in relation to a shared time axis.

The Data Log graph displays the data logs collected by the trace system, for up to four different variables or address ranges specified as Data Log breakpoints.

Note: There is a limit on the number of saved logs. When this limit is exceeded, the oldest entries in the buffer are erased.

Requirements

The C-SPY simulator.

Display area for the Data Log graph

Where:

- The label area at the left end of the graph displays the variable name or the address for which you have specified the Data Log breakpoint.
- The graph itself displays how the value of the variable changes over time. The label area also displays the limits, or range, of the Y-axis for a variable. You can use the

context menu to change these limits. The graph is a graphical representation of the information in the **Data Log** window, see *Data Log window*, page 202.

- The graph can be displayed either as a thin line between consecutive logs or as a rectangle for every log (optionally color-filled).
- A red vertical line indicates overflow, which means that the communication channel failed to transmit all data logs from the target system. A red question mark indicates a log without a value.

At the bottom of the window, there is a shared time axis that uses seconds or cycles as the time unit.

Context menu

This context menu is available:

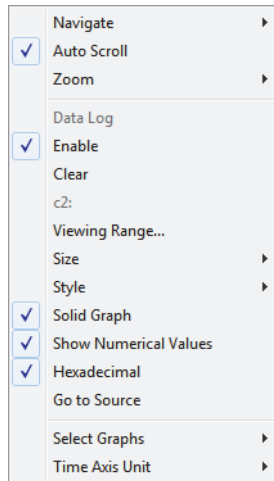

Note: The contents of this menu are dynamic and depend on which features that your combination of software and hardware supports. However, the list of menu commands below is complete and covers all possible commands.

These commands are available:

Navigate

Commands for navigating the graph(s). Choose between:

Next moves the selection to the next relevant point in the graph. Shortcut key: right arrow.

Previous moves the selection backward to the previous relevant point in the graph. Shortcut key: left arrow.

First moves the selection to the first data entry in the graph. Shortcut key: Home.

Last moves the selection to the last data entry in the graph. Shortcut key: End.

End moves the selection to the last data in any displayed graph, in other words the end of the time axis. Shortcut key: Ctrl+End.

Auto Scroll

Toggles automatic scrolling on or off. When on, the most recently collected data is automatically displayed when you choose **Navigate>End**.

Zoom

Commands for zooming the window, in other words, changing the time scale. Choose between:

Zoom to Selection makes the current selection fit the window. Shortcut key: Return.

Zoom In zooms in on the time scale. Shortcut key: +

Zoom Out zooms out on the time scale. Shortcut key: –

10ns, 100ns, 1us, etc makes an interval of 10 nanoseconds, 100 nanoseconds, 1 microsecond, respectively, fit the window.

1ms, 10ms, etc makes an interval of 1 millisecond or 10 milliseconds, respectively, fit the window.

10m, 1h, etc makes an interval of 10 minutes or 1 hour, respectively, fit the window.

Data Log

A heading that shows that the Data Log-specific commands below are available.

Enable

Toggles the display of the graph on or off. If you disable a graph, that graph will be indicated as **OFF** in the window. If no data has been collected for a graph, **no data** will appear instead of the graph.

Clear

Deletes the log information. Note that this will also happen when you reset the debugger.

Variable

The name of the variable for which the Data Log-specific commands below apply. This menu command is context-sensitive, which means it reflects the Data Log graph you selected in the **Timeline** window (one of up to four).

Viewing Range

Displays a dialog box, see *Viewing Range dialog box*, page 222.

Size

Determines the vertical size of the graph; choose between **Small**, **Medium**, and **Large**.

Solid Graph

Displays the graph as a color-filled solid graph instead of as a thin line.

Show Numerical Value

Shows the numerical value of the variable, in addition to the graph.

Hexadecimal

Toggles between displaying the selected value in decimal or hexadecimal format. Note that this setting also affects the log window.

Go To Source

Displays the corresponding source code in an editor window, if applicable.

Select Graphs

Selects which graphs to be displayed in the **Timeline** window.

Time Axis Unit

Selects the unit used in the time axis; choose between **Seconds** and **Cycles**.

If **Cycles** is not available, the graphs are based on different clock sources. In that case you can view cycle values as tooltip information by pointing at the graph with your mouse pointer.

Viewing Range dialog box

The **Viewing Range** dialog box is available from the context menu that appears when you right-click in any graph in the **Timeline** window that uses the linear, levels or columns style.

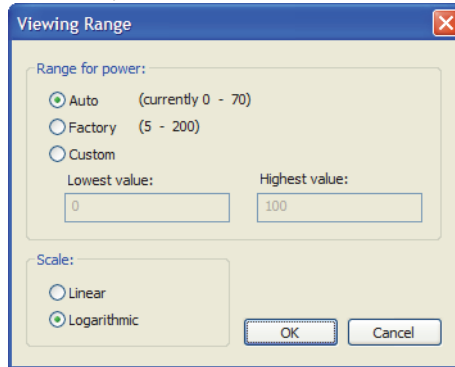

Use this dialog box to specify the value range, that is, the range for the Y-axis for the graph.

Requirements

The C-SPY FET Debugger driver.

Range for ...

Selects the viewing range for the displayed values:

Auto

Uses the range according to the range of the values that are actually collected, continuously keeping track of minimum or maximum values. The currently computed range, if any, is displayed in parentheses. The range is rounded to reasonably *even* limits.

Factory

For the Power Log graph: Uses the range according to the properties of the measuring hardware (only if supported by the product edition you are using).

For the other graphs: Uses the range according to the value range of the variable, for example 0–65535 for an unsigned 16-bit integer.

Custom

Use the text boxes to specify an explicit range.

Scale

Selects the scale type of the Y-axis:

- **Linear**
- **Logarithmic**

Profiling

- Introduction to the profiler
- Using the profiler
- Reference information on the profiler

Introduction to the profiler

These topics are covered:

- Reasons for using the profiler
- Briefly about the profiler
- Requirements for using the profiler

REASONS FOR USING THE PROFILER

Function profiling can help you find the functions in your source code where the most time is spent during execution. You should focus on those functions when optimizing your code. A simple method of optimizing a function is to compile it using speed optimization. Alternatively, you can move the data used by the function into more efficient memory. For detailed information about efficient memory usage, see the *IAR C/C++ Compiler User Guide for MSP430*.

Alternatively, you can use *filtered profiling*, which means that you can exclude, for example, individual functions from being profiled. To profile only a specific part of your code, you can select a *time interval*—using the **Timeline** window—for which C-SPY produces profiling information.

Instruction profiling can help you fine-tune your code on a very detailed level, especially for assembler source code. Instruction profiling can also help you to understand where your compiled C/C++ source code spends most of its time, and perhaps give insight into how to rewrite it for better performance.

BRIEFLY ABOUT THE PROFILER

Function profiling information is displayed in the **Function Profiler** window, that is, timing information for the functions in an application. Profiling must be turned on explicitly using a button on the window's toolbar, and will stay enabled until it is turned off.

Instruction profiling information is displayed in the **Disassembly** window, that is, the number of times each instruction has been executed.

Profiling sources

The profiler can use different mechanisms, or *sources*, to collect profiling information. Depending on the available trace source features, one or more of the sources can be used for profiling:

- *Trace (calls)*

The full instruction trace is analyzed to determine all function calls and returns. When the collected instruction sequence is incomplete or discontinuous, the profiling information is less accurate.

- *Trace (flat)*

Each instruction in the full instruction trace or each PC Sample is assigned to a corresponding function or code fragment, without regard to function calls or returns. This is most useful when the application does not exhibit normal call/return sequences, such as when you are using an RTOS, or when you are profiling code which does not have full debug information.

Power sampling

Some debug probes support sampling of the power consumption of the development board. Each sample is associated with a PC sample and represents the power consumption (actually, the electrical current) for a small time interval preceding the time of the sample. When the profiler is set to use *Power Sampling*, additional columns are displayed in the **Profiler** window. Each power sample is associated with a function or code fragment, just as with regular PC Sampling.

Note that this does not imply that all the energy corresponding to a sample can be attributed to that function or code fragment. The time scales of power samples and instruction execution are vastly different; during one power measurement, the CPU has typically executed many thousands of instructions. Power Sampling is a statistics tool.

REQUIREMENTS FOR USING THE PROFILER

The C-SPY simulator supports the profiler; there are no specific requirements.

The function profiler is available in the hardware debugger system if your device and debug probe support it. The instruction profiler is not available in the hardware debugger system.

This table lists the C-SPY driver profiling support:

C-SPY driver	Trace (calls)	Trace (flat)	Power
C-SPY simulator	Yes	Yes	—
C-SPY FET Debugger driver	—	—	Yes

Table 9: C-SPY driver profiling support

Using the profiler

These tasks are covered:

- Getting started using the profiler on function level
- Analyzing the profiling data
- Getting started using the profiler on instruction level



GETTING STARTED USING THE PROFILER ON FUNCTION LEVEL

To display function profiling information in the Function Profiler window:

- 1 Build your application using these options:

Category	Setting
C/C++ Compiler	Output>Generate debug information
Linker	Output>Format>Debug information for C-SPY

Table 10: Project options for enabling the profiler

- 2 To set up the profiler for function profiling, choose **Project>Options>Debugger>FET Debugger>Setup** and select **Enable ULP/LPMx.5 debug**.
- 3  When you have built your application and started C-SPY, choose **C-SPY driver>Function Profiler** to open the **Function Profiler** window, and click the **Enable** button to turn on the profiler. Alternatively, choose **Enable** from the context menu that is available when you right-click in the **Function Profiler** window.
- 4 Start executing your application to collect the profiling information.
- 5 Profiling information is displayed in the **Function Profiler** window. To sort, click on the relevant column header.
- 6  When you start a new sampling, you can click the **Clear** button—alternatively, use the context menu—to clear the data.

ANALYZING THE PROFILING DATA

Here follow some examples of how to analyze the data.

The first figure shows the result of profiling using **Source: Trace (calls)**. The profiler follows the program flow and detects function entries and exits.

- For the **InitFib** function, **Flat Time** 231 is the time spent inside the function itself.
- For the **InitFib** function, **Acc Time** 487 is the time spent inside the function itself, including all functions **InitFib** calls.
- For the **InitFib/GetFib** function, **Acc Time** 256 is the time spent inside **GetFib** (but only when called from **InitFib**), including any functions **GetFib** calls.
- Further down in the data, you can find the **GetFib** function separately and see all of its subfunctions (in this case none).

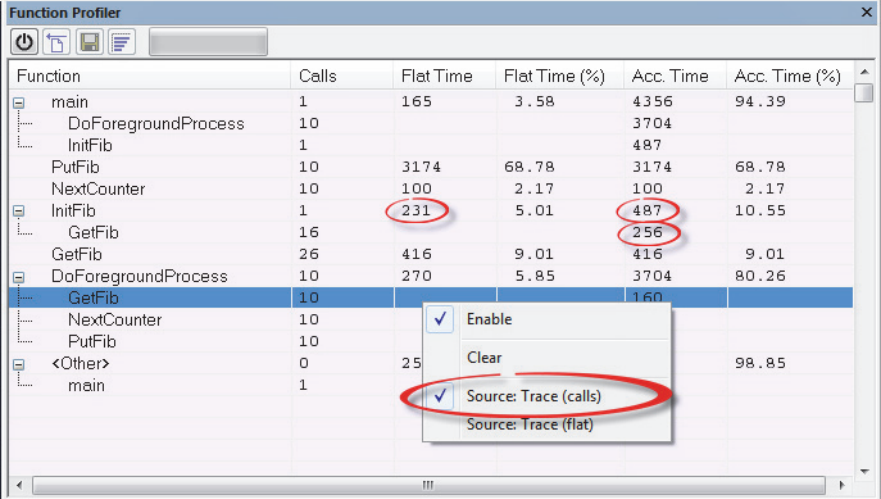

Function	Calls	Flat Time	Flat Time (%)	Acc. Time	Acc. Time (%)
main	1	165	3.58	4356	94.39
DoForegroundProcess	10			3704	
InitFib	1			487	
PutFib	10	3174	68.78	3174	68.78
NextCounter	10	100	2.17	100	2.17
InitFib	1	231	5.01	487	10.55
GetFib	16			256	
GetFib	26	416	9.01	416	9.01
DoForegroundProcess	10	270	5.85	3704	80.26
GetFib	10			160	
NextCounter	10				
PutFib	10				
<Other>	0	25			98.85
main	1				

The second figure shows the result of profiling using **Source: Trace (flat)**. In this case, the profiler does not follow the program flow, instead the profiler only detects whether the PC address is within the function scope. For incomplete trace data, the data might contain minor errors.

For the **InitFib** function, **Flat Time** 231 is the time (number of hits) spent inside the function itself.

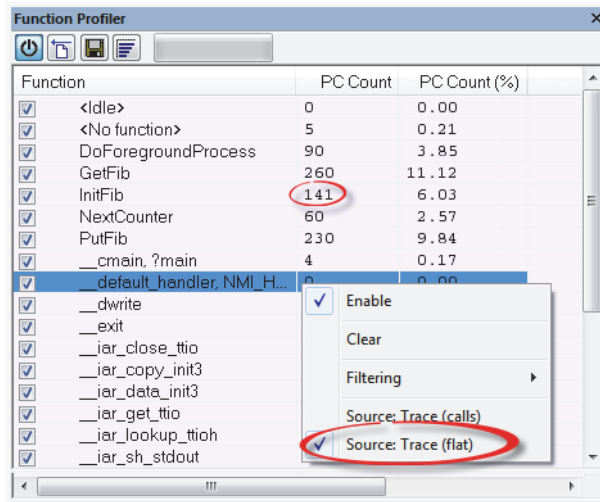

To secure valid data when using a debug probe, make sure to use the maximum trace buffer size and set a breakpoint in your code to stop the execution before the buffer is full.

Note: The <No function> entry represents PC values that are not within the known C-SPY ranges for the application.

GETTING STARTED USING THE PROFILER ON INSTRUCTION LEVEL

To display instruction profiling information in the Disassembly window:

- 1 To set up the profiler for function profiling, choose **Project>Options>Debugger>FET Debugger>Setup** and select **Enable ULP/LPMx.5 debug**.
- 2 When you have built your application and started C-SPY, choose **View>Disassembly** to open the **Disassembly** window, and choose **Instruction Profiling>Enable** from the context menu that is available when you right-click in the left-hand margin of the **Disassembly** window.
- 3 Make sure that the **Show** command on the context menu is selected, to display the profiling information.
- 4 Start executing your application to collect the profiling information.

- 5 When the execution stops, for instance because the program exit is reached or a breakpoint is triggered, you can view instruction level profiling information in the left-hand margin of the window.

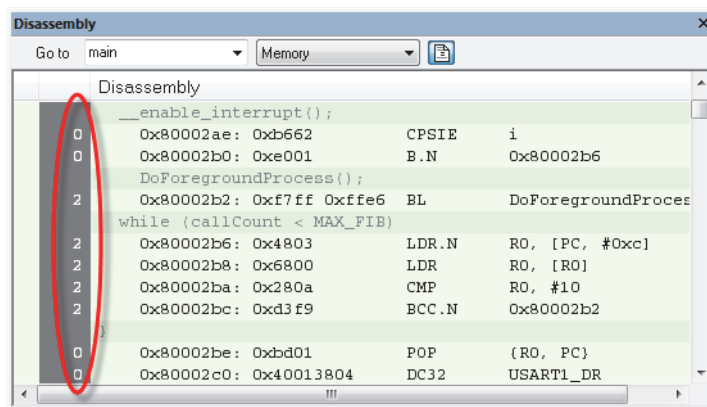

For each instruction, the number of times it has been executed is displayed.

Reference information on the profiler

Reference information about:

- *Function Profiler window*, page 230

See also:

- *Disassembly window*, page 65

Function Profiler window

The **Function Profiler** window is available from the C-SPY driver menu.

Function	Calls	Flat Time	Flat Time (%)	Acc. Time	Acc. Time (%)
DoForegroundProcess	49	5770	31.14	7198	38.84
GetFib	0	0	0.00	0	0.00
InitFib	0	0	0.00	0	0.00
InitUart	0	0	0.00	0	0.00
PutFib	4	1332	7.19	1332	7.19
UartReceiveHandler	4	96	0.52	1428	7.71
main	0	0	0.00	0	0.00

This figure reflects the C-SPY simulator driver.

This window displays function profiling information.

When Trace (flat) is selected, a checkbox appears on each line in the left-side margin of the window. Use these checkboxes to include or exclude lines from the profiling. Excluded lines are dimmed but not removed.

See also *Using the profiler*, page 227.

Requirements

One of these alternatives:

- The C-SPY simulator.
- The C-SPY FET Debugger driver and an MSP430 device with JSTATE register and an eZFET or MSP-FET debug probe.

Note that if you are using the C-SPY FET Debugger driver, the profiling sources Trace (flat) and Trace (calls) are not available.

Toolbar

The toolbar contains:



Enable/Disable

Enables or disables the profiler.



Clear

Clears all profiling data.



Save

Opens a standard **Save As** dialog box where you can save the contents of the window to a file, with tab-separated columns. Only non-expanded rows are included in the list file.



Graphical view

Overlays the values in the percentage columns with a graphical bar.

Progress bar

Displays a backlog of profiling data that is still being processed. If the rate of incoming data is higher than the rate of the profiler processing the data, a backlog is accumulated. The progress bar indicates that the profiler is still processing data, but also approximately how far the profiler has come in the process.

Note that because the profiler consumes data at a certain rate and the target system supplies data at another rate, the amount of data remaining to be processed can both increase and decrease. The progress bar can grow and shrink accordingly.

Display area

The content in the display area depends on which source that is used for the profiling information:

- *For the Trace (calls) source*, the display area contains one line for each function compiled with debug information enabled. When some profiling information has been collected, it is possible to expand rows of functions that have called other functions. The child items for a given function list all the functions that have been called by the parent function and the corresponding statistics.
- *For the Trace (flat) source*, the display area contains one line for each C function of your application, but also lines for sections of code from the runtime library or from other code without debug information, denoted only by the corresponding assembler labels. Each executed PC address from trace data is treated as a separate sample and is associated with the corresponding line in the **Profiling** window. Each line contains a count of those samples.

For information about which views that are supported in the C-SPY driver you are using, see *Requirements for using the profiler*, page 226.

More specifically, the display area provides information in these columns:

Function (All sources)

The name of the profiled C function.

Calls (Trace (calls))

The number of times the function has been called.

Flat time (Trace (calls))

The time expressed in cycles spent inside the function.

Flat time (%) (Trace (calls))

Flat time expressed as a percentage of the total time.

Acc. time (Trace (calls))

The time expressed in cycles spent inside the function and everything called by the function.

Acc. time (%) (Trace (calls))

Accumulated time expressed as a percentage of the total time.

PC Count (Trace (flat))

The number of executed instructions associated with the function.

PC Count (%) (Trace (flat))

The number of executed instructions associated with the function as a percentage of the total number of executed instructions.

Power Samples (Power Sampling)

The number of power samples associated with that function.

Energy (%) (Power Sampling)

The accumulated value of all measurements associated with that function, expressed as a percentage of all measurements.

Avg Current [mA] (Power Sampling)

The average measured value for all samples associated with that function.

Min Current [mA] (Power Sampling)

The minimum measured value for all samples associated with that function.

Max Current [mA] (Power Sampling)

The maximum measured value for all samples associated with that function.

Context menu

This context menu is available:

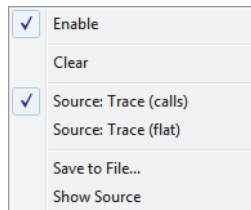

The contents of this menu depend on the C-SPY driver you are using.

These commands are available:

Enable

Enables the profiler. The system will also collect information when the window is closed.

Clear

Clears all profiling data.

Filtering

Selects which part of your code to profile. Choose between:

Check All—Excludes all lines from the profiling.

Uncheck All—Includes all lines in the profiling.

Load—Reads all excluded lines from a saved file.

Save—Saves all excluded lines to a file. Typically, this can be useful if you are a group of engineers and want to share sets of exclusions.

These commands are only available when using Trace (flat).

Source

Selects which source to be used for the profiling information. See also *Profiling sources*, page 226.

Note that the available sources depend on the C-SPY driver you are using.

Choose between:

Trace (calls)—the instruction count for instruction profiling is only as complete as the collected trace data.

Trace (flat)—the instruction count for instruction profiling is only as complete as the collected trace data.

Power Sampling

Toggles power sampling information on or off.

Save to File

Saves all profiling data to a file.

Show Source

Opens the editor window (if not already opened) and highlights the selected source line.

Code coverage

- Introduction to code coverage
- Using code coverage
- Reference information on code coverage

Introduction to code coverage

These topics are covered:

- Reasons for using code coverage
- Briefly about code coverage
- Requirements and restrictions for using code coverage

REASONS FOR USING CODE COVERAGE

The code coverage functionality is useful when you design your test procedure to verify whether all parts of the code have been executed. It also helps you identify parts of your code that are not reachable.

BRIEFLY ABOUT CODE COVERAGE

The **Code Coverage** window reports the status of the current code coverage analysis for C or C++ code. For every program, module, and function, the analysis shows the percentage of code that has been executed since code coverage was turned on up to the point where the application has stopped. In addition, all statements that have not been executed are listed. The analysis will continue until turned off.

Note: Assembler code is not covered in the **Code Coverage** window. To view code coverage for assembler code, use the **Disassembly** window.

REQUIREMENTS AND RESTRICTIONS FOR USING CODE COVERAGE

Code coverage is supported by the C-SPY simulator and there are no specific requirements or restrictions.

Using code coverage

These tasks are covered:

- Getting started using code coverage

GETTING STARTED USING CODE COVERAGE

To get started using code coverage:

- 1 Before you can use the code coverage functionality, you must build your application using these options:

Category	Setting
C/C++ Compiler	Output>Generate debug information
Linker	Format>Debug information for C-SPY

Table 11: Project options for enabling code coverage

- 2 After you have built your application and started C-SPY, choose **View>Code Coverage** to open the **Code Coverage** window.
- 3  Click the **Activate** button, alternatively choose **Activate** from the context menu, to switch on code coverage.
- 4 Start the execution. When the execution stops, for instance because the program exit is reached or a breakpoint is triggered, the code coverage information is updated automatically.

Reference information on code coverage

Reference information about:

- *Code Coverage window*, page 237

See also *Single stepping*, page 58.

Code Coverage window

The **Code Coverage** window is available from the **View** menu.

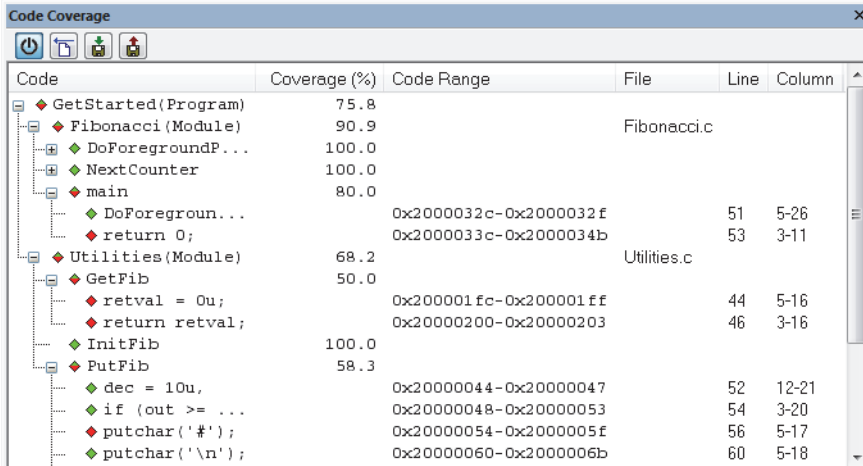

Code	Coverage (%)	Code Range	File	Line	Column
◆ GetStarted(Program)	75.8				
◆ Fibonacci (Module)	90.9		Fibonacci.c		
◆ DoForegroundP...	100.0				
◆ NextCounter	100.0				
◆ main	80.0				
◆ DoForegroun...		0x2000032c-0x2000032f		51	5-26
◆ return 0;		0x2000033c-0x2000034b		53	3-11
◆ Utilities (Module)	68.2		Utilities.c		
◆ GetFib	50.0				
◆ retval = 0u;		0x200001fc-0x200001ff		44	5-16
◆ return retval;		0x20000200-0x20000203		46	3-16
◆ InitFib	100.0				
◆ PutFib	58.3				
◆ dec = 10u,		0x20000044-0x20000047		52	12-21
◆ if (out >= ...		0x20000048-0x20000053		54	3-20
◆ putchar('#');		0x20000054-0x2000005f		56	5-17
◆ putchar('\n');		0x20000060-0x2000006b		60	5-18

This window reports the status of the current code coverage analysis. For every program, module, and function, the analysis shows the percentage of code that has been executed since code coverage was turned on to the point where the application has stopped. In addition, all statements that have not been executed are listed. The analysis will continue until turned off.

Only source code that was compiled with debug information is displayed. Therefore, startup code, exit code, and library code are not displayed in the window. Furthermore, coverage information for statements in inlined functions is not displayed. Only the statement containing the inlined function call is marked as executed.

A statement is considered to be executed when all its instructions have been executed. By default, when a statement has been executed, it is removed from the window and the percentage is increased correspondingly.

Requirements

The C-SPY simulator.

Toolbar

The toolbar contains buttons for switching code coverage on and off, clearing the code coverage information, and saving/restoring the code coverage session. See the description of the context menu for more detailed information.

The toolbar contains these buttons:



Activate

Switches code coverage on and off during execution.



Clear

Clears the code coverage information. All step points are marked as not executed.



Save session

Saves your code coverage session data to a *.dat file. This is useful if you for some reason must abort your debug session, but want to continue the session later on. This command might not be supported by the C-SPY driver you are using.



Restore session

Restores previously saved code coverage session data. This is useful if you for some reason must abort your debug session, but want to continue the session later on. This command might not be supported by the C-SPY driver you are using.

Display area

Double-clicking a statement or a function in the **Code Coverage** window displays that statement or function as the current position in the editor window, which becomes the active window.

These columns are available:

Code

The code coverage information as a tree structure, showing the program, module, function, and statement levels. The plus sign and minus sign icons allow you to expand and collapse the structure.

These icons give you an overview of the current status on all levels:

- Red diamond: 0% of the modules or functions has been executed.
- Green diamond: 100% of the modules or functions has been executed.
- Red and green diamond: Some of the modules or functions have been executed.

Red, green, and yellow colors can be used as highlight colors in the source editor window. In the editor window, the yellow color signifies partially executed.

Coverage (%)

The amount of statements that has been covered so far, that is, the number of executed statements divided with the total number of statements.

Code Range

The address range in code memory where the statement is located.

File

The source file where the step point is located.

Line

The source file line where the step point is located.

Column

The source file column where the step point is located.

Context menu

This context menu is available:

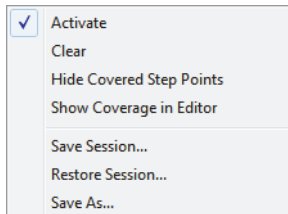

These commands are available:



Activate

Switches code coverage on and off during execution.



Clear

Clears the code coverage information. All step points are marked as not executed.

Hide Covered Step Points

Toggles the display of covered step points on and off. When this option is selected, executed statements are removed from the window.

Show Coverage in Editor

Toggles the red, green, and yellow highlight colors that indicate code coverage in the source editor window on and off.



Save session

Saves your code coverage session data to a * .dat file. This is useful if you for some reason must abort your debug session, but want to continue the session later on. This command is available on the toolbar. This command might not be supported by the C-SPY driver you are using.



Restore session

Restores previously saved code coverage session data. This is useful if you for some reason must abort your debug session, but want to continue the session later on. This command is available on the toolbar. This command might not be supported by the C-SPY driver you are using.

Save As

Saves the current code coverage result in a text file.

Power debugging

- Introduction to power debugging
- Optimizing your source code for power consumption
- Debugging in the power domain
- Reference information on power debugging

Introduction to power debugging

These topics are covered:

- Reasons for using power debugging
- Briefly about power debugging
- Requirements and restrictions for power debugging

REASONS FOR USING POWER DEBUGGING

Long battery lifetime is a very important factor for many embedded systems in almost any market segment: medical, consumer electronics, home automation, etc. The power consumption in these systems does not only depend on the hardware design, but also on how the hardware is used. The system software controls how it is used.

For examples of when power debugging can be useful, see *Optimizing your source code for power consumption*, page 243.

BRIEFLY ABOUT POWER DEBUGGING

Power debugging is based on the ability to sample the power consumption—more precisely, the power being consumed by the CPU and the peripheral units—and correlate each sample with the application's instruction sequence and hence with the source code and various events in the program execution.

Traditionally, the main software design goal has been to use as little memory as possible. However, by correlating your application's power consumption with its source code you can gain insight into how the software affects the power consumption, and thus how it can be minimized.

Power debugging in C-SPY supports the EnergyTrace™ Technology provided by Texas Instruments.

Measuring power consumption

Debug probes with EnergyTrace™ Technology support measure the power supplied to a target microcontroller. A software-controlled DC–DC converter generates the target power supply. The time density of the DC–DC converter charge pulses equals the power consumption of the target microcontroller. A built-in on-the-fly calibration circuit defines the energy equivalent of a single DC–DC charge pulse.

For more information about the debug probes, see the *MSP430 Hardware Tools User's Guide* on the Texas Instruments website.

Power debugging using C-SPY

C-SPY provides an interface for configuring your power debugging and a set of windows for viewing the power values:

- The **Power Log Setup** window is where you can specify a threshold and an action to be executed when the threshold is reached. This means that you can enable or disable the power measurement or you can stop the application's execution and determine the cause of unexpected power values.
- The **Power Log** window displays all logged power values. This window can be used for finding peaks in the power logging and because the values are correlated with the executed code, you can double-click on a value in the **Power Log** window to get the corresponding code. The precision depends on the frequency of the samples, but there is a good chance that you find the source code sequence that caused the peak.
- The Power graph in the **Timeline** window displays power values on a time scale. This provides a convenient way of viewing the power consumption in relation to the other information displayed in the window. The **Timeline** window is correlated to both the **Power Log** window, the source code window, and the **Disassembly** window, which means you are just a double-click away from the source code that corresponds to the values you see on the timeline.
- The **State Log** window logs activity—state changes—for peripheral units and clocks, as well as for CPU modes. The **State Log Summary** window displays a summary of the logged activity. The State Log graphs display a graphical view of the activity. The information is useful for tracing the activity on the target system.
- The **Function Profiler** window combines the function profiling with the power logging to display the power consumption per function—power profiling. You will get a list of values per function and also the average values together with max and min values. Thus, you will find the regions in the application that you should focus when optimizing for power consumption.

REQUIREMENTS AND RESTRICTIONS FOR POWER DEBUGGING

Power debugging in C-SPY support two capture modes, with different capabilities:

- EnergyTrace™, which can output timestamps, voltage, current, and energy information. This mode is available for all MSP430 devices with both MSP-FET (black box) and eZ-FET.
- EnergyTrace++™, which can output timestamps, state log information for peripheral units, clocks, and CPU modes (64-bit JSTATE register content), voltage, current, and energy information. This mode is available for all MSP430 devices with the JSTATE register, currently the MSP430FR59xx device family, together with both the MSP-FET (black box) and the eZ-FET debugger probe. The respective device-specific .menu file includes an `<energytrace>1</energytrace>` tag.

To use the features in C-SPY for power debugging, you also need:

- The C-SPY FET Debugger driver.

Note: The MSP-FET430UIF (gray box) and the eZ430 debug probes do not support power debugging.

Optimizing your source code for power consumption

This section gives some examples where power debugging can be useful and hopefully help you identify source code constructions that can be optimized for low power consumption.

These topics are covered:

- Waiting for device status
- Software delays
- DMA versus polled I/O
- Low-power mode diagnostics
- CPU frequency
- Detecting mistakenly unattended peripherals
- Peripheral units in an event-driven system
- Finding conflicting hardware setups
- Analog interference

WAITING FOR DEVICE STATUS

One common construction that could cause unnecessary power consumption is to use a poll loop for waiting for a status change of, for example a peripheral device. Constructions like this example execute without interruption until the status value changes into the expected state.

```
while (USBD_GetState() < USBD_STATE_CONFIGURED);
while ((BASE_PMC->PMC_SR & MC_MCKRDY) != PMC_MCKRDY);
```

To minimize power consumption, rewrite polling of a device status change to use interrupts if possible, or a timer interrupt so that the CPU can sleep between the polls.

SOFTWARE DELAYS

A software delay might be implemented as a `for` or `while` loop like for example:

```
i = 10000; /* A software delay */
do i--;
while (i != 0);
```

Such software delays will keep the CPU busy with executing instructions performing nothing except to make the time go by. Time delays are much better implemented using a hardware timer. The timer interrupt is set up and after that, the CPU goes down into a low power mode until it is awakened by the interrupt.

DMA VERSUS POLLED I/O

DMA has traditionally been used for increasing transfer speed. For MCUs there are plenty of DMA techniques to increase flexibility, speed, and to lower power consumption. Sometimes, CPUs can even be put into sleep mode during the DMA transfer. Power debugging lets you experiment and see directly in the debugger what effects these DMA techniques will have on power consumption compared to a traditional CPU-driven polled solution.

LOW-POWER MODE DIAGNOSTICS

Many embedded applications spend most of their time waiting for something to happen: receiving data on a serial port, watching an I/O pin change state, or waiting for a time delay to expire. If the processor is still running at full speed when it is idle, battery life is consumed while very little is being accomplished. So in many applications, the microcontroller is only active during a very small amount of the total time, and by placing it in a low-power mode during the idle time, the battery life can be extended considerably.

A good approach is to have a task-oriented design. In a task-oriented design, a task can be defined with the lowest priority, and it will only execute when there is no other task that needs to be executed. This idle task is the perfect place to implement power

management. In practice, every time the idle task is activated, it sets the microcontroller into a low-power mode. All MSP430 devices have a number of different low-power modes, in which different parts of the microcontroller can be turned off when they are not needed. The oscillator can for example either be turned off or switched to a lower frequency. In addition, individual peripheral units, timers, and the CPU can be stopped. The different low-power modes have different power consumption based on which peripherals are left turned on. A power debugging tool can be very useful when experimenting with different low-level modes.

You can use the Function profiler in C-SPY to compare power measurements for the task or function that sets the system in a low-power mode when different low-power modes are used. Both the mean value and the percentage of the total power consumption can be useful in the comparison.

CPU FREQUENCY

Power consumption in a CMOS MCU is theoretically given by the formula:

$$P = f * U^2 * k$$

where f is the clock frequency, U is the supply voltage, and k is a constant.

Power debugging lets you verify the power consumption as a factor of the clock frequency. A system that spends very little time in sleep mode at 10 MHz is expected to spend 50% of the time in sleep mode when running at 20 MHz. You can use the power data collected in C-SPY to verify the expected behavior, and if there is a non-linear dependency on the clock frequency, make sure to choose the operating frequency that gives the lowest power consumption.

DETECTING MISTAKENLY UNATTENDED PERIPHERALS

Peripheral units can consume much power even when they are not actively in use. If you are designing for low power, it is important that you disable the peripheral units and not just leave them unattended when they are not in use. But for different reasons, a peripheral unit can be left with its power supply on; it can be a careful and correct design decision, or it can be an inadequate design or just a mistake. If not the first case, then more power than expected will be consumed by your application. This will be easily revealed by the Power graph in the **Timeline** window. Double-clicking in the **Timeline** window where the power consumption is unexpectedly high will take you to the corresponding source code and disassembly code. In many cases, it is enough to disable the peripheral unit when it is inactive, for example by turning off its clock which in most cases will shut down its power consumption completely.

However, there are some cases where clock gating will not be enough. Analog peripherals like converters or comparators can consume a substantial amount of power

even when the clock is turned off. The **Timeline** window will reveal that turning off the clock was not enough and that you need to turn off the peripheral completely.

PERIPHERAL UNITS IN AN EVENT-DRIVEN SYSTEM

Consider a system where one task uses an analog comparator while executing, but the task is suspended by a higher-priority task. Ideally, the comparator should be turned off when the task is suspended and then turned on again once the task is resumed. This would minimize the power being consumed during the execution of the high-priority task.

This is a schematic diagram of the power consumption of an assumed event-driven system where the system at the point of time t_0 is in an inactive mode and the current is I_0 :



At t_1 , the system is activated whereby the current rises to I_1 which is the system's power consumption in active mode when at least one peripheral device turned on, causing the current to rise to I_1 . At t_2 , the execution becomes suspended by an interrupt which is handled with high priority. Peripheral devices that were already active are not turned off, although the task with higher priority is not using them. Instead, more peripheral devices are activated by the new task, resulting in an increased current I_2 between t_2 and t_3 where control is handed back to the task with lower priority.

The functionality of the system could be excellent and it can be optimized in terms of speed and code size. But in the power domain, more optimizations can be made. The shadowed area represents the energy that could have been saved if the peripheral devices that are not used between t_2 and t_3 had been turned off, or if the priorities of the two tasks had been changed.

If you use the **Timeline** window, you can make a closer examination and identify that unused peripheral devices were activated and consumed power for a longer period than necessary. Naturally, you must consider whether it is worth it to spend extra clock cycles to turn peripheral devices on and off in a situation like in the example.

FINDING CONFLICTING HARDWARE SETUPS

To avoid floating inputs, it is a common design practice to connect unused MCU I/O pins to ground. If your source code by mistake configures one of the grounded I/O pins as a logical 1 output, a high current might be drained on that pin. This high unexpected current is easily observed by reading the current value from the Power graph in the **Timeline** window. It is also possible to find the corresponding erratic initialization code by looking at the Power graph at application startup.

A similar situation arises if an I/O pin is designed to be an input and is driven by an external circuit, but your code incorrectly configures the input pin as output.

ANALOG INTERFERENCE

When mixing analog and digital circuits on the same board, the board layout and routing can affect the analog noise levels. To ensure accurate sampling of low-level analog signals, it is important to keep noise levels low. Obtaining a well-mixed signal design requires careful hardware considerations. Your software design can also affect the quality of the analog measurements.

Performing a lot of I/O activity at the same time as sampling analog signals causes many digital lines to toggle state at the same time, which might introduce extra noise into the AD converter.

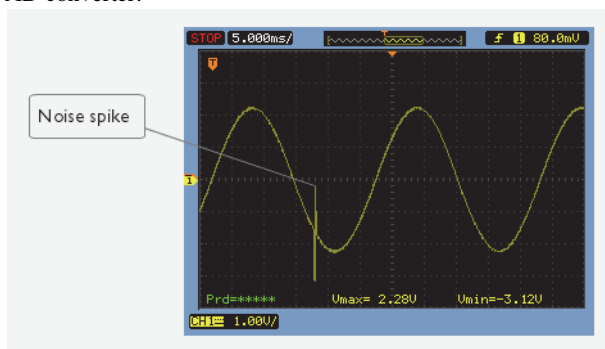

Power debugging will help you investigate interference from digital and power supply lines into the analog parts. Power spikes in the vicinity of AD conversions could be the source of noise and should be investigated. All data presented in the **Timeline** window

is correlated to the executed code. Simply double-clicking on a suspicious power value will bring up the corresponding C source code.

Debugging in the power domain

These tasks are covered:

- Displaying a power profile and analyzing the result
- Displaying the power profile on a device without EnergyTrace++
- Detecting unexpected power usage during application execution
- Measuring low power currents
- Changing the graph resolution

See also:

- *Timeline window—Power graph*, page 257

DISPLAYING A POWER PROFILE AND ANALYZING THE RESULT

To view the power profile on a device with EnergyTrace++:

- 1** Before you start the debug session, choose **Project>Options>Debugger>FET Debugger>Setup>Enable ULP/LPMx.5 debug**.
- 2** Start the debugger.
- 3** Choose **C-SPY driver>Power Log Setup**. In the **ID** column, make sure to select the alternatives for which you want to enable power logging: **Current**, **Voltage**, or **Energy**.
- 4** Choose **C-SPY driver>Timeline** to open the **Timeline** window.
- 5** Right-click in the graph area and choose **Enable** from the context menu to enable the power graph you want to view. Repeat this for each graph you want to view.
- 6** Choose **C-SPY driver>Power Log** to open the **Power Log** window.
- 7** Optionally, if you want to correlate power values to the status of peripheral units, clocks, and CPU modes, right-click in the State Log graph area, and choose **Enable** from the context menu.
- 8** Optionally, before you start executing your application you can configure the viewing range of the Y-axis for the power graphs. See *Viewing Range dialog box*, page 222.

- 9 Click **Go** on the toolbar to start executing your application. In the **Power Log** window, all power values are displayed. In the **Timeline** window, you will see a graphical representation of the power values, and a graphical representation of the logged activity—state changes—for peripheral units and clocks, as well as CPU modes if you enabled the State Log graph. For information about how to navigate on the graph, see *Navigating in the graphs*, page 198.

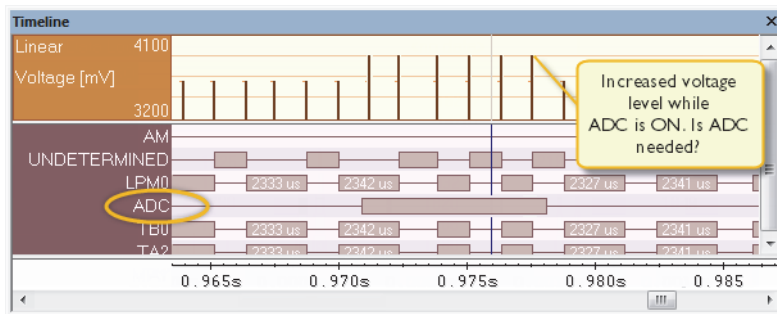

- 10 To analyze power consumption:

- Double-click on an interesting power value to highlight the corresponding source code in the editor window and in the **Disassembly** window. The corresponding log is highlighted in the **Power Log** window. For examples of when this can be useful, see *Optimizing your source code for power consumption*, page 243.
- You can identify peripheral units to disable if they are not used. You can detect this by analyzing the power graph in combination with the State Log Graph in the **Timeline** window. See also *Detecting mistakenly unattended peripherals*, page 245.

DISPLAYING THE POWER PROFILE ON A DEVICE WITHOUT ENERGYTRACE++

To view the power profile on a device without EnergyTrace++:

- 1 Start the debugger.
- 2 Choose **C-SPY driver>Power Log Setup**. In the **ID** column, make sure to select the alternatives for which you want to enable power logging: **Current**, **Voltage**, or **Energy**.
- 3 Choose **C-SPY driver>Timeline** to open the **Timeline** window.
- 4 Right-click in the graph area and choose **Enable** from the context menu to enable the power graph you want to view. Repeat this for each graph you want to view.
- 5 Choose **C-SPY driver>Power Log** to open the **Power Log** window.

- Click **Go** on the toolbar to start executing your application. In the **Power Log** window, all power values are displayed. In the **Timeline** window, you will see a graphical representation of the power values. For information about how to navigate on the graph, see *Navigating in the graphs*, page 198.

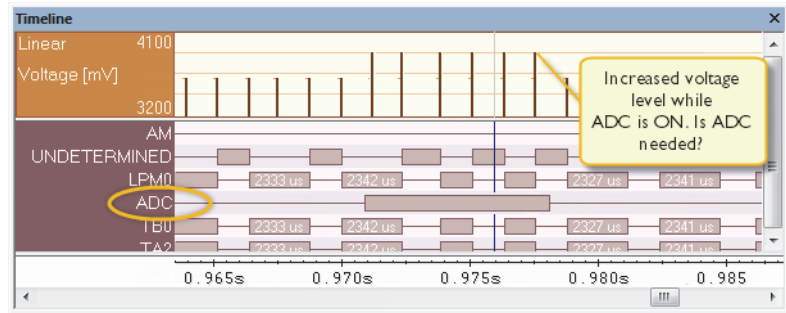

DETECTING UNEXPECTED POWER USAGE DURING APPLICATION EXECUTION

To detect unexpected power consumption on a device with EnergyTrace++:

- Choose **C-SPY driver>Power Log Setup** to open the **Power Log Setup** window.
- In the **Power Log Setup** window, specify a threshold value and the appropriate action, for example **Log All** and **Halt CPU Above Threshold**.
- Choose **C-SPY driver>Power Log** to open the **Power Log** window. If you continuously want to save the power values to a file, choose **Choose Live Log File** from the context menu. In this case you also need to choose **Enable Live Logging to**.
- Start the execution.

When the power consumption passes the threshold value, the execution will stop and perform the action you specified.

If you saved your logged power values to a file, you can open that file in an external tool for further analysis.

MEASURING LOW POWER CURRENTS

During the capture of the internal states or even when simply executing until a breakpoint stops the execution, the target microcontroller is constantly accessed via JTAG or Spy-Bi-Wire debug logic. These debug accesses consume energy that will be included in the numbers displayed in the **Power Log** window and graphs. To measure the power numbers of just the application, it is therefore recommended to use the

Release JTAG on Go option, which means that the debug logic of the target microcontroller is not accessed while measuring the power consumption.

To measure low power currents:

- 1 Before you start the debug session, choose **Project>Options>Debugger>FET Debugger>Setup>Enable ULP/LPMx.5 debug**.
- 2 Start the debugger.
- 3 Choose **C-SPY driver>Release JTAG on Go**.
- 4 Choose **C-SPY driver>Power Log Setup**. In the **ID** column, select the alternatives for which you want to enable power logging: **Current**, **Voltage**, or **Energy**.
- 5 To enable the graphs in the **Timeline** window, choose **Emulator>Timeline** to open the **Timeline** window. Right-click in the graph area for each graph that you have enabled power logging for and choose **Enable** from the context menu.
- 6 Start the execution.

Power logging is enabled and you can now see the graphs appear in the **Timeline** window.

CHANGING THE GRAPH RESOLUTION

To change the resolution of a Power graph in the Timeline window:

- 1 In the **Timeline** window, select the Power graph, right-click and choose **Open Setup Window** to open the **Power Log Setup** window.
- 2 From the context menu in the **Power Log Setup** window, choose a suitable unit of measurement.
- 3 In the **Timeline** window, select the Power graph, right-click and choose **Viewing Range** from the context menu.
- 4 In the **Viewing Range** dialog box, select **Custom** and specify range values in the **Lowest value** and the **Highest value** text boxes. Click **OK**.
- 5 The graph is automatically updated accordingly.

Reference information on power debugging

Reference information about:

- *Power Log Setup window*, page 252
- *Power Log window*, page 254
- *Timeline window—Power graph*, page 257

- *State Log Setup window*, page 258
- *State Log window*, page 259
- *State Log Summary window*, page 261
- *Timeline window—State Log graph*, page 264

See also:

- *Trace window*, page 184
- *The application timeline*, page 195
- *Viewing Range dialog box*, page 222
- *Function Profiler window*, page 230

Power Log Setup window

The **Power Log Setup** window is available from the C-SPY driver menu during a debug session.

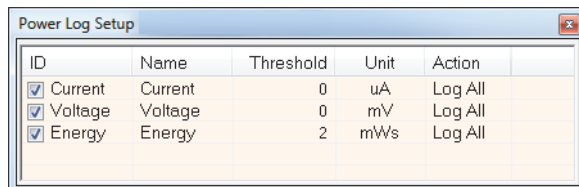

ID	Name	Threshold	Unit	Action
<input checked="" type="checkbox"/>	Current	0	uA	Log All
<input checked="" type="checkbox"/>	Voltage	0	mV	Log All
<input checked="" type="checkbox"/>	Energy	2	mWs	Log All

Use this window to configure the power measurement.

Note: To enable power logging, choose **Enable** from the context menu in the **Power Log** window or from the context menu in the power graph in the **Timeline** window.

Requirements

An eZFET or MSP-FET debug probe.

Display area

This area contains these columns:

ID

A unique string that identifies the measurement channel in the probe. Select the check box to activate the channel. If the check box is deselected, logs will not be generated for that channel.

Name

Specify a user-defined name.

Threshold

Specify a threshold value in the selected unit. The action you specify will be executed when the threshold value is reached.

Unit

Displays the selected unit for power. You can choose a unit from the context menu.

Action

Displays the selected action for the measurement channel. Choose between:

- **Log All**
- **Log Above Threshold**
- **Log Below Threshold**
- **Log All and Halt CPU Above Threshold**
- **Log All and Halt CPU Below Threshold**

Context menu

This context menu is available:

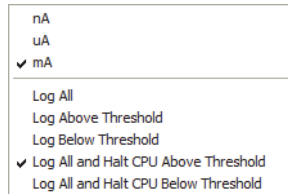

These commands are available:

nA, uA, mA

Selects the unit for the power display. These alternatives are available for channels that measure current.

uV, mV, V

Selects the unit for power display. These alternatives are available for channels that measure voltage.

uWs, mWs, Ws

Selects the unit for power display. These alternatives are available for channels that measure energy.

Log All

Logs all values.

Log Above Threshold

Logs all values above the threshold.

Log Below Threshold

Logs all values below the threshold.

Log All and Halt CPU Above Threshold

Logs all values. If a logged value exceeds the threshold, execution is stopped. This might take a few execution cycles.

Log All and Halt CPU Below Threshold

Logs all values. If a logged value goes below the threshold, execution is stopped. This might take a few execution cycles.

Power Log window

The **Power Log** window is available from the C-SPY driver menu during a debug session.

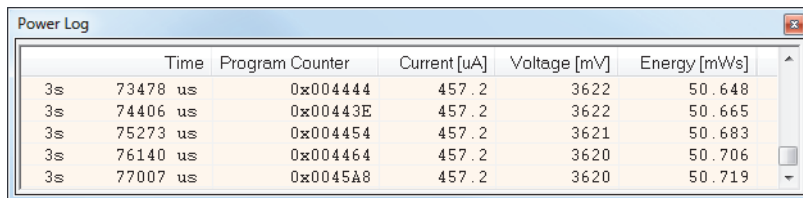

	Time	Program Counter	Current [uA]	Voltage [mV]	Energy [mWs]
3s	73478 us	0x004444	457.2	3622	50.648
3s	74406 us	0x00443E	457.2	3622	50.665
3s	75273 us	0x004454	457.2	3621	50.683
3s	76140 us	0x004464	457.2	3620	50.706
3s	77007 us	0x0045A8	457.2	3620	50.719

This window displays collected power values.

A row with only Time/Cycles and Program Counter displayed in gray denotes a logged power value for a channel that was active during the actual collection of data but currently is disabled in the **Power Log Setup** window.

Note: The number of logged power values is limited. When this limit is exceeded, the oldest entries in the buffer are erased.

Requirements

An eZFET or MSP-FET debug probe.

Display area

This area contains these columns:

Time

The time from the application reset until the event, based on time stamps.

This column is available when you have selected **Show Time** from the context menu.

Program Counter (J-Link only)

Displays one of these:

An address, which is the content of the PC, that is, the address of an instruction close to where the power value was collected.

---, the target system failed to provide the debugger with any information.

Overflow in red, the communication channel failed to transmit all data from the target system.

Note that the **Program Counter** column is only available if your device supports it.

Name [*unit*]

The power measurement value expressed in the unit you specified in the **Power Log Setup** window.

Context menu

This context menu is available:

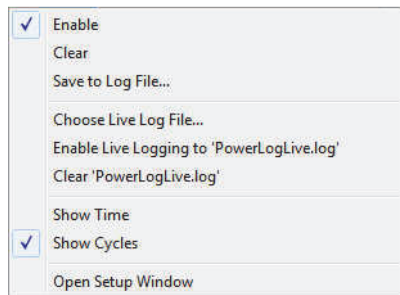

These commands are available:

Enable

Enables the logging system, which means that power values are saved internally within the IDE. The values are displayed in the **Power Log** window and in the Power graph in the **Timeline** window (if enabled). The system will log information also when the window is closed.

Clear

Deletes the log information. Note that this will also happen when you reset the debugger.

Save to File

Displays a standard file selection dialog box where you can select the destination file for the log information. The entries in the log file are separated by `TAB` and `LF` characters. An **X** in the **Approx** column indicates that the timestamp is an approximation.

Choose Live Log File

Displays a standard file selection dialog box where you can choose a destination file for the logged power values. The power values are continuously saved to that file during execution. The content of the live log file is never automatically cleared, the logged values are simply added at the end of the file.

Enable Live Logging to

Toggles live logging on or off. The logs are saved in the specified file.

Clear *log file*

Clears the content of the live log file.

Show Time

Displays the **Time** column.

If the **Time** column is displayed by default in the C-SPY driver you are using, this menu command is not available.

Show Cycles

Displays the **Cycles** column.

If the **Cycles** column is not supported in the C-SPY driver you are using, this menu command is not available.

Open Setup Window

Opens the **Power Log Setup** window.

The format of the log file

The log file has a tab-separated format. The entries in the log file are separated by `TAB` and line feed. The logged power values are displayed in these columns:

Time/Cycles

The time from the application reset until the power value was logged.

Approx

An **x** in the column indicates that the power value has an approximative value for time/cycle.

PC

The value of the program counter close to the point where the power value was logged.

Name [unit]

The corresponding value from the **Power Log** window, where *Name* and *unit* are according to your settings in the **Power Log Setup** window.

Timeline window—Power graph

The power graph in the **Timeline** window is available from the C-SPY driver menu during a debug session.

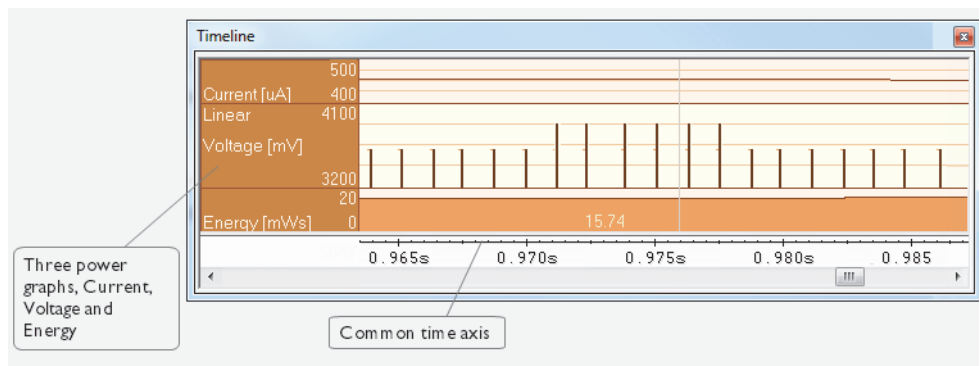

The power graph displays a graphical view of power measurement samples.

Depending on the abilities in hardware, the debug probe, and the C-SPY driver you are using, this window can display a Power Log graph that shows power measurement samples generated by the debug probe or associated hardware in relation to a common time axis.

For more information about the **Timeline** window, how to display a graph, and the other supported graphs, see *Reference information on application timeline*, page 201.

See also *Requirements and restrictions for power debugging*, page 243.

Requirements

An eZFET or MSP-FET debug probe.

Display area

Where:

- The label area at the left end of the graph displays the name of the measurement channel.
- The Voltage and the Current graphs show power measurement samples generated by the debug probe or associated hardware. The Energy graph shows accumulated energy since the last time the CPU was stopped.
- The graphs can be displayed as a thin line between consecutive logs, as a rectangle for every log (optionally color-filled), or as columns.
- The resolution of the graphs can be changed.

At the bottom of the window, there is a common time axis that uses seconds as the time unit.

State Log Setup window

The **State Log Setup** window is available from the menu during a debug session.

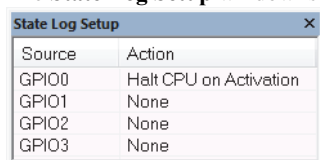

Source	Action
GPIO0	Halt CPU on Activation
GPIO1	None
GPIO2	None
GPIO3	None

Use the **State Log Setup** window to specify whether to halt the CPU in connection with activity—state changes—for peripheral units and clocks, as well as for CPU modes.

State Log window

The **State Log** window is available from the C-SPY driver menu.

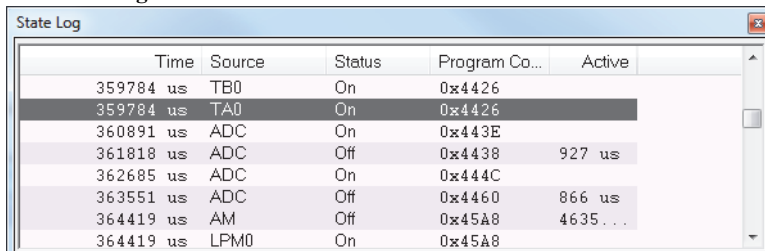

Time	Source	Status	Program Co...	Active
359784 us	TB0	On	0x4426	
359784 us	TA0	On	0x4426	
360891 us	ADC	On	0x443E	
361818 us	ADC	Off	0x4438	927 us
362685 us	ADC	On	0x444C	
363551 us	ADC	Off	0x4460	866 us
364419 us	AM	Off	0x45A8	4635...
364419 us	LPM0	On	0x45A8	

This window logs activity—state changes—for peripheral units and clocks, as well as for CPU modes.

The information is useful for tracing the activity on the target system. When the **State Log** window is open, it is updated continuously at runtime.

Note: There is a limit on the number of saved logs. When this limit is exceeded, the oldest entries in the buffer are erased.

See also *Displaying a power profile and analyzing the result*, page 248 and *Timeline window—State Log graph*, page 264.

Requirements

An MSP430 device with JSTATE register and an eZFET or MSP-FET debug probe.

Display area

This area contains these columns:

Time

The time for the state change, based on the sampling frequency.

If a time is displayed in italics, the target system has not been able to collect a correct time, but instead had to approximate it.

Source

The name of the peripheral unit, clock, or CPU mode.

Status

The status at the given time.

Program Counter*

The address of the program counter when the status changed, or shows **idle** if the log was taken during CPU idle mode, or shows --- for an unknown PC value.

Active

The active time calculated using the on and off time for the source. If it is written in italics, it is based on at least one approximative time.

* You can double-click an address. If it is available in the source code, the editor window displays the corresponding source code, for example for the interrupt handler (this does not include library source code).

Context menu

This context menu is available:

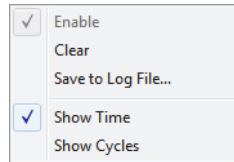

These commands are available:

Enable

Enables the logging system. The system will log information also when the window is closed.

Clear

Deletes the log information. Note that this will also happen when you reset the debugger.

Save to File

Displays a standard file selection dialog box where you can select the destination file for the log information. The entries in the log file are separated by `TAB` and `LF` characters. An **X** in the **Approx** column indicates that the timestamp is an approximation.

Show Time

Displays the **Time** column.

If the **Time** column is always displayed by default in the C-SPY driver you are using, this menu command is not available.

Show Cycles

Displays the **Cycles** column.

If the C-SPY driver you are using does not support the **Cycles** column, this menu command is not available.

State Log Summary window

The **State Log Summary** window is available from the C-SPY driver menu.

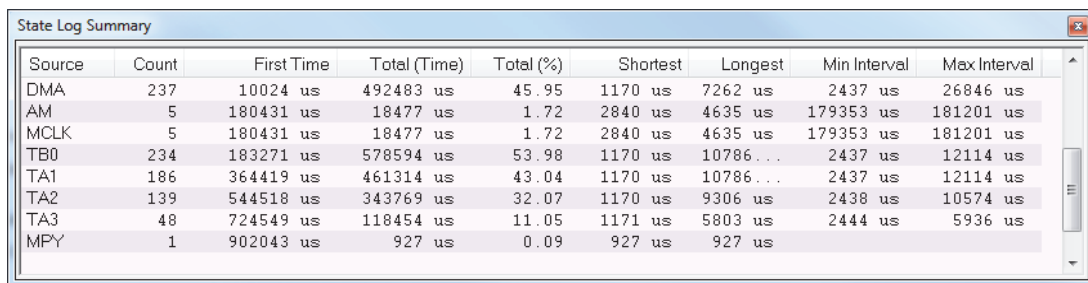

Source	Count	First Time	Total (Time)	Total (%)	Shortest	Longest	Min Interval	Max Interval
DMA	237	10024 us	492483 us	45.95	1170 us	7262 us	2437 us	26846 us
AM	5	180431 us	18477 us	1.72	2840 us	4635 us	179353 us	181201 us
MCLK	5	180431 us	18477 us	1.72	2840 us	4635 us	179353 us	181201 us
TB0	234	183271 us	578594 us	53.98	1170 us	10786 ...	2437 us	12114 us
TA1	186	364419 us	461314 us	43.04	1170 us	10786 ...	2437 us	12114 us
TA2	139	544518 us	343769 us	32.07	1170 us	9306 us	2438 us	10574 us
TA3	48	724549 us	118454 us	11.05	1171 us	5803 us	2444 us	5936 us
MPY	1	902043 us	927 us	0.09	927 us	927 us		

This window displays a summary of logged activity—state changes—for peripheral units and clocks, as well as for CPU modes.

Click a column to sort it according to the values. Click again to reverse the sort order.

At the bottom of the display area, the current time or cycles is displayed—the number of cycles or the execution time since the start of execution.

See also *Displaying a power profile and analyzing the result*, page 248 and *Timeline window—State Log graph*, page 264.

Requirements

An MSP430 device with JSTATE register and an eZFET or MSP-FET debug probe.

Display area

Each row in this area displays statistics about the specific measurement source based on the log information in these columns; and summary information is listed at the bottom of the display area:

Source

The name of the peripheral unit, clock, or CPU mode.

Count

The number of times the source was activated.

First time

The first time the source was activated.

Total (Time)**

The accumulated time the source has been active.

Total (%)

The accumulated time in percent that the source has been active.

Shortest

The shortest time spent with this source active.

Longest

The longest time spent with this source active.

Min interval

The shortest time between two activations of this source.

Max interval

The longest time between two activations of this source.

Approximative time count

The information displayed depends on the C-SPY driver you are using.

For some C-SPY drivers, this information is not displayed or the value is always zero. In this case, all logs have an exact time stamp.

For other C-SPY drivers, a non-zero value is displayed. The value represents the amount of logs with an approximative time stamp. This might happen if the bandwidth in the communication channel is too low compared to the amount of data packets generated by the CPU or if the CPU generated packets with an approximative time stamp.

Overflow count

The information displayed depends on the C-SPY driver you are using.

For some C-SPY drivers, this information is not displayed or the value is always zero.

For other C-SPY drivers, the number represents the amount of overflows in the communication channel which can cause logs to be lost. If this happens, it indicates that logs might be incomplete. To solve this, make sure not to use all C-SPY log features simultaneously or check used bandwidth for the communication channel.

Current time**/Current cycles**

The information displayed depends on the C-SPY driver you are using.

For some C-SPY drivers, the value is always zero or not visible at all.

For other C-SPY drivers, the number represents the current time or cycles—the number of cycles or the execution time since the start of execution.

** Calculated in the same way as for the Execution time/cycles in the **State Log** window.

Context menu

This context menu is available:

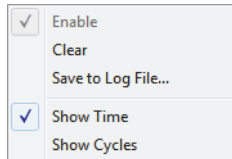

These commands are available:

Enable

Enables the logging system. The system will log information also when the window is closed.

Clear

Deletes the log information. Note that this will also happen when you reset the debugger.

Save to File

Displays a standard file selection dialog box where you can select the destination file for the log information. The entries in the log file are separated by `TAB` and `LF` characters. An **X** in the **Approx** column indicates that the timestamp is an approximation.

Show Time

Displays the **Time** column.

If the **Time** column is always displayed by default in the C-SPY driver you are using, this menu command is not available.

Show Cycles

Displays the **Cycles** column.

If the C-SPY driver you are using does not support the **Cycles** column, this menu command is not available.

Timeline window—State Log graph

The State Log graph in the **Timeline** window is available from the C-SPY driver menu during a debug session.

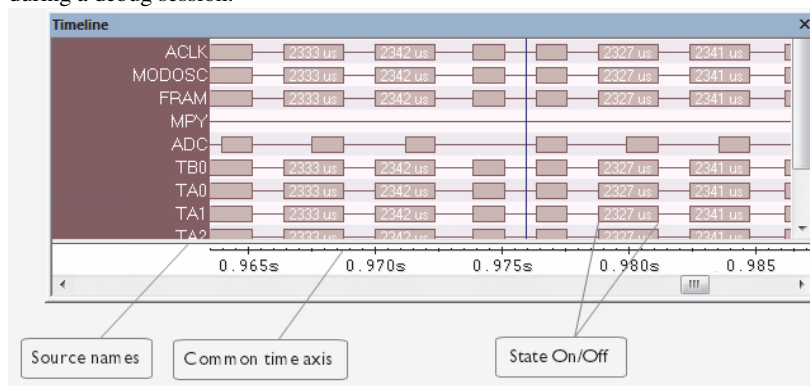

The **State Log** graph displays a graphical view of logged activity—state changes—for peripheral units and clocks, as well as CPU modes in relation to a common time axis.

Note: There is a limit on the number of saved logs. When this limit is exceeded, the oldest entries in the buffer are erased.

For more information about the **Timeline** window, how to display a graph, and the other supported graphs, see *Reference information on application timeline*, page 201.

See also *Requirements and restrictions for power debugging*, page 243.

Requirements

An MSP430 device with JSTATE register and an eZFET or MSP-FET debug probe.

Display area

Where:

- The label area at the left end of the graph displays the name of the sources of the status information.
- The graph itself shows the state of the peripheral units, clocks, and CPU modes generated by the debug probe or associated hardware. The white figure indicates the time spent in the state. This graph is a graphical representation of the information in the **State Log** window, see *State Log window*, page 259.

At the bottom of the window, there is a shared time axis that uses seconds as the time unit.

Part 3. Advanced debugging

This part of the *C-SPY® Debugging Guide for MSP430* includes these chapters:

- Interrupts
- The advanced cycle counter
- State storage
- The sequencer
- C-SPY macros
- The C-SPY command line utility—`cspybat`

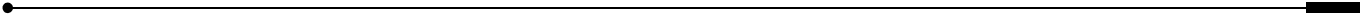
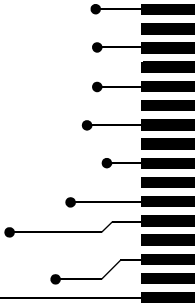

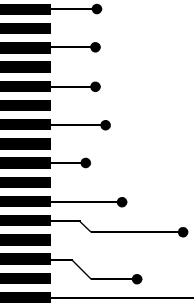

Interrupts

- Introduction to interrupts
- Using the interrupt system
- Reference information on interrupts

Introduction to interrupts

These topics are covered:

- Briefly about the interrupt simulation system
- Interrupt characteristics
- Interrupt simulation states
- C-SPY system macros for interrupt simulation
- Target-adapting the interrupt simulation system
- Briefly about interrupt logging

See also:

- *Reference information on C-SPY system macros*, page 325
- *Breakpoints*, page 107
- *The IAR C/C++ Compiler User Guide for MSP430*

BRIEFLY ABOUT THE INTERRUPT SIMULATION SYSTEM

By simulating interrupts, you can test the logic of your interrupt service routines and debug the interrupt handling in the target system long before any hardware is available. If you use simulated interrupts in conjunction with C-SPY macros and breakpoints, you can compose a complex simulation of, for instance, interrupt-driven peripheral devices.

The C-SPY Simulator includes an interrupt simulation system where you can simulate the execution of interrupts during debugging. You can configure the interrupt simulation system so that it resembles your hardware interrupt system.

The interrupt system has the following features:

- Simulated interrupt support for the MSP430 microcontroller
- Single-occasion or periodical interrupts based on the cycle counter
- Predefined interrupts for various devices

- Configuration of hold time, probability, and timing variation
- State information for locating timing problems
- Configuration of interrupts using a dialog box or a C-SPY system macro—that is, one interactive and one automating interface. In addition, you can instantly force an interrupt.
- A log window that continuously displays events for each defined interrupt.
- A status window that shows the current interrupt activities.

All interrupts you define using the **Interrupt Setup** dialog box are preserved between debug sessions, unless you remove them. A forced interrupt, on the other hand, exists only until it has been serviced and is not preserved between sessions.



The interrupt simulation system is activated by default, but if not required, you can turn off the interrupt simulation system to speed up the simulation. To turn it off, use either the **Interrupt Setup** dialog box or a system macro.

INTERRUPT CHARACTERISTICS

The simulated interrupts consist of a set of characteristics which lets you fine-tune each interrupt to make it resemble the real interrupt on your target hardware. You can specify a *first activation time*, a *repeat interval*, a *hold time*, a *variance*, and a *probability*.

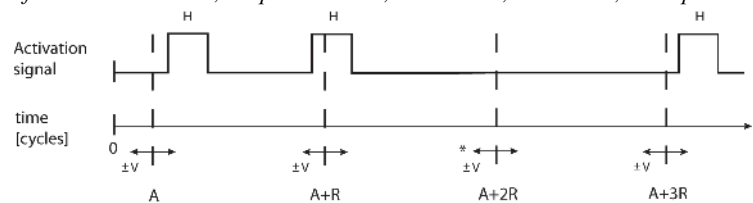

* If probability is less than 100%, some interrupts may be omitted.

A = Activation time
R = Repeat interval
H = Hold time
V = Variance

The interrupt simulation system uses the cycle counter as a clock to determine when an interrupt should be raised in the simulator. You specify the *first activation time*, which is based on the cycle counter. C-SPY will generate an interrupt when the cycle counter has passed the specified activation time. However, interrupts can only be raised between instructions, which means that a full assembler instruction must have been executed before the interrupt is generated, regardless of how many cycles an instruction takes.

To define the periodicity of the interrupt generation you can specify the *repeat interval* which defines the amount of cycles after which a new interrupt should be generated. In addition to the repeat interval, the periodicity depends on the two options *probability*—

the probability, in percent, that the interrupt will actually appear in a period—and *variance*—a time variation range as a percentage of the repeat interval. These options make it possible to randomize the interrupt simulation. You can also specify a *hold time* which describes how long the interrupt remains pending until removed if it has not been processed. If the hold time is set to *infinite*, the corresponding pending bit will be set until the interrupt is acknowledged or removed.

INTERRUPT SIMULATION STATES

The interrupt simulation system contains status information that you can use for locating timing problems in your application. The **Interrupt Status** window displays the available status information. For an interrupt, these states can be displayed: *Idle*, *Pending*, *Executing*, or *Suspended*.

Normally, a repeatable interrupt has a specified repeat interval that is longer than the execution time. In this case, the status information at different times looks like this:

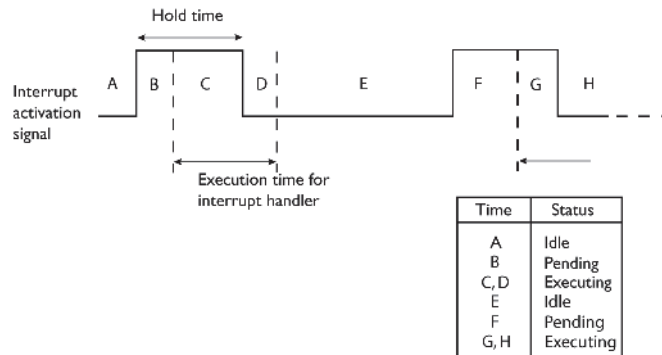

Note: The interrupt activation signal—also known as the pending bit—is automatically deactivated the moment the interrupt is acknowledged by the interrupt handler.

However, if the interrupt repeat interval is shorter than the execution time, and the interrupt is reentrant (or non-maskable), the status information at different times looks like this:

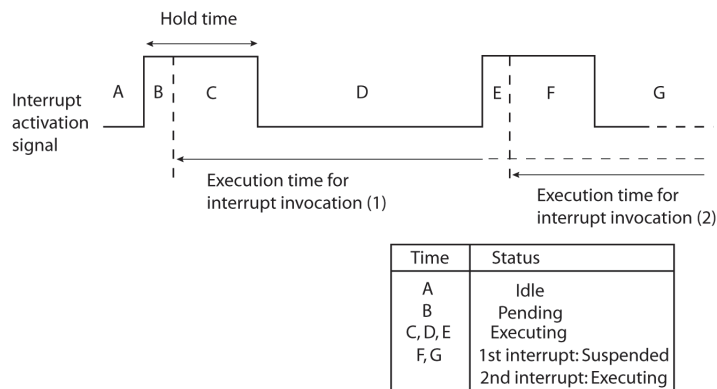

An execution time that is longer than the repeat interval might indicate that you should rewrite your interrupt handler and make it faster, or that you should specify a longer repeat interval for the interrupt simulation system.

C-SPY SYSTEM MACROS FOR INTERRUPT SIMULATION

Macros are useful when you already have sorted out the details of the simulated interrupt so that it fully meets your requirements. If you write a macro function containing definitions for the simulated interrupts, you can execute the functions automatically when C-SPY starts. Another advantage is that your simulated interrupt definitions will be documented if you use macro files, and if you are several engineers involved in the development project you can share the macro files within the group.

The C-SPY Simulator provides these predefined system macros related to interrupts:

- `__cancelAllInterrupts`
- `__cancelInterrupt`
- `__disableInterrupts`
- `__enableInterrupts`
- `__orderInterrupt`
- `__popSimulatorInterruptExecutingStack`

The parameters of the first five macros correspond to the equivalent entries of the **Interrupt Setup** dialog box.

For more information about each macro, see *Reference information on C-SPY system macros*, page 325.

TARGET-ADAPTING THE INTERRUPT SIMULATION SYSTEM

The interrupt simulation system is easy to use. However, to take full advantage of the interrupt simulation system you should be familiar with how to adapt it for the processor you are using.

The interrupt simulation has the same behavior as the hardware. This means that the execution of an interrupt is dependent on the status of the global interrupt enable bit. The execution of maskable interrupts is also dependent on the status of the individual interrupt enable bits.

To simulate device-specific interrupts, the interrupt system must have detailed information about each available interrupt. This information is provided in the device description files.

For information about device description files, see *Selecting a device description file*, page 44.

BRIEFLY ABOUT INTERRUPT LOGGING

Interrupt logging provides you with comprehensive information about the interrupt events. This might be useful, for example, to help you locate which interrupts you can fine-tune to become faster. You can log entrances and exits to and from interrupts. You can also log internal interrupt status information, such as triggered, expired, etc. In the IDE:

- The logs are displayed in the **Interrupt Log** window
- A summary is available in the **Interrupt Log Summary** window
- The Interrupt graph in the **Timeline** window provides a graphical view of the interrupt events during the execution of your application

Requirements for interrupt logging

Interrupt logging is supported by the C-SPY simulator.

See also *Getting started using interrupt logging*, page 274.

Using the interrupt system

These tasks are covered:

- Simulating a simple interrupt
- Simulating an interrupt in a multi-task system
- Getting started using interrupt logging

See also:

- *Using C-SPY macros*, page 313 for details about how to use a setup file to define simulated interrupts at C-SPY startup
- The tutorial *Simulating an interrupt* in the Information Center.

SIMULATING A SIMPLE INTERRUPT

This example demonstrates the method for simulating a timer interrupt. However, the procedure can also be used for other types of interrupts.

To simulate and debug an interrupt:

- 1 Assume this simple application which contains an interrupt service routine for the BasicTimer, which increments a tick variable. The main function sets the necessary status registers. The application exits when 100 interrupts have been generated.

```
#include "io430x41x.h"
#include <intrinsics.h>

volatile int ticks = 0;
void main (void)
{
    /* Timer setup code */
    WDTCTL = WDTPW + WDTHOLD;    /* Stop WDT */
    IE2 |= BTIE;                /* Enable BT interrupt */
    BTCTL = BTSSEL+BTIP2+BTIP1+BTIP0;
    __enable_interrupt();       /* Enable interrupts */

    while (ticks < 100);        /* Endless loop */
    printf("Done\n");
}

/* Timer interrupt service routine */
#pragma vector = BASICTIMER_VECTOR
__interrupt void basic_timer(void)
{
    ticks += 1;
}
```

- 2 Add your interrupt service routine to your application source code and add the file to your project.
- 3 Choose **Project>Options>Debugger>Setup**, select **Override default**, and choose a device description file. The device description file contains information about the interrupt that C-SPY needs to be able to simulate it. Use the browse button to locate the ddf file.
- 4 Build your project and start the simulator.

- 5 Choose **Simulator>Interrupt Setup** to open the **Interrupts Setup** dialog box. Select **Enable interrupt simulation** to enable interrupt simulation. Click **New** to open the **Edit Interrupt** dialog box. For the timer example, verify these settings:

Option	Settings
Interrupt	BASICTIMER_VECTOR
First activation	4000
Repeat interval	2000
Hold time	10
Probability (%)	100
Variance (%)	0

Table 12: Timer interrupt settings

Click **OK**.

- 6 Execute your application. If you have enabled the interrupt properly in your application source code, C-SPY will:
- Generate an interrupt when the cycle counter has passed 4000
 - Continuously repeat the interrupt after approximately 2000 cycles.
- 7 To watch the interrupt in action, choose **Simulator>Interrupt Log** to open the **Interrupt Log** window.
- 8 From the context menu, available in the **Interrupt Log** window, choose **Enable** to enable the logging. If you restart program execution, status information about entrances and exits to and from interrupts will now appear in the **Interrupt Log** window.

For information about how to get a graphical representation of the interrupts correlated with a time axis, see *Reference information on application timeline*, page 201.

SIMULATING AN INTERRUPT IN A MULTI-TASK SYSTEM

If you are using interrupts in such a way that the normal instruction used for returning from an interrupt handler is not used, for example in an operating system with task-switching, the simulator cannot automatically detect that the interrupt has finished executing. The interrupt simulation system will work correctly, but the status information in the **Interrupt Setup** dialog box might not look as you expect. If too many interrupts are executing simultaneously, a warning might be issued.

To simulate a normal interrupt exit:

- 1 Set a code breakpoint on the instruction that returns from the interrupt function.

- 2 Specify the `__popSimulatorInterruptExecutingStack` macro as a condition to the breakpoint.

When the breakpoint is triggered, the macro is executed and then the application continues to execute automatically.

GETTING STARTED USING INTERRUPT LOGGING

- 1 Choose *C-SPY driver*>**Interrupt Log** to open the **Interrupt Log** window. Optionally, you can also choose:
 - *C-SPY driver*>**Interrupt Log Summary** to open the **Interrupt Log Summary** window
 - *C-SPY driver*>**Timeline** to open the **Timeline** window and view the Interrupt graph
- 2 From the context menu in the **Interrupt Log** window, choose **Enable** to enable the logging.
- 3 Start executing your application program to collect the log information.
- 4 To view the interrupt log information, look in the **Interrupt Log** or **Interrupt Log Summary** window, or the Interrupt graph in the **Timeline** window.
- 5 If you want to save the log or summary to a file, choose **Save to log file** from the context menu in the window in question.
- 6 To disable interrupt logging, from the context menu in the **Interrupt Log** window, toggle **Enable** off.

Reference information on interrupts

Reference information about:

- *Interrupt Setup dialog box*, page 275
- *Edit Interrupt dialog box*, page 277
- *Forced Interrupt window*, page 278
- *Interrupt Status window*, page 279
- *Interrupt Log window*, page 281
- *Interrupt Log Summary window*, page 284
- *Timeline window—Interrupt Log graph*, page 287

Interrupt Setup dialog box

The **Interrupt Setup** dialog box is available by choosing **Simulator>Interrupt Setup**.

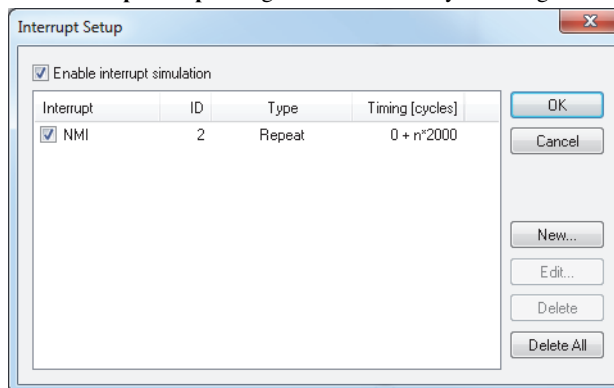

This dialog box lists all defined interrupts. Use this dialog box to enable or disable the interrupt simulation system, as well as to enable or disable individual interrupts.

See also *Using the interrupt system*, page 271.

Requirements

The C-SPY simulator.

Enable interrupt simulation

Enables or disables interrupt simulation. If the interrupt simulation is disabled, the definitions remain but no interrupts are generated. Note that you can also enable and disable installed interrupts individually by using the check box to the left of the interrupt name in the list of installed interrupts.

Display area

This area contains these columns:

Interrupt

Lists all interrupts. Use the checkbox to enable or disable the interrupt.

ID

A unique interrupt identifier.

Type

Shows the type of the interrupt. The type can be one of:

Forced, a single-occasion interrupt defined in the **Forced Interrupt** window.

Single, a single-occasion interrupt.

Repeat, a periodically occurring interrupt.

If the interrupt has been set from a C-SPY macro, the additional part (**macro**) is added, for example: **Repeat(macro)**.

Timing

The timing of the interrupt. For a **Single** and **Forced** interrupt, the activation time is displayed. For a **Repeat** interrupt, the information has the form: `Activation Time + n*Repeat Time`. For example, `2000 + n*2345`. This means that the first time this interrupt is triggered, is at 2000 cycles and after that with an interval of 2345 cycles.

Buttons

These buttons are available:

New

Opens the **Edit Interrupt** dialog box, see *Edit Interrupt dialog box*, page 277.

Edit

Opens the **Edit Interrupt** dialog box, see *Edit Interrupt dialog box*, page 277.

Delete

Removes the selected interrupt.

Delete All

Removes all interrupts.

Edit Interrupt dialog box

The **Edit Interrupt** dialog box is available from the **Interrupt Setup** dialog box.

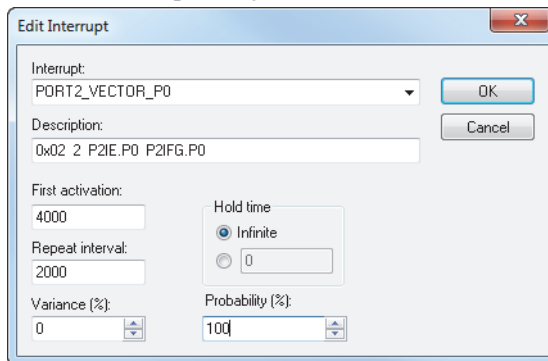

Use this dialog box to interactively fine-tune the interrupt parameters. You can add the parameters and quickly test that the interrupt is generated according to your needs.

Note: You can only edit or remove non-forced interrupts.

See also *Using the interrupt system*, page 271.

Requirements

The C-SPY simulator.

Interrupt

Selects the interrupt that you want to edit. The drop-down list contains all available interrupts. Your selection will automatically update the **Description** box. The list is populated with entries from the device description file that you have selected.

Description

A description of the selected interrupt, if available. The description is retrieved from the selected device description file and consists of a string describing the vector address, the default priority, enable bit, and pending bit, separated by space characters. For interrupts specified using the system macro `__orderInterrupt`, the **Description** box is empty.

First activation

Specify the value of the cycle counter after which the specified type of interrupt will be generated.

Repeat interval

Specify the periodicity of the interrupt in cycles.

Variance %

Selects a timing variation range, as a percentage of the repeat interval, in which the interrupt might occur for a period. For example, if the repeat interval is 100 and the variance 5%, the interrupt might occur anywhere between $T=95$ and $T=105$, to simulate a variation in the timing.

Hold time

Specify how long, in cycles, the interrupt remains pending until removed if it has not been processed. If you select **Infinite**, the corresponding pending bit will be set until the interrupt is acknowledged or removed.

Probability %

Selects the probability, in percent, that the interrupt will actually occur within the specified period.

Forced Interrupt window

The **Forced Interrupt** window is available from the C-SPY driver menu.

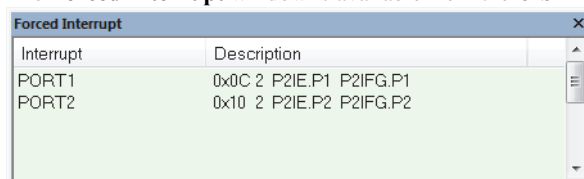

Interrupt	Description
PORT1	0x0C 2 P2IE.P1 P2IFG.P1
PORT2	0x10 2 P2IE.P2 P2IFG.P2

Use this window to force an interrupt instantly. This is useful when you want to check your interrupt logic and interrupt routines. Just start typing an interrupt name and focus shifts to the first line found with that name.

The hold time for a forced interrupt is infinite, and the interrupt exists until it has been serviced or until a reset of the debug session.

To sort the window contents, click on either the **Interrupt** or the **Description** column header. A second click on the same column header reverses the sort order.

To force an interrupt:

- 1 Enable the interrupt simulation system, see *Interrupt Setup dialog box*, page 275.
- 2 Double-click the interrupt in the **Forced Interrupt** window, or activate it by using the **Force** command available on the context menu.

Requirements

The C-SPY simulator.

Display area

This area lists all available interrupts and their definitions. The description field is editable and the information is retrieved from the selected device description file. See this file for a detailed description.

Context menu

This context menu is available:

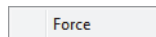

This command is available:

Force

Triggers the interrupt you selected in the display area.

Interrupt Status window

The **Interrupt Status** window is available from the C-SPY driver menu.

Interrupt	ID	Type	Status	Next Time	Timing [cycles]
TIM_INT	1	Single	Idle	0	0
NMI	0	Single	Idle	0	0
SCIO_I0	2	Repeat (macro)	Idle	4000	4000 + n*2000

This window shows the status of all the currently active interrupts, in other words interrupts that are either executing or waiting to be executed.

Requirements

The C-SPY simulator.

Display area

This area contains these columns:

Interrupt

Lists all interrupts.

ID

A unique interrupt identifier.

Type

The type of the interrupt. The type can be one of:

Forced, a single-occasion interrupt defined in the **Forced Interrupt** window.

Single, a single-occasion interrupt.

Repeat, a periodically occurring interrupt.

If the interrupt has been set from a C-SPY macro, the additional part (**macro**) is added, for example: **Repeat(macro)**.

Status

The state of the interrupt:

Idle, the interrupt activation signal is low (deactivated).

Pending, the interrupt activation signal is active, but the interrupt has not been yet acknowledged by the interrupt handler.

Executing, the interrupt is currently being serviced, that is the interrupt handler function is executing.

Suspended, the interrupt is currently suspended due to execution of an interrupt with a higher priority.

(deleted) is added to **Executing** and **Suspended** if you have deleted a currently active interrupt. **(deleted)** is removed when the interrupt has finished executing.

Next Time

The next time an idle interrupt is triggered. Once a repeatable interrupt starts executing, a copy of the interrupt will appear with the state Idle and the next time set. For interrupts that do not have a next time—that is pending, executing, or suspended—the column will show --.

Timing

The timing of the interrupt. For a **Single** and **Forced** interrupt, the activation time is displayed. For a **Repeat** interrupt, the information has the form: $\text{Activation Time} + n * \text{Repeat Time}$. For example, $2000 + n * 2345$. This means that the first time this interrupt is triggered, is at 2000 cycles and after that with an interval of 2345 cycles.

Interrupt Log window

The **Interrupt Log** window is available from the C-SPY driver menu.

Time	Interrupt	Status	Program Counter	Execution Time
109.32 us	IRQ0	Triggered	0x13E8	
111.26 us	IRQ0	Enter	0x13F0	
135.78 us	IRQ1	Enter	0x1126	
148.72 us	IRQ1	Leave	0x1378	12.94 us
<i>189.34 us</i>	<i>Overflow</i>			
207.30 us	IRQ0	Leave	0x1126	96.04 us
230.00 us	IRQ0	Triggered	0x1110	
231.34 us	IRQ0	Enter	0x1126	
240.26 us	IRQ0	Leave	0x1122	8.92 us
300.00 us	IRQ1	Enter	---	
371.12 us	IRQ1	Leave	0x1120	71.12 us
431.30 us	IRQ1	Enter	---	

Red indicates overflows and italic indicates approximate values

Light-colored rows indicate entrances to interrupts

Darker rows indicate exits from interrupts

This window logs entrances to and exits from interrupts. The C-SPY simulator also logs internal state changes.

The information is useful for debugging the interrupt handling in the target system. When the **Interrupt Log** window is open, it is updated continuously at runtime.

Note: There is a limit on the number of saved logs. When this limit is exceeded, the oldest entries in the buffer are erased.

For more information, see *Getting started using interrupt logging*, page 274.

For information about how to get a graphical view of the interrupt events during the execution of your application, see *Timeline window—Interrupt Log graph*, page 287.

Requirements

The C-SPY simulator.

Display area

This area contains these columns:

Time

The point in time, measured in seconds, when the event occurred.

This column is available when you have selected **Show Time** from the context menu.

Cycles

The number of cycles from the start of the execution until the event.

This column is available when you have selected **Show Cycles** from the context menu.

Interrupt

The interrupt as defined in the device description file.

Status

Shows the event status of the interrupt:

Triggered, the interrupt has passed its activation time.

Forced, the same as Triggered, but the interrupt was forced from the **Forced Interrupt** window.

Enter, the interrupt is currently executing.

Leave, the interrupt has been executed.

Expired, the interrupt hold time has expired without the interrupt being executed.

Rejected, the interrupt has been rejected because the necessary interrupt registers were not set up to accept the interrupt.

Program Counter

The value of the program counter when the event occurred.

Execution Time/Cycles

The time spent in the interrupt, calculated using the Enter and Leave timestamps. This includes time spent in any subroutines or other interrupts that occurred in the specific interrupt.

Context menu

This context menu is available:

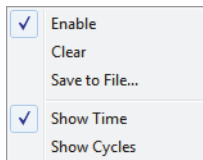

These commands are available:

Enable

Enables the logging system. The system will log information also when the window is closed.

Clear

Deletes the log information. Note that this will also happen when you reset the debugger.

Save to File

Displays a standard file selection dialog box where you can select the destination file for the log information. The entries in the log file are separated by `TAB` and `LF` characters. An **X** in the **Approx** column indicates that the timestamp is an approximation.

Show Time

Displays the **Time** column.

If the **Time** column is displayed by default in the C-SPY driver you are using, this menu command is not available.

Show Cycles

Displays the **Cycles** column.

If the **Cycles** column is not supported in the C-SPY driver you are using, this menu command is not available.

Interrupt Log Summary window

The **Interrupt Log Summary** window is available from the C-SPY driver menu.

Interrupt	Count	First Time	Total (Time)	Total (%)	Fastest	Slowest	Min Interval	Max Interval
ADC	5	25.560us	95.400us	17.61	16.320us	30.120us	192.640us	1284.100us
RTC	4	41.700us	55.200us	22.66	13.800us	13.800us	27.060us	2687.420us

Approximative time count: 1
 Overflow count: 1
 Current time: 3350.080us us

This window displays a summary of logs of entrances to and exits from interrupts.

For more information, see *Getting started using interrupt logging*, page 274.

For information about how to get a graphical view of the interrupt events during the execution of your application, see *Timeline window—Interrupt Log graph*, page 287.

Requirements

The C-SPY simulator.

Display area

Each row in this area displays statistics about the specific interrupt based on the log information in these columns; and summary information is listed at the bottom of the display area:

Interrupt

The type of interrupt that occurred.

Count

The number of times the interrupt occurred.

First time

The first time the interrupt was executed.

Total (Time)**

The accumulated time spent in the interrupt.

Total (%)

The time in percent of the current time.

Fastest**

The fastest execution of a single interrupt of this type.

Slowest**

The slowest execution of a single interrupt of this type.

Min interval

The shortest time between two interrupts of this type.

The interval is specified as the time interval between the entry time for two consecutive interrupts.

Max interval

The longest time between two interrupts of this type.

The interval is specified as the time interval between the entry time for two consecutive interrupts.

Approximative time count

The information displayed depends on the C-SPY driver you are using.

For some C-SPY drivers, this information is not displayed or the value is always zero. In this case, all logs have an exact time stamp.

For other C-SPY drivers, a non-zero value is displayed. The value represents the amount of logs with an approximative time stamp. This might happen if the bandwidth in the communication channel is too low compared to the amount of data packets generated by the CPU or if the CPU generated packets with an approximative time stamp.

Overflow count

The information displayed depends on the C-SPY driver you are using.

For some C-SPY drivers, this information is not displayed or the value is always zero.

For other C-SPY drivers, the number represents the amount of overflows in the communication channel which can cause logs to be lost. If this happens, it indicates that logs might be incomplete. To solve this, make sure not to use all C-SPY log features simultaneously or check used bandwidth for the communication channel.

Current time**/Current cycles**

The information displayed depends on the C-SPY driver you are using.

For some C-SPY drivers, the value is always zero or not visible at all.

For other C-SPY drivers, the number represents the current time or cycles—the number of cycles or the execution time since the start of execution.

** Calculated in the same way as for the Execution time/cycles in the **Interrupt Log** window.

Context menu

This context menu is available:

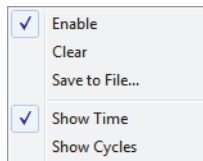

These commands are available:

Enable

Enables the logging system. The system will log information also when the window is closed.

Clear

Deletes the log information. Note that this will also happen when you reset the debugger.

Save to File

Displays a standard file selection dialog box where you can select the destination file for the log information. The entries in the log file are separated by `TAB` and `LF` characters. An **X** in the **Approx** column indicates that the timestamp is an approximation.

Show Time

Displays the **Time** column.

If the **Time** column is displayed by default in the C-SPY driver you are using, this menu command is not available.

Show Cycles

Displays the **Cycles** column.

If the **Cycles** column is not supported in the C-SPY driver you are using, this menu command is not available.

Timeline window—Interrupt Log graph

The Interrupt Log graph displays interrupts collected by the trace system. In other words, the graph provides a graphical view of the interrupt events during the execution of your application.

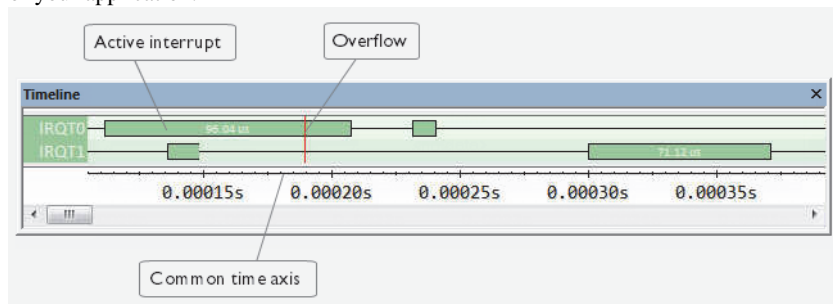

Note: There is a limit on the number of saved logs. When this limit is exceeded, the oldest entries in the buffer are erased.

Requirements

The C-SPY simulator.

Display area

- The label area at the left end of the graph displays the names of the interrupts.
- The graph itself shows active interrupts as a thick green horizontal bar where the white figure indicates the time spent in the interrupt. This graph is a graphical representation of the information in the **Interrupt Log** window, see *Interrupt Log window*, page 281.
- If the bar is displayed without horizontal borders, there are two possible causes:
 - The interrupt is reentrant and has interrupted itself. Only the innermost interrupt will have borders.
 - There are irregularities in the interrupt enter-leave sequence, probably due to missing logs.
- If the bar is displayed without a vertical border, the missing border indicates an approximate time for the log.
- A red vertical line indicates overflow, which means that the communication channel failed to transmit all interrupt logs from the target system.

At the bottom of the window, there is a common time axis that uses seconds as the time unit.

Context menu

This context menu is available:

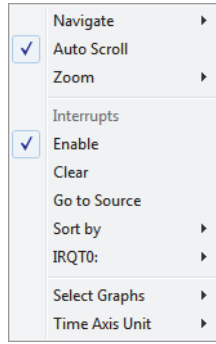

Note: The exact contents of the context menu you see on the screen depends on which features that your combination of software and hardware supports. However, the list of menu commands below is complete and covers all possible commands.

These commands are available:

Navigate

Commands for navigating the graph(s). Choose between:

Next moves the selection to the next relevant point in the graph. Shortcut key: right arrow.

Previous moves the selection backward to the previous relevant point in the graph. Shortcut key: left arrow.

First moves the selection to the first data entry in the graph. Shortcut key: Home.

Last moves the selection to the last data entry in the graph. Shortcut key: End.

End moves the selection to the last data in any displayed graph, in other words the end of the time axis. Shortcut key: Ctrl+End.

Auto Scroll

Toggles automatic scrolling on or off. When on, the most recently collected data is automatically displayed when you choose **Navigate>End**.

Zoom

Commands for zooming the window, in other words, changing the time scale. Choose between:

Zoom to Selection makes the current selection fit the window. Shortcut key: Return.

Zoom In zooms in on the time scale. Shortcut key: +

Zoom Out zooms out on the time scale. Shortcut key: –

10ns, 100ns, 1us, etc makes an interval of 10 nanoseconds, 100 nanoseconds, 1 microsecond, respectively, fit the window.

1ms, 10ms, etc makes an interval of 1 millisecond or 10 milliseconds, respectively, fit the window.

10m, 1h, etc makes an interval of 10 minutes or 1 hour, respectively, fit the window.

Interrupt

A heading that shows that the Interrupt Log-specific commands below are available.

Enable

Toggles the display of the graph on or off. If you disable a graph, that graph will be indicated as **OFF** in the window. If no data has been collected for a graph, **no data** will appear instead of the graph.

Clear

Deletes the log information. Note that this will also happen when you reset the debugger.

Go To Source

Displays the corresponding source code in an editor window, if applicable.

Sort by

Sorts the entries according to their ID or name. The selected order is used in the graph when new interrupts appear.

source

Goes to the previous/next log for the selected source.

Select Graphs

Selects which graphs to be displayed in the **Timeline** window.

Time Axis Unit

Selects the unit used in the time axis; choose between **Seconds** and **Cycles**.

If **Cycles** is not available, the graphs are based on different clock sources. In that case you can view cycle values as tooltip information by pointing at the graph with your mouse pointer.

The advanced cycle counter

- Introduction to the advanced cycle counter
- Using the cycle counter applications
- Reference information on the advanced cycle counter

Introduction to the advanced cycle counter

This section introduces the advanced cycle counter.

These topics are covered:

- Reasons for using the advanced cycle counter
- Briefly about the advanced cycle counter
- Requirements for using the advanced cycle counter

For related information, see *Registers window*, page 163.

REASONS FOR USING THE ADVANCED CYCLE COUNTER

The advanced cycle counter for MSP430 devices can help you, for example, to measure the DMA load, to profile a part of your application, or to measure how long some tasks take.

BRIEFLY ABOUT THE ADVANCED CYCLE COUNTER

The advanced cycle counter provides one or two 40-bit counters to count the number of cycles used by the CPU to execute certain tasks. On some devices, the cycle counter operation can be controlled using triggers. This allows, for example, conditional profiling, such as profiling a specific section of code.

The **Advanced Cycle Counter Control** window contains preconfigured *applications*, as well as the opportunity to customize your own use of the cycle counter.

REQUIREMENTS FOR USING THE ADVANCED CYCLE COUNTER

The advanced cycle counter is only available if you are using the C-SPY FET Debugger driver and an MSP430 device that supports the Enhanced Emulation Module at the

required level. Some devices have one cycle counter and some have two. If your device has one cycle counter, it is referred to as Cycle counter 0. If your device has two cycle counters, they are referred to as Cycle counter 0 and Cycle counter 1.

Using the cycle counter applications

This section gives you descriptions of the Cycle counter 1 applications available in the **Advanced Cycle Counter Control** window; that is, step-by-step descriptions of how to use the extra cycle counter.

These topics are covered:

- Counting all CPU cycles
- Measuring the DMA load versus the CPU load
- Profiling a specific part of your application
- Measuring the Trigger hits
- Measuring the number of CPU cycles for a task

COUNTING ALL CPU CYCLES

The **Cycle counter** application in the **Advanced Cycle Counter Control** window makes Cycle counter 1 behave like an ordinary cycle counter, counting all CPU cycles.

To count all CPU cycles:

- 1** Choose **Emulator>Advanced Cycle Counter** to open the **Advanced Cycle Counter Control** window.
- 2** Select the **Cycle counter** option.
- 3** Click the **Reset Counter 1** button to reset Cycle counter 1.
- 4** Execute your program and then stop the execution.

Cycle counter 1 in the **Cycle Counter Values** area now shows the number of CPU cycles that were executed.

MEASURING THE DMA LOAD VERSUS THE CPU LOAD

The **DMA load vs. CPU load** application in the **Advanced Cycle Counter Control** window measures the DMA load versus the CPU load by comparing the number of DMA bus cycles with the total number of bus cycles.

To measure the DMA load versus the CPU load:

- 1** Choose **Emulator>Advanced Cycle Counter** to open the **Advanced Cycle Counter Control** window.

- 2 Select the **DMA load vs. CPU load** option.
- 3 Click the **Reset Counter 1** button to reset Cycle counter 1.
- 4 Execute your program and then stop the execution.

In the **Cycle Counter Values** area, Cycle counter 1 now shows the number of DMA bus cycles, which can be compared with the number of CPU cycles shown by Cycle counter 0.

PROFILING A SPECIFIC PART OF YOUR APPLICATION

The **Profiling** application in the **Advanced Cycle Counter Control** window lets you profile a specific part of your program. Two reaction triggers or breakpoints define the start and stop points for the cycle counter. Cycle counter 1 starts to count cycles at the first trigger point and stops counting cycles at the second trigger.

Note: You cannot define which trigger point should be used as the start point or stop point; the first of the two that is reached will start the cycle counter. The execution does not stop at any of the triggers. You can compare the amount of time spent in a specific function with the result for cycle counter 0, which counts all cycles for the entire application.

To profile a section of your application:

- 1 Set up an advanced trigger at the start point of the code section that you want to measure. For information about setting advanced trigger breakpoints, see *Advanced trigger breakpoints*, page 109.
- 2 Set up a second advanced trigger at the stop point of the code section that you want to measure.
- 3 Choose **Emulator>Advanced Cycle Counter** to open the **Advanced Cycle Counter Control** window.
- 4 Select the **Profiling** option.
- 5 Select the start trigger point from the drop-down list **Reaction trigger 1**.
- 6 Select the stop trigger point from the drop-down list **Reaction trigger 2**.
- 7 Click the **Reset Counter 1** button to reset Cycle counter 1.
- 8 Execute your program and then stop the execution.

In the **Cycle Counter Values** area, Cycle counter 1 shows the number of CPU cycles spent in the selected code section or function. Cycle counter 0 shows all counted CPU cycles.

MEASURING THE TRIGGER HITS

The **Trigger hits** application in the **Advanced Cycle Counter Control** window measures the number of times a certain point in your program has been reached. Cycle counter 1 counts the number of times a trigger point has been triggered.

To measure how many times a point in your application is reached:

- 1** Set up an advanced trigger at the trigger point that you want to measure. For information about setting advanced trigger breakpoints, see *Advanced Trigger breakpoints dialog box*, page 134.
- 2** Choose **Emulator>Advanced Cycle Counter** to open the **Advanced Cycle Counter Control** window.
- 3** Select the **Trigger hits** option.
- 4** Select the trigger point from the drop-down list **Reaction trigger 1**.
- 5** Click the **Reset Counter 1** button to reset Cycle counter 1.
- 6** Execute your program and then stop the execution.

In the **Cycle Counter Values** area, Cycle counter 1 now shows the number of times the trigger point has been triggered.

MEASURING THE NUMBER OF CPU CYCLES FOR A TASK

The **Trip counter** application in the **Advanced Cycle Counter Control** window measures the number of CPU cycles required to execute a certain task or function. Cycle counter 1 starts to count cycles at the start trigger and stops counting cycles at the stop trigger. The execution stops when the stop trigger is reached.

To measure the number of cycles required to execute a task or function:

- 1** Set up an advanced trigger at the start point of the code section that you want to measure. For information about setting advanced trigger breakpoints, see *Advanced Trigger breakpoints dialog box*, page 134.
- 2** Set up a second advanced trigger at the stop point of the code section that you want to measure.
- 3** Choose **Emulator>Advanced Cycle Counter** to open the **Advanced Cycle Counter Control** window.
- 4** Select the **Trip counter** option.
- 5** Select the start trigger point from the drop-down list **Reaction trigger 1**.
- 6** Select the stop trigger point from the drop-down list **Reaction trigger 2**.
- 7** Click the **Reset Counter 1** button to reset Cycle counter 1.

- 8 Execute your program. The execution stops when the stop trigger is reached.

In the **Cycle Counter Values** area, Cycle counter 1 now shows the number of CPU cycles required to execute the task or function.

Reference information on the advanced cycle counter

This section gives reference information about the **Advanced Cycle Counter Control** window.

Advanced Cycle Counter Control window

The **Advanced Cycle Counter Control** window is available from the **Emulator** menu when the debugger is running.

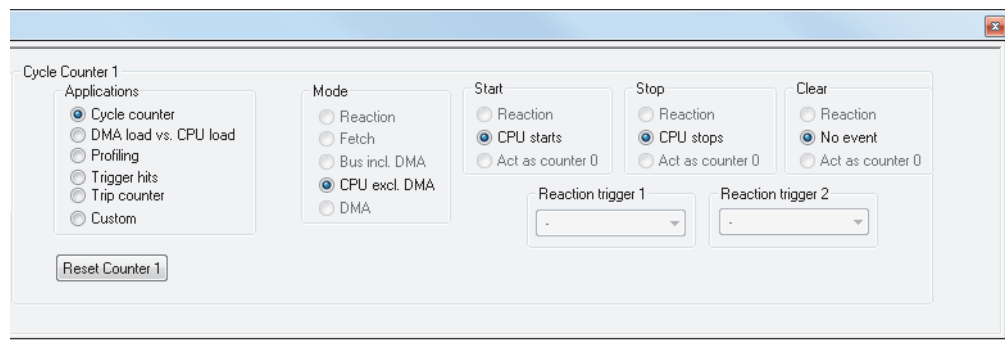

Use this window to set the behavior of Cycle counter 0 and Cycle counter 1, the extra cycle counter for some MSP430 devices.

Requirements

The C-SPY FET Debugger driver.

Applications

The **Advanced Cycle Counter Control** window contains preconfigured *applications* for Cycle counter 1, as well as the opportunity to customize your own use of the cycle counter. Use the cycle counter **Applications** to configure for what purpose to use the cycle counter. Choose between:

Cycle counter

Makes Cycle counter 1 count all CPU cycles, see *Counting all CPU cycles*, page 292.

DMA load vs. CPU load

Compares the number of DMA bus cycles with the total number of bus cycles, see *Measuring the DMA load versus the CPU load*, page 292.

Profiling

Profiles a specific part of your program, see *Profiling a specific part of your application*, page 293.

Trigger hits

Measures the number of times a certain point in your program has been reached, see *Measuring the Trigger hits*, page 294.

Trip counter

Measures the number of CPU cycles required to execute a certain task or function, see *Measuring the number of CPU cycles for a task*, page 294.

Custom

Make a custom application using the options in the **Cycle Counter 1** area.

Cycle counter values

Cycle counter 0

The value of cycle counter 0. Cycle counter 0 is the same cycle counter as the one displayed in the **Registers** window.

Cycle counter 1

The value of Cycle counter 1. Cycle counter 1 is controlled by the settings in the **Advanced Cycle Counter Control** window.

Mode

Reaction

Increments the counter on reactions. This option is only available for Cycle counter 1.

Fetch

Increments the counter on all instruction fetch cycles.

Bus incl. DMA

Increments the counter on all bus cycles (including DMA cycles).

CPU excl. DMA

Increments the counter on all CPU bus cycles (excluding DMA cycles).

DMA

Increments the counter on all DMA bus cycles.

Start**Reaction**

Uses the cycle counter reaction to start the cycle counter. This option is only available for Cycle counter 1.

CPU starts

Starts counting cycles when the CPU starts to execute.

Act as counter 0/1

Starts counting when the other counter starts. This option is only available for devices with two cycle counters.

Stop**Reaction**

Uses the cycle counter reaction to stop the cycle counter. This option is only available for Cycle counter 1.

CPU stops

Stops counting when the CPU stops the execution.

Act as counter 0/1

Stops counting when the other counter stops. This option is only available for devices with two cycle counters.

Clear**Reaction**

Clears the cycle counter on the cycle count reaction. This option is only available for Cycle counter 1.

No event

Does not clear the counter.

Act as counter 0/1

Clears the cycle counter when the other automatically resets.

Combinations of start, stop, and clear reactions

Start	Stop	Clear	Description
Reaction		Reaction	The cycle counter reaction starts the cycle counter and clears it at start.

Table 13: Cycle Counter 1, combinations of start, stop, and clear reactions

Start	Stop	Clear	Description
	Reaction	Reaction	The cycle counter reaction stops and clears the cycle counter.
Reaction	Reaction		If the cycle counter is stopped, the cycle counter reaction starts the counter. If the counter is running, the cycle counter reaction stops the counter.
Reaction	Reaction	Reaction	If the cycle counter is stopped, the cycle counter reaction starts the counter and clears it at start. If the counter is running, the cycle counter reaction stops the counter.

Table 13: Cycle Counter 1, combinations of start, stop, and clear reactions (Continued)

Reaction trigger 1, Reaction trigger 2

Selects breakpoints to act as a reaction triggers.

Reset Counter 0/1

Resets the value and state of the cycle counter.

State storage

- Introduction to state storage
- Using state storage
- Reference information on state storage

Introduction to state storage

This section introduces the state storage module, a limited variant of a traditional trace module available for the C-SPY FET Debugger driver.

These topics are covered:

- Reasons for using state storage
- Briefly about state storage
- Requirements

For related information, see also:

- *The sequencer*, page 305

REASONS FOR USING STATE STORAGE

State storage allows you to examine the last eight states or instructions that were executed before a specific point was reached or a specific event occurred, or the next eight states that will be executed after a specific point is reached or a specific event occurs.

BRIEFLY ABOUT STATE STORAGE

The state storage module is a limited variant of a traditional trace module. It can store eight states and can be used for monitoring program states or program flow, without interfering with the execution. It uses a built-in buffer to store MAB, MDB, and CPU control signal information.

REQUIREMENTS

The state storage module is only available if you are using the C-SPY FET Debugger driver and a device that supports the Enhanced Emulation Module at the required level.

Using state storage

This section gives you step-by-step descriptions about how to set up state storage.

SETTING UP STATE STORAGE

To use the state storage module, you must:

- 1 Define one or several range breakpoints or conditional breakpoints.
- 2 In the breakpoints dialog box, select the action **State Storage Trigger** for these breakpoints. This means that the breakpoint is defined as a state storage trigger. (State storage can also be triggered from the **Sequencer Control** window.)

Note: Depending on the behavior you want when the state storage module is triggered, it is useful to consider the combination of the **Action** options and the options available in the **State Storage Control** window. See the examples following immediately after these steps.

- 3 Choose **Emulator>State Storage Control** to open the **State Storage Control** window.
- 4 Select the option **Enable state storage**. Set the options **Buffer wrap around**, **Trigger action**, and **Storage action** according to your preferences.

In the list **State Storage Triggers**, all breakpoints defined as state storage triggers are listed.

For more details about the options, see *State Storage Control window*, page 301.

- 5 Click **Apply**.
- 6 Choose **Emulator>State Storage window** to open the **State Storage** window.
- 7 Choose **Debug>Go** to execute your application. Before you can view the state storage information, you must stop the execution. You can do this, for instance, by using the **Break** command.

For information about the window contents, see *State Storage window*, page 303.

Example

As an example, assume the following setup:

- There is a conditional breakpoint which has both of the action options selected—**Break** and **State Storage Trigger**
- The state storage options **Instruction fetch** and **Buffer wrap around** are selected in the **State Storage Control** window.

This will start the state storage immediately when you start executing your application. When the breakpoint is triggered, the execution will stop and the last eight states can be inspected in the **State Storage** window.

However, if you do not want the state storage module to start until a specific state is reached, you would usually not want the execution to stop, because no state information has been stored yet.

In this case, select the **State Storage Trigger** action in the **Conditional breakpoints** dialog box (making sure that **Break** is deselected), and deselect the option **Buffer wrap around** in the **State Storage Control** window.

When the breakpoint is triggered, the execution will not stop, but the state storage will start. Because the option **Buffer wrap around** is deselected, you have ensured that the data in the buffer will not be overwritten.

When another breakpoint (which has **Break** selected) is triggered, or if you stop the execution by clicking the **Break** button, the **State Storage** window will show eight states starting with the breakpoint that was used for starting the state storage module.

Reference information on state storage

This section gives reference information about these windows:

- *State Storage Control window*, page 301
- *State Storage window*, page 303

State Storage Control window

The **State Storage Control** window is available from the **Emulator** menu.

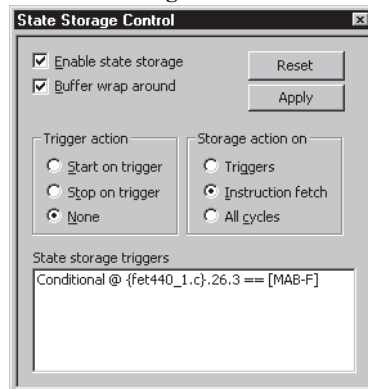

Use this window to define how to use the state storage module. The window is only available for devices that support the Enhanced Emulation Module at the required level.

Requirements

The C-SPY FET Debugger driver.

Enable state storage

Enables the state storage module.

Buffer wrap around

Determines whether the state storage buffer should wrap around. If you select this option, the state storage buffer is continuously overwritten until the execution is stopped or a breakpoint is triggered. Only the eight last states are stored.

Alternatively, in order not to overwrite the information in the state storage buffer, deselect this option. To guarantee that the eight first states will be stored, you should also click **Reset**.

Reset

Resets the state storage module.

Trigger action

Selects which action to take when breakpoints defined as state storage triggers are triggered:

Start on trigger

Starts state storage when the breakpoint is triggered.

Stop on trigger

Starts state storage immediately when execution starts. State storage stops when the breakpoint is triggered.

None

Starts state storage immediately when execution starts. State storage does not stop when the breakpoint is triggered. However, if execution stops, state storage also stops but it will resume when execution resumes.

Storage action on

Selects when the state information should be collected:

Triggers

Stores state information at the time when the state storage trigger is triggered. That is, when the breakpoint defined as a state storage trigger is triggered.

Instruction fetch

Stores state information at all instruction fetches.

All cycles

Stores state information for all cycles.

State storage triggers

Lists all the breakpoints that are defined as state storage triggers. That is, the breakpoints that have the action **State Storage Trigger** selected.

State Storage window

The **State Storage** window is available from the **Emulator** menu.

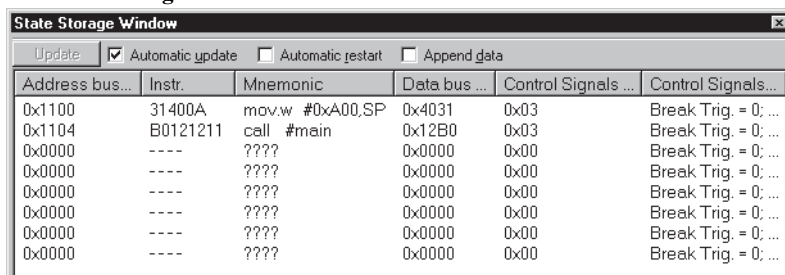

Address bus...	Instr.	Mnemonic	Data bus ...	Control Signals ...	Control Signals...
0x1100	31400A	mov.w #0xA00,SP	0x4031	0x03	Break Trig. = 0; ...
0x1104	B0121211	call #main	0x12B0	0x03	Break Trig. = 0; ...
0x0000	----	????	0x0000	0x00	Break Trig. = 0; ...
0x0000	----	????	0x0000	0x00	Break Trig. = 0; ...
0x0000	----	????	0x0000	0x00	Break Trig. = 0; ...
0x0000	----	????	0x0000	0x00	Break Trig. = 0; ...
0x0000	----	????	0x0000	0x00	Break Trig. = 0; ...
0x0000	----	????	0x0000	0x00	Break Trig. = 0; ...

This window displays state storage information for eight states. Invalid data is displayed in red color.

Requirements

The C-SPY FET Debugger driver.

Toolbar

The toolbar contains:

Update

Refreshes the data in the **State Storage** window, alternatively appends new data.

Automatic update

Updates the data in the **State Storage** window automatically each time new data is available in the state storage buffer.

Automatic restart

Resets the state storage module for consecutive data readouts after each readout.

Append data

Appends collected data from the state storage buffer to the data that is already present in the **State Storage** window. The new data is added below the data that is already present.

Display area

This area contains these columns:

Address bus

The stored value of the address bus.

Instruction

The instruction.

Mnemonic

The mnemonic.

Data bus

The stored content of the data bus.

The sequencer

- Introduction to the sequencer
- Using the sequencer
- Reference information on the sequencer

Introduction to the sequencer

This section introduces the sequencer module.

These topics are covered:

- Reasons for using the sequencer
- Briefly about the sequencer
- Requirements for using the sequencer

For related information, see also:

- *State storage*, page 299

REASONS FOR USING THE SEQUENCER

The sequencer is useful if you, for instance, want to stop the execution or start the state storage module under certain conditions, for instance a specific program flow. If you combine this with letting the state storage module continuously store information, you will have useful state information logged in the **State Storage** window when the execution stops.

BRIEFLY ABOUT THE SEQUENCER

The sequencer module is a simple state machine that lets you break the execution or trigger the state storage module using a more complex method than a standard breakpoint.

In a simple setup, you can define three transition triggers, where the last one triggers an action. In an advanced setup, the state machine can have four states (0-3). State 0 is the starting state, and state 3 is the state that triggers a breakpoint (the action state). This breakpoint can be designed either to stop execution, or to trigger the state storage module.

REQUIREMENTS FOR USING THE SEQUENCER

The sequencer module is only available for the C-SPY FET Debugger driver and if you are using a device that supports the Enhanced Emulation Module at the required level.

Using the sequencer

This section gives you step-by-step descriptions about how to use certain features of the sequencer module.

These topics are covered:

- Setting up the sequencer (simple setup)
- Setting up the sequencer (advanced setup)
- Using the sequencer to locate a problem

SETTING UP THE SEQUENCER (SIMPLE SETUP)

In a simple setup, you can define three transition triggers, where the last one triggers an action.

To define a simple sequencer setup:

- 1** Choose **Emulator>Sequencer Control** to open the **Sequencer Control** window.
- 2** Select the option **Enable Sequencer**.
- 3** Use the **Transition trigger** drop-down lists to define three breakpoints, where the last breakpoint should act as a transition trigger.

SETTING UP THE SEQUENCER (ADVANCED SETUP)

In an advanced setup, the state machine can have four states (0-3). State 0 is the starting state, and state 3 is the state that triggers a breakpoint (the action state). This breakpoint can be designed either to stop execution, or to trigger the state storage module.

To define an advanced sequencer setup:

- 1** Choose **Emulator>Sequencer Control** to open the **Sequencer Control** window.
- 2** Select the option **Enable Sequencer**.
- 3** Click the **Advanced** button. This will let you define 4 states (0-3) with two transition triggers each (a and b).

From the eight available hardware breakpoints (0-7) of the device, breakpoint number 7 will be reserved for state 3. The **Transition trigger** drop-down lists let you define one breakpoint each, where the breakpoint should act as a transition trigger.

- 4 For each transition trigger, define which state should be the next state after the transition.

Use the following options:

State Storage Trigger Select a breakpoint from the drop-down list to move the state machine from one state to another. **Note:** To do this you must first define the required conditional breakpoints.

Next state Select a state to define which state should be the next state after the transition.

- 5 Select an action to determine the result of the final transition trigger. If you select the option **Break**, the execution will stop. If you select the option **State Storage Trigger**, the state storage module will be triggered.

USING THE SEQUENCER TO LOCATE A PROBLEM

Consider this example:

```
void my_putchar(char c)
{
    ...
    /* Code suspected to be erroneous */
    ...
}

void my_function(void)
{
    ...
    my_putchar('a');
    ...
    my_putchar('x');
    ...
    my_putchar('@');
    ...
}
```

In this example, the customized `putchar` function `my_putchar` has for some reason a problem with special characters. To locate the problem, it might be useful to stop execution when the function is called, but only when it is called with one of the problematic characters as the argument.

To locate the problem:

- 1 Set a hardware breakpoint on the statement `my_putchar('@');`.
- 2 Set another breakpoint on the suspected code within the function `my_putchar()`.

3 Define these breakpoints as transition triggers. Choose **Emulator>Sequencer Control** to open the **Sequencer Control** window. Select the option **Enable sequencer**.

4 In this simple example you only need two transition triggers.

Make sure the following options are selected:

Option	Setting
Transition trigger 0	The breakpoint which is set on the function call <code>my_putchar('a');</code>
Transition trigger 1	The breakpoint which is set on the suspected code within the function <code>my_putchar()</code>
Action	Break

Table 14: Sequencer settings - example

The transition trigger 1 depends on the transition trigger 0. This means that the execution will stop only when the function `my_putchar()` is called by the function call `my_putchar('a');`

Click **OK**.

5 Set up the state storage module. Choose **Emulator>State Storage Control** to open the **State Storage Control** window.

Make sure the following options are selected:

Option	Setting
Enable state storage	Selected
Buffer wrap around	Selected
Storage action	Instruction fetch
Trigger action	None

Table 15: State Storage Control settings—example

Click **OK**.

6 Start the program execution. The state storage module will continuously store trace information. Execution stops when the function `my_putchar()` has been called by the function call `my_putchar('a');`

7 Choose **Emulator>State Storage Window** to open the **State Storage** window. You can now examine the stored trace information. For more information, see *State Storage window*, page 303.

- 8 When the sequencer is in state 3, the C-SPY breakpoint mechanism—which is used for all breakpoints, not only transition triggers—can be locked. Therefore, you should always end the session with one of these steps:
- Disabling the sequencer module. This will restore all breakpoint actions.
 - Resetting the state machine by clicking the **Reset States** button. The sequencer will still be active and trigger on the defined setup during the program execution.

Reference information on the sequencer

This section gives reference information about the **Sequencer Control** window.

Sequencer Control window

The **Sequencer Control** window is available from the **Emulator** menu.

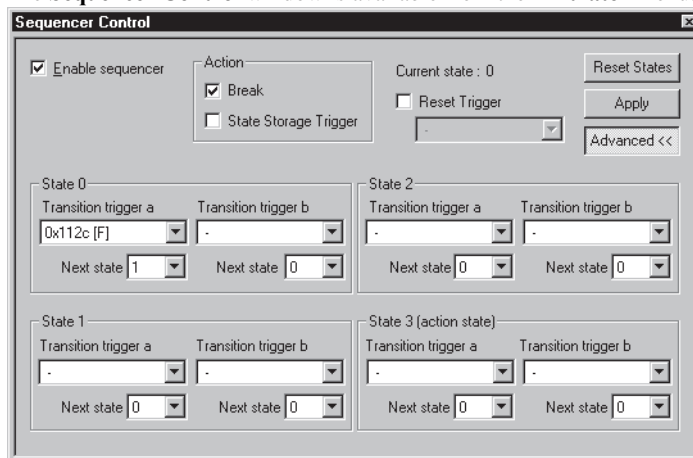

Use this window to break the execution or trigger the state storage module, using a more complex method than a standard breakpoint. The window is only available for devices that support the Enhanced Emulation Module at the required level.

For related information about state storage, see *State storage*, page 299.

Requirements

The C-SPY FET Debugger driver.

Enable Sequencer

Enables the sequencer.

Action

Controls the result of the final transition trigger:

Break

Stops the execution.

State Storage Trigger

Triggers to move the state machine from one state to another and activates the state storage module. Requires that you select a conditional breakpoint, that you have defined, from the **Transition trigger** drop-down list.

Current state

Displays the current state of the state machine.

Reset Trigger

Selects a trigger that will reset the state machine.

Reset States

Sets the state machine to state 0.

Advanced

Displays the advanced setup options. This will let you define four states (numbered 0-3) with two transition triggers each (a and b). For each transition trigger, you can define which state should be the next state after the transition.

State 0–3

Controls the transition triggers and the state that follows the transitions.

Transition trigger a

Selects a breakpoint to act as a transition trigger.

Transition trigger b

Selects a breakpoint to act as a transition trigger.

Next state

Select the next state after the transition.

For state 3—the final transition trigger—you must also define an **Action: Break** or **State Storage Trigger**.

C-SPY macros

- Introduction to C-SPY macros
- Using C-SPY macros
- Reference information on the macro language
- Reference information on reserved setup macro function names
- Reference information on C-SPY system macros
- Graphical environment for macros

Introduction to C-SPY macros

These topics are covered:

- Reasons for using C-SPY macros
- Briefly about using C-SPY macros
- Briefly about setup macro functions and files
- Briefly about the macro language

REASONS FOR USING C-SPY MACROS

You can use C-SPY macros either by themselves or in conjunction with complex breakpoints and interrupt simulation to perform a wide variety of tasks. Some examples where macros can be useful:

- Automating the debug session, for instance with trace printouts, printing values of variables, and setting breakpoints.
- Hardware configuring, such as initializing hardware registers.
- Feeding your application with simulated data during runtime.
- Simulating peripheral devices, see the chapter *Interrupts*. This only applies if you are using the simulator driver.
- Developing small debug utility functions, for instance calculating the stack depth.

BRIEFLY ABOUT USING C-SPY MACROS

To use C-SPY macros, you should:

- Write your macro variables and functions and collect them in one or several *macro files*
- Register your macros
- Execute your macros

For registering and executing macros, there are several methods to choose between. Which method you choose depends on which level of interaction or automation you want, and depending on at which stage you want to register or execute your macro.

BRIEFLY ABOUT SETUP MACRO FUNCTIONS AND FILES

There are some reserved *setup macro function names* that you can use for defining macro functions which will be called at specific times, such as:

- Once after communication with the target system has been established but before downloading the application software
- Once after your application software has been downloaded
- Each time the reset command is issued
- Once when the debug session ends

To define a macro function to be called at a specific stage, you should define and register a macro function with one of the reserved names. For instance, if you want to clear a specific memory area before you load your application software, the macro setup function `execUserPreload` should be used. This function is also suitable if you want to initialize some CPU registers or memory-mapped peripheral units before you load your application software.

You should define these functions in a *setup macro file*, which you can load before C-SPY starts. Your macro functions will then be automatically registered each time you start C-SPY. This is convenient if you want to automate the initialization of C-SPY, or if you want to register multiple setup macros.

For more information about each setup macro function, see *Reference information on reserved setup macro function names*, page 323.

BRIEFLY ABOUT THE MACRO LANGUAGE

The syntax of the macro language is very similar to the C language. There are:

- *Macro statements*, which are similar to C statements.
- *Macro functions*, which you can define with or without parameters and return values.

- Predefined built-in *system macros*, similar to C library functions, which perform useful tasks such as opening and closing files, setting breakpoints, and defining simulated interrupts.
- *Macro variables*, which can be global or local, and can be used in C-SPY expressions.
- *Macro strings*, which you can manipulate using predefined system macros.

For more information about the macro language components, see *Reference information on the macro language*, page 318.

Example

Consider this example of a macro function which illustrates the various components of the macro language:

```
__var oldVal;
CheckLatest(val)
{
    if (oldVal != val)
    {
        __message "Message: Changed from ", oldVal, " to ", val, "\n";
        oldVal = val;
    }
}
```

Note: Reserved macro words begin with double underscores to prevent name conflicts.

Using C-SPY macros

These tasks are covered:

- Registering C-SPY macros—an overview
- Executing C-SPY macros—an overview
- Registering and executing using setup macros and setup files
- Executing macros using Quick Watch
- Executing a macro by connecting it to a breakpoint
- Aborting a C-SPY macro

For more examples using C-SPY macros, see:

- The tutorial about simulating an interrupt, which you can find in the Information Center
- *Initializing target hardware before C-SPY starts*, page 49

REGISTERING C-SPY MACROS—AN OVERVIEW

C-SPY must know that you intend to use your defined macro functions, and therefore you must *register* your macros. There are various ways to register macro functions:

- You can register macro functions during the C-SPY startup sequence, see *Registering and executing using setup macros and setup files*, page 315.
- You can register macros interactively in the **Macro Registration** window, see *Macro Registration window*, page 366. Registered macros appear in the **Debugger Macros** window, see *Debugger Macros window*, page 368.
- You can register a file containing macro function definitions, using the system macro `__registerMacroFile`. This means that you can dynamically select which macro files to register, depending on the runtime conditions. Using the system macro also lets you register multiple files at the same moment. For information about the system macro, see *__registerMacroFile*, page 345.

Which method you choose depends on which level of interaction or automation you want, and depending on at which stage you want to register your macro.

EXECUTING C-SPY MACROS—AN OVERVIEW

There are various ways to execute macro functions:

- You can execute macro functions during the C-SPY startup sequence and at other predefined stages during the debug session by defining setup macro functions in a setup macro file, see *Registering and executing using setup macros and setup files*, page 315.
- The **Quick Watch** window lets you evaluate expressions, and can thus be used for executing macro functions. For an example, see *Executing macros using Quick Watch*, page 315.
- The **Macro Quicklaunch** window is similar to the **Quick Watch** window, but is more specifically designed for C-SPY macros. See *Macro Quicklaunch window*, page 370.
- A macro can be connected to a breakpoint; when the breakpoint is triggered the macro is executed. For an example, see *Executing a macro by connecting it to a breakpoint*, page 316.

Which method you choose depends on which level of interaction or automation you want, and depending on at which stage you want to execute your macro.

REGISTERING AND EXECUTING USING SETUP MACROS AND SETUP FILES

It can be convenient to register a macro file during the C-SPY startup sequence. To do this, specify a macro file which you load before starting the debug session. Your macro functions will be automatically registered each time you start the debugger.

If you use the reserved setup macro function names to define the macro functions, you can define exactly at which stage you want the macro function to be executed.

To define a setup macro function and load it during C-SPY startup:

- 1 Create a new text file where you can define your macro function.

For example:

```
execUserSetup()
{
    ...
    __registerMacroFile("MyMacroUtils.mac");
    __registerMacroFile("MyDeviceSimulation.mac");
}
```

This macro function registers the additional macro files `MyMacroUtils.mac` and `MyDeviceSimulation.mac`. Because the macro function is defined with the function name `execUserSetup`, it will be executed directly after your application has been downloaded.

- 2 Save the file using the filename extension `mac`.
- 3 Before you start C-SPY, choose **Project>Options>Debugger>Setup**. Select the **Use macro file** option, and choose the macro file you just created.

The macros will now be registered during the C-SPY startup sequence.

EXECUTING MACROS USING QUICK WATCH

The **Quick Watch** window lets you dynamically choose when to execute a macro function.

- 1 Consider this simple macro function that checks the status of a timer enable bit:

```
TimerStatus()
{
    if ((TimerStatreg & 0x01) != 0) /* Checks the status of reg */
        return "Timer enabled"; /* C-SPY macro string used */
    else
        return "Timer disabled"; /* C-SPY macro string used */
}
```

- 2 Save the macro function using the filename extension `mac`.
- 3 To load the macro file, choose **View>Macros>Macro Registration**. The **Macro Registration** window is displayed. Click **Add** and locate the file using the file browser. The macro file appears in the list of macros in the **Macro Registration** window.
- 4 Select the macro you want to register and your macro will appear in the **Debugger Macros** window.
- 5 Choose **View>Quick Watch** to open the **Quick Watch** window, type the macro call `TimerStatus()` in the text field and press Return,

Alternatively, in the macro file editor window, select the macro function name `TimerStatus()`. Right-click, and choose **Quick Watch** from the context menu that appears.

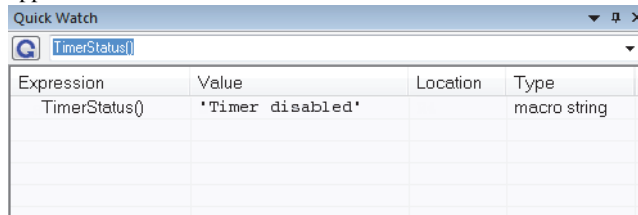

The macro will automatically be displayed in the **Quick Watch** window. For more information, see *Quick Watch window*, page 99.

EXECUTING A MACRO BY CONNECTING IT TO A BREAKPOINT

You can connect a macro to a breakpoint. The macro will then be executed when the breakpoint is triggered. The advantage is that you can stop the execution at locations of particular interest and perform specific actions there.



For instance, you can easily produce log reports containing information such as how the values of variables, symbols, or registers change. To do this you might set a breakpoint on a suspicious location and connect a log macro to the breakpoint. After the execution you can study how the values of the registers have changed.

To create a log macro and connect it to a breakpoint:

- 1 Assume this skeleton of a C function in your application source code:

```
int fact(int x)
{
    ...
}
```

- 2 Create a simple log macro function like this example:

```
logfact ()
{
  __message "fact (" ,x, " )";
}
```

The `__message` statement will log messages to the **Debug Log** window.

Save the macro function in a macro file, with the filename extension `mac`.

- 3 To register the macro, choose **View>Macros>Macro Registration** to open the **Macro Registration** window and add your macro file to the list. Select the file to register it. Your macro function will appear in the **Debugger Macros** window.
- 4 To set a code breakpoint, click the **Toggle Breakpoint** button on the first statement within the function `fact` in your application source code. Choose **View>Breakpoints** to open the **Breakpoints** window. Select your breakpoint in the list of breakpoints and choose the **Edit** command from the context menu.
- 5 To connect the log macro function to the breakpoint, type the name of the macro function, `logfact ()`, in the **Action** field and click **OK** to close the dialog box.
- 6 Execute your application source code. When the breakpoint is triggered, the macro function will be executed. You can see the result in the **Debug Log** window.

Note that the expression in the **Action** field is evaluated only when the breakpoint causes the execution to really stop. If you want to log a value and then automatically continue execution, you can either:

- Use a **Log** breakpoint, see *Log breakpoints dialog box*, page 123
 - Use the **Condition** field instead of the **Action** field. For an example, see *Performing a task and continuing execution*, page 118.
- 7 You can easily enhance the log macro function by, for instance, using the `__fmessage` statement instead, which will print the log information to a file. For information about the `__fmessage` statement, see *Formatted output*, page 321.

For an example where a serial port input buffer is simulated using the method of connecting a macro to a breakpoint, see the tutorial *Simulating an interrupt* in the Information Center.

ABORTING A C-SPY MACRO

To abort a C-SPY macro:

- 1 Press **Ctrl+Shift+.** (period) for a short while.
- 2 A message that says that the macro has terminated is displayed in the **Debug Log** window.

This method can be used if you suspect that something is wrong with the execution, for example because it seems not to terminate in a reasonable time.

Reference information on the macro language

Reference information about:

- *Macro functions*, page 318
- *Macro variables*, page 318
- *Macro parameters*, page 319
- *Macro strings*, page 319
- *Macro statements*, page 320
- *Formatted output*, page 321

MACRO FUNCTIONS

C-SPY macro functions consist of C-SPY variable definitions and macro statements which are executed when the macro is called. An unlimited number of parameters can be passed to a macro function, and macro functions can return a value on exit.

A C-SPY macro has this form:

```
macroName (parameterList)
{
    macroBody
}
```

where *parameterList* is a list of macro parameters separated by commas, and *macroBody* is any series of C-SPY variable definitions and C-SPY statements.

Type checking is neither performed on the values passed to the macro functions nor on the return value.

MACRO VARIABLES

A macro variable is a variable defined and allocated outside your application. It can then be used in a C-SPY expression, or you can assign application data—values of the variables in your application—to it. For more information about C-SPY expressions, see *C-SPY expressions*, page 82.

The syntax for defining one or more macro variables is:

```
__var nameList;
```

where *nameList* is a list of C-SPY variable names separated by commas.

A macro variable defined outside a macro body has global scope, and it exists throughout the whole debugging session. A macro variable defined within a macro body is created when its definition is executed and destroyed on return from the macro.

By default, macro variables are treated as signed integers and initialized to 0. When a C-SPY variable is assigned a value in an expression, it also acquires the type of that expression. For example:

Expression	What it means
<code>myvar = 3.5;</code>	<code>myvar</code> is now type <code>double</code> , value <code>3.5</code> .
<code>myvar = (int*)i;</code>	<code>myvar</code> is now type <code>pointer to int</code> , and the value is the same as <code>i</code> .

Table 16: Examples of C-SPY macro variables

In case of a name conflict between a C symbol and a C-SPY macro variable, C-SPY macro variables have a higher precedence than C variables. Note that macro variables are allocated on the debugger host and do not affect your application.

MACRO PARAMETERS

A macro parameter is intended for parameterization of device support. The named parameter will behave as a normal C-SPY macro variable with these differences:

- The parameter definition can have an initializer
- Values of a parameters can be set through options (either in the IDE or in `cspybat`).
- A value set from an option will take precedence over a value set by an initializer
- A parameter must have an initializer, be set through an option, or both. Otherwise, it has an undefined value, and accessing it will cause a runtime error.

The syntax for defining one or more macro parameters is:

```
__param param[=value, ...;]
```

Use the command line option `--macro_param` to specify a value to a parameter, see `--macro_param`, page 391.

MACRO STRINGS

In addition to C types, macro variables can hold values of *macro strings*. Note that macro strings differ from C language strings.

When you write a string literal, such as `"Hello!"`, in a C-SPY expression, the value is a macro string. It is not a C-style character pointer `char*`, because `char*` must point to a sequence of characters in target memory and C-SPY cannot expect any string literal to actually exist in target memory.

You can manipulate a macro string using a few built-in macro functions, for example `__strFind` or `__subString`. The result can be a new macro string. You can

concatenate macro strings using the + operator, for example `str + "tail"`. You can also access individual characters using subscription, for example `str[3]`. You can get the length of a string using `sizeof(str)`. Note that a macro string is not NULL-terminated.

The macro function `__toString` is used for converting from a NULL-terminated C string in your application (`char*` or `char[]`) to a macro string. For example, assume this definition of a C string in your application:

```
char const *cstr = "Hello";
```

Then examine these macro examples:

```
__var str;          /* A macro variable */
str = cstr          /* str is now just a pointer to char */
sizeof str         /* same as sizeof (char*), typically 2 or 4 */
str = __toString(cstr,512) /* str is now a macro string */
sizeof str        /* 5, the length of the string */
str[1]            /* 101, the ASCII code for 'e' */
str += " World!" /* str is now "Hello World!" */
```

See also *Formatted output*, page 321.

MACRO STATEMENTS

Statements are expected to behave in the same way as the corresponding C statements would do. The following C-SPY macro statements are accepted:

Expressions

```
expression;
```

For more information about C-SPY expressions, see *C-SPY expressions*, page 82.

Conditional statements

```
if (expression)
    statement
```

```
if (expression)
    statement
else
    statement
```

Loop statements

```
for (init_expression; cond_expression; update_expression)
    statement
```

```
while (expression)
    statement
```

```
do
    statement
while (expression);
```

Return statements

```
return;
```

```
return expression;
```

If the return value is not explicitly set, signed int 0 is returned by default.

Blocks

Statements can be grouped in blocks.

```
{
    statement1
    statement2
    .
    .
    statementN
}
```

FORMATTED OUTPUT

C-SPY provides various methods for producing formatted output:

<code>__message <i>argList</i>;</code>	Prints the output to the Debug Log window.
<code>__fmessage <i>file</i>, <i>argList</i>;</code>	Prints the output to the designated file.
<code>__smessage <i>argList</i>;</code>	Returns a string containing the formatted output.

where *argList* is a comma-separated list of C-SPY expressions or strings, and *file* is the result of the `__openFile` system macro, see `__openFile`, page 339.

To produce messages in the **Debug Log** window:

```
var1 = 42;
var2 = 37;
__message "This line prints the values ", var1, " and ", var2,
" in the Debug Log window.";
```

This produces this message in the **Debug Log** window:

This line prints the values 42 and 37 in the Debug Log window.

To write the output to a designated file:

```
__fmessage myfile, "Result is ", res, "!\n";
```

To produce strings:

```
myMacroVar = __smessage 42, " is the answer.";
myMacroVar now contains the string "42 is the answer.".
```

Specifying display format of arguments

To override the default display format of a scalar argument (number or pointer) in *argList*, suffix it with a `:` followed by a format specifier. Available specifiers are:

<code>%b</code>	for binary scalar arguments
<code>%o</code>	for octal scalar arguments
<code>%d</code>	for decimal scalar arguments
<code>%x</code>	for hexadecimal scalar arguments
<code>%c</code>	for character scalar arguments

These match the formats available in the **Watch** and **Locals** windows, but number prefixes and quotes around strings and characters are not printed. Another example:

```
__message "The character '", cvar:%c, "' has the decimal value
", cvar;
```

Depending on the value of the variables, this produces this message:

The character 'A' has the decimal value 65

Note: A character enclosed in single quotes (a character literal) is an integer constant and is not automatically formatted as a character. For example:

```
__message 'A', " is the numeric value of the character ",
'A':%c;
```

would produce:

```
65 is the numeric value of the character A
```

Note: The default format for certain types is primarily designed to be useful in the **Watch** window and other related windows. For example, a value of type `char` is formatted as 'A' (0x41), while a pointer to a character (potentially a C string) is formatted as 0x8102 "Hello", where the string part shows the beginning of the string (currently up to 60 characters).

When printing a value of type `char*`, use the `%x` format specifier to print just the pointer value in hexadecimal notation, or use the system macro `__toString` to get the full string value.

Reference information on reserved setup macro function names

There are reserved setup macro function names that you can use for defining your setup macro functions. By using these reserved names, your function will be executed at defined stages during execution. For more information, see *Briefly about setup macro functions and files*, page 312.

Reference information about:

- `execUserPreload`
- `execUserExecutionStarted`
- `execUserExecutionStopped`
- `execUserSetup`
- `execUserPreReset`
- `execUserReset`
- `execUserExit`

execUserPreload

Syntax	<code>execUserPreload</code>
For use with	All C-SPY drivers.
Description	Called after communication with the target system is established but before downloading the target application. Implement this macro to initialize memory locations and/or registers which are vital for loading data properly.

execUserExecutionStarted

Syntax	<code>execUserExecutionStarted</code>
For use with	All C-SPY drivers.
Description	Called when the debugger is about to start or resume execution. The macro is not called when performing a one-instruction assembler step, in other words, Step or Step Into in the Disassembly window.

execUserExecutionStopped

Syntax	<code>execUserExecutionStopped</code>
For use with	All C-SPY drivers.
Description	Called when the debugger has stopped execution. The macro is not called when performing a one-instruction assembler step, in other words, Step or Step Into in the Disassembly window.

execUserSetup

Syntax	<code>execUserSetup</code>
For use with	All C-SPY drivers.
Description	Called once after the target application is downloaded. Implement this macro to set up the memory map, breakpoints, interrupts, register macro files, etc.



If you define interrupts or breakpoints in a macro file that is executed at system start (using `execUserSetup`) we strongly recommend that you also make sure that they are removed at system shutdown (using `execUserExit`). An example is available in `SetupSimple.mac`, see the tutorials in the Information Center.

The reason for this is that the simulator saves interrupt settings between sessions and if they are not removed they will get duplicated every time `execUserSetup` is executed again. This seriously affects the execution speed.

execUserPreReset

Syntax	<code>execUserPreReset</code>
For use with	All C-SPY drivers.
Description	Called each time just before the reset command is issued. Implement this macro to set up any required device state.

execUserReset

Syntax	<code>execUserReset</code>
For use with	All C-SPY drivers.
Description	Called each time just after the reset command is issued. Implement this macro to set up and restore data.

execUserExit

Syntax	<code>execUserExit</code>
For use with	All C-SPY drivers.
Description	Called once when the debug session ends. Implement this macro to save status data etc.

Reference information on C-SPY system macros

This section gives reference information about each of the C-SPY system macros.

This table summarizes the pre-defined system macros:

Macro	Description
<code>__abortLaunch</code>	Aborts the launch of the debugger
<code>__cancelAllInterrupts</code>	Cancels all ordered interrupts
<code>__cancelInterrupt</code>	Cancels an interrupt
<code>__clearBreak</code>	Clears a breakpoint

Table 17: Summary of system macros

Macro	Description
<code>__closeFile</code>	Closes a file that was opened by <code>__openFile</code>
<code>__delay</code>	Delays execution
<code>__disableInterrupts</code>	Disables generation of interrupts
<code>__driverType</code>	Verifies the driver type
<code>__enableInterrupts</code>	Enables generation of interrupts
<code>__evaluate</code>	Interprets the input string as an expression and evaluates it
<code>__fillMemory8</code>	Fills a specified memory area with a byte value
<code>__fillMemory16</code>	Fills a specified memory area with a 2-byte value
<code>__fillMemory32</code>	Fills a specified memory area with a 4-byte value
<code>__getSelectedCore</code>	Only for use with IAR Embedded Workbench products that support multicore debugging
<code>__isBatchMode</code>	Checks if C-SPY is running in batch mode or not.
<code>__loadImage</code>	Loads a debug image
<code>__memoryRestore</code>	Restores the contents of a file to a specified memory zone
<code>__memorySave</code>	Saves the contents of a specified memory area to a file
<code>__messageBoxYesCancel</code>	Displays a Yes/Cancel dialog box for user interaction
<code>__messageBoxYesNo</code>	Displays a Yes/No dialog box for user interaction
<code>__openFile</code>	Opens a file for I/O operations
<code>__orderInterrupt</code>	Generates an interrupt
<code>__popSimulatorInterruptExecutingStack</code>	Informs the interrupt simulation system that an interrupt handler has finished executing
<code>__readFile</code>	Reads from the specified file
<code>__readFileByte</code>	Reads one byte from the specified file
<code>__readMemory8,</code> <code>__readMemoryByte</code>	Reads one byte from the specified memory location
<code>__readMemory16</code>	Reads two bytes from the specified memory location
<code>__readMemory32</code>	Reads four bytes from the specified memory location
<code>__registerMacroFile</code>	Registers macros from the specified file
<code>__resetFile</code>	Rewinds a file opened by <code>__openFile</code>

Table 17: Summary of system macros (Continued)

Macro	Description
<code>__selectCore</code>	Only for use with IAR Embedded Workbench products that support multicore debugging
<code>__setAdvancedTriggerBreak</code>	Sets an advanced trigger breakpoint
<code>__setCodeBreak</code>	Sets a code breakpoint
<code>__setConditionalBreak</code>	Sets a conditional breakpoint
<code>__setDataBreak</code>	Sets a data breakpoint
<code>__setDataLogBreak</code>	Sets a data log breakpoint
<code>__setLogBreak</code>	Sets a log breakpoint
<code>__setRangeBreak</code>	Sets a range breakpoint
<code>__setSimBreak</code>	Sets a simulation breakpoint
<code>__setTraceStartBreak</code>	Sets a trace start breakpoint
<code>__setTraceStopBreak</code>	Sets a trace stop breakpoint
<code>__sourcePosition</code>	Returns the file name and source location if the current execution location corresponds to a source location
<code>__strFind</code>	Searches a given string for the occurrence of another string
<code>__subString</code>	Extracts a substring from another string
<code>__system1</code>	Starts an external application
<code>__system2</code>	Starts an external application with <code>stdout</code> and <code>stderr</code> collected in one variable
<code>__system3</code>	Starts an external application with <code>stdout</code> and <code>stderr</code> collected in separate variables
<code>__targetDebuggerVersion</code>	Returns the version of the target debugger
<code>__toLower</code>	Returns a copy of the parameter string where all the characters have been converted to lower case
<code>__toString</code>	Prints strings
<code>__toUpper</code>	Returns a copy of the parameter string where all the characters have been converted to upper case
<code>__unloadImage</code>	Unloads a debug image
<code>__wallTime_ms</code>	Returns the current host computer CPU time in milliseconds
<code>__writeFile</code>	Writes to the specified file
<code>__writeFileByte</code>	Writes one byte to the specified file

Table 17: Summary of system macros (Continued)

Macro	Description
<code>__writeMemory8,</code> <code>__writeMemoryByte</code>	Writes one byte to the specified memory location
<code>__writeMemory16</code>	Writes a two-byte word to the specified memory location
<code>__writeMemory32</code>	Writes a four-byte word to the specified memory location

Table 17: Summary of system macros (Continued)

__abortLaunch

Syntax	<code>__abortLaunch(message)</code>
Parameters	<i>message</i> A string that is printed as an error message when the macro executes.
Return value	None.
For use with	All C-SPY drivers.
Description	This macro can be used for aborting a debugger launch, for example if another macro sees that something goes wrong during initialization and cannot perform a proper setup. This is an emergency stop when launching, not a way to end an ongoing debug session like the C library function <code>abort()</code> .
Example	<pre>if (!__messageBoxYesCancel("Do you want to mass erase to unlock the device?", "Unlocking device")) { __abortLaunch("Unlock canceled. Debug session cannot continue."); }</pre>

__cancelAllInterrupts

Syntax	<code>__cancelAllInterrupts()</code>
Return value	<code>int 0</code>
For use with	The C-SPY Simulator.
Description	Cancels all ordered interrupts.

__cancelInterrupt

Syntax `__cancelInterrupt(interrupt_id)`

Parameters *interrupt_id*
The value returned by the corresponding `__orderInterrupt` macro call (unsigned long).

Return value

Result	Value
Successful	int 0
Unsuccessful	Non-zero error number

Table 18: `__cancelInterrupt` return values

For use with The C-SPY Simulator.

Description Cancels the specified interrupt.

__clearBreak

Syntax `__clearBreak(break_id)`

Parameters *break_id*
The value returned by any of the set breakpoint macros.

Return value int 0

For use with All C-SPY drivers.

Description Clears a user-defined breakpoint.

See also *Breakpoints*, page 107.

__closeFile

Syntax `__closeFile(fileHandle)`

Parameters *fileHandle*
A macro variable used as filehandle by the `__openFile` macro.

Return value int 0

For use with All C-SPY drivers.

Description Closes a file previously opened by `__openFile`.

`__delay`

Syntax `__delay(value)`

Parameters *value*
The number of milliseconds to delay execution.

Return value `int 0`

For use with All C-SPY drivers.

Description Delays execution the specified number of milliseconds.

`__disableInterrupts`

Syntax `__disableInterrupts()`

Return value

Result	Value
Successful	<code>int 0</code>
Unsuccessful	Non-zero error number

Table 19: `__disableInterrupts` return values

For use with The C-SPY Simulator.

Description Disables the generation of interrupts.

`__driverType`

Syntax `__driverType(driver_id)`

Parameters

driver_id

A string corresponding to the driver you want to check for. Choose one of these:

"`sim`" corresponds to the simulator driver

"`fet`" corresponds to the C-SPY FET Debugger driver

Return value

Result	Value
Successful	1
Unsuccessful	0

Table 20: `__driverType` return values

For use with

All C-SPY drivers.

Description

Checks to see if the current C-SPY driver is identical to the driver type of the `driver_id` parameter.

Example

`__driverType("sim")`

If the simulator is the current driver, the value 1 is returned. Otherwise 0 is returned.

`__enableInterrupts`

Syntax

`__enableInterrupts()`

Return value

Result	Value
Successful	int 0
Unsuccessful	Non-zero error number

Table 21: `__enableInterrupts` return values

For use with

The C-SPY Simulator.

Description

Enables the generation of interrupts.

`__evaluate`

Syntax

`__evaluate(string, valuePtr)`

Parameters

`string`

Expression string.

`valuePtr`

Pointer to a macro variable storing the result.

Return value

Result	Value
Successful	int 0
Unsuccessful	int 1

Table 22: `__evaluate` return values

For use with

All C-SPY drivers.

Description

This macro interprets the input string as an expression and evaluates it. The result is stored in a variable pointed to by *valuePtr*.

Example

This example assumes that the variable *i* is defined and has the value 5:

```
__evaluate("i + 3", &myVar)
```

The macro variable `myVar` is assigned the value 8.

`__fillMemory8`

Syntax

```
__fillMemory8(value, address, zone, length, format)
```

Parameters

value

An integer that specifies the value.

address

An integer that specifies the memory start address.

zone

A string that specifies the memory zone, see *C-SPY memory zones*, page 142.

length

An integer that specifies how many bytes are affected.

format

A string that specifies the exact fill operation to perform. Choose between:

Copy

value will be copied to the specified memory area.

AND

An AND operation will be performed between *value* and the existing contents of memory before writing the result to memory.

OR

An OR operation will be performed between *value* and the existing contents of memory before writing the result to memory.

	XOR	An XOR operation will be performed between <i>value</i> and the existing contents of memory before writing the result to memory.
Return value	int 0	
For use with	All C-SPY drivers.	
Description	Fills a specified memory area with a byte value.	
Example	<code>__fillMemory8(0x80, 0x700, "Memory", 0x10, "OR");</code>	

__fillMemory16

Syntax	<code>__fillMemory16(<i>value</i>, <i>address</i>, <i>zone</i>, <i>length</i>, <i>format</i>)</code>	
Parameters	<i>value</i>	An integer that specifies the value.
	<i>address</i>	An integer that specifies the memory start address.
	<i>zone</i>	A string that specifies the memory zone, see <i>C-SPY memory zones</i> , page 142.
	<i>length</i>	An integer that defines how many 2-byte entities to be affected.
	<i>format</i>	A string that specifies the exact fill operation to perform. Choose between:
	Copy	<i>value</i> will be copied to the specified memory area.
	AND	An AND operation will be performed between <i>value</i> and the existing contents of memory before writing the result to memory.
	OR	An OR operation will be performed between <i>value</i> and the existing contents of memory before writing the result to memory.
	XOR	An XOR operation will be performed between <i>value</i> and the existing contents of memory before writing the result to memory.
Return value	int 0	
For use with	All C-SPY drivers.	

Description Fills a specified memory area with a 2-byte value.

Example `__fillMemory16(0xCDCD, 0x7000, "Memory", 0x200, "Copy");`

__fillMemory32

Syntax `__fillMemory32(value, address, zone, length, format)`

Parameters

value

An integer that specifies the value.

address

An integer that specifies the memory start address.

zone

A string that specifies the memory zone, see *C-SPY memory zones*, page 142.

length

An integer that defines how many 4-byte entities to be affected.

format

A string that specifies the exact fill operation to perform. Choose between:

<code>Copy</code>	<i>value</i> will be copied to the specified memory area.
<code>AND</code>	An AND operation will be performed between <i>value</i> and the existing contents of memory before writing the result to memory.
<code>OR</code>	An OR operation will be performed between <i>value</i> and the existing contents of memory before writing the result to memory.
<code>XOR</code>	An XOR operation will be performed between <i>value</i> and the existing contents of memory before writing the result to memory.

Return value `int 0`

For use with All C-SPY drivers.

Description Fills a specified memory area with a 4-byte value.

Example `__fillMemory32(0x0000FFFF, 0x4000, "Memory", 0x1000, "XOR");`

__getSelectedCore

Description This macro returns 0 for a single-core system. It is only useful for IAR Embedded Workbench products that support multicore debugging

__isBatchMode

Syntax `__isBatchMode()`

Return value

Result	Value
True	int 1
False	int 0

Table 23: `__isBatchMode` return values

For use with All C-SPY drivers.

Description This macro returns True if the debugger is running in batch mode, otherwise it returns False.

__loadImage

Syntax `__loadImage(path, offset, debugInfoOnly)`

Parameters

path

A string that identifies the path to the debug image to download. The path must either be absolute or use argument variables. For information about argument variables, see the *IDE Project Management and Building Guide for MSP430*.

offset

An integer that identifies the offset to the destination address for the downloaded debug image.

debugInfoOnly

A non-zero integer value if no code or data should be downloaded to the target system, which means that C-SPY will only read the debug information from the debug file. Or, 0 (zero) for download.

Return value

Value	Result
Non-zero integer number	A unique module identification.

Table 24: `__loadImage` return values

Value	Result
int 0	Loading failed.

Table 24: `__loadImage` return values (Continued)

For use with	All C-SPY drivers.
Description	Loads a debug image (debug file).
Example 1	<p>Your system consists of a ROM library and an application. The application is your active project, but you have a debug file corresponding to the library. In this case you can add this macro call in the <code>execUserSetup</code> macro in a C-SPY macro file, which you associate with your project:</p> <pre>__loadImage("ROMfile", 0x8000, 1);</pre> <p>This macro call loads the debug information for the ROM library <i>ROMfile</i> without downloading its contents (because it is presumably already in ROM). Then you can debug your application together with the library.</p>
Example 2	<p>Your system consists of a ROM library and an application, but your main concern is the library. The library needs to be programmed into flash memory before a debug session. While you are developing the library, the library project must be the active project in the IDE. In this case you can add this macro call in the <code>execUserSetup</code> macro in a C-SPY macro file, which you associate with your project:</p> <pre>__loadImage("ApplicationFile", 0x8000, 0);</pre> <p>The macro call loads the debug information for the application and downloads its contents (presumably into RAM). Then you can debug your library together with the application.</p>
See also	<i>Images</i> , page 403 and <i>Loading multiple debug images</i> , page 47.

`__memoryRestore`

Syntax	<code>__memoryRestore(zone, filename)</code>
Parameters	<p><i>zone</i></p> <p>A string that specifies the memory zone, see <i>C-SPY memory zones</i>, page 142.</p>

	<i>filename</i>
	A string that specifies the file to be read. The filename must include a path, which must either be absolute or use argument variables. For information about argument variables, see the <i>IDE Project Management and Building Guide for MSP430</i> .
Return value	int 0
For use with	All C-SPY drivers.
Description	Reads the contents of a file and saves it to the specified memory zone.
Example	<code>__memoryRestore("Memory", "c:\\temp\\saved_memory.hex");</code>
See also	<i>Memory Restore dialog box</i> , page 154.

__memorySave

Syntax	<code>__memorySave(start, stop, format, filename)</code>
Parameters	<p><i>start</i></p> <p>A string that specifies the first location of the memory area to be saved.</p> <p><i>stop</i></p> <p>A string that specifies the last location of the memory area to be saved.</p> <p><i>format</i></p> <p>A string that specifies the format to be used for the saved memory. Choose between:</p> <p>intel-extended</p> <p>motorola</p> <p>motorola-s19</p> <p>motorola-s28</p> <p>motorola-s37</p> <p>msp430-txt-format</p>

	<i>filename</i>
	A string that specifies the file to write to. The filename must include a path, which must either be absolute or use argument variables. For information about argument variables, see the <i>IDE Project Management and Building Guide for MSP430</i> .
Return value	int 0
For use with	All C-SPY drivers.
Description	Saves the contents of a specified memory area to a file.
Example	<pre>__memorySave("Memory:0x00", "Memory:0xFF", "intel-extended", "c:\\temp\\saved_memory.hex");</pre>
See also	<i>Memory Save dialog box</i> , page 153.

__messageBoxYesCancel

Syntax	<code>__messageBoxYesCancel(<i>message</i>, <i>caption</i>)</code>						
Parameters	<p><i>message</i></p> <p>A message that will appear in the message box.</p> <p><i>caption</i></p> <p>The title that will appear in the message box.</p>						
Return value	<table border="1"> <thead> <tr> <th>Result</th> <th>Value</th> </tr> </thead> <tbody> <tr> <td>Yes</td> <td>1</td> </tr> <tr> <td>No</td> <td>0</td> </tr> </tbody> </table> <p><i>Table 25: __messageBoxYesCancel return values</i></p>	Result	Value	Yes	1	No	0
Result	Value						
Yes	1						
No	0						
For use with	All C-SPY drivers.						
Description	Displays a Yes/Cancel dialog box when called and returns the user input. Typically, this is useful for creating macros that require user interaction.						

__messageBoxYesNo

Syntax `__messageBoxYesNo(message, caption)`

Parameters *message*

A message that will appear in the message box.

caption

The title that will appear in the message box.

Return value

Result	Value
Yes	1
No	0

Table 26: __messageBoxYesNo return values

For use with All C-SPY drivers.

Description Displays a Yes/No dialog box when called and returns the user input. Typically, this is useful for creating macros that require user interaction.

__openFile

Syntax `__openFile(filename, access)`

Parameters *filename*

The file to be opened. The filename must include a path, which must either be absolute or use argument variables. For information about argument variables, see the *IDE Project Management and Building Guide for MSP430*.

access

The access type (string).

These are mandatory but mutually exclusive:

"a" append, new data will be appended at the end of the open file

"r" read (by default in text mode; combine with b for binary mode: rb)

"w" write (by default in text mode; combine with b for binary mode: wb)

These are optional and mutually exclusive:

"b" binary, opens the file in binary mode

"t" ASCII text, opens the file in text mode

This access type is optional:

"+" together with r, w, or a; r+ or w+ is *read* and *write*, while a+ is *read* and *append*

Return value

Result	Value
Successful	The file handle
Unsuccessful	An invalid file handle, which tests as False

Table 27: `__openFile` return values

For use with

All C-SPY drivers.

Description

Opens a file for I/O operations. The default base directory of this macro is where the currently open project file (*.ewp) is located. The argument to `__openFile` can specify a location relative to this directory. In addition, you can use argument variables such as `$PROJ_DIR$` and `$TOOLKIT_DIR$` in the path argument.

Example

```
__var myFileHandle;          /* The macro variable to contain */
                             /* the file handle */
myFileHandle = __openFile("$PROJ_DIR$\Debug\Exe\test.tst",
"r");
if (myFileHandle)
{
    /* successful opening */
}
```

See also

For information about argument variables, see the *IDE Project Management and Building Guide for MSP430*.

`__orderInterrupt`

Syntax

```
__orderInterrupt(specification, first_activation,
                repeat_interval, variance, infinite_hold_time,
                hold_time, probability)
```

Parameters

specification

The interrupt (string). The specification can either be the full specification used in the device description file (ddf) or only the name. In the latter case the interrupt system will automatically get the description from the device description file.

	<i>first_activation</i>	The first activation time in cycles (integer)
	<i>repeat_interval</i>	The periodicity in cycles (integer)
	<i>variance</i>	The timing variation range in percent (integer between 0 and 100)
	<i>infinite_hold_time</i>	1 if infinite, otherwise 0.
	<i>hold_time</i>	The hold time (integer)
	<i>probability</i>	The probability in percent (integer between 0 and 100)
Return value		The macro returns an interrupt identifier (unsigned long). If the syntax of <i>specification</i> is incorrect, it returns -1.
For use with		The C-SPY Simulator.
Description		Generates an interrupt.
Example		This example generates a repeating interrupt using an infinite hold time first activated after 4000 cycles: <pre>__orderInterrupt("USART0RX_VECTOR", 4000, 2000, 0, 1, 0, 100);</pre>

__popSimulatorInterruptExecutingStack

Syntax	<code>__popSimulatorInterruptExecutingStack(void)</code>
Return value	<code>int 0</code>
For use with	The C-SPY Simulator.
Description	<p>Informs the interrupt simulation system that an interrupt handler has finished executing, as if the normal instruction used for returning from an interrupt handler was executed.</p> <p>This is useful if you are using interrupts in such a way that the normal instruction for returning from an interrupt handler is not used, for example in an operating system with</p>

task-switching. In this case, the interrupt simulation system cannot automatically detect that the interrupt has finished executing.

See also

Simulating an interrupt in a multi-task system, page 273.

__readFile

Syntax

```
__readFile(fileHandle, valuePtr)
```

Parameters

fileHandle

A macro variable used as filehandle by the `__openFile` macro.

valuePtr

A pointer to a variable.

Return value

Result	Value
Successful	0
Unsuccessful	Non-zero error number

Table 28: `__readFile` return values

For use with

All C-SPY drivers.

Description

Reads a sequence of hexadecimal digits from the given file and converts them to an `unsigned long` which is assigned to the *value* parameter, which should be a pointer to a macro variable.

Only printable characters representing hexadecimal digits and white-space characters are accepted, no other characters are allowed.

Example

```
__var number;
if (__readFile(myFileHandle, &number) == 0)
{
    // Do something with number
}
```

In this example, if the file pointed to by `myFileHandle` contains the ASCII characters `1234 abcd 90ef`, consecutive reads will assign the values `0x1234 0xabcd 0x90ef` to the variable `number`.

__readFileByte

Syntax	<code>__readFileByte(<i>fileHandle</i>)</code>
Parameters	<i>fileHandle</i> A macro variable used as filehandle by the <code>__openFile</code> macro.
Return value	-1 upon error or end-of-file, otherwise a value between 0 and 255.
For use with	All C-SPY drivers.
Description	Reads one byte from a file.
Example	<pre>__var byte; while ((byte = __readFileByte(myFileHandle)) != -1) { /* Do something with byte */ }</pre>

__readMemory8, __readMemoryByte

Syntax	<code>__readMemory8(<i>address</i>, <i>zone</i>)</code> <code>__readMemoryByte(<i>address</i>, <i>zone</i>)</code>
Parameters	<i>address</i> The memory address (integer). <i>zone</i> A string that specifies the memory zone, see <i>C-SPY memory zones</i> , page 142.
Return value	The macro returns the value from memory.
For use with	All C-SPY drivers.
Description	Reads one byte from a given memory location.
Example	<code>__readMemory8(0x0108, "Memory");</code>

__readMemory16

Syntax	<code>__readMemory16(address, zone)</code>
Parameters	<p><i>address</i></p> <p>The memory address (integer).</p> <p><i>zone</i></p> <p>A string that specifies the memory zone, see <i>C-SPY memory zones</i>, page 142.</p>
Return value	The macro returns the value from memory.
For use with	All C-SPY drivers.
Description	Reads a two-byte word from a given memory location.
Example	<code>__readMemory16(0x0108, "Memory");</code>

__readMemory32

Syntax	<code>__readMemory32(address, zone)</code>
Parameters	<p><i>address</i></p> <p>The memory address (integer).</p> <p><i>zone</i></p> <p>A string that specifies the memory zone, see <i>C-SPY memory zones</i>, page 142.</p>
Return value	The macro returns the value from memory.
For use with	All C-SPY drivers.
Description	Reads a four-byte word from a given memory location.
Example	<code>__readMemory32(0x0108, "Memory");</code>

__registerMacroFile

Syntax	<code>__registerMacroFile(<i>filename</i>)</code>
Parameters	<p><i>filename</i></p> <p>A file containing the macros to be registered (string). The filename must include a path, which must either be absolute or use argument variables. For information about argument variables, see the <i>IDE Project Management and Building Guide for MSP430</i>.</p>
Return value	<code>int 0</code>
For use with	All C-SPY drivers.
Description	Registers macros from a setup macro file. With this function you can register multiple macro files during C-SPY startup.
Example	<code>__registerMacroFile("c:\\testdir\\macro.mac");</code>
See also	<i>Using C-SPY macros</i> , page 313.

__resetFile

Syntax	<code>__resetFile(<i>fileHandle</i>)</code>
Parameters	<p><i>fileHandle</i></p> <p>A macro variable used as filehandle by the <code>__openFile</code> macro.</p>
Return value	<code>int 0</code>
For use with	All C-SPY drivers.
Description	Rewinds a file previously opened by <code>__openFile</code> .

__selectCore

Description	This macro can only be used with IAR Embedded Workbench products that support multicore debugging.
-------------	--

__setAdvancedTriggerBreak

Syntax	<code>__setAdvancedTriggerBreak(<i>type</i>, <i>condition</i>, <i>access</i>, <i>action</i>, <i>mask</i> <i>cond_value</i>)</code>
Parameters	All parameters are strings.
	<i>type</i> The breakpoint type: "Address", "Data", or "Register".
	<i>condition</i> The breakpoint condition operator: "==", ">=", "<=", or "!=".
	<i>access</i> The memory access type. Choose between:
	"Read"
	"Write"
	"ReadWrite"
	"Fetch"
	"FetchHold"
	"NoFetch"
	"NoFetchRead"
	"NoFetchNoDMA"
	"DMA"
	"NoDMA"
	"WriteNoDMA"
	"NoFetchReadNoDMA"
	"ReadNoDMA"
	"ReadDMA"
	"WriteDMA"
	<i>action</i> The action type: "Break", "Trigger", or "BreakTrigger".
	<i>mask</i> A 16-bit value that the breakpoint address or value will be masked with.
	<i>cond_value</i> An extra conditional data value.

Return value

Result	Value
Successful	An unsigned integer uniquely identifying the breakpoint. This value must be used to clear the breakpoint.
Unsuccessful	0

Table 29: `__setAdvancedTriggerBreak` return values

For use with

The C-SPY FET Debugger driver.

Description

Sets an advanced trigger breakpoint.

Example

```
__var brk;
brk = __setAdvancedTriggerBreak("Register", ">=", "Write",
                                "Trigger", "0x0000", "0x4000");
...
__clearBreak(brk);
```

See also

Breakpoints, page 107.

`__setCodeBreak`

Syntax

`__setCodeBreak(location, count, condition, cond_type, action)`

Parameters

location

A string that defines the code location of the breakpoint, either a valid C-SPY expression whose value evaluates to a valid address, an absolute location, or a source location. For more information about the location types, see *Enter Location dialog box*, page 136.

count

The number of times that a breakpoint condition must be fulfilled before a break occurs (integer).

condition

The breakpoint condition. This must be a valid C-SPY expression, for instance a C-SPY macro function.

cond_type

The condition type; either "CHANGED" or "TRUE" (string).

action

An expression, typically a call to a macro, which is evaluated when the breakpoint is detected.

Return value

Result	Value
Successful	An unsigned integer uniquely identifying the breakpoint. This value must be used to clear the breakpoint.
Unsuccessful	0

Table 30: `__setCodeBreak` return values

For use with

All C-SPY drivers.

Description

Sets a code breakpoint, that is, a breakpoint which is triggered just before the processor fetches an instruction at the specified location.

Examples

```
__setCodeBreak("D:\\src\\prog.c}.12.9", 3, "d>16", "TRUE",
"ActionCode()");
```

This example sets a code breakpoint on the label `main` in your source:

```
__setCodeBreak("main", 0, "1", "TRUE", "");
```

See also

Breakpoints, page 107.**`__setConditionalBreak`**

Syntax

```
__setConditionalBreak(location, type, operator, access, action,
                    mask, cond_value, cond_operator,
                    cond_access, cond_mask)
```

Parameters

All parameters are strings.

location

The breakpoint location. Choose between:

A *source location* on the form "`{filename}.line.col`" (for example "`{D:\\src\\prog.c}.12.9`")

An *absolute location* on the form "`zone:hexaddress`" or simply "`hexaddress`" (for example "`Memory:0x42`")

An *expression* whose value designates a location (for example "`my_global_variable`").

A *register* (for example "`R10`")

type

The breakpoint type: "Address", "Data", or "Register".

operator

The breakpoint operator: "=", ">=", "<=", or "!=".

<i>access</i>	The memory access type: "Read", "Write", "ReadWrite", or "Fetch".
<i>action</i>	The action type: "Break", "Trigger", or "BreakTrigger".
<i>mask</i>	A 16-bit value that the breakpoint address or value will be masked with.
<i>cond_value</i>	An extra conditional data value.
<i>cond_operator</i>	The condition operator: "==", ">=", "<=", or "!=".
<i>cond_access</i>	The access type of the condition: "Read" or "Write".
<i>cond_mask</i>	The mask value of the condition.

Return value

Result	Value
Successful	An unsigned integer uniquely identifying the breakpoint. This value must be used to clear the breakpoint.
Unsuccessful	0

Table 31: *__setConditionalBreak* return values

For use with

The C-SPY FET Debugger driver.

Description

Sets a conditional breakpoint.

Example

```
__var brk;
brk = __setConditionalBreak("R10", "Register", "0x5000", ">=",
    "Write", "Trigger", "0x0000", "0x4000", "<=", "Write",
    "0x00FF");
...
__clearBreak(brk);
```

See also

Breakpoints, page 107.

`__setDataBreak`

Syntax

```
__setDataBreak(location, count, condition, cond_type, access,
    action)
```

Parameters	<p><i>location</i></p> <p>A string that defines the data location of the breakpoint, either a valid C-SPY expression whose value evaluates to a valid address or an absolute location. For information about the location types, see <i>Enter Location dialog box</i>, page 136.</p> <p><i>count</i></p> <p>The number of times that a breakpoint condition must be fulfilled before a break occurs (integer).</p> <p><i>condition</i></p> <p>The breakpoint condition (string).</p> <p><i>cond_type</i></p> <p>The condition type; either "CHANGED" or "TRUE" (string).</p> <p><i>access</i></p> <p>The memory access type: "R", for read, "W" for write, or "RW" for read/write.</p> <p><i>action</i></p> <p>An expression, typically a call to a macro, which is evaluated when the breakpoint is detected.</p>						
Return value	<table border="1"> <thead> <tr> <th>Result</th> <th>Value</th> </tr> </thead> <tbody> <tr> <td>Successful</td> <td>An unsigned integer uniquely identifying the breakpoint. This value must be used to clear the breakpoint.</td> </tr> <tr> <td>Unsuccessful</td> <td>0</td> </tr> </tbody> </table> <p><i>Table 32: __setDataBreak return values</i></p>	Result	Value	Successful	An unsigned integer uniquely identifying the breakpoint. This value must be used to clear the breakpoint.	Unsuccessful	0
Result	Value						
Successful	An unsigned integer uniquely identifying the breakpoint. This value must be used to clear the breakpoint.						
Unsuccessful	0						
For use with	The C-SPY Simulator.						
Description	Sets a data breakpoint, that is, a breakpoint which is triggered directly after the processor has read or written data at the specified location.						
Example	<pre>__var brk; brk = __setDataBreak("Memory:0x4710", 3, "d>6", "TRUE", "W", "ActionData()"); ... __clearBreak(brk);</pre>						
See also	<i>Breakpoints</i> , page 107.						

__setDataLogBreak

Syntax	<code>__setDataLogBreak(variable, access)</code>						
Parameters	<p><i>variable</i></p> <p>A string that defines the variable the breakpoint is set on, a variable of integer type with static storage duration. The microcontroller must also be able to access the variable with a single-instruction memory access, which means that you can only set data log breakpoints on 8-bit variables.</p> <p><i>access</i></p> <p>The memory access type: "R", for read, "W" for write, or "RW" for read/write.</p>						
Return value	<table border="1"> <thead> <tr> <th>Result</th> <th>Value</th> </tr> </thead> <tbody> <tr> <td>Successful</td> <td>An unsigned integer uniquely identifying the breakpoint. This value must be used to clear the breakpoint.</td> </tr> <tr> <td>Unsuccessful</td> <td>0</td> </tr> </tbody> </table> <p><i>Table 33: __setDataLogBreak return values</i></p>	Result	Value	Successful	An unsigned integer uniquely identifying the breakpoint. This value must be used to clear the breakpoint.	Unsuccessful	0
Result	Value						
Successful	An unsigned integer uniquely identifying the breakpoint. This value must be used to clear the breakpoint.						
Unsuccessful	0						
For use with	The C-SPY Simulator.						
Description	Sets a data log breakpoint, that is, a breakpoint which is triggered when a specified variable is accessed. Note that a data log breakpoint does not stop the execution, it just generates a data log.						
Example	<pre>__var brk; brk = __setDataLogBreak("MyVar", "R"); ... __clearBreak(brk);</pre>						
See also	<i>Breakpoints</i> , page 107 and <i>Getting started using data logging</i> , page 200.						

__setLogBreak

Syntax

```
__setLogBreak(location, message, msg_type, condition,
              cond_type)
```

Parameters

location

A string that defines the code location of the breakpoint, either a valid C-SPY expression whose value evaluates to a valid address, an absolute location, or a source location. For more information about the location types, see *Enter Location dialog box*, page 136.

message

The message text.

msg_type

The message type; choose between:

TEXT, the message is written word for word.

ARGS, the message is interpreted as a comma-separated list of C-SPY expressions or strings.

condition

The breakpoint condition (string).

cond_type

The condition type; either "CHANGED" or "TRUE" (string).

Return value

Result	Value
Successful	An unsigned integer uniquely identifying the breakpoint. The same value must be used when you want to clear the breakpoint.
Unsuccessful	0

Table 34: __setLogBreak return values

For use with

All C-SPY drivers.

Description

Sets a log breakpoint, that is, a breakpoint which is triggered when an instruction is fetched from the specified location. If you have set the breakpoint on a specific machine instruction, the breakpoint will be triggered and the execution will temporarily halt and print the specified message in the C-SPY **Debug Log** window.

Example

```

__var logBp1;
__var logBp2;

logOn()
{
    logBp1 = __setLogBreak ("{C:\\temp\\Utilities.c}.23.1",
        "\\Entering trace zone at :\\", #PC:%X", "ARGS", "1", "TRUE");
    logBp2 = __setLogBreak ("{C:\\temp\\Utilities.c}.30.1",
        "Leaving trace zone...", "TEXT", "1", "TRUE");
}

logOff()
{
    __clearBreak(logBp1);
    __clearBreak(logBp2);
}

```

See also

Formatted output, page 321 and *Breakpoints*, page 107.

__setRangeBreak

Syntax

```
__setRangeBreak(start_loc, end_loc, end_cond, type, access,
                action, action_when)
```

Parameters

All parameters are strings.

<i>start_loc</i>	The start location. Choose between: A <i>source location</i> on the form " <i>{filename}.line.col</i> " (for example " <i>{D:\\src\\prog.c}.12.9</i> ") An <i>absolute location</i> on the form " <i>zone:hexaddress</i> " or simply " <i>hexaddress</i> " (for example " <i>Memory:0x42</i> ") An <i>expression</i> whose value designates a location (for example " <i>my_global_variable</i> ").
<i>end_loc</i>	The end location. This can be either the same as for <i>start_loc</i> above or the length of the range.
<i>end_cond</i>	The type of end condition: "Location", "Length", or "Automatic".
<i>type</i>	The breakpoint type: "Address" or "Data".
<i>access</i>	The memory access type: "Read", "Write", "ReadWrite", or "Fetch".

action The action type: "Break", "Trigger", or "BreakTrigger".

action_when Specifies if the action should happen at an access inside or outside of the specified range: "Inside" or "Outside".

Return value

Result	Value
Successful	An unsigned integer uniquely identifying the breakpoint. This value must be used to clear the breakpoint.
Unsuccessful	0

Table 35: `__setRangeBreak` return values

For use with

The C-SPY FET Debugger driver.

Description

Sets a range breakpoint.

Example

```
__var brk;
brk = __setRangeBreak("Memory:0x1240", "Memory:0x1360",
    "Location", "Address", "Fetch", "Trigger", "Inside");
...
__clearBreak(brk);
```

See also

Breakpoints, page 107.

`__setSimBreak`

Syntax

`__setSimBreak(location, access, action)`

Parameters

location

A string that defines the data location of the breakpoint, either a valid C-SPY expression whose value evaluates to a valid address or an absolute location. For information about the location types, see *Enter Location dialog box*, page 136.

access

The memory access type: "R" for read or "W" for write.

action

An expression, typically a call to a macro, which is evaluated when the breakpoint is detected.

Return value

Result	Value
Successful	An unsigned integer uniquely identifying the breakpoint. This value must be used to clear the breakpoint.
Unsuccessful	0

Table 36: `__setSimBreak` return values

For use with

The C-SPY Simulator.

Description

Use this system macro to set *immediate* breakpoints, which will halt instruction execution only temporarily. This allows a C-SPY macro function to be called when the processor is about to read data from a location or immediately after it has written data. Instruction execution will resume after the action.

This type of breakpoint is useful for simulating memory-mapped devices of various kinds (for instance serial ports and timers). When the processor reads at a memory-mapped location, a C-SPY macro function can intervene and supply the appropriate data. Conversely, when the processor writes to a memory-mapped location, a C-SPY macro function can act on the value that was written.

`__setTraceStartBreak`

Syntax

`__setTraceStartBreak(location)`

Parameters

location

A string that defines the code location of the breakpoint, either a valid C-SPY expression whose value evaluates to a valid address, an absolute location, or a source location. For more information about the location types, see *Enter Location dialog box*, page 136.

Return value

Result	Value
Successful	An unsigned integer uniquely identifying the breakpoint. The same value must be used when you want to clear the breakpoint.
Unsuccessful	0

Table 37: `__setTraceStartBreak` return values

For use with

The C-SPY Simulator.

Description

Sets a breakpoint at the specified location. When that breakpoint is triggered, the trace system is started.

Example

```

__var startTraceBp;
__var stopTraceBp;

traceOn()
{
    startTraceBp = __setTraceStartBreak
        ("C:\\TEMP\\Utilities.c).23.1");
    stopTraceBp = __setTraceStopBreak
        ("C:\\temp\\Utilities.c).30.1");
}

traceOff()
{
    __clearBreak(startTraceBp);
    __clearBreak(stopTraceBp);
}

```

See also

Trace Start Trigger breakpoint dialog box, page 189.

__setTraceStopBreak

Syntax

```
__setTraceStopBreak(location)
```

Parameters

location

A string that defines the code location of the breakpoint, either a valid C-SPY expression whose value evaluates to a valid address, an absolute location, or a source location. For more information about the location types, see *Enter Location dialog box*, page 136.

Return value

Result	Value
Successful	An unsigned integer uniquely identifying the breakpoint. The same value must be used when you want to clear the breakpoint.
Unsuccessful	int 0

Table 38: __setTraceStopBreak return values

For use with

The C-SPY Simulator.

Description

Sets a breakpoint at the specified location. When that breakpoint is triggered, the trace system is stopped.

Example

See *__setTraceStartBreak*, page 355.

See also

Trace Stop Trigger breakpoint dialog box, page 190.

__sourcePosition

Syntax

```
__sourcePosition(linePtr, colPtr)
```

Parameters

linePtr

Pointer to the variable storing the line number

colPtr

Pointer to the variable storing the column number

Return value

Result	Value
Successful	Filename string
Unsuccessful	Empty (" ") string

Table 39: __sourcePosition return values

For use with

All C-SPY drivers.

Description

If the current execution location corresponds to a source location, this macro returns the filename as a string. It also sets the value of the variables, pointed to by the parameters, to the line and column numbers of the source location.

__strFind

Syntax

```
__strFind(macroString, pattern, position)
```

Parameters

macroString

A macro string.

pattern

The string pattern to search for

position

The position where to start the search. The first position is 0

Return value

The position where the pattern was found or -1 if the string is not found.

For use with

All C-SPY drivers.

Description	This macro searches a given string (<i>macroString</i>) for the occurrence of another string (<i>pattern</i>).
Example	<pre>__strFind("Compiler", "pile", 0) = 3 __strFind("Compiler", "foo", 0) = -1</pre>
See also	<i>Macro strings</i> , page 319.

__subString

Syntax	<code>__subString(<i>macroString</i>, <i>position</i>, <i>length</i>)</code>
Parameters	<p><i>macroString</i></p> <p>A macro string.</p> <p><i>position</i></p> <p>The start position of the substring. The first position is 0.</p> <p><i>length</i></p> <p>The length of the substring</p>
Return value	A substring extracted from the given macro string.
For use with	All C-SPY drivers.
Description	This macro extracts a substring from another string (<i>macroString</i>).
Example	<pre>__subString("Compiler", 0, 2)</pre> <p>The resulting macro string contains Co.</p> <pre>__subString("Compiler", 3, 4)</pre> <p>The resulting macro string contains pile.</p>
See also	<i>Macro strings</i> , page 319.

__system l

Syntax	<code>__systeml(<i>string</i>)</code>
Parameters	<p><i>string</i></p> <p>The command line used to start an external application.</p>

Return value	The exit code returned from the external application. If the application could not be launched or fails to return an appropriate exit code, 1 is returned.
For use with	All C-SPY drivers.
Description	This macro launches an external application. It ignores all output returned from the application. Terminates the launched application if the application has not finished within 10 seconds.
Example	<pre>__var exitCode; exitCode = __system1("mkdir tmp");</pre>

__system2

Syntax	<code>__system2(<i>string</i>, &<i>output</i>)</code>
Parameters	<p><i>string</i></p> <p>The command line used to start an external application.</p> <p><i>output</i></p> <p>The output returned from the application. Both the <code>stdout</code> and the <code>stderr</code> streams are stored in this variable.</p>
Return value	The exit code returned from the external application. If the application could not be launched or fails to return an appropriate exit code, 1 is returned.
For use with	All C-SPY drivers.
Description	This macro launches an external application. The output from both the <code>stdout</code> and the <code>stderr</code> streams is stored in <i>output</i> . If no data has been received from the launched application within 10 seconds, or when the returned data exceeds 65535 bytes, the application is terminated. This restriction prevents the Embedded Workbench IDE from freezing or crashing because of misbehaving applications.
Example	<pre>__var exitCode; __var out_err; exitCode = __system2("dir /S", &out_err); message "Output from the dir command:"; message out_err;</pre>

__system3

Syntax	<code>__system3(<i>string</i>, &<i>output</i>, &<i>error</i>)</code>
Parameters	<p><i>string</i></p> <p>The command line used to start an external application.</p> <p><i>output</i></p> <p>The output returned from the <code>stdout</code> output stream of the application.</p> <p><i>error</i></p> <p>The output returned from the <code>stderr</code> output stream of the application.</p>
Return value	The exit code returned from the external application. If the application could not be launched or fails to return an appropriate exit code, 1 is returned.
For use with	All C-SPY drivers.
Description	This macro launches an external application. The output from the <code>stdout</code> stream is stored in <i>output</i> and the <code>stderr</code> stream is stored in <i>error</i> . If no data has been received from the launched application within 10 seconds, or when the returned data exceeds 65535 bytes, the application is terminated. This restriction prevents the Embedded Workbench IDE from freezing or crashing because of misbehaving applications.
Example	<pre> __var exitCode; __var out; __var err; exitCode = __system3("dir /S", &out, &err); message "Output from the dir command:"; message out; message "Error text from the dir command:"; message err; </pre>

__targetDebuggerVersion

Syntax	<code>__targetDebuggerVersion()</code>
Return value	A string that represents the version number of the C-SPY debugger processor module.
For use with	All C-SPY drivers.

Description This macro returns the version number of the C-SPY debugger processor module.

Example

```
__var toolVer;
toolVer = __targetDebuggerVersion();
__message "The target debugger version is, ", toolVer;
```

__toLower

Syntax `__toLower(macroString)`

Parameters *macroString*

A macro string.

Return value The converted macro string.

For use with All C-SPY drivers.

Description This macro returns a copy of the parameter *macroString* where all the characters have been converted to lower case.

Example

```
__toLower("IAR")
The resulting macro string contains iar.
__toLower("Mix42")
The resulting macro string contains mix42.
```

See also *Macro strings*, page 319.

__toString

Syntax `__toString(C_string, maxlength)`

Parameters *C_string*

Any null-terminated C string.

maxlength

The maximum length of the returned macro string.

Return value Macro string.

For use with All C-SPY drivers.

Description	This macro is used for converting C strings (<code>char*</code> or <code>char[]</code>) into macro strings.
Example	Assuming your application contains this definition: <pre>char const * hptr = "Hello World!";</pre> this macro call: <pre>__toString(hptr, 5)</pre> would return the macro string containing <code>Hello</code> .
See also	<i>Macro strings</i> , page 319.

__ToUpper

Syntax	<code>__ToUpper(<i>macroString</i>)</code>
Parameters	<i>macroString</i> A macro string.
Return value	The converted string.
For use with	All C-SPY drivers.
Description	This macro returns a copy of the parameter <i>macroString</i> where all the characters have been converted to upper case.
Example	<pre>__ToUpper("string")</pre> The resulting macro string contains <code>STRING</code> .
See also	<i>Macro strings</i> , page 319.

__unloadImage

Syntax	<code>__unloadImage(<i>module_id</i>)</code>
Parameters	<i>module_id</i> An integer which represents a unique module identification, which is retrieved as a return value from the corresponding <code>__loadImage</code> C-SPY macro.

Return value

Value	Result
<i>module_id</i>	A unique module identification (the same as the input parameter).
int 0	The unloading failed.

Table 40: *__unloadImage* return values

For use with

All C-SPY drivers.

Description

Unloads debug information from an already downloaded debug image.

See also

Loading multiple debug images, page 47 and *Images*, page 403.

__wallTime_ms

Syntax

`__wallTime_ms()`

Return value

Returns the current host computer CPU time in milliseconds.

For use with

All C-SPY drivers.

Description

This macro returns the current host computer CPU time in milliseconds. The first call will always return 0.

Example

```
__var t1;
__var t2;

t1 = __wallTime_ms();
__var i;
for (i =0; i < 1000; i++)
    message "Tick";
t2 = __wallTime_ms();
message "Elapsed time: ", t2 - t1;
```

__writeFile

Syntax

`__writeFile(fileHandle, value)`

Parameters

*fileHandle*A macro variable used as filehandle by the `__openFile` macro.

	<i>value</i>
	An integer.
Return value	int 0
For use with	All C-SPY drivers.
Description	Prints the integer value in hexadecimal format (with a trailing space) to the file <i>file</i> . Note: The <code>__fmessage</code> statement can do the same thing. The <code>__writeFile</code> macro is provided for symmetry with <code>__readFile</code> .

__writeFileByte

Syntax	<code>__writeFileByte(<i>fileHandle</i>, <i>value</i>)</code>
Parameters	<i>fileHandle</i> A macro variable used as filehandle by the <code>__openFile</code> macro. <i>value</i> An integer.
Return value	int 0
For use with	All C-SPY drivers.
Description	Writes one byte to the file <i>fileHandle</i> .

__writeMemory8, __writeMemoryByte

Syntax	<code>__writeMemory8(<i>value</i>, <i>address</i>, <i>zone</i>)</code> <code>__writeMemoryByte(<i>value</i>, <i>address</i>, <i>zone</i>)</code>
Parameters	<i>value</i> An integer. <i>address</i> The memory address (integer). <i>zone</i> A string that specifies the memory zone, see <i>C-SPY memory zones</i> , page 142.
Return value	int 0

For use with	All C-SPY drivers.
Description	Writes one byte to a given memory location.
Example	<code>__writeMemory8(0x2F, 0x8020, "Memory");</code>

__writeMemory16

Syntax	<code>__writeMemory16(<i>value</i>, <i>address</i>, <i>zone</i>)</code>
Parameters	<p><i>value</i> An integer.</p> <p><i>address</i> The memory address (integer).</p> <p><i>zone</i> A string that specifies the memory zone, see <i>C-SPY memory zones</i>, page 142.</p>
Return value	<code>int 0</code>
For use with	All C-SPY drivers.
Description	Writes two bytes to a given memory location.
Example	<code>__writeMemory16(0x2FFF, 0x8020, "Memory");</code>

__writeMemory32

Syntax	<code>__writeMemory32(<i>value</i>, <i>address</i>, <i>zone</i>)</code>
Parameters	<p><i>value</i> An integer.</p> <p><i>address</i> The memory address (integer).</p> <p><i>zone</i> A string that specifies the memory zone, see <i>C-SPY memory zones</i>, page 142.</p>
Return value	<code>int 0</code>

For use with	All C-SPY drivers.
Description	Writes four bytes to a given memory location.
Example	<code>__writeMemory32(0x5555FFFF, 0x8020, "Memory");</code>

Graphical environment for macros

Reference information about:

- *Macro Registration window*, page 366
- *Debugger Macros window*, page 368
- *Macro Quicklaunch window*, page 370

Macro Registration window

The **Macro Registration** window is available from the **View>Macros** submenu during a debug session.

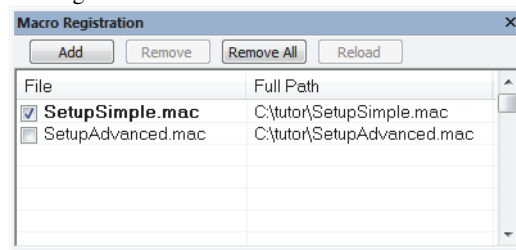

Use this window to list, register, and edit your debugger macro files.

Double-click a macro file to open it in the editor window and edit it.

See also *Registering C-SPY macros—an overview*, page 314.

Requirements

Can be used with all C-SPY debugger drivers and debug probes.

Display area

This area contains these columns:

File

The name of an available macro file. To register the macro file, select the check box to the left of the filename. The name of a registered macro file appears in bold style.

Full path

The path to the location of the added macro file.

Context menu

This context menu is available:

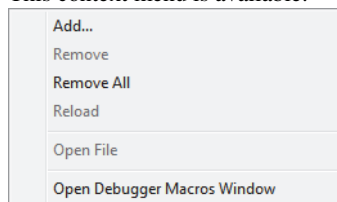

These commands are available:

Add

Opens a file browser where you can locate the macro file that you want to add to the list. This menu command is also available as a function button at the top of the window.

Remove

Removes the selected debugger macro file from the list. This menu command is also available as a function button at the top of the window.

Remove All

Removes all macro files from the list. This menu command is also available as a function button at the top of the window.

Reload

Registers the selected macro file. Typically, this is useful when you have edited a macro file. This menu command is also available as a function button at the top of the window.

Open File

Opens the selected macro file in the editor window.

Open Debugger Macros Window

Opens the **Debugger Macros** window.

Debugger Macros window

The **Debugger Macros** window is available from the **View>Macros** submenu during a debug session.

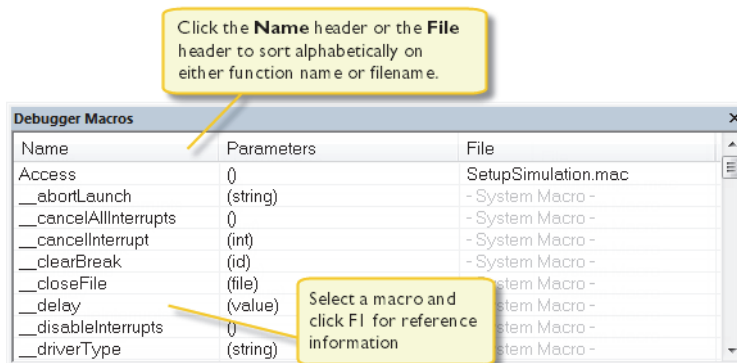

Use this window to list all registered debugger macro functions, either predefined system macros or your own. This window is useful when you edit your own macro functions and want an overview of all available macros that you can use.

- Click the column headers **Name** or **File** to sort alphabetically on either function name or filename.
- Double-clicking a macro defined in a file opens that file in the editor window.
- To open a macro in the **Macro Quicklaunch** window, drag it from the **Debugger Macros** window and drop it in the **Macro Quicklaunch** window.
- Select a macro and press F1 to get online help information for that macro.

Requirements

Can be used with all C-SPY debugger drivers and debug probes.

Display area

This area contains these columns:

Name

The name of the debugger macro.

Parameters

The parameters of the debugger macro.

File

For macros defined in a file, the name of the file is displayed. For predefined system macros, `-System Macro-` is displayed.

Context menu

This context menu is available:

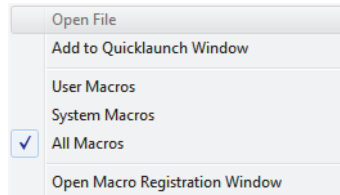

These commands are available:

Open File

Opens the selected debugger macro file in the editor window.

Add to Quicklaunch Window

Adds the selected macro to the **Macro Quicklaunch** window.

User Macros

Lists only the debugger macros that you have defined yourself.

System Macros

Lists only the predefined system macros.

All Macros

Lists all debugger macros, both predefined system macros and your own.

Open Macro Registration Window

Opens the **Macro Registration** window.

Macro Quicklaunch window

The **Macro Quicklaunch** window is available from the **View** menu.

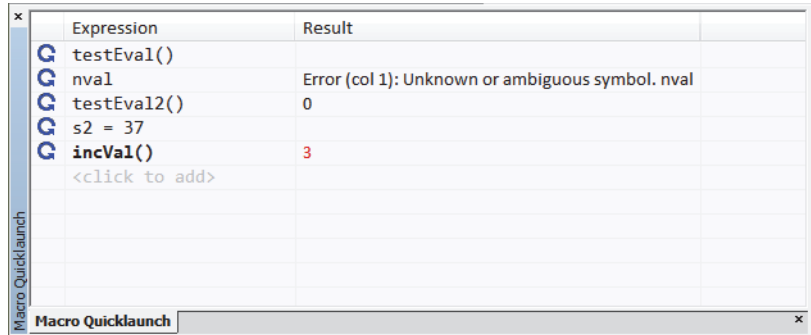

Use this window to evaluate expressions, typically C-SPY macros.

For some devices, there are predefined C-SPY macros available with device support, typically provided by the chip manufacturer. These macros are useful for performing certain device-specific tasks. The macros are available in the **Macro Quicklaunch** window and are easily identified by their green icon,

The **Macro Quicklaunch** window is similar to the **Quick Watch** window, but is primarily designed for evaluating C-SPY macros. The window gives you precise control over when to evaluate an expression.

See also *Executing C-SPY macros—an overview*, page 314.

To add an expression:

- I Choose one of these alternatives:
 - Drag the expression to the window
 - In the **Expression** column, type the expression you want to examine.

If the expression you add and want to evaluate is a C-SPY macro, the macro must first be registered, see *Registering C-SPY macros—an overview*, page 314.

To evaluate an expression:

- I  Double-click the **Recalculate** icon to calculate the value of that expression.

Requirements

Can be used with all C-SPY debugger drivers and debug probes.

Display area

This area contains these columns:



Recalculate icon

To evaluate the expression, double-click the icon. The latest evaluated expression appears in bold style.

Expression

One or several expressions that you want to evaluate. Click <click to add> to add an expression. If the return value has changed since last time, the value will be displayed in red.

Result

Shows the return value from the expression evaluation.

Context menu

This context menu is available:

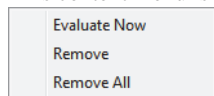

These commands are available:

Evaluate Now

Evaluates the selected expression.

Remove

Removes the selected expression.

Remove All

Removes all selected expressions.

The C-SPY command line utility—`cspybat`

- Using C-SPY in batch mode
- Summary of C-SPY command line options
- Reference information on C-SPY command line options

Using C-SPY in batch mode

You can execute C-SPY in batch mode if you use the command line utility `cspybat`, installed in the directory `common\bin`.

These topics are covered:

- Starting `cspybat`
- Output
- Invocation syntax

STARTING CSPYBAT

- 1 To start `cspybat` you must first create a batch file. An easy way to do that is to use one of the batch files that C-SPY automatically generates when you start C-SPY in the IDE.

C-SPY generates a batch file `projectname.buildconfiguration.cspy.bat` every time C-SPY is initialized. In addition, two more files are generated:

- `project.buildconfiguration.general.xcl`, which contains options specific to `cspybat`
- `project.buildconfiguration.driver.xcl`, which contains options specific to the C-SPY driver you are using

You can find the files in the directory `$PROJ_DIR$\settings`. The files contain the same settings as the IDE, and provide hints about additional options that you can use.

- 2 To start `cspybat`, you can use this command line:

```
project.cspybat.bat [debugfile]
```

Note that *debugfile* is optional. You can specify it if you want to use a different debug file than the one that is used in the *project.buildconfiguration.general.xml* file.

OUTPUT

When you run `cspybat`, these types of output can be produced:

- *Terminal output from cspybat itself*
All such terminal output is directed to `stderr`. Note that if you run `cspybat` from the command line without any arguments, the `cspybat` version number and all available options including brief descriptions are directed to `stdout` and displayed on your screen.
- *Terminal output from the application you are debugging*
All such terminal output is directed to `stdout`, provided that you have used the `--plugin` option. See *--plugin*, page 393.
- *Error return codes*
`cspybat` returns status information to the host operating system that can be tested in a batch file. For *successful*, the value `int 0` is returned, and for *unsuccessful* the value `int 1` is returned.

INVOCATION SYNTAX

The invocation syntax for `cspybat` is:

```
cspybat processor_DLL driver_DLL debug_file
        [cspybat_options] --backend driver_options
```

Note: In those cases where a filename is required—including the DLL files—you are recommended to give a full path to the filename.

Parameters

The parameters are:

Parameter	Description
<i>processor_DLL</i>	The processor-specific DLL file; available in <code>430\bin</code> .
<i>driver_DLL</i>	The C-SPY driver DLL file; available in <code>430\bin</code> .
<i>debug_file</i>	The object file that you want to debug (filename extension <code>d43</code>). See also <i>--debug_file</i> , page 382.

Table 41: *cspybat* parameters

Parameter	Description
<i>csybat_options</i>	The command line options that you want to pass to cspybat. Note that these options are optional. For information about each option, see <i>Reference information on C-SPY command line options</i> , page 378.
--backend	Marks the beginning of the parameters to the C-SPY driver; all options that follow will be sent to the driver. Note that this option is mandatory.
<i>driver_options</i>	The command line options that you want to pass to the C-SPY driver. Note that some of these options are mandatory and some are optional. For information about each option, see <i>Reference information on C-SPY command line options</i> , page 378.

Table 41: cspybat parameters (Continued)

Summary of C-SPY command line options

Reference information about:

- General cspybat options
- Options available for all C-SPY drivers
- Options available for the simulator driver
- Options available for the C-SPY FET Debugger driver

GENERAL CSPYBAT OPTIONS

--application_args	Passes command line arguments to the debugged application.
--attach_to_running_target	Makes the debugger attach to a running application at its current location, without resetting the target system.
--backend	Marks the beginning of the parameters to be sent to the C-SPY driver (mandatory).
--code_coverage_file	Enables the generation of code coverage information and places it in a specified file.
--cycles	Specifies the maximum number of cycles to run.
--debug_file	Specifies an alternative debug file.

<code>--downloadonly</code>	Downloads a code image without starting a debug session afterwards.
<code>-f</code>	Extends the command line.
<code>--leave_target_running</code>	Makes the debugger leave the application running on the target hardware after the debug session is closed.
<code>--macro</code>	Specifies a macro file to be used.
<code>--macro_param</code>	Assigns a value to a C-SPY macro parameter.
<code>--plugin</code>	Specifies a plugin file to be used.
<code>--silent</code>	Omits the sign-on message.
<code>--timeout</code>	Limits the maximum allowed execution time.

OPTIONS AVAILABLE FOR ALL C-SPY DRIVERS

<code>--core</code>	Specifies the core to be used.
<code>-d</code>	Specifies the C-SPY driver to be used.
<code>-p</code>	Specifies the device description file to be used.

OPTIONS AVAILABLE FOR THE SIMULATOR DRIVER

<code>--disable_interrupts</code>	Disables the interrupt simulation.
<code>--function_profiling</code>	Analyzes your source code to find where the most time is spent during execution.
<code>--mapu</code>	Activates memory access checking.
<code>--odd_word_check</code>	Stops the execution if an access to an odd address is found.

OPTIONS AVAILABLE FOR THE C-SPY FET DEBUGGER DRIVER

<code>--allow_access_to_BSL</code>	Enables erase/write access to BSL flash memory.
<code>--allow_locked_flash_access</code>	Enables erase/write access to locked flash memory.

<code>--connection</code>	Specifies the communication channel to be used.
<code>--derivative</code>	Specifies the device.
<code>--disable_memory_cache</code>	Disables the memory cache in the FET debugger.
<code>--eem</code>	Specifies the level of Enhanced Emulation Mode.
<code>--erase_exclude</code>	Excludes a memory segment from being erased.
<code>--erase_exclude_all</code>	Excludes the whole FRAM memory from being erased.
<code>--erase_ip_protected</code>	Erases main and Information flash memories, including the IP protected area before download.
<code>--erase_main</code>	Erases main flash memory before download.
<code>--erase_main_and_info</code>	Erases the main and Information flash memories before download.
<code>--erase_retain_file</code>	Retains unchanged memory during download.
<code>--erase_retain_target</code>	Retains unchanged memory during download.
<code>--hardware_multiplier</code>	Generates code for the hardware multiplier peripheral unit.
<code>--hwmult_type</code>	Specifies the type of hardware multiplier to be used.
<code>--jtag_speed</code>	Specifies the JTAG communication speed.
<code>--lptx</code>	Specifies the parallel port to be used.
<code>--mspdlogfile</code>	Logs the debug communication with <code>mcp430.dll</code> .
<code>--port</code>	Specifies the serial port to be used.
<code>--protocol</code>	Specifies the debug protocol to be used.
<code>--restore_fram_memory</code>	Restores a FRAM memory area after the usual memory erase and write.
<code>--retain_fram_memory</code>	Retains a FRAM memory area.
<code>--set_exit_breakpoint</code>	Sets a system breakpoint on <code>exit</code> .
<code>--set_getchar_breakpoint</code>	Sets a system breakpoint on <code>getchar</code> .
<code>--set_putchar_breakpoint</code>	Sets a system breakpoint on <code>putchar</code> .

<code>--settlingtime</code>	Specifies the delay after setting the voltage.
<code>--use_emulated_breakpoints</code>	Allows C-SPY to use emulated breakpoints.
<code>--use_virtual_breakpoints</code>	Allows C-SPY to use virtual breakpoints.
<code>--vccvoltage</code>	Specifies the voltage provided by the USB interface.
<code>--verify_all</code>	Verifies the download of your application.

Reference information on C-SPY command line options

This section gives detailed reference information about each `cspybat` option and each option available to the C-SPY drivers.

--allow_access_to_BSL

Syntax	<code>--allow_access_to_BSL</code>
For use with	The C-SPY FET Debugger driver.
Description	Use this option to enable erase/write access to BSL flash memory.
	 Project>Options>Debugger>FET Debugger>Download>Allow erase/write access to BSL flash memory

--allow_locked_flash_access

Syntax	<code>--allow_locked_flash_access</code>
For use with	The C-SPY FET Debugger driver.
Description	Use this option to enable erase/write access to locked flash memory.
	 Project>Options>Debugger>FET Debugger>Download>Allow erase/write access to locked flash memory

--application_args

Syntax	<code>--application_args="arg0 arg1 ..."</code>
Parameters	<i>arg</i> A command line argument.
For use with	cspybat
Description	Use this option to pass command line arguments to the debugged application. These variables must be defined in the application: <pre>/* __argc, the number of arguments in __argv. */ __no_init int __argc; /* __argv, an array of pointers to the arguments (strings); must be large enough to fit the number of arguments.*/ __no_init const char * __argv[MAX_ARGS]; /* __argvbuf, a storage area for __argv; must be large enough to hold all command line arguments. */ __no_init __root char __argvbuf[MAX_ARG_SIZE];</pre>
Example	<code>--application_args="--logfile log.txt --verbose"</code>



To set this option, use **Project>Options>Debugger>Extra Options**

--attach_to_running_target

Syntax	<code>--attach_to_running_target</code>
For use with	cspybat. Note: This option might not be supported by the combination of C-SPY driver and device that you are using. If you are using this option with an unsupported combination, C-SPY produces a message.
Description	Use this option to make the debugger attach to a running application at its current location, without resetting the target system. If you have defined any breakpoints in your project, the C-SPY driver will set them during attachment. If the C-SPY driver cannot set them without stopping the target system, the breakpoints will be disabled. The option also suppresses download and the Run to option.

**Project>Attach to Running Target****--backend**

Syntax	<code>--backend {<i>driver options</i>}</code>
Parameters	<i>driver options</i> Any option available to the C-SPY driver you are using.
For use with	<code>cspybat</code> (mandatory).
Description	Use this option to send options to the C-SPY driver. All options that follow <code>--backend</code> will be passed to the C-SPY driver, and will not be processed by <code>cspybat</code> itself.



This option is not available in the IDE.

--connection

Syntax	<code>--connection <i>Port</i></code>
Parameters	<i>Port</i> The communication channel to be used; choose between: <code>ti_usb</code> , <code>ti_lpt</code> , <code>jlink</code> , <code>olimex</code> , <code>olimex_parallel</code> , <code>elprotonic</code> , <code>softbaugh_lpt</code> , <code>softbaugh_usb</code> , and <code>softbaugh_usb_pro</code> .
For use with	The C-SPY FET Debugger driver.
Description	Use this option to specify the communication channel to be used between C-SPY and the target system.

**Project>Options>Debugger>FET Debugger>Setup>Connection****--core**

Syntax	<code>--core {<i>430X</i> <i>430Xv2</i>}</code>
Parameters	<i>430X</i> <i>430Xv2</i> The core you are using. This option reflects the corresponding compiler option.

For use with	All C-SPY drivers.
Description	Use this option to specify the core you are using.
See also	The <i>IAR C/C++ Compiler User Guide for MSP430</i> for information about the cores.



Project>Options>General Options>Target>Device

--code_coverage_file

Syntax	<code>--code_coverage_file file</code>
	Note that this option must be placed before the <code>--backend</code> option on the command line.
Parameters	<i>file</i> The name of the destination file for the code coverage information.
For use with	<code>cspybat</code>
Description	Use this option to enable the generation of a text-based report file for code coverage information. The code coverage information will be generated after the execution has completed and you can find it in the specified file. Because most embedded applications do not terminate, you might have to use this option in combination with <code>--timeout</code> or <code>--cycles</code> . Note that this option requires that the C-SPY driver you are using supports code coverage. If you try to use this option with a C-SPY driver that does not support code coverage, an error message will be directed to <code>stderr</code> .
See also	<i>Code coverage</i> , page 235, <i>--cycles</i> , page 381, <i>--timeout</i> , page 396.



To set this option, choose **View>Code Coverage**, right-click and choose **Save As** when the C-SPY debugger is running.

--cycles

Syntax	<code>--cycles cycles</code>
	Note that this option must be placed before the <code>--backend</code> option on the command line.
Parameters	<i>cycles</i> The number of cycles to run.

For use with	<code>cspybat</code>
Description	Use this option to specify the maximum number of cycles to run. If the target program executes longer than the number of cycles specified, the target program will be aborted. Using this option requires that the C-SPY driver you are using supports a cycle counter, and that it can be sampled while executing.



This option is not available in the IDE.

-d

Syntax	<code>-d {sim fet}</code>				
Parameters	<table> <tr> <td><code>sim</code></td> <td>Specifies the simulator driver.</td> </tr> <tr> <td><code>fet</code></td> <td>Specifies the FET debugger driver.</td> </tr> </table>	<code>sim</code>	Specifies the simulator driver.	<code>fet</code>	Specifies the FET debugger driver.
<code>sim</code>	Specifies the simulator driver.				
<code>fet</code>	Specifies the FET debugger driver.				
For use with	All C-SPY drivers.				
Description	Use this option to specify the C-SPY driver to be used.				



Project>Options>Debugger>Setup>Driver

--debug_file

Syntax	<code>--debug_file filename</code>		
Parameters	<table> <tr> <td><code>filename</code></td> <td>The name of the debug file to use.</td> </tr> </table>	<code>filename</code>	The name of the debug file to use.
<code>filename</code>	The name of the debug file to use.		
For use with	<code>cspybat</code>		
Description	Use this option to make <code>cspybat</code> use the specified debug file instead of the one used in the generated <code>cpsybat.bat</code> file. This option can be placed both before and after the <code>--backend</code> option on the command line.		



This option is not available in the IDE.

--derivative

Syntax	<code>--derivative <i>device</i></code>
Parameters	<i>device</i> Specifies the device to be used.
For use with	The C-SPY FET Debugger driver.
Description	Use this option to select the device for which you will build your application.



Project>Options>General Options>Target>Device

--disable_interrupts

Syntax	<code>--disable_interrupts</code>
For use with	The C-SPY Simulator driver.
Description	Use this option to disable the interrupt simulation.



To set this option, choose **Simulator>Interrupt Configuration** and deselect the **Enable interrupt simulation** command on the context menu.

--disable_memory_cache

Syntax	<code>--disable_memory_cache</code>
For use with	The C-SPY FET Debugger driver.
Description	Use this option to disable the memory cache in the FET debugger.



Project>Options>Debugger>FET Debugger>Setup>Disable memory cache

--downloadonly

Syntax	<code>--downloadonly</code>
	Note that this option must be placed before the <code>--backend</code> option on the command line.

For use with	cspybat
Description	Use this option to download the code image without starting a debug session afterwards.



Project>Download>Download active application

--eem

Syntax	--eem { <i>level</i> }
--------	------------------------

Parameters	
------------	--

<i>level</i>	Implementation level of Enhanced Emulation Module. Choose between:
	EMEX_LOW
	EMEX_MEDIUM
	EMEX_HIGH
	EMEX_EXTRA_SMALL_5XX
	EMEX_SMALL_5XX
	EMEX_MEDIUM_5XX
	EMEX_LARGE_5XX
	EMEX_NONE

For use with	The C-SPY FET Debugger driver.
--------------	--------------------------------

Description	Use this option to specify the implementation level of Enhanced Emulation Module for a MSP430 device. The default value is <code>EMEX_NONE</code> . The value of this option depends on the device you are using.
-------------	---



This option is automatically set when you are using the IDE.

--erase_exclude

Syntax	--erase_exclude <i>range</i>
--------	------------------------------

Parameters	<i>range</i> The memory range of the segment, in the form <i>startaddress:endaddress</i> .
For use with	The C-SPY FET Debugger driver, but not devices with FRAM memory.
Description	Use this option to exclude a memory segment from being erased. The segments that overlap with the specified area will not be erased.
Example	<code>--erase_exclude 0x2180:0x2220</code>



Project>Options>Debugger>Extra Options

--erase_exclude_all

Syntax	<code>--erase_exclude_all</code>
For use with	The C-SPY FET Debugger driver.
Description	Use this option to exclude the whole FRAM memory from being erased before downloading.



Project>Options>Debugger>Extra Options

--erase_ip_protected

Syntax	<code>--erase_ip_protected</code>
For use with	The C-SPY FET Debugger driver.
Description	Use this option to erase the main and Information flash memories, including the IP protected area before download.



Project>Options>Debugger>FET Debugger>Download>Erase main and Information memory inc. IP PROTECTED area

--erase_main

Syntax	<code>--erase_main</code>
--------	---------------------------

For use with	The C-SPY FET Debugger driver.
Description	Use this option to erase the main flash memory before download. The Information memory is not erased.



Project>Options>Debugger>FET Debugger>Download>Erase main memory

--erase_main_and_info

Syntax	<code>--erase_main_and_info</code>
For use with	The C-SPY FET Debugger driver.
Description	Use this option to erase both flash memories—main and Information memory—before download.



Project>Options>Debugger>FET Debugger>Download>Erase main and Information memory

--erase_retain_file

Syntax	<code>--erase_retain_file</code>
For use with	The C-SPY FET Debugger driver.
Description	Use this option to make C-SPY read the main and Information memories into a buffer. Only the flash segments that are needed are erased. If data that is to be written into a segment matches the data in the image that is cached on the host computer, the data in the image is left as is, and no download is performed. The new data effectively replaces the old data, and unchanged old data is retained.



Project>Options>Debugger>FET Debugger>Download>Retain unchanged memory>Compare with image cached on PC

--erase_retain_target

Syntax	<code>--erase_retain_target</code>
For use with	The C-SPY FET Debugger driver.

Description Use this option to make C-SPY read the main and Information memories into a buffer. Only the flash segments that are needed are erased. If data that is to be written into a segment matches the data on the target, the data on the target is left as is, and no download is performed. The new data effectively replaces the old data, and unchanged old data is retained.



Project>Options>Debugger>FET Debugger>Download>Retain unchanged memory>Compare with image on target

-f

Syntax `-f filename`

Parameters `filename`

A text file that contains the command line options (default filename extension `.xcl`).

For use with `cspybat`

Description Use this option to make `cspybat` read command line options from the specified file. In the command file, you format the items exactly as if they were on the command line itself, except that you may use multiple lines, because the newline character is treated like a space or tab character. Both C/C++ style comments are allowed in the file. Double quotes behave in the same way as in the Microsoft Windows command line environment. This option can be placed either before or after the `--backend` option on the command line.



To set this option, use **Project>Options>Debugger>Extra Options**.

--function_profiling

Syntax `--function_profiling filename`

Parameters `filename`

The name of the log file where the profiling data is saved.

For use with The C-SPY simulator driver.

Description Use this option to find the functions in your source code where the most time is spent during execution. The profiling information is saved to the specified file. For more information about function profiling, see *Profiling*, page 225.



C-SPY driver>Function Profiling

--hardware_multiplier

Syntax `--hardware_multiplier {16|32}`

Parameters

16	The size of the multiplicands in bits. Note that this parameter can only be used in combination with the <code>--hwmult_type</code> parameters 1 and 2.
32	The size of the multiplicands in bits. Note that this parameter can only be used in combination with the <code>--hwmult_type</code> parameters 4 and 8.

For use with The C-SPY FET Debugger driver.

Description Use this option to generate code for the MSP430 hardware multiplier peripheral unit. Use this option only when you have chosen a device with a hardware multiplier.

Note: This option requires that you also specify the `--hwmult_type` option.



To set related options, choose:

Project>Options>General Options>Target>Hardware multiplier

--hwmult_type

Syntax `--hwmult_type {1|2|4|8}`

Parameters

1	16 bits Note that this parameter can only be combined with the <code>--hardware_multiplier</code> parameter 16.
---	--

2	16 bits, the 2xx Family
	Note that this parameter can only be combined with the <code>--hardware_multiplier</code> parameter 16.
4	32 bits
	Note that this parameter can only be combined with the <code>--hardware_multiplier</code> parameter 32.
8	32 bits, the 5xx Families
	Note that this parameter can only be combined with the <code>--hardware_multiplier</code> parameter 32.

For use with The C-SPY FET Debugger driver.

Description Use this option to generate code for the MSP430 hardware multiplier peripheral unit. Use this option only when you have chosen a device with a hardware multiplier.

Note: This option requires that you also specify the `--hardware_multiplier` option.



To set related options, choose:

Project>Options>General Options>Target>Hardware multiplier

--jtag_speed

Syntax `--jtag_speed{fast|medium|slow}`

Parameters

<code>fast</code>	The fast communication speed.
<code>medium</code>	The medium communication speed.
<code>slow</code>	The slow communication speed.

For use with The C-SPY FET Debugger driver.

Description Use this option to set the JTAG communication speed.



Project>Options>Debugger>Fet Debugger>Setup>Jtag speed

--leave_target_running

Syntax	--leave_target_running
For use with	cspybat. The C-SPY FET Debugger driver.
Description	Use this option to make the debugger leave the application running on the target hardware after the debug session is closed.



Any existing breakpoints will not be automatically removed. You might want to consider disabling all breakpoints before using this option.



C-SPY driver>Leave Target Running

--lptx

Syntax	--lptx
For use with	The C-SPY FET Debugger driver.
Description	Use this option to specify which parallel port the FET Debugger is connected to. <i>x</i> can be 1, 2, or 3.



Project>Options>Debugger>FET Debugger>Setup>Parallel port

--macro

Syntax	--macro <i>filename</i> Note that this option must be placed before the --backend option on the command line.
Parameters	<i>filename</i> The C-SPY macro file to be used (filename extension <code>mac</code>).
For use with	cspybat

Description Use this option to specify a C-SPY macro file to be loaded before executing the target application. This option can be used more than once on the command line.

See also *Briefly about using C-SPY macros*, page 312.



Project>Options>Debugger>Setup>Setup macros>Use macro file

--macro_param

Syntax `--macro_param [param=value]`

Note that this option must be placed before the `--backend` option on the command line.

Parameters `param=value`
`param` is a parameter defined using the `__param` C-SPY macro construction.
`value` is a value.

For use with `cspybat`

Description Use this option to assign a value to a C-SPY macro parameter. This option can be used more than once on the command line.

See also *Macro parameters*, page 319.



To set this option, use **Project>Options>Debugger>Extra Options**

--mapu

Syntax `--mapu`

For use with The C-SPY simulator driver.

Description Specify this option to use the segment information in the debug file for memory access checking. During the execution, the simulator will then check for accesses to unspecified memory ranges. If any such access is found, the C function call stack and a message will be printed on `stderr` and the execution will stop.

See also *Monitoring memory and registers*, page 144.



To set related options, choose:

Simulator>Memory Access Setup

--mspdlogfile

Syntax	--mspdlogfile
For use with	The C-SPY FET Debugger driver.
Description	Use this option to log the debug communication with <code>mcp430.dll</code> during the current debug session. The logged information is written to the <code>mcpcom.log</code> file.



Project>Options>Debugger>Extra Options

--odd_word_check

Syntax	--odd_word_check
For use with	The C-SPY simulator driver.
Description	Use this option to make the simulator issue a warning if there is a word access to an odd address.



Project>Options>Debugger>Simulator>Setup>Check for word access on odd address

-p

Syntax	-p <i>filename</i>
Parameters	<i>filename</i> The device description file to be used.
For use with	All C-SPY drivers.
Description	Use this option to specify the device description file to be used.
See also	<i>Selecting a device description file</i> , page 44.



Project>Options>Debugger>Setup>Device description file

--plugin

Syntax	<code>--plugin filename</code>
	Note that this option must be placed before the <code>--backend</code> option on the command line.
Parameters	<i>filename</i> The plugin file to be used (filename extension <code>dll</code>).
For use with	<code>cspybat</code>
Description	<p>Certain C/C++ standard library functions, for example <code>printf</code>, can be supported by C-SPY—for example, the C-SPY Terminal I/O window—instead of by real hardware devices. To enable such support in <code>cspybat</code>, a dedicated plugin module called <code>430bat.dll</code> located in the <code>430\bin</code> directory must be used.</p> <p>Use this option to include this plugin during the debug session. This option can be used more than once on the command line.</p> <p>Note: You can use this option to also include other plugin modules, but in that case the module must be able to work with <code>cspybat</code> specifically. This means that the C-SPY plugin modules located in the <code>common\plugin</code> directory cannot normally be used with <code>cspybat</code>.</p>



Project>Options>Debugger>Plugins

--port

Syntax	<code>--port port</code>
Parameters	<i>port</i> The serial port to be used, can be <code>COMx</code> or <code>Automatic.x</code> is the number of the COM port.
For use with	The C-SPY FET Debugger driver.
Description	Use this option to specify which serial port the FET Debugger is connected to.



Project>Options>Debugger>FET Debugger>Setup>Connection

--protocol

Syntax	<code>--protocol {spy-bi-wire spy-bi-wire-jtag 4wire}</code>	
Parameters	<code>spy-bi-wire</code>	The Spy-Bi-Wire JTAG protocol.
	<code>spy-bi-wire-jtag</code>	4-wire JTAG protocol for devices that also support Spy-Bi-Wire.
	<code>4wire</code>	The ordinary 4-wire JTAG protocol.
For use with	The C-SPY FET Debugger driver.	
Description	Use this option to specify the debug protocol. Spy-Bi-Wire works for the parallel port FET module and the TI USB FET module.	



Project>Options>Debugger>FET Debugger>Setup>Debug protocol

--restore_fram_memory

Syntax	<code>--restore_fram_memory range</code>	
Parameters	<code>range</code>	The memory range of the FRAM memory area, in the form <i>startaddress:endaddress</i> .
For use with	The C-SPY FET Debugger driver, and only FRAM devices.	
Description	Use this option to restore a FRAM memory area after the usual memory erase and write.	
Example	<code>--restore_fram_area 0x2180:0x222</code>	



Project>Options>Debugger>Extra Options

--retain_fram_memory

Syntax	<code>--retain_fram_memory range</code>
--------	---

Parameters	<i>range</i>	The memory range of the FRAM memory area, in the form <i>startaddress:endaddress</i> .
For use with	The C-SPY FET Debugger driver, and only FRAM devices.	
Description	Use this option to retain a FRAM memory area. The memory area will not be written. This option requires that the download option Retain unchanged memory has been selected.	
Example	<code>--retain_fram_area 0x2180:0x222</code>	



Project>Options>Debugger>Extra Options

--set_exit_breakpoint

Syntax	<code>--set_exit_breakpoint</code>	
For use with	The C-SPY FET Debugger driver.	
Description	Use this option to set a system breakpoint for <code>exit</code> .	



Project>Options>Debugger>FET Debugger>Breakpoints>System breakpoints on>exit

--set_getchar_breakpoint

Syntax	<code>--set_getchar_breakpoint</code>	
For use with	The C-SPY FET Debugger driver.	
Description	Use this option to set a system breakpoint for <code>getchar</code> .	



Project>Options>Debugger>FET Debugger>Breakpoints>System breakpoints on>getchar

--set_putchar_breakpoint

Syntax	<code>--set_putchar_breakpoint</code>	
For use with	The C-SPY FET Debugger driver.	

Description

Use this option to set a system breakpoint for `putchar`.**Project>Options>Debugger>FET Debugger>Breakpoints>System breakpoints on>putchar**

--settlingtime

Syntax

`--settlingtime=milliseconds`

For use with

The C-SPY FET Debugger driver.

Description

Use this option to specify the delay between switching on the target VCC and starting the identification of the MSP430 device. Give the value in milliseconds in the range 0-9999 ms. This option can only be used with a USB connection.

**Project>Options>Debugger>FET Debugger>Setup>Target VCC>Settling time (in ms)**

--silent

Syntax

`--silent`Note that this option must be placed before the `--backend` option on the command line.

For use with

`cspybat`

Description

Use this option to omit the sign-on message.



This option is not available in the IDE.

--timeout

Syntax

`--timeout milliseconds`Note that this option must be placed before the `--backend` option on the command line.

Parameters

milliseconds

The number of milliseconds before the execution stops.

For use with

`cspybat`

Description

Use this option to limit the maximum allowed execution time.



This option is not available in the IDE.

--use_emulated_breakpoints

Syntax	<code>--use_emulated_breakpoints</code>
For use with	The C-SPY FET Debugger driver.
Description	Use this option to allow C-SPY to use emulated breakpoints.



Project>Options>Debugger>FET Debugger>Breakpoints>Use software breakpoints>Emulated breakpoints

--use_virtual_breakpoints

Syntax	<code>--use_virtual_breakpoints</code>
For use with	The C-SPY FET Debugger driver.
Description	Use this option to allow C-SPY to use virtual breakpoints.



Project>Options>Debugger>FET Debugger>Breakpoints>Use software breakpoints>Virtual breakpoints

--vccvoltage

Syntax	<code>--vccvoltage=<i>volts</i></code>
For use with	The C-SPY FET Debugger driver.
Description	Use this option to specify the voltage provided by the USB interface. Give the value in Volts with one decimal's precision in the range 1.0-4.0 V. This option can only be used with a USB connection.



Project>Options>Debugger>FET Debugger>Setup>Target VCC>Target VCC (in Volt)

--verify_all

Syntax	<code>--verify_all</code>
--------	---------------------------

For use with	The C-SPY FET Debugger driver.
Description	Use this option to verify that the downloaded code image can be read back from target memory with the correct contents.



Project>Options>Debugger>FET Debugger>Download>Verify download

Part 4. Additional reference information

This part of the *C-SPY® Debugging Guide for MSP430* includes these chapters:

- Debugger options
- Additional information on C-SPY drivers

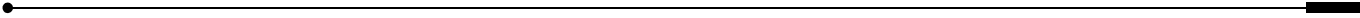
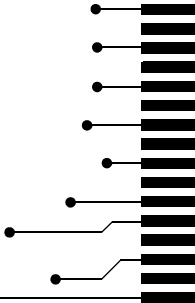



Debugger options

- Setting debugger options
- Reference information on general debugger options
- Reference information on the C-SPY simulator
- Reference information on C-SPY hardware debugger driver options

Setting debugger options

Before you start the C-SPY debugger you might need to set some options—both C-SPY generic options and options required for the target system (C-SPY driver-specific options).

To set debugger options in the IDE:

- 1 Choose **Project>Options** to display the **Options** dialog box.
- 2 Select **Debugger** in the **Category** list.

For more information about the generic options, see *Reference information on general debugger options*, page 402.

- 3 On the **Setup** page, make sure to select the appropriate C-SPY driver from the **Driver** drop-down list.
- 4 To set the driver-specific options, select the appropriate driver from the **Category** list. Depending on which C-SPY driver you are using, different options are available.

C-SPY driver	Available options pages
C-SPY FET Debugger driver	<i>Setup for FET Debugger</i> , page 407 <i>Download</i> , page 408 <i>Breakpoints</i> , page 410
C-SPY Simulator	<i>Setup options for the simulator</i> , page 406

Table 42: Options specific to the C-SPY drivers you are using

- 5 To restore all settings to the default factory settings, click the **Factory Settings** button.
- 6 When you have set all the required options, click **OK** in the **Options** dialog box.

Reference information on general debugger options

Reference information about:

- *Setup*, page 402
- *Images*, page 403
- *Extra Options*, page 404
- *Plugins*, page 405

Setup

The general **Setup** options select the C-SPY driver, the setup macro file, and device description file to use, and specify which default source code location to run to.

Driver

Selects the C-SPY driver for the target system you have.

Run to

Specifies the location C-SPY runs to when the debugger starts after a reset. By default, C-SPY runs to the `main` function.

To override the default location, specify the name of a different location you want C-SPY to run to. You can specify assembler labels or whatever can be evaluated as such, for example function names.

If the option is deselected, the program counter will contain the regular hardware reset address at each reset.

See also *Executing from reset*, page 44.

Setup macros

Registers the contents of a setup macro file in the C-SPY startup sequence. Select **Use macro file** and specify the path and name of the setup file, for example `SetupSimple.mac`. If no extension is specified, the extension `mac` is assumed. A browse button is available for your convenience.

Device description file

A default device description file is selected automatically based on your project settings. To override the default file, select **Override default** and specify an alternative file. A browse button is available.

For information about the device description file, see *Modifying a device description file*, page 48.

Device description files for each MSP430 device are provided in the directory `430\config` and have the filename extension `ddf`.

Images

The **Images** options control the use of additional debug files to be downloaded.

The screenshot shows a dialog box titled "Images" with three sections for configuring additional debug files to be downloaded. Each section includes a "Download extra image" checkbox, a "Path" text box with a browse button (...), an "Offset" text box, and a "Debug info only" checkbox. The first section has its checkbox checked, while the other two are unchecked.

Download extra Images

Controls the use of additional debug files to be downloaded:

Path

Specify the debug file to be downloaded. A browse button is available for your convenience.

Offset

Specify an integer that determines the destination address for the downloaded debug file.

Debug info only

Makes the debugger download only debug information, and not the complete debug file.

If you want to download more than three debug images, use the related C-SPY macro, see `__loadImage`, page 335.

For more information, see *Loading multiple debug images*, page 47.

Extra Options

The **Extra Options** page provides you with a command line interface to C-SPY.

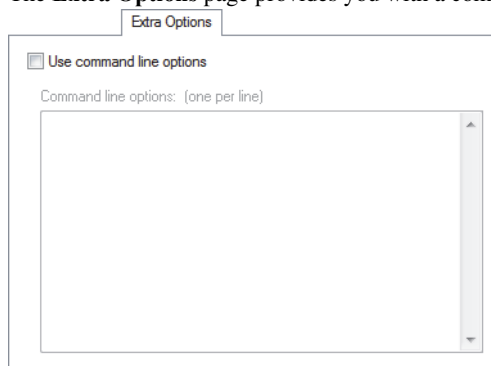

Use command line options

Specify command line arguments that are not supported by the IDE to be passed to C-SPY.

Note that it is possible to use the `/args` option to pass command line arguments to the debugged application.

Syntax: `/args arg0 arg1 ...`

Multiple lines with `/args` are allowed, for example:

```
/args --logfile log.txt
```

```
/args --verbose
```

If you use `/args`, these variables must be defined in your application:

```
/* __argc, the number of arguments in __argv. */
__no_init int __argc;

/* __argv, an array of pointers to strings that holds the
arguments; must be large enough to fit the number of
parameters.*/
__no_init const char * __argv[MAX_ARGS];

/* __argvbuf, a storage area for __argv; must be large enough to
hold all command line parameters. */
__no_init __root char __argvbuf[MAX_ARG_SIZE];
```

Plugins

The **Plugins** options select the C-SPY plugin modules to be loaded and made available during debug sessions.

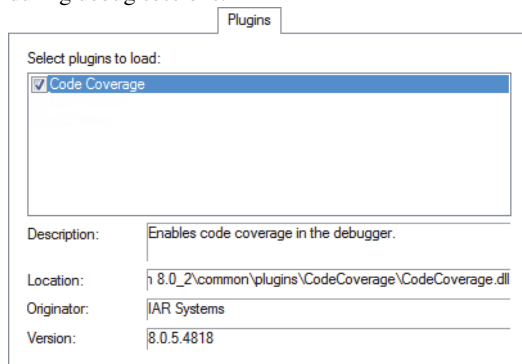

Select plugins to load

Selects the plugin modules to be loaded and made available during debug sessions. The list contains the plugin modules delivered with the product installation.

Description

Describes the plugin module.

Location

Informs about the location of the plugin module.

Generic plugin modules are stored in the `common\plugins` directory. Target-specific plugin modules are stored in the `430\plugins` directory.

Originator

Informs about the originator of the plugin module, which can be modules provided by IAR Systems or by third-party vendors.

Version

Informs about the version number.

Reference information on the C-SPY simulator

Reference information about:

- Setup options for the simulator

This section gives reference information on the C-SPY simulator options.

Setup options for the simulator

The simulator **Setup** options control the C-SPY simulator.

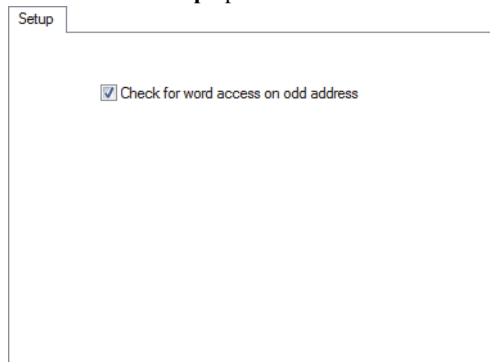

Check for word access on odd address

Makes the simulator issue a warning if there is a word access to an odd address.

Reference information on C-SPY hardware debugger driver options

Reference information about:

- *Setup for FET Debugger*, page 407
- *Download*, page 408
- *Breakpoints*, page 410

Setup for FET Debugger

The FET Debugger **Setup** options control the C-SPY FET Debugger driver.

Connection

Controls the communication between C-SPY and the target device.

The C-SPY FET Debugger can communicate with the target device via a number of different emulators. Select the emulator you are using.

If your emulator is connected to the host computer via a parallel port, you must also specify which parallel port to use: Parallel port 1, Parallel port 2, or Parallel port 3. If your emulator is connected to the host computer via a USB port, the debugger will automatically connect to the correct port.

Some emulator drivers support multiple emulators connected to the same host computer. Each emulator requires its own instance of IAR Embedded Workbench and each instance must identify its emulator. To identify an emulator, click the browse button to display a list of all detected emulators. To identify a connection, click the port in the list and the Mode LED on the attached emulator will light up.

Debug protocol

Determines the debug interface to use:

Automatic selection

Selects the debug interface automatically. (If **Connection** is set to `Automatic`, C-SPY correctly determines which interface to use.)

Manual selection

Spy-Bi-Wire to select the 2-wire JTAG (Spy-Bi-Wire) interface. Works with emulators from Elprotronic, Olimex, and Texas Instruments that connect via USB.

Disable memory cache

Disables the memory cache in the FET debugger.

Jtag speed

Sets the JTAG communication speed. Choose between **Fast**, **Medium**, and **Slow**.

Target VCC

Specify the voltage provided by the USB interface:

Override default

Overrides the default voltage. To see what the default voltage is, see *Device Information window*, page 56.

Target VCC

Specify the voltage with one decimal's precision in the range 1.0–4.0 V. This option can only be used with a USB connection.

Settling time

Specify a delay that will be used between switching on the target VCC and starting the identification of the MSP430 device.

Enable ULP/LPMx.5 debug

Enables debugging of applications that use the LPMx5 low-power mode.

Download

By default, C-SPY downloads the application to RAM or flash when a debug session starts. The **Download** options let you modify the behavior of the download.

The screenshot shows a dialog box titled "Download" with the following options:

- Verify download
- Allow erase/write access to locked flash memory
- Allow erase/write access to BSL flash memory
- External code download

Flash erase options:

- Erase main memory
- Erase main and Information memory
- Retain unchanged memory
 - Compare with image on target
 - Compare with image cached on PC
- Erase main and Information memory inc. IP PROTECTED area

JTAG password: lock device permanently

Verify download

Verifies that the downloaded code image can be read back from target memory with the correct contents.

Allow erase/write access to locked flash memory

Enables erase/write access to Info Segment A. This option can only be used with devices that have the Info Segment A memory.

Allow erase/write access to BSL flash memory

Enables erase/write access to BSL flash memory. This option can only be used with MSP430F5xx devices that have BSL flash memory.

External code download

Saves user code to external SPI memory.

Erase main memory

Erases only the main flash memory before download. The Information memory is not erased.

Erase main and Information memory

Erases both flash memories—main and Information memory—before download.

Retain unchanged memory

Reads the main and Information memories into a buffer. Only the flash segments that are needed are erased.

Compare with image on target

Compares the data that is to be written into a segment with the image on the target. If the data matches the image, the data on the target is left as is, and nothing is downloaded. The new data effectively replaces the old data, and unchanged old data is retained.

Compare with image cached on PC

Compares the data that is to be written into a segment with the image that is cached on the host computer.

Erase main and Information memory inc. IP PROTECTED area

Erases the main and Information flash memories, including the IP protected area before download.

Retain TLV data

Retains the TLV data for MSP430 i20xx devices.

JTAG password

If a JTAG device is password-protected, enter the needed password here.

Note: For MSP430F5xx/6xx devices, you can set a custom password. To enable this functionality in the IDE, add the `lockjtag` tag in the menu file that corresponds to your device, and set its value to 1. The menu files are located in the directory:

```
C:\Program Files\IAR Systems\Embedded Workbench 8.n\430\config\devices
```

Like this:

```
<lockjtag>1</lockjtag>
```

In addition to setting the `lockjtag` value to 1 in the menu file, you must select the **Lock device permanently** option to enable this functionality.

Set the custom password on the page **Project>Options>Debugger>FET Debugger>Download**.

Lock device permanently

Select this option to make it possible to use a custom JTAG password.

Breakpoints

The **Breakpoints** options control the use of breakpoints.

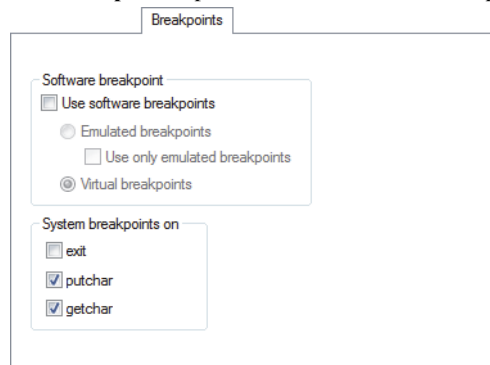

Use software breakpoints

Allows C-SPY to use software breakpoints when all available hardware breakpoints have been used. Choose between:

Emulated breakpoints

Makes C-SPY use emulated breakpoints: the instruction where the breakpoint is set will be replaced by a special instruction that the debugger recognizes.

Use only emulated breakpoints

C-SPY will use only emulated breakpoints.

Virtual breakpoints

Makes C-SPY use virtual breakpoints.

For information, see *Breakpoints in the C-SPY FET debugger driver*, page 111.

System breakpoints on

Controls the use of system breakpoints in the CLIB runtime environment. If the C-SPY **Terminal I/O** window is not required or if you do not need a breakpoint on the `exit` label, you can save hardware breakpoints by not reserving system breakpoints. Select or deselect the options **exit**, **putchar**, and **getchar** respectively, if you want, or do not want, C-SPY to use system breakpoints for these. For more information, see *Breakpoint consumers*, page 112.

In the DLIB runtime environment, C-SPY will always set a system breakpoint on the `__DebugBreak` label. You cannot disable this behavior.

Additional information on C-SPY drivers

This chapter describes the additional menus and features provided by the C-SPY® drivers. You will also find some useful hints about resolving problems.

Reference information on C-SPY driver menus

This section gives reference information on the menus specific to the C-SPY drivers. More specifically, this means:

- *C-SPY driver*, page 413
- *Simulator menu*, page 414
- *Emulator menu*, page 416

C-SPY driver

Before you start the C-SPY debugger, you must first specify a C-SPY driver in the **Options** dialog box, using the option **Debugger>Setup>Driver**.

When you start a debug session, a menu specific to that C-SPY driver will appear on the menu bar, with commands specific to the driver.

When we in this guide write “choose *C-SPY driver*>” followed by a menu command, *C-SPY driver* refers to the menu. If the feature is supported by the driver, the command will be on the menu.

Simulator menu

When you use the simulator driver, the **Simulator** menu is added to the menu bar.

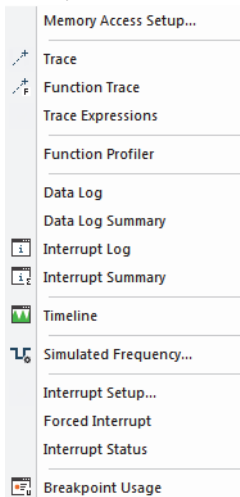

Menu commands

These commands are available on the menu:

Memory Access Setup

Displays a dialog box to simulate memory access checking by specifying memory areas with different access types, see *Memory Access Setup dialog box*, page 173.



Trace

Opens a window which displays the collected trace data, see *Trace window*, page 184.



Function Trace

Opens a window which displays the trace data for function calls and function returns, see *Function Trace window*, page 188.

Trace Expressions

Opens a window where you can specify specific variables and expressions for which you want to collect trace data, see *Trace Expressions window*, page 191.

Function Profiler

Opens a window which shows timing information for the functions, see *Function Profiler window*, page 230.

Data Log

Opens a window which logs accesses to up to four different memory locations or areas, see *Data Log window*, page 202.

Data Log Summary

Opens a window which displays a summary of data accesses to specific memory location or areas, see *Data Log Summary window*, page 205.

**Interrupt Log**

Opens a window which displays the status of all defined interrupts, see *Interrupt Log window*, page 281.

**Interrupt Log Summary**

Opens a window which displays a summary of the status of all defined interrupts, see *Interrupt Log Summary window*, page 284.

**Timeline**

Opens a window which gives a graphical view of various kinds of information on a timeline, see *Reference information on application timeline*, page 201.

**Simulated Frequency**

Opens the **Simulated Frequency** dialog box where you can specify the simulator frequency used when the simulator displays time information, for example in the log windows. Note that this does not affect the speed of the simulator. For more information, see *Simulated Frequency dialog box*, page 419.

Interrupt Setup

Displays a dialog box where you can configure C-SPY interrupt simulation, see *Interrupt Setup dialog box*, page 275.

Forced Interrupts

Opens a window from where you can instantly trigger an interrupt, see *Forced Interrupt window*, page 278.

Interrupt Status

Opens a window from where you can instantly trigger an interrupt, see *Interrupt Status window*, page 279.

**Breakpoint Usage**

Displays a window which lists all active breakpoints, see *Breakpoint Usage window*, page 121.

Emulator menu

When you are using the C-SPY FET Debugger driver, the **Emulator** menu is added to the menu bar.



These commands are available on the menu:

Menu commands

These commands are available on the menu:

Power Log Setup

Opens a window, see *Power Log Setup window*, page 252.

Power Log

Opens a window, see *Power Log window*, page 254.

State Log

Opens a window, see *State Log window*, page 259.

State Log Summary

Opens a window, see *State Log Summary window*, page 261.

Timeline

Opens a window, see *Reference information on application timeline*, page 201.

Data Sample Setup

Opens a window, see *Data Sample Setup window*, page 209.

Data Sample

Opens a window, see *Data Sample window*, page 208.

Sampled Graphs

Opens a window, see *Sampled Graphs window*, page 211.

Function Profiler

Opens a window which shoes timing information for the functions, see *Function Profiler window*, page 230.

Release JTAG on Go

Sets the JTAG drivers in tri-state so that the device is released from JTAG control—TEST pin is set to GND—when **Go** is activated.

**Leave Target Running**

Leaves the application running on the target hardware after the debug session is closed.



Any existing breakpoints will not be automatically removed. You might want to consider disabling all breakpoints before using this menu command.

If this menu command is not available, it is not supported by the C-SPY driver you are using.

**GIE on/off**

Clears the General Interrupt Enable bit (GIE) in the Processor Status register.

**Force Single Stepping**

Forces single step debugging.

**Force hardware RST/NMI**

Forces an RST/NMI clear reset when the **Reset** button is pressed.

Resynchronize JTAG

Regains control of the device.

It is not possible to resynchronize JTAG while the device is operating.

Init New Device

Initializes the device according to the settings in the **Projects>Options>FET Debugger** category. The current program file is downloaded to the device memory, and the device is then reset. This command can be used to program multiple devices with the same program from within the same C-SPY session.

It is not possible to choose **Init New Device** while the device is operating, thus the command will be dimmed.



State Storage Control

Opens the **State Storage Control** window, which lets you define the use of the state storage module, see *State Storage Control window*, page 301.



State Storage Window

Opens the **State Storage** window which contains state storage information according to your definitions, see *State Storage window*, page 303.



Sequencer Control

Opens the **Sequencer Control** window, which lets you define a state machine, see *Sequencer Control window*, page 309.

Advanced Cycle Counter

Opens a window, see *Advanced Cycle Counter Control window*, page 295.



Advanced>Clock Control

Lets you control the clocks on the device. Depending on the hardware support, either the **General Clock Control** dialog box or the **Extended Clock Control** dialog box is displayed. See *General Clock Control dialog box*, page 420 and *Extended Clock Control dialog box*, page 421, respectively.

Advanced>Emulation Mode

Specifies the device to be emulated. The device must be reset (or reinitialized by using the menu command **Init New Device**) following a change to the emulation mode.

Advanced>Memory Dump

Displays the **Memory Dump** dialog box, which lets you write device memory contents to a file, see *Memory Dump dialog box*, page 176.



Advanced>Breakpoint Combiner

Displays the **Breakpoint combiner** dialog box, which lets you combine two already defined breakpoints, see *Breakpoint combiner dialog box*, page 137.

User code erase (unlocks device)

Overrides and clears FRAM memory protection and erases the Information and main memories. (Only available for FR2xx and FR4xx devices.)

Secure - Blow JTAG Fuse

Blows the fuse on the target device. After the fuse is blown, no communication with the device is possible. Only available if you are using a USB-connected debug probe.

Breakpoint Usage

Opens a window which lists all active breakpoints, see *Breakpoint Usage window*, page 121.

Device information

Opens the **Device Information** window with information about the device used for debugging, see *Device Information window*, page 56.

Connected device

The name of the device used for debugging.

Note: Not all **Emulator>Advanced** submenu commands are available on all MSP430 devices.

Reference information on the C-SPY simulator

This section gives additional reference information the C-SPY simulator, reference information not provided elsewhere in this documentation.

Reference information about:

- *Simulated Frequency dialog box*, page 419

Simulated Frequency dialog box

The **Simulated Frequency** dialog box is available from the C-SPY driver menu.

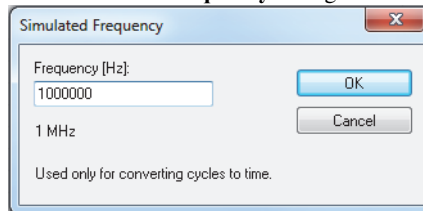

Use this dialog box to specify the simulator frequency used when the simulator displays time information.

Requirements

The C-SPY simulator.

Frequency

Specify the frequency in Hz.

Reference information on the C-SPY FET Debugger driver

This section gives additional reference information on the C-SPY hardware debugger drivers, reference information not provided elsewhere in this documentation.

More specifically, this means:

- *General Clock Control dialog box*, page 420
- *Extended Clock Control dialog box*, page 421

General Clock Control dialog box

The **General Clock Control** dialog box is available from the **Emulator** menu.

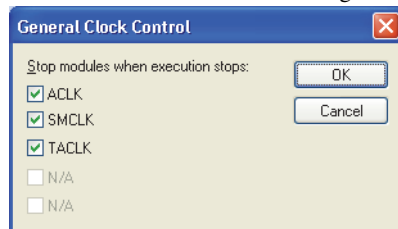

Use this dialog box to control the clocks of the device.

Select the clock modules you want to stop when the execution stops. The other clocks will keep running.

Which clock modules that are displayed depends on the available clocks on the connected device.

Requirements

The C-SPY FET Debugger driver.

Extended Clock Control dialog box

The **Extended Clock Control** dialog box is available from the **Emulator** menu.

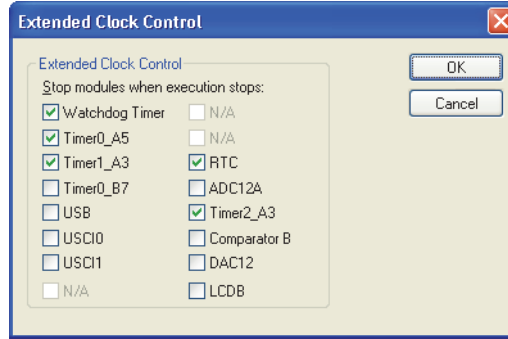

Use this dialog box for module level control over the clocks of the device.

Select the clock modules you want to stop when the execution stops. The other clocks will keep running.

Which clock modules that are displayed depends on the available clocks on the connected device.

Requirements

The C-SPY FET Debugger driver.

Resolving problems

These topics are covered:

- The device port pins do not work
- Write failure during load
- No contact with the target hardware

Debugging using the C-SPY hardware debugger systems requires interaction between many systems, independent from each other. For this reason, setting up this debug system can be a complex task. If something goes wrong, it might be difficult to locate the cause of the problem.

This section includes suggestions for resolving the most common problems that can occur when debugging with the C-SPY hardware debugger systems.

For problems concerning the operation of the evaluation board, refer to the documentation supplied with it, or contact your hardware distributor.

To troubleshoot the Flash Emulation Tool, see appendix A in the document *IAR Embedded Workbench Version 3+ for MSP430 User's Guide* at the Texas Instruments web site, www.ti.com. The document has the literature number *SLAU138AN*.

THE DEVICE PORT PINS DO NOT WORK

On some MSP430 devices, the device port pins are shared with the JTAG pins that C-SPY uses to debug the device. Normally, C-SPY maintains the pins in JTAG mode so that the device can be debugged. During this time the port functionality of the shared pins is not available.

To release the JTAG pins:

Choose **Emulator>Release JTAG on Go** to set the JTAG drivers to tri-state and release the device from JTAG control (the TEST pin is set to GND) when **Go** is activated. Any active on-chip breakpoints are retained and the shared JTAG port pins revert to their port functions.

Note: Be aware of the following:

- The JTAG pins will only be released if there are N or fewer active breakpoints.
- When you measure the electrical current of the device, the JTAG control signals must be released, otherwise the device will be powered by the signals on the JTAG pins and the measurements will be incorrect.
- If you release the JTAG pins, C-SPY has no access to the device and cannot determine if an active breakpoint has been triggered. C-SPY must be manually told to stop the device, at which time the state of the device will be determined (that is, has a breakpoint been reached?).

WRITE FAILURE DURING LOAD

There are several possible reasons for write failure during load. The most common is that your application has been incorrectly linked:

- Check the contents of your linker configuration file and make sure that your application has not been linked to the wrong address
- Check that you are using the correct linker configuration file.



To choose a device:

- 1 Choose **Project>Options**.
- 2 Select the **General Options** category.
- 3 Click the **Target** tab.
- 4 Choose the appropriate device from the **Device** drop-down list.

To override the default linker configuration file:

- 1** Choose **Project>Options**.
- 2** Select the **Linker** category.
- 3** Click the **Config** tab.
- 4** Select the **Override default** option, and choose the appropriate linker configuration file in the **Linker configuration file** area. A browse button is available.

NO CONTACT WITH THE TARGET HARDWARE

There are several possible reasons for C-SPY to fail to establish contact with the target hardware. Do this:

- Check the communication devices on your host computer
- Verify that the cable is properly plugged in and not damaged or of the wrong type
- Make sure that the evaluation board is supplied with sufficient power
- Check that the correct options for communication have been specified in the IAR Embedded Workbench IDE.

Examine the linker configuration file to make sure that the application has not been linked to the wrong address.

A

Abort (Report Assert option) 78
 __abortLaunch (C-SPY system macro) 328
 absolute location, specifying for a breakpoint 137
 Access type (Advanced Trigger breakpoints option) 135
 Access type (Edit Memory Access option) 175
 Access (Conditional breakpoints option) 132
 Access (Edit SFR option) 172
 Action (Advanced Trigger breakpoints option) 135
 Action (Conditional breakpoints option) 133
 Action (Sequencer option) 310
 Address Range (Find in Trace option) 194
 Address (Edit SFR option) 172
 Advanced Cycle Counter Control window 295
 Advanced Trigger breakpoints dialog box 134
 advanced trigger breakpoints, overview 109
 Advanced (Sequencer option) 310
 Advanced>Breakpoint Combiner (Emulator menu) 418
 Advanced>Clock Control (Emulator menu) 418
 Advanced>Emulation Mode (Emulator menu) 418
 Advanced>Memory Dump (Emulator menu) 418
 Allow erase/write access to locked flash memory (C-SPY FET Debugger option) 409
 Allow erase/write access to BSL flash memory (C-SPY FET Debugger option) 409
 --allow_access_to_BSL (C-SPY command line option) . . 378
 --allow_locked_flash_access (C-SPY command line option) 378
 Ambiguous symbol (Resolve Symbol Ambiguity option). 104
 application flow, monitoring 299
 Applications (Advanced Cycle Counter option) 295
 --application_args (C-SPY command line option) 379
 application, built outside the IDE 46
 assembler labels, viewing 86
 assembler source code, fine-tuning 225
 assembler symbols, in C-SPY expressions 83
 assembler variables, viewing 86
 assumptions, programming experience 23

Auto Scroll (Timeline window context menu) . 216, 220, 288
 Auto window 87
 Autostep settings dialog box 78

B

--attach_to_running_target (C-SPY command line option) 379
 --backend (C-SPY command line option) 380
 backtrace information, viewing in Call Stack window . . . 71
 batch mode, using C-SPY in 373
 Big Endian (Memory window context menu) 152
 blocks, in C-SPY macros 321
 bold style, in this guide 28
 Break At (Advanced Trigger breakpoints option) 134
 Break At (Conditional breakpoints option) 131
 Breakpoint combiner dialog box 137
 breakpoint condition, example 117–118
 breakpoint dialog box
 Code 122
 Data 125
 Data Log 127
 Immediate 128
 Log 123
 Trace Start Trigger 189
 Trace Stop Trigger 190
 Breakpoint Usage window 121
 Breakpoint Usage (Emulator menu) 419
 breakpoints
 advanced trigger 134
 briefly about 107
 code, example 348
 conditional 131
 using 300
 connecting a C-SPY macro 316
 consumers of 112
 data 125
 data log 127
 description of 107
 disabling used by Stack window 113

emulated, configuring	411
icons for in the IDE	110
in Memory window	115
listing all	121
range	129
reasons for using	107
setting	
in memory window	115
using system macros	116
using the dialog box	114
toggling	114
types of	108
useful tips	117
virtual, configuring	411
Breakpoints dialog box	
Advanced Trigger	134
Conditional	131
Range	129
Breakpoints window	119
Breakpoints (FET debugger options)	410
Browse (Trace toolbar)	185
byte order, setting in Memory window	151

C

C function information, in C-SPY	63
C symbols, in C-SPY expressions	83
C variables, in C-SPY expressions	82
call chain, displaying in C-SPY	63
Call Stack graph (Timeline window)	215
Call stack information	63
Call Stack window	71
for backtrace information	63
Call Stack (Timeline window context menu)	217
__cancelAllInterrupts (C-SPY system macro)	328
__cancelInterrupt (C-SPY system macro)	329
Check for word access on odd address (C-SPY simulator option)	406

Clear Group (Registers User Groups Setup window context menu)	167
Clear trace data (Trace toolbar)	185
Clear (Advanced Cycle Counter option)	297
__clearBreak (C-SPY system macro)	329
CLIB	
consuming breakpoints	112
library reference information for	26
naming convention	29
clock frequency, simulated	419
__closeFile (C-SPY system macro)	329
code breakpoints	
overview	108
toggling	114
code coverage, using	236
Code Coverage window	237
--code_coverage_file (C-SPY command line option)	381
code, covering execution of	237
command line options	378
typographic convention	28
command prompt icon, in this guide	28
computer style, typographic convention	27
Condition (Conditional breakpoints option)	133
conditional breakpoints	
overview	110
triggering state storage	300
Conditional breakpoints dialog box	131
conditional statements, in C-SPY macros	320
--connection (C-SPY command line option)	380
Connection (C-SPY FET Debugger option)	407
context menu, in windows	85
conventions, used in this guide	27
Copy Window Contents (Disassembly window context menu)	70
copyright notice	2
cores, inspecting state of	79
Cores window	79
CPU cycles, counting	292, 294
cspybat	373
reading options from file (-f)	387

- current position, in C-SPY Disassembly window 67
 - Current state (Sequencer option) 310
 - cursor, in C-SPY Disassembly window 67
 - Cycle counter values (Advanced Cycle Counter option) 296
 - cycles (C-SPY command line option) 381
 - C-SPY
 - batch mode, using in 373
 - debugger systems, overview of 37
 - environment overview 33
 - plugin modules, loading 45
 - scripting. *See* macros
 - setting up 43–44
 - starting the debugger 45
 - C-SPY drivers
 - differences between drivers 39
 - overview 39
 - specifying 402
 - types of 38
 - C-SPY expressions 82
 - evaluating, using Macro Quicklaunch window 370
 - evaluating, using Quick Watch window 99
 - in C-SPY macros 320
 - Tooltip watch, using 81
 - Watch window, using 81
 - C-SPY hardware debugger driver
 - extending functionality of 50
 - C-SPY macros
 - blocks 321
 - conditional statements 320
 - C-SPY expressions 320
 - examples 313
 - checking status of register 315
 - creating a log macro 316
 - executing 313
 - connecting to a breakpoint 316
 - using Quick Watch 315
 - using setup macro and setup file 315
 - functions 84, 318
 - keywords 318–319, 321
 - loop statements 321
 - macro statements 320
 - parameters 319
 - setup macro file 312
 - executing 315
 - setup macro functions 312
 - summary 323
 - system macros, summary of 325
 - using 311
 - variables 84, 318
 - C-SPY options
 - Breakpoints 410
 - Download 408
 - Extra Options 404
 - Images 403
 - Plugins 405
 - Setup 402
 - Setup (FET) 407
 - C-SPYLink 39
 - C-STAT for static analysis, documentation for 26
 - C++ terminology 27
- ## D
- d (C-SPY command line option) 382
 - data breakpoints, overview 109
 - Data Coverage (Memory window context menu) 152
 - data coverage, in Memory window 150
 - data log breakpoints, overview 109
 - Data Log graph (Timeline window) 218
 - Data Log Summary window 205
 - Data Log Summary (Simulator menu) 415
 - Data Log window 202
 - Data Log (Simulator menu) 415
 - Data Log (Timeline window context menu) 220
 - Data Sample Setup window 209
 - Data Sample window 208
 - Data Sample (Sampled Graphs window context menu) 213
 - ddf (filename extension), selecting a file 44

Debug Log window	75
Debug menu (C-SPY main window)	51
Debug protocol (C-SPY FET Debugger option)	407
Debug (Report Assert option)	78
--debug_file (cspybat option)	382
debugger concepts, definitions of	36
debugger drivers	
FET Debugger	40
simulator	40
debugger drivers. <i>See</i> C-SPY drivers	
Debugger Macros window	368
debugger system overview	37
debugging projects	
externally built applications	46
loading multiple images	47
debugging, RTOS awareness	35
__delay (C-SPY system macro)	330
Delay (Autostep Settings option)	78
Delete/revert All Custom SFRs (SFR Setup window context menu)	170
--derivative (C-SPY command line option)	383
Description (Edit Interrupt option)	277
description (interrupt property)	277
Device description file (debugger option)	403
device description files	44
definition of	48
memory zones	143
modifying	48
register zone	143
specifying interrupts	340
Device Information window	56
Device information (Emulator menu)	419
Device Support Module	50
Disable memory cache (C-SPY FET Debugger option)	408
__disableInterrupts (C-SPY system macro)	330
--disable_interrupts (C-SPY command line option)	383
--disable_memory_cache (C-SPY command line option)	383
Disassembly window	65
context menu	68
disclaimer	2

DLIB	
consuming breakpoints	112
naming convention	29
DMA load, measuring	292
do (macro statement)	321
document conventions	27
documentation	
overview of guides	25
overview of this guide	24
this guide	23
Download (FET debugger options)	408
--download_only (C-SPY command line option)	383
Driver (debugger option)	402
__driverType (C-SPY system macro)	330
E	
Edit Expressions (Trace toolbar)	185
Edit Interrupt dialog box	277
Edit Memory Access dialog box	175
Edit Memory Range dialog box	171
Edit Settings (Trace toolbar)	185
edition, of this guide	2
--eem (C-SPY command line option)	384
emulated breakpoints, configuring	411
Emulator menu (reference information)	416
Enable interrupt simulation (Interrupt Setup option)	275
Enable Log File (Log File option)	77
Enable ULP/LPMx.5 debug (C-SPY FET Debugger option)	408
Enable (Sampled Graphs window context menu)	213
Enable (Timeline window context menu)	217
__enableInterrupts (C-SPY system macro)	331
Enable/Disable Breakpoint (Disassembly window context menu)	70
Enable/Disable (Trace toolbar)	185
End address (Memory Save option)	153
endianness. <i>See</i> byte order	
Enter Location dialog box	136

Erase main and Information memory inc.
 IP PROTECTED area (C-SPY FET Debugger option) . . . 409
 Erase main and Information memory (C-SPY FET Debugger option) 409
 Erase main memory (C-SPY FET Debugger option) 409
 --erase_exclude (C-SPY command line option) 384
 --erase_exclude_all (C-SPY command line option) 385
 --erase_ip_protected (C-SPY command line option). . . . 385
 --erase_main (C-SPY command line option) 385
 --erase_main_and_info (C-SPY command line option) . . 386
 --erase_retain_file (C-SPY command line option) 386
 --erase_retain_target (C-SPY command line option) . . . 386
 __evaluate (C-SPY system macro) 331
 Evaluate Now (Macro Quicklaunch window context menu) 371
 examples
 C-SPY macros 313
 interrupts
 interrupt logging 274
 timer 272
 macros
 checking status of register 315
 creating a log macro 316
 using Quick Watch 315
 performing tasks and continue execution 118
 tracing incorrect function arguments 117
 execUserExecutionStarted (C-SPY setup macro) 324
 execUserExecutionStopped (C-SPY setup macro) 324
 execUserExit (C-SPY setup macro) 325
 execUserPreload (C-SPY setup macro) 323
 execUserPreReset (C-SPY setup macro). 325
 execUserReset (C-SPY setup macro) 325
 execUserSetup (C-SPY setup macro) 324
 executed code, covering 237
 execution history, tracing 184
 execution, stopping using the sequencer 305
 expressions. *See* C-SPY expressions
 Extended Clock Control dialog box 421
 extended command line file, for cspybat 387
 External code download (C-SPY FET option) 409

extra cycle counter 291
 Extra Options, for C-SPY 404

F

-f (cspybat option). 387
 FET Debugger (C-SPY driver)
 communication 422
 hardware installation 42
 File format (Memory Save option) 153
 file types
 device description, specifying in IDE 44
 macro 44, 403
 filename extensions
 ddf, selecting device description file 44
 mac, using macro file. 44
 sfr, register definitions for C-SPY 164
 Filename (Memory Restore option) 154
 Filename (Memory Save option) 154
 Fill dialog box. 155
 __fillMemory8 (C-SPY system macro) 332
 __fillMemory16 (C-SPY system macro). 333
 __fillMemory32 (C-SPY system macro). 334
 Find in Trace dialog box. 193
 Find in Trace window 194
 Find in Trace (Disassembly window context menu) 70
 Find (Memory window context menu) 152
 Find (Trace toolbar) 185
 first activation time (interrupt property), definition of . . . 268
 First activation (Edit Interrupt option) 277
 flash memory, load library module to 336
 flash memory, single-stepping in C-SPY emulator 60
 __fmessage (C-SPY macro keyword) 321
 for (macro statement) 321
 Force hardware RST/NMI (Emulator menu). 417
 Force Single Stepping (Emulator menu) 417
 Force (Forced Interrupt window context menu) 279
 Forced Interrupt window. 278
 Forced Interrupts (Simulator menu) 415

Format (Registers User Groups Setup window context menu)	167
formats, C-SPY input	35
Function Profiler window	230
Function Profiler (Simulator menu)	414
Function Trace window	188
functions	
C-SPY running to when starting	44, 402
most time spent in, locating	225
--function_profiling (cspybat option)	387
fuse, blowing on the target device.	419

G

General Clock Control dialog box	420
__getSelectedCore (C-SPY system macro).	335
GIE on/off (Emulator menu).	417
Go To Source (Timeline window context menu)	217, 221, 289
Go (Debug menu)	62

H

hardware setup, power consumption because of	247
--hardware_multiplier (C-SPY command line option)	388
highlighting, in C-SPY	62
Hold time (Edit Interrupt option)	278
hold time (interrupt property), definition of	269
--hwmult_type (C-SPY command line option)	388

I

icons, in this guide	28
if else (macro statement).	320
if (macro statement)	320
Ignore (Report Assert option)	78
Images window.	54
Images, loading multiple.	403
immediate breakpoints, overview	109

Include (Log File option)	77
Init New Device (Emulator menu)	418
input formats, C-SPY	35
Input Mode dialog box	74
input, special characters in Terminal I/O window.	74
installation directory	27
Instruction Profiling (Disassembly window context menu)	69
Intel-extended, C-SPY input format	35
Intel-extended, C-SPY output format	38
Intel-Standard, C-SPY input format	35
interference, power consumption because of	247
interrupt handling, power consumption during	246
Interrupt Log graph in Timeline window	287
Interrupt Log Summary window	284
Interrupt Log window	281
Interrupt Setup dialog box	275
Interrupt Setup (Simulator menu)	415
Interrupt Status window	279
interrupt system, using device description file	271
Interrupt (Edit Interrupt option)	277
Interrupt (Timeline window context menu).	289
interrupts	
adapting C-SPY system for target hardware	271
simulated, introduction to	267
timer, example	272
using system macros	270
__isBatchMode (C-SPY system macro)	335
italic style, in this guide	27–28

J

JTAG password (C-SPY FET Debugger option)	410
JTAG pins, shared with port pins	422
JTAG speed (C-SPY FET Debugger option)	408
--jtag_speed (C-SPY command line option)	389

L

labels (assembler), viewing.	86
--------------------------------------	----

Leave Target Running (Emulator menu) 417
 --leave_target_running (C-SPY command line option) . . . 390
 Length (Fill option) 155
 library functions
 C-SPY support for using, plugin module 393
 online help for 26
 lightbulb icon, in this guide 28
 linker options
 typographic convention 28
 consuming breakpoints 112
 Little Endian (Memory window context menu) 151
 Live Watch window 93
 __loadImage (C-SPY system macro) 335
 loading multiple debug files, list currently loaded 54
 loading multiple images 47
 Locals window 89
 lock device permanently 410
 log breakpoints, overview 108
 Log File dialog box 77
 loop statements, in C-SPY macros 321
 low-power mode, power consumption during 244
 --lpt1 (C-SPY command line option) 390
 --lpt2 (C-SPY command line option) 390
 --lpt3 (C-SPY command line option) 390

M

mac (filename extension), using a macro file 44
 --macro (C-SPY command line option) 390
 macro files, specifying 44, 403
 Macro Quicklaunch window 370
 Macro Registration window 366
 macro statements 320
 macros
 executing 313
 using 311
 --macro-param (C-SPY command line option) 391
 main function, C-SPY running to when starting 44, 402
 --mapu (C-SPY command line option) 391

Mask (Advanced Trigger breakpoints option) 135
 Mask (Conditional breakpoints option) 133
 Memory access checking (Memory Access Setup option) 174
 Memory Access Setup dialog box 173
 Memory Access Setup (Simulator menu) 414
 memory contents, writing to a file 176
 Memory Dump dialog box 176
 Memory Fill (Memory window context menu) 152
 memory map 173
 Memory Restore dialog box 154
 Memory Restore (Memory window context menu) 152
 Memory Save dialog box 153
 Memory Save (Memory window context menu) 152
 Memory window 149
 memory zones 142
 in device description file 143
 __memoryRestore (C-SPY system macro) 336
 __memorySave (C-SPY system macro) 337
 menu bar, C-SPY-specific 50
 __message (C-SPY macro keyword) 321
 __messageBoxYesCancel (C-SPY system macro) 338
 __messageBoxYesNo (C-SPY system macro) 339
 Messages window, amount of output 76
 migration, from earlier IAR compilers 26
 MISRA C, documentation 26
 Mixed Mode (Disassembly window context menu) 70
 Mode (Advanced Cycle Counter option) 296
 Motorola, C-SPY input format 35
 Motorola, C-SPY output format 38
 Move to PC (Disassembly window context menu) 68
 --mspdlogfile (C-SPY command line option) 392

N

Name (Edit SFR option) 171
 naming conventions 28
 Navigate (Sampled Graphs window context menu) 212
 Navigate (Timeline window context menu) . . . 216, 219, 288
 Next Symbol (Symbolic Memory window context menu) 158

O

--odd_word_check (C-SPY command line option)	392
__openFile (C-SPY system macro)	339
Operation (Fill option)	155
Operator (Advanced Trigger breakpoints option)	135
Operator (Conditional breakpoints option)	132
operators, sizeof in C-SPY	84
optimizations, effects on variables	84
options	
in the IDE	401
on the command line	378, 404
Options (Stack window context menu)	162
__orderInterrupt (C-SPY system macro)	340
Originator (debugger option)	406

P

-p (C-SPY command line option)	392
__param (C-SPY macro keyword)	319
parameters	
tracing incorrect values of	63
typographic convention	27
part number, of this guide	2
peripheral units	
debugging power consumption for	241
detecting mistakenly unattended	245
detecting unattended	245
device-specific	48
displayed in Registers window	142
in an event-driven system	246
in C-SPY expressions	83
initializing using setup macros	312
Please select one symbol (Resolve Symbol Ambiguity option)	105
--plugin (C-SPY command line option)	393
plugin modules (C-SPY)	38
loading	45
Plugins (C-SPY options)	405

__popSimulatorInterruptExecutingStack (C-SPY system macro)	341
pop-up menu. <i>See</i> context menu	
--port (C-SPY command line option)	393
port pins, shared with JTAG pins	422
power consumption, measuring	226, 241
Power graph in Timeline window	257
Power Log Setup window	252
Power Log window	254
power sampling	226
prerequisites, programming experience	23
Previous Symbol (Symbolic Memory window context menu)	158
probability (interrupt property)	278
definition of	268
Probability % (Edit Interrupt option)	278
Profile Selection (Timeline window context menu)	218
profiling	
analyzing data	228
on function level	227
on instruction level	229
using MSP430 advanced cycle counter	293
profiling information, on functions and instructions	225
profiling sources	
trace (calls)	226
trace (flat)	226
program execution	
breaking	108–109
in C-SPY	57
program flow, monitoring	299
program states, monitoring	299
programming experience	23
program. <i>See</i> application	
projects, for debugging externally built applications	46
--protocol (C-SPY command line option)	394
publication date, of this guide	2

Q

- Quick Watch window 99
- executing C-SPY macros 315

R

- Range breakpoints dialog box 129
- range breakpoints, overview 109
- Range for (Viewing Range option) 222
- Reaction trigger (Advanced Cycle Counter option) 298
- __readFile (C-SPY system macro) 342
- __readFileByte (C-SPY system macro) 343
- reading guidelines 23
- __readMemoryByte (C-SPY system macro) 343
- __readMemory8 (C-SPY system macro) 343
- __readMemory16 (C-SPY system macro) 344
- __readMemory32 (C-SPY system macro) 344
- reference information, typographic convention 28
- register groups 142
 - predefined, enabling 163
- Register User Groups Setup window 166
- registered trademarks 2
- __registerMacroFile (C-SPY system macro) 345
- Registers window 163
- registers, displayed in Registers window 163
- Release JTAG on Go (Emulator menu) 417
- Removal All Groups (Registers User Groups Setup window context menu) 167
- Remove All (Macro Quicklaunch window context menu) 371
- Remove (Macro Quicklaunch window context menu) . . 371
- Remove (Registers User Groups Setup window context menu) 167
- Repeat interval (Edit Interrupt option) 277
- repeat interval (interrupt property), definition of 268
- Replace (Memory window context menu) 152
- Report Assert dialog box 78
- Reset Counter (Advanced Cycle Counter option) 298
- Reset States (Sequencer option) 310

- Reset Trigger (Sequencer option) 310
- __resetFile (C-SPY system macro) 345
- Resolve Source Ambiguity dialog box 138
- Restore (Memory Restore option) 154
- restore_fram_memory (C-SPY command line option) . . 394
- Resynchronize JTAG (Emulator menu) 417
- Retain TLV data (C-SPY FET Debugger option) 410
- Retain unchanged memory (C-SPY FET Debugger option) 409
- retain_fram_memory (C-SPY command line option) . . 394
- return (macro statement) 321
- ROM-monitor, definition of 38
- RTOS awareness debugging 35
- RTOS awareness (C-SPY plugin module) 35
- Run to Cursor (Disassembly window context menu) 68
- Run to Cursor, command for executing 62
- Run to (C-SPY option) 44, 402

S

- Sampled Graphs window 211
- Save Custom SFRs (SFR Setup window context menu) . . 171
- Save to File (Register User Groups Setup window context menu) 168
- Save to File (Timeline window context menu) 217
- Save (Memory Save option) 154
- Save (Trace toolbar) 185
- Scale (Viewing Range option) 223
- scripting C-SPY. *See* macros
- Secure - Blow JTAG Fuse (Emulator menu) 419
- Select Graphs (Sampled Graphs window context menu) . . 214
- Select Graphs (Timeline window context menu) 217, 221, 289
- Select plugins to load (debugger option) 405
- __selectCore (C-SPY system macro) 345
- Sequencer Control window 309
- Sequencer Control (Emulator menu) 418
- sequencer, setting up 306
- Set Data Breakpoint (Memory window context menu) . . . 152

Set Data Log Breakpoint (Memory window context menu)	153	simulator, introduction	40
Set Next Statement (Disassembly window context menu) . 70		Size (Edit SFR option)	172
__setAdvancedTriggerBreak (C-SPY system macro)	346	Size (Sampled Graphs window context menu)	214
__setCodeBreak (C-SPY system macro)	347	Size (Timeline window context menu)	221
__setConditionalBreak (C-SPY system macro)	348	sizeof	84
__setDataBreak (C-SPY system macro)	349	__smessage (C-SPY macro keyword)	321
__setDataLogBreak (C-SPY system macro)	351	software delay, power consumption during	244
__setLogBreak (C-SPY system macro)	352	Solid Graph (Sampled Graphs window context menu)	214
__setRangeBreak (C-SPY system macro)	353	Solid Graph (Timeline window context menu)	221
__setSimBreak (C-SPY system macro)	354	Sort by (Timeline window context menu)	289
Settling time (C-SPY FET option)	408	__sourcePosition (C-SPY system macro)	357
--settlingtime (C-SPY command line option)	396	special function registers (SFR)	
__setTraceStartBreak (C-SPY system macro)	355	description files	164
__setTraceStopBreak (C-SPY system macro)	356	using as assembler symbols	83
setup macro file, registering	44	Stack window	159
setup macro functions	312	standard C, sizeof operator in C-SPY	84
reserved names.	323	Start address (Fill option)	155
Setup macros (debugger option)	403	Start address (Memory Save option)	153
Setup (C-SPY options)	402	Start (Advanced Cycle Counter option)	297
Setup (FET debugger options)	407	State Log graph (Timeline window)	264
--set_exit_breakpoint (C-SPY command line option)	395	State Log Setup window	258
--set_getchar_breakpoint (C-SPY command line option) . 395		State Log Summary window	261
--set_putchar_breakpoint (C-SPY command line option) . 395		State Log window	259
SFR, using as assembler symbols	83	state storage	
SFR Setup window	168	setting up	300
shortcut menu. <i>See</i> context menu		starting using the sequencer	305
Show All (SFR Setup window context menu)	170	State Storage Control window	301
Show Custom SFRs only (SFR Setup window context menu)	170	State Storage Control (Emulator menu)	418
Show Factory SFRs only (SFR Setup window context menu)	170	State Storage window	303
Show Numerical Value (Timeline window context menu)	214, 221	static analysis, documentation for	26
Show offsets (Stack window context menu)	161	Statics window	96
Show variables (Stack window context menu)	161	stdin and stdout, redirecting to C-SPY window	74
--silent (C-SPY command line option)	396	Step Into, description	59
Simulated Frequency dialog box	419	Step Out, description.	60
simulating interrupts, enabling/disabling	275	Step Over, description.	59
Simulator menu.	414	step points, definition of	58
		Stop (Advanced Cycle Counter option)	297
		stopping execution using the sequencer	305
		__strFind (C-SPY system macro)	357

__subString (C-SPY system macro)	358
Symbolic Memory window	156
Symbols window	102
symbols, in C-SPY expressions	82
System breakpoints on (C-SPY FET Debugger option)	411
__system1 (C-SPY system macro)	358
__system2 (C-SPY system macro)	359
__system3 (C-SPY system macro)	360

T

target system, definition of	37
Target VCC (C-SPY FET Debugger option)	408
__targetDebuggerVersion (C-SPY system macro)	360
Terminal IO Log Files (Terminal IO Log Files option)	75
Terminal I/O Log Files dialog box	74
Terminal I/O window	64, 73
terminology.	27
Text search (Find in Trace option)	193
TI msp430-txt, C-SPY input format	35
TI msp430-txt, C-SPY output format	38
Time Axis Unit (Timeline window context menu)	217, 221, 289
Timeline window	287
power graph	257
Timeline window (Call Stack graph)	215
Timeline window (Data Log graph)	218
Timeline window (State Log graph)	264
--timeout (C-SPY command line option)	396
timer interrupt, example	272
Toggle Breakpoint (Code) (Disassembly window context menu)	69
Toggle Breakpoint (Log) (Disassembly window context menu)	69
Toggle Breakpoint (Trace Start) (Disassembly window context menu)	69
Toggle Breakpoint (Trace Stop) (Disassembly window context menu)	69
Toggle source (Trace toolbar)	185
__toLower (C-SPY system macro)	361
tools icon, in this guide	28
__toString (C-SPY system macro)	361
__toUpper (C-SPY system macro)	362
trace	181, 195
Trace Expressions window	191
Trace Start Trigger breakpoint dialog box	189
trace start/stop trigger breakpoints, overview	108
Trace Stop Trigger breakpoint dialog box.	190
Trace window	184
trace (calls), profiling source	226
trace (flat), profiling source	226
trace, in Timeline window	257
trace, state storage being variant of	299
trademarks	2
Type (Advanced Trigger breakpoints option)	134
Type (Conditional breakpoints option)	131
typographic conventions	27

U

UBROF.	35
Unavailable, C-SPY message	85
Universal Binary Relocatable Object Format. <i>See</i> UBROF	
__unloadImage(C-SPY system macro)	362
Use command line options (debugger option)	404
Use Extra Images (debugger option)	403
Use manual ranges (Memory Access Setup option)	174
Use only emulated breakpoints (FET Debugger option)	212, 411
Use ranges based on (Memory Access Setup option)	173
Use software breakpoints (C-SPY FET Debugger option)	411
user application, definition of	37
--use_emulated_breakpoints (C-SPY command line option)	397
--use_virtual_breakpoints (C-SPY command line option)	397

V

Value (Advanced Trigger breakpoints option)	135
---	-----

Value (Fill option)	155
__var (C-SPY macro keyword).	318
variables	
effects of optimizations	84
in C-SPY expressions	82
information, limitation on	84
variance (interrupt property), definition of	269
Variance % (Edit Interrupt option)	278
--vccvoltage (C-SPY command line option).	397
Verify download (debugger option)	409
--verify_all (C-SPY command line option).	397
version number, of this guide	2
Viewing Range dialog box	222
Viewing Range (Sampled Graphs window context menu)	214
Viewing Range (Timeline window context menu)	221
virtual breakpoints, configuring	411
Visual State, C-SPY plugin module for	39

W

waiting for device, power consumption during	244
__wallTime_ms (C-SPY system macro).	363
warnings icon, in this guide	28
Watch window	91
using	81
web sites, recommended	27
while (macro statement)	321
windows, specific to C-SPY	53
With I/O emulation modules (linker option), using.	74
__writeFile (C-SPY system macro)	363
__writeFileByte (C-SPY system macro).	364
__writeMemoryByte (C-SPY system macro)	364
__writeMemory8 (C-SPY system macro).	364
__writeMemory16 (C-SPY system macro).	365
__writeMemory32 (C-SPY system macro).	365

Z

zone	
defined in device description file	143
in C-SPY	142
part of an absolute address.	137
Zone (Edit SFR option).	172
Zoom (Sampled Graphs window context menu).	213
Zoom (Timeline window context menu).	217, 220, 288

Symbols

__abortLaunch (C-SPY system macro).	328
__cancelAllInterrupts (C-SPY system macro)	328
__cancelInterrupt (C-SPY system macro).	329
__clearBreak (C-SPY system macro)	329
__closeFile (C-SPY system macro)	329
__delay (C-SPY system macro)	330
__disableInterrupts (C-SPY system macro)	330
__driverType (C-SPY system macro)	330
__enableInterrupts (C-SPY system macro).	331
__evaluate (C-SPY system macro)	331
__fillMemory8 (C-SPY system macro)	332
__fillMemory16 (C-SPY system macro).	333
__fillMemory32 (C-SPY system macro).	334
__fmessage (C-SPY macro keyword)	321
__getSelectedCore (C-SPY system macro).	335
__isBatchMode (C-SPY system macro)	335
__loadImage (C-SPY system macro)	335
__memoryRestore (C-SPY system macro)	336
__memorySave (C-SPY system macro)	337
__message (C-SPY macro keyword)	321
__messageBoxYesCancel (C-SPY system macro)	338
__messageBoxYesNo (C-SPY system macro)	339
__openFile (C-SPY system macro).	339
__orderInterrupt (C-SPY system macro).	340
__param (C-SPY macro keyword)	319
__popSimulatorInterruptExecutingStack (C-SPY system macro).	341

__readFile (C-SPY system macro)	342	-d (C-SPY command line option)	382
__readFileByte (C-SPY system macro)	343	-f (cspybat option)	387
__readMemoryByte (C-SPY system macro)	343	-p (C-SPY command line option)	392
__readMemory8 (C-SPY system macro)	343	--allow_access_to_BSL (C-SPY command line option)	378
__readMemory16 (C-SPY system macro)	344	--allow_locked_flash_access (C-SPY command line option)	378
__readMemory32 (C-SPY system macro)	344	--application_args (C-SPY command line option)	379
__registerMacroFile (C-SPY system macro)	345	--attach_to_running_target (C-SPY command line option)	379
__resetFile (C-SPY system macro)	345	--backend (C-SPY command line option)	380
__selectCore (C-SPY system macro)	345	--code_coverage_file (C-SPY command line option)	381
__setAdvancedTriggerBreak (C-SPY system macro)	346	--connection (C-SPY command line option)	380
__setCodeBreak (C-SPY system macro)	347	--cycles (C-SPY command line option)	381
__setConditionalBreak (C-SPY system macro)	348	--debug_file (cspybat option)	382
__setDataBreak (C-SPY system macro)	349	--derivative (C-SPY command line option)	383
__setDataLogBreak (C-SPY system macro)	351	--disable_interrupts (C-SPY command line option)	383
__setLogBreak (C-SPY system macro)	352	--disable_memory_cache (C-SPY command line option)	383
__setRangeBreak (C-SPY system macro)	353	--download_only (C-SPY command line option)	383
__setSimBreak (C-SPY system macro)	354	--eem (C-SPY command line option)	384
__setTraceStartBreak (C-SPY system macro)	355	--erase_exclude (C-SPY command line option)	384
__setTraceStopBreak (C-SPY system macro)	356	--erase_exclude_all (C-SPY command line option)	385
__smessage (C-SPY macro keyword)	321	--erase_ip_protected (C-SPY command line option)	385
__sourcePosition (C-SPY system macro)	357	--erase_main (C-SPY command line option)	385
__strFind (C-SPY system macro)	357	--erase_main_and_info (C-SPY command line option)	386
__subString (C-SPY system macro)	358	--erase_retain_file (C-SPY command line option)	386
__system1 (C-SPY system macro)	358	--erase_retain_target (C-SPY command line option)	386
__system2 (C-SPY system macro)	359	--function_profiling (cspybat option)	387
__system3 (C-SPY system macro)	360	--hardware_multiplier (C-SPY command line option)	388
__targetDebuggerVersion (C-SPY system macro)	360	--hwmult_type (C-SPY command line option)	388
__toLower (C-SPY system macro)	361	--jtag_speed (C-SPY command line option)	389
__toString (C-SPY system macro)	361	--leave_target_running (C-SPY command line option)	390
__toUpper (C-SPY system macro)	362	--lpt1 (C-SPY command line option)	390
__unloadImage (C-SPY system macro)	362	--lpt2 (C-SPY command line option)	390
__var (C-SPY macro keyword)	318	--lpt3 (C-SPY command line option)	390
__wallTime_ms (C-SPY system macro)	363	--macro (C-SPY command line option)	390
__writeFile (C-SPY system macro)	363	--macro_param (C-SPY command line option)	391
__writeFileByte (C-SPY system macro)	364	--mapu (C-SPY command line option)	391
__writeMemoryByte (C-SPY system macro)	364	--mspdlogfile (C-SPY command line option)	392
__writeMemory8 (C-SPY system macro)	364	--odd_word_check (C-SPY command line option)	392
__writeMemory16 (C-SPY system macro)	365	--plugin (C-SPY command line option)	393
__writeMemory32 (C-SPY system macro)	365	--port (C-SPY command line option)	393

--protocol (C-SPY command line option)	394
--restore_fram_memory (C-SPY command line option) . . .	394
--retain_fram_memory (C-SPY command line option) . . .	394
--settlingtime (C-SPY command line option)	396
--set_exit_breakpoint (C-SPY command line option) . . .	395
--set_getchar_breakpoint (C-SPY command line option) .	395
--set_putchar_breakpoint (C-SPY command line option) .	395
--silent (C-SPY command line option)	396
--timeout (C-SPY command line option)	396
--use_emulated_breakpoints (C-SPY command line option)	397
--use_virtual_breakpoints (C-SPY command line option).	397
--vccvoltage (C-SPY command line option)	397
--verify_all (C-SPY command line option)	397

Numerics

1x Units (Symbolic Memory window context menu) . . .	158
8x Units (Memory window context menu)	151