



**HAL**  
open science

# Stochastic Modeling of WiFi's EDCA and Double Frequency Reuse for Femtocell

Yoram Haddad

► **To cite this version:**

Yoram Haddad. Stochastic Modeling of WiFi's EDCA and Double Frequency Reuse for Femtocell. Networking and Internet Architecture [cs.NI]. Télécom ParisTech, 2010. English. NNT: . pastel-00561406

**HAL Id: pastel-00561406**

**<https://pastel.hal.science/pastel-00561406>**

Submitted on 1 Feb 2011

**HAL** is a multi-disciplinary open access archive for the deposit and dissemination of scientific research documents, whether they are published or not. The documents may come from teaching and research institutions in France or abroad, or from public or private research centers.

L'archive ouverte pluridisciplinaire **HAL**, est destinée au dépôt et à la diffusion de documents scientifiques de niveau recherche, publiés ou non, émanant des établissements d'enseignement et de recherche français ou étrangers, des laboratoires publics ou privés.



# Thèse

présentée pour obtenir le grade de Docteur  
de Télécom ParisTech

**Spécialité : Informatique et Réseaux**

**Yoram HADDAD**

**Modélisation Stochastique du Mécanisme EDCA du WiFi  
et Double Réutilisation de Fréquences pour les  
Femtocells**

Soutenue le 13 Septembre 2010 devant le jury composé de

Pr. Samir Tohme	Président
Pr. André-Luc Beylot	Rapporteurs
Pr. Jay Weitzen	
Pr. Simon Bloch	Examineur
M. Jacques Bensimon	
Pr. Noémie Simoni	Directeurs de thèse
Dr. Gwendal Le Grand	



# PhD Thesis

Dissertation submitted in partial fulfillment of the  
requirement for the degree of

Doctor of Philosophy

of Graduate School TELECOM ParisTech

In: **Computer Science and Networks**

by **Yoram HADDAD**

**Modeling of WiFi's EDCA and Double frequency reuse for  
Femtocell**

Presented the 13<sup>th</sup> of September 2010 before the jury composed of

Prof. Samir Tohme	President
Prof. André-Luc Beylot	Reviewer
Prof. Jay Weitzen	Reviewer
Prof. Simon Bloch	Examiner
M. Jacques Bensimon	Examiner
Prof. Noémie Simoni	Advisor
Dr. Gwendal Le Grand	Advisor

# Contents

<b>List of Figures</b>	<b>6</b>
<b>List of Tables</b>	<b>8</b>
<b>Glossary</b>	<b>9</b>
<b>Acknowledgements</b>	<b>14</b>
<b>Abstract</b>	<b>16</b>
<b>Résumé-French Synthesis</b>	<b>17</b>
<b>1 Introduction</b>	<b>51</b>
1.1 "Ubiquitous Wireless" . . . . .	51
1.2 Challenges . . . . .	52
1.2.1 Capacity Evaluation of a Wifi Cell . . . . .	53
1.2.2 Qos Parameters for WiFi . . . . .	53
1.3 Thesis Goals and Contributions . . . . .	54
1.3.1 Stochastic Model for Wifi Access . . . . .	54
1.3.2 Femtocell . . . . .	55
1.4 Thesis Outline . . . . .	56
<b>I Background and state of the ART</b>	<b>57</b>
<b>2 Access Mechanisms to IEEE 802.11 WiFi Networks and Their Analytical Model</b>	<b>59</b>
2.1 MAC of the IEEE 802.11 and 802.11e description . . . . .	59
2.1.1 introduction . . . . .	59
2.1.2 Distributed Coordination Function . . . . .	61

2.1.3	Enhanced Distributed Coordinated Access function . .	63
2.2	State of The ART . . . . .	65
2.2.1	Seminal Models . . . . .	66
2.2.2	DCF models . . . . .	67
2.2.3	EDCA models . . . . .	68
2.2.4	Summary Table . . . . .	68
<b>3</b>	<b>Frequency Allocation to Femtocell</b>	<b>70</b>
3.1	Introduction . . . . .	70
3.2	Description . . . . .	71
3.2.1	Access Control . . . . .	72
3.3	Challenges . . . . .	73
3.3.1	Femtocell to Macrocell Downlink Interference . . . . .	73
3.3.2	Macrocell to Femtocell Uplink Interference . . . . .	73
3.3.3	Femtocell to Femtocell Uplink Interference . . . . .	74
3.3.4	Femtocell to Femtocell Downlink Interference . . . . .	74
3.4	Existing Allocation Scheme . . . . .	74
3.4.1	Introduction . . . . .	75
3.4.2	Experimental Results in the Literature . . . . .	76
3.4.3	Cross-Tier Allocation Scheme . . . . .	76
3.4.4	Co-tier allocation scheme . . . . .	79
<b>II</b>	<b>Our Proposition</b>	<b>83</b>
<b>4</b>	<b>Stochastic Model of EDCA</b>	<b>84</b>
4.1	System Model . . . . .	84
4.1.1	Four Dimensional Markov Chain . . . . .	84
4.1.2	Markov Chain . . . . .	87
4.1.3	Characteristic of Our Model: the Unsaturated Mode . . . . .	88
4.1.4	Transition probabilities . . . . .	88
4.1.5	Probability in steady state and equation systems . . . . .	93
4.2	Throughput derivation . . . . .	102
4.3	Delay derivation . . . . .	103
<b>5</b>	<b>Frequency allocation to femtocell a double frequency reuse assignment scheme</b>	<b>106</b>
5.1	Double Frequency Reuse: A novel Channel Allocation Scheme for Femtocells . . . . .	106
5.2	Femtocell's Channel Selection . . . . .	109

5.3	Other Fundamentals Parameters . . . . .	109
5.3.1	Radio Resource Granularity . . . . .	110
5.3.2	Femtocell Transmission Power . . . . .	112
5.3.3	Adjacent Channel Interference . . . . .	113
<b>III</b>	<b>Results</b>	<b>114</b>
<b>6</b>	<b>Analytical Results of the Stochastic Model of EDCA</b>	<b>115</b>
6.1	Equations System . . . . .	115
6.2	Unsaturated mode and error prone channel effects on the throughput . . . . .	118
6.3	AIFS and CWmin differentiation mechanism . . . . .	122
6.3.1	AIFS mechanism . . . . .	122
6.3.2	CWmin mechanism . . . . .	122
6.4	Some delay results . . . . .	124
<b>7</b>	<b>Simulation and Results for Femtocell Channels Reuse</b>	<b>129</b>
7.1	Performance derivation . . . . .	129
7.2	Simulation Parameters . . . . .	130
7.2.1	Propagation Models . . . . .	131
7.3	Macrocell-Femtocell Simulator . . . . .	132
7.4	Results . . . . .	139
7.4.1	Introduction . . . . .	139
7.4.2	Femtocell RSS Performance . . . . .	140
7.4.3	Femtocell SINR Performance . . . . .	144
7.4.4	Effect of the Transmission Power . . . . .	146
<b>8</b>	<b>Conclusion</b>	<b>153</b>
<b>9</b>	<b>Appendix :Fixed Point Theorem Method</b>	<b>157</b>
	<b>Bibliography</b>	<b>161</b>
	<b>Publications</b>	<b>169</b>

# List of Figures

2.1	DCF interframe space . . . . .	62
2.2	DCF access method . . . . .	62
2.3	RTS-CTS protection and NAV . . . . .	62
2.4	MAC architecture . . . . .	64
2.5	Mapping to one of the AC . . . . .	65
2.6	AIFS prioritization mechanism of EDCA . . . . .	66
3.1	Femtocell-to-Femtocell Uplink Attack . . . . .	74
4.1	A Frozen Period . . . . .	86
4.2	Collisions and Errors . . . . .	87
4.3	The full Markov chain . . . . .	100
4.4	Simplified Markov Chain . . . . .	101
5.1	Frequency reuse scheme . . . . .	108
6.1	Throughput under different traffic loads . . . . .	119
6.2	Throughput under different error-prone environments vs. packet size . . . . .	120
6.3	Throughput vs. Number of active stations in unsaturated mode . . . . .	121
6.4	Impact of AIFS differentiation on the throughput in saturated mode . . . . .	123
6.5	AIFS differentiation under different traffic loads . . . . .	124
6.6	Impact of CWmin differentiation on the throughput in saturated mode . . . . .	125
6.7	CWmin differentiation under different traffic loads . . . . .	126
6.8	Delay differentiation under different traffic loads . . . . .	128
6.9	Delay experienced with different number of stations . . . . .	128
7.1	first interface to the simulator: entering initial parameters . . . . .	133

7.2	Distribution of MUE, and FAP . . . . .	134
7.3	Selection of the scheme . . . . .	135
7.4	Mixed Scheme display . . . . .	136
7.5	Patial scheme display . . . . .	137
7.6	Display of Uplink results . . . . .	138
7.7	Display of Downlink results . . . . .	138
7.8	Numerical Results for RSS and SINR . . . . .	139
7.9	RSS in Downlink with uniform distribution . . . . .	141
7.10	RSS in Uplink with uniform distribution . . . . .	141
7.11	RSS in Downlink with concentration at the edge . . . . .	142
7.12	RSS in Uplink with concentration at the edge . . . . .	142
7.13	RSS in Downlink with concentration in the center . . . . .	143
7.14	RSS in Uplink with concentration in the center . . . . .	143
7.15	Downlink SINR with uniform distribution . . . . .	144
7.16	Uplink SINR with uniform distribution . . . . .	145
7.17	Downlink SINR CDF with uniform distribution . . . . .	145
7.18	Uplink SINR CDF with uniform distribution . . . . .	146
7.19	Downlink SINR with edge deployment . . . . .	147
7.20	Uplink SINR with edge deployment . . . . .	147
7.21	Effect of the MAP Tx power on the RSS femtocell Downlink transmission . . . . .	148
7.22	Effect of the MAP Tx power on the SINR femtocell Downlink transmission . . . . .	148
7.23	Effect of the FAP Tx power on the RSS femtocell Downlink transmission . . . . .	149
7.24	Effect of the FAP Tx power on the SINR femtocell Downlink transmission . . . . .	150
7.25	Effect of the MUE Tx power on the RSS femtocell Uplink transmission . . . . .	150
7.26	Effect of the MUE Tx power on the SINR femtocell Uplink transmission . . . . .	151
7.27	Effect of the FUE Tx power on the RSS femtocell Uplink transmission . . . . .	152
7.28	Effect of the FUE Tx power on the SINR femtocell Uplink transmission . . . . .	152



# List of Tables

2.1	State of the art summary and comparison of DCF and EDCA Stochastic models . . . . .	69
3.1	State of the art summary of frequency channel allocation scheme for macrocell and femtocell . . . . .	82
4.1	Variables and constants of the model . . . . .	85
6.1	EDCA Default Parameter Values . . . . .	118
7.1	Macrocell and Femtocell Scenario Default Parameter Values	140



# Acronyms

**3G** Third Generation.

**AC** Access Category.

**ACI** Adjacent Channel Interference.

**ACLR** Adjacent Channel Leakage power Ratio.

**ACS** Adjacent Channel Selectivity.

**AMC** Adaptive Modulation and Coding.

**AP** Access Point.

**BER** Bit Error Rate.

**BS** Base Station.

**CCI** Co-Channel Interference.

**CDF** Cumulative Distribution Function.

**CDMA** Code Division Multiple Access.

**CINR** Carrier to Interference and Noise Ratio.

**CSG** Closed Subscriber Group.

**CSMA / CA** Carrier Sense Multiple Access with Collision Avoidance.

**CSMA/CD** Carrier Sense Multiple Access with Collision Detection.

**CTS** Cordless Telephony System.

**CTS** Clear To Send.

**CW** Contention Window.

**DCA** Dynamic Channel Assignment.

**DCF** Distributed (Coordination Function) Interframe Space.

**DECT** Digital Enhanced Cordless Telecommunications.

**DIFS** Distributed InterFrame Space.

**EDCA** Enhanced Distributed Channel Access.

**EIRP** Equivalent Isotropically Radiated Power.

**ETSI** European Telecommunications Standards Institute.

**FAP** Femtocell Access Point.

**FCA** Fixed Channel Assignment.

**FDTD** Finite-Difference Time-Domain.

**FRF** Frequency Reuse Factor.

**FUE** Femtocell User Equipment.

**GPRS** General Packet Radio Service.

**GSM** Global System for Mobile communication.

**GUI** Graphical User Interface.

**HBS** Home Base Station.

**HCCA** HCF Controlled Channel Access.

**HCF** Hybrid Coordination Function.

**HSPA** High Speed Packet Access.

**IFS** Inter-Frame Space.

**LAN** Local Area Network.

**LTE** Long Term Evolution.

**MAC** Medium Access Control.

**MAP** Macrocell Access Point.

**MS** Mobile Station.

**MSDU** MAC Service Data Unit.

**MUE** Macrocell User Equipment.

**NAV** Network Allocation Vector.

**OFDM** Orthogonal Frequency Division Multiplexing.

**OFDMA** Orthogonal Frequency Division Multiple Access.

**PABX** Private Branch eXchange.

**PCF** Point Coordination Function.

**PHY** Physical Layer.

**QAP** QoS AP.

**QoS** Quality of Service.

**QSTA** QoS STA.

**RB** Resource Block.

**RSS** Received Signal Strength.

**RTS** Request To Send.

**SIFS** Short InterFrame Space.

**SINR** Signal to Interference and Noise Ratio.

**SNR** Signal to Noise Ratio.

**STA** Station.

**TDMA** Time Division Multiple Access.

**TFH** Total Frequency Hopping.

**UE** User Equipment.

**UMTS** Universal Mobile Telecommunication System.

**UWB** Ultra Wide Band.

**VoIP** Voice Over IP.

**WiFi** Wireless Fidelity.

**WiMAX** Wireless Interoperability for Microwave Access.

**WLAN** Wireless LAN.

# Acknowledgements

In my humble opinion, the basis for healthy human relationships is, the ability to recognize and appreciate all the good things we receive from others. So it is with a special pleasure, that with the achievement of this thesis, I use the opportunity to thank the people without whom this project would probably never have been completed.

First and foremost, I would like to thank the almighty, creator of the world, our G-od the holy blessed be he, for giving me the opportunity to sanctify his name in this world, to live in my father's land and perpetuate our tradition. My thanks also go to all of his emissaries:

To Prof. Daniel Kofman for allowing me to start this project, and for having led me towards interesting topics with great potential and to Prof. HG Mendelbaum for all the help he provided me from a logistical point of view and for having initiated this project.

To all the team of the Jerusalem College of Technology for their warm welcome, their constant encouragements, technical and financial support, especially: the President Prof. Noah Dana-Picard, the Rector Prof. Menachem Steiner, the Head of Computer Sc. Dept Dr. Motti Reif, and also to my colleagues Drs: A. Heuman, H. Dayan, I. Kidron, Y. Peretz, Y. Hachohen-Kerner, and S. Weinman. Finally to our best secretary, who is always willing to help in every circumstances: Mrs Chana Touitou.

My gratitude goes to Dr. Gwendal Le Grand, who supervised a large part of the thesis and from who I truly learned the job of a researcher. Thank you for your support, your confidence in my abilities (even though I sometimes lacked its). A big thank you to my "professional parents" who followed me during this long "trip" and encouraged me : to Prof. Noemie Simoni for supervising the thesis and to Jacques Bensimon, for all his efforts

to allow me to finish this thesis.

My sincere thanks to Dr. Dana Porrat for welcoming and mentoring me during my visit at the Hebrew University of Jerusalem. Thank you for the fruitful discussions that have undoubtedly permitted the completion of this project. Thank you to my dear childhood friend David Cabessa for making the best review of the English grammar work ever realized ...

I wish to thank the members of the jury chaired by Prof. Samir Tohme. To Profs Andre-Luc Beylot and Jay Weitzen for their thorough and comprehensive reports of this manuscript. To Prof Simon Bloch who was one of the examiners.

My warm thanks go to my parents in-law, Pierre and Annie Rubini, who helped us during all these years. To my uncles Hamiel, Yoski and Yoav for having always considered me as their own son and encouraged me to excel.

I would like to express my deep gratitude to my Rabbis who supported and encouraged me to finish the thesis, RAVs: Zvi I. Tau, Hannane Edelstein, David Giami, Amiel and Mordechai Sternberg, Joshua Zukerman. They are all for me a source of inspiration and moral support.

I want to express my deep gratitude to my parents who always ensured my well-being. You have given me confidence since my youth. This work is dedicated to you, and was worth it, even for the sole sake of seeing your eyes shine at the end of my PhD defense ... Thanks to my sister Avigael and her husband Shay for their support at any time, day and ...night

My final thanks go to my dearest wife, Sarah, at my side at all times. Thank you for your support, your encouragements, especially in difficult times. Thank you for the wonderful education you have given our children, often without me, during these long years. For all these long weeks, months and years when I was "just passing" at home. I apologize to my wonderful children for not being able to follow them during all these years, to: Shlomo (alias "shlomikoto"), Yehoudith ("kimo"), Hanna ("noun") and Tsipora ("chips").

Thank you my G-od for your infinite goodness renewed every day



## Abstract

The race toward higher throughputs for cellular network users is getting more difficult every day. On the one hand cellular network operators wish to increase benefits by offering new services to more users, while on the other hand spare radio resources are shrinking away. The spreading of WiFi-3G dual mode devices is making this fight even harder for the cellular operator. When arriving at home, users with dual mode devices automatically switch to their local wireless broadband connection, and make free calls through Voice over IP software. The new "Femtocell" technology is expected to be the rescuer of cellular network operators. This "home" cellular base station provides high indoor coverage and throughput to indoor users over the regular home broadband access connection to the internet. In this thesis, we evaluate the capacity that can be offered by the WiFi and Femtocell technologies separately. In the first part we propose a realistic and comprehensive model to analyze the performance of the IEEE 802.11e Enhanced Distributed Channel Access (EDCA) contention based access mechanism, which provides class-based Quality of Service (QoS) to IEEE 802.11 Wireless LANs (WLANs). Our analytical approach is based on Markov chains. Our innovation is that our model allows for non-ideal channels and unsaturated networks. The improved model allows computing and representing the performance more precisely for various traffic loads and various Bit Error Rates (BERs). Then we assess the performance of the femtocell approach. For this purpose, we first needed to deal with the radio planning issue. This latter issue is not obvious for a plug-and-play Femtocell device whose deployment will inherently be unpredictable. We propose a double frequency reuse scheme, which allows a femtocell to reuse the frequency already in use by adjacent sectors of the overlaying macrocell. We present three solutions: full, partial or mixed frequency reuse. Then we evaluate the performance that Femtocells can achieve when coexisting with an overlaying macrocell in terms of RSS and SINR expected at the femtocell level. We show that Femtocells can definitely provide a meaningful improvement in the data rates experienced by the femtocell user's equipment.

# Remerciements

La base de relations humaines saines est a mon humble avis la capacité de reconnaître et apprécier le bien que la société et les individus nous prodiguent. Ainsi c'est avec une satisfaction particulière que je peux, à l'aboutissement de cette thèse remercier les personnes sans qui ce projet n'aurait surement pas abouti.

En tout premier lieu, je remercie le tout puissant, créateur du monde, notre d.ieu le saint béni soit-il, de m'avoir donné la possibilité de sanctifier son nom dans ce monde, de vivre dans ma terre ancestrale et de perpétuer notre tradition. Mes remerciements vont également a l'ensemble de ses envoyés :

Au prof Daniel Kofman pour m'avoir permis de démarrer ce projet, et pour m'avoir dirigé vers des sujets intéressants et à fort potentiel. Au prof H.G. Mendelbaum, pour m'avoir aidé d'un point de vue logistique et qui fut l'initiateur du projet. A toutes les équipes du Jerusalem College of Technology, pour leur accueil chaleureux, leur encouragements permanents, leur soutien technique, logistique et financier, en particulier au président prof Noah Dana-Picard, au recteur Prof Menachem Steiner, au chef du dept Dr Motti Reif, ainsi qu'à mes collègues Dr A. Heuman, H. Dayan, Y. Peretz, Y. Hacohen-Kerner, et S. Weinman. Enfin a la personne dévouée qui nous aide en toute discretion : Chana Touitou.

Mes remerciements vont au Dr. Gwendal le Grand, qui a encadré une grande partie de la thèse et de qui j'ai appris véritablement le métier de chercheur. Merci pour ton soutien, ta confiance en mes capacités (même si moi-meme je n'étais pas confiant), ta rapidité de reponse aux e-mails (oui ça aussi ça aide beaucoup . . .).

Un grand merci a mes "parents professionnels" qui m'ont suivi et encour-

agé durant ce long parcours. Au prof Noemi Simoni pour avoir encadré la thèse et avoir permis l'aboutissement de ce périple marathon. A Jacques BenSimon, pour m'avoir encouragé à conclure un travail entamé.

Mes sincères remerciement au Dr Dana Porrat pour m'avoir accueilli et encadré durant ma visite à l'université hébraïque d'un point de vue technique et financier. Merci pour ces discussions fructueuses qui ont sans doute permis l'achèvement de ce projet. Merci a mon cher ami d'enfance David Cabessa pour avoir effectué le meilleur travail de correction jamais réalisé. . . .

Je souhaite remercier les membres du jury presidé par le prof Samir Tohme. Notamment les profs Andre-Luc Beylot et Jay Weitzen pour leur rapport complet et minutieux de ce manuscrit. Le prof S. Bloch pour avoir accepté d'être examinateur.

Mes chaleureux remerciements vont a mes beaux parents Pierre et Annie Rubini qui nous ont aidé durant toutes ces années. A mes oncles Hamiel, Yoski et Yoav pour m'avoir toujours suivi comme leur propre fils et encouragé à me dépasser.

Je tiens à exprimer ma profonde gratitude envers mes parents qui ont toujours veillé à mon bien-être. Vous m'avez donné confiance depuis mon plus jeune âge. Ce travail vous est consacré, ne serait-ce que pour voir vos yeux briller au moment de ma soutenance, . . . Merci a ma soeur Avigael et mon beau frère Shay pour leur soutien à tout heure du jour et . . . de la nuit.

Je désire exprimer ma profonde gratitude envers mes Rabbins qui m'ont soutenu et encouragé a terminer la thèse, Rav: Zvi I. Tau, Hannane Edelstein, David Giami, Amiel et Mordehai Sternberg, Yehochoua Zukerman. Ils sont tous pour moi une source d'inspiration et de support moral intarissable.

Enfin mes derniers remerciements, les plus chers, vont a ma femme Sarah, à mes cotés en toutes circonstances. Merci pour ton soutien, tes encouragements dans les moments difficiles. Merci pour l'éducation merveilleuse que tu as donné à nos enfants, souvent sans moi durant ces longues années. Pour toutes ces longues semaines, mois et années où je n'étais "que de passage" à la maison. Je demande pardon à mes merveilleux enfants de ne pas avoir pu les suivre durant toutes ces années, à : Shlomo ("shlomikoto"), Yehoudith ("kimo"), Hanna ("noun") et Tsipora ("chips").

Merci mon d.ieu pour ta bonté infinie renouvelée tout les jours.

# Résumé de la thèse en Français - Short Version of the Thesis in French

La course vers des débits plus élevés pour les utilisateurs de réseaux cellulaires devient plus difficile chaque jour. Les opérateurs de réseaux cellulaires souhaitent accroître leurs bénéfices en offrant de nouveaux services à un nombre croissant d'utilisateurs, mais la ressource radio disponible diminue en permanence. Le développement de téléphone cellulaire surnommé en anglais "dual-mode" (bi-mode) qui abrite au sein d'un même appareil les technologies cellulaires et le Wifi rend cette lutte encore plus ardue. En arrivant à la maison, un utilisateur disposant d'un appareil "bi-mode" basculera forcément vers sa connexion locale sans fil à haut débit et pourra ainsi jouir de services d'appels gratuits via des logiciels de Voix sur IP. La nouvelle technologie surnommée "Femtocell" est considérée comme le potentiel sauveur des opérateurs menacés par la concurrence du Wifi. Ce point d'accès résidentiel au réseau cellulaire offre une meilleure couverture et un plus haut débit aux utilisateurs situés en intérieur. Dans cette thèse, nous évaluons séparément, la capacité utile offerte par un point d'accès Wifi et par un point d'accès "Femtocell". Dans la première partie nous proposons un modèle réaliste du mécanisme d'accès à la ressource du Wifi. Ce mécanisme connu sous l'acronyme EDCA prévoit une différenciation des services requis par l'utilisateur. Notre modèle est basé sur les chaînes de Markov. Notre évitons les principales approximations faites dans les modèles antérieurs. Nous prenons en compte, un régime non saturé en prenant en compte un canal non idéal. Ainsi nous pouvons obtenir les performances attendues avec plus de précision pour différentes charges de trafic et divers taux d'erreur binaire (BER). Dans un second temps nous évaluons les performances des Femtocell. Pour ce, nous avons tout d'abord proposé une planification de la ressource

radio. L'allocation des fréquences est considérée comme un des principaux défis de cette nouvelle technologie, étant donné le déploiement imprévisible des Femtocell par leurs propres utilisateurs. Nous proposons dans cette thèse un schéma de "double" réutilisation des fréquences qui consiste à allouer au femtocell les fréquences déjà utilisées par les secteurs adjacents des macrocells avoisinantes. Trois solutions sont envisagées: réutilisation des fréquences pleines, partielles ou mixtes. Nous évaluons ensuite les performances des femtocells en termes de puissance de signal reçue et rapport signal à interférence plus bruit. Nous montrons que femtocells contribue à une amélioration significative par rapport à une couverture macrocell classique.

# Introduction

Avec l'apparition des "Smartphones" ou téléphone intelligent, nous entrons bel et bien dans une nouvelle ère. Celle de l'accessibilité des données " partout ", et " tout le temps ". Plus de 10 ans après l'explosion de la bulle internet, nous vivons actuellement l'explosion de la bulle " mobilité " qui est finalement la suite logique des nouveaux besoins créés par l'internet. Les possibilités offertes par internet en termes de communications (Skype, ICQ, Gmail, . . . ), informations (Wikipedia, . . . ), commerce et autres sont devenues " trop " omniprésentes dans notre quotidien pour pouvoir se confiner à un fil qui ne peut être branché que dans certains endroits.

Cependant l'attrait du sans fil n'est pas sans défis. En effet le canal sans fil est différent par essence de la filaire. De nombreux phénomènes physiques ne sont présents que dans le canal sans fil. Ainsi peu après les débuts des réseaux filaires dans les années 60 (ARPANET etc.), des protocoles destinés aux réseaux sans fils ont d'ors et déjà été envisagés (ALOHA par N. Abramson en 70). Il ya près de 25 ans le premier téléphone portable apparut. A l'époque l'utilisation principale envisagée fut le service vocal. Le service de courte messagerie " SMS " inclus dans les premiers standard GSM du début des années 1990 connut un succès bien au delà de l'espérance de ses concepteurs. Puis vint l'évolution des services de données avec le GPRS puis l'UMTS relayés par l'HSPA. En parallèle, l'accessibilité aux services de données a partir d'un poste fixe prit son essor avec l'avènement du standard wifi en 1997. Depuis, de nombreux standards complémentaires ont été développés comme le Bluetooth pour la courte portée et le faible débit, l'UWB pour le haut débit, et le WiMax pour la longue portée. A l'instar du téléphone cellulaire ces standards sont majoritairement destinés à supporter les services peu sensibles aux délais, donc majoritairement services de données (mail, web, ftp etc. . . ).

Cependant ces 2 groupes de standards à savoir téléphonie mobile et données fixes ont réussi au fil des années à évoluer pour offrir le haut débit déjà

existant pour les terminaux fixes même au téléphone mobile.

## L'ubiquité du sans fil

Il y a déjà plus d'un an que le monde du cellulaire a célébré le passage du cap des 4 milliards d'abonnés [38]. Pendant ce temps les réseaux cellulaires de troisième génération continuent d'être déployés et la 3.5 génération est déjà à l'horizon. Tous ces faits combinés prédisent un avenir confortable pour les opérateurs, bienvenu dans le contexte de la crise financière mondiale. Pour l'utilisateur final, cela signifie aussi que de nouveaux et meilleurs services seront disponibles. Toutefois, le problème de la couverture et la capacité est toujours d'actualité, et encore plus pour les utilisateurs à l'intérieur. Ainsi, une amélioration dans ce domaine serait appréciable en particulier d'autant plus que plusieurs enquêtes montrent que le trafic des utilisateurs situés en intérieur peut atteindre plus de 30% du trafic total.

De même on observe une frénésie dans le déploiement des réseaux WiFi. Les propriétaires de téléphones "dual-mode" basculent automatiquement vers leur connexion sans fil illimitée dès qu'ils rejoignent leur domicile. Les opérateurs cellulaires intéressés à maintenir la loyauté de leurs clients doivent trouver une alternative à ce concurrent. Une des solutions envisagées est le déploiement de femtocell. Une femtocell est une boîte assez similaire en apparence au routeur WiFi classique. La femtocell est reliée au réseau de l'opérateur par le biais de l'accès internet résidentiel haut débit de l'utilisateur. Cette technologie est actuellement testée dans le monde entier par les fabricants et les opérateurs.

Ainsi l'utilisateur se retrouve face à un nouveau dilemme. Quelle technologie choisir. Si il fut une époque où comme nous l'avons mentionné chaque technologie correspondait à un service donné voilà chose qui n'est plus vraie. Il nous faut donc étudier de plus près les capacités de chacune de ces technologies. Si pour certaines technologies filaires de simples calculs peuvent permettre des approximations "grossières", il n'en n'est pas de même pour le sans fil. La ressource radio est par essence une ressource partagée. Ainsi quelque soit le protocole d'accès multiple envisagé, il nous faut prendre en compte les interférences qui pourraient survenir. Par ailleurs même si l'on considère une seule cellule hypothétiquement isolée du reste du monde, il nous faudrait considérer le débit "gaspillé" par le protocole d'accès multiple.

Dans ce travail nous proposons d'évaluer la capacité des deux technolo-

gies mentionnées: le wifi et la femtocell.  
Cependant la difficulté dans l'évaluation des performances pour chacune de ces technologies ne se situe pas au même niveau.

## **Evaluation de la capacité d'une cellule: besoin et défi**

Pour le wifi, le problème majeur consiste à savoir quel est le débit qu'un utilisateur peut espérer obtenir de son point d'accès sans fil. Autrement dit, nous nous concentrons uniquement sur une cellule couverte par un seul point d'accès. Le standard wifi se base sur le mécanisme connu sous le nom de CSMA/CA pour gérer l'accès multiple à une même station de base entre différents utilisateurs. Cette gestion est réalisée de manière distribuée. Chaque utilisateur doit vérifier que le canal est libre durant un certain temps avant de pouvoir transmettre. Si le canal est occupé, l'utilisateur doit attendre à nouveau un temps aléatoire pour pouvoir retenter une transmission. Même après avoir transmis, une collision peut survenir si par exemple deux stations se connectent au même point d'accès et ont "par hasard" attendu le même temps aléatoire. Le caractère stochastique de ce mécanisme d'accès rend difficile la tâche d'évaluation de la capacité effective d'une cellule wifi.

On pourrait argumenter que pour ne pas prendre risque il suffit de surdimensionner le réseau à savoir introduire un grand nombre de points d'accès wifi pour couvrir une surface limitée. Or malheureusement, cette solution certes faisable en filaire peut mener à de sévères interférences entre cellules au niveau sans fil. Par ailleurs dans la mesure où le CSMA/CA est utilisé, le problème de station exposé se posera très rapidement, dans de telles circonstances. Ainsi il est primordial de pouvoir évaluer justement et le plus exactement possible la capacité d'une cellule wifi, afin de pouvoir optimiser l'utilisation de la ressource radio mise à disposition d'un point d'accès.

## **WiFi offrant la Qualité de service**

La gestion des multiples utilisateurs se faisant par un jeu de temps aléatoires, les limitations au niveau qualité de services se sont faites vite ressentir. Ainsi rapidement un amendement au standard WiFi original apparut qui permit d'offrir la possibilité de donner la priorité à certains types de flux comme par exemple des flux destinés à un service de voix etc.. Cependant malheureusement cela nécessita l'introduction d'une différenciation entre les



temps aléatoires d'attente entre chaque flux qui n'a fait que compliquer la tâche d'évaluation de capacité d'une cellule wifi. Par ailleurs de nombreux paramètres au sein du protocole d'accès multiple ont été mis à disposition de l'administrateur réseaux afin de gérer la différenciation entre les services. Cependant devant la complexité du protocole et son caractère aléatoire, il n'est pas possible à première vue de comprendre l'influence de chacun des paramètres sur la capacité effective offerte à chaque service.

## Objectifs et contribution de la thèse

### Modèle stochastique de l'accès à la ressource du WiFi

Ainsi il apparut qu'il fallait trouver rapidement un moyen de modéliser le mécanisme d'accès à la ressource radio du standard wifi. De nombreux modèles apparurent très rapidement, peu après l'apparition du standard wifi. Cependant chaque modèle faisait certaines hypothèses pour des besoins de simplifications. Parmi les hypothèses les plus communes nous retrouvons la saturation du canal, ainsi que son caractère idéal. Un canal saturé consiste à considérer qu'un utilisateur a en permanence un paquet à transmettre ou en d'autres termes que le "buffer" (mémoire tampon) de l'utilisateur n'est jamais vide. Cette hypothèse est souvent justifiée en invoquant le fait que dans le pire des cas, on pourra considérer la modélisation comme un pire cas. Cependant comme nous l'avons mentionné cela mène évidemment à un surdimensionnement qui n'est guère souhaitable. L'hypothèse en elle-même est difficilement justifiable si nous considérons le fait qu'un utilisateur a rarement un paquet à transmettre en permanence. Notamment le trafic d'un utilisateur web qui fait l'objet d'intenses recherches de modélisation se caractérise par des jets discontinus de paquets surnommés "burst" (en anglais) suivi de période de silence généralement du fait que l'utilisateur prend le temps de lire l'information requise.

Une seconde approximation souvent rapportée dans les modèles existants considère le canal comme idéal. Ainsi chaque paquet transmis arrive "sain et sauf" avec une probabilité égale à 1 s'il ne rencontre pas de collision. Or il est bien connu que la ressource radio est bien loin d'être sans erreur. Si dans les réseaux filaires les probabilités d'erreur pour un bit se situent au niveau de  $10^{-16}$  pour les réseaux sans fil cela se situe plutôt aux alentours de  $10^{-8}$  donc près de 1 milliard de fois plus fort. Nous considérons donc à nouveau cette approximation comme trop grossière. Enfin de nombreux modèles ne

considèrent pas le mécanisme d'accès au wifi avec QoS.

Dans cette thèse nous proposons de modéliser le mécanisme d'accès au wifi avec QoS sans faire l'approximation de la saturation ni celle du caractère idéal du canal. Pour cela nous étendons un des plus fameux modèles existant dénommé modèle de Bianchi qui fut lui même étendu par Kong au wifi avec QoS. Grace à notre modèle des résultats plus fiables permettent un dimensionnement plus exact d'une cellule wifi.

## Femtocell

Au niveau femtocell, la difficulté se situe à un autre niveau. En effet les mécanismes d'accès multiples considérés sont suivant la génération: CDMA ou OFDMA. Ces mécanismes n'étant pas aléatoires l'évaluation de la capacité pour une cellule n'est pas réellement un défi. Par contre des qu'il s'agit de prendre en compte les cellules voisines, nous nous trouvons confrontés à de très sévères scenarios d'interférence. Par ailleurs contrairement au wifi, la femtocell doit tenir compte de la cellule macro qui la couvre. En effet les femtocells ne peuvent pas nous soustraire de la nécessité d'une couverture supplémentaire à un niveau plus élevé dans la hiérarchie géographique pour les utilisateurs n'ayant pas la possibilité de se connecter a une femtocell. Des lors se pose le problème de savoir quelle ressource radio la femtocell va t elle utiliser. Une réutilisation du spectre de la macrocell peut paraître alléchante mais va forcément induire de sévères interférences entre femtocell et macrocell. Tandis que l'utilisation d'un spectre consacré n'est pas toujours possible si l'opérateur ne dispose pas de spectre supplémentaire pour cette deuxième couche de station d'accès. Ainsi pour pouvoir évaluer la capacité d'une femtocell, il faut auparavant pouvoir répondre à ce premier défi.

Dans cette thèse nous proposons donc dans un second temps un schéma innovant de réutilisation de fréquences entre macrocell et femtocell. Nous proposons de fusionner les deux approches mentionnées plus haut. A savoir octroyer aux femtocells un spectre dédié qui serait composé de fréquences récupérées des secteurs adjacents de la macrocell. Au moment où nous avons développé cette idée il n'existait pas encore de méthodes de partages de fréquences optimales entre la macrocell et la femtocell. Après avoir octroyé un certain spectre au femtocell nous pouvons alors envisager le calcul de la capacité d'une femtocell. Ce calcul prend en compte les interférences générées par les femtocells voisines réutilisant les mêmes fréquences, ainsi que celles générées par les utilisateurs de la macrocell.

La structure de la thèse est la suivante. Nous proposons dans une première partie de présenter les pré-requis techniques pour une bonne compréhension de la problématique et de la solution. Ensuite nous présentons l'état de l'art détaillé. La problématique du wifi et des femtocells est traitée en parallèle mais dans des chapitres distincts du fait de la spécificité de chacune des problématiques. Nous conservons ce parallélisme jusqu'à la fin de la thèse. Dans une seconde partie nous présentons notre contribution à chacune des problématiques en détails. Enfin dans la troisième partie nous présentons les résultats obtenus à partir de chacune des solutions proposées.

# Partie I: Contexte et Etat de l'art

Dans la première partie de la thèse nous présentons le contexte technique des différentes problématiques traitées tout au long de la thèse suivi de l'état de l'art.

# Chap 2. Le mécanisme d'accès au WiFi et sa modélisation

Dans ce chapitre nous présentons dans un premier temps les différents mécanismes d'accès à la ressource du WiFi, notamment le DCF et le mécanisme EDCA offrant un support de la QoS. Ensuite nous présentons l'état de l'art assez riche de la modélisation de ces mécanismes d'accès.

La norme *IEEE 802.11* est un standard international décrivant les caractéristiques d'un réseau local sans fil (*WLAN*)[1]. Le nom **Wi-Fi** (contraction de *Wireless Fidelity*, parfois notée *WiFi*) correspond initialement au nom donné à la certification délivrée par la Wi-Fi Alliance, anciennement WECA (*Wireless Ethernet Compatibility Alliance*), l'organisme chargé de maintenir l'interopérabilité entre les matériels répondant à la norme 802.11. Par abus de langage (et pour des raisons de marketing) le nom de la norme se confond aujourd'hui avec le nom de la certification. Grâce au Wi-Fi il est possible de créer des réseaux locaux sans fils à haut débit pour peu que la station à connecter ne soit pas trop distante par rapport au point d'accès.

Un réseau local sans-fil a des caractéristiques propres qui rendent difficiles la fourniture d'une qualité de service (QoS) adéquate. Le standard IEEE 802.11 définit deux méthodes d'accès, qui peuvent coexister en s'alternant:

- La Fonction de Coordination Centralisée (PCF - Point Coordination Function), dans laquelle l'accès sans contention est arbitré par le point d'accès. Elle garantit un service à délai borné et est bien adaptée au trafic temps réel, mais elle n'est pas implémentée dans les produits 802.11 actuels.

- La Fonction de Coordination Distribuée (DCF), qui permet un accès

au médium avec contention. Il s'agit donc d'un service de type "au mieux" (best effort).

Le DCF est la fonction principale d'accès au canal du standard 802.11, qui permet de partager le milieu sans fil par le biais du protocole CSMA/CA. Ce mécanisme est obligatoire pour toutes les STA.

La détection de la porteuse se fait par le biais de mécanismes physiques et virtuels. La détection physique signifie qu'avant de tenter n'importe quelle transmission, une STA écoute le canal et vérifie que le milieu sans fil est inoccupé pendant une certaine période. La durée de la période varie, mais la durée usuelle, utilisée avant de tenter de transmettre, est appelée DIFS (*DCF Inter Frame Space*).

Pour éviter la collision entre deux STA transmettant des données simultanément, un algorithme de *backoff* est utilisé. Quand une STA désire émettre et que le milieu sans fil est détecté occupé, elle doit attendre jusqu'à ce que le milieu sans fil soit libre pendant une durée d'au moins DIFS. Ensuite la STA tire un nombre aléatoire dans un ensemble de valeurs discrètes uniformément distribuées, ce nombre étant utilisé pour calculer une période supplémentaire pendant laquelle la STA doit observer le canal libre, avant de retenter la transmission.

L'ensemble de valeurs duquel le nombre aléatoire est tiré, s'étend de 0 à *CW* (*pour Contention Windows ou fenêtre de contention*), qui varie en fonction du nombre de tentatives de retransmissions précédentes. Si le milieu sans fil devient occupé pendant le *backoff*, le temporisateur de temps de *backoff* est suspendu. Il sera repris une fois le milieu à nouveau inoccupé pendant un temps de minimum de DIFS.

Une fois qu'une STA a gagné le droit d'émettre sur le milieu sans fil, elle peut transmettre un paquet. La STA attend alors une période appelée SIFS (*Short Interframe Space*) pour recevoir de la part du destinataire un accusé réception (ACK pour *acknowledgement* en anglais) indiquant la bonne réception des données et surtout leur fiabilité. SIFS est plus court qu'un DIFS, ce qui confère à la trame transportant le message d'ACK la plus haute priorité pour accéder au milieu sans fil. Ceci assure qu'aucune autre STA ne commencera la transmission tant qu'un ACK est attendu. Si l'ACK n'est pas reçu après un SIFS, une retransmission est programmée jusqu'à ce que la tentative réussisse ou que le nombre de retransmissions dépasse un certain seuil ou enfin, dans certains cas, que la durée de vie du MSDU expire. Dans ces cas, le MSDU est rejeté.

L'EDCA se veut être une amélioration du mécanisme DCF du standard 802.11x.

L'EDCA comprend 8 priorités différentes organisées en 4 AC. Chaque ACi possède sa propre file d'attente et ses propres caractéristiques à savoir : son propre temps d'attente AIFS[i] (Arbitrary Inter-Frame Space anciennement DIFS), CWmin[i], CWmax[i]. Ces valeurs sont paramétrées de telle sorte que pour  $0 < i < j < 3$  les valeurs de j soient toujours inférieures à celles de i. De cette manière l'AC de plus haut indice aura intrinsèquement (grâce à des temps plus petits) plus de chances d'accéder au canal.

Par ailleurs, les valeurs des AIFS, CW etc. de chaque AC qui sont considérées comme les "paramètres EDCA", sont annoncées par le QAP (QoS Access Point) par le biais des trames BEACON transmises périodiquement. Le QAP peut adapter ces paramètres en fonction de l'état du trafic dans le réseau. Dans certains cas, par exemple lorsque le réseau est chargé, il est même nécessaire de faire varier ces paramètres. Cependant l'algorithme de réglage des paramètres n'est pas fourni par le standard, et est laissé à la discrétion des constructeurs. En général, la variation des paramètres s'inscrit dans le cadre d'une politique de contrôle d'admission.

Ainsi, si l'unité de contrôle d'admission décide de ne plus accepter de flux de données ou du moins de diminuer ces flux, elle peut faire augmenter les paramètres EDCA de l'AC des data.

Devant l'engouement grandissant du marché face aux technologies d'accès à Internet par le biais de réseaux sans fils, le déploiement de ces réseaux constitue désormais un enjeu de taille. En effet, jusqu'à présent, le déploiement se fait de manière quasi empirique, i.e., dès que la qualité de la transmission n'est pas satisfaisante pour l'utilisateur final, on rajoute, un point d'accès. Cette technique de surdéploiement, présente de nombreux inconvénients. Tout d'abord, elle entraîne, de fortes interférences, entre les différentes cellules couvertes par des points d'accès différents, appelées aussi interférence cocanal (ou en anglais le problème du *cochannel overlap*). De plus, cette solution reste coûteuse. Il faut donc optimiser, le nombre d'utilisateurs d'une cellule en maintenant une qualité de transmission raisonnable, liés avec les contraintes de Qualité de service des diverses applications requises.

Depuis l'avènement des premiers Standards 802.11 en 1997 [1], les laboratoires de recherche n'ont cessé d'essayer de modéliser le comportement des mécanismes d'accès à la ressource de ces standards.

En effet, le principal mécanisme d'accès du standard 802.11 qu'est le DCF est difficile à modéliser [1]. Il comporte de nombreux paramètres qui évoluent au cours de la tentative de transmission des paquets par une STA. Or, un bon modèle constituerait la clé d'un futur outil de dimensionnement des réseaux sans fils. En effet, actuellement, le déploiement d'infrastructures

WI-Fi se fait de manière quasi empirique. Il n'existe pas à l'heure actuelle de logiciel capable de fournir comme données, combien d'ordinateurs peuvent être reliés à un même hot spot, en fonction du profil de l'utilisateur. Un modèle précis pourrait expliciter le débit offert par une cellule, ainsi que le délai d'attente minimale avant qu'une transmission réussisse. Avec ces données, le dimensionnement et l'optimisation des réseaux deviennent réalisables.

Pour ce, il faut arriver à calculer la probabilité de collision, d'erreurs sur le canal, le temps moyen passé en période de contention avec les autres STA. Ces événements étant par nature aléatoires, le modèle ne pourra qu'au mieux tendre vers la réalité mais ne constituera en aucun cas un modèle exact.

De nombreux modèles ont déjà vu le jour, chacun ayant sa spécificité et ses approximations propres, puisque comme nous l'avons dit précédemment, il est impossible de refléter exactement le comportement réel du système.

On compte deux principaux modèles. Dès 1996, Bianchi *et al.* [17] s'intéressent aux mécanismes de CSMA/CA utilisés par le DCF et à ses performances. En 1998, il publie son modèle [15]-[16], basé sur les chaînes de Markov. Bianchi obtient le débit maximal accessible en régime saturé grâce à son modèle i.e., les stations ont toujours un paquet à émettre. En parallèle, Cali *et al* [18] développent leur propre modèle basé sur le principe des distributions géométriques (à l'instar de Bianchi).

Les approximations clés du modèle de Bianchi sont les suivantes :

- la probabilité qu'une Sta émette dans un time slots donné est constante
- la probabilité qu'une station rencontre une collision est constante et indépendante, du nombre de collisions déjà rencontré.

Par ailleurs, le canal est supposé idéal, i.e., n'introduisant pas d'erreur dans les paquets, le nombre limite de retransmissions défini dans le standard n'est pas pris en compte dans le modèle. Le problème des stations à débits dégradés et des stations cachées n'est pas non plus pris en compte. Enfin, aucun délai n'a été calculé.

Le modèle de Cali et al. permet aussi de calculer le débit maximal offert en régime saturé. Cependant, ils supposent que modéliser précisément le processus de Backoff est quasiment impossible. De ce fait, les paramètres apparaissant dans la formule du débit, tel que le temps de backoff moyen ainsi que le temps moyen passé en période de collision, sont calculés de



manière approchée. Le nombre moyen de collisions étant calculé en fonction de la probabilité de collisions, cette dernière est obtenue en considérant que cette probabilité correspond au paramètre de la distribution géométrique qui permet d'obtenir la valeur des temps de backoff moyen de chaque étape. Chaque temps de backoff d'une étape donnée étant approximé à la moitié de la fenêtre de contention de cette étape.

Afin d'améliorer ces 2 modèles déjà existants, plusieurs articles ont été publiés pour essayer d'améliorer l'une des approximations sur laquelle les deux précédents modèles ont été construits.

Notre article se place dans le contexte d' IEEE 802.11e. Nous reprenons en partie les travaux de [48]. Notre travail est une amélioration des modèles IEEE 802.11 ainsi que des modèles IEEE 802.11e existants. En effet, notre objectif est de synthétiser l'ensemble des modèles pour fournir un modèle plus robuste et complet. Ainsi, nous proposons une amélioration d'une part du point de vue du support physique puisque nous représentons le comportement du système dans un environnement non idéal, (i.e., qui introduit des erreurs dans les paquets), d'autre part, nous prenons en compte le fait que les stations n'ont pas toujours un paquet à émettre (i.e., le buffer d'émission de la carte réseau peut être à un instant donné, vide). Ces objectifs sont motivés par le fait que l'hypothèse d'un canal idéal est (comme dans de nombreux modèles cités) une simplification assez grossière dans le domaine du sans fil. De plus l'accès au débit maximal en régime saturé ne permet pas de dimensionner le réseau, mais permet uniquement de fournir un pire cas. Comme nous le verrons plus loin, notre modèle permet d'accéder à des valeurs maximales de débit et de délais plus pertinentes.

## Chap 3. Allocation de fréquences aux Femtocells

Alors que le déploiement des réseaux cellulaires de troisième génération (3G) commence à gagner du terrain, les réseaux au-delà de la 3G ou 3.5G apparaissent déjà à l'horizon. Malgré ces avancées technologiques qui offriront de meilleurs services aux utilisateurs, les problèmes de couverture ainsi que le débit offert aux utilisateurs persistent. Ces problèmes deviennent critiques dès qu'il s'agit de couvrir un utilisateur localisé à l'intérieur d'un bâtiment.

En effet l'atténuation résultant des divers matériaux entraînent une dégradation importante du rapport signal à bruit (RSB). Or la couverture en intérieur est un paramètre fondamental pour un opérateur de réseaux cellulaires dans la mesure où des études montrent qu'un très fort pourcentage des utilisateurs de téléphones mobiles se trouve en intérieur. Le manque de réelle solution à ces problèmes a poussé les utilisateurs à trouver des moyens alternatifs de communication à l'intérieur mais toujours avec le téléphone mobile.

Pour faire face à cette situation, une idée proposée déjà il y a plus de dix ans revit le jour. Elle consiste tout simplement à réutiliser l'accès internet à haut débit déjà disponible chez l'utilisateur tout comme le Wifi. Pour cela l'utilisateur doit acquérir un boîtier de la taille d'un routeur wifi, et le brancher à sa connexion internet. Ce boîtier est surnommé "Femtocell" ou "station de base résidentielle". Dès qu'il pénètre dans sa maison, la femtocell détecte et établit le contact avec le téléphone cellulaire. Désormais toutes les communications initiées à partir du téléphone mobile sont véhiculées par la femtocell via la connexion internet.

Cette solution présente de multiples avantages économiques et techniques évidents du point de vue opérateur mais aussi utilisateur. Pour l'opérateur, la fidélité du client est assurée même en intérieur. Par ailleurs l'utilisateur en intérieur possédant une femtocell déchargera la station de base de l'opérateur

surnommée Macrocell qui assure la couverture globale du voisinage. Ainsi la Macrocell pourra mieux servir les utilisateurs à l'extérieur en supportant un plus grand nombre d'utilisateurs ou en proposant un meilleur débit aux utilisateurs existants.

Du point de vue utilisateur les bénéfices sont incontestables. Tout d'abord la couverture personnelle désormais assurée offre une puissance de signal qui protège de potentiels désagréments lors d'un appel. De plus, un débit plus important est disponible permettant de tirer enfin profit des différents services offerts par les nouvelles générations de technologies des réseaux cellulaires ex. le téléchargement d'une vidéo etc...

Enfin d'un point de vue économique, l'utilisateur pourrait jouir d'une tarification préférentielle lorsqu'il communique à partir de sa station de base personnelle, dans la mesure où il allège le trafic supporté par la Macrocell le surplombant. Par ailleurs, il ne sera désormais plus nécessaire d'acquérir un téléphone dual-mode puisque que la technologie de base des femtocell sera parfaitement compatible avec les téléphones cellulaires classiques déjà existants.

Cependant comme toutes bonnes choses, cette solution présente de nombreux défis. L'enjeu majeur consiste à savoir comment la femtocell pourra coexister avec la Macrocell "mère", à savoir celle qui assure la couverture du voisinage y compris celle des utilisateurs en intérieur ne possédant pas "encore" de femtocell. A ce niveau, il convient de distinguer entre les différentes technologies de transmission sur les réseaux cellulaires existants ou à venir. En effet l'approche du problème n'est pas identique qu'il s'agisse de la troisième génération (3G) ou de la quatrième génération (4G). Quelque soit la génération considérée, il nous faut étudier les interférences générées par la femtocell, tant sur la Macrocell "mère" que sur les femtocell attenantes. Ce problème se situant au niveau de la couche physique constitue l'appréhension majeure des opérateurs et sa bonne résolution est la condition sinequanone au développement futur de cette technologie prometteuse.

Dans ce chapitre nous présentons les différents types d'accès au femtocell: l'accès "ouvert" à tous les utilisateurs et l'accès réservé uniquement aux propriétaires du matériel. Nous présentons ensuite le défi majeur que représente les interférences entre les femtocells elles-mêmes puis entre femtocells et macrocell.

Ensuite nous présentons un historique des femtocells qui ont déjà été proposées dans la fin des années 80 dans le contexte du GSM. Enfin nous proposons de nous focaliser sur le défi physique majeur : le problème de l'allocation de ressources aux femtocell et la gestion des interférences induites par chaque type d'allocation. Nous présentons les différents travaux déjà

publiés dans ce domaine, notamment dans le contexte de la gestion des ressources radio pour la 4<sup>ème</sup> génération des réseaux cellulaires.

## Partie II : Les solutions proposées

## Chap 4. Modèle EDCA non saturé en présence d'erreurs

La chaîne de Markov représentée ci-dessous, correspond à la modélisation du comportement d'une AC pour une STA gérée par le mécanisme. Dans le cas d'une modélisation du DCF et non de l'EDCA, il suffirait dans notre modèle de considérer cette chaîne comme une STA, moyennant quelques modifications dans les formules à venir, le principe restant exactement le même.

Nous avons introduit pour les besoins de notre modèle une 4ème dimension,  $e(t)$ . Cette variable binaire, indique par sa valeur à 1, lorsque la transmission n'a pas subi de collision mais ne connaît pas de succès car la transmission est erronée.

Cette variable a été introduite afin de faire la différence entre, une transmission échouée en raison d'une collision et celle qui échoue en raison d'une erreur. On ne trouve pas cette dimension dans les modèles précédents puisque le canal est pour la grande majorité des modèles, supposé idéal. Dans tous les autres états  $e(t) = 0$ .

Soit  $p_i$  la probabilité de collision et  $p_b$  la probabilité que le canal soit occupé. Nous supposons comme [43] que ces probabilités sont indépendantes de la procédure de backoff. Par ailleurs, la probabilité  $p_i$ , est constituée de deux parties : une probabilité de collision externe due aux transmissions des autres STA et une probabilité de collision interne, due à la contention virtuelle qui a lieu entre les ACi d'une même STA.

A l'instant  $t$ , on peut considérer que l'état d'une AC est entièrement déterminé par le quadruplet  $(j,k,d,e)$  qui correspond aux valeurs prises respectivement par chacune des dimensions.

Supposons que l'AC se trouve à l'état  $(j, 1, 0, 0)$ . L'AC a donc rencontré  $j$  collisions et/ou transmissions erronées et subit son  $j$ ème backoff pour tenter une retransmission du paquet en cours. Cela est indiqué par la pre-

mière dimension de cet état. Son compteur de temps de backoff est égal à 1 (Comme indiqué par la deuxième dimension de l'état) et en cours de décrémentation, i.e., le compteur n'est pas suspendu, comme l'indique la valeur de la troisième dimension à 0. Par ailleurs, sachant que la jième transmission n'a pas encore débuté, la 4ème dimension est par défaut égale à 0.

Nous décrivons ensuite en détails les probabilités de transition d'un état à un autre dans notre modèle. Puis nous calculons les probabilités en régime établi.

Posons  $b_{j,k,d,e}$  la probabilité d'être à l'état  $(j,k,d,e)$ , lorsque le système est en régime établi ou stable autrement dit lorsque  $t \rightarrow \infty$ . Nous exprimons l'ensemble des probabilités en régime établi en fonction de la probabilité  $b_{0,0,0,0}$ . Toutes les probabilités  $b_{j,k,d,e}$  peuvent être exprimées en fonction de  $p_{bi}$ , la probabilité que le canal soit occupé,  $p_i$ , la probabilité de collision de ACi,  $p_e$ , le taux d'erreur par paquet reçu,  $q$ , la probabilité d'avoir un paquet en attente dans le "buffer" .

On détermine finalement  $b_{0,0,0,0}$  en imposant la condition de normalisation suivante, à savoir que l'AC ne peut se trouver que dans un des états de la chaîne de Markov, ainsi la probabilité de se trouver dans un de ces états est égal à 1, d'où:

$$\frac{1}{b_{0,0,0,0}} = \left[ \begin{array}{l} \frac{1-q}{q} + [Ts](1 - (P_{fi})^{m+h+1}) \\ + (1-q) \left( \frac{1-(1-P_b)^{A_i+1}}{P_b} \right) \\ + \frac{1-(1-P_b)^{A_i+1}}{P_b} \left[ \frac{1}{(1-P_b)^{A_i+1}} - (1-q) \right] + N \frac{1-(1-P_b)^{A_i+1}}{(1-P_b)^{A_i+1}} \\ + ([Tc]P_i + 1) \left( \frac{1-P_{fi}^{m+h}}{1-P_{fi}} \right) \\ + ([Te](1-P_i)P_e) \left( \frac{1-P_{fi}^{m+h}}{1-P_{fi}} \right) \\ + \frac{1+NP_b}{2(1-P_b)^{A_i}} \left( \left[ 1 - (1-q)(1-P_b)^{A_i+1} \right] \times W_0 \right) \\ + \sum_{j=1}^{m+h} W_j P_{fi}^j + P_{fi}^{m+h} \end{array} \right]$$

Ainsi, pour calculer  $b_{0,0,0,0}$  il faut avoir accès aux valeurs de Ts, Tc, Te,  $p_b$ ,  $p_i$ ,  $p_e$ , m, h,  $W_j$ , A, N, et q qui sont tous définis par la suite.

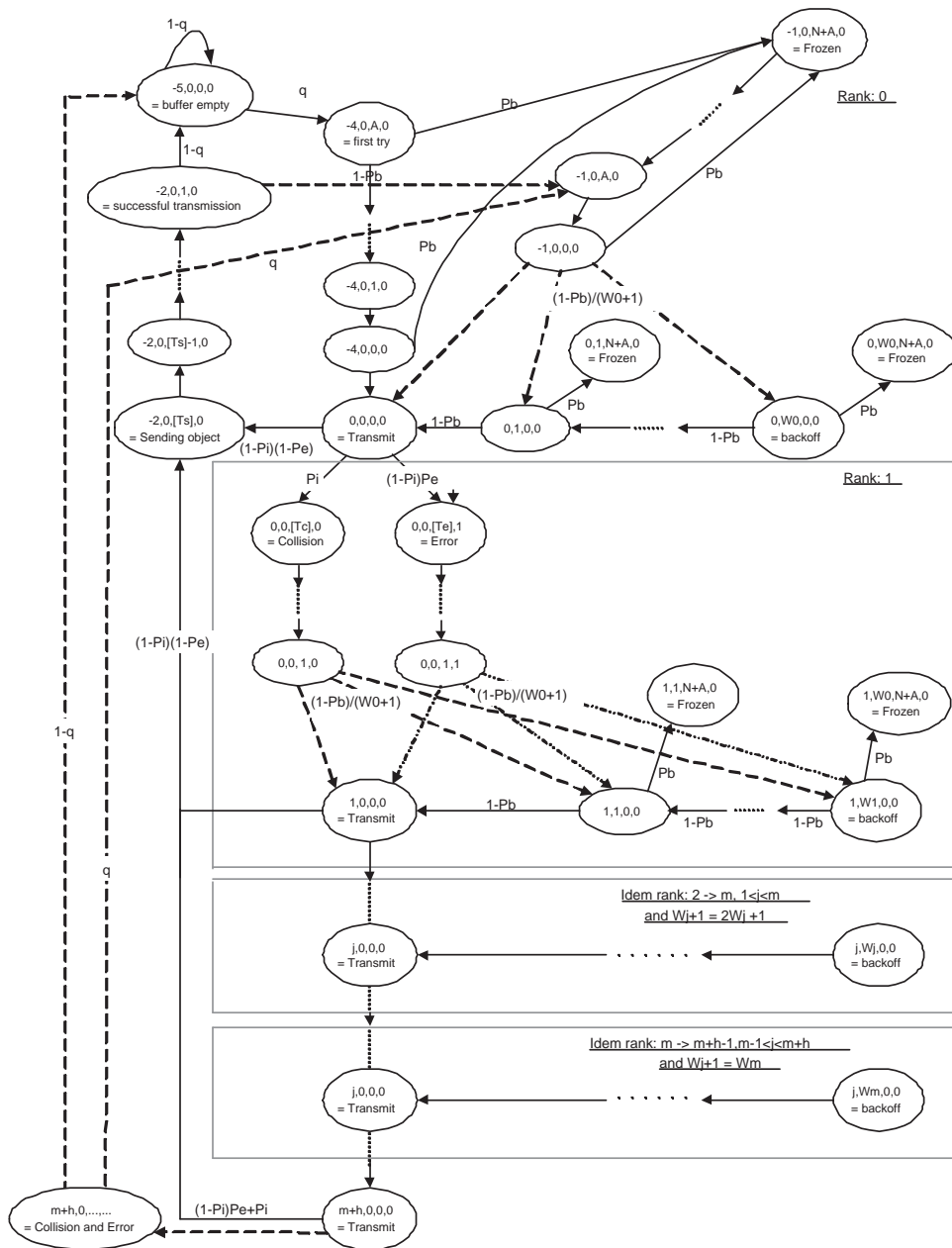

La chaîne de Markov entière



# CHAP. 5 Double réutilisation de fréquences entre macrocell et femtocell

Dans ce chapitre nous présentons le schéma d'allocations de fréquences que nous proposons pour gérer les interférences entre macrocell et femtocells. Il existe de manière générale deux approches de partages des ressources. La première consiste à attribuer à chaque couche à savoir macrocell et femtocell un set de fréquences dédiées. En assurant un partage orthogonal des fréquences on s'assure ainsi de ne pas rencontrer des problèmes d'interférences entre les deux couches. Cependant cette solution ne permet pas une utilisation efficace de la ressource.

Une autre approche consiste à offrir à la seconde couche la possibilité de réutiliser la ressource déjà utilisée par les macrocell. Cette solution certes optimale induit de fortes interférences co-canal.

Nous proposons un schéma de réutilisation de fréquences qui tire profit à la fois de la réutilisation des fréquences et de l'orthogonalité entre les macrocells et femtocells.

Pour cela nous nous plaçons dans le contexte des technologies basées sur l'OFDMA. Nous proposons que chaque femtocell se trouvant dans un secteur donné réutilise les fréquences utilisées par les secteurs adjacents.

Afin d'affiner ce schéma de réutilisation de fréquences nous proposons trois variantes d'allocations de fréquences suivant la localisation de l'appareil par rapport à la position de la station de base macrocell. Nous rappelons tout d'abord que l'on considère ici un spectre de fréquences divisé en trois groupes de canaux

La première variante surnommée "full reuse" (réutilisation pleine) consiste à offrir aux femtocells se trouvant dans un secteur donné l'ensemble des canaux des deux autres secteurs adjacents couverts par la station de base

macrocell.

La seconde variante surnommée "partial reuse" (réutilisation partielle) considère un partage de chaque secteur en six zones triangulaires. Les femtocells se trouvant dans chacun des triangles ne peuvent réutiliser que la partie du spectre de fréquences qui n'est pas utilisé par le secteur de la macrocell lui faisant face. Autrement dit, des trois groupes de fréquences précédemment définis, uniquement un seul d'entre eux est mis à disposition des femtocells se trouvant dans un triangle donné. L'avantage de ce mode d'allocation est que les femtocells se trouvant dans un triangle ne souffrent pas d'interférence provenant du secteur faisant face au triangle. L'inconvénient est que le set de canaux disponibles pour les femtocells d'un triangle est réduit, ce qui va forcément augmenter les interférences co-canal entre les femtocells du même triangle.

Enfin considérant que les interférences entre les femtocells mentionnées juste avant dans le cas du "partial reuse" pourraient être assez importantes, nous avons proposé une troisième variante. Dans ce mode surnommé "mixed reuse" (réutilisation mixte) nous distinguons dans chaque secteur deux régions: la région qui borde de manière circulaire l'ensemble du secteur surnommé "bord" et la région au centre du secteur. La région bord est à nouveau sous divisée en zone de façon identique à la méthode "partial reuse".

La logique sous jacente à ce partage est la suivante. Comme mentionné dans le cas partial reuse, les femtocells qui bordent le secteur souffrent d'interférences co-canal sévères si elles réutilisent les mêmes fréquences que les secteurs qui leur font face. Mais d'un autre côté, restreindre les femtocells au mode partial nous oblige à faire face à des scénarios d'interférences entre femtocells. Ainsi comme compromis nous définissons la région bord où les femtocells ne peuvent pas réutiliser les canaux utilisés par les secteurs leur faisant face. Dans la région centre le schéma full reuse est appliqué. Ainsi nous "mixons" les deux approches précédentes.

## Partie III : Les résultats

# CHAP. 6 Calcul des performances du modèle de l'EDCA

Les performances d'un système ne peuvent se résumer à une probabilité de collision. En effet, quelle utilité ces informations pourraient avoir pour un utilisateur ou un opérateur?. Les informations réellement intéressantes du point de vue de l'utilisateur correspondent aux paramètres influant sur la QoS.

Le débit normalisé pour une AC donnée est calculé comme le rapport entre le temps utile pour émettre les données et le temps moyen entre deux transmissions successives. Ce temps moyen prend en compte le temps d'attente en procédure de contention, le temps éventuellement perdu en collision et/ou erreur ainsi que le temps pour émettre avec succès le paquet, incluant les différents temps d'émission des en-têtes.

Le débit  $S_i$  s'exprime alors de la manière suivante :

$$S_i = \frac{P_{si}P}{E[I] + \sum_{i'=0}^3 P_{si'}(T_s + AIFS[AC_{i'}]) + \sum_{i'=0}^3 P_{i'}T_c + P_eT_e}$$

Où  $E[P]$  correspond à la taille des données utiles d'un paquet moyen. En général cette donnée est fixée pour faciliter le calcul. Cependant en pratique, selon l'application modélisée, cela peut s'avérer inexact. Par exemple en conversation VoIP, la taille des paquets est constante et est choisie en fonction de la qualité, du délai et du codec utilisés. Par contre, pour une modélisation d'une application telle que l'affichage de pages web, la taille des paquets suit une loi assez difficile à caractériser. De nombreuses recherches ont été effectuées dans ce domaine, mais aucun résultat précis, n'a pu encore modéliser correctement l'évolution de la taille des paquets pour une session

web. En tout état de cause, on peut par exemple prendre une loi de poisson. La manière de calculer  $E[P]$  est inspirée de [16].

$E[I]$  désigne la valeur moyenne de time slots, inutilisés, autrement dit de time slot, où le canal est libre. Cette valeur reflète les temps de backoff.

On a :  $E[I] = \frac{1}{p_b} - 1$

Cette formule s'obtient en considérant une distribution géométrique de paramètre  $p_b$ , le temps entre 2 intervalles inutilisés (idle time slot) étant obtenu par la formule ci-dessus.

$p_{si}$  et  $p_{si'}$  correspondent aux probabilités que la transmission aboutisse avec succès, pour resp. ACi et ACi'.

La formule permettant d'obtenir  $p_{si}$  est la suivante :

$$p_{si} = \frac{M p_{ti} (1 - \tau)^{M-1} \prod_{i' > i} (1 - \tau_{i'})}{1 - (1 - \tau)^M}$$

avec

$$p_{ti} = T_s * (\vec{b})_i * (1 - (p(\vec{\tau})_i)^{m+h})$$

Pour les notations utilisées dans la formule de  $p_{ti}$ , se référer plus loin à la résolution mathématique de notre problème.

Pour le calcul des temps  $T_s$ ,  $T_c$ , et  $T_e$ , nous avons utilisé en général les données du standard.

Le calcul du délai se fait de la manière suivante. Posons  $D_{j,k,d,e}$  l'intervalle de temps représentant le délai entre le moment où le système est à l'état (j,k,d,e) et le moment où le paquet est transmis avec succès. Le délai total pour un paquet transmis avec succès correspond à l'intervalle de temps entre le moment où le paquet se trouve dans la file d'attente Mac, prêt à être transmis, jusqu'au moment où la trame d'acquiescement pour le paquet concerné est reçu par l'expéditeur. Après avoir effectué de nombreux calculs on obtient  $D$  le délai moyen qu'un paquet devra attendre, comme défini précédemment :

$$D = \sum_{d=0}^{N+A} b_{-1,0,d,0} D_{-1,0,d} + \sum_{j=0}^{M+h} \sum_{d=0}^{[T_c]} b_{j,0,d,0} D_{j,0,d,0} \\ + \sum_{j=0}^{m+h} \sum_{d=0}^{[T_c]} b_{j,0,d,0} D_{j,0,d,0} + \sum_{j=0}^{m+h} \sum_{k=0}^{W_i} \sum_{d=0}^{N+A} b_{j,k,d} D_{j,k,d,0}$$

# CHAP. 7 Performances des femtocell

Dans ce chapitre nous cherchons à déterminer qu'elle serait la valeur ajoutée des femtocells si elles étaient introduites par un opérateur dans son système.

Pour ce, nous utilisons deux métriques classiques qui sont le rapport signal à Interférence plus bruit (RSB) et la puissance du signal.

Pour évaluer les performances selon ces métriques il a fallu tout d'abord envisager un système permettant d'obtenir des résultats. Pour les besoins de la thèse nous avons donc développé un simulateur du système. Nous présentons dans ce chapitre les différentes interfaces du simulateur ainsi que la manière dont les résultats sont présentés.

Par la suite nous présentons une série de résultats de performances des femtocells.

Nous étudions tout d'abord le gain en puissance du signal reçue en comparant le cas d'un utilisateur relié à sa propre femtocell et le cas où ce même utilisateur est connecté à la macrocell. Nous montrons que les performances de la femtocell sont supérieures à celles de la macrocell dans tout les cas même en supposant que la macrocell transmet à une puissance supérieure de 30 dB à la puissance d'émission de la macrocell. Cela correspond au sens "descendant". Les différences dans le sens montant sont encore plus aigues puisque le téléphone cellulaire est fortement limité en termes de puissances d'émission indépendamment de la station avec laquelle il est connecté que ce soit une macrocell ou femtocell.

En parallèle nous présentons toutes une séries de résultats de rapport signal à Interférence plus Bruit. Cette dernière métrique est plus significative car elle prend en compte les interférences. Ainsi nous pouvons comparer les diverses variantes proposées.

Nous montrons tout d'abord que de manière générale le mode de pleine

réutilisation des fréquences donne les meilleurs résultats. Ce qui s'explique aisément en prenant en ligne de compte les interférences entre femtocells. Dans ce mode un plus grand nombre de canaux sont mis à disposition des femtocells.

Pour pouvoir comprendre les limites des différents modes proposés nous avons étudié les performances obtenues dans des cas plus spécifiques. Nous avons défini trois types de déploiements des femtocells: un déploiement uniforme sur toute la surface du secteur, un déploiement aux bords du secteur et enfin un déploiement où les stations sont aux centres du secteur. A notre grande surprise, nous avons découvert que même lorsque les stations sont situées aux bords le mode de pleine réutilisation donne les meilleurs résultats. Nous en avons déduit que les interférences entre femtocells étaient bien plus significatives que celles engendrées par les macrocell adjacentes.

# Conclusion

Après le succès inattendu des réseaux cellulaires de 2<sup>ème</sup> génération (2G) qui ont donné la possibilité aux utilisateurs mobiles situés en dehors de leur domicile de profiter de services de téléphonie lors de leur séjour en extérieur, et le déploiement croissant de réseaux locaux sans fil à domicile, nous observons une hausse permanente de la demande en Internet mobile à haut débit pour les utilisateurs situés en intérieur.

.Dans cette thèse nous nous sommes intéressés à deux technologies qui peuvent être définies comme des réseaux locaux sans fil: la technologie surnommée WiFi, et la nouvelle technologie femtocell. L'objectif de cette thèse était d'évaluer pour chacune de ces technologies séparément le facteur limitant la possibilité d'offrir de hautes performances en termes de débits aux utilisateurs.

Au niveau du WiFi, ce qui peut être considéré comme le goulot d'étranglement de la performance est le mécanisme d'accès multiples à la ressource radio par plusieurs utilisateurs. En fait, même si le mécanisme CSMA / CA est un bon compromis par rapport aux autres mécanismes d'accès tels que TDMA, CDMA, etc ... notamment parce qu'il est distribué, il requiert tout de même un ensemble de temps d'attente qui entraîne un " gaspillage " de la ressource radio. Le défi consistait à évaluer les performances de ce mécanisme dans les conditions les plus proches de la réalité en termes de débit et de délai. En raison de la nature stochastique de ce mécanisme, les modèles théoriques sont naturellement souvent utilisés afin de décrire le fonctionnement du mécanisme. Plusieurs modèles ont déjà été développés, mais ils sont tous basés sur de simples suppositions. La plupart des hypothèses communes sont entre autre celle d'un canal idéal n'introduisant aucune erreur, et celle du régime sature .... En outre les modèles existants ne considèrent pas le mécanisme de la couche MAC du WiFi qui offre une différenciation des services autrement dit le support de la qualité de service (en anglais QoS: Quality Of Service).

Dans la première partie de cette thèse nous avons développé un modèle précis du mécanisme EDCA se basant sur une chaîne de Markov à quatre



dimensions. Ce modèle est une extension du modèle de Kong et al, lui même basé sur le modèle original de Bianchi. Nous avons modifié ce modèle pour y inclure un canal non idéal où des erreurs peuvent se produire avec une probabilité fixe. Nous considérons également différents scénarios de trafic: saturés ou non saturés avec des charges de trafic variables. Grâce à notre modèle, nous avons pu analyser l'effet des différents paramètres du mécanisme EDCA sur le débit tels que la fenêtre de contention "Contention Window" ou les temps d'attentes entre trame AIFS qui permettent de différencier les utilisateurs. Nous montrons que ces paramètres offrent une bonne différenciation entre les catégories d'accès des différents services. Nous montrons aussi les délais subis par les utilisateurs pour chaque catégorie d'accès. Nous observons que le facteur  $q$  de non-saturation a un effet non négligeable sur le délai ce qui confirme à nouveau l'importance d'un modèle non saturé du réseau. Ainsi, notre modèle est très riche, ce qui le rend plus précis et plus proche de la réalité, mais qui nécessite des calculs plus complexes. Le résultat principal du modèle consiste en calcul du débit qui conduit à l'évaluation de la capacité du système. Ce résultat est essentiel pour concevoir un outil de déploiement de réseaux de type WiFi. Notre non-modèle non-saturé permet d'éviter un surdimensionnement qui conduirait à de fortes interférences entre différents points d'accès étant donné le nombre restreint de canaux utilisables dans cette technologie. Dans la deuxième partie de cette thèse, nous avons évalué les performances des femtocell. Nous avons d'abord présenté les défis et les opportunités de cette nouvelle technologie. Ensuite, nous nous sommes focalisés sur le principal facteur limitant la performance à savoir les interférences co-canal.

Ce défi est directement lié à la façon dont nous allouons les ressources radio à ce réseau seconde couche. D'un côté si nous divisons le spectre commun partagé entre les macrocells et la couche femtocell en deux spectres disjoints nous bénéficions d'une protection contre les interférences co-canal. Cependant l'efficacité du spectre est perdue. D'un autre côté si nous laissons aux deux couches la possibilité de partager le spectre nous sommes confrontés à un scénario de fortes interférences .

Dans un premier temps nous avons présenté un schéma d'allocation des ressources radio déjà existant. Nous avons constaté que beaucoup de méthodes déjà existantes depuis longtemps ont été déjà proposées au moment où les Femtocell ont été envisagés pour les technologies de deuxième génération (2G) comme par exemple le GSM. Toutefois, le concept de femtocell n'avait pas été sérieusement considéré à ce moment.

Ensuite, nous avons proposé un nouveau schéma de réutilisation des fréquences qui permet de mélanger les deux approches mentionnées, à savoir le fraction-

nement du spectre et le partage du spectre. Afin d'accroître l'efficacité de l'utilisation de la ressource radio, nous avons proposé de réutiliser les canaux alloués au secteur voisin de la macrocell se superposant actuellement à la femtocell. Trois formes de réutilisation différentes ont été proposées, chacune adaptée à un scénario spécifique. Nous avons fondé notre système de répartition sur des systèmes déjà existants, mais qui ont été proposés dans le cadre de Microcell ou d'autres technologies. Nous avons supposé que la technologie sous-jacente est basée sur l'OFDMA qui permet de diviser le spectre. Ainsi, notre système ne peut pas être appliqué au réseau 3G, si l'opérateur ne possède qu'une seule bande de fréquences. Dans le cadre de cette thèse nous avons développé un simulateur statique du système qui nous permet d'obtenir les performances réalisées par les femtocell lorsque notre système de répartition est utilisé. Les métriques utilisés furent le RSS (puissance du signal reçu) et SINR (rapport de signal à interférence et bruit). Nous montrons que femtocell surpasse en termes de performances les macrocells dans toutes les configurations, même lorsque la macrocell transmet à une puissance relativement élevée.

En conclusion, peut-on répondre à la question: quelle est la meilleure technologie?. Malheureusement nous ne sommes pas en mesure de déclarer le vainqueur. Tout d'abord peut-être qu'il n'y a pas de gagnant. Parce que chaque technologie offre une qualité de service différent selon qu'il s'agisse de services donnés ou de voix.

Mais pour être en mesure d'examiner la meilleure technologie, même pour un service donné, nous avons à faire face à des problèmes supplémentaires. Par exemple, nous devons considérer les performances bout à bout. En effet, tant les femtocells que le WiFi sont rattachées aux réseaux de l'opérateur par le biais de la connexion à large bande fixe de l'utilisateur par exemple l'ADSL.

Cependant la différence est que pour la femtocell, une fois la passerelle (Gateway) de l'opérateur atteint, une ressource dédiée est utilisée tandis que les paquets WiFi sont acheminés par le réseau internet classique avec tous les délais que cela induit tels : les congestions de reseaux etc. . . .

Ainsi, certes le WiFi peut offrir des débits plus élevés, surtout si l'on considère l'émergence du standard 802.11 "n". Mais le délai requis peut ne pas convenir pour des applications sensibles aux retards tels que les applications de téléphonie. En outre, certains avantages doivent être traduits directement en termes de performance. Par exemple, l'un des principaux avantages de la femtocell est qu'elle permet l'utilisation du même téléphone mobile déjà acheté, alors qu'un appareil surnomme "dual-mode" est nécessaire si nous voulons que notre téléphone mobile se connecte aux réseaux

wifi. C'est pourquoi une étude approfondie qui inclurait des paramètres économiques serait nécessaire. Il faudrait aussi prendre en compte pour les femtocells les économies réalisées par l'opérateur et l'utilisateur.

# Chapter 1

## Introduction

### 1.1 "Ubiquitous Wireless"

Introduction of smartphones (Blackberry, iPhone and more recently the iPad), lead us to a new era where data is accessible "anywhere", and "anytime". More than 10 years after the extraordinary success of the wired internet, we are experiencing a new explosion of wireless internet which is the logical continuation of the new needs created by the Internet. The possibilities offered by the Internet in terms of communications (Skype, ICQ, Gmail, ...), information (Wikipedia, ...), exchange (e-commerce, ...) and others has become "too" ever-present in our daily lives to be confined to a wire that can be plugged in only certain places. But the appeal of wireless is not without challenges. Wireless communications is inherently different than wireline with many physical impairments that apply only to wireless channels. Despite these, the appeal of wireless is so great that shortly after the appearance of wired data networks in the 60s (ARPANET etc. ..), protocols designed for wireless networks were considered (ALOHA by N. Abramson in 1970 [9]). It is nearly 25 years since the first mobile phone appeared. In those early years of wireless the primary use considered was voice service. Short messaging service "SMS" included in the first Global System for Mobile communication (GSM) standard from the early 90's experienced a success well beyond the expectation of its designers. Then, there was the evolution to wireless data services with General Packet Radio Service (GPRS), Universal Mobile Telecommunication System (UMTS) and High Speed Packet Access (HSPA). Accessibility to broadband data services from a fixed terminal took off with the emergence of the Wireless Fidelity (WiFi) standard in 1997. From that time, many additional wireless standards have been de-

veloped such as Bluetooth for short-range and low throughput, Ultra Wide Band (UWB) for High Speed data rates, and Wireless Interoperability for Microwave Access (WiMAX) for long range. Unlike the cellular technology, these standards are mainly intended to support delay tolerant data services (e.g. mail, web, FTP etc ...). These two groups of technologies namely those intended for cellular services and those for fixed data services have merged over the years to offer high data rates even for mobile; what will be subsequently dubbed: fixed mobile convergence.

One year ago, the mobile world celebrated its four billionth connection [38]. Meanwhile Third Generation (3G)-based cellular networks continue to be deployed and 3.5G is already on the horizon. For the end user, it means that new and better services will become available. However, the problems of coverage and capacity are still open. These problems are even more severe for indoor users where reception is poor. Improvements in service to the indoor user should be meaningful especially when several surveys show that indoor traffic can reach more than 30 percent of the total access traffic [69].

At the same time, wireless local area networks such as WiFi are almost ubiquitous in most homes. WiFi users who purchased a dual-mode mobile phone, once arriving at home switch to their local wireless connection, and make free calls through Voice over IP software. Cellular operators interested in keeping their clients' loyalty have to find a competitive alternative. One of the most promising solutions is the deployment of femtocells. A femtocell is a box quite similar in appearance to the classical WiFi router and is plugged to the home's broadband network access for the internet. This technology is being tested worldwide by manufacturers and operators and might be a technology that will help cellular network operators.

## 1.2 Challenges

What technology to choose to achieve good indoor coverage, and the required data services?. There was a time when as mentioned above each technology corresponded to a specific service. This is no longer true. We need to understand in greater depth the capabilities of each of these technologies. For some wired technologies, simple calculations enable "rough" approximations. This is not the case for wireless, where the radio resources are shared. Whatever the considered multiple-access protocol, we must take into account the interference that might occur between or within the technology . Moreover even if one considered only a hypothetical cell "isolated from the rest of the world", one would consider the bandwidth "wasted" by

the multiple access protocol. In this present work we propose to evaluate the capabilities of two technologies: WiFi and femtocell. The difficulty of assessment for each of these technologies is not at the same level.

### **1.2.1 Capacity Evaluation of a Wifi Cell**

For the WiFi, the major problem is to get the residual and effective throughput a user can expect from its wireless access point. The WiFi standard is based on the well-known Carrier Sense Multiple Access with Collision Avoidance (CSMA / CA) mechanism which manages the multiple access to an access point by different users. This is done in a distributed manner. Each user must verify that the channel is free during a given amount of time (called Inter-Frame Space (IFS)) before transmitting. If the channel is busy, the user must wait again for a random time (known as Backoff time) to try a retransmission. Even when a station succeeds to transmit on a channel that is supposed "free", a collision can still occur. For example, if two stations connected to the same access point have by coincidence waited the same random time. This stochastic nature of the mechanism makes it difficult to get an accurate estimate of the actual capacity of the wireless cell. One could argue that if we do not want to take a risk, it is enough to oversize the network by introducing a large number of wireless access points to cover a given area. Unfortunately, this solution feasible at high cost with wire can lead to strong interferences between cells in wireless. In addition to the extent that CSMA / CA is used, the problem of the Exposed node will appear very quickly with an abundance of access points. Thus it is essential to evaluate precisely and accurately as possible the capacity of a wireless cell, in order to optimize the use of the radio resource available for each access point.

### **1.2.2 Qos Parameters for WiFi**

The original access mechanism of the WiFi standard, based on CSMA / CA was not designed initially to support quality of service. Thus there was no differentiation mechanism between flows from different kinds of services. This motivated the development of an amendment to the original standard which allows giving priority to certain types of flows (e.g. for voice services, streaming, etc). Unfortunately it required the introduction of different back-off times for each flow, which complicates the task of evaluation of the cell capacity. In addition, there are numerous parameters available within the Quality of Service (QoS) enhanced protocol that allow a network administra-

tor to dynamically manage the differentiation between the services. However due to the high complexity of the protocol and its random nature, it is not possible at first sight to define the influence of each parameter on the effective capacity available to each service. This evaluation can only be done through incremental simulations or analytical models.

## 1.3 Thesis Goals and Contributions

### 1.3.1 Stochastic Model for Wifi Access

To evaluate the capacity of a WiFi cell, a way to model the access mechanism of the radio resource was needed. Many models appeared shortly after the appearance of the standard. However, each model made some assumptions for purposes of simplification. The most common assumptions were the saturation of the channel and the approximation of an ideal channel. The channel can be considered saturated if a user always has a packet to transmit, or in other words that the buffer of the user is never empty. This assumption is often justified as it can be considered the worst case scenario which will not lead to overestimated capacity. However, this will obviously lead to an oversized network which is not desirable. In addition, this assumption is itself difficult to justify if we consider that a user rarely has a packet to transmit continuously. For instance, the traffic of a user viewing web pages has been the subject of intense research and often modeled for simplicity has a series of burst period followed by silence period maybe due to the fact that the user takes time to read the required information that has been downloaded and does not interact continuously. A second approximation often assumed in the existing models considers the channel as ideal. Thus, each transmitted packet arrives without error with a probability equal to 1 if it does not encounter a collision. It is well known that the wireless medium is far from being error free. If for the wired network, the BER is around  $10^{-14}$ , wireless networks have a BER of around  $10^{-7}$  or about 10 million times more errors. So once again we claim that this is a rough assumption. Finally, many models do not consider the enhanced access mechanism of the WiFi which supports QoS.

In this thesis we propose to model the access mechanism of a WiFi's cell with QoS support and without the aforementioned approximations of saturation and error-free channel. Indeed we consider the possibility that the buffer of the user can be empty with a given probability. Moreover, even if the user was granted access to the medium, there is non zero probability that an error occurs. For theses purposes we extend an existing model

known as Bianchi's model [16] which was further extended to accommodate the QoS enhancement by Kong [48]. The new model allows for more accurate dimensioning of a WiFi network. Moreover, the modeling of the QoS standard capability allows a better understanding of the influence of each parameter of the protocol. Thus our model may be considered as a tool for calibrating parameters of the network to give specific quality of service to different users.

### 1.3.2 Femtocell

The difficulty for the femtocell lies at another level. In fact the multiple access mechanism considered is, according to the generation: Code Division Multiple Access (CDMA) for 3G and Orthogonal Frequency Division Multiple Access (OFDMA) for 4G. These mechanisms are not stochastic, thus evaluation of the capacity for a cell is not really challenging. On the other hand if we take into account the neighboring cells, then we have to deal with interference scenarios. In addition, unlike WiFi, femtocells must consider the overlay macrocell. Indeed although femtocells allow better coverage inside, we still have to provide coverage for outside users not connected to a femtocell. This additional coverage overlays the femtocell like an umbrella. Therefore we have to face a new challenge which is spectrum allocation to the femtocell. It is now well known that radio resources are rare "commodities". If the femtocell reuses the spectrum already allocated to the macrocell this will necessarily induce strong interference between femtocell and macrocell, even if it seems to be an appealing proposal in terms of optimization. Dedicated spectrum for femtocell is not always possible if the operator does not have additional spectrum for this second layer of mini-base stations. Thus in order to evaluate the capability of a femtocell, we have to cope first with spectrum allocation.

In this thesis we propose an innovative scheme for frequency reuse between femtocells and macrocells. We propose to merge the two approaches mentioned above. Namely, we grant femtocell spectrum which would consist of dedicated frequencies from adjacent sectors of the overlaying macrocell. At the time we developed this idea there was still no methods of optimal sharing of frequencies between femtocells and macrocells. After granting the femtocell a spectrum, we can then consider the calculation of the femtocell capability in terms of signal to noise ratio achievable and therefore data rates. This calculation takes into account the interference generated by neighboring femtocells reusing the same frequencies, called co-channel interference, as well as those generated by users of the macrocell still on



camping on the same frequencies. Our contribution is manifold. Mobile operators will be able to optimize the use of the radio resource acquired. On the other hand we allow to evaluate the added value of a complementary coverage by femtocells, both from a femtocell user and macrocell user perspective.

## 1.4 Thesis Outline

This thesis has a somewhat original structure to the extent that we deal with two parallel competing technologies. The objective being to assess the capacity offered by each. We propose to deal in parallel with each of these challenges. The first part presents the technical background for a good understanding of the challenges and their solutions. Then, a thorough treatment of the state of the art for each issue is given. Due to the specificity of each technology each is presented in separate chapters. Chapter 2 shows the background and already existing works for dimensioning of a wireless cell. Chapter 3 presents the challenges to be overcome with femtocells and the various existing solutions already proposed. This parallelism is maintained until the end of the thesis. The second part presents our contribution to each of these issues in details. In Chapter 4 we present the stochastic model developed to fill the need for an accurate evaluation of the capability of a WiFi cell. Then in chapter 5 we present our scheme for double frequency reuse between femtocell and macrocell. The third part of this thesis presents the results from each of the proposed solutions. Chapter 6 reports the different performance achievements in terms of effective throughput and delay for a single cell under different load scenarios, probabilities of error etc. Chapter 7 presents the potential of femtocells mainly in terms of signal to noise ratio that can be achieved thanks to our reuse scheme. This thesis concludes with a brief comparison between the two technologies and some ideas for future works.

## Part I

# Background and state of the ART

In this part, we present the required background to understand how WiFi and femtocell technologies work. In the following chapter we present the access mechanism to the IEEE 802.11(a.k.a WiFi) radio interface. Modeling of WiFi's Medium Access Control (MAC) layer function has drawn the attention of hundreds of researchers throughout the world and will be therefore thoroughly detailed in Section 2.2. We further introduce the concept of femtocell in Chapter 3, with the challenges and existing work relative to the radio resources allocation issue. In the next part we present our contribution to all these problems with respect to the state of the art.

## Chapter 2

# Access Mechanisms to IEEE 802.11 WiFi Networks and Their Analytical Model

This chapter presents the mechanism of multiple access used in the Wireless Local Area Network (LAN) (WLAN) following the IEEE 802.11 standard. Then we provide a deep insight through the state of the art on this topic.

### 2.1 MAC of the IEEE 802.11 and 802.11e description

In the last years , WiFi products enjoy more and more interest from the consumer and therefore bring to the libraries quantities of literature on its mechanism. This chapter is an overview of the main concepts of WiFi followed by details of the MAC layer according to the original 1997 standard. Then the QoS amendment to the standard is explained.

#### 2.1.1 introduction

The IEEE 802.11 standard (ISO / IEC 8802-11) is an international standard describing the characteristics of a WLAN-Wireless Local Area Network (WLAN) [1] . The name Wi-Fi (contraction of Wireless Fidelity , and often denoted WiFi) is originally the name given to the certification allocated by the Wi-Fi Alliance, formerly WECA (Wireless Ethernet Compatibility Alliance), the body responsible for maintaining the interoperability between equipment meeting the 802.11 standard. WiFi allows broadband WLAN if

the station is not too far from the access point. The 802.11 standard defines two modes of operation [6]: infrastructure mode and ad hoc mode. In infrastructure mode, the wireless network has at least one access point (AP) connected to the wired network infrastructure and a set of wireless stations, whereas in ad-hoc mode, there is no AP but only set of Stations (STAs) that communicate directly with each other. The IEEE 802.11 standard defines only the two first layers of the OSI model: the Physical Layer (PHY) and the MAC (medium access control layer). The PHY layer defines how to transmit the bits on the physical medium including which modulation etc.. The MAC layer deals with scheduling of the user data into packets and then into the medium. In the next sections the core mechanism of the MAC will be described since our main contributions lie in the modeling of these mechanisms. Several nominal data rates can be achieved with the WiFi technology. It depends on the version of the standard used. The original version referred to as IEEE 802.11b uses the Direct Sequence- Spread Spectrum (DS-SS) technology which allows rates up to 11 Mbps in the ISM band. Later, a version based on Orthogonal Frequency Division Multiplexing (OFDM) technology was defined in the 5 Ghz band, which allows data rates up to 54 Mbps. This is referred to as IEEE802.11a. Finally, due to the success of the ISM band, an upgrade of the IEEE 802.11b, was defined in the ISM radio band but with the OFDM technology too, known as IEEE 802.11g. It allows data rates up to 54 Mbps but also compatible with the "b" version.

Since a WLAN relies on a common transmission medium, the transmissions of the network stations must be coordinated by the medium access control (MAC) protocol. MAC protocols for LANs can be roughly categorized into : random access (e.g., CSMA, Carrier Sense Multiple Access with Collision Detection (CSMA/CD)) and demand assignment (e.g., token ring). Due to the inherent flexibility of random access systems (e.g., random access allows unconstrained movement of mobile hosts) the IEEE 802.11 standard committee decided to adopt a random access CSMA-based scheme for WLANs[19]. The IEEE 802.11 MAC sub-layer defines two relative medium access coordination functions, the Distributed (Coordination Function) Interframe Space (DCF)) which is a contention mode and the optional Point Coordination Function (PCF) which is a contention free mode. The PCF mechanism was optionally from the beginning and was never implemented in a commercial product. Therefore, we will not consider it further.

### 2.1.2 Distributed Coordination Function

DCF is a distributed medium access scheme. In this mode, a station must sense the medium before initiating a packet transmission [56]. If the medium is found idle for a time interval longer than Distributed InterFrame Space (DIFS), then the station can transmit the packet directly. Otherwise, the transmission is deferred and the backoff process is started Fig.2.1. Specifically, the station computes a random time interval named Backoff time, uniformly distributed between zero and the current Contention Window size (CW),  $\text{Backoff time} = \text{rand}[0; CW]$ , where  $CW_{min} < CW < CW_{max}$  and Slot time depends on the PHY layer type. The backoff timer is decreased only when the medium is idle, whereas it is frozen when another station is transmitting. Each time the medium becomes idle, the station waits for a DIFS and then continuously decrements the backoff timer. As soon as the backoff timer expires, the station is authorized to access the medium. Obviously, a collision occurs if two or more stations start transmission simultaneously. In this scheme there is no collision detection capability due to the WLANs inability to listen while sending, since there is usually just one antenna for both sending and receiving and due to the significant difference between transmitted and received power levels. Hence, a positive acknowledgement is used to notify the sender that the transmitted frame has been successfully received. The transmission of the acknowledgement is initiated at a time interval equal to the Short InterFrame Space (SIFS) after the end of the reception of the previous frame see fig 2.2. Since the SIFS is smaller than the DIFS see fig. 2.1, the receiving station does not need to sense the medium before transmitting an acknowledgement. If the acknowledgement is not received, the sender assumes that the transmitted frame was lost and schedules a retransmission and then enters the backoff process again. To reduce the probability of collisions, after each unsuccessful transmission attempt, the contention window is doubled until a predefined maximum value  $CW_{max}$  is reached. To improve the channel utilization, after each successful transmission, the contention window is reset to a fixed minimum value  $CW_{min}$ .

The Network Allocation Vector (NAV) is used for MAC virtual carrier sensing, by updating the local NAV with the value of other stations' transmission duration. By using NAV, a station can know when the current transmission ends and channel is idle. In order to solve the so-called hidden terminal problem, an optional RTSRequest To Send (RTS)/Clear To Send (CTS) (RequestToSend and ClearToSend) scheme is introduced, see Figure 2.3. The transmitter sends a short RTS frame (20 bytes) before each data

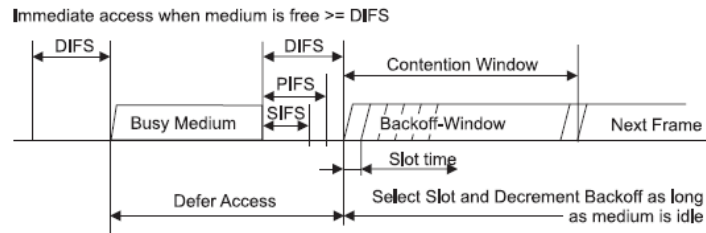

Figure 2.1: DCF interframe space [1]

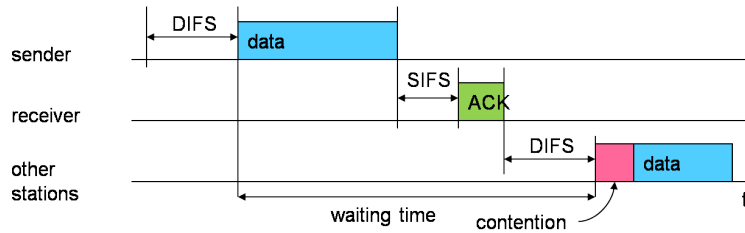

Figure 2.2: DCF access method

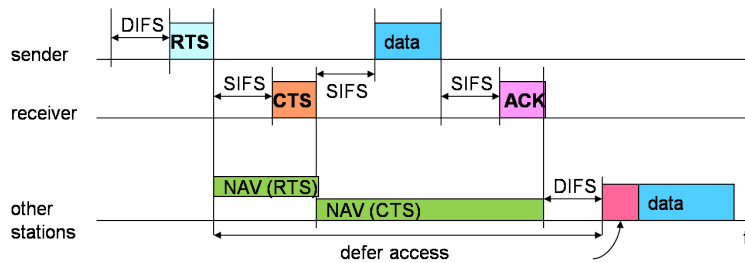

Figure 2.3: RTS-CTS protection and NAV

frame transmission. Note that a collision of the short RTS frames is less severe and probable than a collision of data frames (up to 2346 bytes). The receiver replies with a CTS frame if it is ready to receive and the channel is reserved for the duration of packet transmission. When the source receives the CTS, it starts transmitting its frame, being sure that the channel has been reserved for it during the entire frame transmission duration. All other stations in the Basic Service Set (BSS) update their Network Allocation Vectors (NAVs) whenever they hear a RTS, a CTS.

### 2.1.3 Enhanced Distributed Coordinated Access function

DCF does not provide any QoS(quality of service) support. It behaves like a FIFO(First In First Out) queue which provides best effort service. A voice call contending for the resource e.g. with a pending email , are considered equally from a priority perspective even if they are issued from the same station.

The Task Group (TG) E of the IEEE 802.11 group was formed in September 1999 and the project was approved in March 2000. In december 2005 the IEEE 802.11e [4] amendment to the original standard was approved and was incorporated in the last update standard in 2007 [6].In comparison to the 802.11 DCF basic access scheme, 802.11e can support 10 types of services. The 802.11e includes an access channel function called Hybrid Coordination Function (HCF) similar to the DCF and PCF of 802.11 original standard often referred to "legacy" standard. The HCF function itself is made of two sub access mechanisms (see fig. 2.4):

- contention mode EDCA
- centralized contention free mode HCF Controlled Channel Access (HCCA)(similar to PCF)

In the context of 802.11e all the elements involved in the network and that can support mechanisms for QoS management are preceded by a Q (for QoS), eg, a station that can support QoS will no longer be referred as STA but as QSTA , and AP will QoS AP (QAP) and so on. However a QoS STA (QSTA) must also include DCF to allow interoperability with legacy STA.

The EDCA is considered as an enhancement (as proposed by the name EDCA itself) of the DCF mechanism. Thus all the variables presented for the DCF (see 2.1.2) are generalized here. The EDCA has 8 different priorities referred to Traffic Category (TC) organized into 4 Access Categorys (ACs). Each  $AC_i$  has its own queue and its own characteristics such as its own IFS:



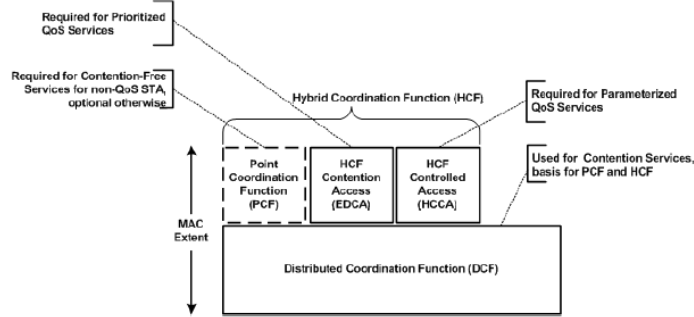

Figure 2.4: MAC architecture [6]

$AIFS_i$  (Arbitrary Inter-Frame Space formerly DIFS),  $CW_{min_i}$ ,  $CW_{max_i}$ . These values are set so that for  $0 < i < j < 3$   $AC_j$  characteristics values are always lower than for  $AC_i$ . In this way the AC with the higher index will have more chance to access the channel (due to smaller waiting times), see Fig. 2.6.  $AIFS$  is calculated as  $AIFS_i = SIFS + AIFSN_i \times aSlotTime$ . Where  $aSlotTime$  stands for the time slot length which depends on the PHY (802.11 a or g or b etc..typically a few micro seconds, see Table 6.1).

Whenever a packet (referred to MAC Service Data Unit (MSDU) for MAC Service Data Unit) arrives at the MAC layer it's mapped to one of the  $AC_i$  fig. 2.5. Then when it is at the top of the  $AC_i$  queue, it senses the channel during  $AIFS_i$  (as configured by the network administrator or by default) and if idle it transmits the packet.

If the medium is not idle, it initiates the backoff period just like the legacy DCF, with  $CW$  of the  $AC_i$ . The EDCA proposes a novel scheme to deal with internal collisions, where two packets from different  $AC_S$  in the same STA want to transmit. In this case, e.g. the backoff of the two different  $AC_S$  end at the same time, the  $AC$  with the highest index will transmit first.

After each failed transmission, a new Contention Window ( $CW$ ) is calculated (as for the DCF see 2.1.2). However unlike the DCF where the  $CW$  is always doubled after each failure, in EDCA a Persistence Factor  $PF$  is introduced that is specific for each  $AC$  to increase differentiation between  $AC_S$  (notice that for DCF it's equivalent to  $PF = 2$ ). Thus after a failure the new  $CW$  is computed as  $newCW_i = ((oldCW_i + 1) * PF) - 1$ . The  $CW$  is therefore incremented until it reaches a maximum allowed value  $CW_{max_i}$  just like the DCF.

The values of  $AIFS_i$ ,  $CW_i$  etc.. specific to each  $AC_i$  are announced

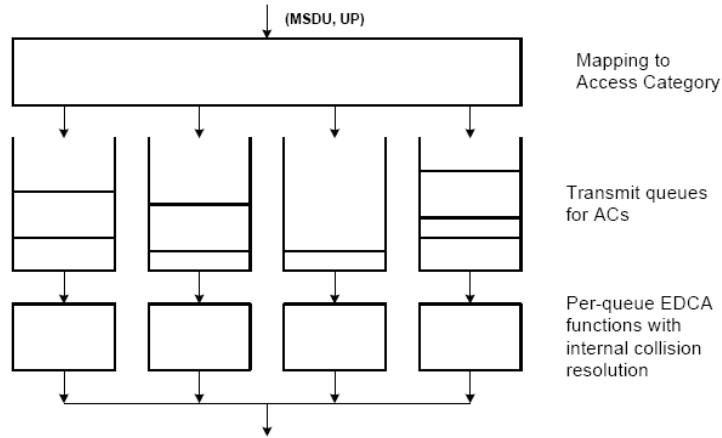

Figure 2.5: Mapping to one of the AC [6]

by the QAP through beacon frames that are transmitted periodically. The QAP can adapt these parameters according to the traffic in the network. For instance, when the network is loaded, it can be useful to vary the parameters e.g. increase the AIFS value of best effort *AC* to decrease collision probability and allow the voice category to transmit. However the algorithm of how to tune these parameters with respect to a given load traffic is not provided by the standard and is left to the manufacturer to decide. According to management policy settings of each vendor, there will be more or less good service experienced by the user. This can be an element of product differentiation.

## 2.2 State of The ART

Since the first IEEE 802.11 standard in 1997 [1], research laboratories kept on trying to model the behavior of access mechanisms to the medium. Indeed, it is difficult to model the distributed coordination function (DCF), particularly due to the number of parameters that change during the transmission. A relevant and efficient model would constitute a key to assist the deployment of wireless networks, which is currently done in a quasi empirical way. As far as we know, there exists no software to evaluate the exact capacity of a cell where users have very different requirements in quality of service (QoS); taking into account the overhead induced by the contention

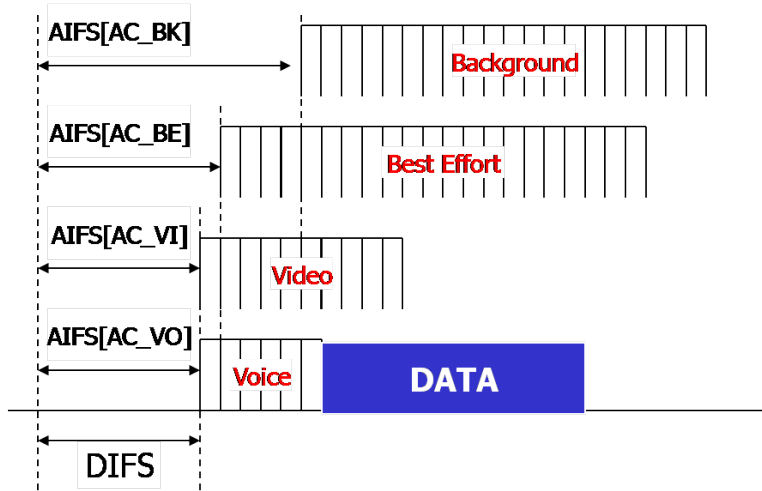

Figure 2.6: AIFS prioritization mechanism of EDCA

process; and the collision. Thus, it is necessary to calculate the probability of collision, errors over the channel, and also the average time spent in contention period.

### 2.2.1 Seminal Models

We distinguish two main categories of models. Since 1996, the CSMA/CA mechanism used by the DCF and its performances were studied by Bianchi [17]. This model which is based on **Markov chains** was published in 1998 [15]-[16]. In parallel, Cali et al. [18] developed a model based on **geometric distributions**.

The Bianchi model is based on a two dimensional Markov chain. The first dimension  $s(t)$  indicates the backoff stage which represents the number of transmission attempts which failed. The second dimension  $b(t)$ , indicates the value of the backoff timer, which corresponds to the number of time slots to wait before being able re-initialize a transmission after a failure. This model is a good fit for a saturated medium because it assumes that the STA always has data to transmit. This implies that the results represent the maximum throughput offered by a WiFi cell. However, this model uses several approximations. Firstly, the channel is supposed to be ideal, i.e., it does not introduce any error. Moreover, the limited number of retransmissions allowed in the standard is not taken into account in the model. The model seems to be more accurate only when there are a great number of

stations. Besides delay is not derived.

Cali's model also allows to compute the maximum flow offered in saturated mode for the DCF, but this time, the backoff time is evaluated as the average of a geometric distribution. Although both Cali's and Bianchi's models use the same approximations, a major difference between those two models lies in the way of computing the probability for a station transmitting at a time  $t$  (the computation being easier in Cali's model).

### 2.2.2 DCF models

In order to enrich these two models, several papers were published that tried to improve one of the approximations listed previously.

[72] developed a model with an error-prone channel based on Cali's model. We notice that the maximum attempt of retransmissions is not taken into account. This model leads to a finite load of the network, thus it can be considered as a non saturated model. It is based on geometric distribution [73] and relies essentially on the work of Tobagi [65] who used matrices to represent the state variations of the network. Each node of the network is in a "thinking" state if it's either waiting for a packet to transmit or has already succeed to transmit a packet in the first attempt. Otherwise the node is in "backlogged" state where the packet is still waiting in the buffer or being transmitted by the station. The matrices account for the transition probabilities from a system of  $i$  backlogged nodes and  $M - i$  thinking nodes to  $k$  and  $M - k$  respectively.

Several improvements of Bianchi's model have also been proposed. Among the refinements, one is due to [75] aiming to capture the freezing of backoff counters when the broadcast channel is sensed busy by a station. However an inaccuracy in the model affecting several important measures was reported later, and corrected in [32]. [22] derives the delay but still in the saturated mode with ideal channel assumptions. The assumption is that the average backoff time that a station wait in the contention period equal to half of the contention windows, in the same way of Cali [18]. However the probability that a station transmit is derived in the same way as Bianchi [15] which leads us to consider this model as an extension of the Bianchi's model. [29] improves Bianchi's model by taking into account an error prone channel, but still with the saturation assumption. The error probability is not integrated in the markov chain but directly in the calculation of the collision probability.

[20] examined unsaturated networks, by introducing an additional state into the Markov chain. This state takes into account the possibility of having

an empty buffer after a transmission. The model deals with an additional problem, which is that of the multi-rate STA. It is achieved by taking into account the rate of each of the stations in the derivation of the transmission time of data. However, this work was carried out within the framework of an ideal channel, and does not take into account several significant characteristics of the DCF such as the frozen time when the channel is busy. It's worth to mention that the model was compared against real measurements from a 802.11b testbed developed for this purpose. A similar treatment of finite load can be found also in [10].

Some other models were used to derive performance of the DCF. For example we can mention [40] based on stochastic per networks.

### 2.2.3 EDCA models

The IEEE 802.11e standard [4] including mechanisms for QoS management, has also been studied, in saturated mode [48], [57], [30], [55]. These models are both based on Markov chains and extend the Bianchi's model. They assume that the system is in saturated mode and that the channel is ideal. It's worth to remind that all the mentioned models including our model presented further deal only with the infrastructure mode of the IEEE 802.11 (i.e. single hop). Ad-hoc mode or multi-hop is not considered. [49] also extends the Bianchi's model but without introducing a new state in the Markov chain. Instead, it deals with the multiple access categories directly in the computation of the collision probability.

In [13], a model to analyze the delay behavior of the EDCA mechanism is presented. The collision probability is computed with the assumption of Cali's model [19] that backoff times follow a geometric distribution. Delay derivation following the Bianchi's model is computed in [14] and is a direct extension of [55].

An interesting approach is found in [42], which presents a unified model based on three different seminal models [15],[18],[64]. (the two first were explained in 2.2.1). Backoff stages are still accounted for by using a bidimensional-state Markov Chain as in [16] but in order to account for the effect of different AIFS values, we did not introduce further dimension(s) to the state space. Instead they used multiple bidimensional chains which easier to apply because reducing the complexity of Markov chains, what the authors claimed.

### 2.2.4 Summary Table

	Performance Metric		Protocol		Assumption				Validation		Type		
	Delay	Throughput	DCF	EDCA	Non-Saturated	Saturated	Error Prone	Error Free	Simulation	Experiment	Cali	Bianchi	Other
[16]		X	X			X		X	X			X	
[18]		X	X			X		X	X		X		
[57]		X		X		X		X	X			X	
[20]	X	X	X		X			X		X		X	
[73]	X	X	X		X		X		X		X		
[48]	X	X		X		X		X	X			X	
[29]		X	X			X	X		X			X	
[49]		X		X		X		X	X			X	
[10]		X	X		X			X	X			X	
[40]	X	X	X		X			X					X
[30]	X	X		X	X			X	X			X	
[42]	X	X		X		X		X	X		X	X	X
[55]		X		X		X		X	X			X	
[14]	X			X		X		X	X			X	
[13]	X			X		X		X	X		X		
Our model	X	X	X	X	X	X	X	X	X			X	

Table 2.1: State of the art summary and comparison of DCF and EDCA Stochastic models

## Chapter 3

# Frequency Allocation to Femtocell

### 3.1 Introduction

Literally the term femtocell in the context of cellular networks refers to the size of a cell covered by a Home Base Station (HBS). It is the logical extension of the already existing sizes which are macrocell, microcell and picocell. Whereas a picocell is mainly intended for densely populated areas such as airports, malls, etc., a femtocell is a Personal Base Station that can be deployed in each house. It has been more than ten years since operators started to reduce the size of the cell covered by a Base Station (BS) to support an increasing number of subscribers and to support large number of concentrated indoor users. The need to provide high quality coverage indoors became more critical when data oriented services were introduced, because such services require higher throughput in order to be considered attractive. Even after the appearance of the CDMA technology which led to the Third Generation (3G) technology, the problem of throughput remains. In addition, as people use their cell phones more and more, the indoor use of mobile phones increases. Since 2002, mobile subscribers worldwide have outnumbered fixed-line subscribers [43]. The indoor environment is so challenging that users were rapidly dissatisfied and looked for an alternative. Some alternatives recently considered are the use of relay [58] or multi-hop networks [51].

Recent years have brought an exponential increase in the use of wireless access to the internet at home. As the deployment of wireless routers increased, and with the introduction of Voice Over IP (VoIP) software, which

allows for free phone calls, people wanted to mix these two opportunities. This gave birth to the Dual-Mode handset, which consists of a mobile device supporting both cellular technology standards such as GSM, and wireless local area network standards such as the IEEE 802.11 standard promoted by the WiFi alliance. This "smart" solution began to be, and still is, a real threat for cellular operators as some users no longer use outdoor cellular networks deployed by operators to make their indoor phone calls but instead use their cheaper access to the internet. That is why the concept of femtocell started gaining prominence about two years ago. In fact the concept of femtocell (also called HBS) is not really new. It has already been proposed in the mid-90 by Silventoinen et al. with the GSM-based HBS [61]. It was thought of as a device that a GSM subscriber could buy and connect to his fixed telephone (PSTN) line. This concept has even been standardized within European Telecommunications Standards Institute (ETSI) [2] few years later and referred as GSM Cordless Telephony System (CTS)). However this innovation did not attract much attention of the manufacturers then, but can now be considered as the seminal work of what we call femtocell. Actually this is seriously considered by operators who are struggling to keep their subscribers loyal. It's also worth mention that about 10 years ago, before HBS was proposed, a similar concept was also considered. It consisted in one handset which would be connected to the regular cellular network when outdoor but as soon as the user entered the home it would connect to the Wireless Private Branch eXchange (PABX) which is the predecessor to actual cordless telephone technology such as Digital Enhanced Cordless Telecommunications (DECT).

## 3.2 Description

"To be considered as a candidate" to own a femtocell, a user must have a broadband connection to the internet. The user then must buy a box similar in appearance to a regular WiFi router and plug it into the home network. It is important that a femtocell remains a simple Plug-and-Play device, as a complex installation process is likely to prevent clients from adopting it. When the user enters their home, the femtocell will detect the mobile handset and vice versa, and a connection will be established. Then all phone calls initiated by the mobile handset from indoors will be supported by the femtocell. The underlying technology to be used can be theoretically one of the three last generations: 2G (e.g. GSM), 3G (e.g. UMTS) or 4G (e.g. Long Term Evolution (LTE)). The technical challenges are clearly different



whether we choose 2G which is based on Time Division Multiple Access (TDMA), 3G based on CDMA or 4G based on Orthogonal Frequency Division Multiple Access (OFDMA). As 3G systems are currently deployed worldwide, we will focus here on this specific technology. In the context of 3G the HBS is called Home Node B where Node B stands for the classic macrocell BS. We will however refer to it further simply as femtocell. 3G technology is based on CDMA which means that all the users can transmit at the same time over the whole bandwidth. To distinguish between signals from different users, different spreading codes are used for each user. CDMA based systems have full frequency reuse which means that the same spectrum is reused in all adjacent cells. To overcome the problem of Co-Channel Interference, power control and scrambling codes which distinguish between downlink signals from two different base stations are used. When a Mobile Station (MS) moves closer to the edge of its current cell, the process of handover is triggered. The introduction of an additional tier in this already heavy loaded and complex cellular architecture system exhibits several challenges.

### 3.2.1 Access Control

Users can be classified in two categories, depending on the connectivity rights that they are given to the Femtocell Access Point (FAP) [74]:

- A subscriber of a femtocell is a user registered in it
- A non-subscriber is a user not registered in the femtocell

According to 3GPP, three access methods to the femtocells, have been proposed: closed access, open access and hybrid access. The closed access mode is also called Closed Subscriber Group (CSG). In CSG only subscribers can connect to their femtocell whereas open access femtocells are accessible by everyone. In hybrid access, subscribers have a preferential access to their femtocell, and non-subscribers have the right to connect with limited access to the femtocell resources [53]. If we consider 3G technologies, the problem of Co-Channel Interference (CCI) can be unbearable and for this reason open access should be mandatory, even though manufacturers actually, use some advanced techniques to overcome CCI. In fact in 3G technologies, the CDMA technique allows full frequency reuse but on the other hand strong power control has to be carried out and it is not always possible with femtocell. With the 4G technologies based on OFDMA, CCI can be mitigated through partial frequency reuse as we will show further in section 5.1, and thus open

access is not necessary. For this reason we consider here that access to a femtocell should be granted only to the user who owns it in other words CSG method.

### 3.3 Challenges

One of the main challenges with femtocell lies in radio resource management. We need to remind ourselves that this issue is less critical in the case of WLAN, where access points do not have to co-exist with an overlaying macrocell. Moreover the access mechanism of the WiFi technology relies on carrier sense and collision avoidance mechanism, which avoids interference (for further details see Chapter 2). Nevertheless, femtocells have to take into consideration the neighboring femtocells and also the overlaying macrocells. We list four interference scenarios that could occur when a FAP serves a FUE (see also [7]). In fact there are also other scenarios such as femtocell to Macrocell Uplink attack etc., but they are quite similar to the ones we present in the following paragraphs.

#### 3.3.1 Femtocell to Macrocell Downlink Interference

Assume a MUE receiving data from its far MAP, for example, we consider the MUE located at the edge of the cell covered by its MAP. Consequently the received signal at the MUE is very low due to the distance between MAP and MUE. Meanwhile a FUE very close to the MUE is receiving data from its FAP, e.g. when a pedestrian is walking along the edge of the street near the FUE home, or even a user who does not belong to the FAP subscriber group. As the FAP is likely to be close to the FUE, the downlink transmission between the FAP and the FUE will strongly disturb the ongoing downlink transmission in the macrocell. Under certain conditions it could even lead to a dropped call for the MUE.

#### 3.3.2 Macrocell to Femtocell Uplink Interference

In this attack we assume that the MUE is transmitting to its far MAP. It requires a high transmission power so that the MAP could be able to receive the signal over the reception power threshold. At the same time, a FUE is transmitting to its FAP. Given their location are so close, the FUE can transmit at a low power. This feature is important because it can save the power battery of the FUE. Thus, the consequence is that the uplink transmission in the femtocell will be strongly interfered by the MUE.

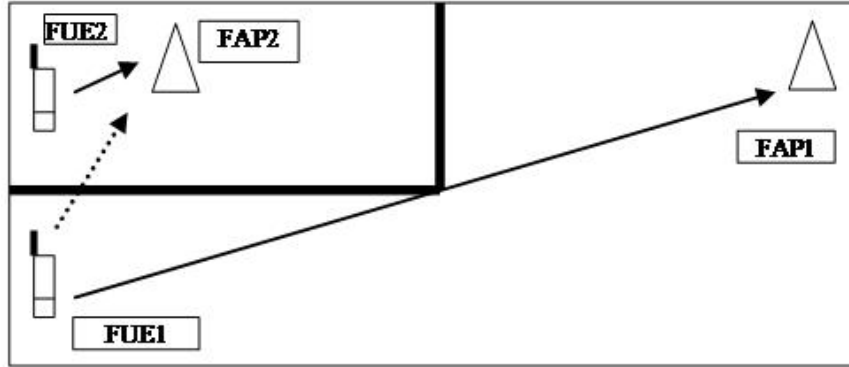

Figure 3.1: Femtocell-to-Femtocell Uplink Attack

### 3.3.3 Femtocell to Femtocell Uplink Interference

In this scenario and also in the next one, we focus on the interference between femtocells. All the elements are located indoor. Assume FUE1 transmits to its FAP1 and that the distance between each other is maximal, for example if the user is at the opposite side of the FAP in the house, as shown in Fig.3.1 . At the same time, suppose that FUE2 transmits to its very close FAP2. As already mentioned, the bigger the distance between the FUE and FAP, the higher the transmission power. Consequently, in our case the transmission from FUE1 will likely interfere with the one from FUE2.

### 3.3.4 Femtocell to Femtocell Downlink Interference

Similarly to the previous scenario, we consider here that FUE1 is receiving from its far FAP1. Meanwhile, FAP2 is transmitting to FUE2. Suppose that FAP2 is closer to FUE1 than FAP1, the transmission of FAP2 will interfere and cause a degradation of FUE1 call.

## 3.4 Existing Allocation Scheme

Several methods have been suggested (see Section 3.4.3) to cope with all or part of the problematic scenarios mentioned. In the following we separate the challenges into two parts: the cross tier interference referring to the interference between femtocells and macrocells and the co-tier interference for the femtocell to femtocell scenarios. Most existing works separate those two challenges. Usually researchers will focus their work on only one of these

challenges at a time. Thus we will present the state of the art in two separate parts for each of them. In section 3.4.3 we present the solutions proposed to deal with the problems of frequency allocation to hierarchical multilayer cells. Then in section 3.4.4 we present the multiple algorithms and schemes to allocate radio resources to different stations belonging to the same tier. However because some solutions were presented specifically at the macrocell or even at the femtocell level we further subdivide this part into two groups of solutions : the macrocell layer and the femtocell layer (each one will be presented separately). Finally we summarize in Table 3.1 the characteristics of most of the solutions presented. This would allow someone faced with a specific challenge to quickly find a solution fitting to a similar problems.

### 3.4.1 Introduction

It is interesting to note that as we mentioned in the introduction above, the concept of femtocell is not so new and was already considered at the end of the 80's. However even though some papers already considered the issue of frequency assignment for this second tier system, recent papers on femtocell do not mention them generally. A possible reason is that the term used in those days was different from the one we use today, so some important results can easily be overlooked. Here we propose to list the different terms found in the early literature which dealt with the concept of femtocell but which did not refer to it with this latter name:

- CTS where the access point is called CTS Fixed Part (CTS-FP)
- indoor Base Station (BS)
- indoor cellular radio PBX(private Branch Exchange)
- Home Base Stations (HBS)
- digital cordless telephone PBX [71]
- indoor cellular system/radio [46]
- indoor microcel for cordless telephone PBX [36]

In fact, another second tier was also considered some time before at the end of the 80's: the Microcell. The concept of hierarchical networks or multi-tier (also called multilayer) cellular systems rapidly appeared to be a logical extension of the cellular system. Hot spot are covered by microcells (layer 1) while macrocells provide a continuous coverage of the service area (layer 2).

In very dense areas, a continuous coverage with both microcells and macrocells may be achieved [50]. However the intensive deployment of microcell BSs is generally more expensive than conventional macrocells deployment because of the potentially high number of sites. Hierarchical architecture has to be carefully optimized so that both layers can act complementarily [23]. Thus some papers already dealt, with the issue of the efficient use of the spectrum between Macrocell and Microcells in these years. We thus obviously learned from this method to apply them naturally to the new extension layer: the Femtocell.

### 3.4.2 Experimental Results in the Literature

In [69], a series of experiments were reported. Even though effective airlink data rate was measured, the main data captured was Signal to Interference and Noise Ratio (SINR) to concentrate on coverage quality rather than application layer throughput so as to be independent of the Internet and backhaul. The conclusion of the study is that femtocells outperform macrocells in terms of broadband airlink data rates by almost five to one. The authors also defend that the main benefits of femtocells over macrocells is for data services since voice services are not really "hungry" in bandwidth and therefore do not provide additional value compared to the macrocell offered service. However the main drawback of this study is that femtocells were deployed in a dedicated carrier thus avoiding interference from macrocells which is actually one of the most challenging issues for 3G femtocells. Besides the interference between femtocells is obviously not taken into account as the experiment rely on only dozens of femtocells spread over the whole world. Nevertheless the measurements constitute a good database for engineers who are developing simulators and can also be considered for surveys of femtocell in 4G where dedicated spectrum is possible and seriously considered.

### 3.4.3 Cross-Tier Allocation Scheme

The first to consider frequency reuse of the overlaying macrocell by a second layer system was Kinoshita et al. in [46]. They introduced the concept of "frequency Double Reuse" (DR) technique, which allows urban frequency channels to be also used in indoor cordless telephone systems. They further extend this idea to the coexistence between macrocell and microcell systems in [45] and [47] where the frequency channel used in the nearby cell is reused in a microcell inside the same cluster of macrocells and considered by the

authors as a high density space division multiple access (SDMA). This latter work has been extended by [35] to consider Dynamic Channel Assignment (DCA). The authors argue that it is hard to plan channel reuse in advance between the macrocells and microcells, since the wave propagation becomes highly irregular in the microcells. Therefore the Fixed Channel Assignment (FCA) proposed by Kinoshita et al. seems to be impossible in the microcells systems overlaid with macrocells. However [35] still requires power control and an increase in the implementation cost. In [68] a tradeoff between FCA and DCA is proposed. A classic 7-cluster reuse is used but the sectors are arranged in an original manner. It is proposed to rotate the sectors in each cell in a way that would avoid interference from co-channel adjacent sectors.

In [62], Silventoinen addressed the problem of allocating frequency to GSM-based femtocells (referred therein as Home Base Station). A Total Frequency Hopping (TFH) is used where transmissions of different HBSs take place in different carrier frequencies and the hopping is spread over all the available carriers the operator has in a pseudo-random way. The hopping sequences for individual HBSs are independent of each other. The TFH scheme eliminates the need for frequency planning since all frequencies are used in a pseudo-random manner and the additional interference to the overlaying system is evenly distributed over the whole spectrum in use. The conclusion for the downlink (the only direction simulated there) is that if HBS power is about 40 dB less than in macro networks, negative effect of the macro on the second layer HBS is negligible. Further investigation on transmission power for HBS, and effects on macro layer following the density of HBSs can be found in [27].

For the cross-tier interference, two main approaches are possible : Spectrum splitting or spectrum sharing. In the first approach macro and femtocells are given orthogonal frequency bands, also referred to as "orthogonal sharing" [50],[31]. This approach seems to be the simplest one, as no cross tier interference is expected. Thus both macro and femtocell tiers can be considered as totally separate networks. However a drawback is, that it is not efficient, because splitting the already allocated spectrum into two smaller ones would imply lower throughput to macrocell users which is not desirable. Moreover even in the rare case of an operator with a large spectrum for which this approach is a simple and straight-forward solution, an optimum division of the spectrum between the layers still has to be derived [33], which is not an obvious issue [34]. In the spectrum sharing approach the same spectrum is used by the macro and femtocell infrastructure, which obviously leads to the critical problem of co-channel interference. A third possible approach is that the different layers share several radio frequencies

but not at the same time [31]. Such a dynamic sharing may be provided by means of dynamic channel allocation.

In [24], the authors evaluate four approaches to sharing the spectrum between microcells and macrocells . The first two feature spread-spectrum sharing, i.e., they use TDMA among microcell users and CDMA among macrocell users (System I), or vice versa (System II). The other two approaches feature orthogonal sharing, i.e., they use TDMA in both tiers, with time slots (System III) or frequency channels (System IV) partitioned so there is no overlap between tiers. It is concluded that spread spectrum between layers is possible but will provide poor capacity because of the large amounts of cross-tier interference. The best approach is the simplest one: use different frequencies for different layers (System IV).

In [28] they study the ability of hierarchical cellular structures with inter-layer reuse to increase the capacity of a GSM radio network by applying Total Frequency Hopping (TFH) similarly to [61] and Adaptive Frequency Allocation (AFA) as a strategy to reuse the macro- and microcell resources without frequency planning in indoor picocells. In the macro- and microcell layer different frequencies are used to avoid the coordination effort between the layers. At the picocell level several scheme are proposed: reuse part or all of the frequencies of either only Macro or Microcell spectrum where less interfered channels are selected. Partial loading is assumed in each of the layers. One of the interesting conclusions of this study is that it is more efficient to exclude the strongest interferers than to achieve a higher interference averaging gain by using as much frequencies as possible for TFH. Unlike [28] where Macrocell and microcell use different frequency bands, in [11] a frequency reuse scheme where microcell reuse the macrocell frequency is proposed. However there are some limitations: microcells can reuse only channels used neither by the overlaid macrocell nor by the adjacent cell which would lead to adjacent channel interference. Moreover it has been shown there that microcell users have to transmit in the Uplink at a power level at least 10 dB below macrocell users, because of the interference induced by microcell users on the Macrocell. However Microcell BSs have to transmit with the same power as Macrocell BS, to be "heard" by microcell users in the downlink. This latter condition is possible because the macrocell downlink is almost unaffected, due to the isolation of the micro BSs. It is important to notice that interference between microcells (Micro to Micro) is not studied.

In [39], a frequency assignment for femtocells is proposed. The coverage of the macrocell is split into 2 regions: inner and outer regions. If a femtocell is located in the outer region, it can reuse the channel of the overlaying macrocell. However if the femtocell is in the inner region, it must use a

different channel than the overlaying macrocell. To compute where the limit must be between inner and outer region, the ILCA (Interference-limited coverage area) of a femtocell is defined. It is the area within a contour where the received power levels from the FAP and MAP are the same. If the ILCA is above a threshold, the femtocell is considered in the inner region. This frequency assignment method applies only to downlink, and it is not mentioned in [39] which frequency is allocated to the femtocells located in the inner region.

In [44], an uplink femtocell power control is proposed. It reduces the cross tier interference at the macrocell level. The study is in the context of the OFDMA WiMax system which can be also useful for LTE systems. However the power control proposed is not always realistic. In some cases, controlling the uplink transmission power of the femtocell to not disturb the macrocell, can lead to too low transmitted power and the FUE could not be covered by its FAP. Another solution proposed, is to share the resource in a TDMA fashion manner on top of the CDMA [21]. Macrocell and femtocell will each transmit independently over one time slot and remain silent over other slots. This is referred to as Time Hopped-CDMA (TH-CDMA). However it is in fact equivalent to splitting the resources in the time domain instead of splitting them in the frequency domain. As already mentioned for spectrum splitting, the loss of resource efficiency in an environment where radio resources are so scarce constitutes a major drawback.

#### 3.4.4 Co-tier allocation scheme

In the following paragraphs we present some of the algorithms developed to allocate channels to the users of a single layer. We did not detail this part because (as we will see further) we did not propose in this thesis a novel scheme of channel allocation between femtocells. We assume that a simple allocation based on best SINR is enough to be able to retrieve interesting results on our double frequency reuse schemes and therefore to assess potential performance of femtocells. However we find useful to bring here some references to existing work, especially to illustrate some of the characteristics of the femtocell mentioned above in section 3.2 such as Access Control subsection 3.2.1. Moreover we get inspired from some of these works for the frequency allocation scheme we will proposed further in Chap. 5.



## Macrocell layer

When we deal with frequency planning at the macrocell level we need in particular to consider the underlying multiple access mechanism. For example it is well known that in CDMA systems, the Frequency Reuse Factor (FRF) is equal to 1. Transmission to and from different users can be separated thanks to scrambling and spreading codes [70]. However in OFDMA systems, if the FRF is also equal to 1, this may lead to CCIs due to the simultaneous use of the same subchannels by different users in adjacent cells. Thus one of the challenges thoroughly studied in the literature is how to assign and reuse the scarce bandwidth to reduce CCI. Obviously, increasing FRF is not really spectrum efficient.

The use of Frequency Hopping techniques applied to OFDMA referred to as frequency hopping OFDMA (FH-OFDMA) which uses the frequency diversity by interleaving and spreading the transmitted subcarriers over the whole bandwidth, and averages the inter-cell interference is considered in [63] and [67]. In [52] splitting each cell into two region is proposed. The first region is the central region close to the BS and the second region is the edge which is itself split into three sector. The channel allocation is done as following : two groups of frequencies are defined: the super group and the regular group. The central region uses frequencies only from the super group with  $FRF=1$  whereas the edge uses frequencies from the regular groups split into the 3 sectors with  $FRF =3$  . Regular Group reuses frequencies of the central region of other cells, but not from its own cell since it would lead to severe intra-cell interference.

In [37], resource allocation on OFDMA context is considered but only at the macrocell level. Centralized and distributed scheme is proposed. In centralized the allocation is done in 2 steps: at the high level an allocation in the time domain is achieved where a sets of Resource Block (RB) (which is the unity of resource in LTE) is allocated to each MAP. This is done by a central coordinator which implements an algorithm which minimize the intercell interference. Then in a more fine time domain, each BS allocate a RB to a user based on an algorithm such as proportional fairness. In the distributed scheme, allocation is done thanks to power profile defined *a-priori*. Thus each cell know by advance to which level of interference it will be exposed. These propositions even though interesting cannot be used for femtocell as it requires a central coordinator. Even for the distributed scheme, profiles have to be already defined which is not really possible with femtocell which is plug and play without operator's planning before. Besides algorithm to define the power profile is not defined in this paper but pre-

sented as an open issue.

### **Femtocell layer**

A self-organized resource allocation algorithm for femtocell is presented in [54]. A sub-channel is allocated to a Femtocell based on either local broadcast messages from neighbouring FAP referred to as broadcast approach or from FUE measurement periodical report. In the broadcast approach, a "badness" indicator for each subchannel is computed. This indicator reflects the probability of usage and the intensity of interference for the sub-channel. In the second approach, each FUE sends a measurement report to its serving FAP which indicates the RSS suffered by the user in each sub-channel. Then the FAP gathers the information received from all of its FUEs and builds an interference matrix. A new subchannel is chosen following an optimization procedure whose target is to minimize the sum of the overall interference suffered by the users of the femtocell. This paper does not deal with the spectrum allocated originally to the femtocell but considers it as given. Besides prediction of interference which is needed for computation of the "badness" indicator is based on too simple propagation model which is mainly the free space loss model with added loss for wall penetration. However indoor wireless channels is well known for suffering from fading so we lack a more reliable propagation model.

Effects of open access versus CSG to femtocell to outside users have been analyzed in [66]. It shows that when CSG is used the outage probability for non-subscriber users is high whereas if even one sub-channel is reserved for them, the outage probability not only decreases but resources reserved can be sufficient if non-subscribers request voice services. An interesting observation is that if the quantity of subchannels reserved is low, then even if the number of femtocells deployed increases the outage probability increases due to cross tier interference on non-subscribers not yet associated with the femtocell. It proposes that providers or femtocell owners define minimum numbers of subchannels available to non-subscribers in a dynamic manner. It is worth mentioning that the coverage is predicted using the Finite-Difference Time-Domain (FDTD) method based on ray tracing theory which can be considered as very accurate. However the number of MUE users does not increase to up than 5 meanwhile which is not really representative of an urban or even sub-urban area.

	Technology			Access		Interference Scenario		Spectrum		Direction		Algorithm	
	2G	3G (CDMA)	4G (OFDMA)	Open	Closed	Inter-tier	Intra-tier	Shared	Dedicated	Downlink	Uplink	Centralized	Distributed
[39]		X	X			X		X	X	X		X	X
[61]	X				X	X		X				X	X
[44]			X			X		X			X	X	
[21]		X			X	X		X			X		X
[28]	X			X		X		X	X	X	X	X	
[11]	X			X		X		X		X	X		X
[37]			X	-	-		Macro	-	-	X		X	X
[54]			X		X		Femto		X	X	X		X
[66]			X	X	X	X			X	X	X	X	
[52]			X	-	-		X	X	X	X	X	X	
[46]	X				X	X		X				X	
[35]	X			-	-	X		X					X
Our scheme			X		X	X	X	X	X	X	X		X

Table 3.1: State of the art summary of frequency channel allocation scheme for macrocell and femtocell

## Part II

# Our Proposition

## Chapter 4

# Stochastic Model of EDCA

### 4.1 System Model

Our work is an improvement of the IEEE 802.11 and IEEE 802.11e existing models, and we chose to follow the methodology presented in [48]. Indeed, our objective is to provide a more realistic and extensive model. Thus, we suggest the following improvements: we consider a non-ideal channel (i.e., which introduces errors into the packets, according to a fixed error probability), and we consider that stations may be idle (i.e. the emission buffer of the network card can be empty). Indeed, assuming an ideal channel is a rather coarse simplification in the field of wireless transmission. Moreover, the saturated medium which is usually considered to evaluate the capacity of the network only indicates the maximum capacity of the link. Up to our knowledge, there is no EDCA model that takes into account a non-ideal channel under finite load.

#### 4.1.1 Four Dimensional Markov Chain

The Markov chain represented in Fig. 4.3 models the behavior of an access category (AC) managed by EDCA, for a given station. In order to simplify the diagram, we did not represent all the transition probabilities from one state to another. Our model comprises a great number of indices and variables, which are summarized in Table 4.1.

The so-called Bianchi model is based on a two dimensional Markov chain. The second dimension  $b(t)$ , indicates the value of the backoff timer, which corresponds to the number of time slots to wait before being able to re-initialize a transmission after a failure. This model fits well to a saturated medium because it assumes that at any point in time, STAs have data to

Var.	Explanation
$s(t)$	Number of retry at time t
$b(t)$	Backoff timer at time t
$v(t)$	Timer in transmission, collision, error or frozen period
$e(t)$	If error occurs $e(t)=1$ else 0
j,k,d,e	Value of $s(t),b(t),v(t),e(t)$ respectively
i	Index of the Access Category ACi i= 0, 1, 2,or 3
$A_i$	Value of AIFSI decreased by 1
N	Value of the initial frozen timer
$W_j$	Maximal value of the backoff timer
m	Number of maximum retry with $W_j$ increasing
m + h	Number of maximum retry before discarding the packet
$P_i(P_e)$	collision (error) probability for ACi
$P_b$	Probability that the channel is busy
q	Probability that the buffer isn't empty
$T_e, T_c$	time to detect an error,collision
$\gamma, T_s$	time for propagation, successful transmission

Table 4.1: Variables and constants of the model

transmit. This implies that the results represent the maximum throughput offered by a WiFi cell. However, this model uses several approximations. Firstly, the channel is supposed to be ideal, i.e., it does not introduce any error. Moreover, the limited number of retransmissions allowed in the standard is not taken into account in the model.

The first dimension  $s(t)$  indicates the backoff stage which represents the number of transmission attempts which failed. The second dimension  $b(t)$ , is a stochastic process indicating the state of the backoff timer, for a given AC at time t, all those dimensions were introduced by [16]. The initial value of the timer is drawn among an interval  $[0, W_j]$ , where  $W_j$  depends on the backoff stage  $j$  with  $W_{j+1} = 2W_j + 1$ . The third dimension introduced by [48] is a variable which has various meanings according to the context. During the frozen period, it indicates the remaining time before being able to carry on decreasing the timer. In transmission or collision period, it indicates the remaining time before the end of the period.

In our model, we introduce a fourth dimension, denoted by  $e(t)$ , such that  $e(t) = 1$  if the transmission is corrupted but did not undergo a collision and  $e(t) = 0$  otherwise. This variable was introduced in order to distinguish between a transmission failed because of a collision and that which fails because of an error. Let  $P_i$  be the collision probability and  $P_b$  the probability that the channel is busy. At time t, a state of a given  $AC_i$  is fully determined by the quadruplet (j, k, d, e) which corresponds to the values taken respectively by each dimension.

Let us describe the chain through some specific states. The system is in

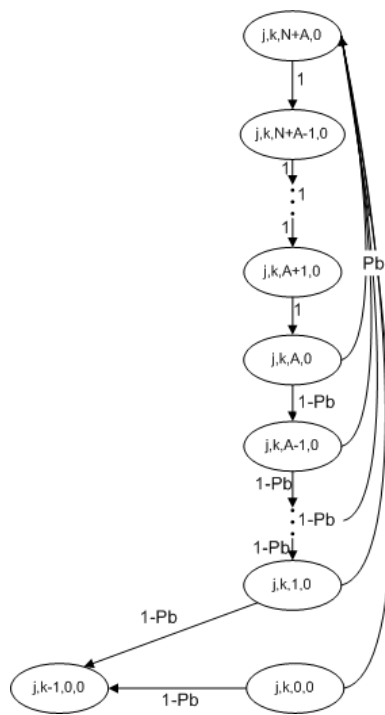

Figure 4.1: A Frozen Period

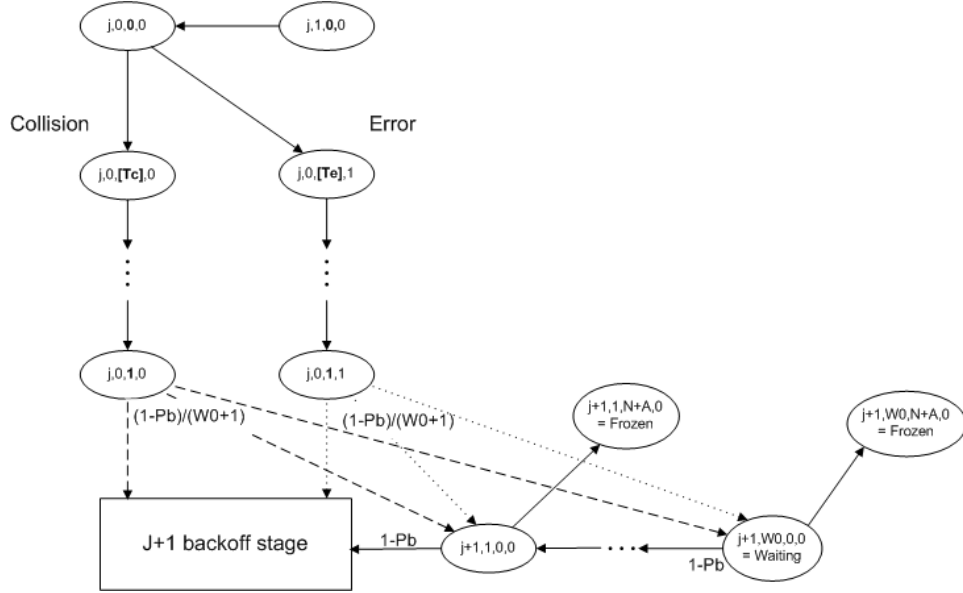

Figure 4.2: Collisions and Errors

the state  $j = -1$  in the case of post-backoff following a transmission (either successful or not);  $j = -2$  indicates that the  $AC_i$  is in the transmission period, after having reached the channel successfully, without having met collision, nor errors. The following states are specific to our model. Firstly, the unsaturated buffer is a key parameter of our model. Indeed, we consider either that a new packet may arrive, or that there is no standby packet in the buffer:  $j = -4$  indicates that the  $AC_i$  tries to transmit a packet lately arrived in the buffer, and  $j = -5$ , indicates that the buffer of the  $AC_i$  is empty.

#### 4.1.2 Markov Chain

We will now describe the chain starting from a given state and will observe the possible paths through the chain. Let us suppose that  $AC_i$  is in the state  $(j, 1, 0, 0)$ . Thus AC met  $j$  collisions and/or corrupted transmissions and undergoes its  $j^{th}$  backoff. This is indicated by the current value of the first dimension. Its backoff timer is equal to 1, as shown by the second dimension. The value of the third dimension which is equal to 0, indicates that the timer is currently decreasing.. Beside, since the  $j^{th}$  transmission has not yet begun, the 4<sup>th</sup> dimension is by default equal to 0. From that state,



two possibilities arise . If  $AC_i$  observes a busy channel, the backoff timer is frozen (see *Fig.4.1*), which involves the beginning of the frozen period, and brings  $AC_i$  to state  $(j, 1, N+A_i, 0)$ . Otherwise, the systems goes to  $(j, 0, 0, 0)$ . This cycle is repeated until  $AC_i$  can reactivate its timer and accesses the channel. At this point, if no higher priority  $AC_{i'}$  (within the same STA or another STA) tries to transmit at the same time,  $AC_i$  will access the channel and transmit its packet. However, if a collision or an error occurs, a certain time respectively  $T_c$  or  $T_e$  will be required before  $AC_i$  becomes aware of this collision or respectively of this error, and passes to state  $j+1$  for a new attempt.

### 4.1.3 Characteristic of Our Model: the Unsaturated Mode

After a successful transmission, if the buffer already has a new packet in standby (with a probability  $q$ ), then  $AC_i$  enters state  $j = -1$ . If the buffer is empty (with a probability  $1-q$ ),  $AC_i$  enters a waiting state noted  $(-5, 0, 0, 0)$ . In each Time Slot,  $AC_i$ , checks its buffer, if it still does not contain a new packet to be transmitted it remains in the same state  $(-5, 0, 0, 0)$ . On the other hand, if a new packet arrives in the queue, the  $AC_i$  moves to state  $(-4, 0, A_i, 0)$ , which allows it to access the channel directly after having checked that it remained free for a certain time ( $AIFS_i$ ).

This is a major difference with the saturated models that assume a STA always has a packet to transmit, in other words, that its buffer is never empty. Therefore, when a new packet arrives, it has to wait and initiate a backoff, instead of being sent directly after an AIFS. In our model, we introduced  $(-4,0,d,0)$ ,  $d=0..A_i$  to correct this approximation. The introduction of this state, namely  $(-5,0,0,0)$ , is fundamental, since a STA does not always have data to transmit. Thus, we can consider the possibility of having an empty buffer. In addition, compared to existing models, we add significant value by allowing to represent different load scenarios using parameter  $q$ .

### 4.1.4 Transition probabilities

We will now describe the transition probabilities from one state to another.

1. For states  $(-2, 0, d, 0)$ ,  $d = 1,2,\dots, [T_s]$ ,

- $$P\{(-2, 0, d - 1, 0)/(-2, 0, d, 0)\} = 1$$

$$2 \leq d \leq [T_s]$$

Account for the fact that, during the transmission, time is decremented.

- $P\{(-1, 0, A_i, 0)/(-2, 0, 1, 0)\} = q$

After a successful transmission, when a new packet is already waiting in the buffer

- $P\{(-5, 0, 0, 0)/(-2, 0, 1, 0)\} = 1 - q$

When the buffer is empty

2. For states  $(j, 0, 0, 0)$ ,  $j = 0, 1, \dots, m+h$ ,

- Successful transmission if no collision nor error occurs.

$$P\{(-2, 0, [T_s], 0)/(j, 0, 0, 0)\} = (1 - P_i)(1 - P_e)$$

$$0 \leq j \leq m + h$$

- If a collision occurs then  $AC_i$  enters the collision period

$$P\{(j, 0, [T_c], 0)/(j, 0, 0, 0)\} = P_i; 0 \leq j \leq m + h$$

- If no collision occurs but there is an error

$$P\{(j, 0, [T_e], 1)/(j, 0, 0, 0)\} = (1 - P_i) \times P_e; 0 \leq j \leq m + h$$

3. For state  $(m+h, 0, 0, 0)$ ,

- If no collision and no error occurs, then the transmission succeed

$$P\{(-2, 0, [T_s], 0)/(m + h, 0, 0, 0)\} = (1 - P_i)(1 - P_e)$$

- If a collision or an error occurs after the collision or error period, the packet is discarded because  $m+h$  retries have been exhausted.

Then the  $AC_i$  checks his buffer. If a new packet is already waiting:

- After an error:

$$P\{(-1, 0, A_i, 0)/(m + h, 0, 1, 1)\} = (1 - P_i)P_e \times q$$

- After a collision:

$$P\{(-1, 0, A_i, 0)/(m + h, 0, 1, 0)\} = P_i \times q$$

Let:

$$P_i + (1 - P_i)P_e = P_{fi} \quad (4.1)$$

If the buffer is empty:

- After an error:

$$P\{(-5, 0, 0, 0)/(m + h, 0, 1, 1)\} = (1 - P_i)P_e \times (1 - q)$$

- After a collision:

$$P\{(-5, 0, 0, 0)/(m + h, 0, 1, 0)\} = P_i \times (1 - q)$$

4. For states  $(j, 0, d, 0)$ ,  $j = 0, 1 \dots m+h$  and  $d \geq 1$ , when a collision occurs, time is decremented by 1 for each time slot elapsed, until the  $AC_i$  exits the collision period:

$$P\{(j, 0, d - 1, 0)/(j, 0, d, 0)\} = 1$$

$$0 \leq j \leq m + h; \quad 2 \leq d \leq [T_c]$$

When the collision period finishes, the  $AC_i$  doubles the size of the Contention Window (CW), except when CW had already reached the maximum value CWmax, and chooses a random number from the uniformly distributed set  $[0, W_{j+1}]$  and then enters the next backoff stage

$$P\{(j + 1, k, 0, 0)/(j, 0, 1, 0)\} = \frac{1}{(W_{j+1} + 1)}$$

$$0 \leq k \leq W_{j+1}; \quad 0 \leq j \leq m + h$$

5. For states  $(j, 0, d, 1), j = 0, 1, \dots, m+h$  and  $d \geq 1$ , it is similar to the collision period and time is still decremented by 1:

$$P\{(j, 0, d-1, 1)/(j, 0, d, 1)\} = 1$$

$$0 \leq j \leq m+h; \quad 2 \leq d \leq [T_e]$$

$$P\{(j+1, k, 0, 0)/(j, 0, 1, 1)\} = \frac{1}{(W_{j+1} + 1)}$$

$$0 \leq k \leq W_{j+1}; \quad 0 \leq j \leq m+h$$

6. For states  $(j, k, 0, 0), j = 0, 1, \dots, m+h$  and  $k \geq 1$ , the backoff timer is decremented by 1 if the channel is idle,

$$P\{(j, k-1, 0, 0)/(j, k, 0, 0)\} = 1 - P_b$$

$$1 \leq k \leq W_j; \quad 0 \leq j \leq m+h$$

It is frozen if the channel is busy and has to wait  $N+A_i$  Time Slots

$$P\{(j, k, N+A_i, 0)/(j, k, 0, 0)\} = P_b$$

$$1 \leq k \leq W_j; \quad 0 \leq j \leq m+h$$

7. For states  $(j, k, d, 0), j = 0, 1, \dots, m+h, \quad k \geq 1$  and  $d \geq 1$ , when a time slot elapsed during the frozen period, the remaining frozen time is decremented by 1

$$P\{(j, k, d-1, 0)/(j, k, d, 0)\} = 1$$

$$1 \leq k \leq W_j; \quad 0 \leq j \leq m+h; \quad A_i + 1 \leq d \leq N + A_i$$

After the frozen period, if the channel is idle, the backoff time is further decremented

$$P\{(j, k, d - 1, 0)/(j, k, d, 0)\} = 1 - P_b$$

$$1 \leq k \leq W_j; \quad 0 \leq j \leq m + h; \quad 2 \leq d \leq A_i$$

$$P\{(j, k - 1, 0, 0)/(j, k, 1, 0)\} = 1 - P_b;$$

$$1 \leq k \leq W_j; \quad 0 \leq j \leq m + h.$$

But if the channel is still busy, then the frozen time returns to its initial value, i.e.,  $N + A_i$ .

$$P\{(j, k, N + A_i, 0)/(j, k, d, 0)\} = P_b$$

$$1 \leq k \leq W_j; \quad 0 \leq j \leq m + h; \quad 1 \leq d \leq A_i,$$

8. For states  $(-1, 0, d, 0)$ ,  $d = 0, 1, \dots, N + A_i$ , before transmitting the packet, the channel has to be idle during an  $AIFS_i$  time. If it is still idle, then the backoff process is started. If not the frozen period is initiated.

$$P\{(-1, 0, d - 1, 0)/(-1, 0, d, 0)\} = 1; A_i + 1 \leq d \leq N + A_i$$

$$P\{(-1, 0, d - 1, 0)/(-1, 0, d, 0)\} = 1 - P_b; 1 \leq d \leq A_i$$

$$P\{(-1, 0, N + A_i, 0)/(-1, 0, d, 0)\} = P_b; 0 \leq d \leq A_i$$

$$P\{(0, k, 0, 0)/(-1, 0, 0, 0)\} = \frac{1 - P_b}{W_0 + 1}; 0 \leq k \leq W_0$$

9. For states  $(-4, 0, d, 0)$ ,  $d = 0, \dots, A_i$ , the new packet is already available. If the channel is idle, the packet is directly transmitted without going through the backoff process, since it is a new packet which is not

following a last transmission. In case of a busy channel, the backoff process is initiated

$$P\{(-4, 0, d - 1, 0)/(-4, 0, d, 0)\} = 1 - P_b; 1 \leq d \leq A_i$$

$$P\{(0, 0, 0, 0)/(-4, 0, 0, 0)\} = 1 - P_b$$

$$P\{(-1, 0, N + A_i, 0)/(-4, 0, d, 0)\} = P_b; 0 \leq d \leq A_i$$

10. For state  $(-5, 0, 0, 0)$ , if the buffer is empty, then the  $AC_i$  waits until a packet arrives, and then initiates the regular contention process through state  $(-4, 0, A_i, 0)$ .

$$\begin{aligned} P\{(-5, 0, 0, 0)/(-5, 0, 0, 0)\} &= 1 - q \\ P\{(-4, 0, A_i, 0)/(-5, 0, 0, 0)\} &= q \end{aligned}$$

#### 4.1.5 Probability in steady state and equation systems

Let  $b_{j,k,d,e}$  be the probability to be in state  $(j,k,d,e)$ , when the system is steady (in other words when  $t \rightarrow +\infty$ ). As mentioned previously,  $P_{fi}$  stands for the probability of a failed transmission, due to collision or error.

In the following, all the probabilities  $b_{j,k,d,e}$  have to be indexed to  $i$  the index of the access categories  $AC_i$  and thus have to be read as  $b_{j,k,d,e_i}$ . For purpose of readability we omit the index in further calculations.

We calculated those probabilities using the same methodology as [16] and [48], but it was naturally necessary to adapt the equations and calculations to the requirements and states of our model.

We obtained:

$$\begin{aligned} b_{j,0,0,0} &= (P_{fi})^j \times b_{0,0,0,0} \\ 0 &\leq j \leq m + h \end{aligned} \tag{4.2}$$

$$\begin{aligned}
b_{0,k,0,0} &= \binom{W_0 - k + 1}{1} \times \frac{1}{W_0 + 1} \left[ (1 - P_b)b_{-1,0,0,0} + P_b \sum_{d=0}^A b_{-4,0,d,0} \right] \\
&= \frac{W_0 - k + 1}{W_0 + 1} \left[ \frac{(1 - P_b)q}{(1 - P_b)} + P_b \sum_{d=0}^A (1 - q)(1 - P_b)^{A-d} \right] \\
&= \frac{W_0 - k + 1}{W_0 + 1} \left[ q + P_b(1 - q) \sum_{d=0}^A (1 - P_b)^{A-d} \right] \\
&= \frac{W_0 - k + 1}{W_0 + 1} \left[ q + P_b(1 - q) \frac{1 - (1 - P_b)^{A+1}}{P_b} \right] \\
&= \frac{W_0 - k + 1}{W_0 + 1} \\
&\quad \times (1 - (1 - q)(1 - P_b)^{A+1}) \\
&\quad \times b_{0,0,0,0} \\
&\quad 1 \leq k \leq W_j
\end{aligned} \tag{4.3}$$

$$\begin{aligned}
b_{j,k,0,0} &= \frac{W_j + 1 - k}{W_j + 1} \cdot b_{j,0,0,0} \\
&\quad 1 \leq j \leq m + h; \quad 0 \leq k \leq W_j
\end{aligned} \tag{4.4}$$

For the third dimension, due to the regularity of the Markov chain, we get:

$$\begin{aligned}
b_{j,k,d,0} &= \frac{P_b}{(1 - P_b)^A} \times b_{j,k,0,0} \\
A_i \leq d \leq N + A_i; \quad 0 \leq j \leq m + h; \quad 1 \leq k \leq W_j
\end{aligned} \tag{4.5}$$

$$\begin{aligned}
b_{j,k,d,0} &= \frac{P_b}{(1 - P_b)^d} \times b_{j,k,0,0}, \\
1 \leq d \leq A_i - 1; \quad 0 \leq j \leq m + h; \quad 1 \leq k \leq W_j
\end{aligned} \tag{4.6}$$

$$\begin{aligned}
b_{j,0,d,0} &= P_i \times b_{j,0,0,0}, \\
1 \leq d \leq [Tc]; \quad 0 \leq j \leq m + h
\end{aligned} \tag{4.7}$$

$$\begin{aligned}
b_{j,0,d,1} &= (1 - P_i) \times P_e \times b_{j,0,0,0} \\
1 \leq d \leq [Te]; \quad 0 \leq j \leq m + h
\end{aligned} \tag{4.8}$$

$$b_{-2,0,d,0} = (1 - P_{fi}^{m+h+1}) \times b_{0,0,0,0} \quad (4.9)$$

$$1 \leq d \leq [Ts]$$

$$b_{-1,0,d,0} = b_{0,0,0,0} \times \frac{1}{(1 - P_b)^{d+1}} - \frac{1 - q}{(1 - P_b)^{d-A_i}} \quad (4.10)$$

$$0 \leq d \leq A_i$$

$$b_{-1,0,d,0} = b_{0,0,0,0} \times \frac{1 - (1 - P_b)^{A_i+1}}{(1 - P_b)^{A_i+1}} \quad (4.11)$$

$$A_i+1 \leq d \leq N + A_i$$

And for state (-5, 0, 0, 0)

$$b_{-5,0,0,0} = \frac{(1 - q) \times b_{0,0,0,0}}{q} \quad (4.12)$$

$$b_{-4,0,d,0} = (1 - P_b)^{A_i-d} \times (1 - q) \times b_{0,0,0,0} \quad (4.13)$$

$$0 \leq d \leq A_i$$

By substituting (4.2) into (4.4), and (4.4) into (4.5)-(4.8), all the probabilities  $b_{j,k,d,e}$  can be derived from  $P_{bi}, P_i, P_e, q$ , which respectively stand for the probability that the channel is busy, the probability of collision for  $AC_i$ , the packet error rate, and the probability that the buffer is not empty.

Finally we derive  $b_{0,0,0,0}$  from the normalization condition. This condition is a straightforward consequence of the fact that state that in each given time an  $AC_i$  is necessarily in one of the state of the Markov Chain thus the probability to be in one of the state of the Markov Chain is equal to 1. This probability correspond to the sum of all the steady state just presented above. Thus we have:

$$1 = b_{-5,0,0,0} + \sum_{d=1}^{T_s} b_{-2,0,d,0} + \sum_{d=0}^A b_{-4,0,d,0} + \sum_{d=0}^{N+A} b_{-1,0,d,0}$$

$$+ \sum_{j=0}^{m+h} \sum_{d=0}^{T_c} b_{j,0,d,0} + \sum_{j=0}^{m+h} \sum_{d=1}^{T_e} b_{j,0,d,1} + \sum_{j=0}^{m+h} \sum_{k=1}^{W_j} \sum_{d=0}^{N+A} b_{j,k,d,0}$$

We will now detail the derivation of each of the element of this equation which leads to the derivation of  $b_{0,0,0,0}$ .



$$\sum_{d=1}^{T_s} b_{-2,0,d,0} = T_s(1 - p_{f_i}^{m+h+1})b_{0,0,0,0}$$

easily observed directly from the Markov Chain and (4.9).

$$\begin{aligned} & \sum_{j=0}^{m+h} \sum_{d=0}^{T_c} b_{j,0,d,0} \\ &= \sum_{j=0}^{m+h} \sum_{d=1}^{T_c} b_{j,0,0,0} + \sum_{j=0}^{m+h} b_{j,0,0,0} \text{ first term derived from (4.7)} \\ &= b_{0,0,0,0}(T_c P_i + 1) \sum_{j=0}^{m+h} p_{f_i}^j \text{ given by (4.2)} \\ &= b_{0,0,0,0}(p_i T_c + 1) \frac{1 - p_{f_i}^{m+h+1}}{1 - p_{f_i}} \end{aligned}$$

In a very similar way, we compute:

$$\sum_{j=0}^{m+h} \sum_{d=1}^{T_e} b_{j,0,d,1} = b_{0,0,0,0}((1 - p_i)p_e T_e) \frac{1 - p_{f_i}^{m+h+1}}{1 - p_{f_i}}$$

Then, we compute

$$\begin{aligned} \sum_{d=0}^{N+A} b_{-1,0,d,0} &= \sum_{d=0}^A b_{-1,0,d,0} + \sum_{d=A+1}^{N+A} b_{-1,0,d,0} \\ &= q \left[ \frac{1 - (1 - P_b)^{A+1}}{P_b(1 - P_b)^{A+1}} + \frac{N(1 - (1 - P_b)^{A+1})}{(1 - P_b)^{A+1}} \right] \times b_{0,0,0,0} \text{ with help of (4.10) and (4.11)} \\ &= q \left[ \frac{1 + NP_b}{P_b} \frac{1 - (1 - P_b)^{A+1}}{1 - P_b} \right] \times b_{0,0,0,0} \end{aligned}$$

And,

$$\begin{aligned}
\sum_{j=0}^{m+h} \sum_{k=1}^{W_j} \sum_{d=0}^{N+A} b_{j,k,d,0} &= \sum_{j=0}^{m+h} \sum_{k=1}^{W_j} \left( b_{j,k,0,0} + \sum_{d=1}^A \frac{P_b}{(1-P_b)^d} b_{j,k,0,0} + \sum_{d=A}^{N+A} \frac{P_b}{(1-P_b)^A} b_{j,k,0,0} \right) \\
&= \sum_{j=0}^{m+h} \sum_{k=1}^{W_j} b_{j,k,0,0} \left( 1 + \frac{1 - (1-P_b)^{A-1}}{(1-P_b)^{A-1}} + \frac{(N+1)P_b}{(1-P_b)^A} \right) \\
&= \frac{1 + NP_b}{(1-P_b)^A} \left( \sum_{k=0}^{W_j} b_{0,k,0,0} + \left( \sum_{j=1}^{m+h} b_{j,0,0,0} \sum_{k=1}^{W_j} \frac{W_j + 1 - k}{W_j + 1} \right) \right) \\
&= \frac{1 + NP_b}{(1-P_b)^A} \left( [1 - (1-q)(1-P_b)^{A+1}] \cdot b_{0,0,0,0} \frac{W_0}{2} + \sum_{j=1}^{m+h} b_{j,0,0,0} \frac{W_j}{2} \right) \\
&= \frac{1 + NP_b}{2(1-P_b)^A} \left( [1 - (1-q)(1-P_b)^{A+1}] \cdot W_0 + \sum_{j=1}^{m+h} W_j P_{f_i}^j \right)
\end{aligned}$$

And last,

$$\sum_{d=0}^A b_{-4,0,d,0} = b_{0,0,0,0}(1-q) \sum_{d=0}^A (1-P_b)^{A-d} = b_{0,0,0,0}(1-q) \frac{1 - (1-P_b)^{A+1}}{P_b}$$

Finally we get:

$$\frac{1}{b_{0,0,0,0}} = \left[ \begin{aligned} &\frac{1-q}{q} + [Ts](1 - (P_{f_i})^{m+h+1}) \\ &+ (1-q) \left( \frac{1 - (1-P_b)^{A_i+1}}{P_b} \right) \\ &+ \frac{1 - (1-P_b)^{A_i+1}}{P_b} \left[ \frac{1}{(1-P_b)^{A_i+1}} - (1-q) \right] + N \frac{1 - (1-P_b)^{A_i+1}}{(1-P_b)^{A_i+1}} \\ &+ ([Tc]P_i + 1) \left( \frac{1 - P_{f_i}^{m+h}}{1 - P_{f_i}} \right) \\ &+ ([Te](1 - P_i)P_e) \left( \frac{1 - P_{f_i}^{m+h}}{1 - P_{f_i}} \right) \\ &+ \frac{1 + NP_b}{2(1-P_b)^{A_i}} \left( [1 - (1-q)(1-P_b)^{A_i+1}] \times W_0 \right) \\ &+ \sum_{j=1}^{m+h} W_j P_{f_i}^j + P_{f_i}^{m+h} \end{aligned} \right]$$

Thus, to derive  $b_{0,0,0,0}$  we have must get the values of  $T_s, T_c, T_e, P_b, P_i, P_e, m, h, W_j, A_i, N$ , and  $q$ .

The derivation of  $T_s, T_c$ , and  $T_e$  will be explained below, in section 4.2. The parameters  $m, h, A_i, N, W_j$  are characteristics of the  $AC_i$ . For example,  $W_j$  depends on its initial value  $W_0$  (also denoted  $CW_{min}$ ), which is a variable that differs from an  $AC_i$  to another one. The values of  $P_e$  depend on the transmission environment.

Let  $\tau_i$  be the probability that an  $AC_i$  accesses a channel. It corresponds to the sum of the probabilities to be in one of the final states of backoff, which allow transmitting on the medium, then:

$$\begin{aligned}\tau_i &= \sum_{j=0}^{m+h} b_{j,0,0,0_i} = \sum_{j=0}^{m+h} P_{f_i}^j \times b_{0,0,0,0_i} \\ &= \frac{1 - P_{f_i}^{m+h+1}}{1 - P_{f_i}} b_{0,0,0,0_i}\end{aligned}$$

Given that a STA includes 4  $AC_i$ , the probability that a STA transmits equals the probability that at least one of the  $AC_i$  transmits, so:

$$\tau = 1 - \prod_{i=1}^3 (1 - \tau_i) \quad (4.14)$$

Considering that the channel is occupied by the  $AC_i$ , if and only if the transmission, collision or error is related to this  $AC_i$ . Let  $v_i$  be the probability that the channel is occupied by  $AC_i$

$$v_i = \sum_{d=1}^{[T_s]} b_{-2,0,d,0} + \sum_{j=0}^{m+h} \sum_{d=0}^{[T_c]} b_{j,0,d,0} + \sum_{j=0}^{m+h} \sum_{d=1}^{[T_e]} b_{j,0,d,1} \quad (4.15)$$

Then :

$$\begin{aligned}v_i &= b_{0,0,0,0_i} \times (1 - P_{f_i}^{m+h+1}) \\ &\quad \times \left( T_s + \frac{P_i \times T_c + (1 - P_i) p_e \times T_e + 1}{1 - P_{f_i}} \right) \quad (4.16)\end{aligned}$$

And  $v$  the probability that the channel is occupied by a station

$$v = 1 - \prod_{i=1}^3 (1 - v_i). \quad (4.17)$$

The probability that the channel is busy is given by:

$$P_b = 1 - (1 - \nu)^M \quad (4.18)$$

M stands for the total number of active stations. The collision probability is given by the probability that at least one other STA transmits at the same time (called external collision) or an other  $AC_{i'}$  in the same STA (virtual internal collision).

$$P_i = 1 - (1 - \tau)^{M-1} \times \prod_{i' > i} (1 - \tau_{i'}) \quad (4.19)$$

$$(4.20)$$

And if we substitute by (4.14), we get:

$$P_i = 1 - \prod_{j=0}^3 (1 - \tau_j)^{M-1} \prod_{j=i+1}^3 1 - \tau_j \quad (4.21)$$

where  $i'$  means that  $AC_{i'}$  has a higher priority than  $AC_i$ .

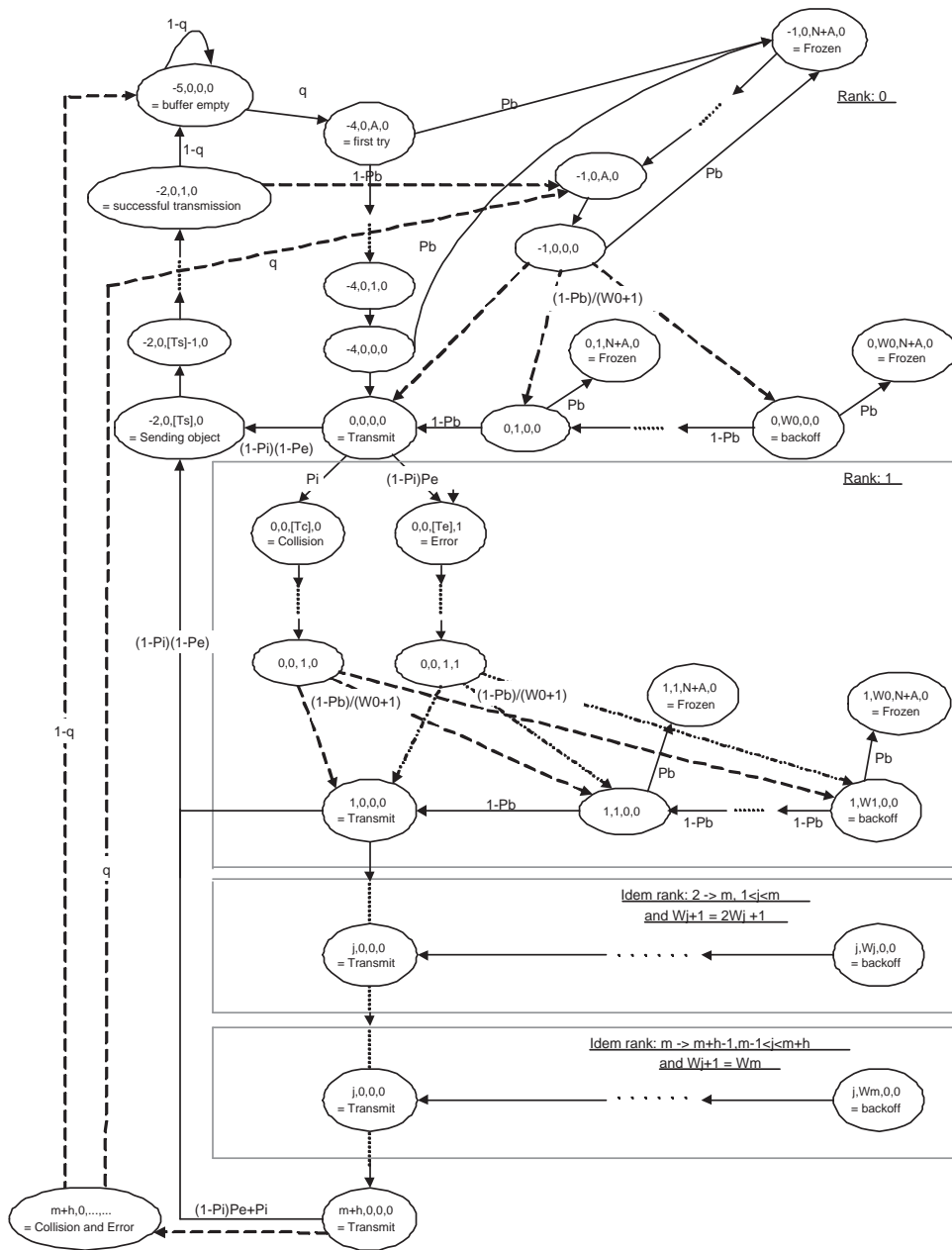

Figure 4.3: The full Markov chain

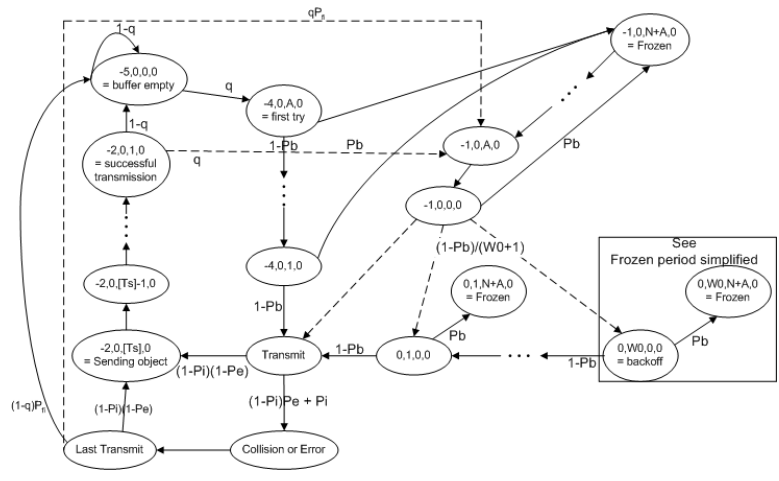

Figure 4.4: Simplified Markov Chain

## 4.2 Throughput derivation

The standardized throughput for a given AC is derived as the ratio between the effective time to transmit the data and the average time between two successive transmissions. This average time takes into account the time spent in the contention process, the time possibly wasted in collision and/or error as well as time to successfully transmit the packet, including transmission times of the protocol overheads.

Let  $S_i$  be the throughput for the  $AC_i$

$$S_i = \frac{P_{si}P}{E[I] + \sum_{i'=0}^3 P_{si'}(T_s + AIFS[AC_{i'}]) + \sum_{i'=0}^3 P_{i'}T_c + P_eT_e}$$

Where  $P$  stands for the data payload and  $E[I]$  is the average time where the channel is idle. We have:

$$E[I] = \frac{1}{P_b} - 1$$

$P_{si}$  and  $P_{si'}$  correspond to the probability that the transmission succeeds resp. for  $AC_i$  and  $AC_{i'}$  derived from [48].

$P_{si}$  is given by the following:

With

$$P_{si} = \frac{M \times P_{ti}(1-v)^{M-1} \times \prod_{i'>i}(1-v_{i'})}{1 - (1-v)^M}$$

$$P_{ti} = Ts \times b_{0,0,0,0_i} \times (1 - (P_{fi})^{m+h+1})$$

For  $T_s, T_c,$  and  $T_e,$  we use the values given by the standard [4].

Below, we give the equations to calculate each of those times.

$$T_{sb} = PHYheader + MACheader + Tp + \gamma$$

$$+ SIFS + ACK + \gamma$$

$$T_{eb} = T_{sb}$$

$$T_{cb} = PHYheader + MACheader + Tp + \gamma$$

$$+ ACK + SIFS$$

And for the RTS/CTS mode:

$$\begin{aligned}
T_{s_r} &= RTS + \gamma + SIFS + CTS + \gamma \\
&\quad + SIFS + PHYheader + MACheader \\
&\quad + Tp + \gamma + SIFS + ACK + \gamma \\
T_{e_r} &= T_{s_r} \\
T_{c_r} &= RTS + \gamma + SIFS + CTS + \gamma \\
&\quad + SIFS
\end{aligned}$$

Where  $Tp$  stands for the payload's transmission time which obviously depends on the nominal throughput  $R$  (e.g.: 11 Mbps for 802.11b).

### 4.3 Delay derivation

In this section we compute the delay encountered by a single station. By delay we mean the amount of time required from the moment the packet arrive at the top of the buffer till it's successfully transmitted. By successful transmission we assume also the reception of an ACK. This later supplementary time period is taken into account in the  $T_{s_b}$  (or  $T_{s_r}$ ) time computed above. As our model extends the one developed by [48], the way we compute the delay is naturally similar. However, because we have an additional dimension, some other states have to be accounted for in the final calculation. The delay is computed in a recursive manner. For instance the delay at state  $(j, k, d, e)$  denoted  $D_{j,k,d,e}$  stands for the delay the sta waits from the time the packet was delivered at the top of the buffer till it arrives at state  $(j, k, d, e)$ . For example to compute the delay  $D_{j,k,A+1,0}$ , we know that the transition probability from state  $D_{j,k,A,0}$  is 1. Thus we can state that  $D_{j,k,A,0} = D_{j,k,A+1,0} + 1$ , in other words the delay at state  $(j, k, A, 0)$  is equal to the delay accumulated at  $(j, k, A + 1) + 1$ . As the probability to arrive at a given states is sometimes more complex as we saw in 4.1.4, the delay in respectively more complex. We assume in the following that all steady state probabilities are known and computed as in 4.1.5. If we assume  $D_{j,k-1,d,e}$  is known, the relationships between states  $(j, k - 1, 0, e)$  and  $(j, k, d, e)$  when  $d = 0, 1, 2, \dots, N + A$ , are



$$\begin{aligned}
D_{j,k,d,e} &= (1 - P_b)D_{j,k-1,0,e} + P_b D_{j,k,N+A,0} + 1, & d = 0, 1 \\
D_{j,k,d,e} &= (1 - P_b)D_{j,k,d-1,e} + P_b D_{j,k,N+A,0} + 1, & 2 \leq d \leq A \\
D_{j,k,d,e} &= D_{j,k,d-1,0} + 1, & A + 1 \leq d \leq A + N
\end{aligned}$$

For the states  $(j, 0, 0, e)$ ,  $0 \leq j \leq m + h - 1$ , the transmission is either a successful transmission or a collision, error. Thus, the delay  $D_{j,0,0,0}$  is expressed as

$$\begin{aligned}
D_{j,0,0,e} &= P_i(D_{j,0,[T_e],0} + 1) + (1 - P_i) \\
&\quad + (1 - P_i)P_e(D_{j,0,[T_e],1} + 1) \\
&\quad + 1 - [(1 - P_i)P_e], \quad 0 \leq j \leq m + h - 1.
\end{aligned}$$

where  $D_{j,0,[T_e],0}$  or  $D_{j,0,[T_e],1}$  is obtained from the following relations. For states  $(j, 0, d, e)$ ,  $d = 0, 1, \dots, [T_e]$  we have

$$D_{j,0,d,e} = D_{j,0,d,e} + 1 \quad 2 \leq j \leq [T_e]$$

The delays of the initial states  $(-1, 0, d, e)$ ,  $d = 0, 1, \dots, A + N$ , are given by

$$\begin{aligned}
D_{-1,0,0,e} &= (1 - P_b) \sum_{k=0}^{W_0} \frac{D_{0,k,0}}{W_0 + 1} + 1 \\
D_{-1,0,d,e} &= (1 - P_b)D_{-1,0,d-1,e} + P_b D_{-1,0,N+A,0} + 1, \quad 1 \leq d \leq A \\
D_{-1,0,d,e} &= D_{-1,0,d-1,0} + 1, \quad A + 1 \leq d \leq A + N
\end{aligned}$$

The time required in order to send the packet successfully when  $j = m + h$  is 1. Otherwise he will be thrown. So,

$$D_{m+h,0,0,0} = 1$$

$$\begin{aligned}
D &= \sum_{d=0}^{N+A} b_{-1,0,d,0} D_{-1,0,d} + \sum_{j=0}^{M+h} \sum_{d=0}^{[T_c]} b_{j,0,d,0} D_{j,0,d,0} \\
&+ \sum_{j=0}^{m+h} \sum_{d=0}^{[T_c]} b_{j,0,d,0} D_{j,0,d,0} + \sum_{j=0}^{m+h} \sum_{k=0}^{W_i} \sum_{d=0}^{N+A} b_{j,k,d} D_{j,k,d,0}
\end{aligned}$$

## Chapter 5

# Frequency allocation to femtocell a double frequency reuse assignment scheme

As the radio resources become more and more scarce the spectrum sharing approach is more attractive. However as the interference mitigation problem is so challenging, spectrum splitting seems more realistic. We propose here to mix the two approaches via a frequency reuse between macrocell and femtocell.

### 5.1 Double Frequency Reuse: A novel Channel Allocation Scheme for Femtocells

We assume that at the macrocell level we have a classical frequency reuse e.g. 3/3 frequency reuse scheme where each macrocell is split into three adjacent sector through directional antennas. We propose a "double" frequency reuse scheme where femtocells located in a given macrocell sector will be allowed to reuse the bandwidth of the two other adjacent sectors of the same overlying macrocell. In this way we increase spectrum efficiency and meanwhile mitigate cross-tier interferences that could occur between macrocell and femtocell users camping on the same spectrum. Let us consider a system with an overall available bandwidth  $B$ . We split the spectrum into three equal parts, one for each of the three sectors of each MAP. This scheme is known as 1\*3\*3 reuse scheme also considered by the WiMax Forum. We consider here a scenario with 7 macrocells, see Fig. 5.1. A three-sector clover-leaf

cellular layout is used. We use 3 colors: B: Blue, R: Red and G: Green to represent the 3 parts of the split spectrum. For each sector, we allow the femtocells in it to reuse the spectrum not used by its MAP (i.e. two-thirds of the available bandwidth). We propose three kinds of reuse plans:

- Full reuse: The simplest reuse plan is full reuse over the whole area. This means that wherever the femtocell is located on the area of its sector it can reuse whatever frequency used by the two adjacent sectors. The selection by each femtocell of a specific frequency among those spectra will be detailed in section 5.2. The advantage of this reuse method is that more channels are available for femtocells, thus more flexibility to mitigate inter-femtocell interferences. The drawback of this method is that problems might occur when the FAP is close to the edge of the sector. Assume that the FAP chooses the same frequency that the adjacent macrocell sector, then it can suffer from Macrocell interference of the sector using the same spectrum in the adjacent cell in downlink, and vice versa "attack" the macrocell uplink as we explained in section 3.3.
- Partial reuse: The second method to share the spectrum of the adjacent sectors between FAPs is to split the sector into 6 equal parts considering our example but without loss of generality. Then we allocate to each part, the spectrum that is not used by the nearest sector of the adjacent cell. We avoid here the problem induced by the full reuse scheme but on the other hand the pool of frequencies that can be chosen by neighboring femtocells is reduced. This can lead to severe co-tier interference in case of a dense femtocell population.
- Mixed reuse: In this third method we try to find a tradeoff which helps us in keeping the advantages of the two previous methods. We define the central region where both adjacent sectors spectra can be used as in the full reuse, and the cell boundary region where, as in partial reuse method, only the spectrum not used by the nearest sector can be used. For this method we can define the radius of the central region in a static or dynamic manner. For the dynamic radius we have to use an algorithm that computes it, based on statistics of interference of Macro-to-Femto and vice-versa, at the boundary. If interference decreases, e.g. because of less loaded MAP edge, then we can extend the central region.

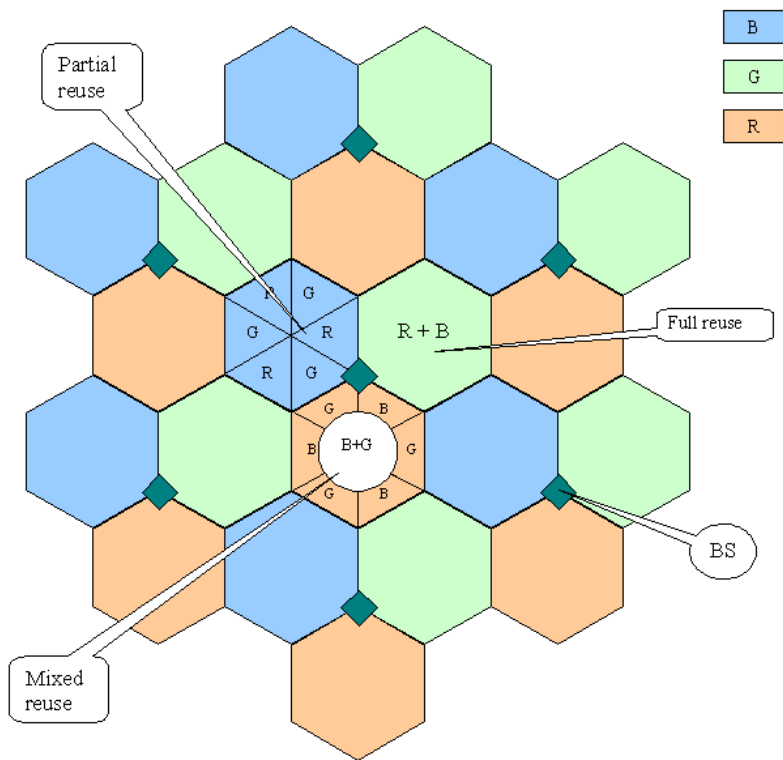

Figure 5.1: Frequency reuse scheme

## 5.2 Femtocell's Channel Selection

In this section we deal with the issue of sharing radio resources among the FAPs. Even though at the macrocell level, resource allocation can be scheduled by some complex central algorithm, the femtocell specifications require an auto-configuration mechanism. Given the large number of femtocells that could be deployed in a given area, especially in an urban environment, and the lack of a central coordinator a priori, channel assignments seem to be very complex. To avoid transmitting large amounts of information to a centralized scheduler and to avoid complexity issues from the processing of large amounts of information, we need to use an auto-configuration mechanism. This issue is currently under intensive research and standardization efforts under the terms such as: Spectrum Sensing, Cognitive Radio and Self Organizing Networks . We propose here a simple approach. The FAP senses the available spectrum and selects the subchannels that are not currently being used, if there are such subchannels. Then it sends to the user the list of the subchannels and the user senses each of them for a given time and then sends a feedback through Channel State Information (CSI) report for each subchannel. The subchannels which offer the best channel condition in terms of SINR is then chosen by the FAP. If no free subchannel is available, the FAP selects the least interfered subchannel, i.e. the subchannel in which the Received Signal Strength (RSS)(of the interference signals) is the lowest. It can ensure that the future transmission wont degrade the ongoing transmission. In this case, we could also take into account load statistics of each subchannel to improve the selection since a lightly loaded subchannel could perform better than a heavily loaded channel but with higher RSS. We assumed here that all the subchannels have equal bandwidth. However it might not be the case and thus channel selection may be more complex.

## 5.3 Other Fundamentals Parameters

In this section we deal with some other parameters we have to take into account in our proposal. For instance, we have to define what radio resource granularity will be considered in our model, as it could have some implications on the results. Moreover for the deployment scenarios considered, the transmission power at both the macro and femto level are fundamental parameters also have to be defined. Finally channel models and access control to the femtocell are detailed.

### 5.3.1 Radio Resource Granularity

Before starting the process of channel selection as presented in the section 5.1 we must define what will be the resource forming a channel or in other words, given the spectrum that can be reused by femtocells, how much of it will be granted to each femtocell.

The transmission technique we consider is OFDM, and the multiple access technique is OFDMA. Thus a resource unity is defined as a set of subcarriers over a given time period. This also referred as Resource Block (RB) in LTE. We assume here the use of FDD although TDD is also defined by 3GPP LTE.

The granularity is defined both on frequency and time domains but we do not consider here the latter. We explain in the next paragraph what motivate this consideration .

We will describe in the following the tradeoff involved in the granularity of the frequency domain.

Available subcarriers may be grouped into subchannels. This division (number of subcarriers per subchannel) is not easy to define.

On the one hand the more subcarriers per channel, the more bandwidth available to each femtocell and thus the more available capacity per user. In this case the femtocell can benefit from frequency diversity which leads to more efficient communications, especially if subcarriers composing a channel are spread out over the entire bandwidth a.k.a distributed subcarrier permutation (see further).

On the other hand, with fewer subcarriers per channel more channels are made available for different femtocell and thus there will be less cochannel interference between femtocells, as each one will be able to get its own subchannel which will be orthogonal to the others. However in this case, the sensibility to frequency offset will be higher than in the previous case and will require strong frequency synchronization, because the frequency distance between two subchannels will be smaller. Moreover the OFDM diversity gain, and resistance to frequency-selective fading, may partly be lost if very few sub-carriers are assigned to each user, and if the same carrier is used in every OFDM symbol [12]. Adaptive sub-carrier assignment based on fast feedback information about the channel, and/or sub-carrier frequency hopping, is therefore desirable. In addition, flexible allocation of subchannels can be used to dynamically allocate bandwidth to individual users for various bit rate services

In brief, we must consider the following questions:

1. How many subcarriers will be allocate to each sub channel?

2. will these subcarriers be contiguous or distributed over the whole available spectrum?
3. How many subchannel will be allocated to each user?
4. Will these allocations be dynamic or static?

In fact the issue of "subchannelization" i.e. number of subcarriers per subchannel and resource allocation i.e. number of subchannel per user is to be considered as a full problem and is beyond the scope of our proposition. Thus we will content ourselves with a simple approach where the number of subcarriers per subchannel will be fixed and equal for each subchannel, and the number of subchannels per user will also be fixed and equal for each user.

### **Distributed or Contiguous Subcarriers Allocation**

Subchannels may be constituted using either contiguous subcarriers or subcarriers pseudorandomly distributed across the frequency spectrum. Subchannels formed using distributed subcarriers provide more frequency diversity, which is particularly useful for mobile applications. The subchannelization scheme based on contiguous subcarriers is called (in WiMAX) Adaptive Modulation and Coding (AMC). Although frequency diversity is lost, AMC allows system designers to exploit multiuser diversity, allocating subchannels to users based on their frequency response. Multiuser diversity can provide significant gains in overall system capacity, if the system strives to provide each user with a subchannel that maximizes its received SINR. In general, contiguous subchannels are more suited for fixed and low-mobility applications.

Besides an advantage of contiguous allocation is the reduction of Adjacent Channel Interference (ACI). This is particularly relevant if each subcarrier bandwidth is small. It is a meaningful advantage of contiguous allocation since ACI is likely to happen at the femtocell level as very close coexistence between users of different cells can occur.

### **Time domain granularity**

We describe here briefly the issue of time domain granularity for femtocell.

In a very bad environment, frequency diversity could be critical. But as mentioned if the femtocells population is dense lack of sufficient channels would lead to strong cochannel interference. In such a case it could be



interesting to share the resource also on a time basis, i.e. the resource unity to be granted to each femtocell will not be based only on subcarriers but also on time unity of resource use. An obvious drawback of this method is the strong requirement of time synchronization. Besides a challenging point would be time coordination, which seems impossible regarding the number of femtocells that can be deployed in a given area. The only way to allocate the resource of a same channel on a time basis without central coordination would be the use of the famous CSMA/CA technique used in Wifi [1] networks which would lead to really poor performance when number of user increase.

Another option would be the usage of clusters. All the femtocells that select the same channel form a cluster. From this cluster we need to extract a cluster's head which will have to coordinate the transmission of each of the femtocell. In this way we avoid the problem of complex coordination but we go back to the famous problem of self organization that we meet in ad hoc network, which bring us among other things to the issue of which head to choose given requirement of high computation capability. We need also to solve some security issue, avoiding a malicious user's being the coordinator and keeping all the resource. However in this option we could make use of QoS principle to grant priority to delay sensitive traffic between several femtocells as in WiMax resource Granting rules.

### 5.3.2 Femtocell Transmission Power

In the previous sections we defined what will the radio resources available to each femtocell be. Now, we present what has to be the transmission power of FAPs, and Femtocell User Equipments (FUEs). Power is one of the key parameters of the problem since a good and accurate tuning of the transmission power will avoid interference outside the femtocell and thus allow an efficient reuse of the bandwidth. The configuration of the transmission power requires taking into account several parameters: Modulation and coding scheme (the higher the modulation scheme the higher the power required maintaining a given BER), the subchannel bandwidth (at a given data rate increasing bandwidth allow decreasing transmission power what we can easily conclude from Shannon's capacity formula [60]), and the channel model. The transmission power has to be set to a value that is on average equal to the power received from the "strongest" co-channel Macrocell plus the required power to cover the entire femtocell area [26]. This process has to be performed periodically to ensure power control, since the network is dynamic and new Macro users or femtocells can appear or disappear. For the

purpose of the simulation, we propose in a first step to fix the transmission power both downlink and uplink. The transmission power will be set to the "classical" value allowed by the 3GPP specifications.

### 5.3.3 Adjacent Channel Interference

We must mention that we didn't find yet a way to account for the Adjacent Channel Interference (ACI). We briefly develop here this issue that is considered here as a valuable future work.

Orthogonality is one of the most valuable features of OFDM, so important that it even gives the name to this transmission technique. However when using OFDMA and thus sharing the same OFDM symbol between multiple senders, orthogonality can not longer be guaranteed by construction. Fully synchronized coherent transmission between users is currently hard to imagine and until proof of feasibility the assumption of uncorrelated senders must hold. Thus the ACI of the Adjacent Channel Leakage power Ratio (ACLR) from the femtocell BS, the mobile station tx and the Adjacent Channel Selectivity (ACS) of the femtocell BS, mobile station receivers need to be taken into account. In order to measure ACLR it is necessary to consider a measurement filter for the transmitted signal as well as a receiver measurement bandwidth for the adjacent channel ("victim") system. ACLR can be mitigated by mean of the guard band already used in the OFDM symbol. In some cases the number/size of the guard band should be enlarged to increase protection from the interfering side-band transmission power of adjacent channels. Therefore there will be a tradeoff between increased protection through guard bands and increased capacity which requires less unused subcarriers. It is worth mentioning that the problem is even worse for femtocells where this phenomenon occurs both in Uplink (UL) and Downlink (DL) in contrast to macrocells where it is likely to happen only in UL.

Similar scenarios occur when two different systems coexist in the same frequency band, such as 802.16 and CDMA-DS of IMT-2000. In some cases isolation of about 10 dB can be required to avoid severe degradations even for second adjacent channels. Given the transmitted powers, path losses in the selected scenarios and the ACLR and ACS performances of the base stations, SubStations ( in WiMAX) and mobile stations in each system, the effective interference may be calculated.

**Part III**  
**Results**

## Chapter 6

# Analytical Results of the Stochastic Model of EDCA

In this chapter, we present the results of our analytical model. The parameters used in the model are summarized in Table 6.1. If not specified, we assume in the following scenarios that default parameters (cf. Table 6.1) are used. We derived the throughput for an IEEE 802.11b infrastructure cell with the basic EDCA scheme. The study of IEEE 802.11a is straightforward since it is just required to change the data rate and some parameters specific to this standard. Besides, RTS/CTS can be modeled simply by taking into account  $T_{c_r}$  instead of  $T_{c_b}$  in the collision time where  $T_{c_r}$  stands for the collision of the RTS/CTS packet only. Before presenting the results we briefly outline in which way we compute our model

### 6.1 Equations System

In this section we describe how we solve our model and retrieve analytical results. As we saw in section 4.1.5, all the steady state probability rely only on  $b_{0,0,0,0}$ . To compute the  $b_{0,0,0,0}$  we need also  $P_i$  etc... Thus to derive throughput and delay we need:

$$\begin{aligned}
p_i &= f_{p_i}(\tau_0, \dots, \tau_3) \\
\tau_i &= f_{\tau_i}(p_i, b_i) \\
b_i &= f_{b_i}(p_i, p_b) \\
p_b &= f_{p_b}(v_0, \dots, v_3) \\
v_i &= f_{v_i}(b_i, p_i)
\end{aligned}$$

Where we denote by  $f_X$  the function which compute the parameter  $X$ . It's useful to present this set of equation in this manner as we can see quickly how all the parameter are linked together since we show here the inputs of each function. Notice that  $p_b$  is independent of  $i$ .

If we try to substitute  $p_i$  it will bring us to an infinite loop, as you can see below.

$$\begin{aligned}
p_i &= f_{p_i}(f_{\tau_0}(p_0, b_0); \dots; f_{\tau_3}(p_3, b_3)) \\
p_i &= f_{p_i}(f_{\tau_0}[p_0, f_{b_0}(p_0, f_{p_b}(f_{v_0}(b_0, p_0), \dots, f_{v_3}(b_3, p_3)))]]; \dots; f_{\tau_3}[p_3, f_{b_3}(p_3, f_{p_b}(f_{v_0}(b_0, p_0), \dots, f_{v_3}(b_3, p_3)))]])
\end{aligned}$$

Therefore it's better to stop the loop when the variable are only  $p_i$  and  $b_i$ .

It leads to a 8 non linear equations system as follows:

$$\begin{aligned}
p_i &= f_{p_i}(f_{\tau_0}(p_0, b_0); \dots; f_{\tau_3}(p_3, b_3)) \\
b_i &= f_{b_i}(p_i, f_{p_b}(f_{v_0}(b_0, p_0), \dots, f_{v_3}(b_3, p_3)))
\end{aligned}$$

We have to remind that  $i$  is the index of the  $AC_i$  and is between 0 and 3. Thus each of the two equations mentioned have 4 versions.

Let's now write the function mentioned above.

$$\begin{aligned}
f_{p_0}(a, b, c, d) &= 1 - [(1-a)^{M-1}(1-b)^M(1-c)^M(1-d)^M] \\
f_{p_1}(a, b, c, d) &= 1 - [(1-a)^{M-1}(1-b)^{M-1}(1-c)^M(1-d)^M] \\
f_{p_2}(a, b, c, d) &= 1 - [(1-a)^{M-1}(1-b)^{M-1}(1-c)^{M-1}(1-d)^M] \\
f_{p_3}(a, b, c, d) &= 1 - [(1-a)^{M-1}(1-b)^{M-1}(1-c)^{M-1}(1-d)^{M-1}]
\end{aligned}$$

$$f_{\tau_i}(a_i, b_i) = \left[ \frac{1 - (p_e + (1 - p_e)a_i)^{m+h+1}}{(1 - p_e)(1 - a_i)} \right] b_i$$

$$\begin{aligned}
f_{b_i}(a_i, b) &= \left[ \frac{1-q}{q} + [Ts](1 - (p_e + (1 - p_e)a_i)^{m+h+1}) \right. \\
&\quad + (1-q) \left( \frac{1 - (1-b)^{A+1}}{b} \right) + q \frac{(1+N.b)1 - (1-b)^{A+1}}{b(1-b)^{A+1}} \\
&\quad + ([Tc]a_i + 1) \left( \frac{1 - p_{fi}^{m+h+1}}{1 - p_{fi}} \right) + ([Te](1 - p_i)p_e) \left( \frac{1 - (p_e + (1 - p_e)a_i)^{m+h+1}}{(1 - p_e)(1 - a_i)} \right) \\
&\quad + \frac{1 + N.b}{2(1-b)^A} ([1 - (1-q)(1-b)^{A+1}]W_0 \\
&\quad + \sum_{j=1}^{m+h} W_j(p_e + (1 - p_e)a_i)^j) + (p_e + (1 - p_e)a_i)^{m+h}]^{-1}
\end{aligned}$$

$$f_{p_b}(a, b, c, d) = 1 - (1-a)^M(1-b)^M(1-c)^M(1-d)^M$$

$$f_{v_i}(b_i, a_i) = b_i(1 - (p_e + (1 - p_e)a_i)^{m+h+1}) \left[ T_s + \frac{a_i T_c + (1 - a_i)p_e T_e + 2}{(1 - p_e)(1 - a_i)} \right]$$

All those function were calculated in Matlab. In the following section we detail the results obtained.

It is worth mentioning that we first tried to solve this set of non linear equations using the fixed point theorem. This method is a well known numerical method to solve non linear equations. However at the end of our mathematical analysis we needed to pose a validity condition for convergence which was  $P_e \rightarrow 1$  which was not realistic. Thus we abandoned this method. Regardless, we decided to include in the appendix the development of this

Parameter	value
aSlotTime	20 $\mu s$
Propagation delay	1 $\mu s$
SIFS	10 $\mu s$
Data rate	11 Mbps
Packet size	1500 bytes (default)
PHY header	192 bits
MAC header	272 bits
ACK	PHY header +14 bytes
AIFSN[AC:0..3]	7,3,2,2
CWmin[AC:0..3]	15,15,7,3 (default)
CWmax[AC:0..3]	1023,1023,15,7 (default)
number of stations	5 (default)
BER	0 (default)
q	1 : saturated (default)

Table 6.1: EDCA Default Parameter Values

analysis for two main reasons: first it took a significant period of the thesis to develop it, and also because it may be helpful for someone who wishes to reuse the method for similar problems.

## 6.2 Unsaturated mode and error prone channel effects on the throughput

Fig.6.1 shows the throughput for basic EDCA schemes in ideal channel under different traffic loads. There are five active stations with four access categories per STA. We observe that there are 3 main phases. The first one lasts until  $q = 9.10^{-5}$ . In this phase, since the offered traffic is not really high, there is no need to differentiate the high priority ACs, thus the available bandwidth is shared equally. During the second phase in which  $9.10^{-5} \leq q \leq 6.10^{-3}$ , we see the gradual starvation of each  $AC_i$  as the its load increases. The third phase is the saturation phase: the offered traffic is greater than the available bandwidth, and priority is given to  $AC_3$ .

Fig. 6.2 plots variations of the throughput both in ideal and error-prone channels for different packet sizes. The scenario is unchanged.

We chose a common value for the BER in a wireless environment. Fig. 6.2 clearly demonstrates the tradeoff between a small packet size for error

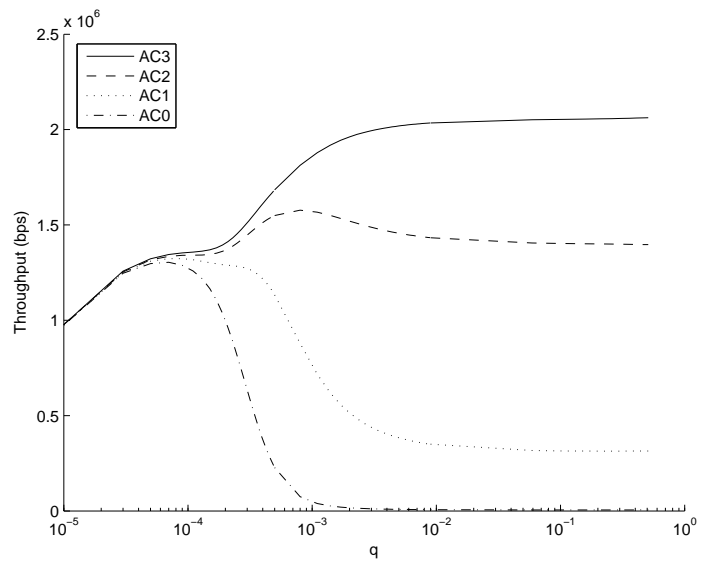

Figure 6.1: Throughput under different traffic loads



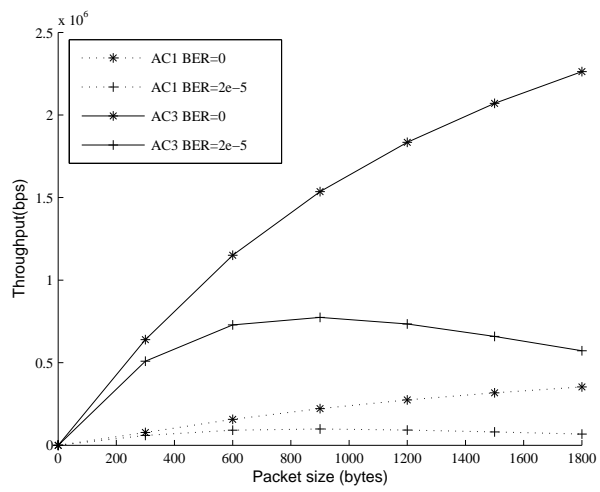

Figure 6.2: Throughput under different error-prone environments vs. packet size

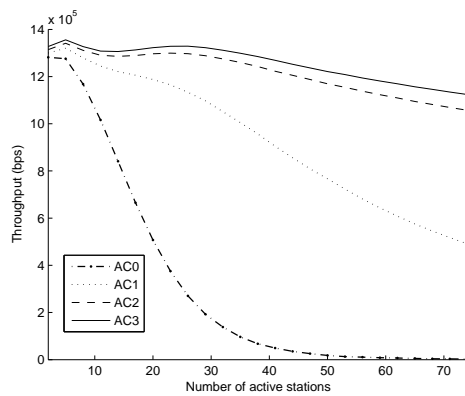

Figure 6.3: Throughput vs. Number of active stations in unsaturated mode

prone channels and a large packet size that reduces the overhead. In addition, we observe that assuming an ideal environment is a coarse assumption since, for instance, the throughput for  $AC_3$  for an impaired channel (with a packet size of 1500 bytes) is less than half of the ideal model prediction that can be found in the literature.

Fig. 6.3 shows the influence of the number of STAs on the throughput in unsaturated mode whereas the traffic load for each STA remains constant. Even though the curves are quite close to the ones obtained with different traffic loads (Fig. 6.1), we observe that this time  $AC_2$  does not encounter a starvation when the number of stations increases – this can be explained because  $AC_2$  and  $AC_3$  have the same  $AIFSN = 2$  in our scenario. The non-differentiation between  $AC_2$  and  $AC_3$  is observed for any number of stations in the IEEE 802.11b cell – we plot this result for up to 75 stations in order to obtain a theoretical result, even though such a high number of stations is obviously unusual for an IEEE 802.11b cell. We will see further that AIFS differentiation is more significant than CWmin differentiation.

### 6.3 AIFS and CWmin differentiation mechanism

We will now study how the key features of the QoS differentiation mechanism of the IEEE 802.11e interact with different traffic load scenarios, and the number of stations.

#### 6.3.1 AIFS mechanism

Fig.6.4 shows the variation of the throughput against the number of stations with different AIFS for each  $AC_i$  (default AIFS and "new" AIFS:  $AIFS[AC_0]=5$ ,  $AIFS[AC_1]=4$ ,  $AIFS[AC_2]=3$ ,  $AIFS[AC_3]=2$ ). Ideal channel and saturated mode is assumed. We observe that the differentiation is sharper with the default parameters.

#### 6.3.2 CWmin mechanism

In Fig. 6.7 we run the same scenario we used in order to study the effect of AIFS but against the traffic load and for different values of CWmin (default CWmin and "new" CWmin:  $CWmin[AC_i=0..3]=15$ ). We compare the default value of the parameters where CWmin differentiation is used but without AIFS differentiation i.e  $AIFSN[AC_i]=3$  for  $i=0..3$  against no CWmin differentiation. As we can see CWmin does not perform effective differentiation as AIFS did.

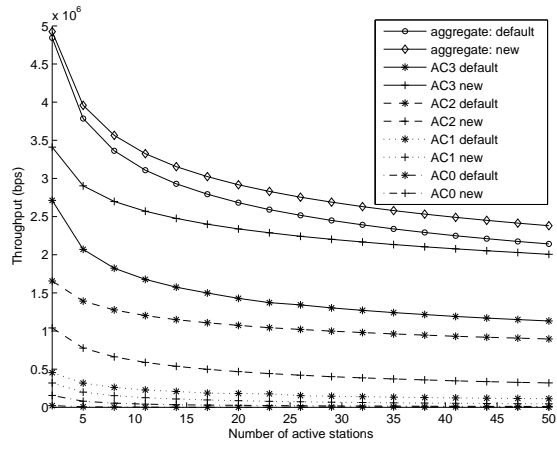

Figure 6.4: Impact of AIFS differentiation on the throughput in saturated mode

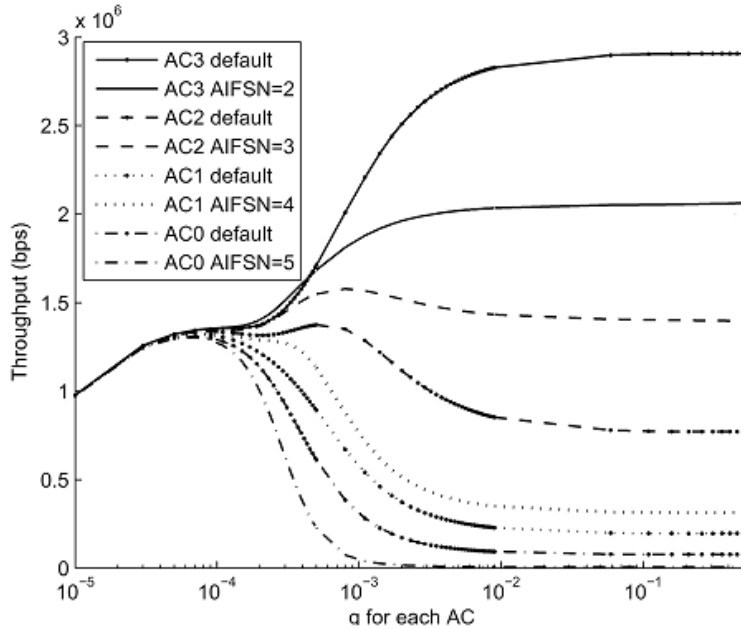

Figure 6.5: AIFS differentiation under different traffic loads

It is interesting that the performance of QoS queues in EDCA behave as the ones in Wimax (IEEE 802.16) [5]. WiMax also propose 4 queues: Unsolicited Grant Service (UGS), Real-Time Polling Service(rtPS), Non-Real-Time Polling Service (nrtPS) and Best Effort(BE). In [25] (Figs 5a-b, and 6a-d) we notice a similarity with our figures 6.1 and 6.5.

## 6.4 Some delay results

In this section we show some of the results that we derived thanks to a recursive delay derivation model introduced in [48]. We do not show the same amount of graphs as for the throughput because this recursive method suffers from a high complexity leading to a huge computing time. The reason we did not encounter the same problem with throughput computation is that for the throughput we do not have to compute the steady-state probabilities over the whole Markov Chain. It is enough to compute  $b_{0,0,0,0}$  probability and then all other transition probabilities and then throughput expression are derived directly. However for the delay derivation we have to go over the whole Markov Chain and compute the steady state probabilities for each state of the Chain. This leads obviously to very big computations even for

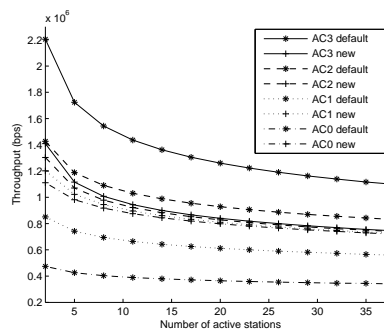

Figure 6.6: Impact of CWmin differentiation on the throughput in saturated mode

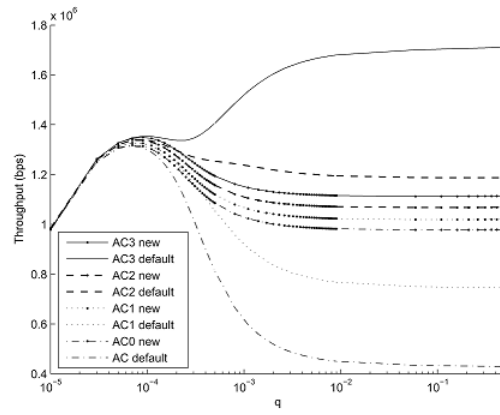

Figure 6.7: CWmin differentiation under different traffic loads

small numbers of stations. In the framework of our future work we have already begun ,we are developing heuristic methods usually used for solving multidimensional markov chains. We expect that the processing time will then decrease significantly. In Fig. 6.8 we observe the effect of the number of stations connected to the AP on the delay experienced by each STA. We notice the efficiency of the differentiation mechanism which gives priority to  $AC_1$ . When we are close to the saturation point, the delay increases even for  $AC_1$  due to the high number of collisions. Unlike the previous case, in Fig. 6.9 if we consider only 5 STAs, the differentiation mechanism is efficient even when the traffic load increases. This is because when the number of stations is fixed, increasing the traffic load does not lead to an increase of the collision probability.



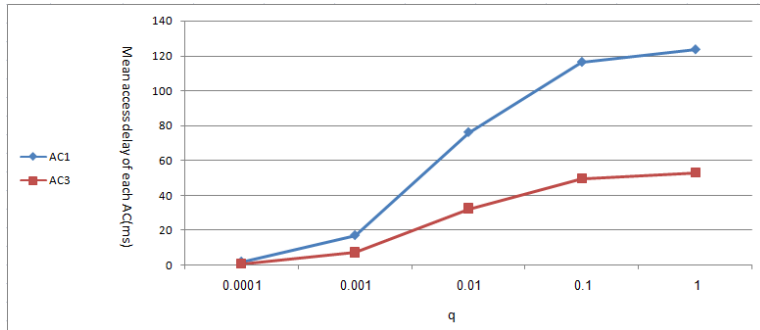

Figure 6.8: Delay differentiation under different traffic loads

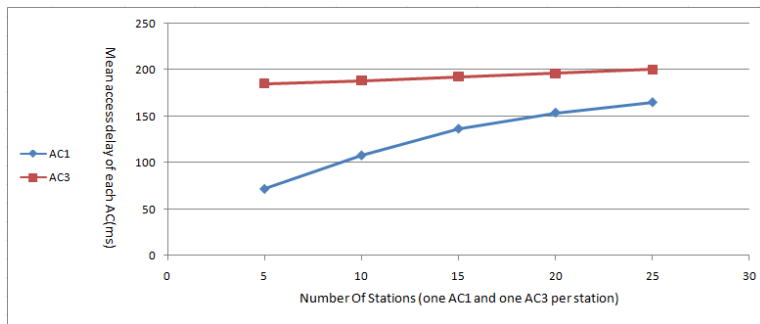

Figure 6.9: Delay experienced with different number of stations

## Chapter 7

# Simulation and Results for Femtocell Channels Reuse

In this chapter we present the performances achieved by the schemes proposed in Chap. 5. In the next section we present the indicators we choose to assess the performance of femtocells. Then we show the simulator we developed for the purpose of our research. Finally the results obtained from different scenarios are presented.

### 7.1 Performance derivation

In this section we present the different indicators we used to derive the performance of the femtocells. First of all, we use the Received Signal Strength (RSS). It stands for the signal power received in a given device. If for example we consider the femtocell downlink case, then the RSS will be the signal power received by the Femtocell User Equipment (FUE) from its serving Femtocell Access Point (FAP). To compute the RSS we need to subtract from the transmitted power (e.g. here at the FAP), the propagation loss of the signal. Propagation loss depend on the propagation models used which we discuss further in 7.2.1. We have to note here that RSS does not take into account the interference of the different users transmitting at the same time on the same channel. Even if Shannon's Capacity [59] formula is not linked to RSS, this indicator is still interesting. The reason is that even if we consider a device "ideally" alone with its serving Access Point (AP) thus without interference from outside, if the RSS is very low, the receiving device will not be able to decode correctly the signal. Thus in every device, a parameter called "receiver sensitivity" defines what is the mini-

mum level of RSS required to be able to provide a minimum service. In the context of femtocells and macrocells, this indicator is especially important since propagation loss are somewhat different in each layer. When FUE is connected through the Macrocell Access Point (MAP) the penetration loss due to walls, windows etc... can lead to outages due to lower RSS than receiver sensitivity. This problem is often more critical in downlink than in uplink, because User Equipment (UE) are often limited in the quality of the electronics inside due to price constraints and battery consumption whereas this can be leveraged when dealing with AP.

The second indicator we used in the following is the Signal to Interference and Noise Ratio (SINR) also called Carrier to Interference and Noise Ratio (CINR). It is important to distinguish this indicator from the Signal to Noise Ratio (SNR). In the latter we only take into account the thermal noise inherent to every electronic component and that depends on the temperature and the bandwidth of the channel we transmit over. Unlike SNR, in SINR we also take into account the interferences due to simultaneous transmissions over the same channel from other UEs or APs. As indicated by its name the SINR accounts for the ratio of the RSS to the thermal noise level and the outside interferences. Unlike RSS, the derivation of SINR is different whether it is for the downlink or the uplink.

In downlink the interference is from the APs whereas in the uplink the interference is from other UEs. Thus for example when we compute the downlink SINR at the FUE we first compute the RSS from its serving FAP, and then we divide this value by RSSs from other MAPs and FAPs that are transmitting on the same channel and the thermal noise at the FUE.

In addition to the computation of SINRs we made the following assumptions. For the downlink we investigated 3 tiers of interfering MAPs whereas for the uplink case we consider interferences only from the MUEs located in the same cell as the FAPs or MAP where we compute the SINR. Moreover we do not consider FAPs and FUEs in adjacent cells since the penetration loss attenuates their already low transmitted powers under a negligible level.

## 7.2 Simulation Parameters

As a worst case scenario for femtocells capacity, we investigate several network configurations in a very dense urban environment. Furthermore, in comparison with real networks, we assume relatively high macro transmit powers without modeling power control and DTX for interference reduction.

### 7.2.1 Propagation Models

In the following sections we present the propagations models used to compute the several different performance indicators such as SINR etc... Depending on the position of the AP and User Equipment (UE) considered we require different models. We assume along all our work here, that MAP and Macrocell User Equipment (MUE) are outdoor, and that FAP and FUE are indoor.

#### MAP to MUE model and vice-versa

For the macrocell path loss calculation over a distance  $d$  in meters we use the model reported in [41], where path loss is modelled as  $28 + 35 * \text{Log}_{10}(d)$  dB where  $d$  is the distance from the base station. Shadow fading is modelled as random process with log-normal distribution 8 dB standard deviation for the macrocell signal where other houses and obstacles are implicitly modelled.

#### MAP to FUE or FAP to MUE model and vice-versa

For the outdoor to indoor propagation and vice-versa we mixed two propagation models. First, we reuse the outdoor propagation model presented above to account for the loss from the outdoor equipment (MAP or MUE) until we meet the external wall of the house. Then for the penetration inside the house and the last meter until the indoor equipment (FAP or FUE) we account for 0.8 dB of loss for each meter of propagation according to Table II of [8]. Finally we account for the penetration loss due to external and internal wall. We derive a random number of external walls in  $[0,1.5]$  and internal walls in  $[0,4]$ . For each external and internal wall we assume 15 and 10 dB of loss respectively.

#### FAP to FUE model and vice-versa

For the indoor propagation model we refer again to [8] and [3] where path loss is considered as  $37 + 20 * \text{Log}_{10}(d) + q_{int} * 5$ , where  $q_{int}$  the number of internal walls is a random number in  $[0,3]$

#### FAP to FAP model and vice-versa

In this model we account for indoor to indoor propagation but also in some cases (e.g. where two FAPs are not located in the same building) indoor-to-outdoor-to-indoor propagation model. We reuse the model still proposed in

[8] which consist in choosing  $\max(15.3 + 37.6 * \text{Log}_{10}(d); 37 + 20 * \text{Log}_{10}(d))$  to which we add loss for external and internal walls.

### 7.3 Macrocell-Femtocell Simulator

To be able to analyze our proposition we developed a system-level simulator. Existing simulator are either too expensive or even confidential (proprietary to some research institutes), or at least without open code. Femtocell is a relatively recent technology and thus, do not appear in the basic features of existing simple simulators, thus without open code we could not add this feature. Therefore we decide to develop our own simulator. It was written in C# language. In the following we present the interfaces to the simulator and the Graphical User Interface (GUI).

In fig 7.1 we can see the first window that appear when running our simulator. We can choose at the beginning how many sectors can be in one cell. The most frequent is three but one or six are also possible. We need to remind that this has nothing to do with our Partial reuse scheme where each sector no matter how many there are, is itself split into 6 sectors. Then we need to enter the number of MUE and FAP per sector, assuming one FUE per FAP , without loss of generality. There is no limit to the number of users in each level but obviously running time grow with high numbers.

In the second part we have to enter the physical parameters such as the transmission power in Uplink and Downlink for both femtocell and macrocell. In a second window we can also define the number of subchannels to be available in each sector both for MUEs and FUEs. In our study we did not consider the gain of antenna and the losses in cables etc... for purpose of simplicity. Thus the transmission power we refer to, over all this study can be considered as the Equivalent Isotropically Radiated Power (EIRP) which already includes all the gains and losses. Finally we did not consider here a specific bandwidth for each channel allocated either to MUE or FUE. Thus to account for thermal noise we choose a common value of  $-100$  dBm by default.

When we run the simulator we get the following figure (see Fig. 7.2 ).

We can see the MAP of interest (denoted further  $MAP_{oi}$ ) in violet colour circled by 19 MAP as usual in simulation scenarios. This big number of MAPs is intended to avoid edge effects. In each of the sectors of  $MAP_{oi}$ , appears small red circles which represent the MUE. Yellow circles and blue squares stand for FAP and FUE respectively. FAPs do not appears in the sectors of MAP adjacent to  $MAP_{oi}$  because we consider that the effect of

**User Inputs - Press on the button when you ready to start.**

How many sectors in each MAP?

How many MUE per sector?

How many FAP in sector?

Downlink

MAP: Signal Power (dBm)

FAP: Signal Power (dBm)

Uplink

MUE: Signal Power (dBm)

FUE: Signal Power (dBm)

MUE spread: 1. Normal. 2. Edges. 3. Center.

Femto spread: 1. Normal. 2. Edges. 3. Center.

BS Noise

Femto Noise

Mix Radius

Max distance from FAP to FUE

Figure 7.1: first interface to the simulator: entering initial parameters

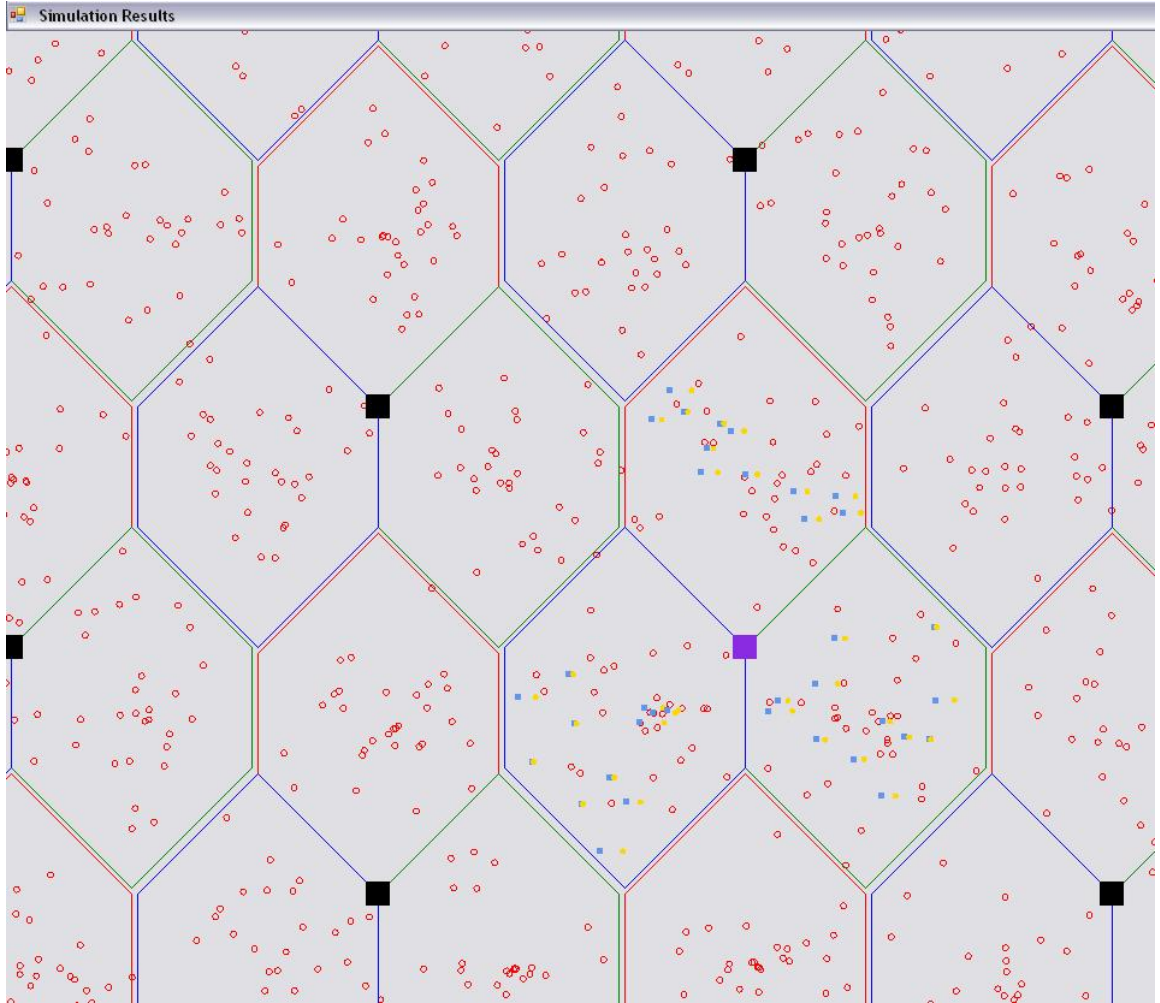

Figure 7.2: Distribution of MUE, and FAP

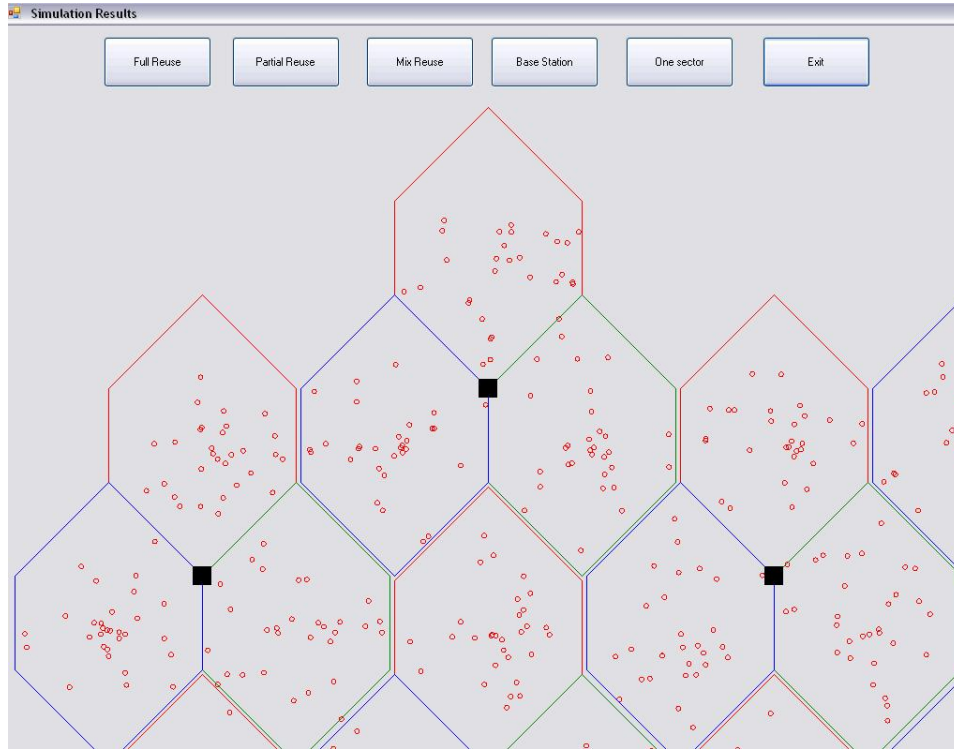

Figure 7.3: Selection of the scheme

FAP of one sector on FAP of other sectors is negligible given the low transmission power as mentioned above. This consideration is only for purpose of simplicity in our simulator.

As we may notice this figure shows the full reuse scheme. However as mentioned previously we can also simulate other schemes such as Mixed reuse etc... as we can see in Fig. 7.3, just by clicking on the desired scheme.

In Fig. 7.5 we show the Partial reuse scheme, and in Fig.7.4 the Mixed reuse scheme, as displayed in our simulator. When we choose one of the schemes, let's say Full reuse, we get the following windows which display some results.

In Fig. 7.7 and Fig. 7.6 we show how results are displayed respectively for downlink and uplink. In the two first column we give the coordinates of the FAP. Then the sector where it is located, and the distance from the overlaying MAP or  $MAP_{oi}$ . Then level of Noise and SNR are given. Finally the subchannel number selected by the FAP is also displayed.

Besides we propose also to provide the minimum, maximum and average



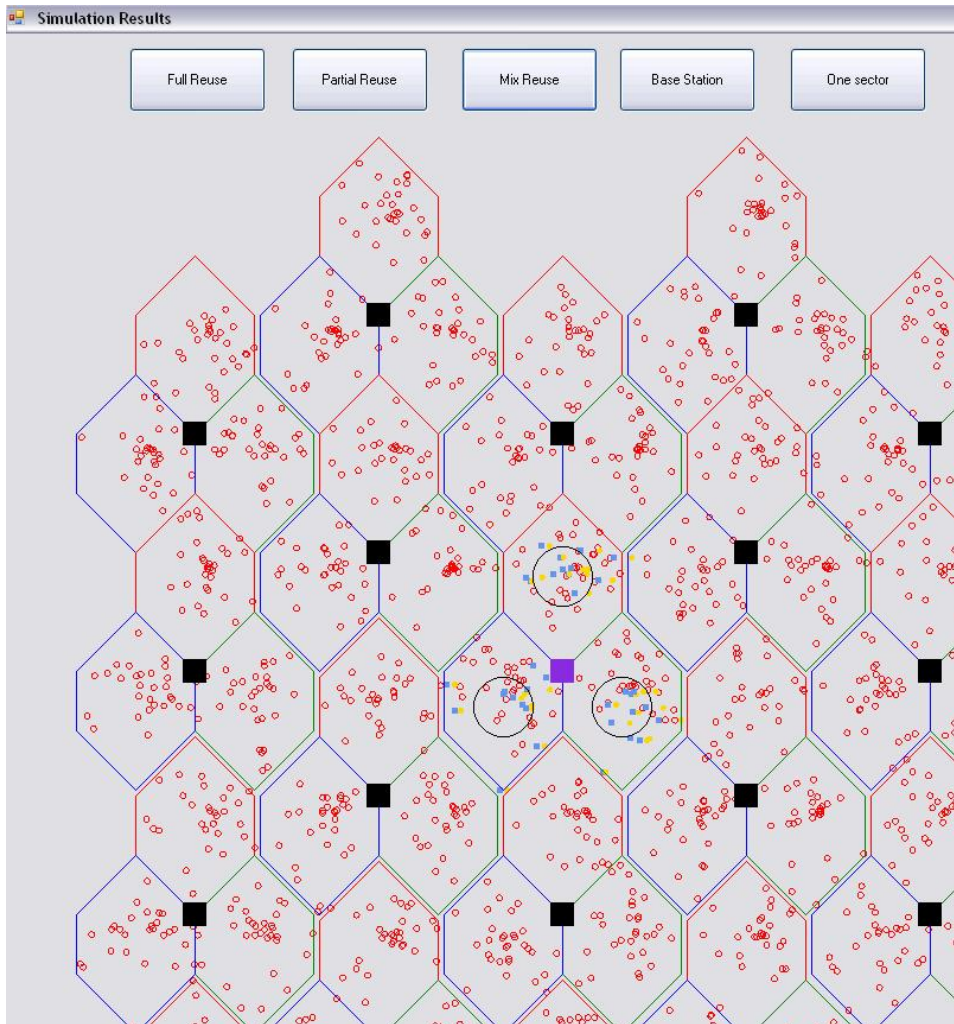

Figure 7.4: Mixed Scheme display

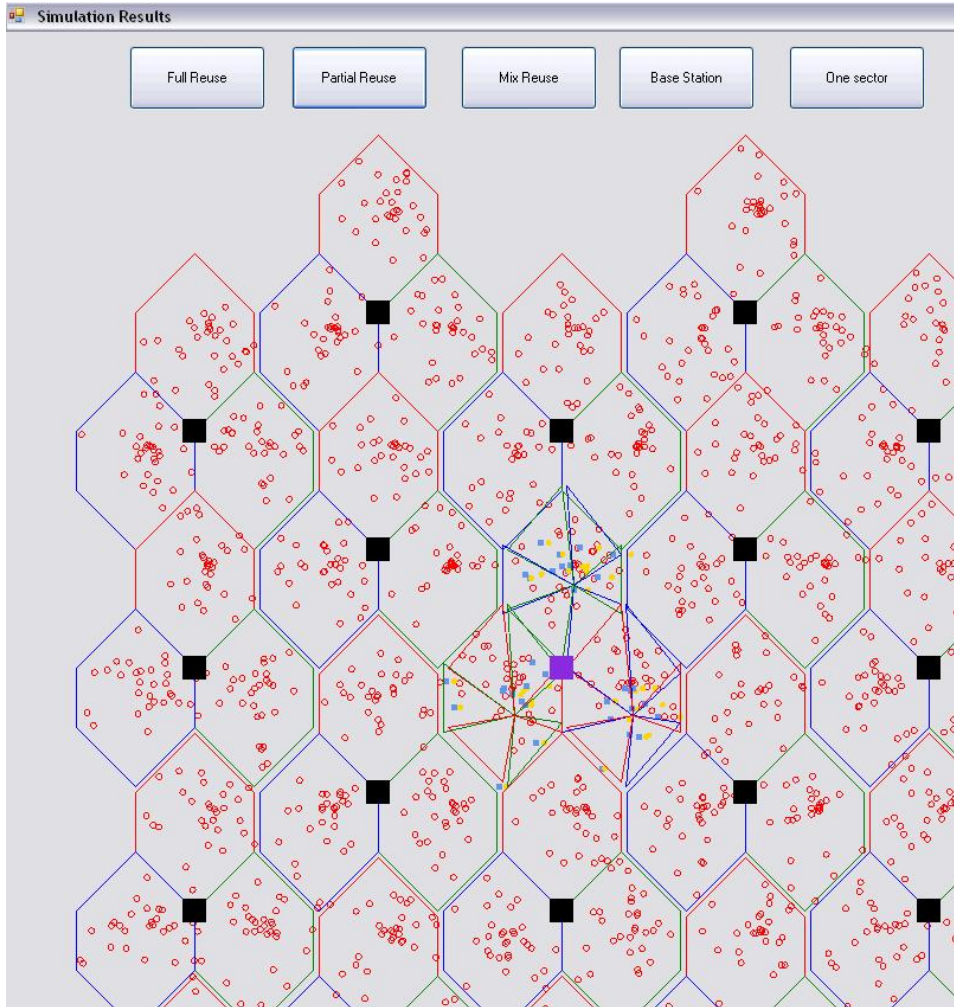

Figure 7.5: Patial scheme display

Full Reuse: Results for the Femtocells - Uplink.

Femto_X	Femto_Y	Sector	Distance	Noise	SNR	Freq
885.9857	780.8032	1	2	2804.2093143	-51.925379224	69
880.7101	815.2135	1	4	2715.2497614	-51.785372779	45
719.8338	718.4696	1	1	2772.6619260	-51.876244136	55
729.93	784.2535	1	10	2776.6061650	-51.882417788	43
822.0128	765.2773	1	5	2741.2168815	-51.826708926	35
826.623962	763.83264	1	15	2825.6544950	-51.958465526	75
853.6998	769.1615	1	11	2844.4462495	-51.987252226	76
898.7534	703.54724	1	6	2898.5723194	-52.069116353	73
842.020752	827.73193	1	12	2763.3242409	-51.861593411	1
740.922	703.7882	1	16	2762.9155206	-51.860951003	90
841.637451	777.81384	1	4	2819.6808198	-51.943274451	62
745.85473E	782.2345	1	14	2825.6449320	-51.958450822	85
908.2617	1002.4276	2	4	2800.7027231	-51.919945088	89
906.30163E	933.07244	2	6	2749.0892282	-51.839163311	68
930.592957	973.2897	2	19	2817.2031048	-51.945456533	88
925	965	2	5	2804.4069167	-51.925685243	69
872.02764E	1031.4751	2	17	2662.1443822	-51.699591003	4
923.28173E	1026.9762	2	2	2740.8672037	-51.826154889	29
924.215942	972.9615	2	1	2747.3567706	-51.836425553	11

Figure 7.6: Display of Uplink results

Full Reuse: Results for the Femtocells - Downlink.

Femto_X	Femto_Y	Sector	Distance	Noise	SNR	Freq
885.9857	780.8032	1	4	2807.2196143	-51.260570943	66
880.7101	815.2135	1	7	2718.2600613	-51.120717093	48
719.8338	718.4696	1	6	2775.6722259	-51.211488851	82
729.93	784.2535	1	3	2779.6164649	-51.217655808	41
822.0128	765.2773	1	6	2744.2271815	-51.162007663	69
826.623962	763.83264	2	16	2828.6647950	-51.293621908	45
853.6998	769.1615	2	16	2847.4565495	-51.322378108	55
898.7534	703.54724	2	15	2901.5826194	-51.404156463	43
842.020752	827.73193	2	10	2766.3345409	-51.196854043	35
740.922	703.7882	2	13	2765.9258206	-51.196212333	75
841.637451	777.81384	2	10	2822.6911198	-51.284440622	76
745.85473E	782.2345	2	3	2828.6952319	-51.293607222	73
908.2617	1002.4276	2	13	2803.7130231	-51.255142643	1
906.30163E	933.07244	2	2	2752.0995282	-51.174448413	90
930.592957	973.2897	2	4	2820.2134047	-51.280626777	62
925	965	2	1	2807.4172167	-51.260876643	85
872.02764E	1031.4751	2	10	2665.1546822	-51.035031253	89
923.28173E	1026.9762	3	5	2743.8775037	-51.161454243	68
924.215942	972.9615	3	15	2750.3670705	-51.171713643	88

Figure 7.7: Display of Downlink results

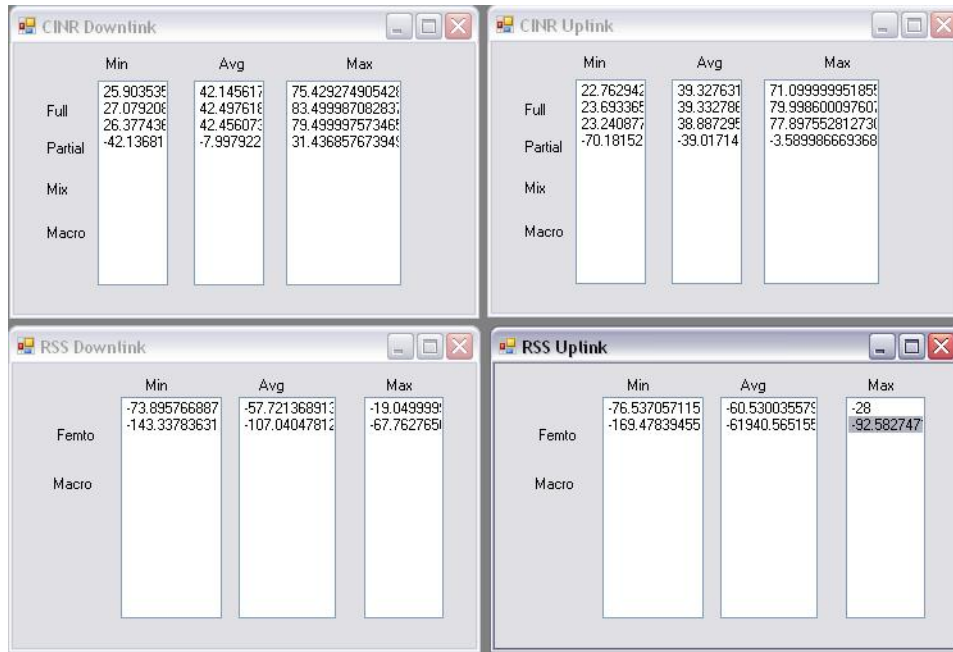

Figure 7.8: Numerical Results for RSS and SINR

of RSS and SINR both in the downlink and the uplink in Fig. 7.8.

## 7.4 Results

### 7.4.1 Introduction

Our goal is to derive how the femtocell can be advantageous over macrocell.

From the FUE point of view, it would enjoy better indoor coverage and higher indoor SINR which would lead to less dropped calls and higher data rates for data oriented applications.

To evaluate the advantage mentioned for FUE which are served by their FAP, we propose to present the following graphs.

First we need to evaluate the SINR achievable in each FUE (downlink) and FAP (uplink). The results depend obviously on the scenario chosen e.g. number of FAPs, number of MUEs, partial reuse or mixed etc... For each scenario we describe the of the SINR which is an efficient way to describe a set of distributed results without listing all of them. We also compute the average, minimum and maximum of SINR. Thus we provide a means of simple and quick comparison between the different schemes proposed.

<b>Parameter</b>	<b>value</b>
MAP sector radius	350 m
FAP radius	20 m
Mixed reuse radius	150 m
Scheme: Full, Partial, Mixed	Full
MUE per sector	50
FAP per sector	150
MUEs deployment:uniform/edge/center	Uniform
FAPs deployment:uniform/edge/center	Uniform
MAP transmission power (EIRP)	50 dBm
FAP transmission power (EIRP)	21 dBm
MUE transmission power (EIRP)	20 dBm
FUE transmission power (EIRP)	18 dBm
noise	-100 dBm

Table 7.1: Macrocell and Femtocell Scenario Default Parameter Values

We refer to Table 7.1 for default values of all of the following scenario. Thus when if not mentioned otherwise, the parameters value are as listed in this table.

#### 7.4.2 Femtocell RSS Performance

In this section we derive the performance of the femtocell via the RSS indicator. Given the different propagation models mentioned we can expect that a FUE served by its own FAP will likely achieve better performance than when linked to the overlaying MAP. However, we may remember that MAP transmission is 30 dB stronger than FAP.

Thus when an FUE is located near the MAP service from the MAP may be better than service from the FAP. Thus we consider here three scenario of FAP deployment: a uniform deployment where all FAPs are uniformly distributed over the sector, an edge deployment where all FAPs are located at the edge of the overlaying macrocell sector, and a centered deployment where the FAPs are located near the MAP. In each figure we show the RSS received when the FUE is connected through its FAP denoted by "femto" and when it is connected through the MAP, denoted by "macro". We notice here that even when the FAP are near the MAP in Fig. 7.13, the RSS received from the FAP is about 60 dB higher when the FUE is connected through the MAP.

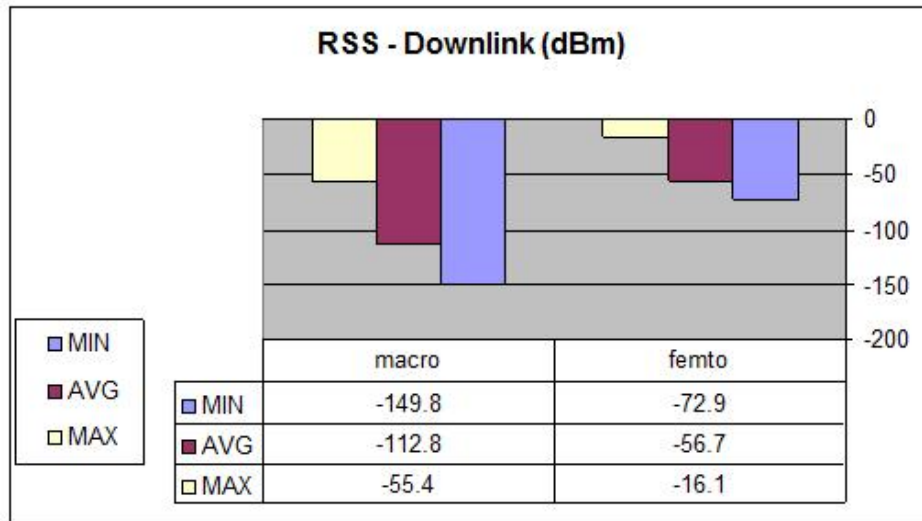

Figure 7.9: RSS in Downlink with uniform distribution

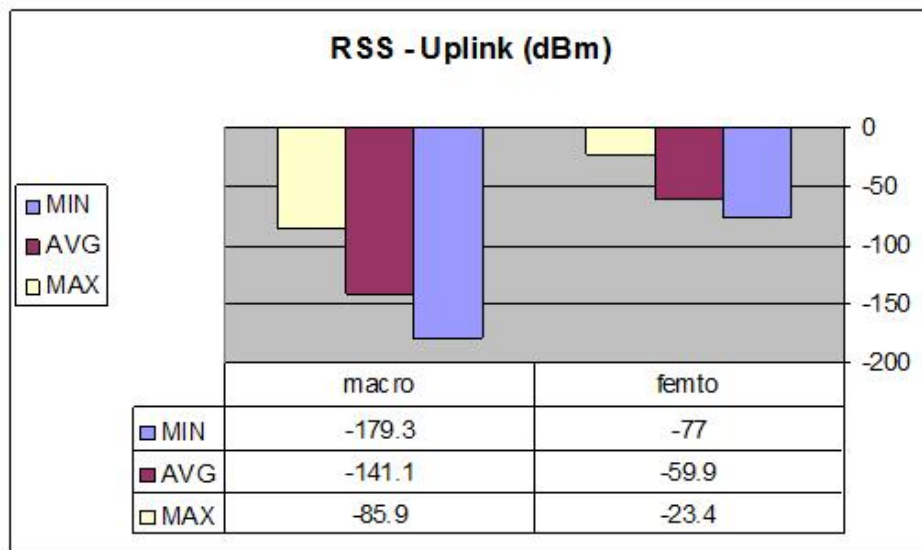

Figure 7.10: RSS in Uplink with uniform distribution

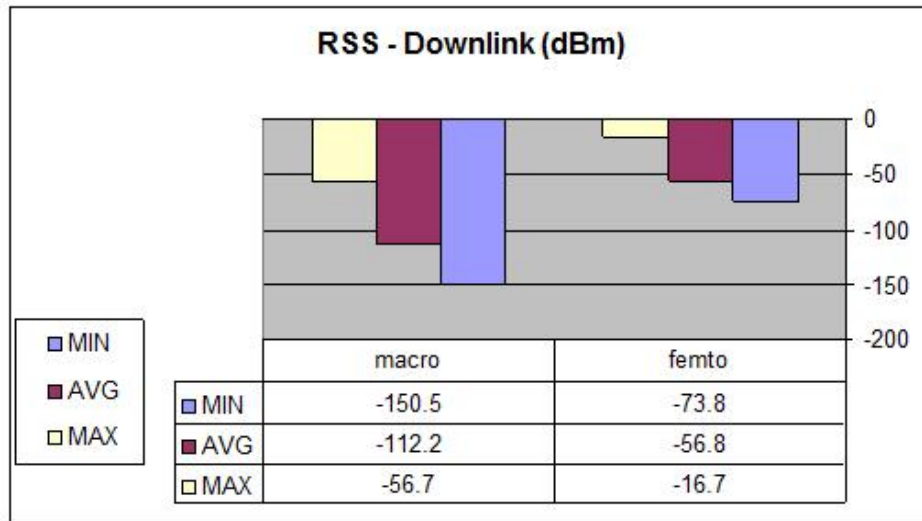

Figure 7.11: RSS in Downlink with concentration at the edge

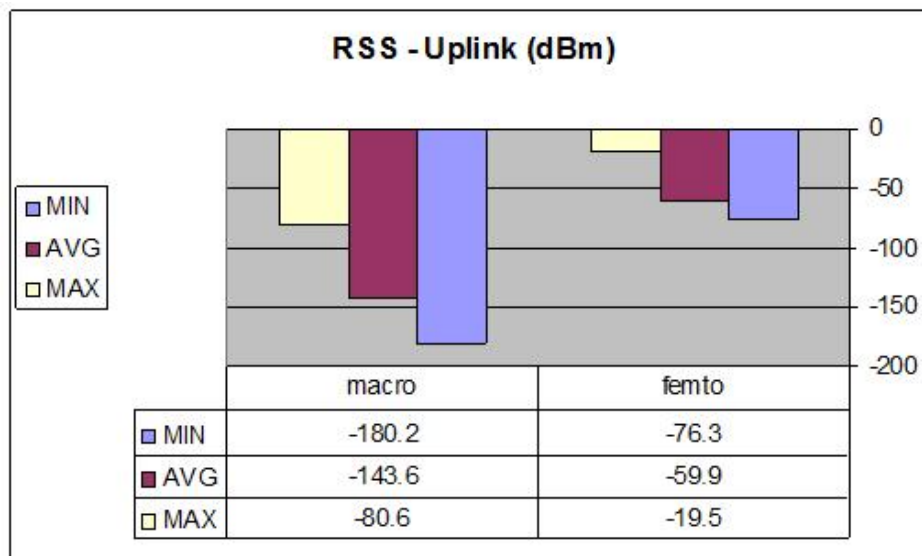

Figure 7.12: RSS in Uplink with concentration at the edge

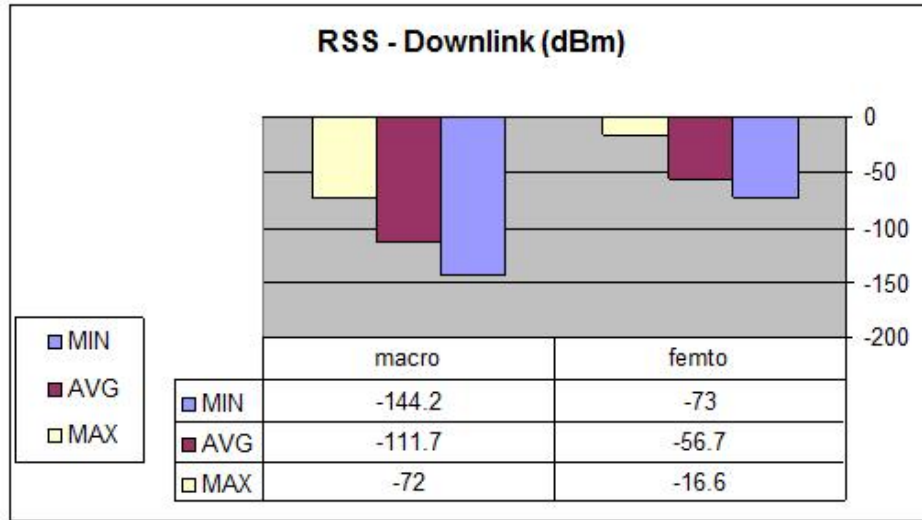

Figure 7.13: RSS in Downlink with concentration in the center

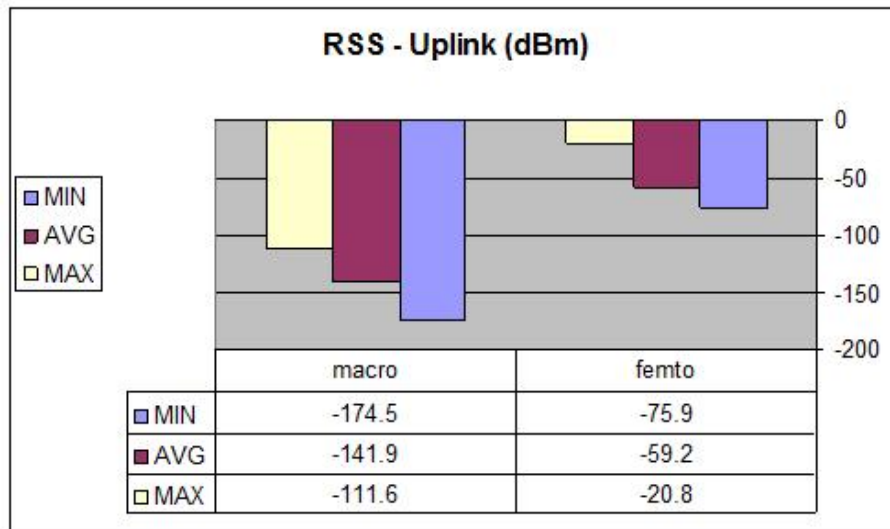

Figure 7.14: RSS in Uplink with concentration in the center



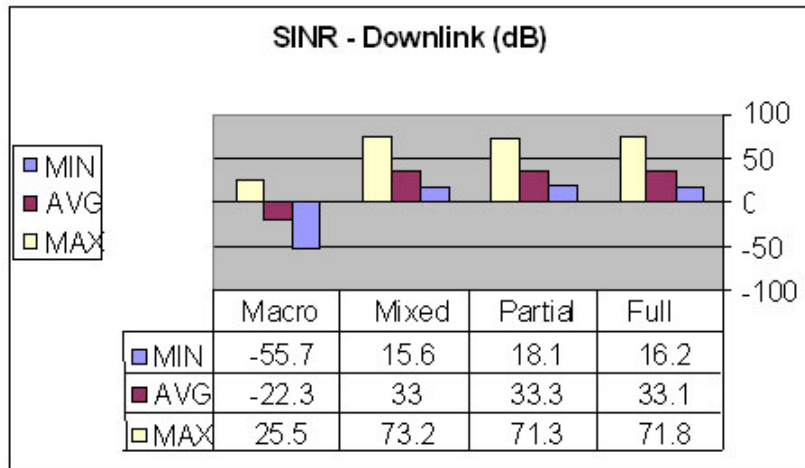

Figure 7.15: Downlink SINR with uniform distribution

Therefore we can state that even users that live near to a MAP may experience a meaningful improved coverage.

### 7.4.3 Femtocell SINR Performance

In this section we wish to assess the performance of the double reuse allocation scheme proposed in Chap. 5. We could not do this before, because our proposed allocation scheme is a means of interference mitigation between users camping on the same channel simultaneously. RSS indicator does not reflect the interferences. In Fig.7.15 we show the average, minimum and maximum values of the SINR for the downlink and in Fig. 7.16 for the Uplink in the case of a uniform deployment. We also provide the Cumulative Distribution Function (CDF) of the SINR for the downlink and Uplink, in Fig.7.17 and 7.18 respectively. In each of these graphs the results denoted by "macro" represents the case without FAP, where FUEs are directly connected to the MAP as for previous graphs. We notice that on average there is no difference between Full, Partial or Mixed reuse. However there is a meaningful difference between the macrocell and femtocell performance. In both downlink and Uplink femtocell a gain of more than 50 dB and 80 dB respectively can be achieved.

In Fig. 7.19 and 7.20 we consider an edge deployment. We observe an unexpected result. The full reuse scheme outperformed the remaining schemes. This can be explained by the fact that in Partial and Mixed reuse

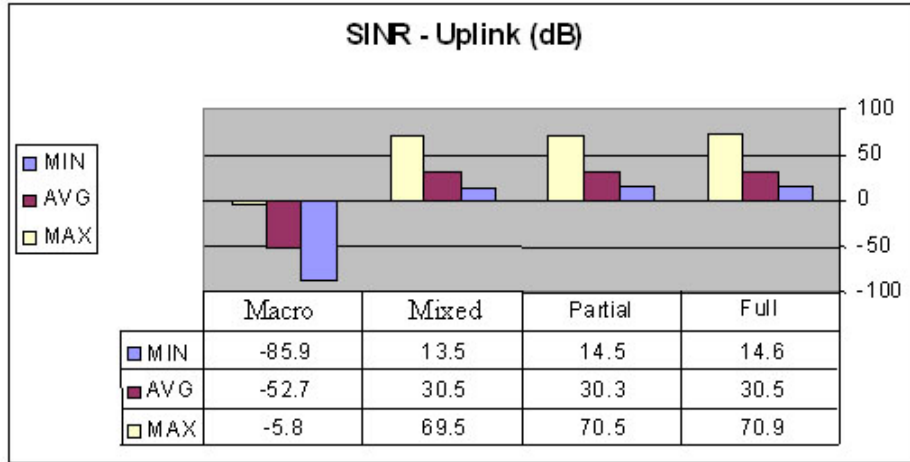

Figure 7.16: Uplink SINR with uniform distribution

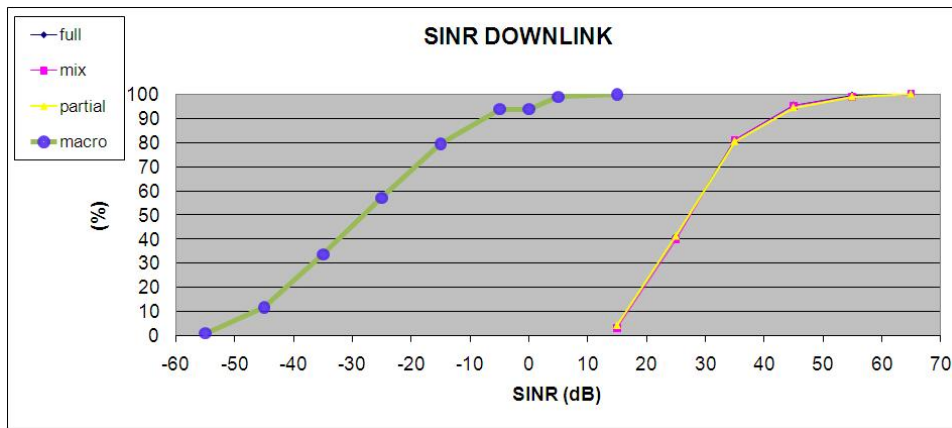

Figure 7.17: Downlink SINR CDF with uniform distribution

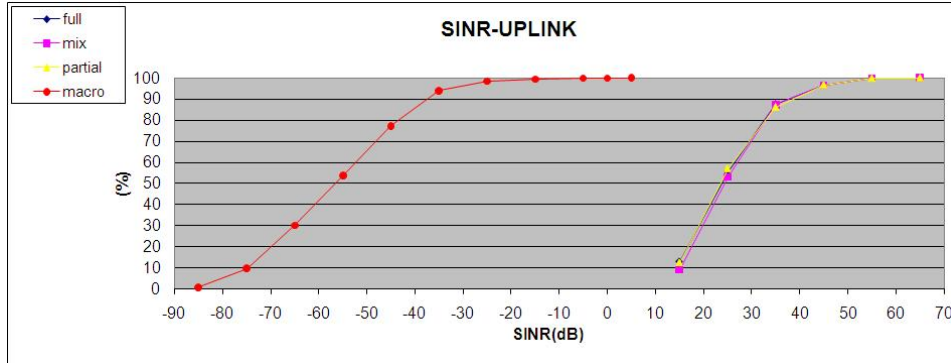

Figure 7.18: Uplink SINR CDF with uniform distribution

schemes, the number of channels available to the neighboring FAPs is limited whereas for the full reuse method more channels are available for femtocells, thus more flexibility to mitigate inter-femtocell interferences. However as previously noticed in Chap. 5, the drawback of the full reuse scheme is the potentially large amount of channels to be sensed.

#### 7.4.4 Effect of the Transmission Power

In this section we try to assess the effect in changing the different transmission power of each of the component of the network: FUEs, MUEs, FAPs, MAPs. In each of the scenarios we evaluate the impacts on femtocell performances. Along all the scenarios presented we still keep the values presented in Table 7.1 if not mentioned differently.

##### Effect of the MAP Transmission Power

In Figs. 7.21 and 7.22 we investigate the effect of the MAP transmission power on the femtocell Downlink RSS and SINR performance respectively. The graph labeled as "femto" represent the case when the FUE is connected to its FAP. The remaining graphs correspond to the cases when FUE is connected to the MAP. We simulate different MAP transmission power from 35 to 75 dBm. We observe that even if MAP transmits at a relatively high power it is still better for the FUE to be connected to its FAP even if the FAP transmits at only 21 dBm. This can be easily understood given the severe loss due to penetration of macrocell signal into house.

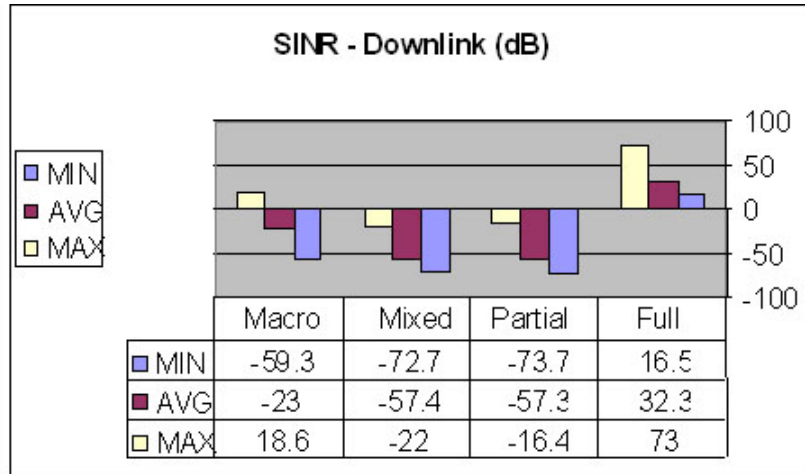

Figure 7.19: Downlink SINR with edge deployment

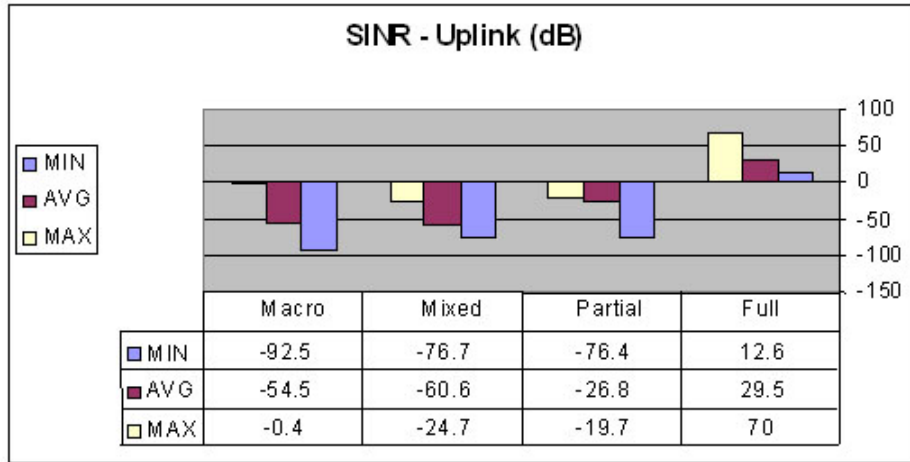

Figure 7.20: Uplink SINR with edge deployment

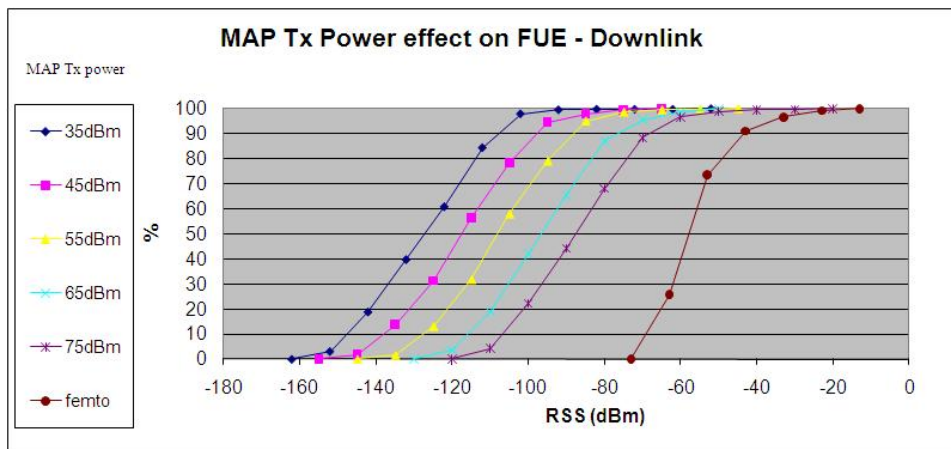

Figure 7.21: Effect of the MAP Tx power on the RSS femtocell Downlink transmission

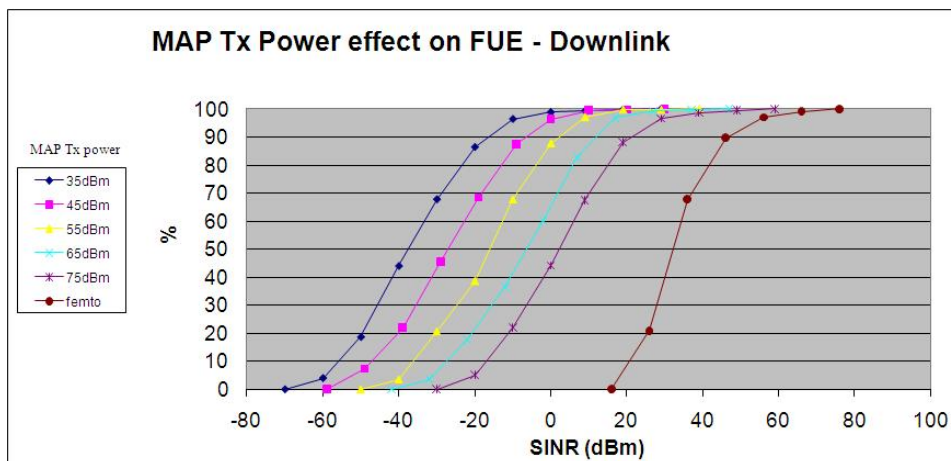

Figure 7.22: Effect of the MAP Tx power on the SINR femtocell Downlink transmission

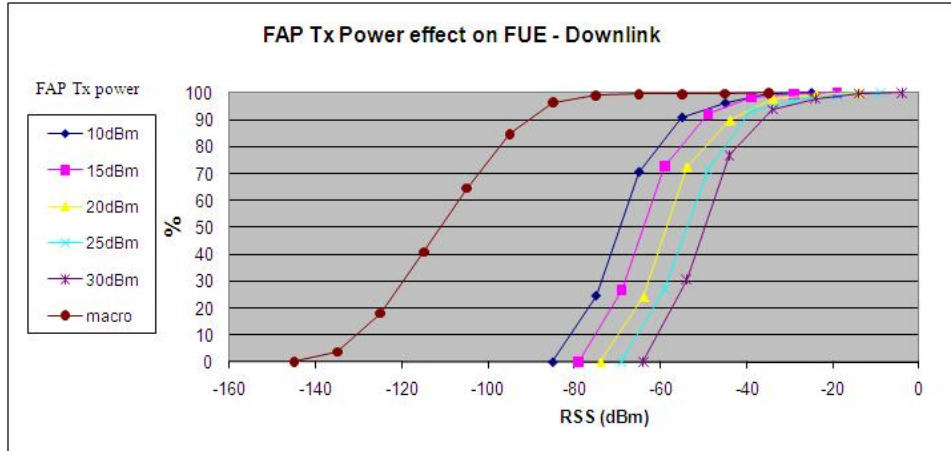

Figure 7.23: Effect of the FAP Tx power on the RSS femtocell Downlink transmission

### Effect of the FAP Transmission Power

In Figs. 7.23 and 7.24 we present the complementary experience to the previous paragraph. We try here to see what will happen if FAP decrease its transmission power. The graph labeled as "macro" correspond to the case where FUE is connected through MAP whereas remaining graphs display performance of the FUE connected to its FAP. We observe that even if FAP transmit to a level as low as 10 dBm it stills outperformed the results that can be achieved by the MAP transmitting at 50 dBm.

### Effect of the MUE transmission Power

In Fig. 7.26 we show two sets of curves. The curves labeled "femto" stand for the FUE connected to its FAP whereas the ones labeled as "macro" correspond to the FUE connected to the MAP. In each of the configuration we vary the MUE transmission power from 10 to 20 dBm. We observe that MUE interference do not have any impact on femtocell Uplink transmission when the FUE is connected to its FAP. However when FUE is connected to the MAP, the impact of other MUE interference is more significant. This can be explained by the fact that when FUE is connected to its FAP it can use a different spectrum than the one used by the overlaying macrocell according to our double reuse allocation scheme. Whereas when connected to the MAP it suffers from Co-channel interference of MUEs.

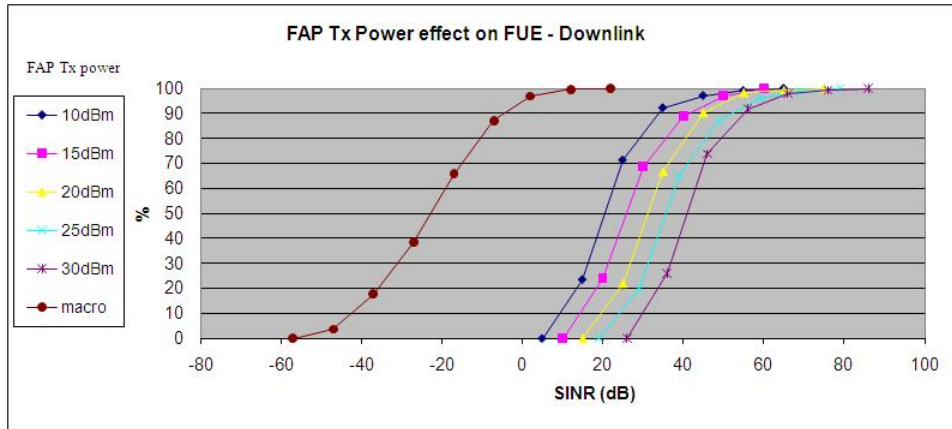

Figure 7.24: Effect of the FAP Tx power on the SINR femtocell Downlink transmission

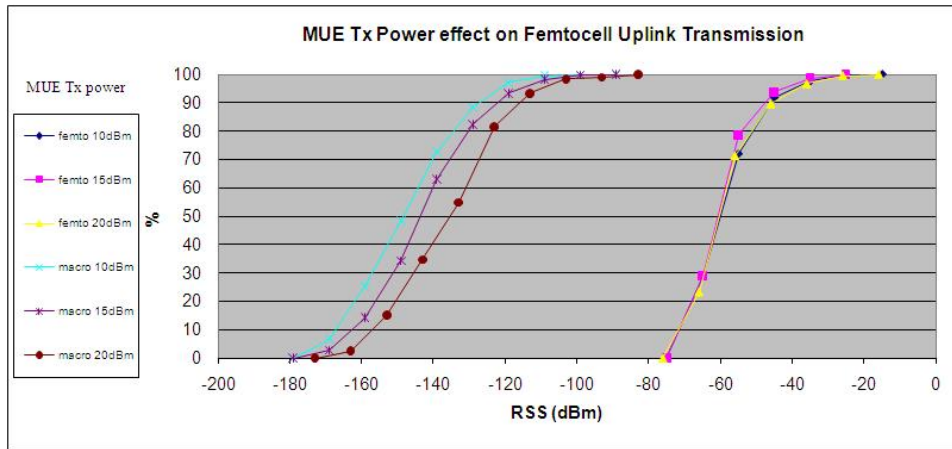

Figure 7.25: Effect of the MUE Tx power on the RSS femtocell Uplink transmission

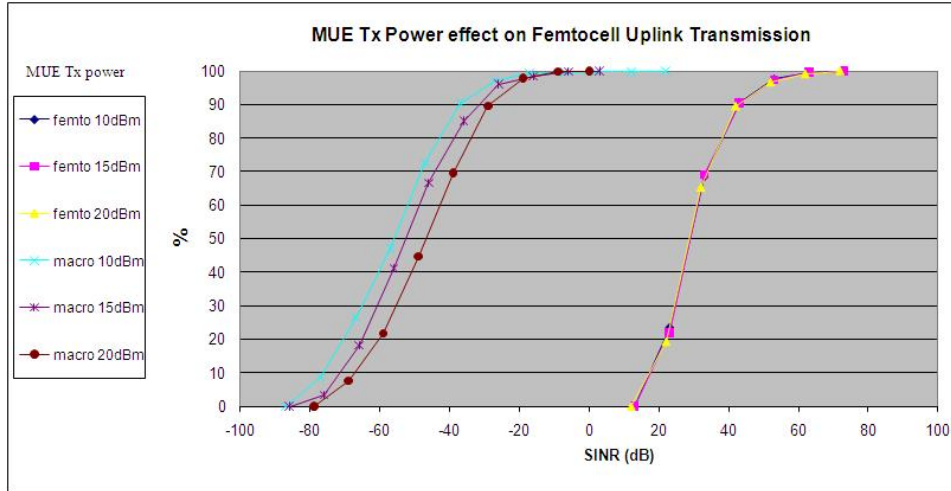

Figure 7.26: Effect of the MUE Tx power on the SINR femtocell Uplink transmission

### Effect of the FUE transmission Power

We evaluate here the effect of the FUE transmission power on the RSS and SINR uplink performance of the femtocell. As for the previous figures of MUE transmission power femto and macro labels refer to the connection of FUE to FAP and MAP respectively. About the RSS performance in Fig. 7.27, we notice obviously that the higher the FUE transmission, the better the RSS achieved, and that the connection to FAP outperforms the connection to MAP. In Fig. 7.28 we present the SINR performance on the femtocell uplink. We can make comments similar to the previous section, which is that when FUE is connected to MAP it suffers from severe interference of MUEs which are camping on the same channel.



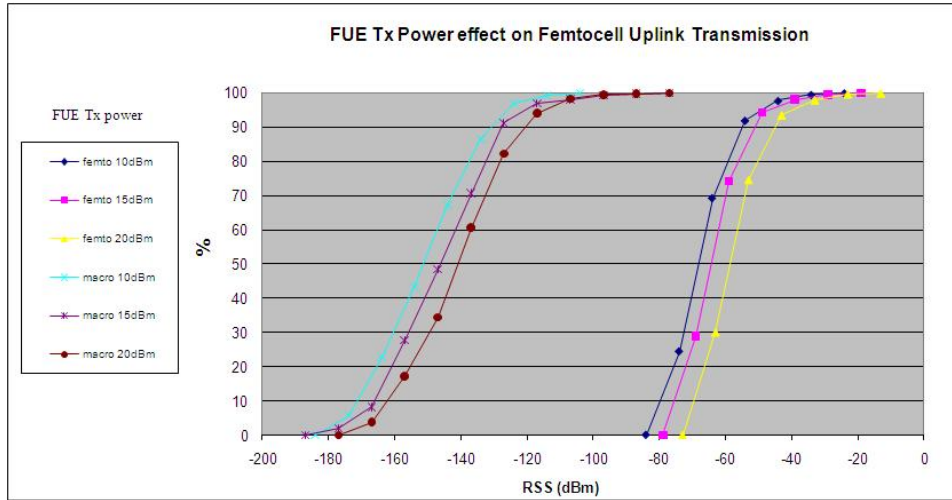

Figure 7.27: Effect of the FUE Tx power on the RSS femtocell Uplink transmission

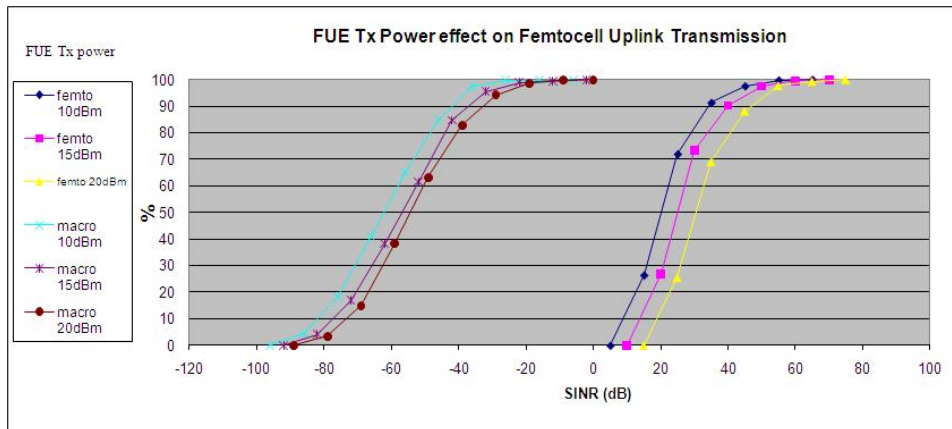

Figure 7.28: Effect of the FUE Tx power on the SINR femtocell Uplink transmission

## Chapter 8

# Conclusion

After the unexpected success of 2G cellular networks to provide mobile users located outside their home with telephone services when moving outdoor, and the increasing deployment of cordless telephones when at home, we are currently experiencing an ever increasing demand for mobile broadband internet access when users are indoor. In this thesis we focused on two technologies: the WiFi technology, and the new femtocell technology. The goal of this thesis was to evaluate each of these two technologies separately for the limiting factor to the capacity that can be offered to an end user. In the WiFi standard, the point that can be considered as the bottleneck of the performance is the multiple access mechanism to the radio resource by several users. In fact even if the CSMA/CA mechanism is a good tradeoff among other access mechanisms such as TDMA, CDMA etc. because it is distributed, to perform its task it still requires a set of waiting times which leads to wasted resources. The challenge was to evaluate the performance of this mechanism, to be able to derive the usual performance indicator such as throughput and delay. Due to the stochastic nature of this mechanism, theoretical models are always naturally used so as to describe the nature of the mechanism. Several models have already been developed but they are all based on simple assumptions. The most common assumptions are that of an ideal channel, saturation throughput, etc. Besides this, existing accurate models do not deal with the enhanced MAC mechanism of the WiFi that provides QoS support.

In the first part of this thesis we developed an accurate EDCA model based on a four dimensional Markov chain. This model is an extension of the model of Kong et al. who extended the original Bianchi model. We modified this model to consider a non-ideal channel where errors occur with

a constant probability. We also consider different traffic scenarios: saturated or unsaturated with different traffic loads. Thanks to our model we studied the effect of the different parameters of the EDCA mechanisms such as differentiation, or AIFS interframe space time, on the achievable throughput. We show that these parameters offer a good differentiation between access categories of different services. We also show the expected delay experienced by a user given his AC. We see that the saturation factor  $q$  has a non negligible effect on the delay which confirms the importance of considering a non saturated model of the network. Thus our model is very rich, which on the one hand makes it more accurate and closer to reality, but on the other hand, requires more complex calculations. The main result of the model lies in the computation of the throughput which reflects the capacity of the system. This result is essential in order to design a deployment tool for WiFi QoS-enabled networks. Our non-saturated model avoid over dimensioning which would lead to interference between different access points.

In the second part of this thesis we assessed the performance of the femtocell. We first presented the challenges and opportunities of this new technology. Then we focused on the main factor limiting performance which is interference . This challenge is directly linked to the way we allocate the radio resources to this "second tier" or second layer network. If we split the common spectrum shared between the macrocell and femtocell layers into two disjoint spectra we enjoy protection from co-channel interlayer interference. However spectrum efficiency is lost. On the other hand if we allow the two layers to share the spectrum we face severe interference . We presented already existing radio resource allocation schemes. We found an interesting fact: lots of methods have already been in existence for a long time and were proposed at the time Femtocell was considered for the 2G GSM technologies. However since the femtocell concept wasn't seriously considered at that time, the proposed allocation schemes were also somewhat "forgotten". We propose a novel allocation reuse scheme which allows mixing the two mentioned approaches, namely spectrum splitting and spectrum sharing. To increase the efficiency of the network resource's use, we proposed to reuse the channels belonging to the neighboring sector of the overlaying macrocell. Three different reuse plans have been proposed, each adapted to a specific scenario. We based our allocation scheme on the existing schemes we presented before but that were proposed in the context of microcells or in other different technologies. Thus we apply these ideas to the concept of femtocell. We assumed that the underlying technology is OFDMA-based which allow splitting the spectrum. Thus our scheme cannot be applied to 3G networks if the operator owns only a single band of frequencies. In the context of this

thesis we developed a static system level simulator which allows us to derive the performance achievable by the femtocell when our allocation scheme is applied. We present the RSS and SINR performance indicators achieved by femtocells for different scenarios. We show that femtocells outperform macrocells in all configurations even when macrocells transmit at relatively high power. In conclusion: can we answer the question "which is the best technology?" Unfortunately we are still not able to name the winner. First of all there may be no winner. Because each technology offers a different quality of service whether it is for data or voice service.

But to be able to consider the best technology even for a given service we have to deal with additional issues. For example we have to consider an end-to-end performance metric. Actually, both femtocell and WiFi are backhauled by the fixed broadband connection of the user. But for the femtocell, as soon as it has reached the gateway of the operator it is allocated dedicated resource in the core network whereas WiFi packet have to travel through regular path with all the congestions that can occur. So maybe WiFi can offer higher data rates, especially if we consider the emerging 802.11 "n" standard. But the required delay may not be suitable for delay sensitive applications such as VoIP based applications. Moreover some advantages can be translated directly into physical performance metrics. For example, one of the main advantages of femtocells is that it allows the use of the same handset already bought, whereas a dual-mode handset is required if we wish our mobile phone to get connected to the WiFi network. Therefore an extended study which includes some financial parameters is required. It will have to compute the CapEx(Capital Expenditure) and OpEx (Operational Expenditure) savings from both the operator's and users' point of view. In addition to the just mentioned open issue we propose as future work the following research orientation. WiFi CSMA/CA access mechanism allows natural interference mitigation. As soon as an undergoing transmission is detected, all other stations are prevented from initiating new transmissions. This is true even for stations that are associated to an adjacent AP (i.e. not the one which is transmitting or receiving at that time). Thus given that there is a limited number of non-overlapping channels used by WiFi devices we have to extend our model to a scenario with multiple cells and not only a single cell. In this manner we could account for additional throughput decreases.

For the femtocell, we considered here a rather simple channel selection based on the least noisy channel. Therefore this can be considered as a greedy algorithm. It would be interesting to assess the performance of the femtocell when a more optimal scheme is used for the sharing of the fre-

quency between femtocells. Game theory may be helpful to this issue.

## Chapter 9

# Appendix :Fixed Point Theorem Method

We use here a famous theorem often useful for numerical problems:

**Theoreme 1** *Let  $X \subset \mathbb{R}^n$ ,  $n \geq 1$  a closed set, and  $\|\cdot\|$  a norm on  $\mathbb{R}$ . Let  $F : X \rightarrow X$  be a function such that there is  $\alpha \in [0, 1[$  such that*

$$\|F(x) - F(y)\| \leq \alpha \|x - y\|$$

*for all  $x, y \in X$ . Thus there is a single point  $P \in X$  such that  $F(P) = P$ . Moreover, let  $x_0 \in X$  and let  $(x_k)_{k \in \mathbb{N}}$  the sequence defined by induction by  $x_{k+1} = F(x_k)$  for  $k \in \mathbb{N}$ . Therefore  $\lim_{k \rightarrow +\infty} x_k = P$  and we have*

$$\|x_k - P\| \leq \alpha^k \|x_0 - P\| \quad (CV)$$

*for all  $k \in \mathbb{N}$ .*

**Remark:** A priori, one does not know  $P$ , But thanks to the inequality (CV), we get a very good approximation because the convergence is very, very fast ( $\alpha < 1!!$ ): the dream for a computer scientist. That's why we try as soon as possible to reduce to a fixed point problem .

**Step 1: nomenclature..** We denote  $\vec{\tau} = (\tau_0, \dots, \tau_3)$  et  $\vec{b} = (b_0, \dots, b_3)$ , where for simplicity  $b_0, \dots, b_3$  denote the vector coordinates of  $b_{0,0,0,0}$ . We denote

$$\begin{aligned} p(\vec{\tau})_i &= (1 - p_e)p_i + p_e \\ &= (1 - p_e)(1 - (1 - \prod_{j=0}^3(1 - \tau_j))\prod_{j=i+1}^3(1 - \tau_j)) + p_e \end{aligned}$$

We have the relationship

$$\tau_i = (1 + p(\vec{\tau})_i + \dots + (p(\vec{\tau})_i)^{m+h})b_i$$

for all  $i$ , and thus,

$$b^i = \frac{\tau_i}{1 + p(\vec{\tau})_i + \dots + (p(\vec{\tau})_i)^{m+h}}.$$

Then we define the function  $f : \mathbb{R}^4 \rightarrow \mathbb{R}^4$  with its coordinates:

$$(f(\vec{\tau}))_i = \frac{\tau_i}{1 + p(\vec{\tau})_i + \dots + (p(\vec{\tau})_i)^{m+h}},$$

and, for  $\vec{b}$  fixed, we try to solve  $f(\vec{\tau}) = \vec{b}$ , i.e.

$$F(\vec{\tau}) = \vec{\tau},$$

with

$$F(\vec{\tau}) = \vec{\tau} - f(\vec{\tau}) + \vec{b}.$$

It was reduced to a fixed point theorem problem: we will try now to apply the theorem. Let fixed first of all a "pleasant" norm:

$$\|x\| = \sup\{|x_i|/i = 0, 1, 2, 3, 4\}.$$

**Step 2: Shrinking.** Let  $\vec{\tau}, \vec{\tau}' \in [0, 1]^4$ . Let  $i \in \{0, 1, 2, 3\}$ . We have

$$\begin{aligned} & |(F(\vec{\tau}) - F(\vec{\tau}'))_i| \\ &= \left| -(\vec{\tau} - \vec{\tau}')_i \left( 1 - \frac{1}{1 + p(\vec{\tau})_i + \dots + (p(\vec{\tau})_i)^{m+h}} \right) \right. \\ & \quad \left. - (\vec{\tau}')_i \left( \frac{1}{1 + p(\vec{\tau})_i + \dots + (p(\vec{\tau})_i)^{m+h}} - \frac{1}{1 + p(\vec{\tau}')_i + \dots + (p(\vec{\tau}')_i)^{m+h}} \right) \right| \\ & \leq \left( 1 - \frac{1}{m+h+1} \right) \|\vec{\tau} - \vec{\tau}'\| + \|\vec{\tau}'\| \frac{\sum_{k=1}^{m+h} (p(\vec{\tau})_i)^k - (p(\vec{\tau}')_i)^k}{\left( \sum_{k=0}^{m+h} (p(\vec{\tau})_i)^k \right) \left( \sum_{k=0}^{m+h} (p(\vec{\tau}')_i)^k \right)} \end{aligned} \quad (9.1)$$

The problem is to evaluate the second term of the right side. We put  $A = p(\vec{\tau})_i$  and  $B = p(\vec{\tau}')_i$ . With a small calculation we get:

$$\begin{aligned} \sum_{k=1}^{m+h} A^k - B^k &= \sum_{k=1}^{m+h} (A - B) \left( \sum_{j=0}^{k-1} A^j B^{k-1-j} \right) \\ &= (A - B) \sum_{j=0}^{m+h-1} \sum_{k=j}^{m+h-1} A^j B^{k-j} \\ &= (A - B) \sum_{j=0}^{m+h-1} A^j \sum_{k=0}^{m+h-1-j} B^k \end{aligned}$$

Because  $A, B > 0$ , we get

$$\left| \sum_{k=1}^{m+h} A^k - B^k \right| \leq |A - B| \cdot \left( \sum_{j=0}^{m+h-1} A^j \right) \cdot \left( \sum_{j=0}^{m+h-1} B^j \right)$$

and thus

$$\frac{\left| \sum_{k=1}^{m+h} A^k - B^k \right|}{\left( \sum_{j=0}^{m+h} A^j \right) \cdot \left( \sum_{j=0}^{m+h} B^j \right)} \leq |A - B| \cdot \left( 1 - \frac{A^{m+h}}{\sum_{j=0}^{m+h} A^j} \right) \cdot \left( 1 - \frac{B^{m+h}}{\sum_{j=0}^{m+h} B^j} \right)$$

Because  $A = p(\vec{\tau})_i \in [p_e, 1]$  and also for  $B$ , by taking formula (9.1), we get

$$|(F(\vec{\tau}) - F(\vec{\tau}'))_i| \leq \left( 1 - \frac{1}{m+h+1} \right) \|\vec{\tau} - \vec{\tau}'\| + |p(\vec{\tau})_i - p(\vec{\tau}')_i| \left( 1 - \frac{p_e^{m+h}}{m+h+1} \right)^2 \quad (9.2)$$

It remains therefore to evaluate  $p(\vec{\tau})_i - p(\vec{\tau}')_i$ . We write it:  $p(\vec{\tau})_i = (1 - p_e) \prod_{j=0}^3 (1 - \tau_j)^{M_j}$ , with  $M_j \in \{M-1, M\}$ . For  $k \in \{0, \dots, 3\}$ , we have

$$\frac{\partial p(\vec{\tau})_i}{\partial \tau_k} = -(1 - p_e) \cdot (1 - \tau_k)^{M_k-1} \prod_{j \neq k} (1 - \tau_j)^{M_j}.$$

We assume henceforth that  $M \geq 2$ . Then we get

$$\left| \frac{\partial p(\vec{\tau})_i}{\partial \tau_k} \right| \leq (1 - p_e) M$$

Thus for  $\vec{\tau}, \vec{\tau}'$ , there is  $t_0 \in ]0, 1[$  such that

$$\begin{aligned} |p(\vec{\tau})_i - p(\vec{\tau}')_i| &= \left| \sum_{k=0}^4 \frac{\partial p_i}{\partial \tau_k} (t\vec{\tau} + (1-t)\vec{\tau}') \cdot (\tau_k - \tau'_k) \right| \\ &\leq 4(1 - p_e) M \|\vec{\tau} - \vec{\tau}'\| \end{aligned} \quad (9.3)$$

If we substitute (9.3) into (9.2), we get

$$|F(\vec{\tau}) - F(\vec{\tau}')| \leq \alpha \|\vec{\tau} - \vec{\tau}'\|$$

with

$$\alpha = 1 - \frac{1}{m+h+1} + 4(1 - p_e) M \left( 1 - \frac{p_e^{m+h}}{m+h+1} \right)^2. \quad (9.4)$$



Thus, if we manage to get  $p_e$  close to 1 (i.e. a big probability of error in a packet !), then we have  $\alpha < 1$ .

**remark:** The problem is that in the formula of  $\alpha$ , if  $M$  is big, we are in a problem... We can maybe refine: Let be  $\delta \in [0, 1]$  and let us consider the domain

$$D_\delta = \{\vec{\tau} \in [0, 1]^4 / \exists j \text{ tel que } 1 - \tau^j \leq \delta\}$$

Then we get that

$$\left| \frac{\partial p(\vec{\tau})_i}{\partial \tau_k} \right| \leq (1 - p_e) M \delta^{M-2}$$

for all  $\vec{\tau} \in D_\delta$ . In this case, if  $\delta < 1$ , we have  $\lim_{M \rightarrow +\infty} M \delta^{M-2} = 0$ , and we get back a small coefficient in the formula of  $\alpha$ .

**Step 3:**  $F$  is defined on  $[0, 1]^4$ , and it has to get its value in  $[0, 1]^4$  too. Let be  $i \in \{0, \dots, 3\}$ . With the same calculation as in step 2, we get

$$|F(\vec{\tau})_i| \leq \left( 1 - \frac{1}{m+h+1} \right) \|\vec{\tau}\| + \|\vec{b}\|$$

Thus if we set that

$$\|\vec{b}\| \leq \frac{1}{m+h+1},$$

we have  $|F(\vec{\tau})_i| \leq 1$ . The concern is that  $F(\vec{\tau})_i$  is not always positive... Thus we set

$$\tilde{F}(\vec{\tau}) = (\max\{0, F(\vec{\tau})_0\}, \dots, \max\{0, F(\vec{\tau})_3\})$$

And now all go well:  $\tilde{F} : [0, 1]^4 \rightarrow [0, 1]^4$  and  $\|\tilde{F}(\vec{\tau}) - \tilde{F}(\vec{\tau}')\| \leq \alpha \|\vec{\tau} - \vec{\tau}'\|$ . Finally the theorem states that there is  $\vec{\tau}$  such that  $\tilde{F}(\vec{\tau}) = \vec{\tau}$ .

Let us show that  $F(\vec{\tau}) = \vec{\tau}$ . Let be  $i$ . We have  $\tilde{F}(\vec{\tau})_i = \tau_i$ .

Case 1: if  $\tau_i > 0$ , then  $\tilde{F}(\vec{\tau})_i > 0$ , and therefore  $\tilde{F}(\vec{\tau})_i = F(\vec{\tau})_i$ .

Case 2: if  $\tau_i = 0$ , we have  $\tilde{F}(\vec{\tau})_i = 0$ , and thus  $F(\vec{\tau})_i \leq 0$ . But because  $\tau_i = 0$ , we have  $F(\vec{\tau})_i = b_i \geq 0$ , thus  $\tilde{F}(\vec{\tau})_i = F(\vec{\tau})_i = 0$ .

In brief, in all cases,  $F(\vec{\tau}) = \tilde{F}(\vec{\tau}) = \vec{\tau}$ , and thus  $f(\vec{\tau}) = \vec{b}$ , and we find a solution that converges fast. To summarize we have the following Theorem:

**Theoreme 2** Assume that  $\|\vec{b}\| \leq \frac{1}{m+h+1}$ . Assume that  $\alpha < 1$ , where  $\alpha$  is given by (9.4). Then there is  $\vec{\tau} \in [0, 1]^4$  such that  $f(\vec{\tau}) = \vec{b}$ , and we can get a very good approximation of  $\vec{\tau}$ .

# Bibliography

- [1] IEEE STD 802.11-1999, IEEE Standard for Information technology-Telecommunications and information exchange between systems-Local and metropolitan area networks-Specific requirements - Part 11: Wireless LAN Medium Access Control (MAC) and Physical Layer (PHY) Specifications, 1999.
- [2] Digital cellular telecommunications system (phase 2+); gsm cordless telephony system (cts), phase 1; service description; cts radio interface layer 3 specification. Draft GSM 04.56 version 8.0.0 Release 1999, Mars 200.
- [3] Feasibility study for enhanced uplink for ultra fdd (release 6). 3GPP Technical Report TR 25.896 V6.0.0 (2004-03), 3GPP, Mar. 2004.
- [4] Wireless Medium Access Control (MAC) and Physical Layer (PHY) Specifications: Medium Access Control (MAC) Quality of Service Enhancements, IEEE Std. 802.11e, Sep 2005.
- [5] Ieee standard for local and metropolitan area networks part 16: Air interface for fixed and mobile broadband wireless access systems amendment 2: Physical and medium access control layers for combined fixed and mobile operation in licensed bands and corrigendum 1. *IEEE Std 802.16e-2005 and IEEE Std 802.16-2004/Cor 1-2005 (Amendment and Corrigendum to IEEE Std 802.16-2004)*, pages 1–822, 2006.
- [6] IEEE Std. 802.11-2007, IEEE Standard for Information technology-Telecommunications and information exchange between systems-Local and metropolitan area networks-Specific requirements - Part 11: Wireless LAN Medium Access Control (MAC) and Physical Layer (PHY) Specifications(Revision of IEEE Std 802.11-1999), June 2007.
- [7] Interference management in umts femtocells. Technical report, Femto Forum, Dec. 2008.

- [8] 3GPP. Hnb and hnb-macro propagation models. TSG-RAN WG4 44-bis R4-071617, Qualcomm Europe, Oct 2007.
- [9] Norman Abramson. The aloha system: another alternative for computer communications. In *AFIPS '70 (Fall): Proceedings of the November 17-19, 1970, fall joint computer conference*, pages 281–285, New York, NY, USA, 1970. ACM.
- [10] F. Alizadeh-Shabdiz and S. Subramanian. A finite load analytical model for the iee 802.11 distributed coordination function mac. In *Proceedings of the Workshop on Modeling and Optimization in Mobile, Ad Hoc and Wireless Networks (WiOpt '03)*, page 321–322, Sophia Antipolis, France, March 2003.
- [11] M. Almgren, L. Bergstrom, M. Frodigh, and K. Wallstedt. Channel allocation and power settings in a cellular system with macro and micro cells using the same frequency spectrum. In *Vehicular Technology Conference, 1996. 'Mobile Technology for the Human Race', IEEE 46th*, volume 2, pages 1150–1154, April 1996.
- [12] Jeffrey G. Andrews, Arunabha Ghosh, and Rias Muhamed. *Fundamentals of WiMAX: Understanding Broadband Wireless Networking*. Prentice Hall, Sep. 2007.
- [13] A. Banchs and L. Vullero. A delay model for 802.11e edca. *IEEE Communications Letters*, 9(6):508–510, June 2005.
- [14] L. Berlemann, S. Mangold, G. Hiertz, and B. Walke. Delay performance of the enhanced distributed channel access of iee 802.11e. In *IST Mobile Summit 06*, page 5, Mykonos, Greece, Jun 2006.
- [15] G. Bianchi. IEEE 802.11-Saturation throughput analysis. *IEEE Communications Letters*, 2:318–320, 1998.
- [16] G. Bianchi. Performance Analysis of the IEEE 802.11 Distributed Coordination Function. *IEEE Journal on Selected Areas in Communications*, 18(3):535–547, 2000.
- [17] G. Bianchi, L. Fratta, and M. Oliveri. Performance Evaluation and Enhancement of the CSMA/CA protocol for 802.11 Wireless LAN. In *Proc. PIMRC*, pages 392–396, Oct. 1996.

- [18] F. Cali, M. Conti, and E. Gregori. IEEE 802.11 wireless LAN: Capacity analysis and protocol enhancement. In *IEEE INFOCOM*, volume 1, pages 142–149, Mars 1998.
- [19] Frederico Cali, Marco Conti, and Enrico Gregori. Dynamic tuning of the ieee 802.11 protocol to achieve a theoretical throughput limit. *IEEE/ACM Trans. Netw.*, 8(6):785–799, 2000.
- [20] G. R. Cantieni, N. Qiang, C. Barakat, and T. Turletti. Performance analysis under finite load and improvements for multirate 802.11. *Computer Communications*, 28(10):1095–1109, June 2005.
- [21] Vikram Chandrasekhar and Jeffrey G. Andrews. Uplink capacity and interference avoidance for two-tier cellular networks. In *GLOBECOM*, pages 3322–3326. IEEE, 2007.
- [22] P. Chatzimisios, V. Vitsas, and A. C. Boucovalas. Throughput and delay analysis of the ieee 802.11 protocol. In *proc of IEEE international Workshop on Networked Appliances (IWNA)*, pages 168–174, 2002.
- [23] S.T.S. Chia. Radio and network resource management for third generation mobile systems. In *Vehicular Technology Conference, 1993 IEEE 43rd*, pages 935–937, 18-20 1993.
- [24] I Chih-Lin, L.J. Greenstein, and R.D. Gitlin. A microcell/macrocell cellular architecture for low- and high-mobility wireless users. *Selected Areas in Communications, IEEE Journal on*, 11(6):885–891, Aug 1993.
- [25] Dong-Hoon Cho, Jung-Hoon Song, Min-Su Kim, and Ki-Jun Han. Performance analysis of the ieee 802.16 wireless metropolitan area network. volume 0, pages 130–137, Los Alamitos, CA, USA, 2005. IEEE Computer Society.
- [26] H. Claussen. Performance of macro- and co-channel femtocells in a hierarchical cell structure. In *Personal, Indoor and Mobile Radio Communications, 2007. PIMRC 2007. IEEE 18th International Symposium on*, pages 1–5, 2007.
- [27] Jürgen Deissner, Andre Noll Barreto, Ulrich Barth, and Gerhard Fettweis. Interference analysis of a total frequency hopping gsm cordless telephony system. In *GSM Cordless Telephony System, T Proc. PIM-RC'98*, pages 1525–1529, 1998.

- [28] Jürgen Deissner and Gerhard Fettweis. Increased capacity through hierarchical cellular structures with inter-layer reuse in an enhanced gsm radio network. *Mobile Networks and Applications*, 6(5):471–480, 2001.
- [29] X.J. Dong and P. Varaiya. Saturation throughput analysis of IEEE 802.11 Wireless LANs for a lossy channel. *IEEE Communications Letters*, 9(2):100–102, 2005.
- [30] Paal Engelstad and Olav N. Østerbø. Delay and throughput analysis of iee 802.11e edca with starvation prediction. In *LCN*, pages 647–655. IEEE Computer Society, 2005.
- [31] H. Eriksson, B. Gudmundson, J. Skold, J.K. Ugland, and P. Willars. Multiple access options for cellular based personal communications. In *Vehicular Technology Conference, 1993 IEEE 43rd*, pages 957 –962, 18-20 1993.
- [32] Chuan Heng Foh and Juki Wirawan Tantra. Comments on iee 802.11 saturation throughput analysis with freezing of backoff counters. *IEEE Commun. Lett*, 9:130–132, 2005.
- [33] M. Frullone, G. Riva, P. Grazioso, and C. Carciofi. Analysis of optimum resource management strategies in layered cellular structures. In *Universal Personal Communications, 1994. Record., 1994 Third Annual International Conference on*, pages 371 –375, 27 1994.
- [34] M. Frullone, G. Riva, P. Grazioso, and G. Falciasecca. Advanced planning criteria for cellular systems. *Personal Communications, IEEE*, 3(6):10 –15, dec 1996.
- [35] H. Furukawa and Y. Akaiwa. A microcell overlaid with umbrella cell system. In *Vehicular Technology Conference, 1994 IEEE 44th*, pages 1455 –1459 vol.3, 8-10 1994.
- [36] R.W. Gibson, R.J.G. MacNamee, and S.K. Vadgama. Universal mobile telecommunication system - a concept. *Telecommunications*, 21(11):23, Nov 1987.
- [37] David Gonzalez, Virginia Corvino, Silvia Ruiz, Joan Olmos, Mario Garcia-Lozano, and Roberto Verdone. Downlink resource allocation in lte:centralized vs. distributed approach. In *Proc. of COST2100/NEWCOM++ WPR.8 Workshop on Radio Resource Allocation for LTE*, Wien, Austria, Sep. 2009.

- [38] Association GSM. Mobile world celebrates four billion connections gsm world. Webpage, Feb. 2009.
- [39] I. Guvenc, M. Jeong, F. Watanabe, and H. Inamura. A hybrid frequency assignment for femtocells and coverage area analysis for co-channel operation. *IEEE Commun. Lett.*, 12(12), Dec 2008.
- [40] Armin Heindl and Reinhard German. Performance modeling of IEEE 802.11 wireless lans with stochastic petri nets. *Performance Evaluation*, 44:139–164, 2001.
- [41] L.T.W. Ho and H. Claussen. Effects of user-deployed, co-channel femto-cells on the call drop probability in a residential scenario. In *Personal, Indoor and Mobile Radio Communications, 2007. PIMRC 2007. IEEE 18th International Symposium on*, pages 1 –5, 3-7 2007.
- [42] Jie Hui and Michael Devetsikiotis. A unified model for the performance analysis of IEEE 802.11e edca. *IEEE Transactions on Communications*, 53(9):1498–1510, Spetember 2005.
- [43] International Telecommunication Union (ITU). Mobile overtakes fixed. Webpage, Feb 2003.
- [44] H.-S. Jo, J.-G. Yook, C. Mun, and J. Moon. A self-organized up-link power control for cross-tier interference management in femtocell networks. In *Proc. IEEE Military Communications Conference (MILCOM)*, San Diego, CA, Nov. 2008.
- [45] Y. Kinoshita and M.A. Henriques. High density space division multiple access: Double reuse of frequency channels. In *Proc. of International Conference on Universal Personal Communications*, pages 552 – 557, San Diego, CA, Sept 1994.
- [46] Y. Kinoshita, T. Tsuchiya, and S. Ohnuki. Frequency common use between indoor and cellular radio — research on frequency channel doubly reused cellular system. In *Proc. of the 39th IEEE Vehicular Technology Conference (VTC'89)*, volume 1, pages 329 – 335, San Francisco, CA, May 1989.
- [47] Yasuaki Kinoshita and David K. Asano. Frequency double reuse for indoor and urban digital cellular telephone systems — enhanced conceptual design formulae for single handset systems. In *Proc. of the Multiaccess, Mobility and Teletraffic for Personal Communications Workshop (MMT '97)*, pages 247–257, 1997.

- [48] Z. Kong, D.H.K. Tsang, B. Bensaou, and D. Gao. Performance analysis of IEEE 802.11e contention-based channel access. *IEEE Journal on Selected Areas in Communications*, 22(10):2095–2106, December 2004.
- [49] Y.-L. Kuo, E. H.-K. Lu, C.-H. and Wu, G.-H. Chen, and Y.-H. Tseng. Performance analysis of the enhanced distributed coordination function in the IEEE 802.11e. In *in Proc. IEEE Vehicular Technology Conference - VTC '03 - Fall*, pages 3488–3492. Oct, 2003.
- [50] X. Lagrange. Multitier cell design. *Communications Magazine, IEEE*, 35(8):60–64, aug 1997.
- [51] Long Le and E. Hossain. Multihop cellular networks: Potential gains, research challenges, and a resource allocation framework. *Communications Magazine, IEEE*, 45(9):66–73, sep. 2007.
- [52] Haipeng Lei, Xin Zhang, and Dacheng Yang. A novel frequency reuse scheme for multi-cell OFDMA systems. In *Vehicular Technology Conference, 2007. VTC-2007 Fall. 2007 IEEE 66th*, pages 347–351, sept. 2007.
- [53] D. Lopez-Perez, A. Valcarce, G. De La Roche, Enjie Liu, and Jie Zhang. Access methods to WiMAX femtocells: A downlink system-level case study. pages 1657–1662, nov. 2008.
- [54] David Lopez-Perez, Akos Ladanyi, Alpar Juttner, and Jie Zhang. OFDMA femtocells: A self-organizing approach for frequency assignment. In *PIMRC (Personal, Indoor and Mobile Radio Communications)*, Tokyo, Japan, sep 2009. IEEE.
- [55] S. Mangold, G. HIERTZ, and B. WALKE. IEEE 802.11e wireless LAN - resource sharing with contention based medium access. In *proc. of IEEE Personal Indoor Mobile Radio Conference (PIMRC)*, Beijing P. R. China, Sept 2003.
- [56] Qiang Ni, Lamia Romdhani, Thierry Turletti, and Imad Aad. QoS issues and enhancements for IEEE 802.11 wireless LAN. Rapport de recherche 4612, INRIA, Sophia Antipolis, November 2002.
- [57] J. W. Robinson and T. S. Randhawa. Saturation throughput analysis of IEEE 802.11e Enhanced Distributed Coordination Function. *IEEE Journal on Selected Areas in Communications*, 22(5):917–928, 2004.

- [58] M. Salem, A. Adinoyi, H. Yanikomeroglu, and D. Falconer. Opportunities and challenges in ofdma-based cellular relay networks: A radio resource management perspective. *Vehicular Technology, IEEE Transactions on*, Feb 2010.
- [59] C. Shannon. The zero-error capacity of a noisy channel. *IRE Transactions on Information Theory*, 1956.
- [60] C. E. Shannon. Communication in the Presence of Noise. *Proceedings of the IRE*, 37(1):10–21, 1949.
- [61] M. I. Silventoinen, M. Kuusela, and P. A. Ranta. Analysis of a new channel access method for home base station. In *Proc. of 5th IEEE International Conference on Universal Personal Communications (ICUPC)*, pages 930–935, Cambridge, MA, USA, 1996.
- [62] Marko I. Silventoinen. *GSM Evolution Towards 3rd Generation Systems*, chapter In-door Base Station Systems : Improving GSM to meet low-tier challenge, pages 235–261. Springer US, 2002.
- [63] K. Stamatiou and J.G. Proakis. A performance analysis of coded frequency-hopped ofdma [cellular system]. In *Wireless Communications and Networking Conference, 2005 IEEE*, volume 2, pages 1132 – 1137 Vol. 2, 13-17 2005.
- [64] Y. C. Tay and K. C. Chua. A capacity analysis for the ieee 802.11 mac protocol. *Wirel. Netw.*, 7(2):159–171, 2001.
- [65] Fouad A. Tobagi. Distributions of packet delay and interdeparture time in slotted aloha and carrier sense multiple access. *J. ACM*, 29(4):907–927, 1982.
- [66] Alvaro Valcarce, David Lopez-Perez, Guillaume De La Roche, and Jie Zhang. Limited access to ofdma femtocells. In *Proc. of IEEE Personal, Indoor and Mobile Radio Communications Symposium (PIMRC)*, 2009.
- [67] Haifeng Wang and J. Lilleberg. Conventional and scrambling ofdm system switch in multicell environments. In *Wireless Communications and Networking Conference, 2006. WCNC 2006. IEEE*, volume 1, pages 1 –5, 3-6 2006.
- [68] Li-Chun Wang, G.L. Stuber, and Chin-Tau Lea. Architecture design, frequency planning, and performance analysis for a microcell/macrocell



- overlying system. *Vehicular Technology, IEEE Transactions on*, 46(4):836–848, nov 1997.
- [69] J. Weitzen and T. Grosch. Comparing coverage quality for femtocell and macrocell broadband data services. *Communications Magazine, IEEE*, 48(1):40–44, jan. 2010.
- [70] Krzysztof Wesolowski. *Introduction to Digital Communication Systems*. Wiley, 2009.
- [71] P.D. White, M.K. Gurcan, and R.J.G. MacNamee. 900 mhz digital cordless telephone. In *IEE Proceedings-F: Communications, Radar and signal proceedings*, volume 132, pages 425–432. Philips, Research Laboratories, Redhill, UK, August 1985.
- [72] J Yin, X Wang, and D P Agrawal. Optimal packet size in error-prone channel for ieee 802.11 distributed coordination function. In *Proc. IEEE WCNC'04*, pages 1654–1659, Atlanta, USA, March 2004.
- [73] J Yin, X Wang, and D P Agrawal. Modeling and optimization of wireless local area network. *Computer Communications*, 28(10):1204–1213, June 2005.
- [74] J. Zhang and G. de la Roche. *Femtocells Technologies and Deployment*. Wiley, 2010.
- [75] Eustathia Ziouva and Theodore Antonakopoulos. CSMA/CA performance under high traffic conditions: throughput and delay analysis. *Computer Communications*, 25(3):313–321, 2002.

# Publications

Y. Haddad, D. Porrat. **Femtocell SINR Performance Evaluation**. In Proc. of International Conferences on Access Networks, Services and Technologies. IARIA ACCESS 2010. Valencia Spain, September 2010.

Y. Haddad, D. Porrat. **A Two-Tier Frequency Reuse Scheme** in Proc. Of Second International Workshop on Indoor and Outdoor Femto cells (IOFC'10) in conjunction with IEEE PIMRC'10, Turkey, September 2010.

Y. Haddad, D. Porrat. **Femtocell: Opportunities and Challenges of the Home Cellular Base Station for the 3G** . In Proc. of IADIS International Multi Conference on Computer Science and Information Systems (session on Wireless Applications and Computing), Algarve, Portugal, June 2009.

Y. Haddad, G. Le Grand. **Throughput analysis of the IEEE 802.11e EDCA on a noisy channel in unsaturated mode** in Proc. of the 3rd ACM International Workshop on Wireless Multimedia Networking and Performance Modeling (WMuNeP) October 2007.

Y. Haddad, G. Le Grand. **Performance Analysis of IEEE 802.11e EDCA under Finite Load in an Error Prone Channel**. In Proc. of JDIR'2007, France, January 2007.